



## IMPORTANT

Keep in store for future reference!

# FREEDOM LINE

## Installation & Operation Manual

Shipped With Case Data Sheets

P/N 3001933\_M  
November 2023  
Spanish P/N 3001934



## BEFORE YOU BEGIN

Read these instructions completely and carefully.



This manual was written in accordance with originally prescribed equipment that is subject to change. Hussmann reserves the right to change or revise specifications and product design in connection with any feature of our products.

## PERSONAL PROTECTION EQUIPMENT (PPE)



Only qualified personnel should install and service this equipment. Personal Protection Equipment (PPE) is required whenever servicing this equipment.

Wear safety glasses, gloves, protective boots or shoes, long pants, and a long-sleeve shirt when working with this equipment and handling glass. Observe all precautions on tags, stickers, labels and literature attached to this equipment.

## FREEDOM LINE MERCHANDISERS

Freedom Line models are designed to be ready for remote installation of a top-mounted, air-cooled, or water-cooled condensing unit, such as Hussmann's Freedom Line condensing units. The unit has an electronic controller. The case temperature is controlled by cycling the compressor based on the discharge air temperature input. The sensor for this input is located in the discharge air stream above the interior top panel. Defrost is time initiated and terminated. The controller is pre-programmed for medium temperature food operation. Freedom cases running on individual condensing units may be installed as stand-alone cases with ends, or as part of a lineup. When installed in a lineup, Hussmann recommends that partitions be installed between individual cases to prevent frost buildup and other issues that might result from different defrost schedules and operating temperatures.



This warning does not mean that Hussmann products will cause cancer or reproductive harm, or is in violation of any product-safety standards or requirements. As clarified by the California State government, Proposition 65 can be considered more of a 'right to know' law than a pure product safety law. When used as designed, Hussmann believes that our products are not harmful. We provide the Proposition 65 warning to stay in compliance with California State law. It is your responsibility to provide accurate Proposition 65 warning labels to your customers when necessary. For more information on Proposition 65, please visit the California State government website.

## TABLE OF CONTENTS

<b>INSTALLATION TOOL LIST</b> .....	iv	<b>DRIP PIPING / FACADES / SPLASHGUARDS /</b>	
<b>ANSI Z535.5 DEFINITIONS</b> .....	iv	<b>BUMPERS</b>	
<b>INSTALLATION</b>		Waste Outlet and Water Seal .....	3-1
UL Listing .....	1-1	Installing Drip Piping .....	3-2
Federal & State Regulation .....	1-1	Optional Hub Drain Drip Piping Example	
Location .....	1-1	for Ultra Low Front Cases .....	3-4
Product Temperature .....	1-1	Installing Facade .....	3-7
Shipping Damage .....	1-2	Final Alignment / Fit & Finish .....	3-9
Apparent Loss or Damage .....	1-2	Installing Splashguard Brackets .....	3-12
Concealed Loss or Damage .....	1-2	Installing Splashguards (Retainers and Panels) .....	3-13
Unloading .....	1-2	Splashguard Alignment to Eliminate Gaps in	
Exterior Loading .....	1-2	Cases Line-Up .....	3-14
Unloading with Pallet Jack .....	1-3	<b>START UP / OPERATION</b>	
Optional Casters and Dollies .....	1-3	Expansion Valve Adjustment .....	4-2
Serial Plate Location .....	1-3	Start up .....	4-3
QR Code .....	1-3	Stocking .....	4-3
Merchandisers Shipped with End Installed .....	1-4	Load Limits .....	4-3
End Shipping Braces .....	1-4	Shelf Maximum Weight Limits .....	4-4
Shipping Rider .....	1-4	Multi-deck Shelf Configuration .....	4-4
Merchandiser Leveling .....	1-5	LED Fixtures .....	4-5
Joining Cases in a Lineup .....	1-6	Procedure For Installing Lighted Shelves .....	4-6
Apply Gaskets .....	1-7	Installing FDA/NSF Required Thermometer .....	4-9
Joining Detail Views .....	1-8	<b>MAINTENANCE</b>	
Joining Door Cases .....	1-12	Care and Cleaning .....	5-1
Adjusting EcoVision Doors .....	1-14	Fan Plenum .....	5-1
Adjusting Door Closing Speed .....	1-15	Removable Return Air Grilles .....	5-1
Replacing LED Vertical Mullion Light Bars .....	1-15	Fascia Panels .....	5-2
Installing End Assemblies .....	1-17	Exterior Surfaces .....	5-2
Partitions Hardware .....	1-20	Interior Surfaces .....	5-2
Acrylic Partitions Hardware .....	1-25	Do not Use .....	5-2
Installing Bumpers .....	1-28	Steps .....	5-2
Installing Night Curtains .....	1-29	Recommended Cleaning Instructions .....	5-3
Loading Blind Spring .....	1-31	Cleaning Honeycomb Assemblies .....	5-4
Troubleshooting Night Blinds .....	1-32	Cleaning Mirrors .....	5-5
<b>REFRIGERATION / ELECTRICAL / CONTROLLER</b>		Removing Interior Back Panels .....	5-5
Refrigerant .....	2-1	Bottom Liner Repair .....	5-6
Field Installation of Condensing Unit .....	2-1	Cleaning Coils .....	5-7
Field-Installed Condensing Unit Location		Cleaning Stainless Steel Front Rails .....	5-7
(Air-cooled option) .....	2-2	Removing Scratches from Bumper .....	5-7
Field-Installed Condensing Unit Location		Cleaning Under Merchandisers .....	5-7
(Water cooled option) .....	2-3	Cleaning Condensate Pump and Heated	
About Quick Connect Couplings .....	2-4	Evaporation Pans .....	5-8
Connect Lines .....	2-4	<b>SERVICE</b>	
Correctly Tightened Coupling .....	2-6	Replacing Fan Motors .....	6-1
Insulate Refrigerant Lines .....	2-6	Doors (Installing, Removing, Adjusting) .....	6-3
Field Wiring .....	2-7	Adjusting EcoVision Doors .....	6-3
Controller Display .....	2-7	Adjusting Door Closing Speed .....	6-4
Optional Condensate Water Pan and Pump .....	2-9	Replacing LED Canopy Light Bars .....	6-5
Electrical Connections .....	2-12	Replacing LED Shelf Light Bars .....	6-5
Identification of Wiring .....	2-12	Replacing LED Vertical Mullion Light Bars .....	6-6
Installation of Water Lines .....	2-13	Replacing LED Power Supplies .....	6-6
Pre-Installation System Cleaning .....	2-14	Replacing Door Handles .....	6-7
Electronic Controller .....	2-15	Repairing Aluminum Coil .....	6-10
Controller .....	2-17	Warranty Information .....	6-11
		<b>APPENDIX</b>	
		Replacing Fan Motors (locking harness connector) .....	7-1

## ANSI Z535.5 DEFINITIONS

The definitions below are used to clarify the magnitude and urgency of harm and damage, considering problems arising from misuse. Relative to their potential danger, the definitions are divided into four parts according to ANSI Z535 Series.



**DANGER** indicates a hazardous situation which, if not avoided, will result in death or serious injury.



**WARNING** indicates a hazardous situation which, if not avoided, could result in death or serious injury.



**CAUTION** indicates a hazardous situation which, if not avoided, could result in minor or moderate injury.



**NOTICE** is used to address practices not related to personal injury.



**SAFETY INSTRUCTIONS** (or equivalent) signs indicate specific safety-related instructions or procedures.

## INSIGHT INSTALLATION

## TOOL LIST

(Recommended)



Unloading From Trailer:

Lever Bar (also known as a Mule,  
Johnson Bar, J-bar, Lever Dolly, and pry  
lever)

Moving Dolly



Setting Case Line-Up:

Level, 4 ft (suggested)

Ratchet

1/4 in. Socket Drill Bit

5/16 in. Socket Drill Bit

1/2 in. Socket - Deep Drill Bit

1/2 in. Open End Wrench

Cordless Impact Drill

Caulking Gun

10 in. Adjustable Crescent Wrench

Pallet Jack

## MANUAL REVISION HISTORY

**REVISION M** - Updated fan motor instructions;  
created Appendix

**REVISION L**

1. Removed Page 5-4; Revised fan motor service  
instructions, Page 6-1, 6-2. Updated cleaning procedures,  
Page 5-1. Updated warning colors

**REVISION K**

1. Revised procedures for fan motor harness connector,  
Section 5 & 6.

# INSTALLATION

## UL LISTING

These merchandisers are manufactured to meet ANSI/ UL 471 standard requirements for safety. Proper installation is required to maintain the listing.

## FEDERAL / STATE REGULATION

These merchandisers at the time they are manufactured, meet all federal and state/ provincial regulations. Proper installation is required to ensure these standards are maintained. Near the serial plate, each merchandiser carries a label identifying the environment for which the merchandiser was designed for use.

**ANSI/NSF-7 Type I – Display Refrigerator / Freezer  
Intended for 75°F (24°C) / 55% RH Ambient Application**

**ANSI/NSF-7 Type II – Display Refrigerator / Freezer  
Intended for 80°F / 55% RH Ambient Application**

**ANSI/NSF-7 – Display Refrigerator  
Intended for Bulk Produce**

## LOCATION

These merchandisers are designed for displaying products in air conditioned stores where temperature is maintained at or below the ANSI/ NSF-7 specified level and relative humidity is maintained at or below 55%.

Placing refrigerated merchandisers in direct sunlight, near hot tables or near other heat sources could impair their efficiency. Like other merchandisers, these are sensitive to air disturbances. Air currents passing around merchandisers will seriously impair their operation. Do NOT allow air conditioning, electric fans, open doors or windows, etc. to create air currents around the merchandisers.

## PRODUCT TEMPERATURE

Product should always be maintained at proper temperature. This means that from the time the product is received, through storage, preparation and display, the temperature of the product must be controlled to maximize product life.

ATTENTION

Merchandiser must operate for 24 hours before loading product!

Regularly check merchandiser temperatures. Do not break the cold chain. Keep products in cooler or freezer before loading into merchandiser.

Medium temperature merchandisers are designed for loading ONLY pre-chilled products.

Low temperature merchandisers are designed for loading ONLY frozen products.



A 1.5 inch (38 mm) space between the rear of the merchandiser and wall must be maintained for air circulation. However, in high ambient conditions, sweating may still occur. If this happens install a method of forced ventilation such as a fan ventilation kit.

## ⚠ WARNING

- » Use caution when working around refrigeration lines or water lines. Damage to equipment and/or personal injury could occur.

## 1-2 INSTALLATION

### SHIPPING DAMAGE

All equipment should be thoroughly examined for shipping damage before and during unloading.

This equipment has been carefully inspected at our factory. Any claim for loss or damage must be made to the carrier. The carrier will provide any necessary inspection reports and/or claim forms.

#### Apparent Loss or Damage

If there is an obvious loss or damage, it must be noted on the freight bill or express receipt and signed by the carrier's agent; otherwise, carrier may refuse claim.

#### Concealed Loss or Damage

When loss or damage is not apparent until after equipment is uncrated, retain all packing materials and submit a written request to the carrier for inspection, within 15 days.

### UNLOADING

Improper handling may cause damage to the merchandiser when unloading. Use the shipping brace and arched pod locations to lift when unloading cases.

1. Do not drag the merchandiser out of the trailer. Use a Johnson bar (mule).
2. Do not lift the case by the liner. Lift with the metal case base, arched plastic pods or the shipping brace.
3. Do not lift from the bottom edge of the end panel.

### EXTERIOR LOADING

**Do NOT walk on top or inside of merchandisers** or damage to the merchandisers and serious personal injury could occur. **THEY ARE NOT STRUCTURALLY DESIGNED TO SUPPORT EXCESSIVE EXTERNAL LOADING** such as the weight of a person.

Use caution when working around refrigeration lines or water lines, damage to equipment and personal injury could occur.

### ⚠ WARNING

- » If the case is to be moved using a fork lift, position the forks of the lift directly under the arched pods or shipping rails. Use extreme caution when transporting cases. Personal injury or death could result if a case falls on personnel.

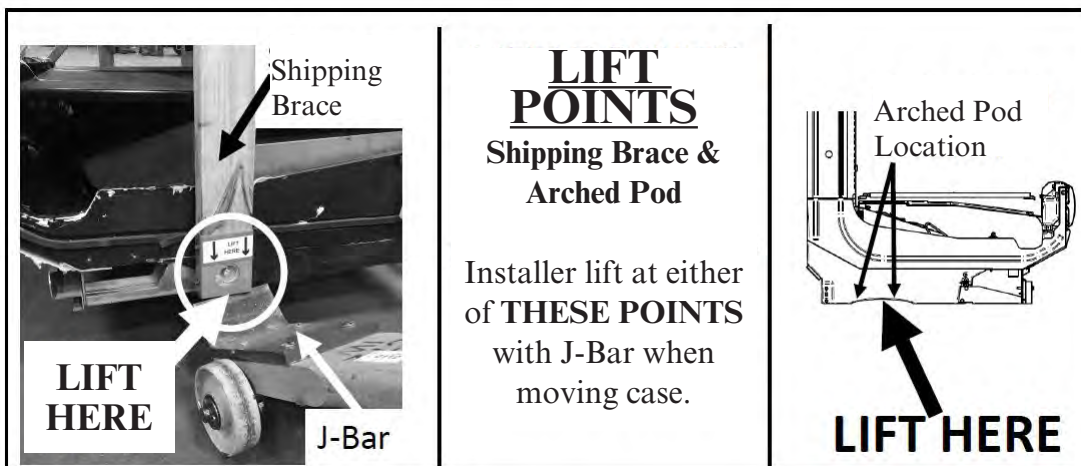

### UNLOADING USING A PALLET JACK

A pallet jack is also very helpful in moving a merchandiser to its permanent location. It can also be used to remove optional casters or to shim the case.



### OPTIONAL CASTERS AND DOLLIES

Cases may be equipped with factory installed casters or dollies. Instructions for removing the casters or dollies are included in a separate document, shipped with the case. Use caution when transporting cases from the truck to the store location.

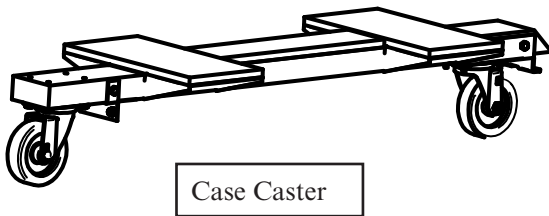

**⚠ WARNING**

» Use caution when moving cases with casters or dollies. Damage to equipment and personal injury could occur from improper handling.

### SERIAL PLATE LOCATION

Serial plates are located on the left side, facing the case. The serial plate contains information about the specific model and its operating parameters.

**NOTE:** A second serial plate for multi-deck cases is also located behind the return air grille in the same location as single-deck cases (shown below).

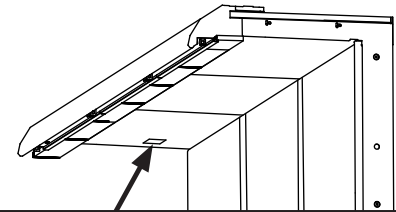

Serial Plate inside Canopy (multi-deck)

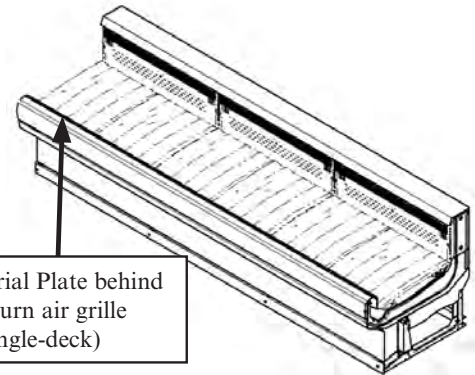

Serial Plate behind return air grille (single-deck)

### QR CODE

Insight cases have a QR code located on the serial plate. Once you scan the QR code with a smart phone, all of the information about that case will be at your fingertips. Links to installation videos, data sheets with case specifications, the installation and operation manual, as well as a link to replacement parts from Hussmann's Performance Parts Website.



## 1-4 INSTALLATION

### MERCHANDISERS SHIPPED WITH END INSTALLED

If the merchandiser was shipped with the end installed, two long bolts were used to hold the shipping brace to the end. If the shipping bolts are reinserted after removing the brace, they will extend into the product area. **THEREFORE, BE SURE TO REPLACE THESE BOLTS WITH THE SHORTER BOLTS PROVIDED.** NSF requires any bolt or screw in the product area be capped or cut off if it has more than three exposed threads.



Be careful not to damage the factory installed end while moving the merchandiser.

### CAUTION

» Do not remove shipping braces until the merchandisers are positioned for installation.

### END SHIPPING BRACES

Move the merchandiser as close as possible to its permanent location, then remove all packaging. Check for damage before discarding packaging. Remove all separately packed accessories such as kits and shelves.

**Do not remove end braces until joining begins.**  
Recycle wooden braces and hardware.

### SHIPPING RIDER

Some merchandisers are shipped on a rider to protect the factory installed front legs, and to make positioning the merchandiser easier. To remove the rider, remove bolts attaching rider to each leg.

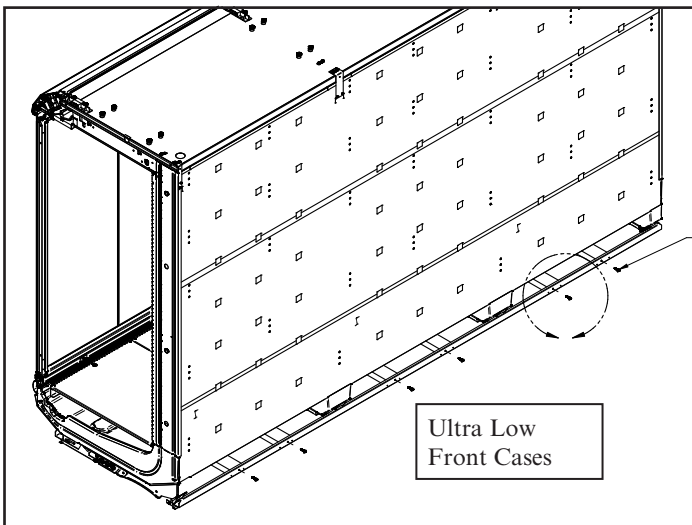
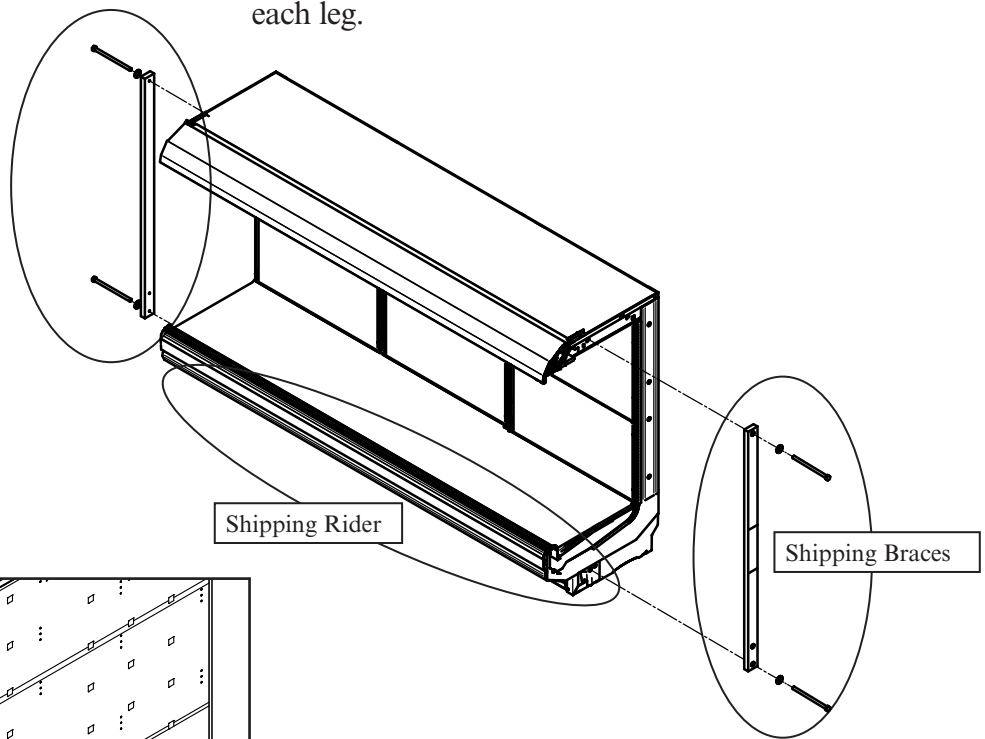

Remove 6 Screws and Wooden Supports Prior to Moving Case into Position (rear rail will remain attached to merchandiser)

Ultra Low Front Cases

## MERCHANDISER LEVELING

### IMPORTANT

Merchandisers must be installed level to ensure proper operation of the refrigeration system and to ensure proper drainage of defrost water. Pay close attention to case position during all steps of setting, joining and leveling.

**NOTE:** BEGIN LINEUP LEVELING FROM THE HIGHEST POINT OF THE STORE FLOOR.

### Preparation

1. Using store blueprints, measure off and mark on floor the exact dimensions/locations of the merchandiser footprint. **A 1½ inch space is required behind each merchandiser to prevent condensation.**
2. Snap a chalk line for the front and rear positions of the base pods.
3. Mark the location of each joint from front to back lines.
4. **USE SUPPLIED SHIMS TO LEVEL CASE. Shims are to be inserted under the black, plastic base pods.**

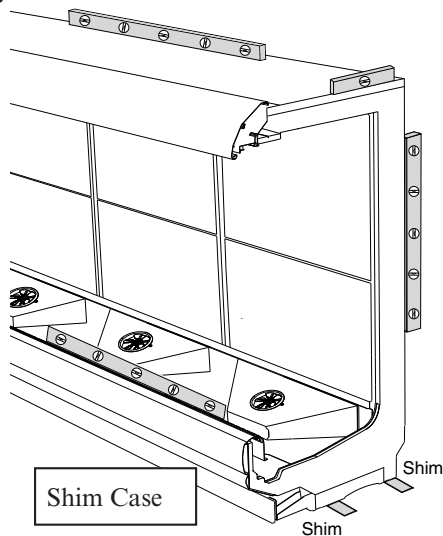

### CAUTION

- » Tipping Hazard! Case tipping may occur if cases are not properly leveled and secured, or if cases are not properly loaded.



### Case Lineup Leveling

1. **FLOORS ARE NOT LEVEL!** The whole lineup must be leveled on the same plane, left to right and front to back. This means that the entire lineup must be brought up to the level of the highest case in the lineup.

Along the lines previously marked, find the highest point of the floor by:

- Walking the floor and noticing any dips or mounds;
- Using a string level; and
- Using a transit.



















2. Position the first merchandiser at the highest point on the floor. Work outward from that point to create the merchandiser lineup.

3. Use a 48 inch (1220 mm) or longer level for end-to-end leveling. The rear edge of the top foam panel of the merchandiser is a good location for the level at the rear of the case.

4. For leveling the merchandiser front-to-rear, a 24 inch (610 mm) level should be placed on the lower flange of the merchandiser end frame. If the merchandiser has a factory installed end, the level should be placed on the canopy support brackets on top of the merchandiser. Suggested level locations are shown in the illustration.

JOINING CASES IN A LINEUP  
JOINING AND SEALING HARDWARE

Description	Multi Deck Qty/Each	Convertible Qty/Each	Single Deck Qty/Each	Door Multi Deck Qty/Each
SEALER SILICONE ADHESIVE	1	1	1	1
GASKET 1/2 X 1/2 X 180	2	1	1	2
SCREW-SHEET METAL #8 X 5/8 PHIL HX HD	N/A	1	N/A	N/A
SCREW-CAP 1/4 x 3/4 HEX	N/A	N/A	N/A	2
BOLT HEX CAP 5/16 x 3/4	1	1	1	1
BOLT 5/16 x 2 3/4 GRADE 5 ZINC PLATED TAP	2	N/A	N/A	2
BOLT- TAP, 5/16 x 4 1/2, STEEL, ZINC FINISH, GR5 (Qty Varies)	5	2	1	5
BOLT- TAP, 5/16 x 7, STEEL, ZINC FINISH, GR5	1	1	1	1
WASHER-FLAT 5/16" ZINC (Qty Varies)	13	5	3	13
LOCKWSHR 1/4 SPLT STL	N/A	N/A	N/A	2
LOCKWSHR 5/16 SPLT STL	1	1	1	1
NUT-HEX 1/4	N/A	N/A	N/A	2
NUT-HEX 5/16 STEEL ZINC FINISH GRADE 8 (Qty Varies)	9	4	3	9
NUT-HEX 3/8-24 SERRATED FLANGE	4	N/A	N/A	4
PIN-ALIGNMENT	1	1	1	N/A
CONE-CASE ALIGNMENT (Qty Varies)	4	2	2	4
PLATE-BOTT DOOR RAIL ALIGNMENT	N/A	N/A	N/A	1
BRACKET-CASE JOINING	4	N/A	N/A	4
BRACKET-FASCIA ALIGNMENT IC2 & IC3	N/A	1	N/A	N/A
COVER-HAND RAIL JOINT	1	1	1	N/A
TAPE-BUTYL 1/16 x 2" X 49"	1	1	1	1

- Screw-Sheet Metal #8 x 5/8 ● 
- Screw-Cap 1/4 x 3/4 ⊙ 
- Bolt-5/16 x 3/4 ⊗ 
- Bolt-5/16 x 2 3/4 ⊗ 
- Bolt-5/16 x 4 1/2 ⊗ 
- Bolt-5/16 x 7 ⊗ 
- Washer Flat-5/16 ⊙ | 
- Washer Lock-1/4 ⊙ 
- Washer Lock-5/16 ⊙ 
- Nut Hex-1/4 ⊗ 
- Nut Hex-5/16 ⊗ 
- Nut Hex-3/8 Serr Flange ⊗ 
- Pin-Alignment 
- Cone-Alignment 
- Plate-Bottom Door Rail Alignment 
- Bracket-Case Joining 
- Bracket-Fascia Alignment IC2 & IC3 
- Cover-Handrail Joint 

**IMPORTANT:**

Do not pull cases together with bolts. Cases must be moved together as close as possible. Follow sequence balloons to tighten bolts.

Apply gasket to only one side of case joint.

Remove end shipping braces as described on Page 1-4.

Cases must be leveled as described on Page 1-5.

Removed any casters - if installed.

Install case lineup from left to right.

Remove shelves, display racks, pans & interior back panels at the joining area.

Insert gasket into case channels the entire length with no gaps.

Do not stretch gasket, especially around corners.

Do not butt gaskets, always overlap them.

Remove paper backing after gasket has been applied.

Perimeter gasket is required by NSF.

Apply a continuous bead of neutral curing silicone sealant.

Joints must be air tight to prevent formation of ice of condensation.

**APPLY GASKETS  
(MULTI-DECK)**

IP4 / IM5 / ID5 / ID6 / IC6 / IC4  
Case bolting details begin on the next page.

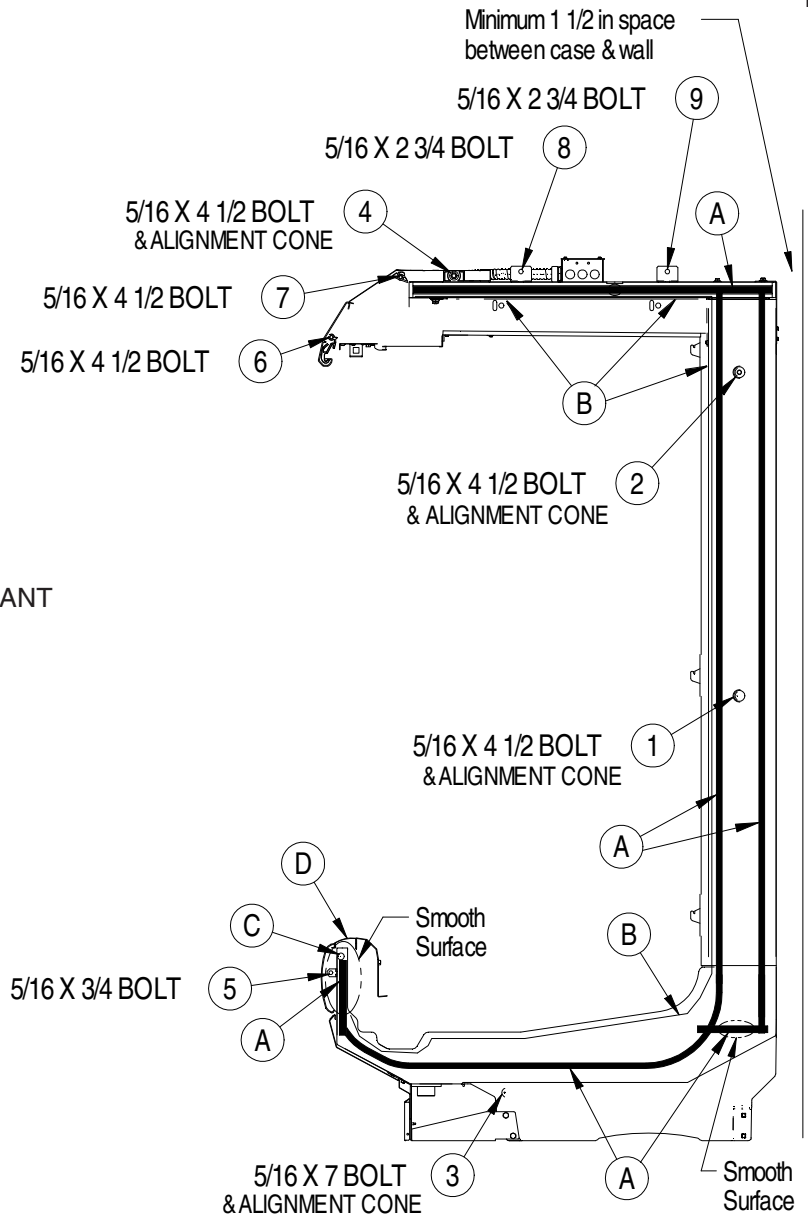

**LEGEND:**

- A = 1/2 x 1/2 INCH GASKET
- B = NEUTRAL CURING SILICONE SEALANT
- C = PIN-ALIGNMENT
- D = COVER-HAND RAIL JOINT

**IMPORTANT:**

Do not pull cases together with bolts. Cases must be moved together as close as possible. Follow sequence balloons to tighten bolts.

Merchandiser case joint & end gasket to be applied on only one side of joint.

Merchandiser partition gasket to be applied on both sides of joint.

Remove end shipping braces as described on Page 1-4

Cases must be leveled as described on Page 1-5

Removed any casters - if installed

Install case lineup from left to right

Remove shelves, display racks, pans & interior back panels at the joining area

Insert gasket into case channels the entire length with no gaps

Do not stretch gasket, especially around corners

Do not butt gaskets, always overlap them

Remove paper backing after gasket has been applied

Perimeter gasket is required by NSF

Apply a continuous bead of neutral curing silicone sealant

Joints must be air tight to prevent formation of ice or condensation.

# 1-8 INSTALLATION

## CASE JOINING (MULTI-DECK / REAR LOAD) IP4 / IM5 / ID5 / ID6 / IC6 / IC4

Refer to detail views

### LEGEND:

C = PIN-ALIGNMENT

Do not pull cases together with bolts. Cases must be moved together as close as possible. Follow sequence balloons 1, 2, 3 to tighten bolts.

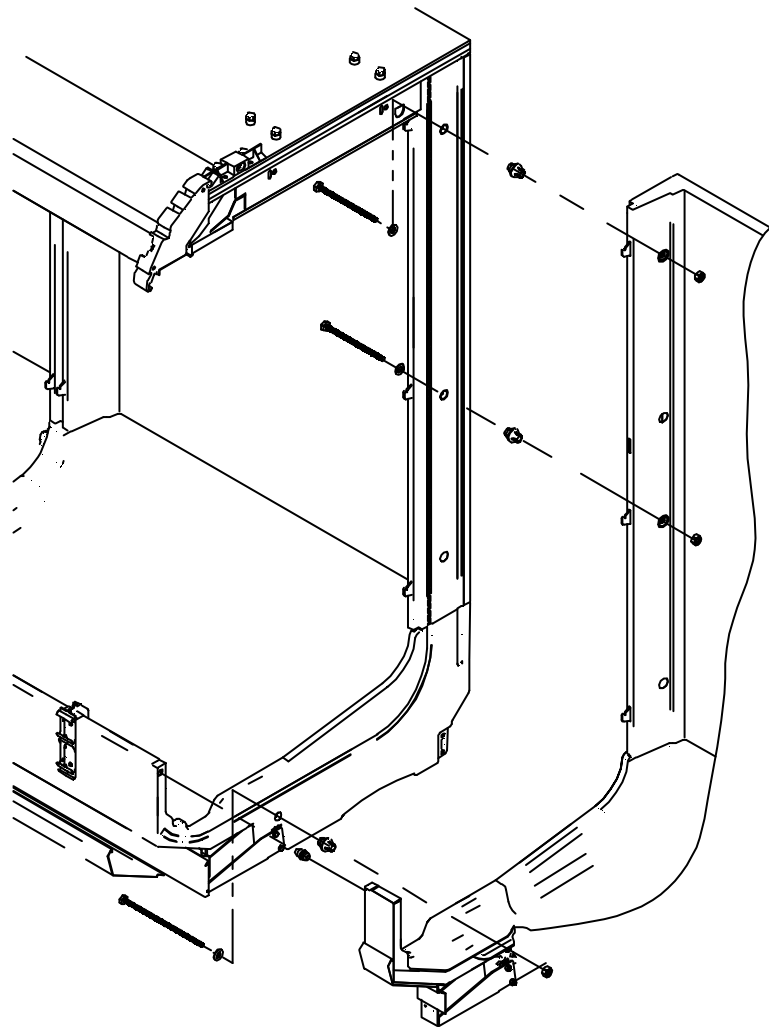
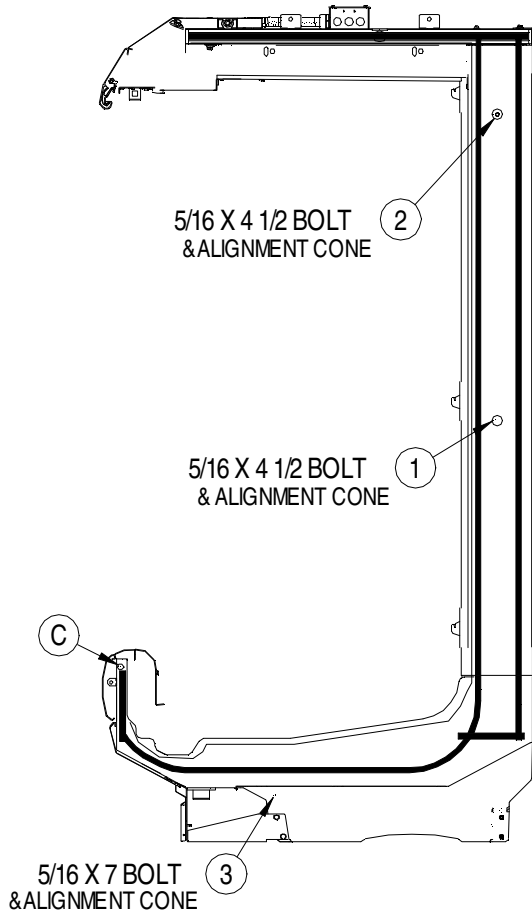

**CASE JOINING (MULTI-DECK / REAR LOAD)**

IP4 / IM5 / ID5 / ID6 / IC6 / IC4

Refer to detail views

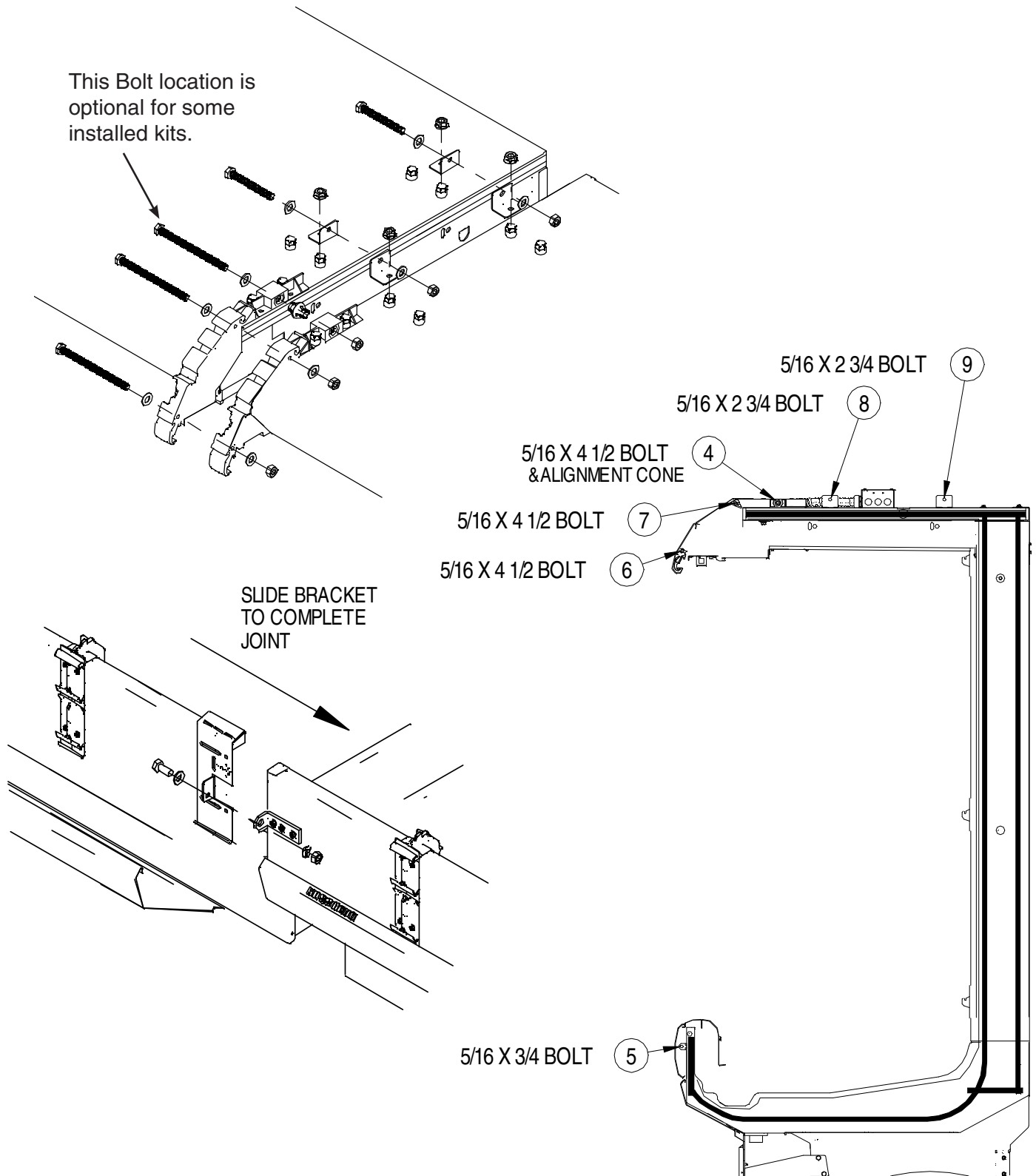

**1-10      INSTALLATION**

**CASE JOINING (MULTI-DECK / REAR LOAD)**

**IP4 / IM5 / ID5 / ID6 / IC6 / IC4**

Refer to detail views

**LEGEND:**

D = COVER-HAND RAIL JOINT

Push Cover  
in this direction  
to snap fit

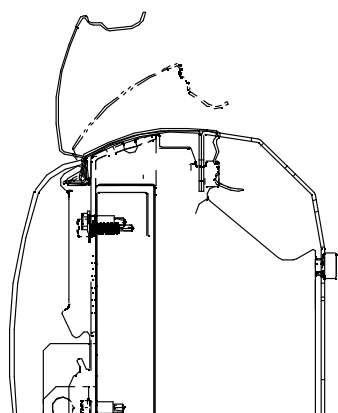

Cover-Hand Rail Joint

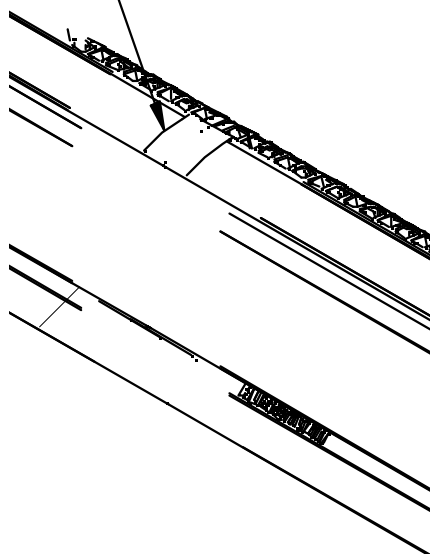

D

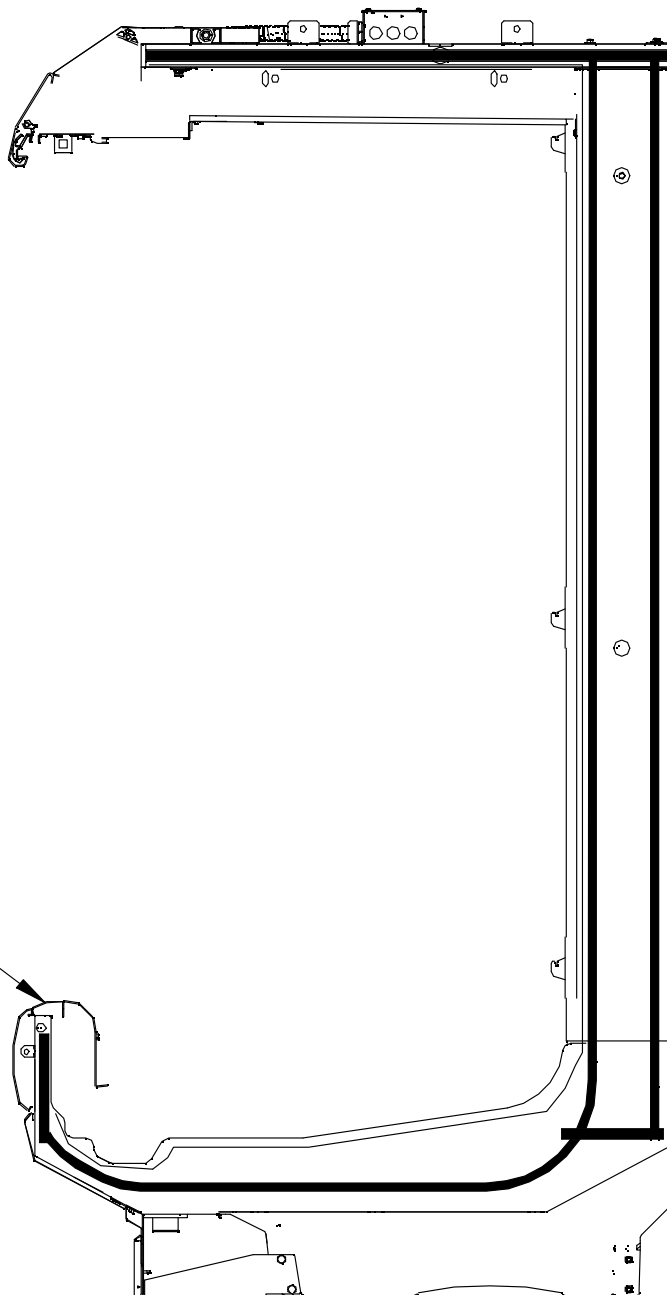

**APPLY GASKETS  
(DOOR CASES)**

Case bolting details begin on the next page.  
Refer to Page 1-6 for hardware list.

Do not pull cases together with bolts.  
Cases must be moved together as close  
as possible. Follow sequence balloons  
to tighten bolts.

**LEGEND:**

- A = 1/2 x 1/2 INCH GASKET
- B = NEUTRAL CURING SILICONE SEALANT
- C = PIN-ALIGNMENT
- F = PLATE BOTTOM DOOR RAIL ALIGNMENT

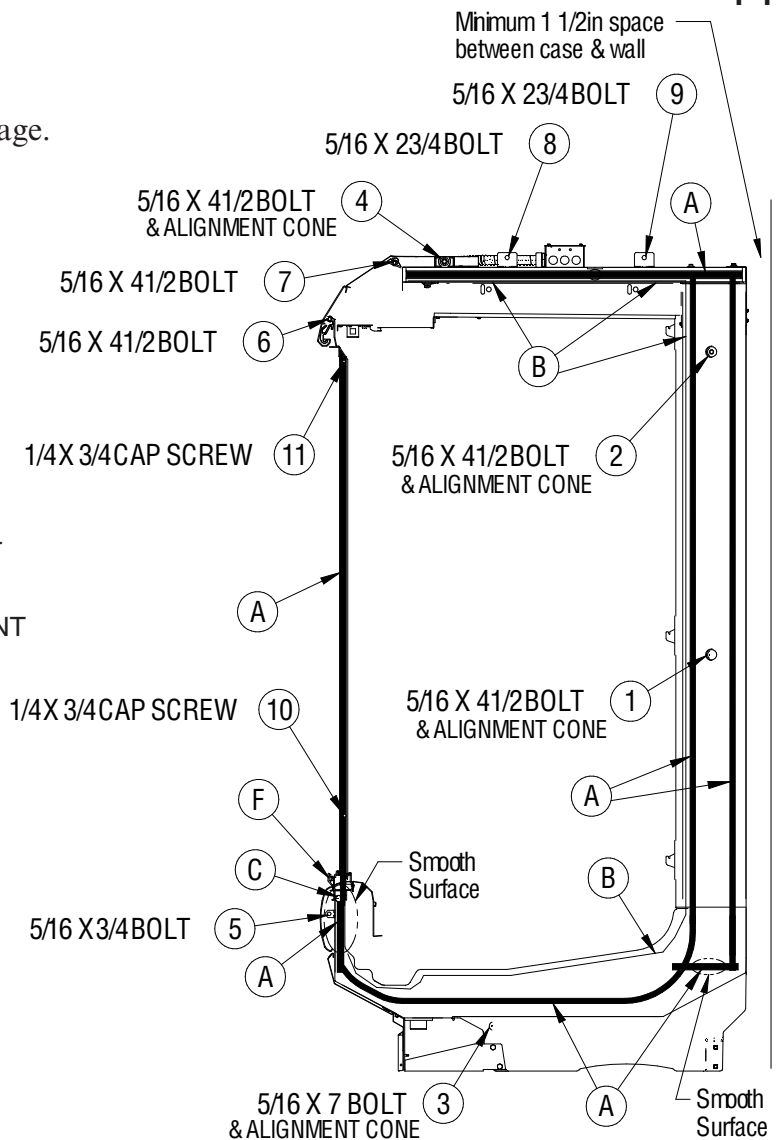

**IMPORTANT:**

Do not pull cases together with bolts. Cases must be moved together as close as possible. Follow sequence balloons to tighten bolts.

Merchandise case joint & end gasket to be applied on only one side of joint.

Merchandise partition gasket to be applied on both sides of joint.

Remove end shipping braces as described on Page 1-4

Cases must be leveled as described on Page 1-5

Remove any casters - if installed

Install case lineup from left to right

Remove shelves, display racks, pans & interior back panels at the joining area

Insert gasket into case channels the entire length with no gaps

Do not stretch gasket, especially around corners

Do not butt gaskets, always overlap them

Remove paper backing after gasket has been applied

Perimeter gasket is required by NSF

Apply a continuous bead of neutral curing silicone sealant

Joints must be air tight to prevent formation of ice or condensation.

**CASE JOINING  
(DOOR & REAR LOAD CASES)  
CONTINUED**

**LEGEND:**

C=PIN-ALIGNMENT

F=PLATE-BOTT DOOR RAIL ALIGNMENT

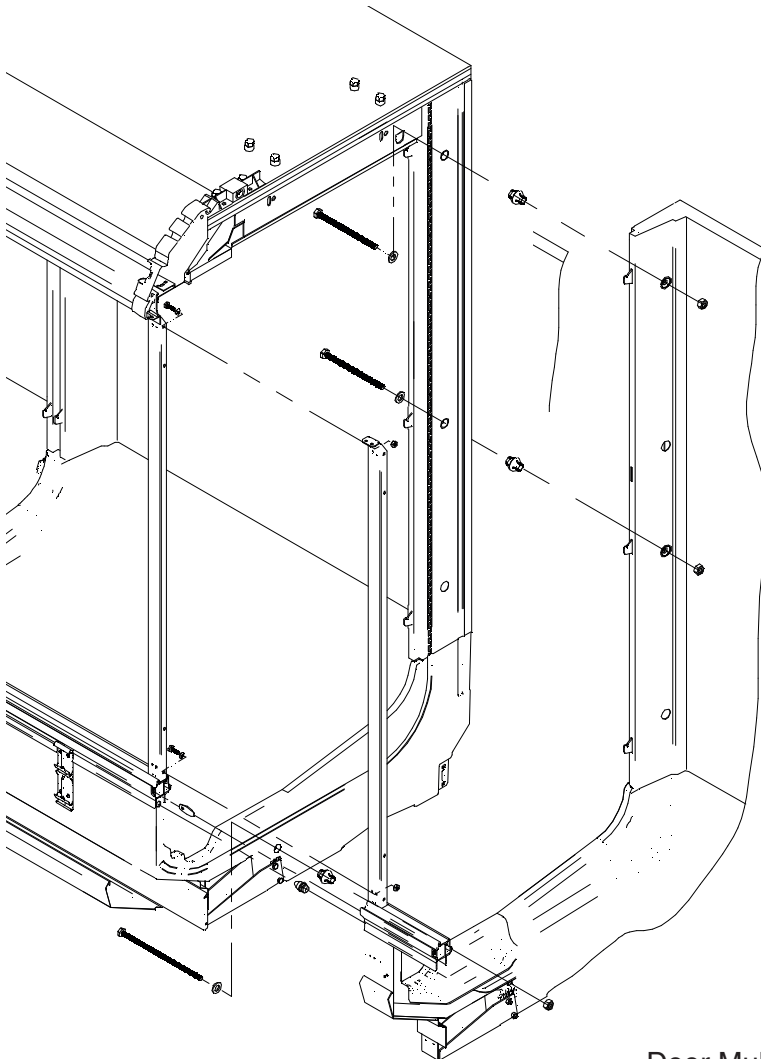

1/4 X 3/4 CAP SCREW (11)

5/16 X 4 1/2 BOLT & ALIGNMENT CONE (2)

5/16 X 4 1/2 BOLT & ALIGNMENT CONE (1)

1/4 X 3/4 CAP SCREW (10)

(F)

(C)

5/16 X 7 BOLT & ALIGNMENT CONE (3)

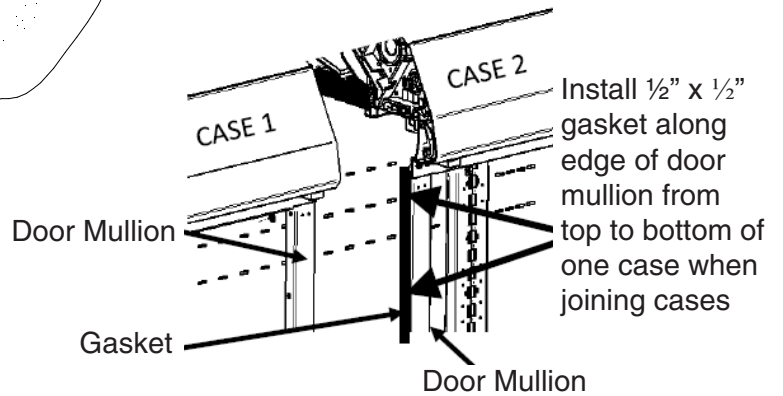

CASE 1

CASE 2

Door Mullion

Gasket

Door Mullion

Install 1/2" x 1/2" gasket along edge of door mullion from top to bottom of one case when joining cases

Door Gasket Installation

### CASE JOINING (DOOR & REAR LOAD CASES)

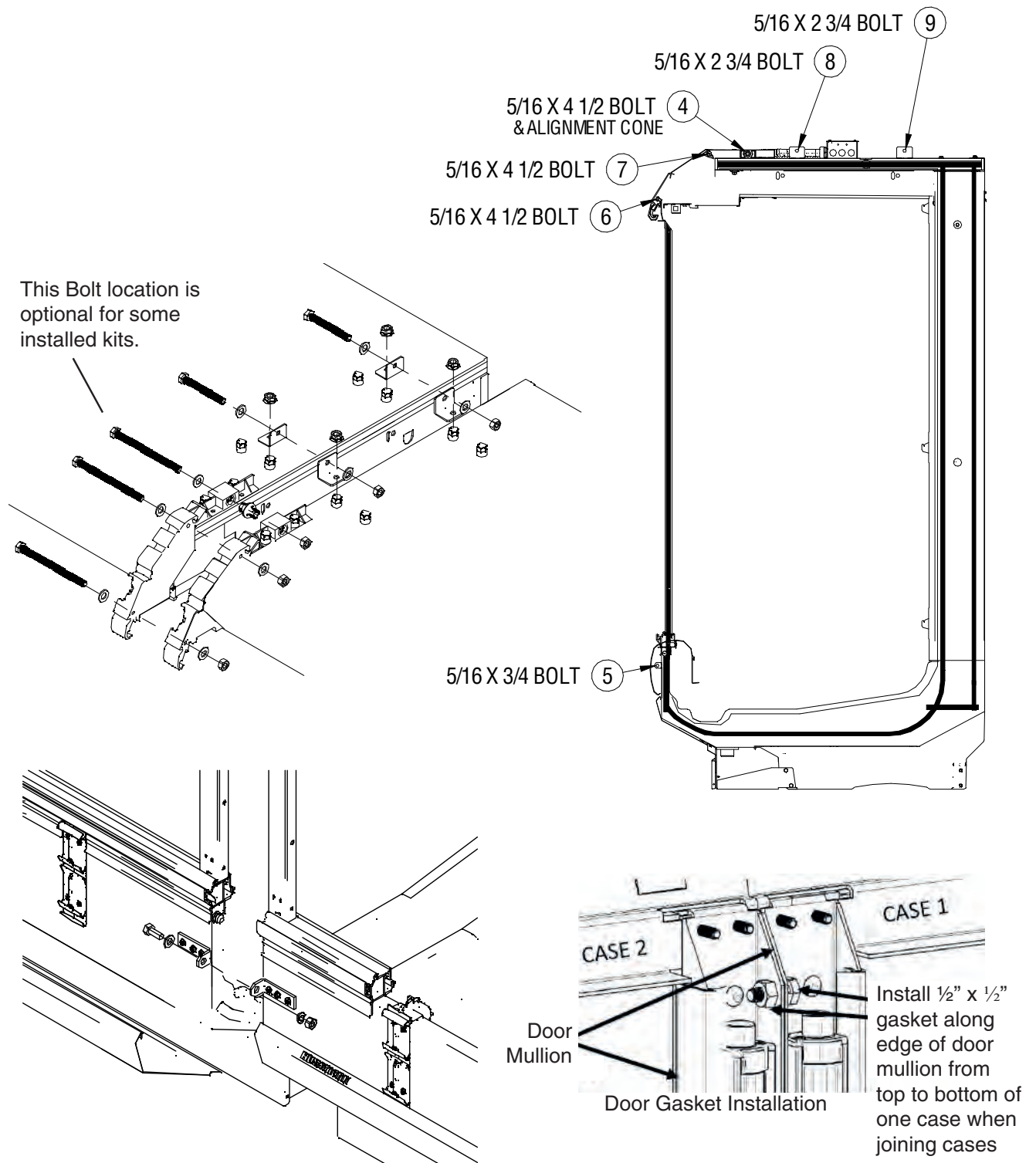

**ADJUSTING ECOVISION DOORS**

Check that all doors open and close properly.

Excessive ambient conditions may cause condensation and therefore sweating of doors. Facility operators should monitor doors and floor conditions to ensure safety of persons.

**A. Leveling** — Merchandisers must be installed level to ensure proper operation of the refrigeration system, and to ensure proper drainage of defrost water.

**B. Door Adjustment** — Loosen the screws A, B and C as shown below (Do not remove the screws completely).

Glass alignment is also affected with improper leveling of the merchandisers. All steps of setting joining and case leveling attention to the glass position is critical. Do not attempt to make glass adjustments prior to case leveling.

Slide the bottom plate left and right until proper alignment is achieved. Retighten the screws A, B and C. Install fasteners in locations 1 and 2 as shown below.

EcoVision Door Alignment - Modular Bottom Hinge Plate

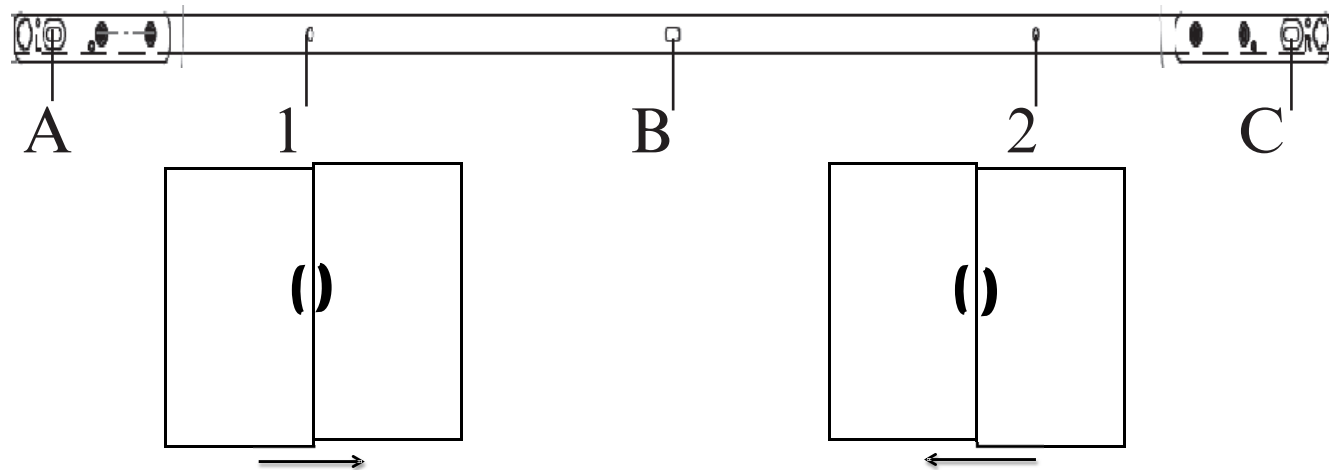

To Correct Shift the Bottom Plate to the Right

To Correct Shift the Bottom Plate to the Left

## ADJUSTING DOOR CLOSING SPEED

The door's closing speed is factory adjusted, but the door may also be field adjusted.

Do the following to adjust the doors:

1. To release door tension, open the door to 90° and lift up the door from the bottom. Lift the torsion rod out of the star pattern in the bottom hinge plate. (The door should be lifted out of the star pattern in the hinge plate to prevent any damage to the star pattern.)
2. Use a ½ in. open end wrench to tighten the torsion of the door. Adjust tension with each audible click. Doors should be adjusted to 4 clicks, more if needed. Door must be properly resealed in star pattern of hinge plate after torsion tension is applied.

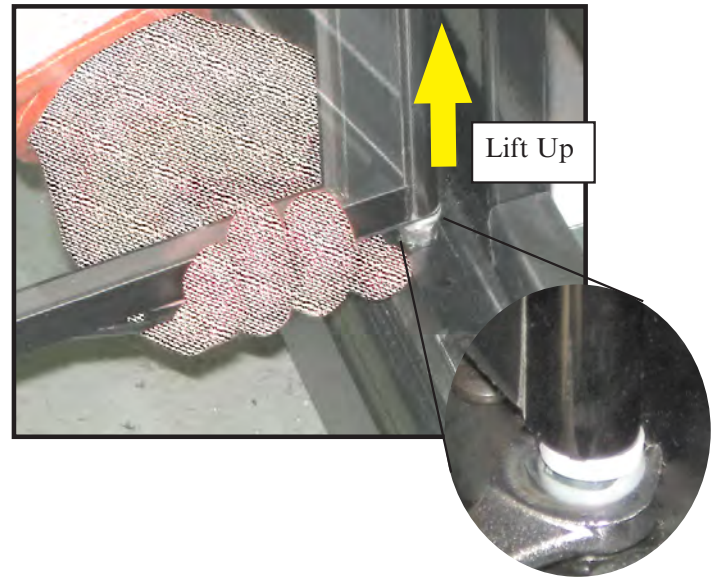

## REPLACING LED VERTICAL MULLION LIGHT BARS

LED vertical mullion lights are an available lighting option for EcoVision doors. Center fixtures illuminate the middle of the case, and the end fixtures illuminate the ends, or sides of the case.

These LEDs have different shaped lenses. They are not to be interchanged. Contact your Hussmann representative to order replacements.

The light bars are attached to the door mullions with mounting clips, and can be replaced similar to the canopy lights — just remove them from the mounting clips, and connect new wires at quick connect.

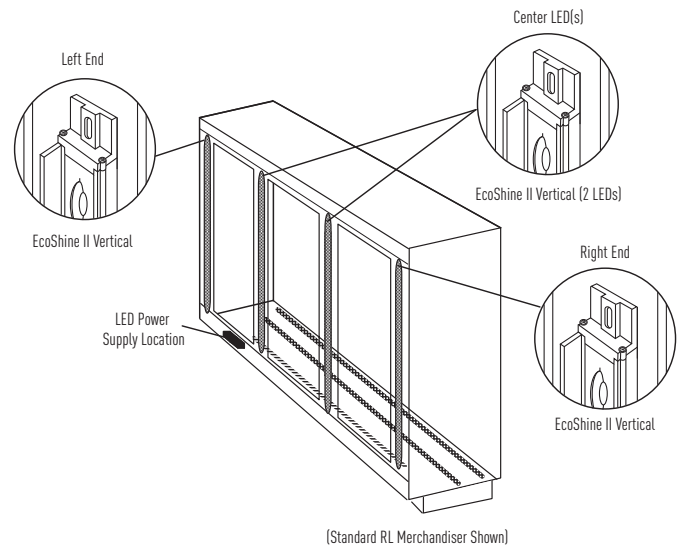

## 1-16 INSTALLATION

### Sealing Lineup Joints (all cases)

The joint between the two joined case must be sealed for sanitation. Apply Butyl tape across the case joint. Apply a long, continuous bead of silicone to fill any gaps between the cases.

Be sure to start from the back and go all the way to the air return as shown in the illustration below.

### **⚠ WARNING**

- » Use caution when working around refrigeration lines or water lines, damage to equipment and personal injury could occur.



**IMPORTANT** Fill any gaps between cases with silicone.

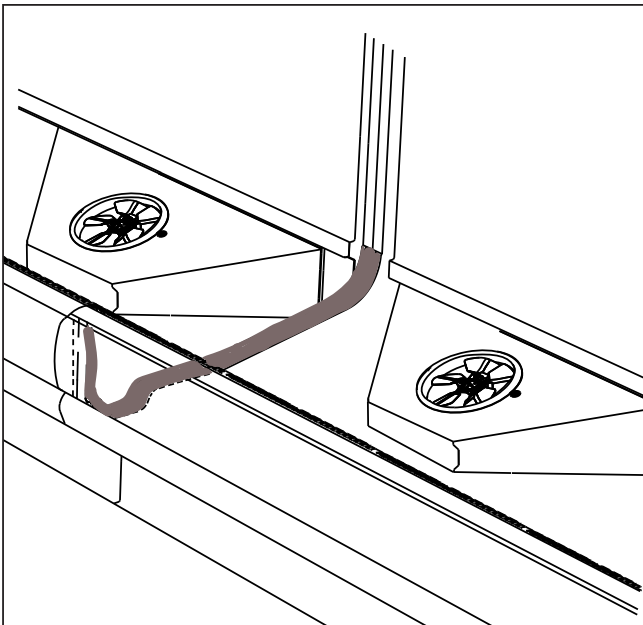

**Apply Butyl Tape**

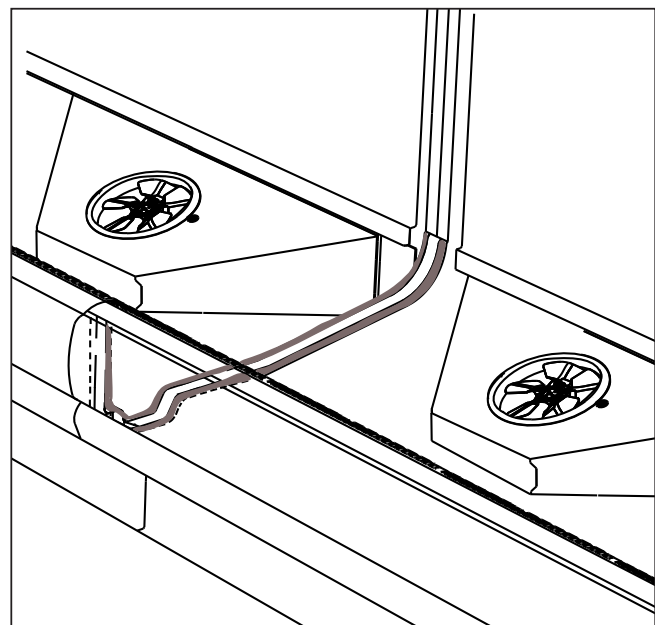

**Apply Neutral Curing  
Silicone Sealant**

**Apply Neutral Curing Silicone Sealant  
in any gaps between the Case Joints.**

















**INSTALLING END ASSEMBLIES**

Remove shipping brace. Brace screws will be replaced with shorter screws found in packout kit. Ensure Nut Retainers are in place. Apply Gaskets and Silicone to End Frame.

Apply 1/2 x 1/2 in. (12.7 mm) x (12.7 mm) gaskets into the case channels. Check that the gasket is properly inserted into the entire length of the channels with no gaps. Apply silicone between case end cap and end.

FIELD INSTALLED HARDWARE	Multi Deck Qty/Each	Convertible Qty/Each	Single Deck Qty/Each	View End Multi Deck Qty/Each
<b>Description</b>				
SEALER SILICONE ADHESIVE	1	1	1	1
GASKET 1/2 X 1/2 X 180	1	1	1	1
SCREW SM 10-16X3/4 HX WASHER	1	1	1	N/A
BOLT 5/16 x 2 3/4 GRADE 5 ZINC PLATED TAP*	4	2	1	5
BOLT- TAP, 5/16 x 4 1/2, STEEL, ZINC FINISH, GR5	1	1	1	1
WASHER-FLAT 5/16" ZINC*	7	4	2	8
NUT-HEX 5/16 STEEL ZINC FINISH GRADE 8*	3	2	2	4
NUT-PUSH 5/16" RETAINER STEEL ZINC*	2	1	1	2
NUT-J RETAINER 5/16*	2	1	N/A	2
BUTTON-PLUG 7/8 DIA*	5	3	2	6

\*Quantities may vary depending on which type of end is to be placed on case.

- Screw-sm #10 x 3/4 Hex Washer  
- Bolt-5/16 x 2 3/4  
- Bolt-5/16 x 4 1/2  
- Washer Flat-5/16  
- Nut Hex-5/16  
- Nut-Push 5/16  
- Nut-J Retainer  
- Button-Plug  

**IMPORTANT:**

Do not pull cases together with bolts. Cases must be moved together as close as possible. Follow sequence balloons to tighten bolts.

Apply case end gasket to only one side of case joint.

Remove end shipping braces as described on Page 1-4.

Cases must be leveled as described on Page 1-5.

Removed any casters - if installed.

Install case lineup from left to right.

Remove shelves, display racks, pans & interior back panels at the joining area.

Insert gasket into case channels the entire length with no gaps.

Do not stretch gasket, especially around corners.

Do not butt gaskets, always overlap them.

Remove paper backing after gasket has been applied.

Perimeter gasket is required by NSF.

Apply a continuous bead of neutral curing silicone sealant.

Joints must be air tight to prevent formation of ice or condensation.

# 1-18 INSTALLATION

## CASE END INSTALLATION MULTI-DECK (REAR-LOAD & DOOR)

Refer to detail views

### LEGEND:

A = 1/2 x 1/2 INCH GASKET

B = NEUTRAL CURING SILICONE SEALANT

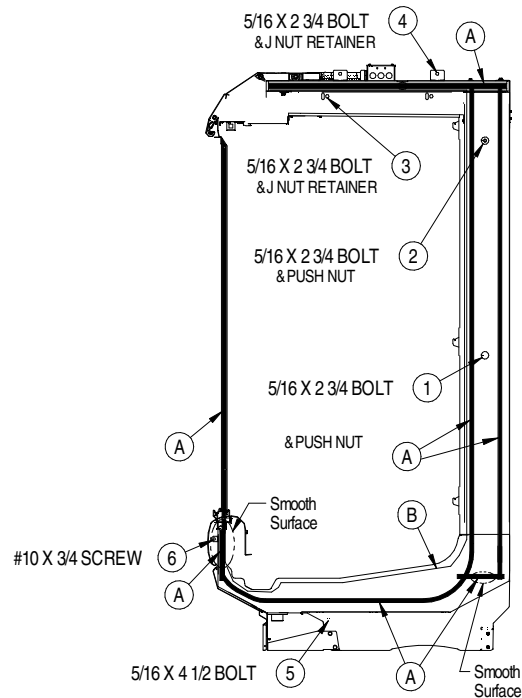
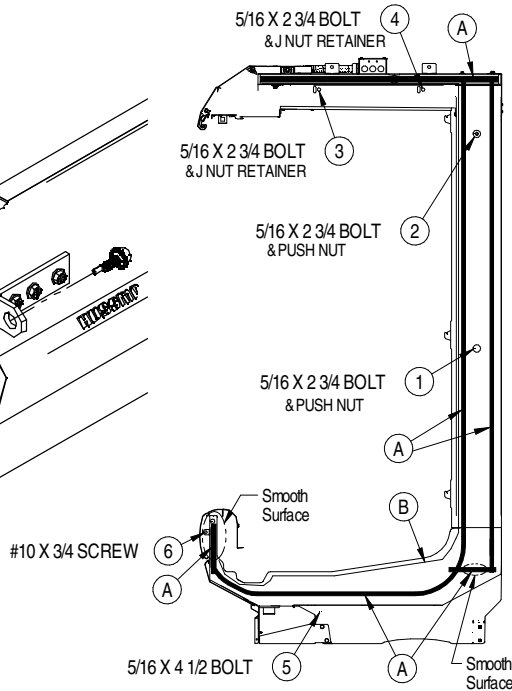
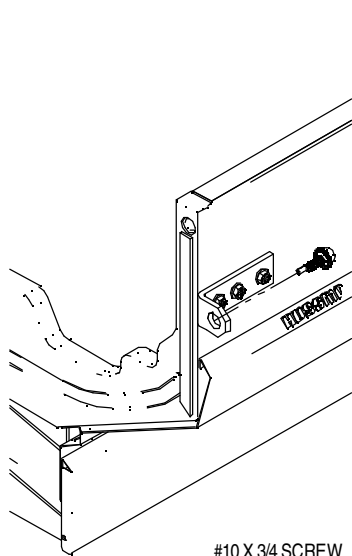
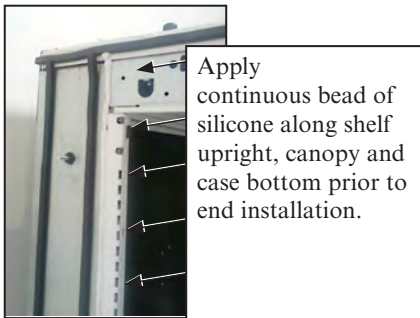
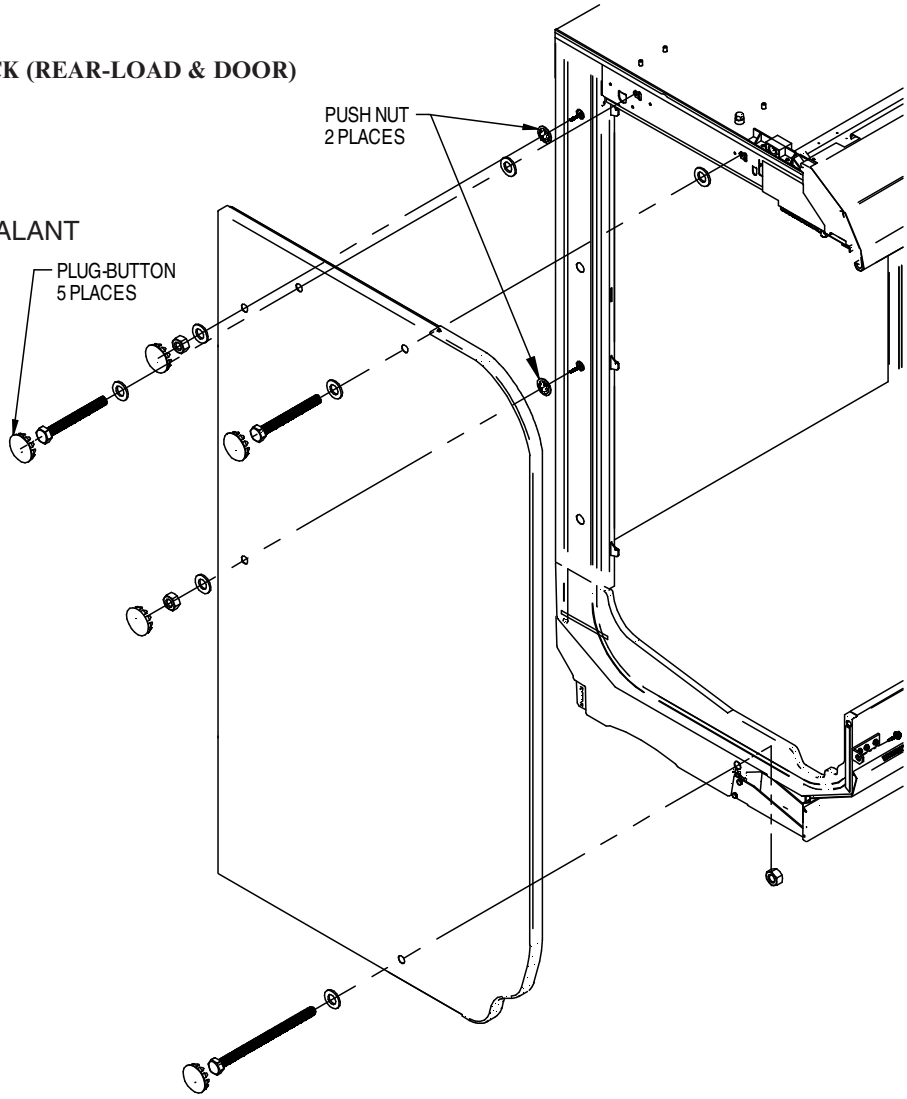

**CASE VIEW END INSTALLATION MULTI-DECK (REAR-LOAD & DOOR)**

Refer to detail views

**LEGEND:**

A = 1/2 x 1/2 INCH GASKET

B = NEUTRAL CURING SILICONE SEALANT

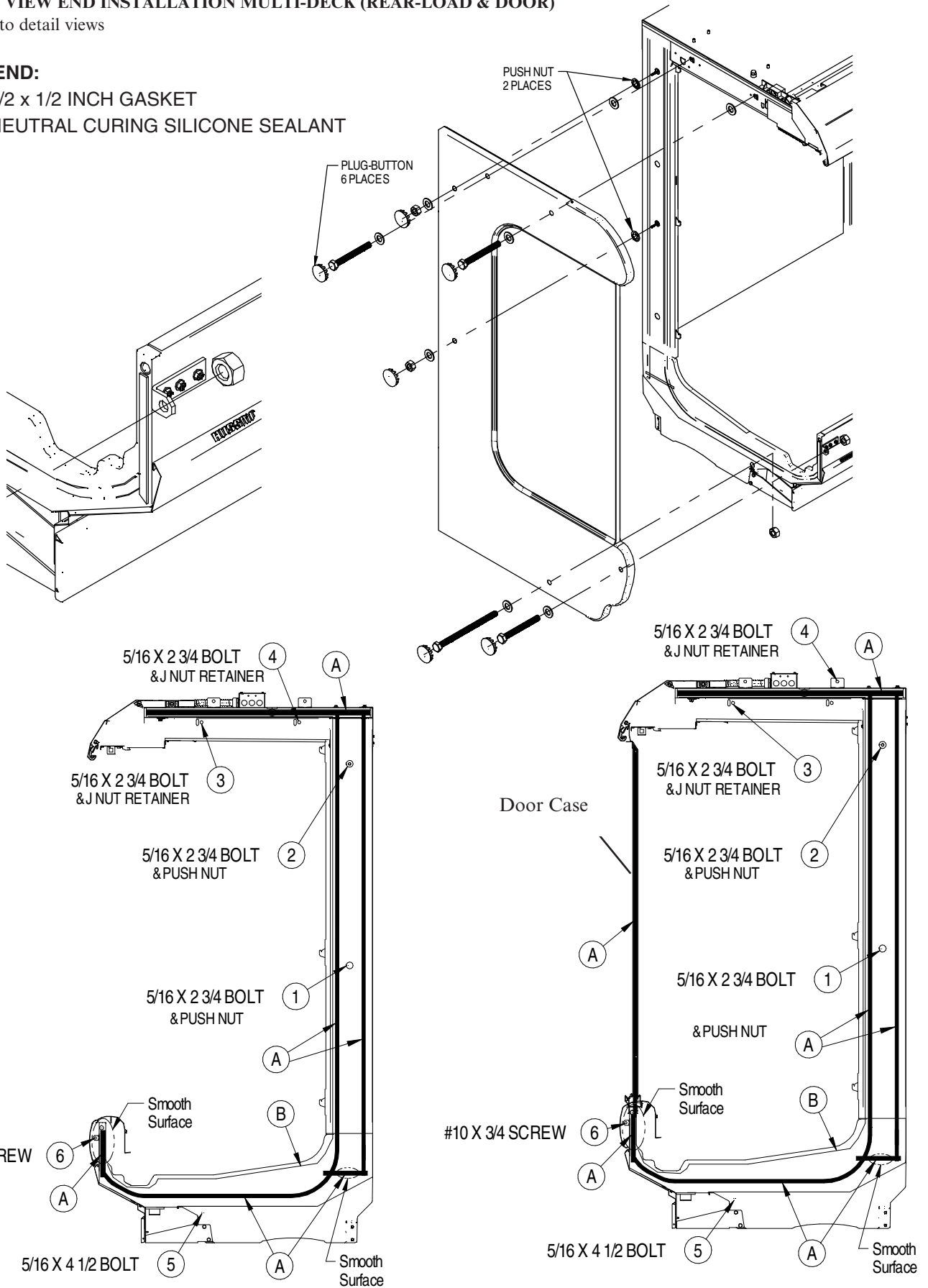





















# 1-20 INSTALLATION PARTITION HARDWARE

Remove shipping brace. Brace screws will be replaced with shorter screws found in packout kit. Ensure Nut Retainers are in place. Apply Gaskets and Silicone to End Frame.

Apply 1/2 x 1/2 in. (12.7 mm) x (12.7 mm) gaskets into the case channels. Check that the gasket is properly inserted into the entire length of the channels with no gaps. Apply silicone between case end cap and end.

Description	Alt Canopy Applications	Multi Deck/Door Same Case Qty/ Each	Multi Deck/Door Different Case Qty/ Each	Convertible Different Case Qty/ Each
SEALER SILICONE ADHESIVE	Refer to Multi Deck Different Case	2	2	2
GASKET 1/2 X 1/2 X 180	Refer to Multi Deck Different Case	2	2	2
SCREW-SHEET METAL #8 X 5/8 PHIL HX HD	3 or 4	1	1	1
SCREWSM10-16X3/4 HX WASHER	1	2	2	2
BOLT HEX 1/4 x 1 1/2	Refer to Multi Deck Different Case	N/A	2	N/A
BOLT HEX 1/4 x 2 1/4*	1	N/A	2	2
BOLT HEX 1/4 x 4.0	Refer to Multi Deck Different Case	N/A	1	N/A
BOLT HEX 5/16 x 2 3/4*	Refer to Multi Deck Different Case	1	4	2
BOLT-HEX 5/16 x 4 1/2	Refer to Multi Deck Different Case	2	1	N/A
BOLT-HEX 5/16 x 7.0*	Refer to Multi Deck Different Case	2	N/A	N/A
BOLT-HEX 5/16 x 8.0	Refer to Multi Deck Different Case	1	N/A	1
WASHER-FLAT 1/4*	1	N/A	5	2
WASHER-FLAT 5/16*	Refer to Multi Deck Different Case	8	5	4
NUT-HEX 5/16*	Refer to Multi Deck Different Case	7	3	4
NUT-HEX 3/8-24 SERRATED FLANGE	1	4	2	N/A
NUT-PUSH5/16" RETAINERSTEEL ZINC*	Refer to Multi Deck Different Case	2	N/A	N/A
NUT-J RETAINERS/16"	Refer to Multi Deck Different Case	1	2	1
BRACKET-CASE JOINING	N/A	4	2	N/A
BRACKET-CANOPY (ALT APPLICATIONS)	1	N/A	N/A	N/A
BRACKET-UNIBODY (ALT APPLICATIONS)	1	N/A	N/A	N/A
BUTTON-PLUG7/8 DIA*	Refer to Multi Deck Different Case	N/A	2	1
BRACKET-CLOSEOFF SPLASHGUARD	Refer to Multi Deck Different Case	1	1	1
CLOSEOFF-SPLASHGUARD	Refer to Multi Deck Different Case	1	1	1

\*Quantities may vary depending on which type of end is to be placed on case.

- Screw-Sheet Metal #8 x 5/8 
- Screw-sm #10 x 3/4 Hex Washer 
- Bolt-1/4 x 1 1/2 
- Bolt-1/4 x 2 1/4 
- Bolt-1/4 x 4 
- Bolt-5/16 x 2 3/4 
- Bolt-5/16 x 4 1/2 
- Bolt-5/16 x 7 
- Bolt-5/16 x 8 
- Washer Flat-1/4 
- Washer Flat-5/16 
- Nut Hex-5/16 
- Nut Hex-3/8 Serr Flange 
- Nut-Push 5/16 
- Nut-J Retainer 
- Bracket-Case Joining 
- Bracket-Canopy (Alt Applications) 
- Bracket-Unibody (Alt Applications) 
- Button-Plug 
- Bracket-Closeoff Splashguard 
- Closeoff-Splashguard 

### IMPORTANT:

Do not pull cases together with bolts. Cases must be moved together as close as possible. Follow sequence balloons to tighten bolts.

Apply case end gasket to only one side of case joint.

Remove end shipping braces as described on Page 1-4.

Cases must be leveled as described on Page 1-5.

Removed any casters - if installed.

Install case lineup from left to right.

Remove shelves, display racks, pans & interior back panels at the joining area.

Insert gasket into case channels the entire length with no gaps.

Do not stretch gasket, especially around corners.

Do not butt gaskets, always overlap them.

Remove paper backing after gasket has been applied.

Perimeter gasket is required by NSF.

Apply a continuous bead of neutral curing silicone sealant.

Joints must be air tight to prevent formation of ice or condensation.

**MULTI DECK (REAR LOAD & DOOR)  
SAME CASE PARTITIONS**

Refer to detail views

**LEGEND:**

A = 1/2 x 1/2 INCH GASKET

B = NEUTRAL CURING SILICONE SEALANT

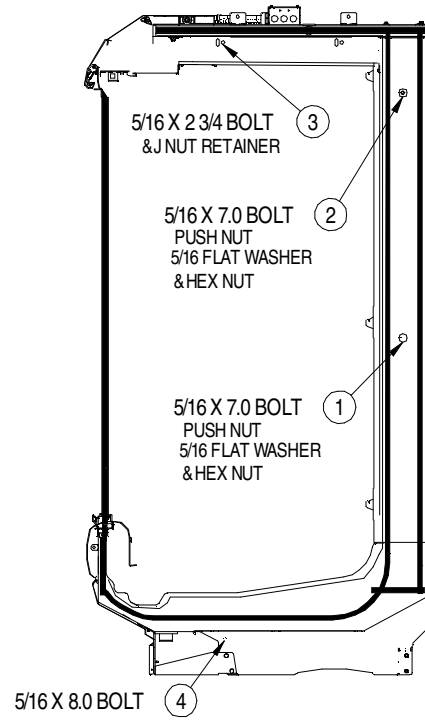
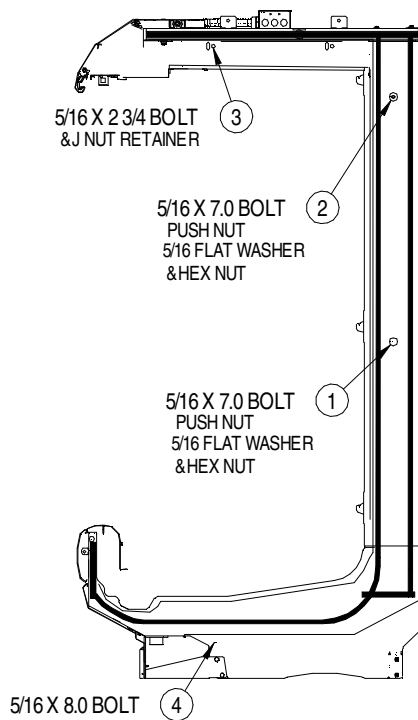
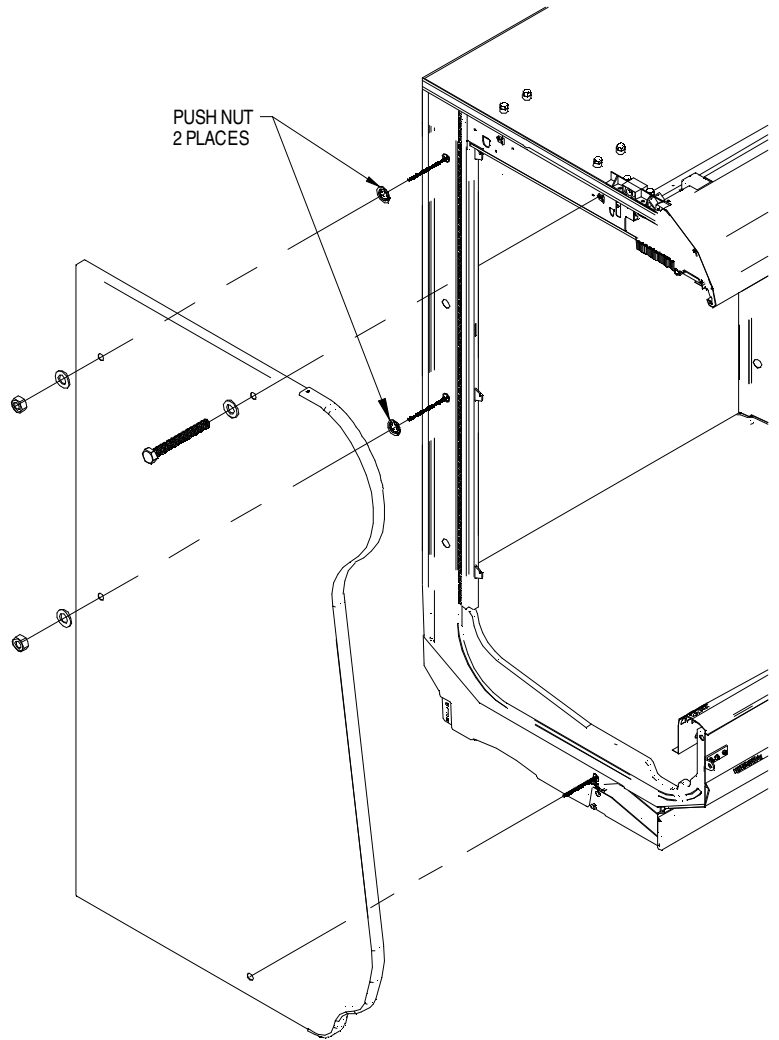

**MULTI DECK (REAR-LOAD & DOOR)  
DIFFERENT CASE PARTITIONS**

Refer to detail views

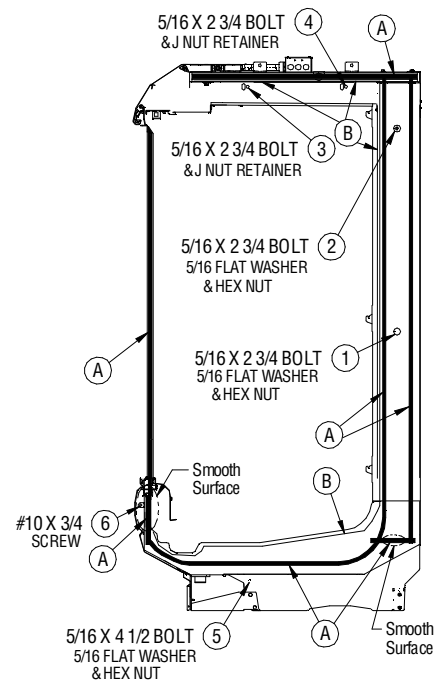
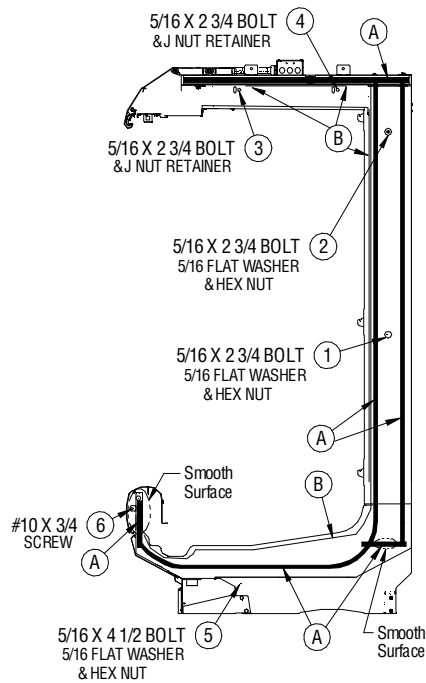
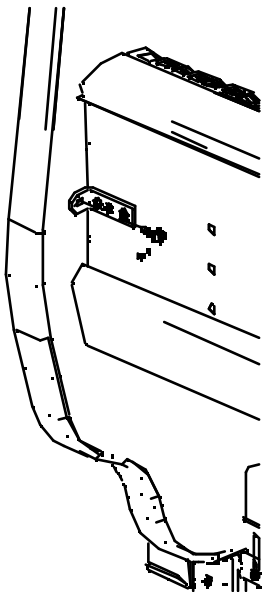
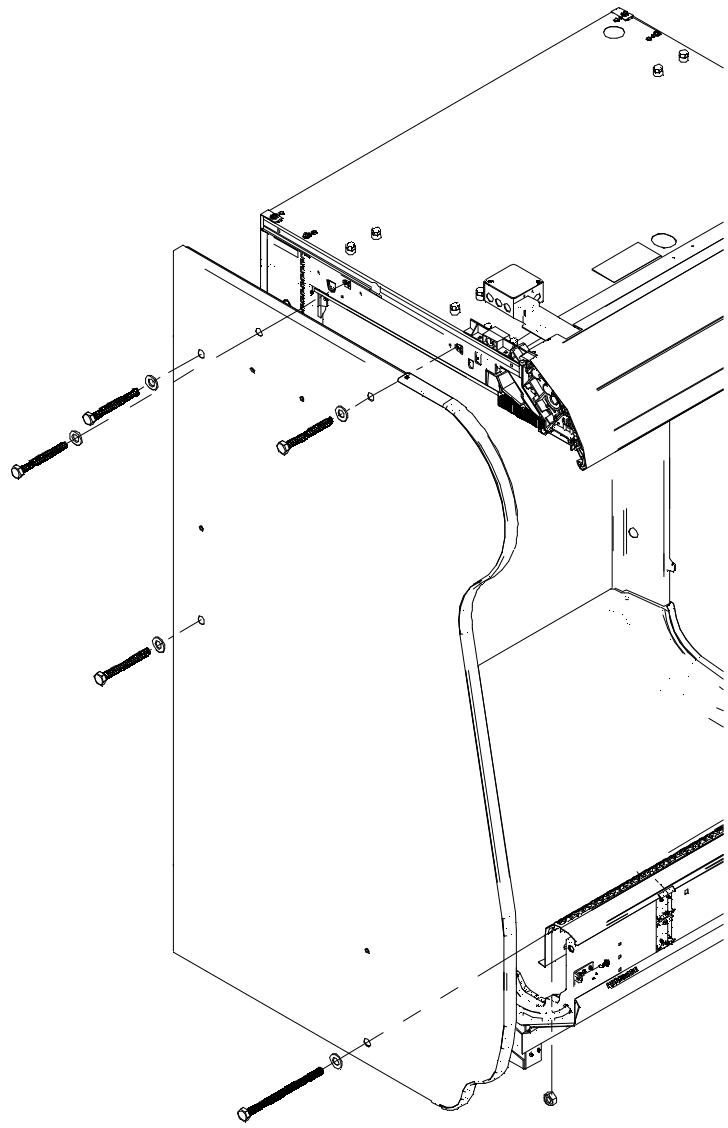
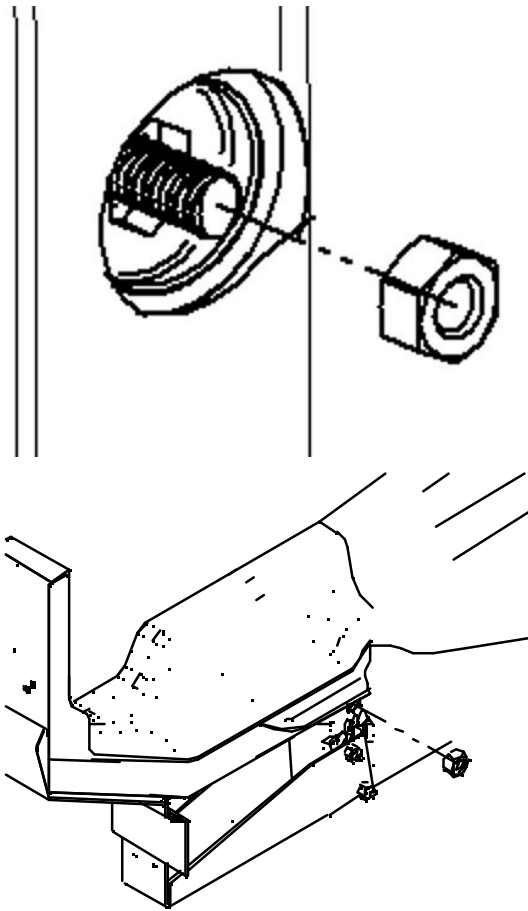

**MULTI DECK (REAR-LOAD & DOOR)  
DIFFERENT CASE PARTITIONS  
CONTINUED**

Refer to detail views

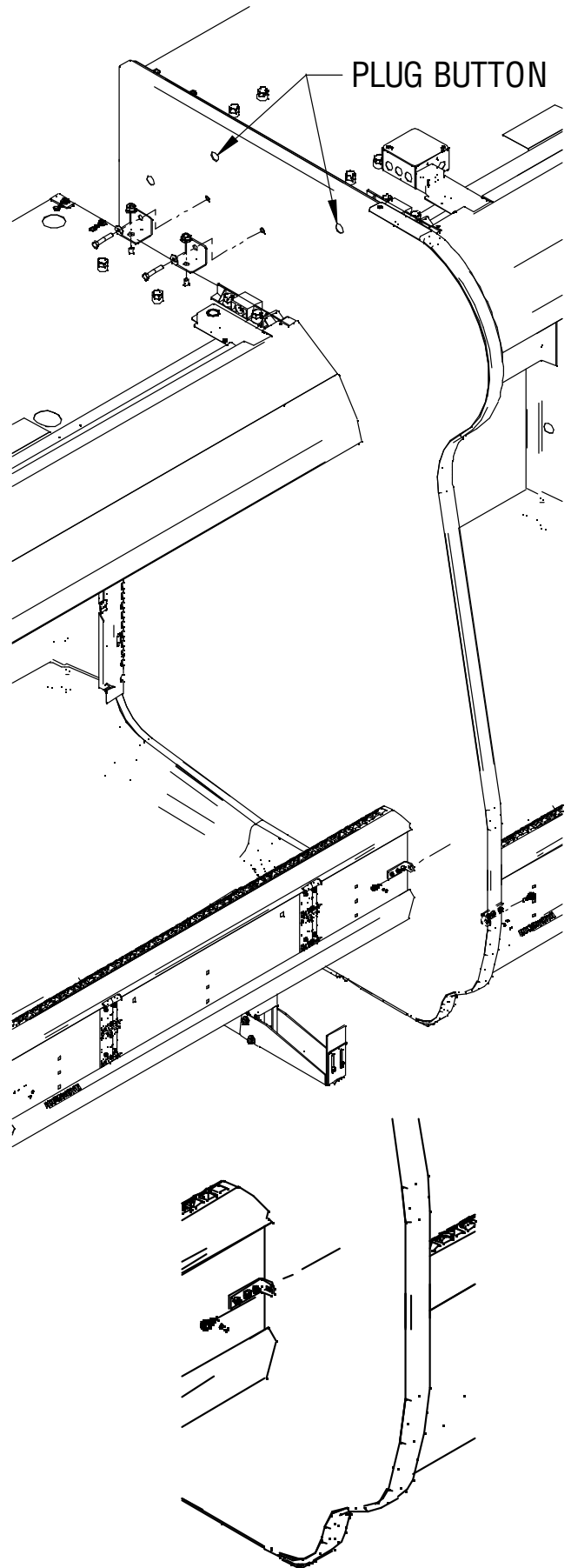
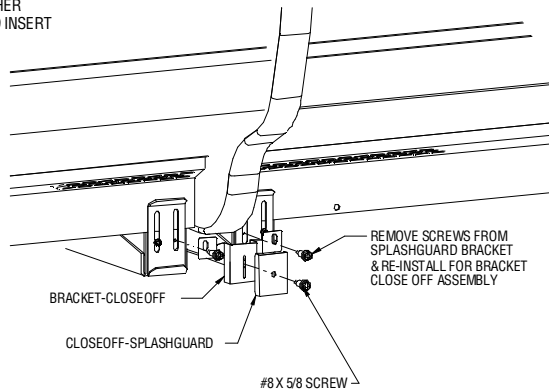
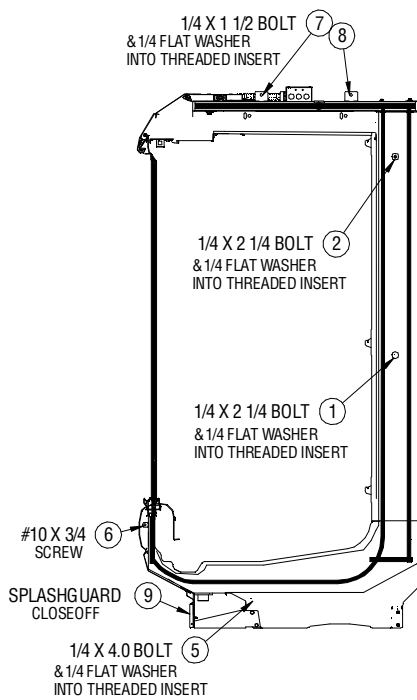
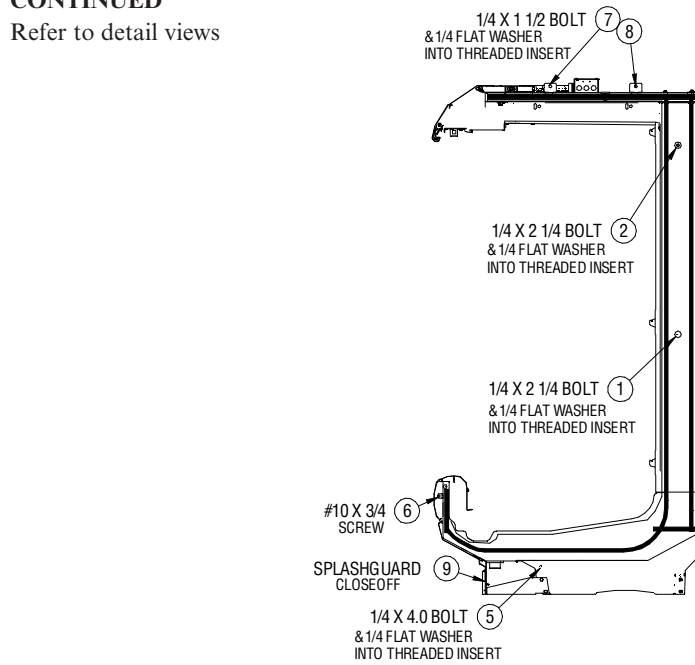



DIFFERENT CASE PARTITIONS MULTI-DECK (REAR-LOAD & DOOR)  
ALTERNATIVE CANOPY APPLICATIONS  
CONTINUED

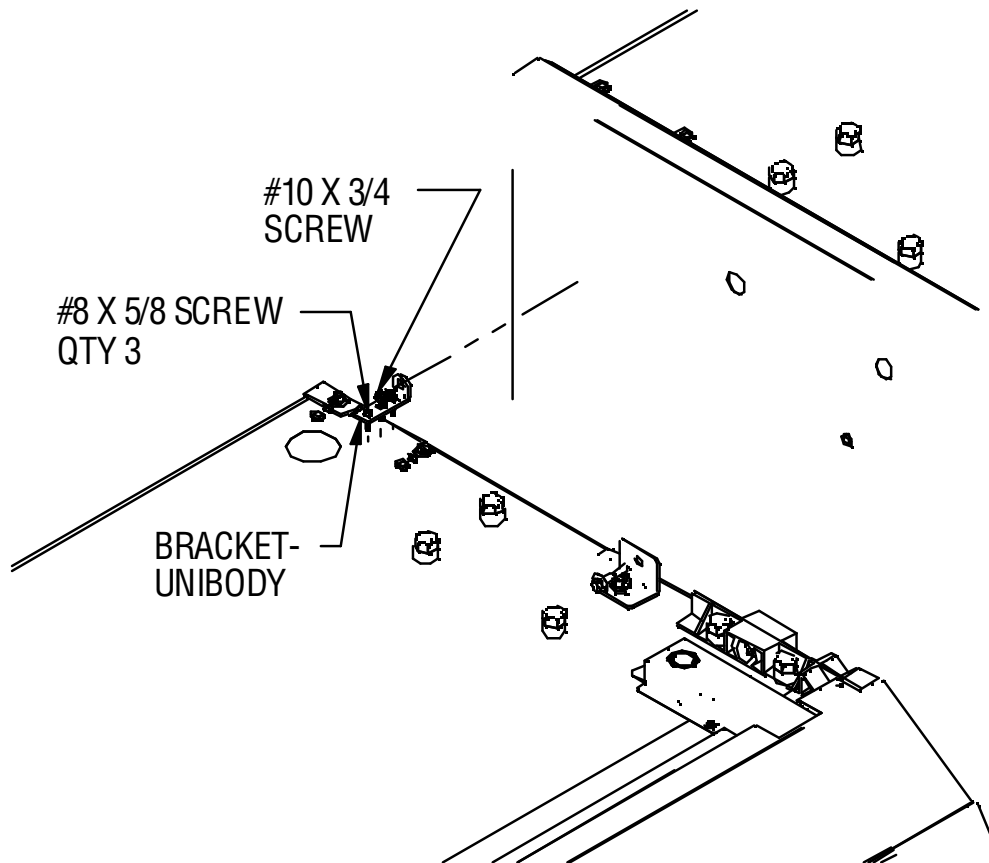
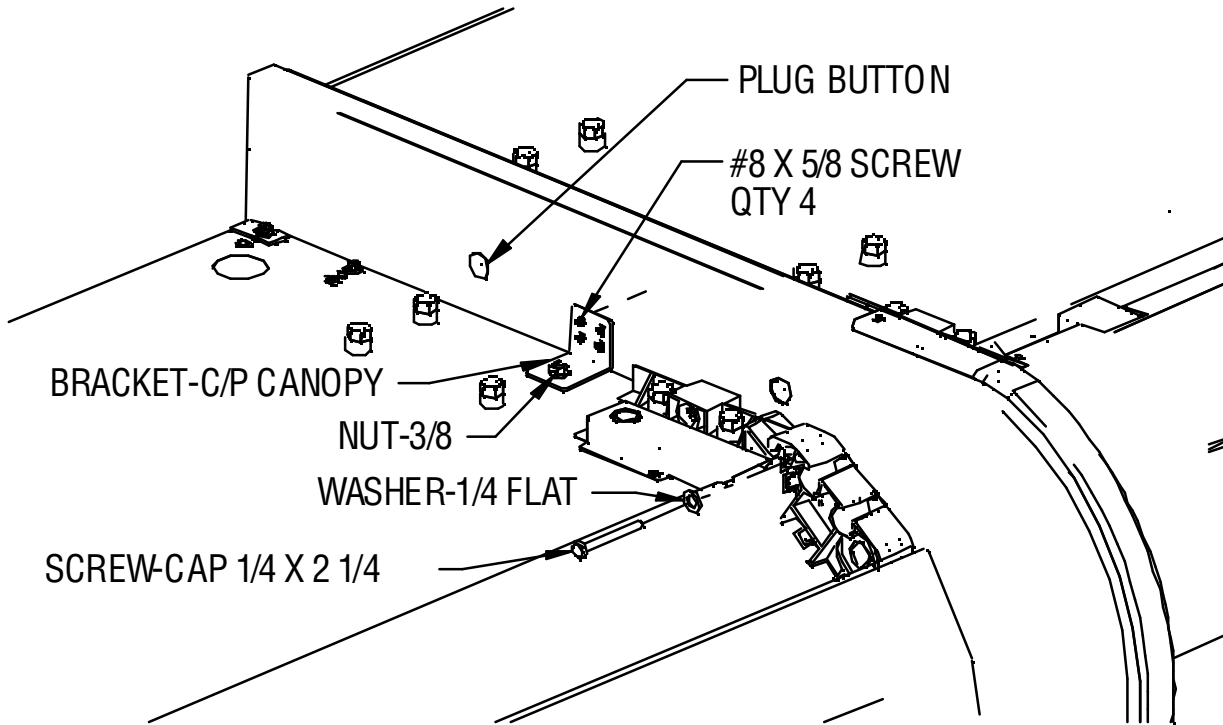

Refer to detail views





## ACRYLIC PARTITION HARDWARE

Description	Multi Deck Qty/Each	Convertible Qty/Each
PARTITION-ACRYLIC	1	1
BRACKET-CANOPY	1	1
BRACKET-RETURNAIRGRILL	N/A	1
SCREWSM#8 x 5/8 HEX	3	4
SCREWMACHINE#8 x 1/2 PHILL	3	4
LOCKWASHER-#8 EXT TOOTH	3	4
NUT-#8 MACHINEHEX	3	4

Screw-Sheet Metal #8 x 5/8  

Screw-Machine #8 x 1/2 Phill  

Lockwasher-Ext Tooth #8  

Nut Machine Hex-#8  

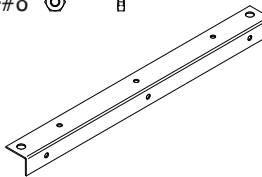
Bracket-Canopy Multideck 

Bracket-Canopy Convertible 

Bracket-Return Air Grill 

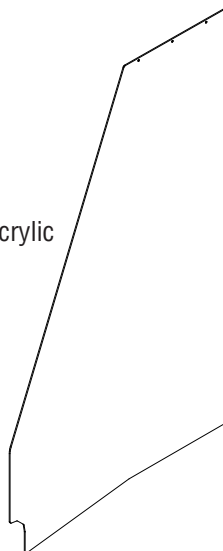
Partition-Acrylic 

MULTI-DECK

ACRYLIC PARTITIONS

Refer to detail views

ACRYLIC PARTITION  
TO BE MOUNTED  
BETWEEN TWO  
CASES ATTACH  
BRACKET TO ONLY  
ONE CASE

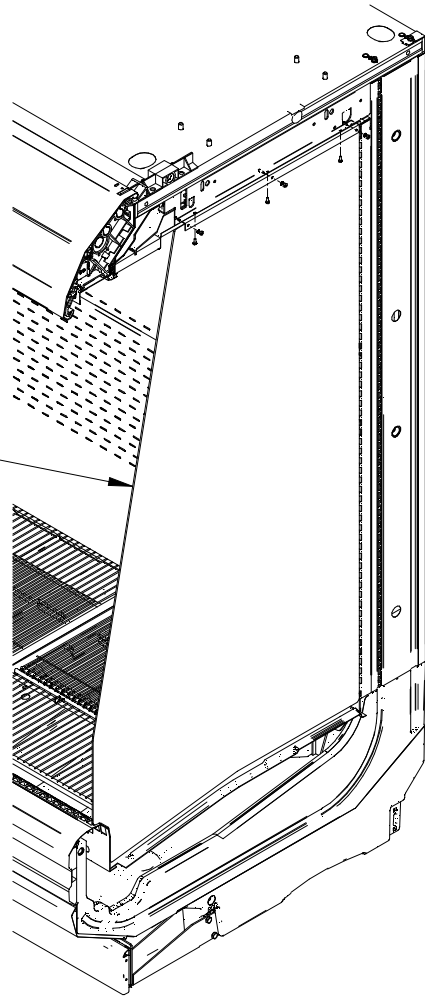

#8 X 1/2 MACHINE SCREW  
#8 EXT TOOTH LOCKWASHER  
& #8 MACHINE NUT  
3 PLACES

3

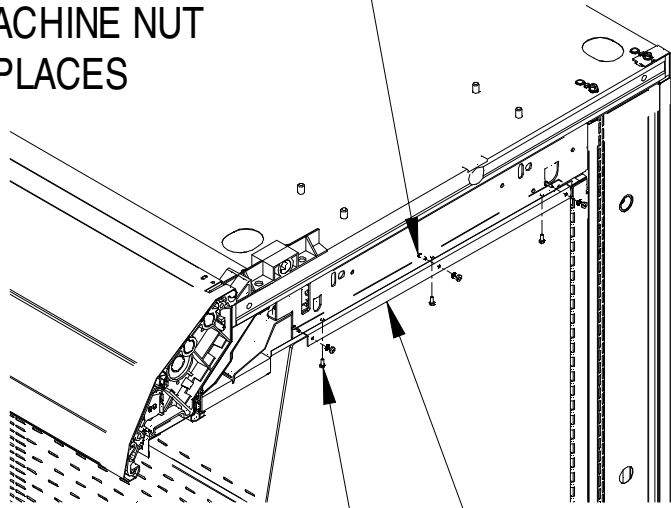

1 BRACKET-CANOPY

2 #8 X 5/8 SCREW  
3 PLACES

**CONVERTIBLE  
ACRYLIC PARTITIONS**  
Refer to detail views

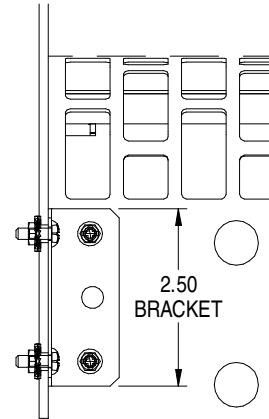

RETURN AIR GRILL VIEW  
APPROXIMATE LOCATION  
OF BRACKET

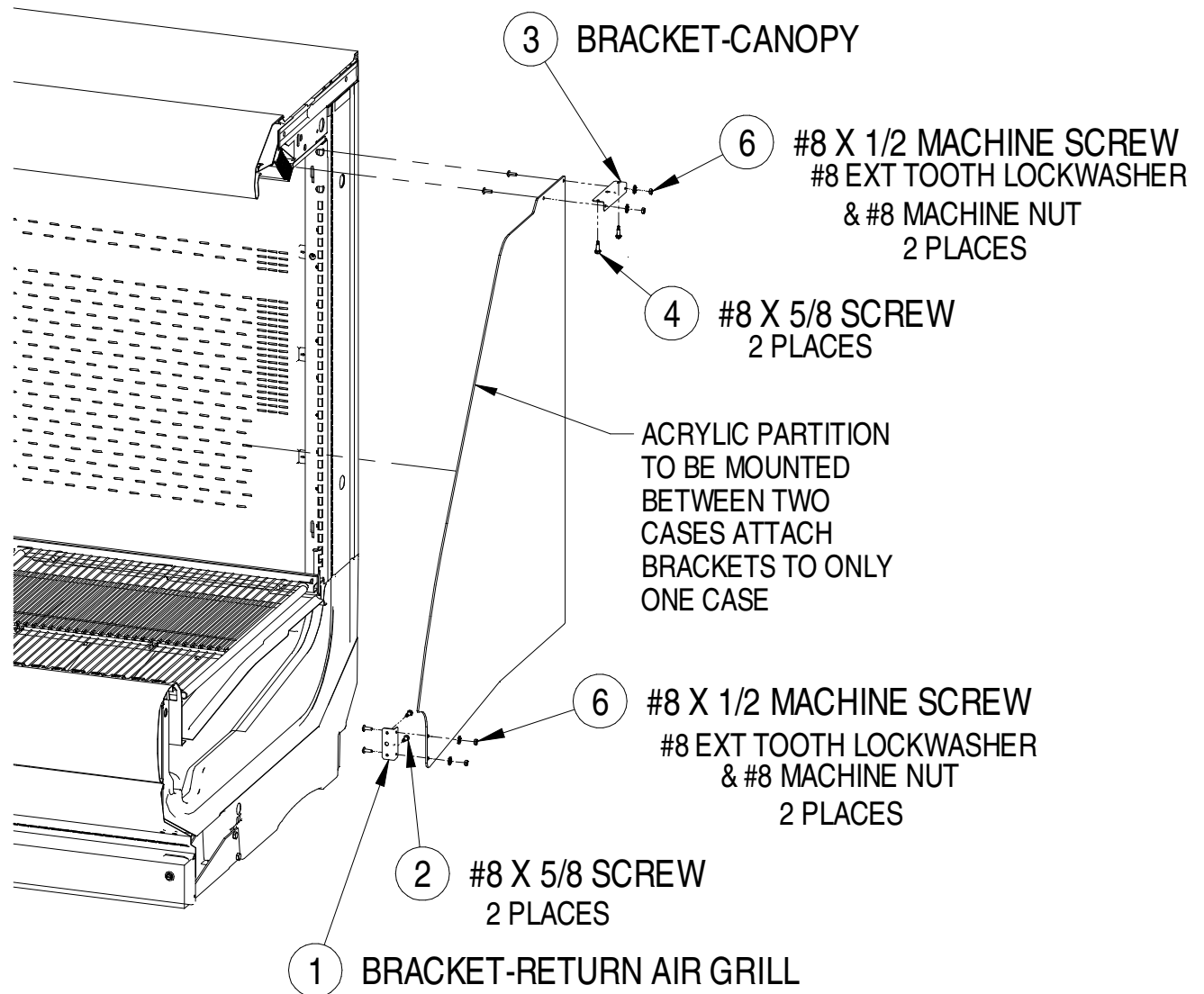

INSTALLING BUMPERS

1. Bumpers are packed out with the case and snap onto the bumper retainer. Gaskets are factory installed in the bumper retainers to provide support for the bumpers. Do not remove the gaskets.

2. Bumper joint inserts are provided with the case to disguise joints for a lineup of cases.

3. Start at the left end of the lineup. Install 3ft starter bumper first. Refer to bumper side view illustration to ensure the bumper is orientated correctly. Place top of bumper over bumper retainer, then snap bottom of bumper into place at bottom of retainer. Position internal joint trim between the starter bumper and full-length bumper.

4. Continue installing bumper(s) until the lineup is complete. The last piece of bumper will need to be cut so that it is flush with the right end cap. Use a fine tooth saw to cut the bumper vertically at a 90° angle.

5. Ensure joint trim is positioned behind bumper at all joints to close any gaps in the lineup. Remove protective film from bumper once installation is complete.

**NOTE** Bumpers come in two styles — Ellipse and Faceted.

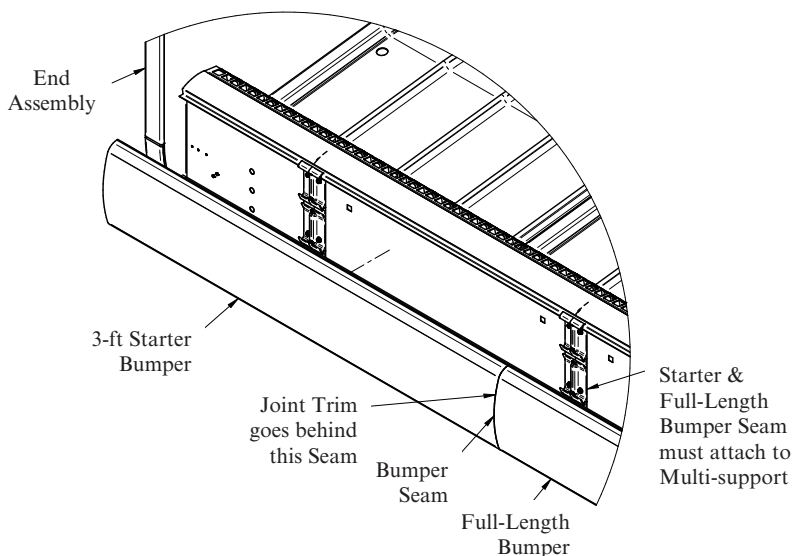
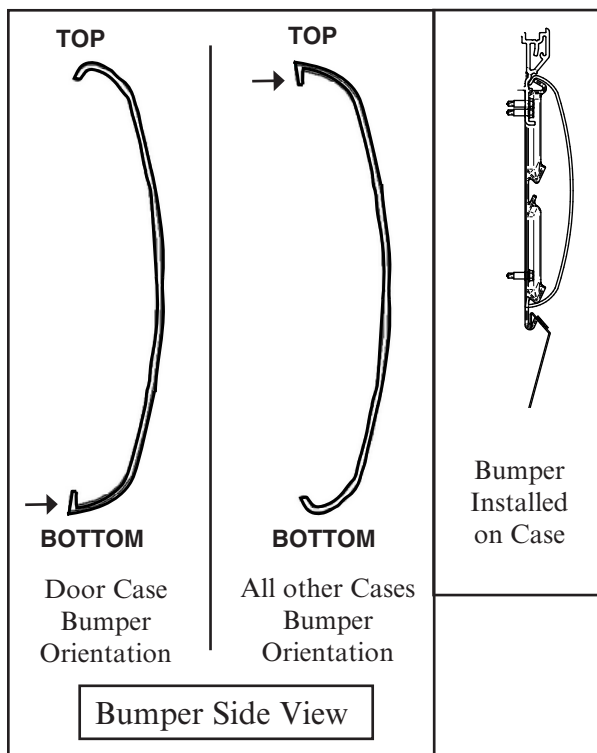
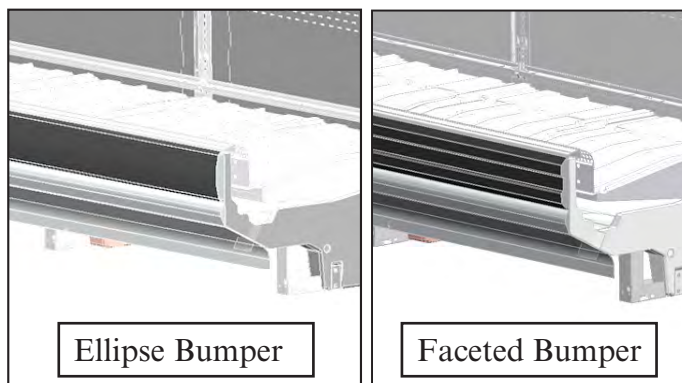

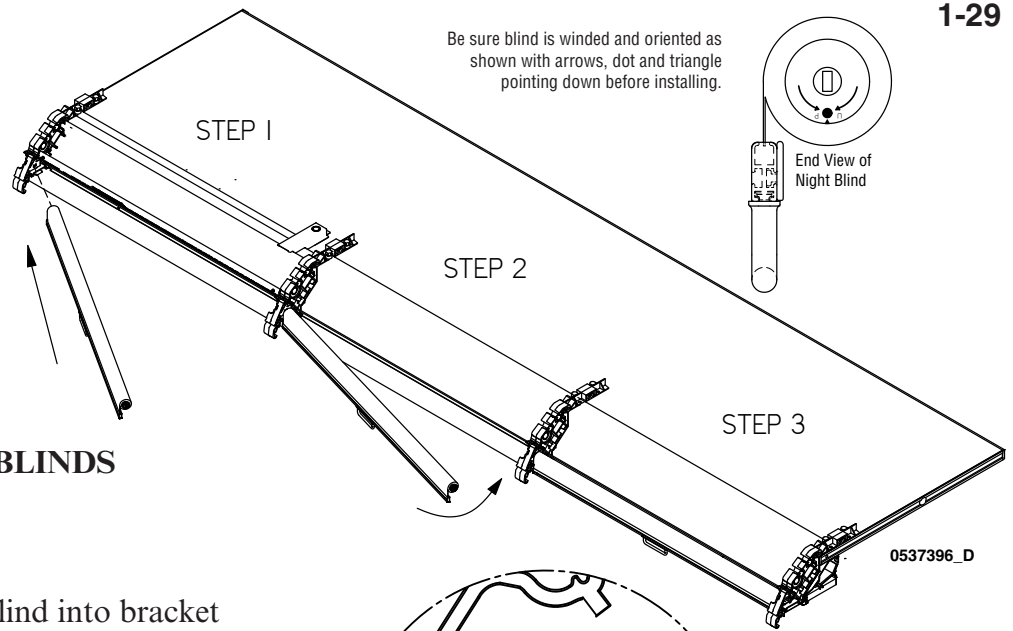

**INSTALLING NIGHT BLINDS**

**STEP 1**

Slide the lefthand night blind into bracket cutout.

**NOTE** Left section of case always uses the front cutout. Alternate front to back for remaining sections.

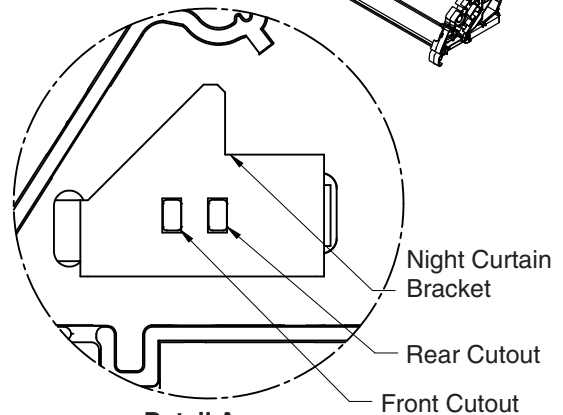

**Detail A**

Brackets Always on Left Side of Night Curtain

**STEP 2**

Swing righthand side of night blind into slot on side of canopy support arm.

**NOTE** Left section of case always uses the bottom slot. Alternate bottom to top for remaining sections.

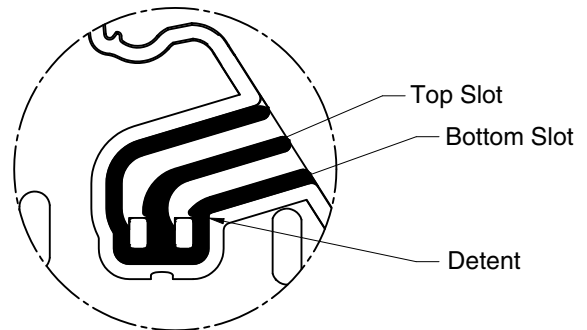

**Detail B**

Slots always on right side of night blind

**STEP 3**

Push/pull down on night blind slightly to slide pin past detent.

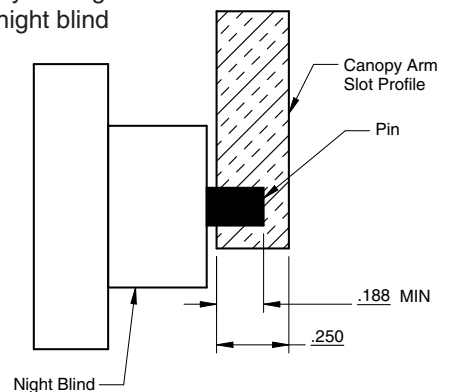

**STEP 4**

Check pin engagement to ensure at least 3/16" of pin is firmly in the slot.

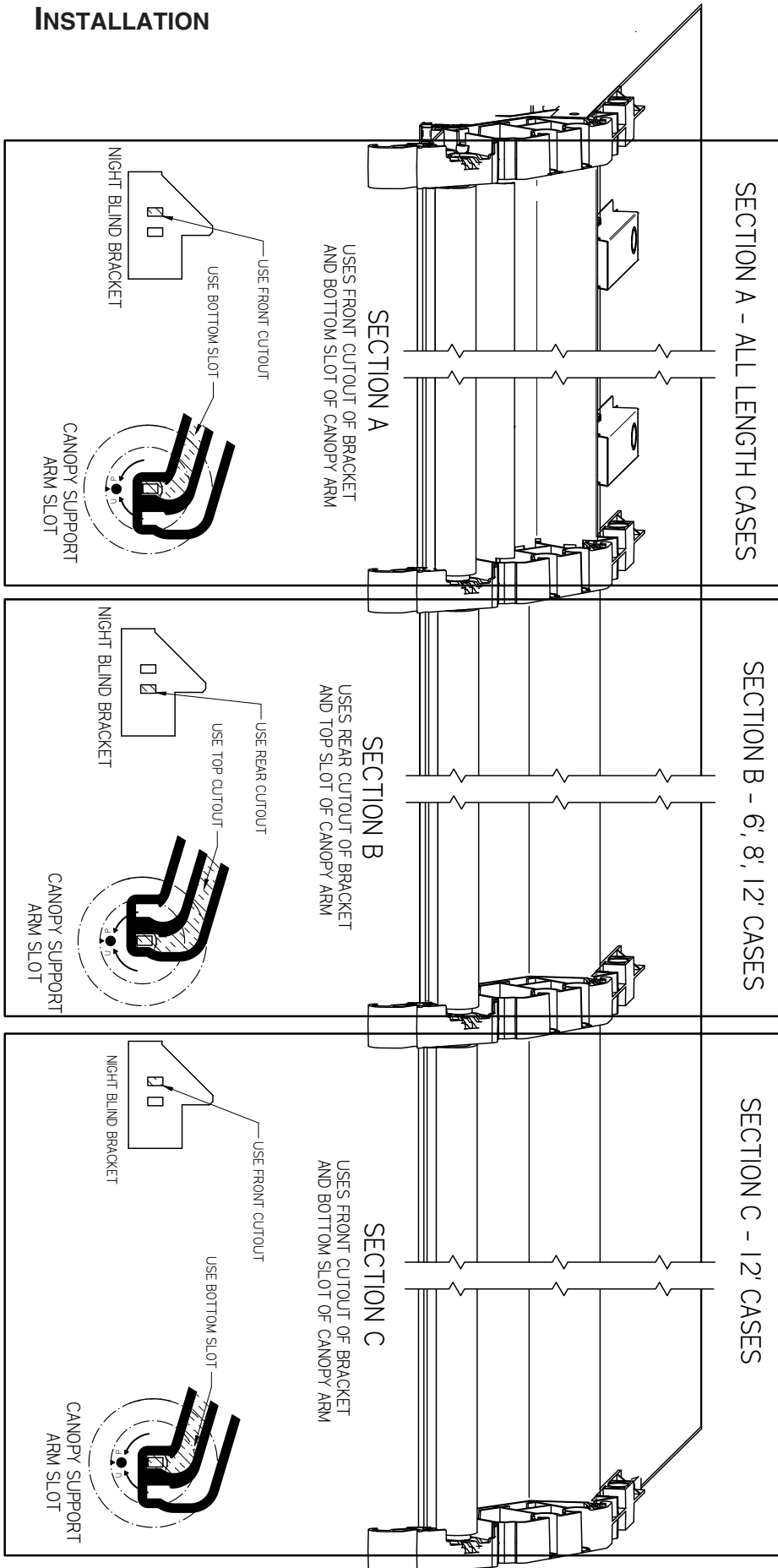

### LOADING BLIND SPRING

Night blinds are delivered pre-loaded. However, if it is necessary to load night blind spring, use a wrench (part number 0477098) to twist rectangular pin on right side of night blind. Twist clockwise 14 to 15 full revolutions.

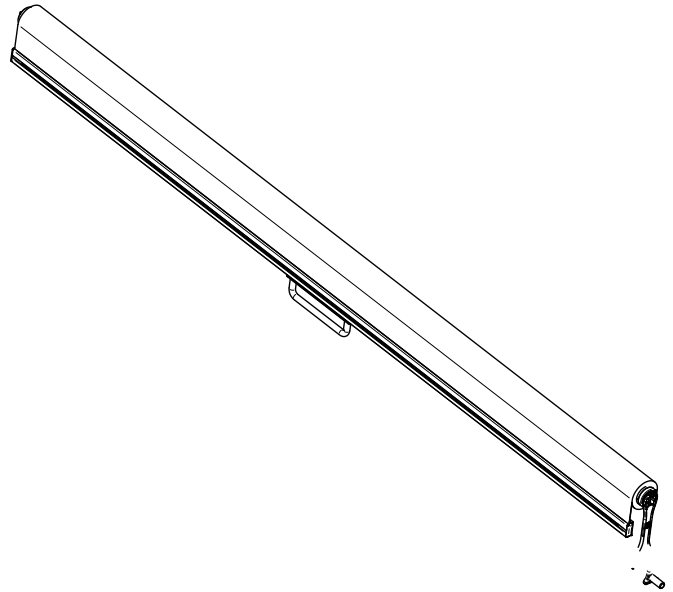

**NOTE**  **Keep arrow / dot / up pointed up while winding. Keep pointed down when installed.**

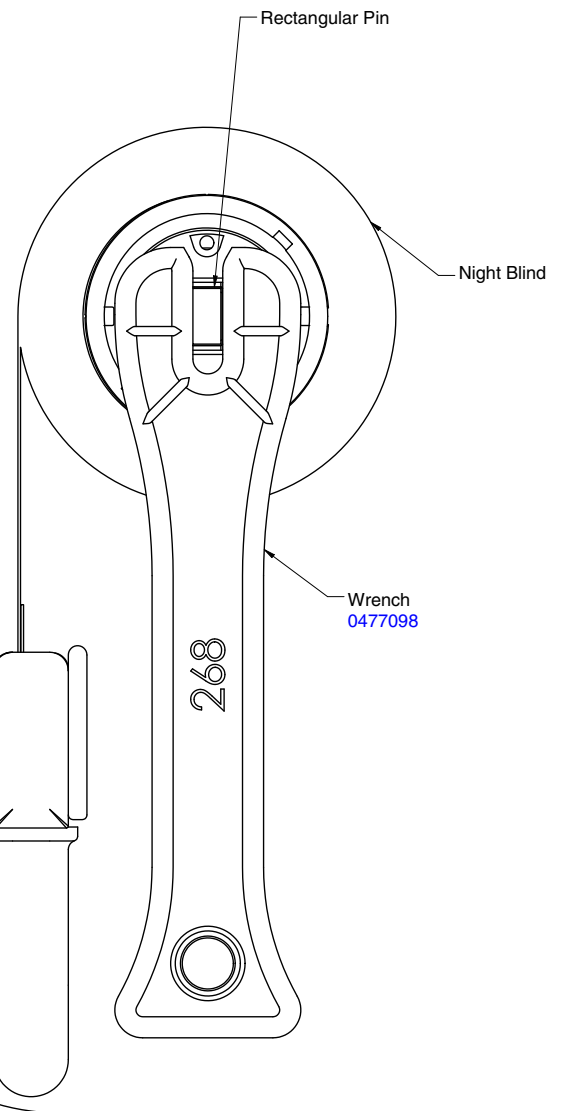

Image showing wrench tightening night blind

Reference Mark (triangle or circle) must be oriented upward when winding and downward during installation.

Night Blind Handle

Twist wrench clockwise for 14 to 15 revolutions



## TROUBLESHOOTING NIGHT BLINDS

## If night blind is not installed:

## STEP 1

Only install brackets on the lefthand support arm and each center support arm.

## STEP 2

On the righthand side of each arm, insert front tab of bracket into the front slot, then snap into the rear slot.

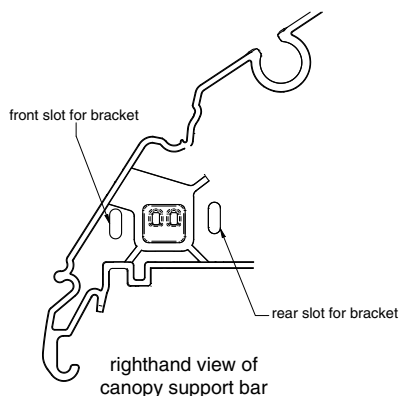
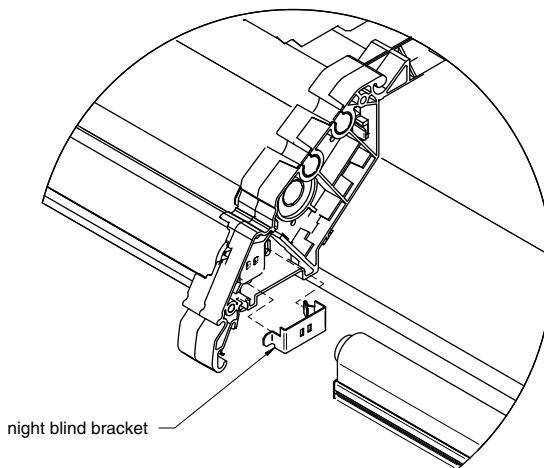

## If pin is too short or rounding out canopy arm:

## STEP 1

Remove night curtain from case

## STEP 2

Use pliers to pull metal pin out to desired length

## STEP 3

Replace night curtain into canopy

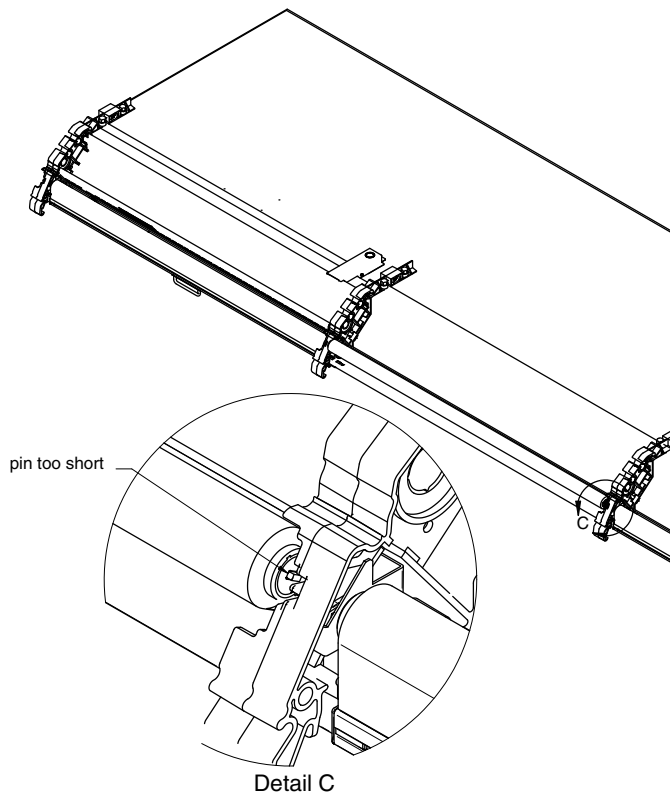

NOTE

Keep pointed down when installed.

## REFRIGERATION / ELECTRICAL / CONTROLLER

### REFRIGERANT

Freedom cases and condensing unit are shipped separately with the correct charge amount to equal the total charge needed for proper operation. Labels are placed on top of the case near the condensing unit connections that show the correct refrigerant type and total charge quantity.

When evacuating and re-charging, charge with the total quantity shown on this label. With the correct refrigerant charge, some vapor may be present in the sightglass. Charging to a “clear” sightglass may result in compressor failures due to excessive refrigerant.

### FIELD INSTALLATION OF CONDENSING UNIT

In some circumstances store doors may not be tall enough to pass the electrical components through the door. In this situation, the electrical components may be removed temporarily to pass under lower frame store doors.

Condenser mounting brackets are provided on top of the case with pilot holes with specific attachment points for the condensing unit base. The mounting brackets are located on the top right side of the case.

After mounting the condensing unit, the electrical box must be re-attached to the top. The condensate pan, if provided, is packed inside the case and must also be installed on top of the case and plugged into the receptacle provided. Exact component location is not critical; however, the components should be mounted in the general locations shown to ensure that electrical connections reach, and the condensate pan has adequate air flow from the condenser.

### **⚠ WARNING**

» Opening condensing unit electrical box exposes personnel to electrical hazard and should only be performed by a qualified service technician!

### NOTE:

EACH UNIT LENGTH (12FT, 8FT, 6FT, 4FT) HAS DIFFERENT LOCATIONS FOR CONDENSING UNIT AND ELECTRICAL COMPONENTS.

**IMPORTANT:** Pans must be installed level. Shim if needed.

### Condensate Evaporation Pan

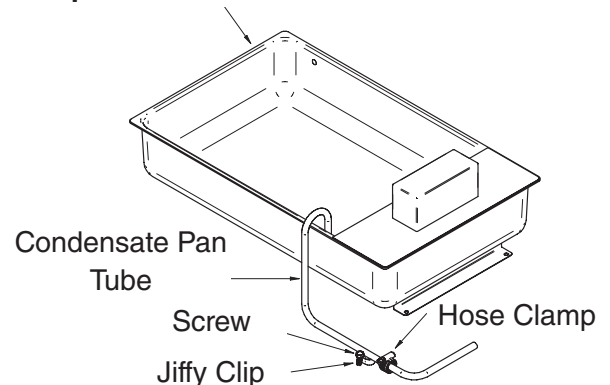

**FIELD-INSTALLED CONDENSING UNIT LOCATION  
(Air-cooled option)**

Rear mount condensate pump shown. Use this option only when rear of case is accessible after installation.

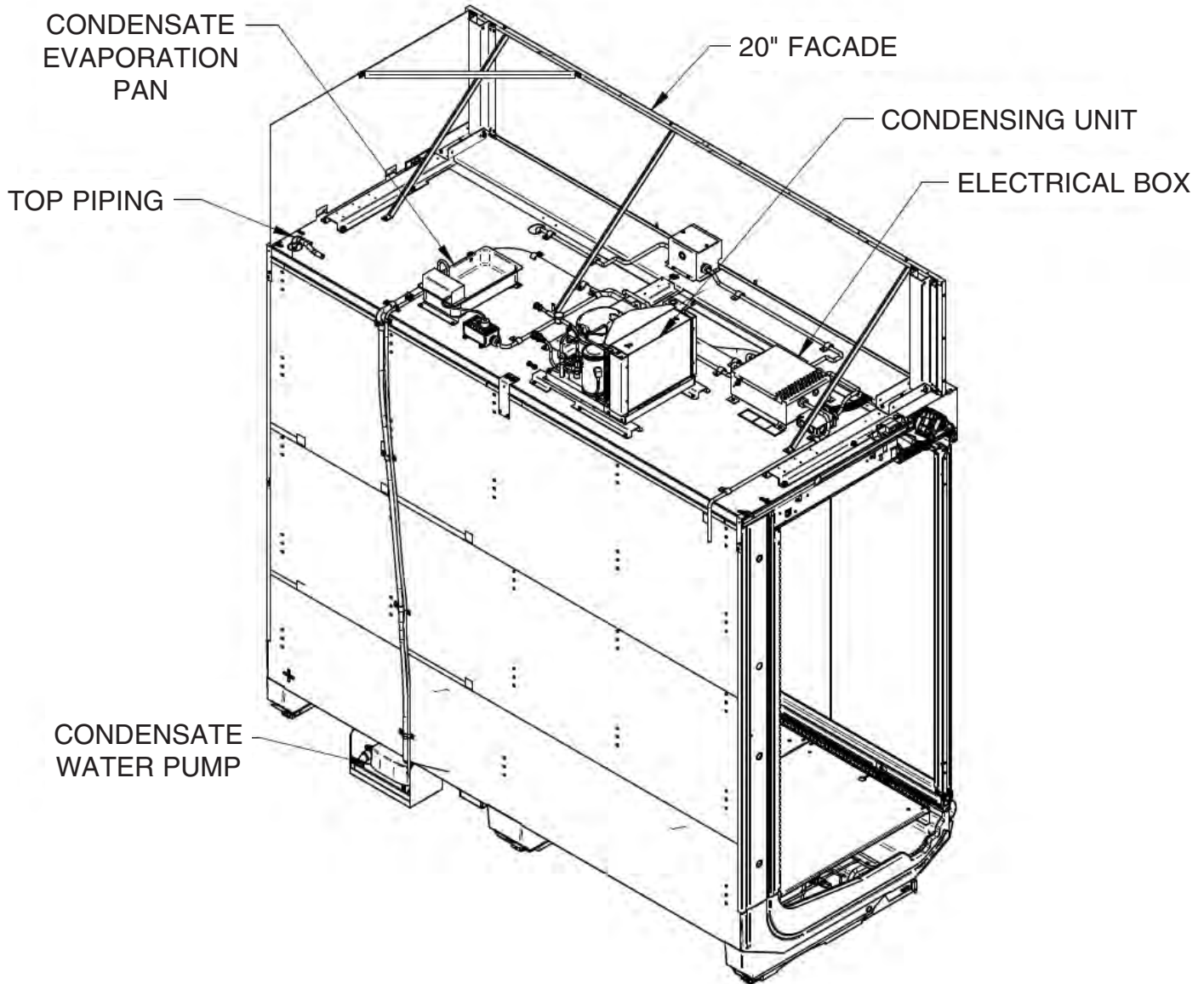

**FIELD-INSTALLED CONDENSING UNIT  
LOCATION (Water-cooled option)**

**COPELAND CONDENSING UNIT MOUNTING**

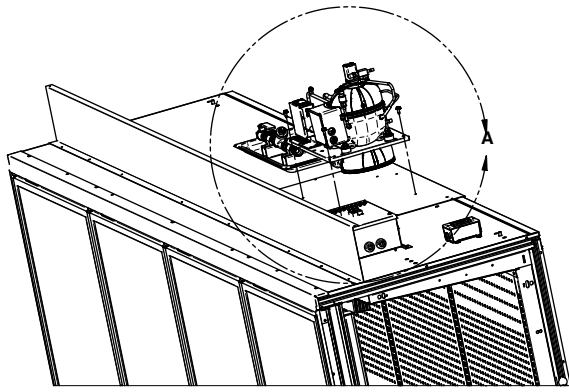

TOP ISO VIEW  
PARTS HIDDEN FOR CLARITY

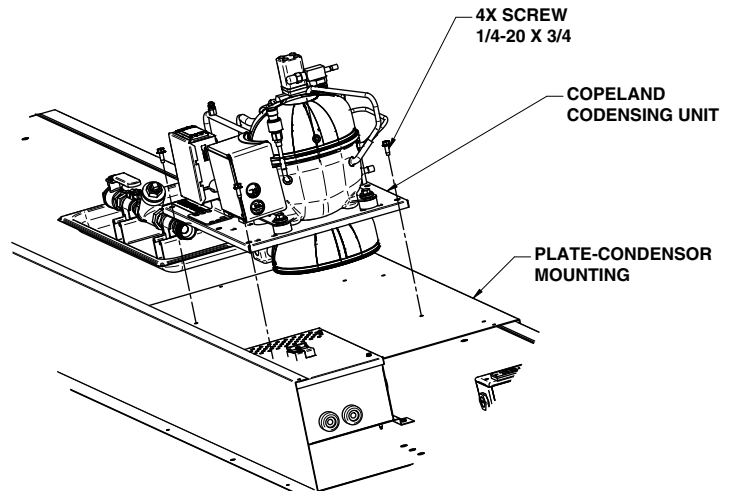

DETAIL A

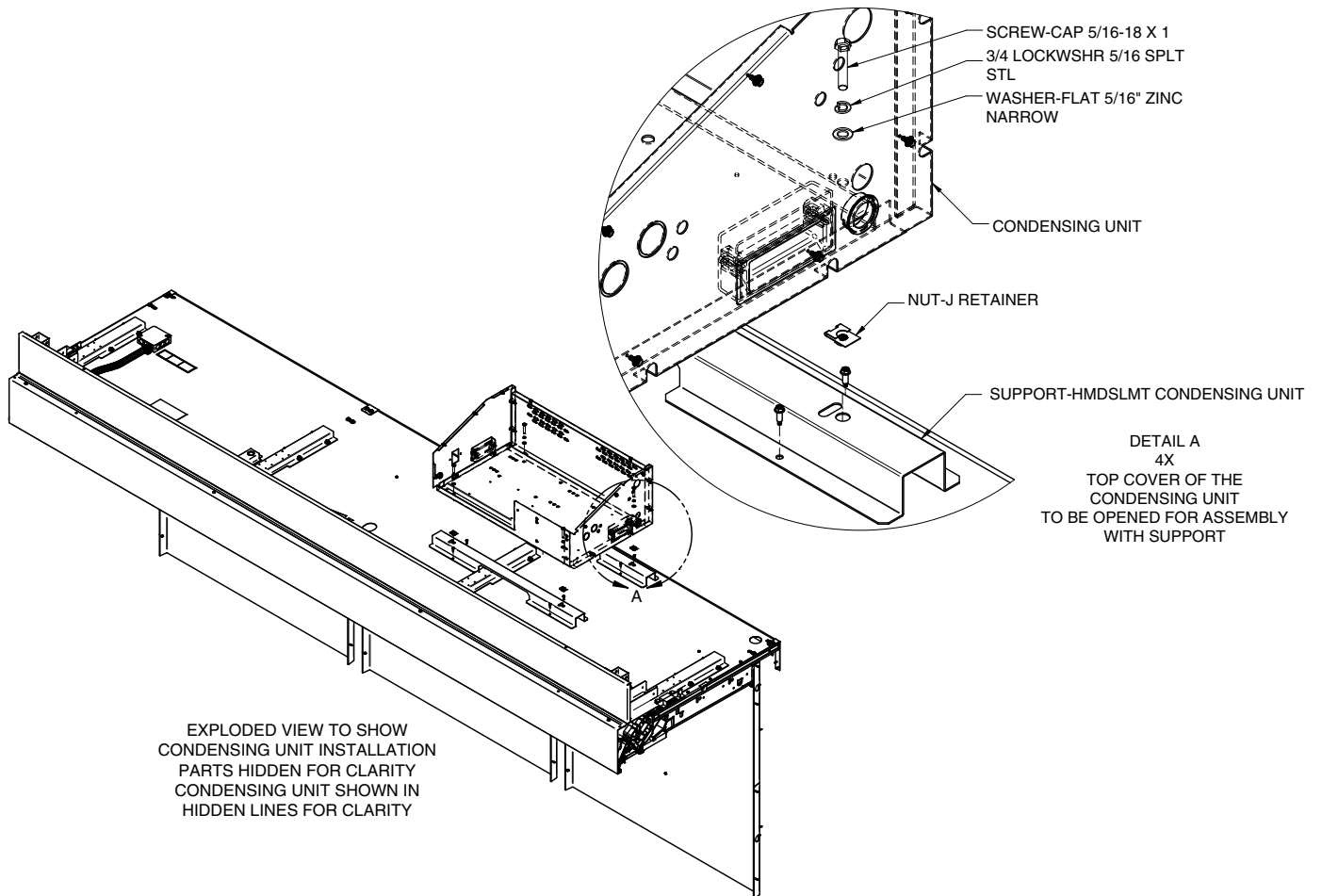

EXPLODED VIEW TO SHOW  
CONDENSING UNIT INSTALLATION  
PARTS HIDDEN FOR CLARITY  
CONDENSING UNIT SHOWN IN  
HIDDEN LINES FOR CLARITY

## ABOUT QUICK CONNECT COUPLINGS

Quick Connect fittings are provided on both the case inlet and outlet lines, and on Hussmann's Freedom Line condensing units. The case and condensing unit are pre-charged with the correct amount of refrigerant, and the lines are sealed. Connecting the Quick Connects together breaks the seals to connect the refrigeration lines of the unit to the case. The Quick Connects must be properly torqued to avoid refrigerant leaks.

## CONNECT LINES

Mount the suction line and liquid line to the condensing unit. When ready to connect, remove protector caps and plugs from the Quick Connect couplings.

If necessary, carefully wipe coupling seats and threaded surfaces with a clean cloth to prevent the inclusion of dirt or any foreign material in the system.

Lubricate male half diaphragm and synthetic rubber seal with refrigerant oil. Thread the coupling halves together by hand to ensure proper mating of threads. Use proper size wrenches (on coupling body hex and on union nut) and tighten until coupling bodies "bottom" or a definite resistance is felt.

### Step 1:

Apply refrigerant oil to the entire surface of diaphragm, o-ring and threaded area of male coupling assembly. The amount of lubricant used must cover all designated surfaces sufficiently. Ideal application is a small applicator brush saturated with lubricant and applied liberally.

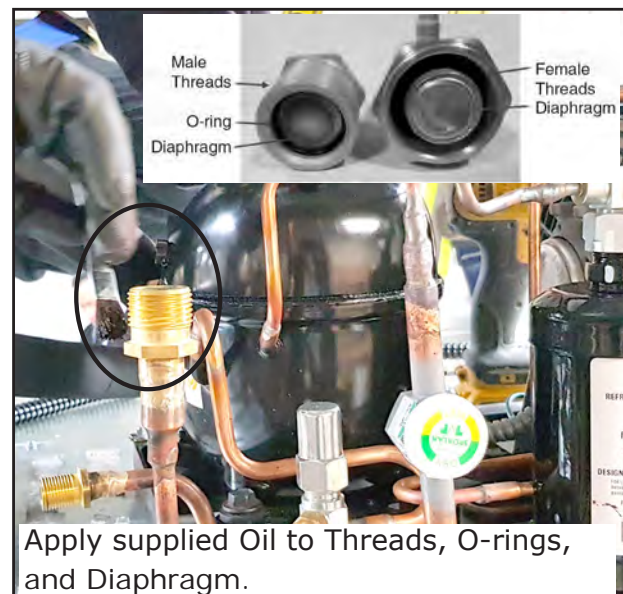
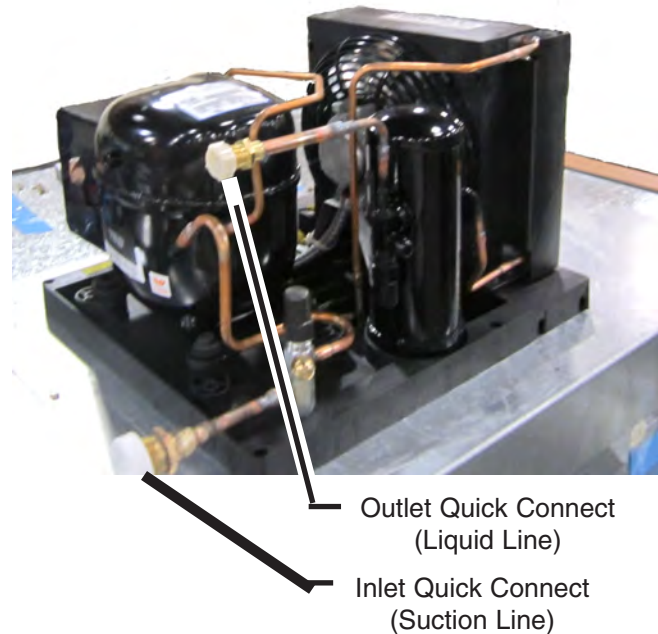

**Step 2:**

Ensure that the coupling halves are held in proper alignment with each other prior to starting the threads of the female coupling nut onto the male half.

The coupling end faces should be parallel with each other and visually in line with each other, this allows the female coupling nut to easily be threaded on by hand for the initial 2-3 rotations of the union nut. These initial rotations will bring the diaphragm in contact and a sharp increase in torque will be felt when they come into contact and start to pierce the diaphragms on each coupling half.

If the nut will not start by hand, adjust the position of the line set to ensure proper coupling alignment and eliminate/minimize all side load force on the coupling during assembly.

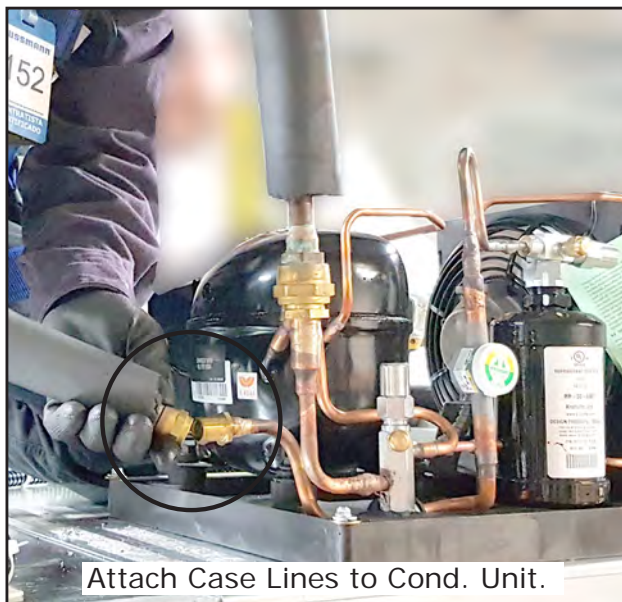

Attach Case Lines to Cond. Unit.

**Step 3:**

Using appropriate size wrenches, reference table below for the female coupling body and female union nut, tighten the female union nut, according to the torque specs below, while preventing rotation of the female body with respect to the male half. The nut should be tightened until a definite increase in resistance, metal to metal contact occurs, is felt (at this point, the nut will have covered most of the threads on the male body). It is important to ensure the male and female coupling bodies **DO NOT ROTATE** during any portion of the wrench installation.

Coupling	Hex Wrench Size
3/8 in. Male	3/4 in.
3/8 in. Female	13/16 in.
5/8 in. Male	1 1/16 in.
5/8 in. Female	1 5/16 in.

Coupling Size	Foot Pounds (Ft. Lbs.)
3/8 in.	10-12
5/8 in.	35-45

**⚠ CAUTION**

» Excessive ambient conditions may cause condensation and therefore sweating of doors. Facility operators should monitor doors and floor conditions to ensure safety of persons.

**Step 4:**

Using a permanent marker or scribe, mark a line lengthwise from the female coupling union nut to either the bulkhead or female coupling body. Then tighten an additional one (1) wrench flat (60°); refer to the marking on the union nut to confirm the rotation has occurred. The final rotation is necessary to ensure the formation of the leak-proof seal, between the male and female couplings.

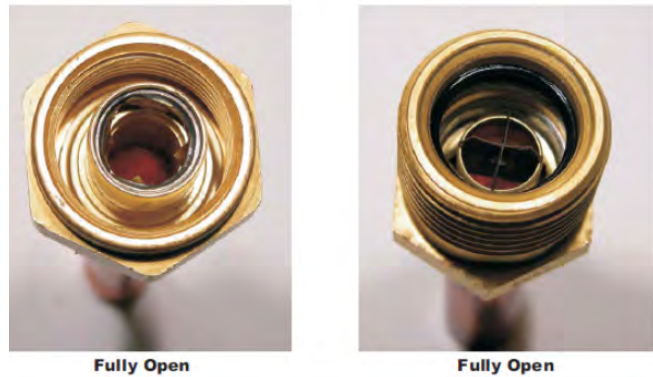

**CORRECTLY TIGHTENED COUPLING**

The swivel nut end contains one diaphragm in the center post. The male fitting contains the knife blades and its own diaphragm.

**IMPORTANT!**

Tighten swivel fitting until the fitting has significant resistance (fittings bottoming out). Apply ¼ turn past the resistance. Ensure no threads are visible.

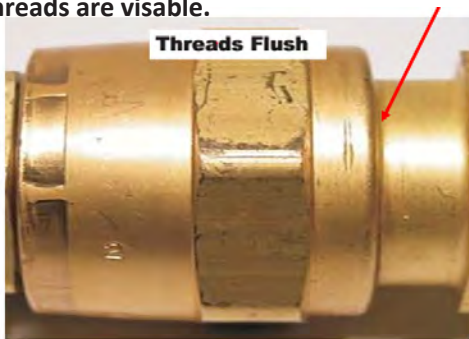

**INSULATE REFRIGERANT LINES**

Suction lines are insulated to prevent condensation; extra insulation is provided to cover the field connected tubing sections. These exposed sections must be covered with insulation. Check that all suction lines are adequately covered with insulation, as some insulation may have been dislodged during shipping and installation. Avoid locating the tubing above the electrical box to prevent condensation from dripping onto electrical components.

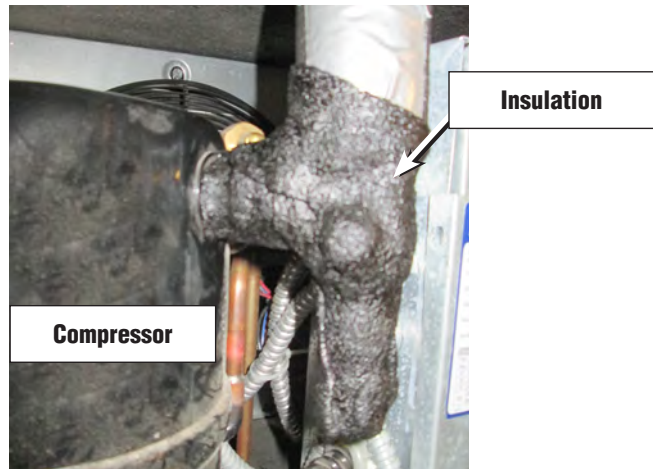

### FIELD WIRING

All wiring must be in compliance with NEC and local codes. Field wiring must be sized for component amperes stamped on the serial plate. Actual ampere draw may be less than specified. Field wiring lands on the line side of the service disconnect.

Terminal blocks are used for field connection of the 120V single phase and 208/230V single phase power supply. The terminal blocks are located inside the electrical box on top of the case. The wiring diagram and circuit requirements are provided on the Technical

Data Sheets provided with the case and condensing unit. A disconnect switch may be provided as an option. When this switch is off, some electrical terminals in the case wireway may be energized. The wiring connection for the condensing unit is provided with 5-ft leads and 1/4-inch terminals. The conduit must be connected to the condensing unit electrical box, and the leads are connected to the condensing unit input terminals. The heated condensate pan, if provided, is plugged into the GFCI receptacle at the top of the case.

### CONTROLLER DISPLAY

Insert the display from the front into the opening provided in the facade.

#### IMPORTANT:

Refer to specific wiring diagrams or condensing unit data sheets. Field wiring lands on the line side of the service disconnect.

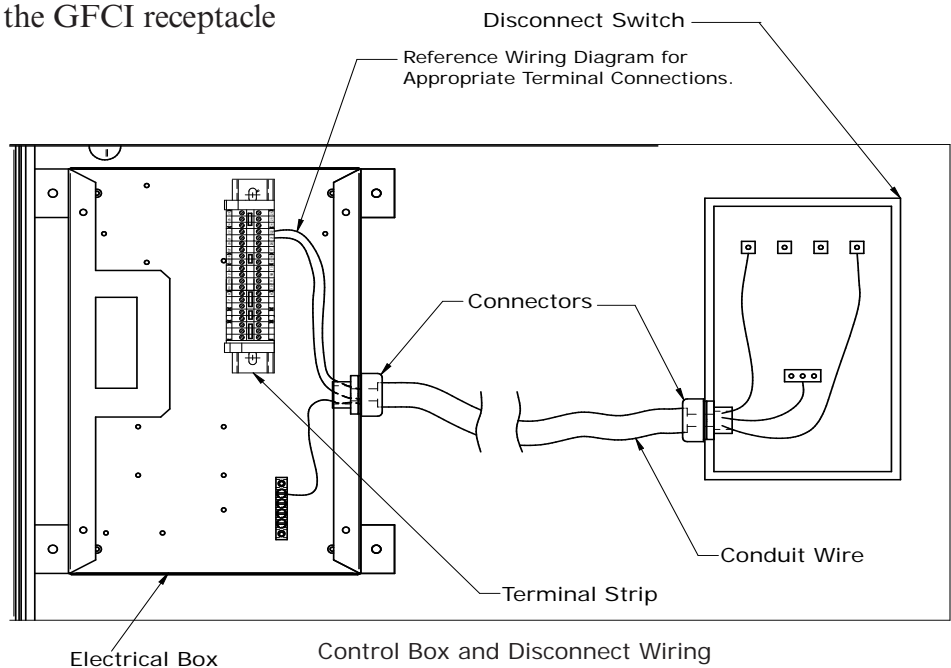
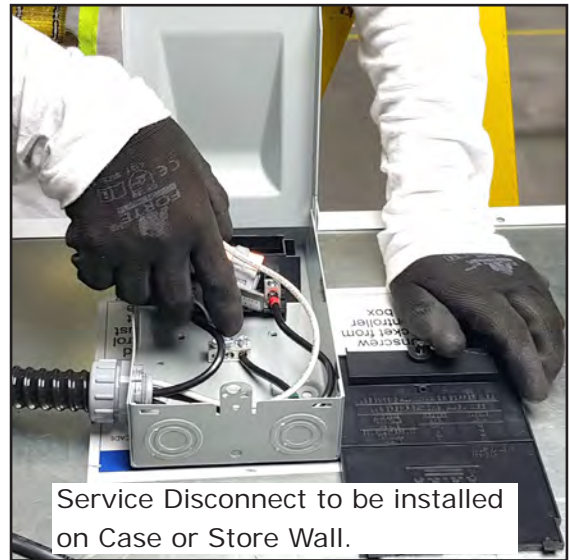

Installation of Defrost Water Drain Line to Case Condensate Pump  
(Viewed from Front of Case with Shipping Brace Removed)

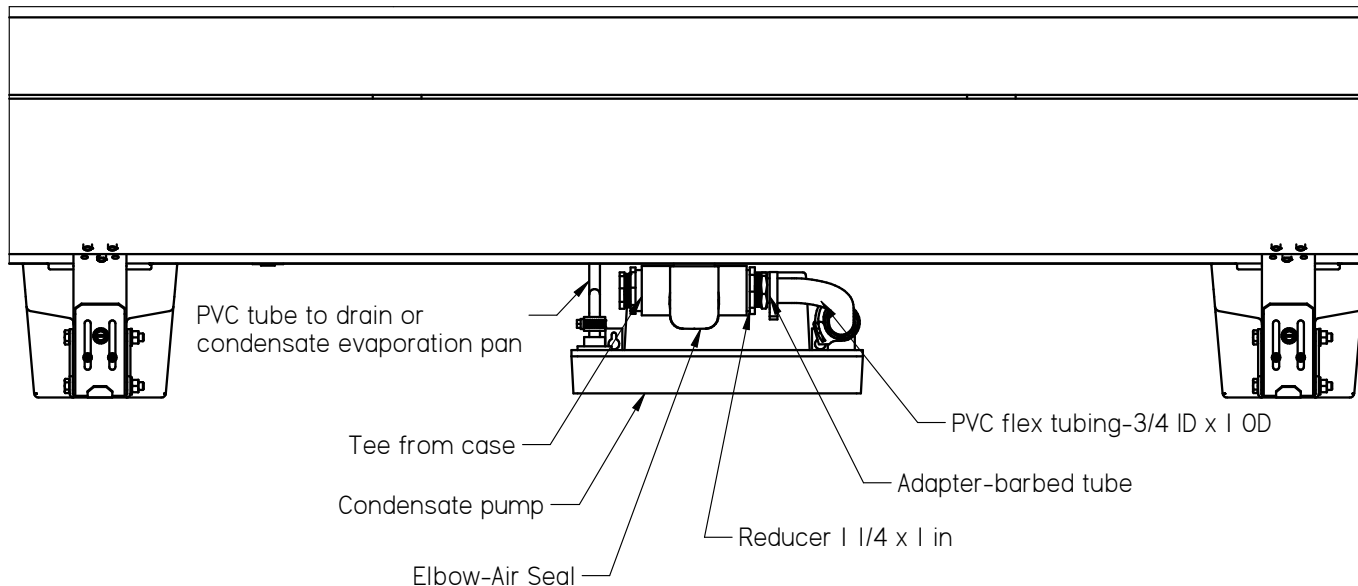

INCORRECT

Tube must be fully seated on barbed fitting.



CORRECT

**⚠ CAUTION**

» Blocked drain lines will cause water to back up in the case and spill onto the floor, causing a slip hazard.

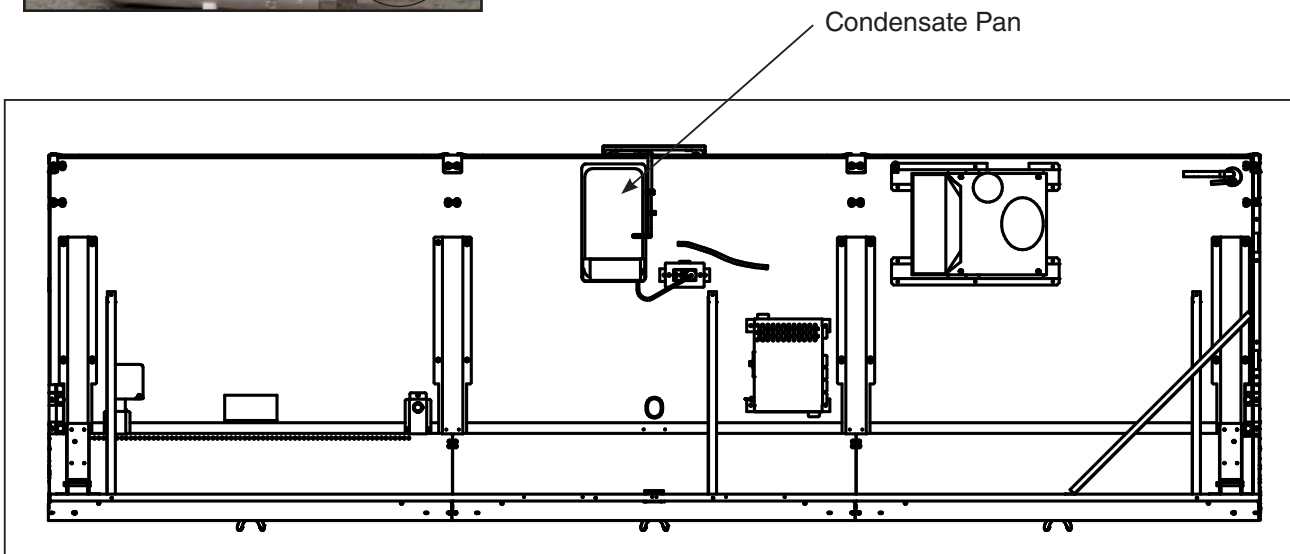

### CONDENSATE WATER PAN AND PUMP (OPTIONAL)

Rear mount condensate pump shown. Use this option only when rear of case is accessible after installation.

The bottom drain for defrost water from the evaporator coil is connected to an evacuation pump which uses 3/8-inch plastic drain tubing to pump the water to the condensate pan on top of the case. The tubing should be inspected through its entire length to ensure that it has not been cut, kinked, obstructed, or damaged during shipping and installation.

The tees and elbows in the illustrations are to be fitted in the foam tube bottom of the merchandiser. The pump's tubing is then routed behind the case to the condensate pan on top of the case.

Item Number	Title	Quantity
1	DEFROST WATER PUMP CP-22LP	1
2	ELBOW-90 PVC .500 SOCKET X .750 FEMALE THREADED	1
3	FITTING-.750 MALE THREADED BARBED TUBE ADAPTER	1
4	FITTING-1" MALE THREADED BARBED TUBE ADAPTER	1
5	BUSHING-REDUCER 1 1/4 X 1 IN	2
6	PLUG- 1 IN THREADED	1
7	TEE-1.250 SLP X SLP X SLP	1
8	ELBOW- AIR SEAL INSIGHT	1
9	TUBING-CLR VINYL 3/8ID X 1/16WALL	12.0 LF
10	TUBING-PVC CLEAR FLEX ID .750 X 1.000 OD	36.0 INCHES
11	CLAMP-7/8 NYLON	2
12	CLIP-JIFFY 3/8 (5/8 TUBE)	4
13	SCREW-SM 8-18X5/8 PHIL HX HD	7
14	TUBE-.375 X .028W CONDENSATE PAN	1
15	CLIFF JIFFY FOR 3/8 TUBE	1
16	CLAMP-HOSE 1/4 TO 5/8	2
17	BRACKET SUPPORT CONDENSATE PUMP	1

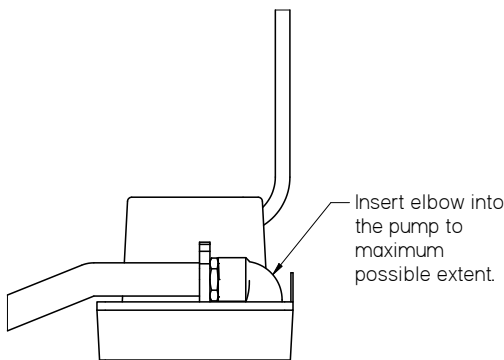
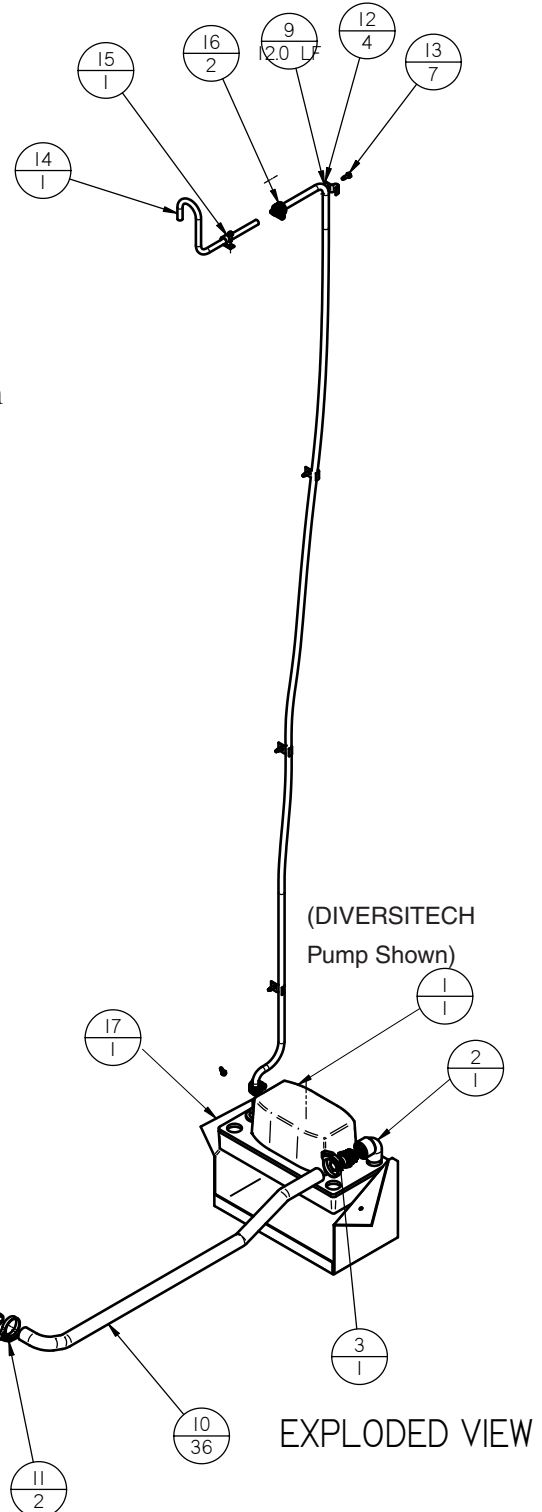

PARTIAL RIGHT SIDE VIEW  
PARTS HIDDEN FOR CLARITY

**CONDENSATE WATER PAN AND PUMP**

Underneath Case Option 1

(Not for use with ultra-low base heights)

Item Number	Title	Quantity
1	DEFROST WATER PUMP CP-22LP	1
2	ELBOW-90 PVC .500 SOCKET X .750 FEMALE THREADED	1
3	FITTING-.750 MALE THREADED BARBED TUBE ADAPTER	1
4	FITTING-1" MALE THREADED BARBED TUBE ADAPTER	1
5	BUSHING-REDUCER 1/4 X 1/2 IN	2
6	PLUG- 1 IN THREADED	1
7	TEE-1.250 SLP X SLP X SLP	1
8	ELBOW- AIR SEAL INSIGHT	1
9	TUBING-CLR VINYL 3/8ID X 1/16WALL	8.5 LF
10	TUBING-PVC CLEAR FLEX ID .750 X 1.000 OD	7.2 INCHES
11	CLAMP-7/8 NYLON	2
12	CLIP-JIFFY 3/8 (5/8 TUBE)	4
13	SCREW-SM 8-18X5/8 PHIL HX HD	5
14	TUBE-.375OD X .032WALL CONDENSATE PAN	1
15	CLIFF JIFFY FOR 3/8 TUBE	1
16	CLAMP-HOSE 1/4 TO 5/8	2

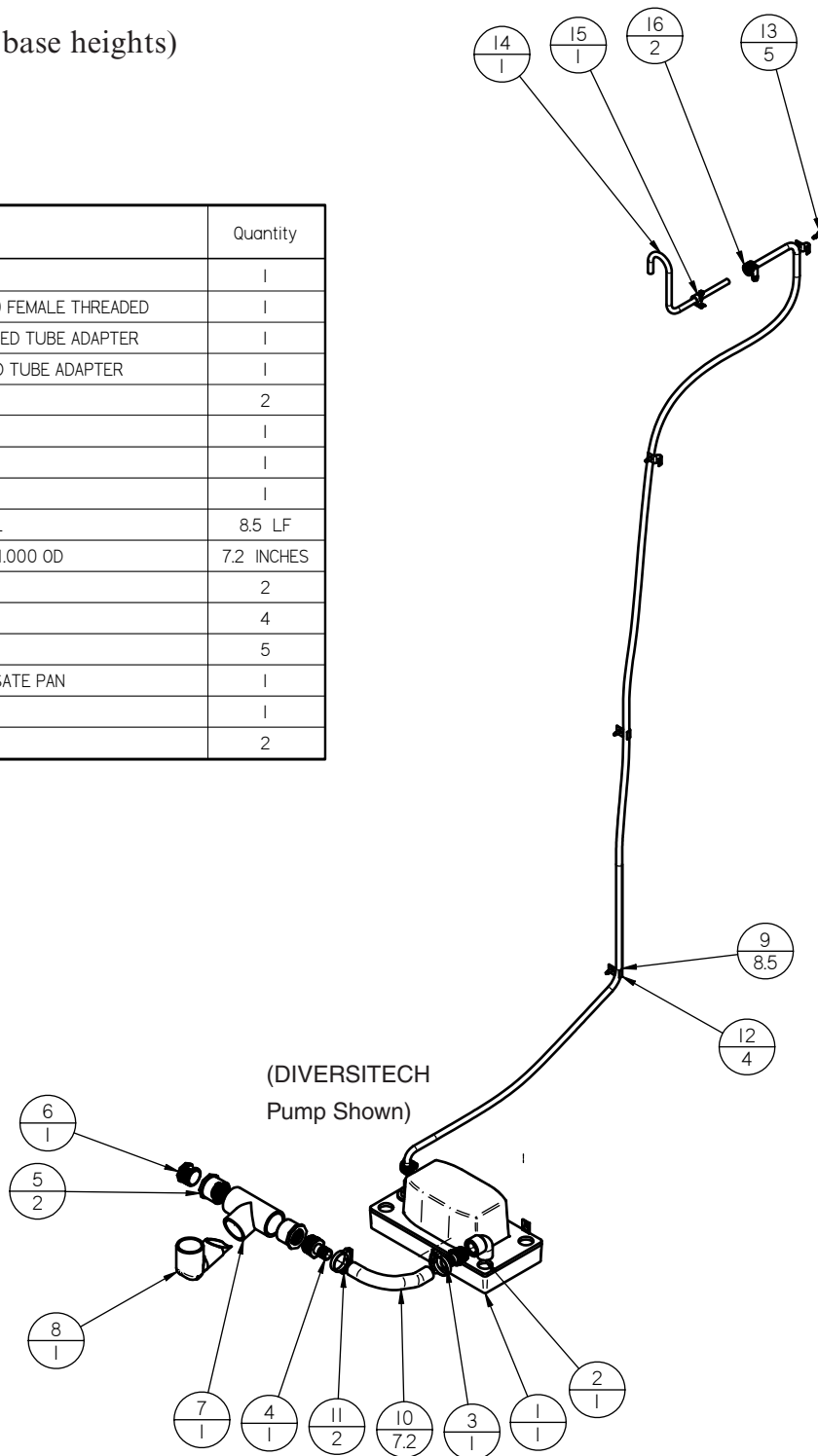

EXPLODED VIEW

### CONDENSATE WATER PAN AND PUMP

Underneath Case Option 2

(For all Insight cases - Extended splashguard required with ultra-low base heights)

PART LIST - ASSEMBLY			
ITEM	PART NUMBER	TITLE	QTY
1	0067461	CLIP-JIFFY FOR 3/4 OD	2
2*	0482328000	TAPE-VHB IX72Y .025THK	0.25 meters
3	0365202002	CONDUIT PVC X-FLEX .375	SEE HARNESS ASSY
4	0534121	SCREW-SM 8-18X5/8 PHIL HX HD	12
5	3107766	PUMP ASSY-BLUE DIAMOND ULTRA LOW	1
6	0535768	ELBOW- AIR SEAL INSIGHT	1
7	3108090	HOSE-BRAIDED 0.50 ID	1
8	0386604000	BUSHING-REDUCER 1 1/4 X 1	2
9	3105145	ADAPTER-0.50 X 0.75-14 MPT	1
10	0393539001	TEE-1.250 SLP X SLP X SLP	1
11	3113877	TUBE-CONDENSATE PAN RFLNS,RFMNS	1
12	0346763000	CLIP-JIFFY FOR 1/2 TUBE	10
13	3128079	HARNESS-WIRE ASSY INSIGHT	1
14	0386605000	PLUG-I THREADED	1
15	0529081	CLAMP-HOSE 1/4 TO 5/8	1
16	3105144	BUSHING-I-11.5 MPT X 0.75-14 FPT	1
17*	0116056	TIE-EYELET STRAP	2

ITEMS WITH \* ARE NOT SHOWN IN THIS VIEW

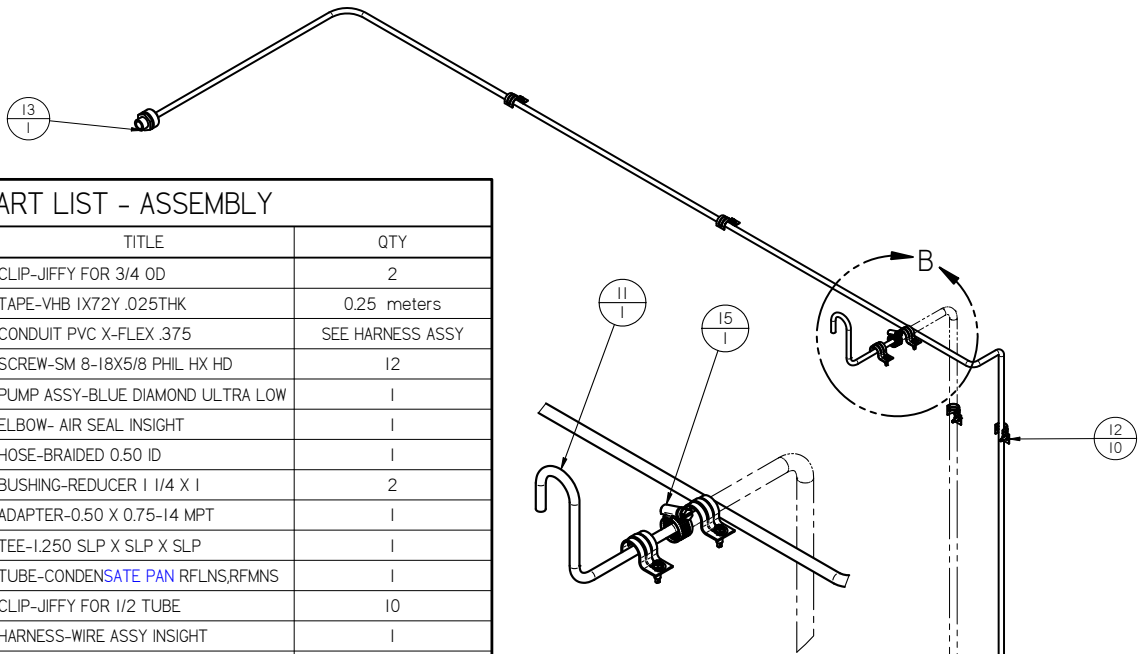

(K) DETAIL B

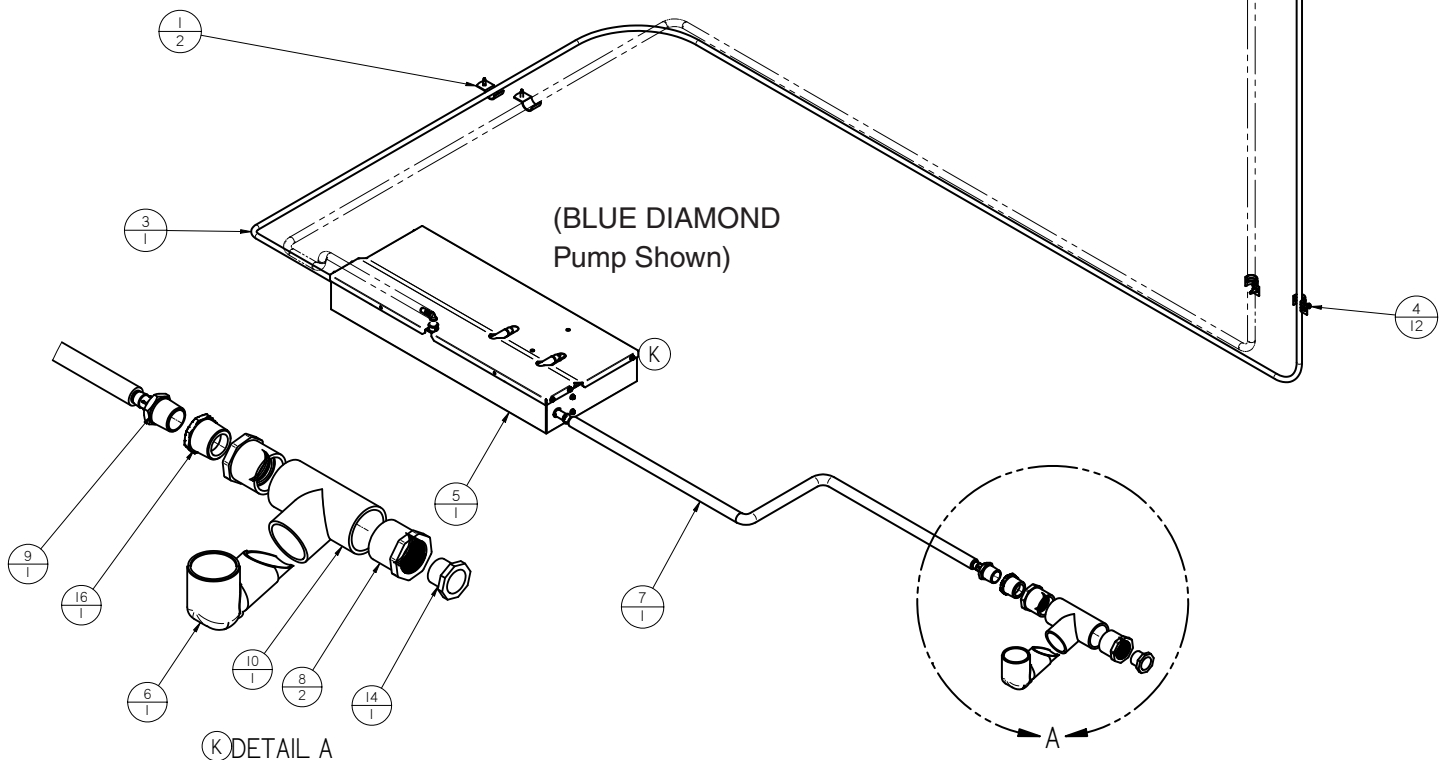

(K) DETAIL A

Field connection of electrical power shall be supplied as two circuits: Circuit #1 powers the case fans, case lighting, and (optional) condensate pump; Circuit #2 powers the condensing unit, controller, and (optional) condensate evaporator pan. Field connection for Circuit #1 shall be made inside the canopy electrical raceway, and field connection for Circuit #2 shall be made inside the electrical enclosure on top of the case. The wiring diagram and circuit requirements are provided on the Technical Data Sheets provided with the case and condensing unit.

**ALWAYS CHECK THE SERIAL PLATE FOR COMPONENT AMPERES.**

Electric Defrost is standard for low temperature merchandisers and requires temperature termination. Off Time Defrost is standard for medium temperature merchandisers and is temperature terminated.

**Following NEC and local codes is the responsibility of the electrical contractor.**

## ELECTRICAL CONNECTIONS

All wiring must be in compliance with NEC and local codes. All electrical connections are to be made in the electrical enclosure box located on top of case.

### **⚠ WARNING**

» Terminal block NOT for case-to-case wire connection.

## IDENTIFICATION OF WIRING

Leads for all electrical circuits are identified by colored plastic bands. These bands correspond to the color code sticker (shown below) located inside the merchandiser wireway. Refer to the Electrical diagrams are shipped with case Data Sheet.

### WIRING COLOR CODE

Leads for all electrical circuits are identified by a colored plastic band: neutral wire for each circuit has either White insulation or a White plastic sleeve in addition to the color band.

**PINK ..... REFRIG. THERMOSTAT LOW TEMP.**

**LIGHT BLUE. REFRIG. THERMOSTAT NORM TEMP.**

**DARK BLUE. DEFROST TERM. THERMOSTAT**

**PURPLE ..... ANTI-SWEAT HEATERS**

**BROWN ..... FAN MOTORS**

**GREEN\* ..... GROUND**

**ORANGE OR**

**TAN ..... LIGHTS**

**MAROON ... RECEPTACLES**

**YELLOW\* ... DEFROST HEATERS, 120V**

**RED\* ..... DEFROST HEATERS, 208V**

**\*EITHER COLORED SLEEVE OR COLORED INSULATION**

**ELECTRICIAN NOTE: Use copper conductor wire only.**

**CASE MUST BE GROUNDED**

**THESE ARE MARKER COLORS WIRES MAY VARY.**

### INSTALLATION OF WATER LINES (For water-cooled condensing units)

3/4" male National Pipe Thread (NPT) connections are provided at the top of the case for water line connections. Hoses are marked with inlet and outlet. Optional flow control valves may be supplied.

Refer to the technical data sheets for flowrate, pressure drop, and heat of rejection. Water supply must have adequate corrosion inhibitors and freeze protection. Refer to Document 0525699 for propylene glycol guidelines.

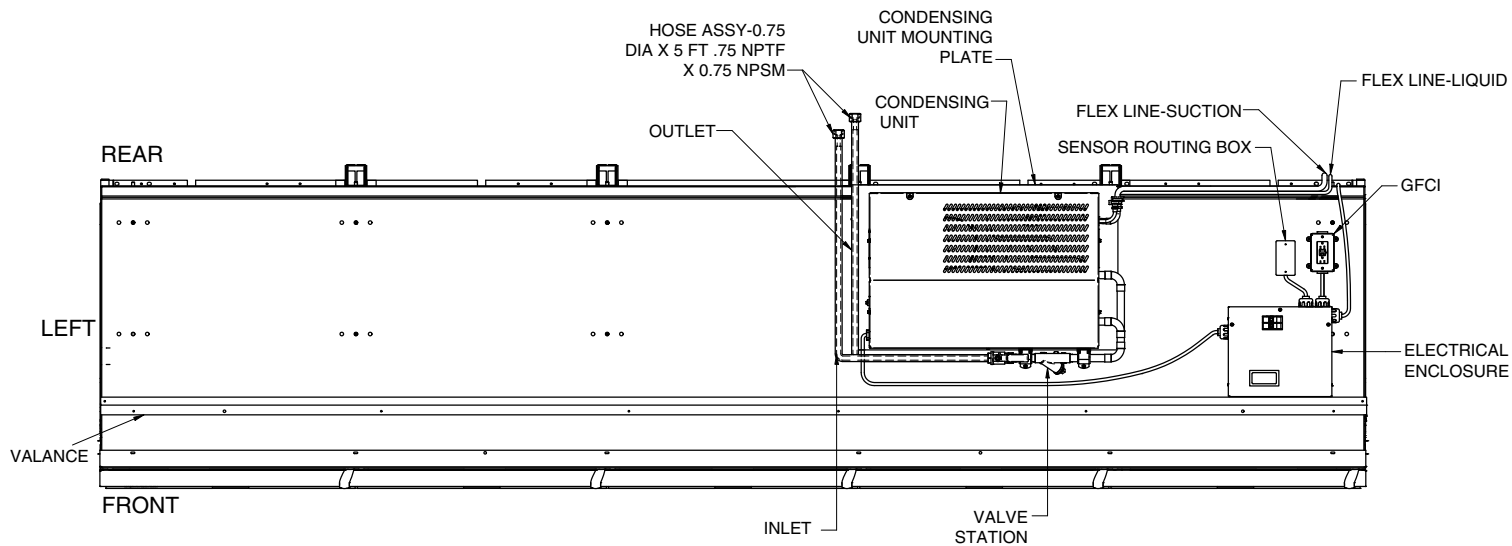

Hussmann recommends using DOWFROST™ inhibited propylene glycol.

Pre-diluted solutions (35% inhibited propylene glycol) of DOWFROST™ are available from Dow. The ingredients in DOWFROST™ have been approved by the FDA and are listed as chemically acceptable by USDA.

The Dow Chemical Company  
Midland, MI 48674  
1-800-447-4369  
www.dow.com

Requirements on system fluid:  
Pre-mixed 35% inhibited propylene glycol

Typical Fluid Properties  
Solution Composition is 35% inhibited propylene glycol by weight

pH of Solution 8.0 – 10.0  
Specific Gravity (at 60°F) 1.033  
Viscosity (at 20°F) 14.2 cP  
Boiling Point of Solution 217°F  
Freezing Point of Solution 2°F  
Refractive Index (at 72°F) 1.3733

#### System Balancing

Balancing may be required to provide adequate coolant flow to each circuit in order to maintain the required waterflow. Balancing is achieved through the setting of balance valves located throughout the system piping.

The installation contractor must consult and be familiar with the manufacturer's Material Safety Data Sheets (MSDS) before handling any secondary fluid. The MSDS contains proper disposal and safety methods.

#### Automatic Balancing Valves

Case may be equipped with automatic balancing valves. The case will maintain the correct flow rate. The cooling system pressure must be between 5 to 30 psid for proper operation of the automatic balancing valves.

#### PRE-INSTALLATION SYSTEM CLEANING

Dow recommends the new piping system be cleaned using a 1-2% solution of trisodium phosphate (TSP), or equivalent cleaner and distilled or deionized water to remove grease, mill scale, or other residues from construction.

Repeat this process if necessary until the drained solution is clear and free from visible debris. The system should then be drained and flushed again using distilled or deionized water.

Hussmann only recommends distilled or deionized water for system flushing with 2% TSP. Dry nitrogen can be used for the initial pressure test, (60 to 75 psi), hold for three hours.

## NOTICE

Use only distilled or de-ionized water for flushing with 2 percent TSP. Use a pre-mixed inhibited glycol solution. If the mixing is to be done on site, use only distilled or de-ionized water. Do not use tap water.

## ELECTRONIC CONTROLLER

Safety controls are installed on Freedom condensing units to protect the compressor from various errors or adverse conditions:

- High pressure safety control
- Low pressure safety control
- Compressor discharge temperature sensor

### Air cooled condensing units with Electronic Unit Controller:

On condensing units that are equipped with the Emerson Electronic Unit Controller, the pressure controls and discharge line alarm are incorporated into the controller on the condensing unit.

The high pressure cut-out is a non-adjustable pressure switch with a cut-out of 440 psig. The low pressure control and compressor discharge temperature setpoint are programmed into the electronic unit controller on the condensing unit. The compressor discharge temperature is set to cut out at 225°F. The low pressure control is set to cut out at 15 psig, and cut in at 25 psig. For low temp units, the control is set to cut out at 5 psig and cut in at 15 psig.

### Air cooled condensing units without Electronic Unit Controller:

On Freedom cases that have condensing units that are not equipped with the Emerson Electronic Unit Controller, including water cooled units, the high and low pressure safety controls are connected to terminals 18 and 19 of the XR75 case controller. Air cooled unit have a discharge line sensor, which is connected to terminals 21 and 23. The case controller parameters are set at the factory to incorporate the controls. The pressure controls are not adjustable. The discharge safety is set in the case controller to cut out at 230°F.

These controls must be connected after installation of the condensing unit. Harnesses are provided and marked to show the connections (see wiring diagram on next page).

The parameters in the Dixell XR75 are set up in the factory to enable the pressure control functionality. The parameters affecting this control are shown in the diagram below.

Parameter	Description	Value
P4P	Fourth probe presence	yes
AP2	Probe selection for condenser temperature alarm	P4
AU2	Condenser high temperature alarm	220
AH2	Differ for condenser temperature alarm recovery	45
Ad2	Condenser temperature alarm delay	15
dA2	Delay of condenser temperature alarm at startup	0
AC2	Compressor off for condenser high temperature alarm	yes
tbA	Alarm relay switch off by pushing a key	yes
i1F	Digital input 1 configuration	dor
i2P	Digital input 2 polarity	OP
i2F	Digital input 2 configuration	PAL
did	Digital input 2 alarm delay	30
nPS	Number of activations of pressure switch	3

**ALARM SIGNALS DISPLAYED:****Temperature alarm:**

Probe alarm

High pressure or low pressure alarm:

High discharge temperature (condenser alarm):

**Possible causes of high/low pressure alarm:**

- Excessive refrigerant
- Lack of refrigerant
- Lack of air flow into the condenser
- Superheat too high
- High temperatures at startup
- Service valves closed

High and low pressure alarm will show up as the same alarm signal on the controller display. If this alarm condition exists, the unit must be serviced by a qualified technician.

Discharge temperature alarm is an indication that the condenser is blocked and needs to be cleaned, or remove blockage (such as balloons, paper, etc). Refer to supplemental manuals and wiring diagrams for special options and other controllers.

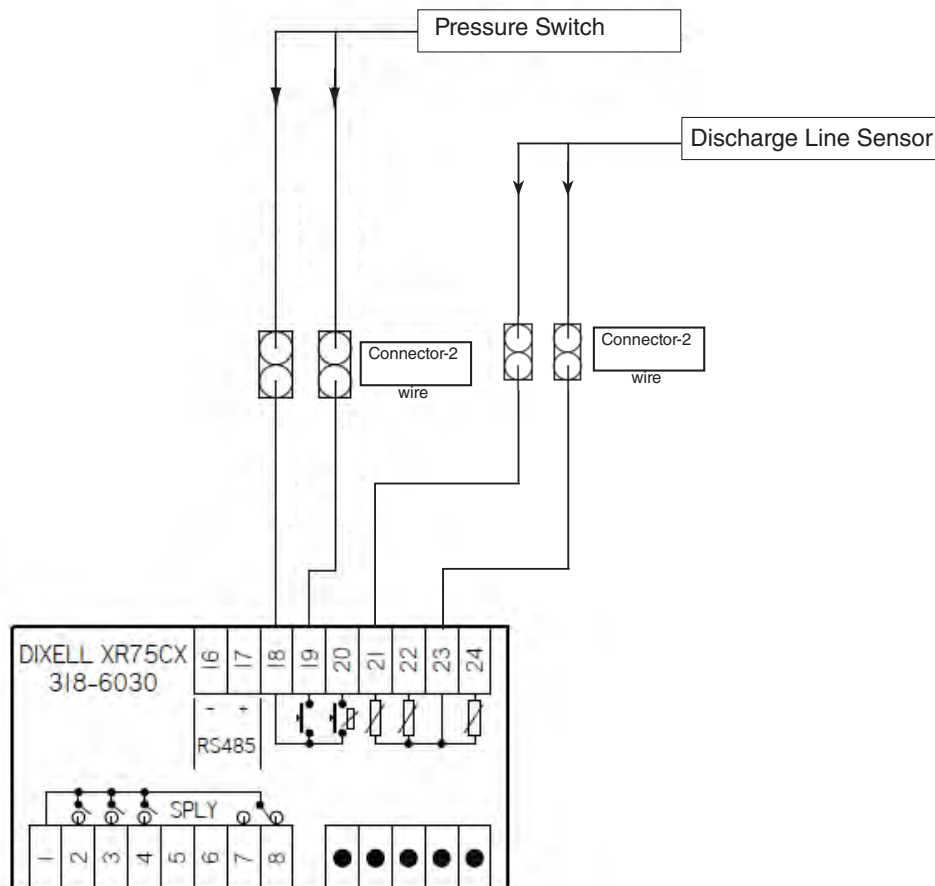

## CONTROLLER

### 1.1. General Warning

Please read the following safety precautions and warnings before using this manual:

**CAUTION!**



- *This manual is part of the product and should be kept near the device for easy and quick reference.*
- *The device should not be used for purposes different from those described in this manual. It cannot be used as a safety device.*
- *Check the application limits before proceeding.*

**SAFETY PRECAUTIONS AND WARNINGS!**



- *Check that the supply voltage is correct before connecting the device.*
- *Do not expose to water or moisture: use the controller only within the operating limits and avoid sudden temperature changes with high atmospheric humidity to prevent condensation from forming.*
- *Warning! Disconnect all electrical connections before performing any kind of maintenance.*
- *Fit the probe where it is not accessible by the end user. The device must not be opened.*
- *In case of failure or faulty operation, send the device back to the distributor or to Retail Solutions (see address) with a detailed description of the fault.*
- *Verify the maximum current that can be applied to each relay (see Section 15, Specifications).*
- *Ensure that the wires for probes, loads, and the power supply are separated and far enough from each other without crossing or intertwining.*
- *In case of applications in industrial environments, the use of main filters (our mod. FT1) in parallel with inductive loads could be useful.*

### 2.1. General Description

Model XR75CX (32 mm x 74 mm) is a microprocessor based controller, suitable for applications on medium or low temperature ventilated refrigeration units. It has four (4) relay outputs to control compressor, fan, and defrost, which can be either electrical or reverse cycle (hot gas) and light (configurable). It can have a Real Time Clock (RTC) that allows programming of up to six (6) daily defrost cycles, divided into holidays and workdays. A “Day and Night” function with two different setpoints is fitted for energy saving.

It can also have up to four (4) NTC or PT1000 probe inputs: the first one for temperature control, the second one located on the evaporator to control the defrost termination temperature and to manage the fan. One of the two (2) digital inputs can operate as a third temperature probe. The fourth probe is used to signal the condenser temperature alarm or to display a temperature value.

The RS-485 serial output enables the unit to be connected to a network line that is MODBUS-RTU compatible, such as the monitoring units of X-WEB family. The Hot Key receptacle allows the controller to be programmed by means of the Hot Key programming keyboard.

The controller is fully configurable through special parameters that can be easily programmed through the keyboard.

### 2.2. Ordering Code

Device Name	Dixell Code	Emerson Code
XR75CX - 110VAC	XR75CX-4C6F3B X0LG3OEUB4NA-000	318-6030
XR75CX - 230VAC	XR75CX-5C6F3B - X0LG3OEUB5NA-000	318-6031

*Table 2-1 - Product Ordering Code*

Reprinted with permission from Emerson™ Climate Technologies  
download XR75CX manual for more details or contact your Hussmann Representative.

## 3 Controlling Loads

### 3.1. Compressor

The regulation is performed according to the temperature measured by the thermostat probe with a positive differential from the setpoint: if the temperature increases and reaches setpoint plus the differential, the compressor is started and then turned OFF when the temperature reaches the setpoint value again. In case of a fault in the thermostat probe, the start and stop of the compressor are timed through parameters **Con** and **CoF**.

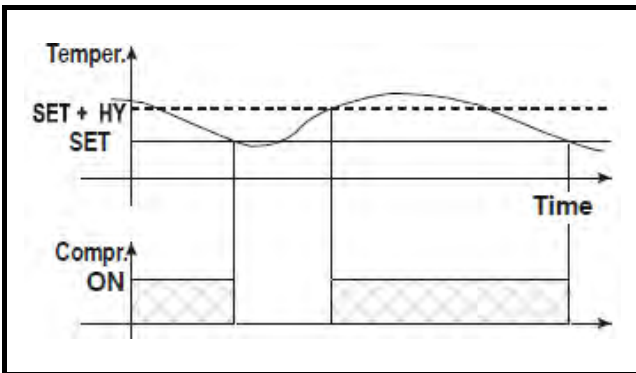

Figure 3-1 - Compressor Temperature Regulation

### 3.2. Defrost

Two defrost modes are available through the **tdF** parameter: defrost through electrical heater (**tdF=EL**) and hot gas defrost (**tdF=in**).

The defrost interval depends on the presence of the RTC (optional). If the RTC is present, it is controlled by means of parameter **EdF**:

- with **EdF=in** the defrost is made every **IdF** time (the standard method for the controller without RTC)
- with **EdF=rtC**, the defrost is made in real time depending on the hours set in the parameters.  
**Ld1..Ld6** on workdays and in **Sd1...Sd6** in holidays

Other parameters are used to control defrost cycles: its maximum duration (**MdF**) and two defrost modes: timed or controlled by the evaporator's probe (**P2P**).

At the end of defrost dripping time is started, its duration is set in the **Fdt** parameter. With **Fdt=0**, the dripping time is disabled.

### 3.3. Control of Evaporator Fans

The fan control mode is selected by means of the **Fnc** parameter:

- **Fnc = C\_n**: fans will switch ON and OFF with the compressor and not run during defrost.
- **Fnc = O\_n**: fans will run even if the compressor is OFF, and not run during defrost; after defrost, there is a timed fan delay allowing for drip time, set by means of the **Fnd** parameter.
- **Fnc = C\_y**: fans will switch ON and OFF with the compressor and run during defrost.
- **Fnc = O\_y**: fans will run continuously during defrost also.

An additional parameter called **FSt** provides the setting of temperature, detected by the evaporator probe, above which the fans are always OFF. This is used to make sure of air circulation only if this temperature is lower than set in **FSt**.

#### 3.3.1. Forced Activation of Fans

Managed by the **FCt** parameter, this function is designed to avoid short cycles of fans that could occur when the controller is switched ON or after a defrost, when the room air warms the evaporator. Functioning: if the difference of temperature between the evaporator and the room probes is more than the value of the **FCt** parameter, the fans are switched ON. When **FCt = 0**, the function is disabled.

#### 3.3.2. Cyclical Activation of the Fans With Compressor Off

When **Fnc = C-n** or **C-y** (fans in parallel to the compressor), by means of the **Fon** and **FoF** parameters the fans can carry out ON and OFF cycles even if the compressor is switched OFF. When the compressor is stopped the fans continue working for the **Fon** time. When **Fon = 0**, the fans always remain OFF when the compressor is OFF.

## 3.4. Light Relay Configuration (PAR oA3; TERM. 1-4)

The functioning of the auxiliary relay (terminals 1-4) can be set by the **oA3** parameter, according to the kind of application needed. Possible settings are as follows:

### 3.4.1. Light Relay

When **oA3 = Lig** the relay 1-4 operates as a light.

### 3.4.2. Auxiliary Relay – oA3=AUS

**a. Relay Activation By Digital Input 2 (oA3 = AUS, i2F = AUS)**

When **oA3 = AUS** and **i2F = AUS** the relay 1-4 is switched ON and OFF by the digital input.

#### **b. Auxiliary Thermostat**

An anti-condensing heater with the possibility of switching it ON and OFF with the keyboard.

#### **Parameters Involved**

- **ACH** The kind of regulation for the auxiliary relay:  
**Ht**: heating; **CL**: cooling
- **SAA** Setpoint for auxiliary relay
- **SHy** Differential for auxiliary relay
- **ArP** Probe for auxiliary relay
- **Sdd** Auxiliary output OFF during defrost

The functioning of the auxiliary relay can be set with these five parameters. The differential is given by the **SHy** parameter.



**NOTE:** Set **oA3 = AUS** and **ArP = nP** (no probe for auxiliary output). In this case the relay 1-4 can be activated only by the digital input with **i1F** or **i2F = AUS**.

### 3.4.3. On/Off Relay – oA3=onF

In this case the relay is activated when the controller is turned ON and de-activated when the controller is turned OFF.

### 3.4.4. Neutral Zone Regulation

When **oA3 = db** the relay 1-4 can control a heater element to perform a neutral zone action.

**oA3** cut in = **SEt-Hy**

### 3.4.5. Alarm Relay

When **oA3 = ALr** relay 1-4 operates as an alarm relay. It is activated every time an alarm occurs. Its status depends on the **tbA** parameter: if **tbA = y**, the relay is silenced by pressing any key. If **tbA = n**, the alarm relay remains ON until the alarm condition recovers.

### 3.4.6. Night Blind Management During Energy Saving Cycles

With **oA3 = HES**, the relay 1-4 operates to manage the night blind: the relay is powered when the energy saving cycle is activated, by digital input, front panel, or RTC (optional).

# 4 Front Panel Commands



Figure 4-1 - XR75CX Front Panel

## 4.1. Keys and Functions

Table 4-1 shows the keys that are found on the front panel of the XR75CX controller and their corresponding functions:

Key	Function
<b>SET</b>	Press to display target setpoint, to select a parameter in programming mode, or to confirm an operation
	Starts a manual defrost
	Press the UP arrow to see the MAX temperature, to browse the parameter codes in programming mode, or to increase the currently displayed temperature value.
	Press the DOWN arrow to see the MIN temperature, to browse the parameter codes in programming mode, or to decrease the currently displayed temperature value.

Table 4-1 - XR75CX Front Panel Keys and Functions

	Switches the device ON and OFF, if <b>onF = oFF</b>
	Switches the light ON and OFF, if <b>oA1 = Lig</b>
	Locks/Unlocks the keyboard
<b>SET</b> +	To enter programming mode
<b>SET</b> +	Returns to room temperature display

Table 4-1 - XR75CX Front Panel Keys and Functions

## 4.2. Use of LEDs

Each LED function is described in Table 4-2:

LED	Mode	Function
	ON	Compressor enabled
	Flashing	Anti-short cycle delay enabled
	ON	Defrost enabled
	Flashing	Drip time in progress
	ON	Fans enabled
	Flashing	Fans delay after defrost in progress.
	ON	An alarm is occurring
	ON	Continuous cycle is running
	ON	Energy saving enabled
	ON	Light ON
<b>AUX</b>	ON30	Auxiliary relay ON
<b>°C/°F</b>	ON	Measurement unit
<b>°C/°F</b>	Flashing	Programming phase

Table 4-2 - LEDs

## 5 Max and Min Temperature Memorization

---

### 5.1. How to See the MIN Temperature

1. Press and release the DOWN arrow key.
2. The **Lo** message will be displayed followed by the minimum temperature recorded.
3. By pressing the DOWN arrow key again or by waiting five seconds, the normal display will be restored.

### 5.2. How to See the MAX Temperature

1. Press and release the UP arrow key.
2. The **Hi** message will be displayed followed by the maximum temperature recorded.
3. By pressing the UP arrow key again or by waiting 5 seconds, the normal display will be restored.

### 5.3. How to Reset the Max and Min Temperature Recorded

1. Press and hold the SET key for more than 3 seconds, while the max or min temperature is displayed (**rSt** message will be displayed).
2. To confirm the operation, the **rSt** message starts blinking and the normal temperature will be displayed.

## 6 Main Functions

### 6.1. To Set the Current Time and Day (Only For Devices With RTC)

1. When the device is switched ON, it's necessary to program the time and day.
2. Enter the Pr1 programming menu, by pushing the SET + DOWN arrow keys for 3 seconds.
3. The **rtc** parameter is displayed. Push the SET key to enter the real time clock menu.
4. The **Hur** (hour) parameter is displayed.
5. Push the SET key and set current hour by the UP and DOWN arrow keys, then push SET to confirm the value.
6. Repeat the same operations on the **Min** (minutes) and **dAy** (day) parameters.

To exit: Push the SET + UP arrow keys or wait 15 seconds (without pushing any keys.)

### 6.2. How to See the Setpoint



1. Push and immediately release the SET key: the display will show the setpoint value.

2. Push and immediately release the SET key or wait for 5 seconds to display the probe value again.

### 6.3. How to Change the Setpoint

1. Push and hold the SET key for more than 2 seconds to change the setpoint value.
2. The value of the setpoint will be displayed and the °C or °F LED starts blinking.

3. To change the setpoint value push the UP or DOWN arrows within 10 seconds.
4. To memorize the new setpoint value, push the SET key again or wait 10 seconds.

### 6.4. How to Start a Manual Defrost



Push and hold the **DEF** key for more than 2 seconds and a manual defrost will start.

### 6.5. How to Change a Parameter Value

To change the parameter's value follow these steps:

1. Enter the Programming mode by pressing the SET + DOWN arrow keys for 3 seconds (the °C or °F LED starts blinking).
2. Select the required parameter. Press the SET key to display its value.
3. Use the the UP or DOWN arrows to change its value.
4. Press SET to store the new value and move to the next parameter.
5. To exit: Press SET + UP arrow or wait 15 seconds without pressing a key.



**NOTE:** The set value is stored even when the time-out expires and ends the procedure.

### 6.6. The Hidden Menu

The hidden menu includes all the parameters of the controller.

#### 6.6.1. How to Enter the Hidden Menu

1. Enter the Programming mode by pressing the SET + DOWN arrow keys for three (3) sec-

- onds (the °C or °F LED starts blinking).
2. Immediately release the keys, then push the SET + DOWN arrow keys again for more than seven (7) seconds. The **Pr2** label will be displayed immediately followed by the **Hy** parameter: *You are now in the Hidden Menu.*
  3. Select the required parameter.
  4. Press the SET key to display its value.
  5. Use the UP or DOWN arrows to change its value.
  6. Press SET to store the new value and move to the following parameter.

To exit: Press SET + UP arrow or wait 15 seconds without pressing a key.



**NOTE:** If no parameter is present in Pr1, after three (3) seconds the noP message is displayed. Keep the keys pressed until the Pr2 message is displayed.



**NOTE:** The set value is stored even when the time-out expires and ends the procedure.

### 6.6.2. How to Move a Parameter from the Hidden Menu and Vice Versa

Each parameter present in the Hidden Menu can be removed or put into “The First Level” (user level) by pressing SET + DOWN arrow. In the Hidden Menu when a parameter is present in the First Level, the decimal point is visible.

## 6.7. How to Assign a MODBUS Address

1. Follow steps 1 and 2 of **Section 6.6.1., How to Enter the Hidden Menu** to access the Hidden Menu.
2. Select the **Adr** parameter.
3. Press SET to select.
4. Choose the address number using the arrow keys and press SET again to save.

## 6.8. How to Lock the Keyboard

1. Keep the UP + DOWN arrow keys pressed for more than 3 seconds.
2. The **PoF** message will be displayed and the keyboard will be locked. At this point it will be possible to see the setpoint or the MAX or Min temperature stored only.
3. If a key is pressed for more than 3 seconds the **PoF** message will be displayed.

## 6.9. To Unlock the Keyboard

Press the UP and DOWN arrow keys together for more than 3 seconds until the **Pon** message displays.

## 6.10. The Continuous Cycle

When a defrost is not in progress, it can be activated by pressing and holding the UP arrow key for about 3 seconds. The compressor operates to maintain the CCS setpoint for the time set through the CCt parameter. The cycle can be terminated before the end of the set time using the same UP arrow for 3 seconds.

## 6.11. The ON/OFF Function



When **onF = oFF**, push the **ON/OFF** key to switch OFF the controller. The **OFF** message is displayed. In this configuration, the regulation is disabled.

To switch the controller ON, push the **ON/OFF** key again.



**WARNING!** Loads connected to the normally closed contacts of the relays are always supplied and under voltage (powered up), even if the device is in stand-by mode.

TITLE: PARAMETERS-INSIGHT FREEDOM DOORED CASES  
 ITEM: SZ39 PARAMETERS-INSIGHT FREEDOM DOORED CASES  
 CASE: INSIGHT DOORED CASES  
 REFRIGERANT: N/A  
 REV: A

**HUSSMANN®**

Group	Parameter	Description	Edit	Original	Vis. Level	Minimum	Maximum	Unit
Regulation	Hy	Differential	4	4	Pr1	1	45	°F
Regulation	LS	Minimum set point	27	27	Pr2	-58	34	°F
Regulation	US	Maximum set point	41	41	Pr2	34	230	°F
Probes	ot	Thermostat probe calibration	0	0	Pr1	-21	21	°F
Probes	P2P	Evaporator probe presence	no	no	Pr1			
Probes	oE	Evaporator probe calibration	0	0	Pr2	-21	21	°F
Probes	P3P	Third probe presence	no	no	Pr2			
Probes	o3	Third probe calibration	0	0	Pr2	-21	21	°F
Probes	P4P	Fourth probe presence	no	no	Pr2			
Probes	o4	Fourth probe calibration	0	0	Pr2	-21	21	°F
Regulation	odS	Outputs delay at start up	0	0	Pr2	0	255	min
Regulation	AC	Anti-short cycle delay	2	2	Pr1	0	50	min
Regulation	rtr	P1-P2 percentage for regulation	100	100	Pr2	0	100	
Regulation	CCt	Continuous cycle duration	0.00	0.00	Pr2			ora
Regulation	CCS	Set point for continuous cycle	34	34	Pr2	-58	230	°F
Regulation	Con	Compressor ON time with faulty probe	3	3	Pr2	0	255	min
Regulation	CoF	Compressor OFF time with faulty probe	2	2	Pr2	0	255	min
Regulation	CF	Temperature measurement unit	°F	°F	Pr2			
Regulation	rES	Resolution	dE	dE	Pr1			
Regulation	Lod	Probe displayed	P1	P1	Pr2			
Regulation	rEd	X-REP display	P1	P1	Pr2			
Regulation	dLy	Display temperature delay	0.00	0.00	Pr2			min
Regulation	dtr	P1-P2 percentage for display	50	50	Pr2	1	99	
Defrost	tdF	Defrost type	EL	EL	Pr2			
Defrost	dFP	Probe selection for first defrost	P1	P1	Pr2			
Defrost	dtE	Defrost termination temperature first defrost	48	48	Pr1	-58	122	°F
Defrost	idf	Interval between defrost cycles	24	24	Pr1	0	120	ora
Defrost	MdF	(Maximum) length for first defrost	40	40	Pr1	0	255	min
Defrost	dSd	Start defrost delay	0	0	Pr2	0	255	min
Defrost	dFd	Displaying during defrost	dEF	dEF	Pr2			
Defrost	dAd	Max display delay after defrost	30	30	Pr2	0	255	min
Defrost	Fdt	Draining time	0	0	Pr2	0	255	min
Defrost	dPo	First defrost after start-up	no	no	Pr2			
Defrost	dAF	Defrost delay after fast freezing	0.00	0.00	Pr2			ora
Fan	FnC	Fan operating mode	O_Y	O_Y	Pr1			
Fan	Fnd	Fan delay after defrost	0	0	Pr1	0	255	min
Fan	FCt	Differential of temperature for forced activation of fans	0	0	Pr2	0	90	°F
Fan	FSt	Fan stop temperature	2	2	Pr1	-58	122	°F
Fan	Fon	Fan on time with compressor off	0	0	Pr2	0	15	min
Fan	FoF	Fan off time with compressor off	0	0	Pr2	0	15	min
Fan	FAP	Probe selection for fan	nP	nP	Pr2			
Auxiliary	ACH	Kind of action for auxiliary relay	CL	CL	Pr2			
Auxiliary	SAA	Set point for auxiliary relay	0	0	Pr2	-58	230	°F
Auxiliary	SHy	Differential for auxiliary relay	2	2	Pr2	1	45	°F
Auxiliary	ArP	Probe selection for auxiliary relay	nP	nP	Pr2			
Auxiliary	Sdd	Auxiliary relay switched off during defrost	no	no	Pr2			
Alarm	ALP	Probe selection for temperature alarms	P1	P1	Pr2			
Alarm	ALC	Temperature alarms configuration	Ab	Ab	Pr2			
Alarm	ALU	Maximum temperature alarm	48	48	Pr1	20	230	°F
Alarm	ALL	Minimum temperature alarm	20	20	Pr1	-58	48	°F
Alarm	AFH	Differential for temperature alarm recovery	4	4	Pr2	1	45	°F
Alarm	ALd	Temperature alarm delay	30	30	Pr2	0	255	min
Alarm	dAo	Delay of temperature alarm at start up	2.00	2.00	Pr2			ora
Alarm	AP2	Probe selection for condenser temperature alarms	nP	nP	Pr2			
Alarm	AL2	Condenser low temperature alarm	-40	-40	Pr2	-58	230	°F
Alarm	AU2	Condenser high temperature alarm	110	110	Pr2	-58	230	°F
Alarm	AH2	Differ. for condenser temp. alarm recovery	45	45	Pr2	1	45	°F
Alarm	Ad2	Condenser temperature alarm delay	15	15	Pr2	0	255	min
Alarm	dA2	Delay of condenser temper. alarm at start up	1.30	1.30	Pr2			ora
Alarm	bLL	Compressor off for condenser low temperature alarm	no	no	Pr2			
Alarm	AC2	Compressor off for condenser high temperature alarm	no	no	Pr2			
Alarm	tbA	Alarm relay switched off by pushing a key	yes	yes	Pr2			
Configuration	oA2	Second relay configuration	Alr	Alr	Pr2			
Alarm	AOP	Alarm relay polarity	CL	CL	Pr2			
Digital inputs	i1P	Digital input 1 polarity	CL	CL	Pr1			
Digital inputs	i1F	Digital input 1 configuration	dor	dor	Pr1			
Digital inputs	i2P	Digital input 2 polarity	CL	CL	Pr1			
Digital inputs	i2F	Digital input 2 configuration	EAL	EAL	Pr2			
Digital inputs	did	Digital input 2 alarm delay	15	15	Pr2	0	255	min
Digital inputs	doA	Door alarm delay	15	15	Pr1	0	255	min
Digital inputs	nPS	Number of activation of pressure switch	15	15	Pr2	0	15	
Digital inputs	OdC	Compress and fan status when open door	F-C	F-C	Pr2			
Alarm	rrd	Regulation restart with door open alarm	yes	yes	Pr2			
Energy Saving	HES	Differential for Energy Saving	0	0	Pr2	-54	54	°F
Other	Adr	Serial address	1	1	Pr2	1	247	
Probes	PbC	Kind of probe	CtC	CtC	Pr2			
Configuration	OnF	On/off key configuration	nu	nu	Pr2			
Other	dP1	Probe 1 value			Pr1			°F
Other	dP2	Probe 2 value			Pr1			°F
Other	dP3	Probe 3 value			Pr1			°F
Other	dP4	Probe 4 value			Pr1			°F
Other	rSE	Real Set point (SET + ES + SETd)			Pr2			°F
Other	rEL	Firmware Release			Pr2			
Other	Ptb	Map code	3	3	Pr2	0	65535	
Regulation	SEt	Set point	34	34		27	41	°F

TITLE: PARAMETERS-INSIGHT FREEDOM OPEN CASES  
 ITEM: SZ40 PARAMETERS-INSIGHT FREEDOM OPEN CASES  
 CASE: INSIGHT OPEN CASES  
 REFRIGERANT: N/A  
 REV: A



Group	Parameter	Description	Edit	Original	Vis. Level	Minimum	Maximum	Unit
Regulation	Hy	Differential	4	4	Pr1	1	45	°F
Regulation	LS	Minimum set point	21	21	Pr2	-58	28	°F
Regulation	US	Maximum set point	35	35	Pr2	28	230	°F
Probes	ot	Thermostat probe calibration	0	0	Pr1	-21	21	°F
Probes	P2P	Evaporator probe presence	no	no	Pr1			
Probes	oE	Evaporator probe calibration	0	0	Pr2	-21	21	°F
Probes	P3P	Third probe presence	no	no	Pr2			
Probes	o3	Third probe calibration	0	0	Pr2	-21	21	°F
Probes	P4P	Fourth probe presence	no	no	Pr2			
Probes	o4	Fourth probe calibration	0	0	Pr2	-21	21	°F
Regulation	odS	Outputs delay at start up	0	0	Pr2	0	255	min
Regulation	AC	Anti-short cycle delay	2	2	Pr1	0	50	min
Regulation	rrr	P1-P2 percentage for regulation	100	100	Pr2	0	100	
Regulation	CCt	Continuous cycle duration	0.00	0.00	Pr2			ora
Regulation	CCS	Set point for continuous cycle	28	28	Pr2	-58	230	°F
Regulation	Con	Compressor ON time with faulty probe	3	3	Pr2	0	255	min
Regulation	CoF	Compressor OFF time with faulty probe	2	2	Pr2	0	255	min
Regulation	CF	Temperature measurement unit	°F	°F	Pr2			
Regulation	rES	Resolution	dE	dE	Pr1			
Regulation	Lod	Probe displayed	P1	P1	Pr2			
Regulation	rEd	X-REP display	P1	P1	Pr2			
Regulation	dLy	Display temperature delay	0.00	0.00	Pr2			min
Regulation	dtr	P1-P2 percentage for display	50	50	Pr2	1	99	
Defrost	tdF	Defrost type	EL	EL	Pr2			
Defrost	dFP	Probe selection for first defrost	P1	P1	Pr2			
Defrost	dTE	Defrost termination temperature first defrost	48	48	Pr1	-58	122	°F
Defrost	idF	Interval between defrost cycles	4	4	Pr1	0	120	ora
Defrost	MdF	(Maximum) length for first defrost	20	20	Pr1	0	255	min
Defrost	dSd	Start defrost delay	0	0	Pr2	0	255	min
Defrost	dFd	Displaying during defrost	dEF	dEF	Pr2			
Defrost	dAd	Max display delay after defrost	30	30	Pr2	0	255	min
Defrost	Fdt	Draining time	0	0	Pr2	0	255	min
Defrost	dPo	First defrost after start-up	no	no	Pr2			
Defrost	dAF	Defrost delay after fast freezing	0.00	0.00	Pr2			ora
Fan	FnC	Fan operating mode	O_Y	O_Y	Pr1			
Fan	Fnd	Fan delay after defrost	0	0	Pr1	0	255	min
Fan	FCt	Differential of temperature for forced activation of fans	0	0	Pr2	0	90	°F
Fan	FSt	Fan stop temperature	2	2	Pr1	-58	122	°F
Fan	Fon	Fan on time with compressor off	0	0	Pr2	0	15	min
Fan	FoF	Fan off time with compressor off	0	0	Pr2	0	15	min
Fan	FAP	Probe selection for fan	nP	nP	Pr2			
Auxiliary	ACH	Kind of action for auxiliary relay	CL	CL	Pr2			
Auxiliary	SAA	Set point for auxiliary relay	0	0	Pr2	-58	230	°F
Auxiliary	SHy	Differential for auxiliary relay	2	2	Pr2	1	45	°F
Auxiliary	ArP	Probe selection for auxiliary relay	nP	nP	Pr2			
Auxiliary	Sdd	Auxiliary relay switched off during defrost	no	no	Pr2			
Alarm	ALP	Probe selection for temperature alarms	P1	P1	Pr2			
Alarm	ALC	Temperature alarms configuration	Ab	Ab	Pr2			
Alarm	ALU	Maximum temperature alarm	48	48	Pr1	20	230	°F
Alarm	ALL	Minimum temperature alarm	20	20	Pr1	-58	48	°F
Alarm	AFH	Differential for temperature alarm recovery	4	4	Pr2	1	45	°F
Alarm	ALd	Temperature alarm delay	30	30	Pr2	0	255	min
Alarm	dAo	Delay of temperature alarm at start up	2.00	2.00	Pr2			ora
Alarm	AP2	Probe selection for condenser temperature alarms	nP	nP	Pr2			
Alarm	AL2	Condenser low temperature alarm	-40	-40	Pr2	-58	230	°F
Alarm	AU2	Condenser high temperature alarm	110	110	Pr2	-58	230	°F
Alarm	AH2	Differ. for condenser temp. alarm recovery	45	45	Pr2	1	45	°F
Alarm	Ad2	Condenser temperature alarm delay	15	15	Pr2	0	255	min
Alarm	dA2	Delay of condenser temper. alarm at start up	1.30	1.30	Pr2			ora
Alarm	bLL	Compressor off for condenser low temperature alarm	no	no	Pr2			
Alarm	AC2	Compressor off for condenser high temperature alarm	no	no	Pr2			
Alarm	tbA	Alarm relay switched off by pushing a key	yes	yes	Pr2			
Configuration	oA2	Second relay configuration	Alr	Alr	Pr2			
Alarm	AOP	Alarm relay polarity	CL	CL	Pr2			
Digital inputs	i1P	Digital input 1 polarity	CL	CL	Pr1			
Digital inputs	i1F	Digital input 1 configuration	dor	dor	Pr1			
Digital inputs	i2P	Digital input 2 polarity	CL	CL	Pr1			
Digital inputs	i2F	Digital input 2 configuration	EAL	EAL	Pr2			
Digital inputs	did	Digital input 2 alarm delay	15	15	Pr2	0	255	min
Digital inputs	doA	Door alarm delay	15	15	Pr1	0	255	min
Digital inputs	nPS	Number of activation of pressure switch	15	15	Pr2	0	15	
Digital inputs	OdC	Compress and fan status when open door	F-C	F-C	Pr2			
Alarm	rrd	Regulation restart with door open alarm	yes	yes	Pr2			
Energy Saving	HES	Differential for Energy Saving	0	0	Pr2	-54	54	°F
Other	Adr	Serial address	1	1	Pr2	1	247	
Probes	PbC	Kind of probe	CtC	CtC	Pr2			
Configuration	OnF	On/off key configuration	nu	nu	Pr2			
Other	dP1	Probe 1 value			Pr1			°F
Other	dP2	Probe 2 value			Pr1			°F
Other	dP3	Probe 3 value			Pr1			°F
Other	dP4	Probe 4 value			Pr1			°F
Other	rSE	Real Set point (SET + ES + SETd)			Pr2			°F
Other	rEL	Firmware Release			Pr2			
Other	Ptb	Map code	3	3	Pr2	0	65535	
Regulation	SEt	Set point	28	28		21	35	°F

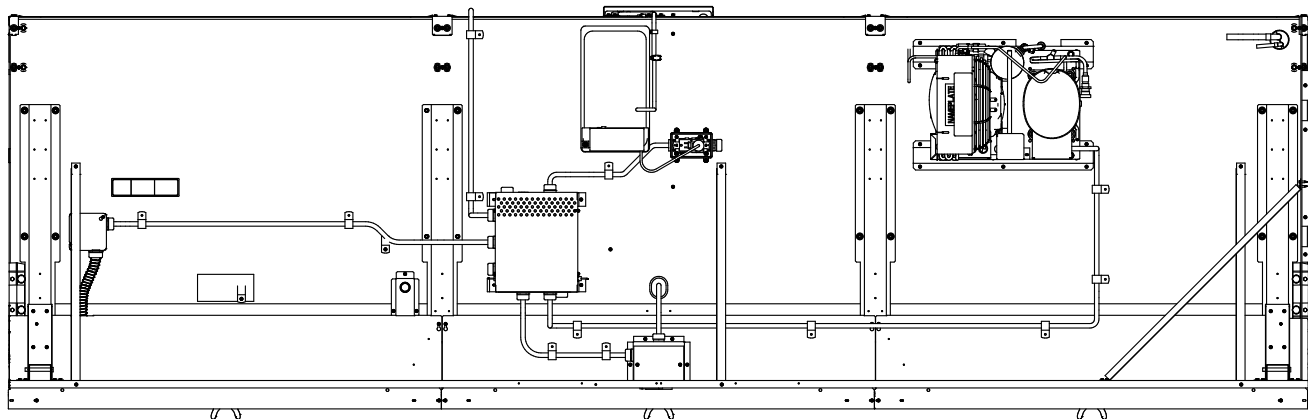
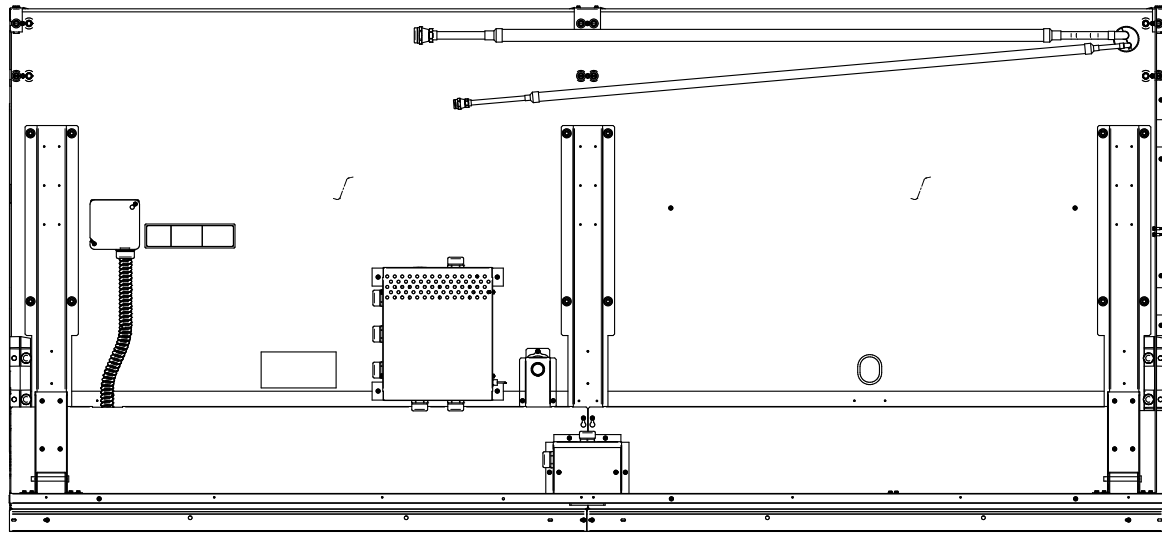
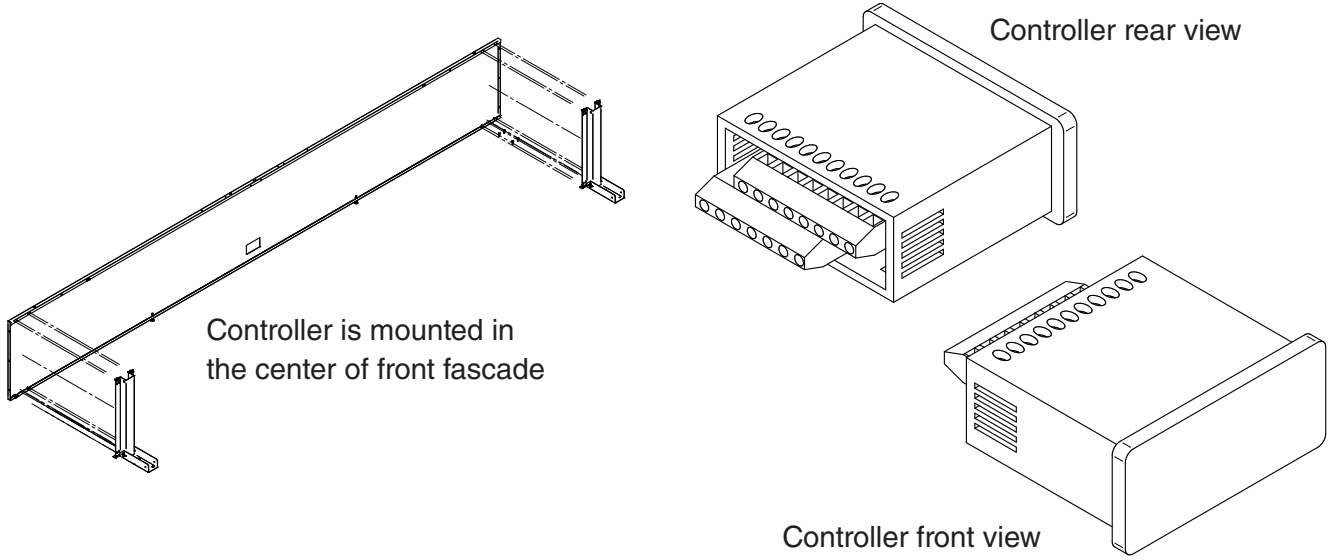

## SPECIFICATIONS

<b>Dimensions</b>	<b>Case:</b> <b>Front:</b> 32 mm x 74 mm <b>Depth:</b> 60 mm
	<b>Panel Mount:</b> 71 mm x 29 mm panel cut-out
<b>Housing</b>	Self extinguishing ABS
<b>Protection</b>	IP 20
	<b>Frontal:</b> IP65
<b>Connections</b>	Screw terminal block $\leq 2.5 \text{ mm}^2$ wiring
<b>Power Supply (depending on the model)</b>	24VAC $\pm 10\%$ 230VAC $\pm 10\%$ , 50/60Hz 110VAC $\pm 10\%$ , 50/60Hz
<b>Power Absorption</b>	3VA max
<b>Display</b>	3 digits, red LED, 14.2 mm high
<b>Inputs</b>	Up to four (4) NTC or PT1000 probes
	<b>Digital:</b> free voltage contact
<b>Relay Outputs</b>	<b>Compressor:</b> SPST 8(3)A, 250VAC or SPST 16A 250VAC
	<b>AUX:</b> SPDT 8(3)A, 250VAC or SPST 16(6)A 250VAC
	<b>Fan:</b> SPST 5A, 250VAC
	<b>Defrost:</b> SPDT 8(3)A, 250VAC
<b>Data Storing</b>	On the non-volatile memory (EEPROM)
<b>Internal Clock Back-up</b>	24 hours
<b>Kind of Action</b>	1B
<b>Pollution Grade</b>	2
<b>Software Class</b>	A
<b>Rated Impulsive Voltage</b>	2500V
<b>Overvoltage Category</b>	II
<b>Temperatures</b>	<b>Operating:</b> 0 to 55°C
	<b>Storage:</b> -30 to 85°C
<b>Relative Humidity</b>	20 to 85% (no condensing)
<b>Measuring and Regulation Range</b>	<b>NTC probe:</b> -40 to 110°C (-40 to 230°F)
	<b>PT1000 probe:</b> -100 to 150°C (-148 to 302°F)
<b>Resolution</b>	0.1°C or 1°C or 1°F (selectable)
<b>Accuracy (ambient temperature 25°C)</b>	$\pm 0.7^\circ\text{C} \pm 1$ digit

## ALARM SIGNALS

Message	Cause	Outputs
<b>P1</b>	Room probe failure	Compressor output acc. to par. <b>Con</b> and <b>CoF</b>
<b>P2</b>	Evaporator probe failure	Defrost end is timed
<b>P3</b>	Third probe failure	Outputs unchanged
<b>P4</b>	Fourth probe failure	Outputs unchanged
<b>HA</b>	Maximum temperature alarm	Outputs unchanged
<b>LA</b>	Minimum temperature alarm	Outputs unchanged
<b>HA2</b>	Condenser high temperature	It depends on the <b>Ac2</b> parameter
<b>LA2</b>	Condenser low temperature	It depends on the <b>bLL</b> parameter
<b>dA</b>	Door open	Compressor and fans restart
<b>EA</b>	External alarm	Output unchanged
<b>CA</b>	Serious external alarm (i1F=bAL)	All outputs OFF
<b>CA</b>	Pressure switch alarm (i1F=PAL)	All outputs OFF
<b>rtc</b>	Real time clock alarm	Alarm output ON; Other outputs unchanged; Defrosts according to par. <b>IdF</b> Set real time clock has to be set
<b>rtF</b>	Real time clock board failure	Alarm output ON; Other outputs unchanged; Defrosts according to par. <b>IdF</b> Contact the service

### DRIP PIPING / FACADES / SPLASHGUARDS / BUMPERS

#### WASTE OUTLET AND WATER SEAL

Insight merchandisers have one waste outlet located in the front center of the bottom or righthand side for 8 ft cases. Water seals are field installed with waste outlet to prevent air leakage and insect entrance into the case. Tees and clean-outs are supplied for each case.

A hat-shaped strainer is also shipped with the merchandiser. Place strainer over the waste outlet as shown below.

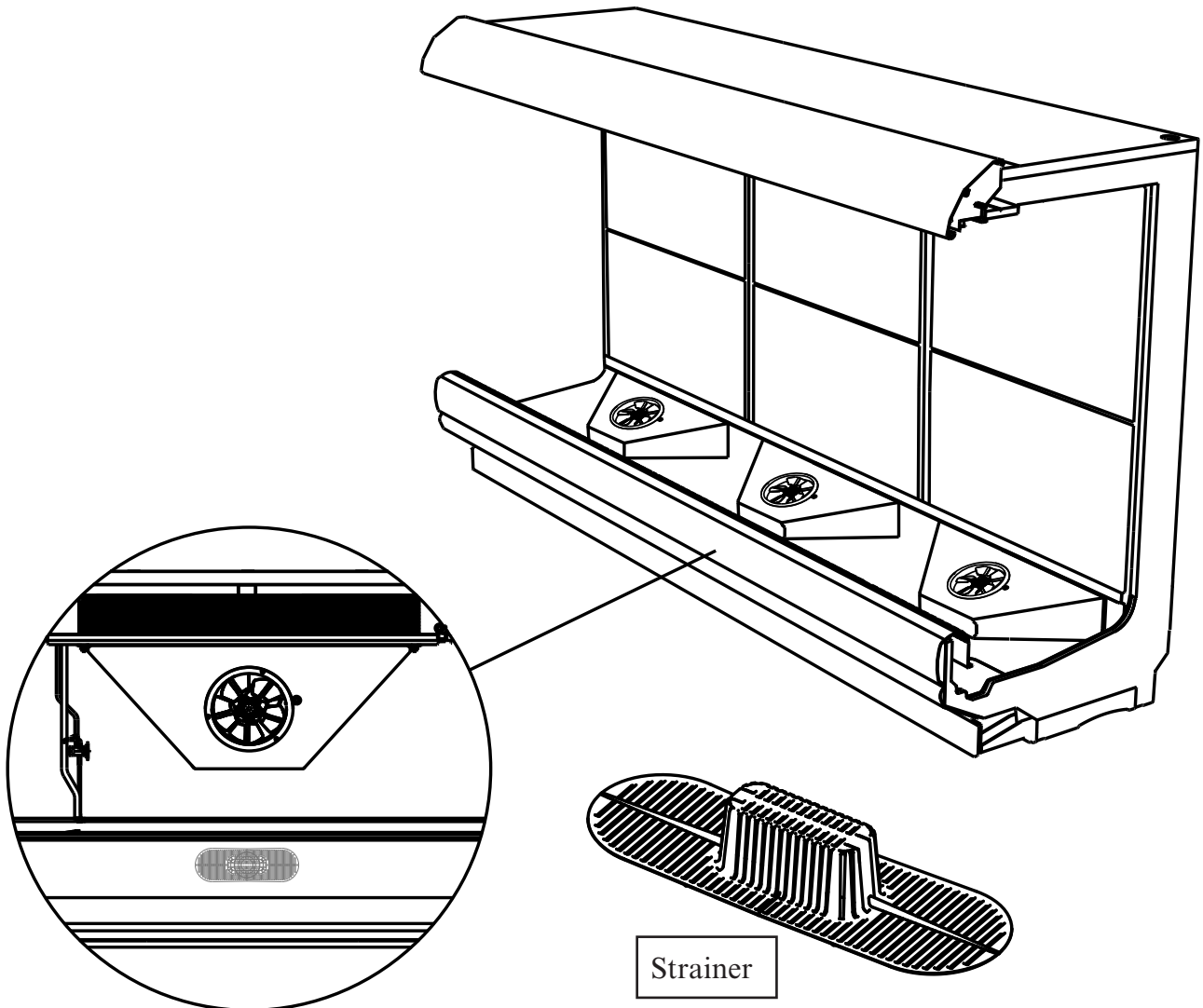
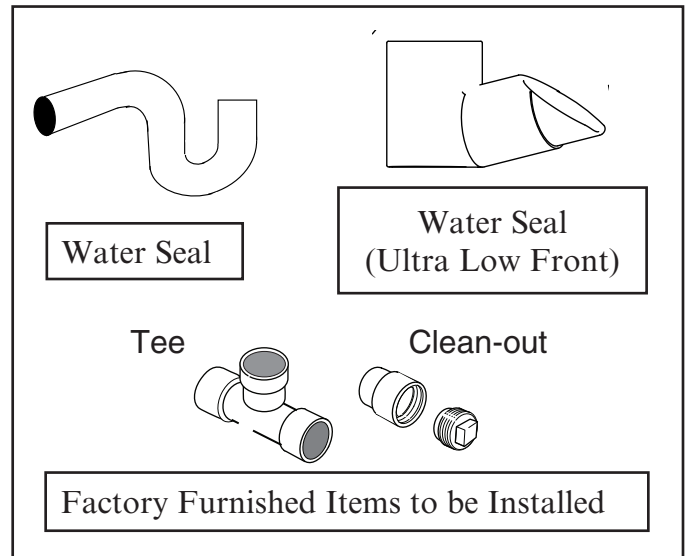

## INSTALLING DRIP PIPING

Poorly or improperly installed drip pipes can seriously interfere with the merchandiser's operation and result in costly maintenance and product losses.

Optional drip pipe arrangements are shown on the next page. It is the installing contractor's responsibility to consult local agencies for local code requirements. Assemble the components using field-supplied PVC primer and glue according to the manufacturers direction.

Please follow the recommendations listed below when installing drip pipes to ensure proper installation.

1. When connecting drip piping, the "water seal" must be used as part of the drip piping to prevent air leakage or insect entrance. Never use two water seals in series in any one drip pipe. Double water seals in series will cause an air lock and prevent draining.

2. Pitch the drip piping in the direction of flow. **There should be a minimum pitch of ¼ in. per ft (20 mm per 1 m).**

3. Avoid long runs of drip piping. Long runs make it impossible to provide the pitch necessary for good drainage.

4. All connections must be watertight and sealed with the appropriate PVC or ABS cement.



**Never use drip piping smaller than the nominal diameter of the pipe or water seal supplied with the merchandiser.**



**It is the installing contractor's responsibility to consult local agencies for local code requirements.**

### Drip Piping Example for Standard Case Height (Not for Ultra Low Front Cases)

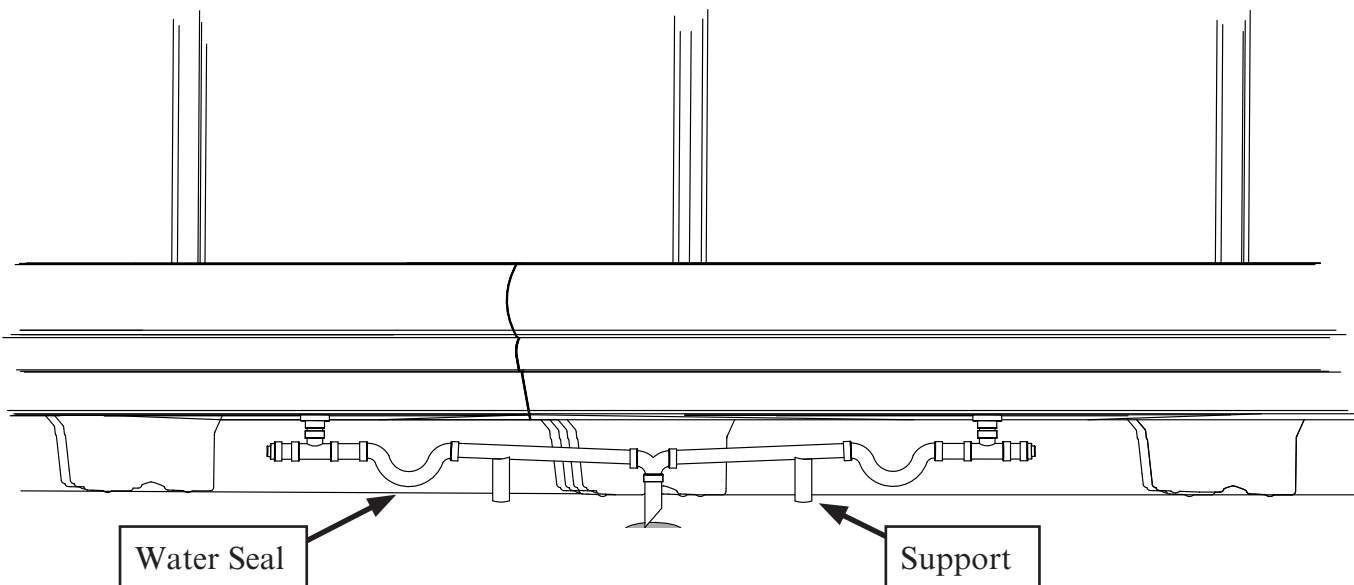

5. Ensure that drip piping is supported to relieve any stress on drip pipe connectors and drain hub. Drip piping **MUST** be supported no more than 24 in. from drain hub tee.

6. Provide a suitable air break between flood rim of the floor drain and outlet of drip pipe. To meet code on low base merchandisers, it may be necessary to install a field-supplied drip pipe reducer.



An alternative is to cut the last section of drip pipe at an angle.

7. Prevent drip pipes from freezing:

Do not install drip pipes in contact with uninsulated suction lines. Suction lines should be insulated with a nonabsorbent insulation material.

Where drip pipes are located in dead air spaces, such as between merchandisers or between a merchandiser and a store wall, provide means to prevent freezing.

### Flush Floor Drip Piping Example for Ultra Low Front Cases



**Elbow is to be oriented toward rear of case. Install elbow to tee, place elbow on hub. Push elbow until it meets the liner.**

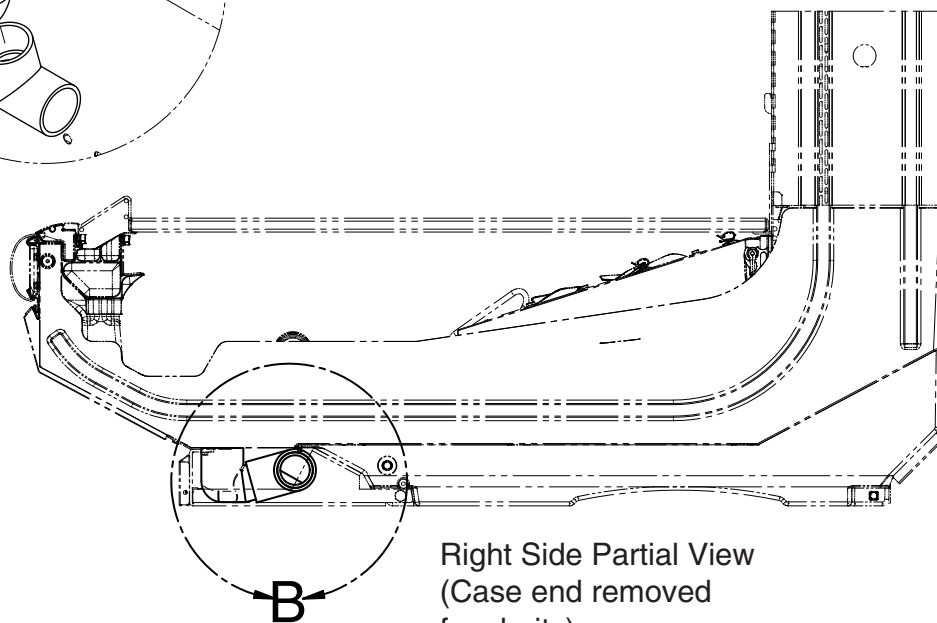
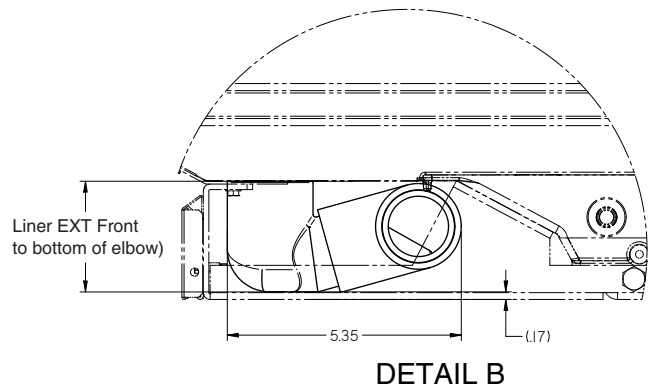
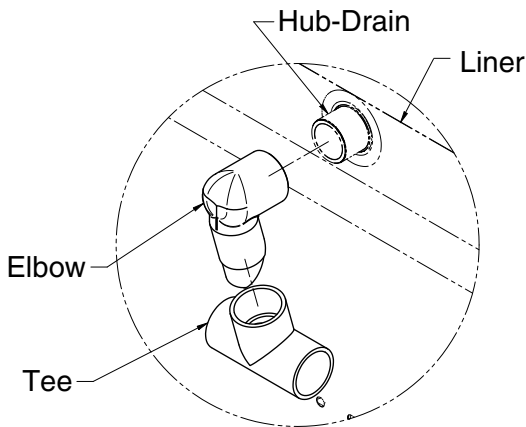

Right Side Partial View  
(Case end removed for clarity)

**DRIP PIPING / FACADES / SPLASHGUARDS / BUMPERS**

**Optional Hub Drain Drip Piping Example  
for Ultra Low Front Cases**

There is limited space underneath the case for piping ultra low front cases. If there is a drain hub in the floor, use the ultra low front piping kit. This extends the splashguard forward. Follow the waste outlet location drawings on the following pages to install the drip piping in the correct location.

Item Number	Title	Quantity	Comments
1	ELBOW- AIR SEAL INSIGHT	1	FACTORY INSTALLED
2	TEE-1.25	1	FIELD INSTALLED
3	BUSHING-PVC REDUCER 1.250 X .50 SLIP	1	FIELD INSTALLED
4	REDUCER BUSHING-1.25x1.00	1	FIELD INSTALLED
5	PLUG-1.00	1	FIELD INSTALLED
6	PIPE-PVC .500 X 3.5 LONG	4	FIELD INSTALLED
7	ELBOW-PVC 90 DEG .500 SLIP	3	FIELD INSTALLED
8	ELBOW-PVC 22.5 DEG .500 SLIP	1	FIELD INSTALLED

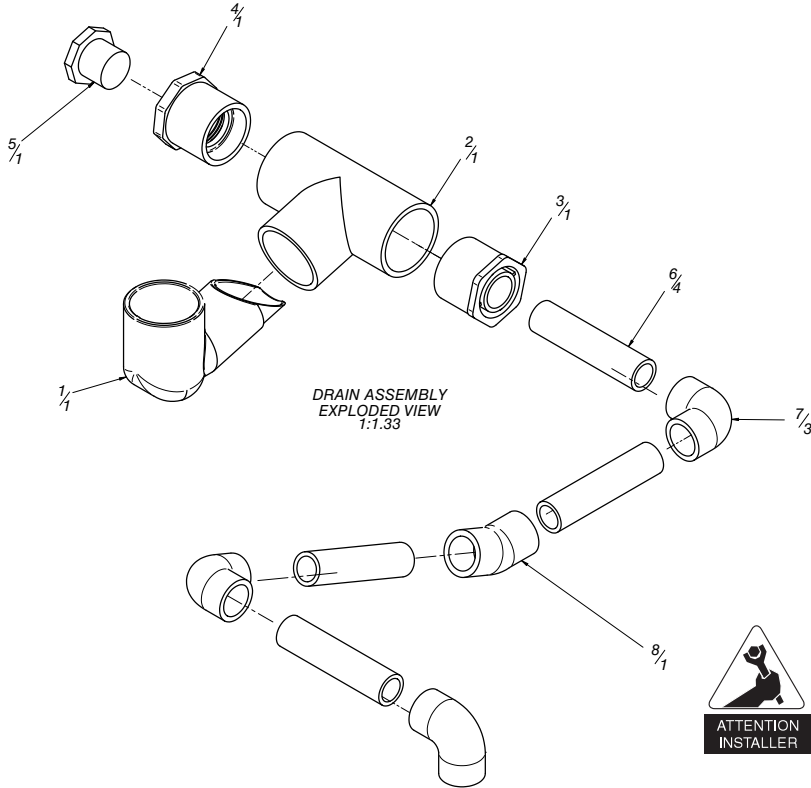

**Elbow is to be oriented toward rear of case.  
Install elbow to tee, place elbow on hub.  
Push elbow until it meets the liner.**

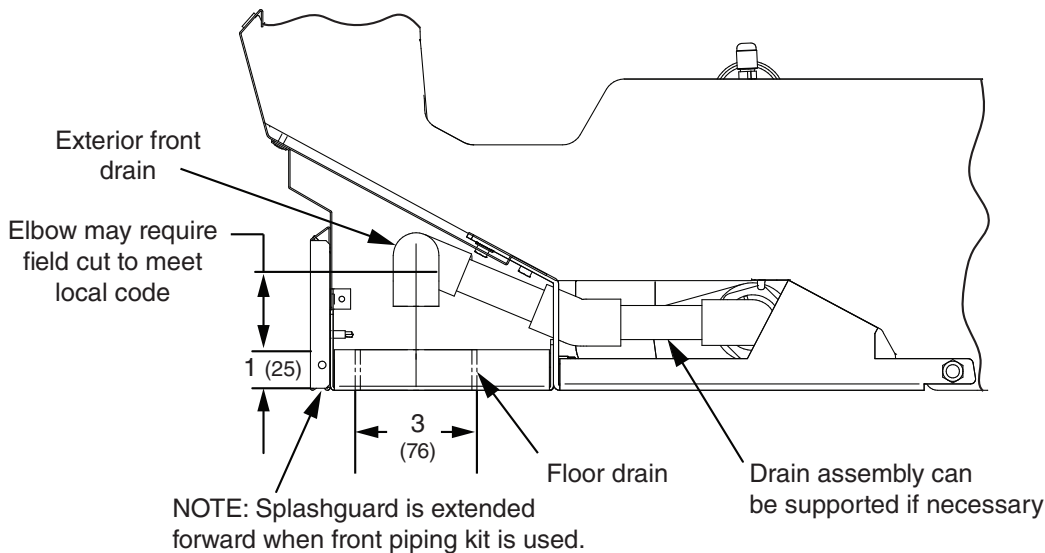

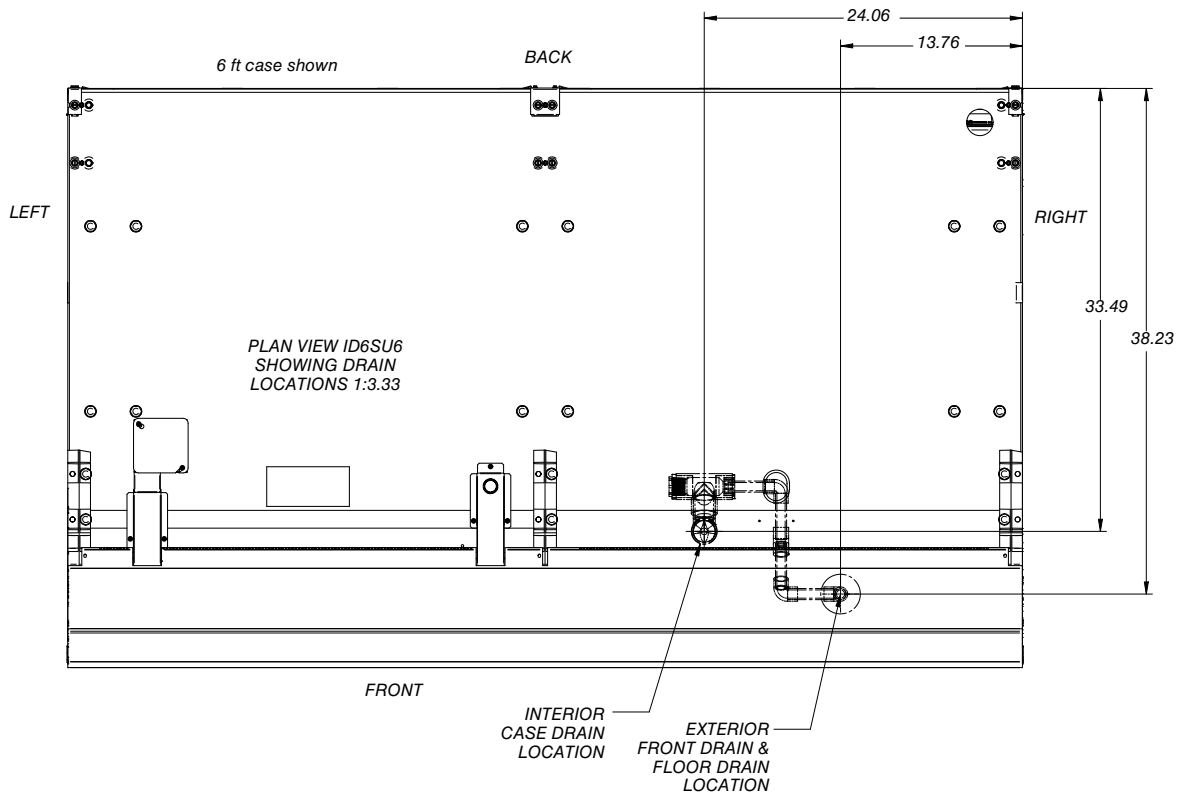
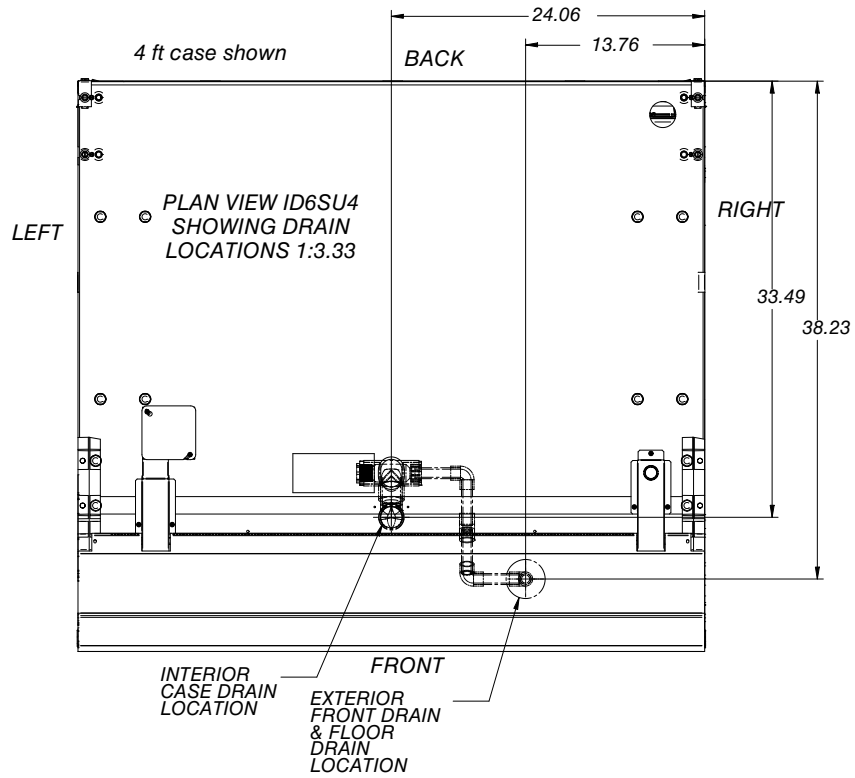

# DRIP PIPING / FACADES / SPLASHGUARDS / BUMPERS

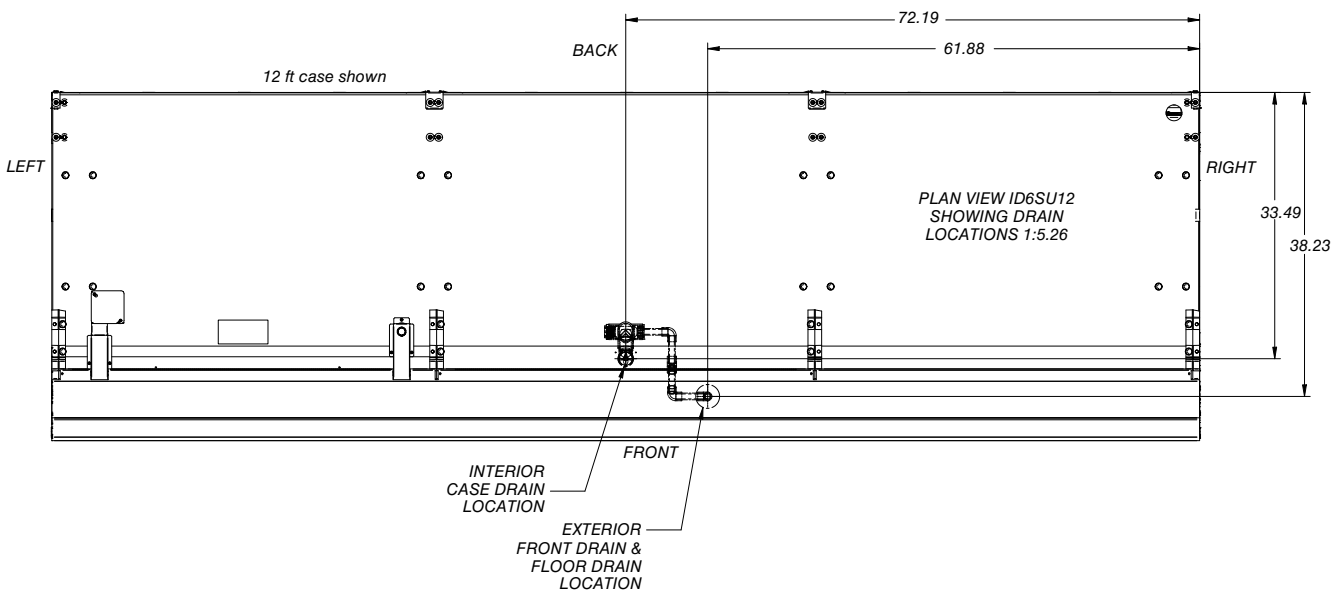
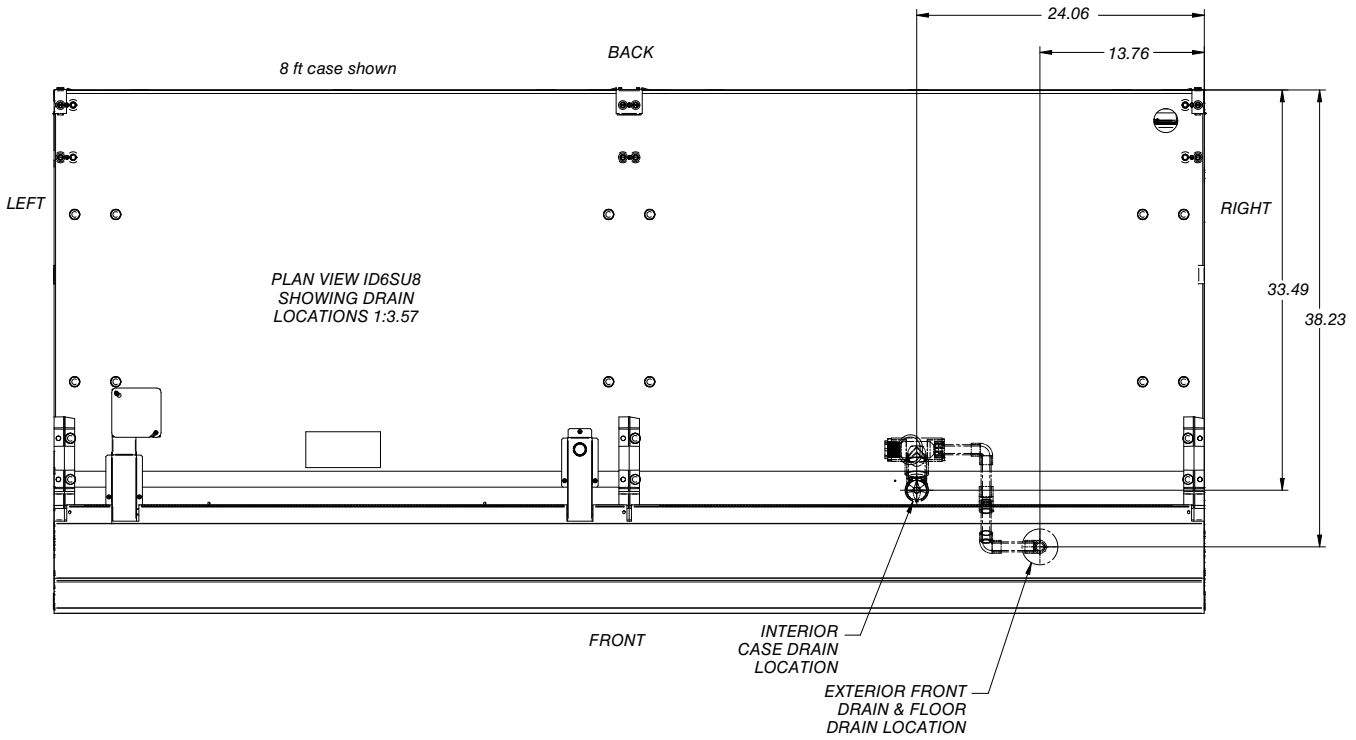

### INSTALLING FACADES

Refer to the Hinge Location illustration to determine where hinges will be positioned on the top of the merchandiser.

Notice that hinge position will vary with the number of doors of the merchandiser.

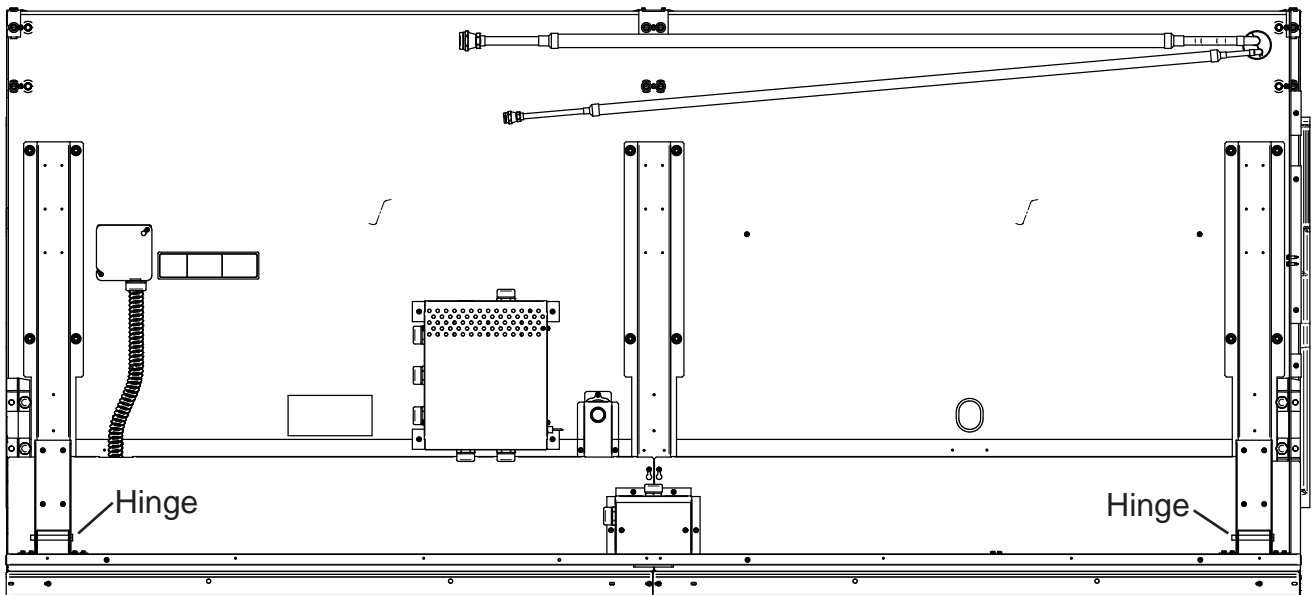
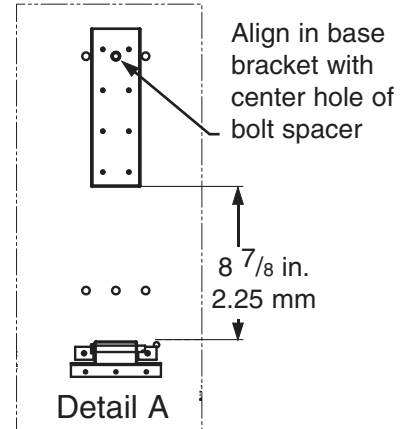

Facade Hinge Locations

Identify the corresponding positions on the facade panel, then fasten the hinges to the facade panel with provided screws.

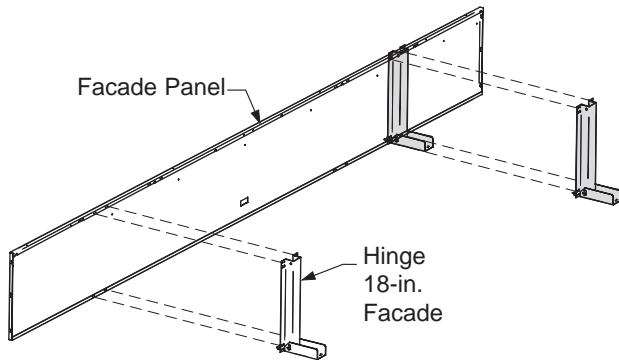

**Fasten Hinges to Facade**

Raise the elevator bolts at the bottom of the facade. Attach reinforcement straps to the Facade Panel with provided screws.

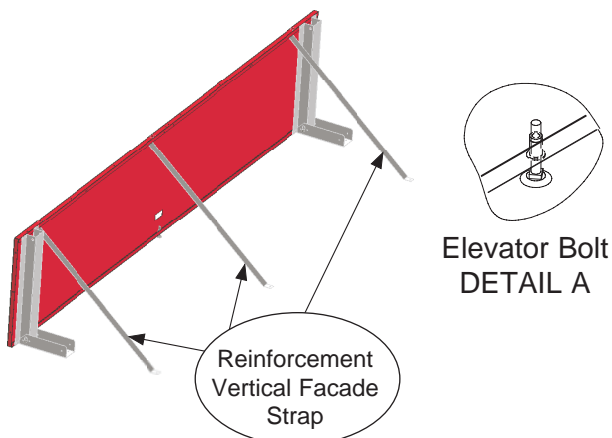

**Fasten Reinforcement Strap**

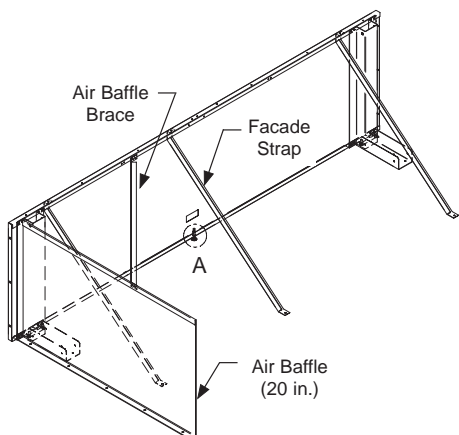

**Install Air Baffle**

Position the facade centered on case length and recessed from the fascia as shown in the side view. One hinge will be between the condensing unit and the electrical box. If necessary, the electrical box can be relocated.

Line up trim channel edge with edge of facade panel

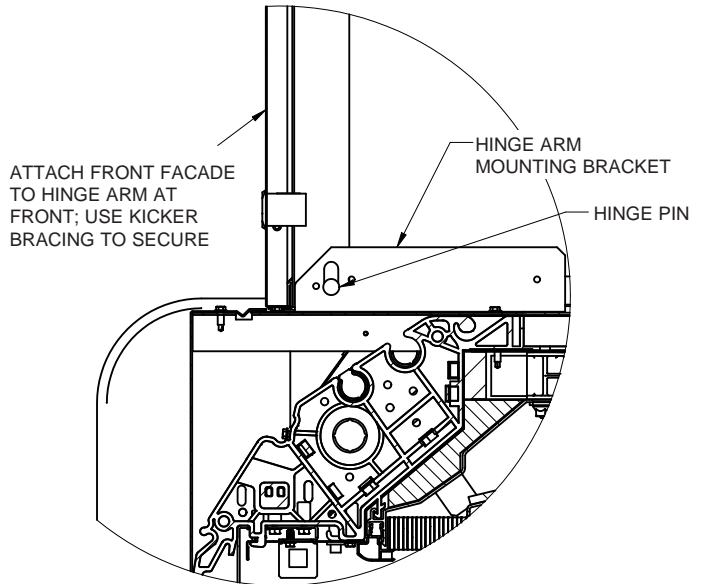

Attach facade channel to top of canopy fascia using #8 x 1/2 sheet metal screws provided. Place front of trim channel at edge of flat surface on canopy fascia top.

Fasten the hinge. Fasten the reinforcement straps after hinges are attached using provided screws.

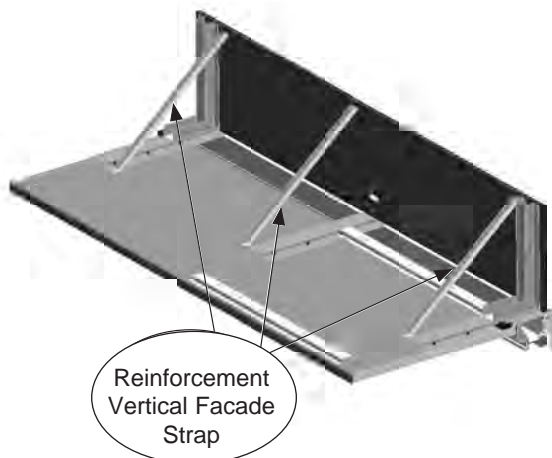

## Final Alignment / Fit & Finish

### Fascia Top Cap Alignment

Applies to (IP4/IM5/ID5/ID6/IC6)

Fascia Top Cap can slide toward the center of (multideck) case lineups to eliminate gaps.

1. Pull fascia top cap to uncover fixing screws.

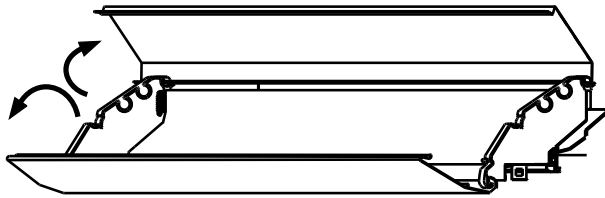

2. Loosen the screws of fascia top cap.

3. Move fascia top cap towards the lineup center. Tighten the screws after finishing the alignment.

4. Snap fascia top cap to closed position.

5. Install fascia trim (optional) between joints and at ends. Hook at bottom first, then snap top into place.

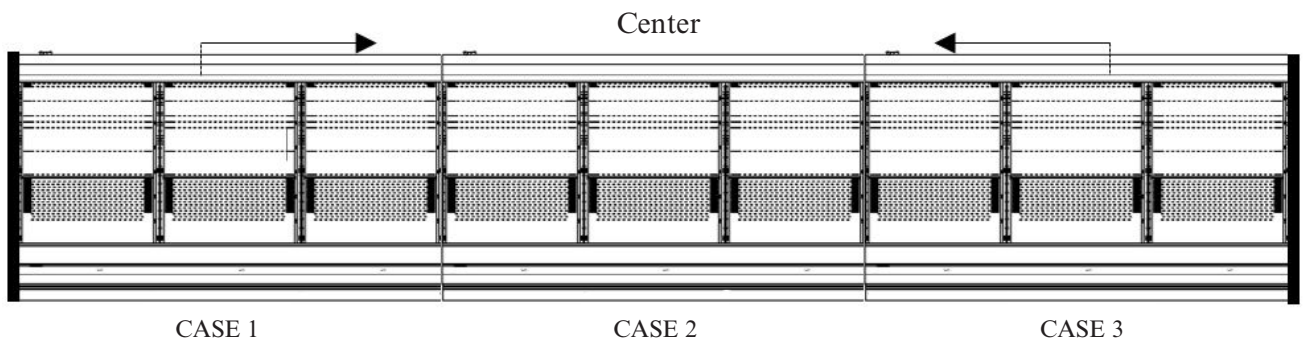
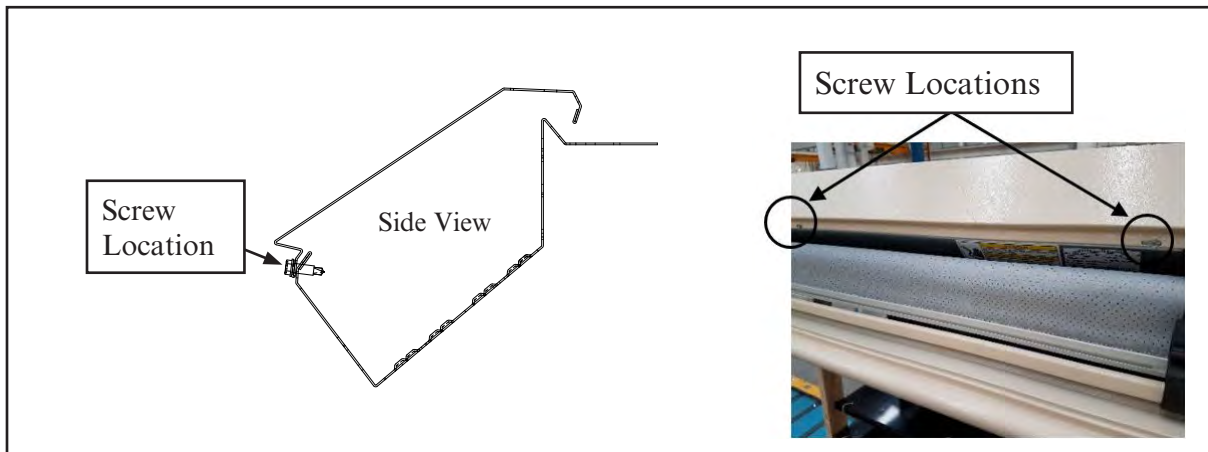
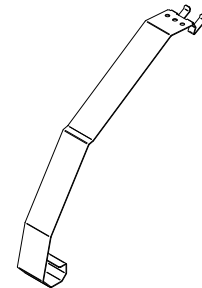

**Fascia Panel Alignment**

Applies to (IP4/IM5/ID5/ID6/IC6)

Fascia panels can slide toward the center of (multideck) case lineups to eliminate gaps.

1. Slide fascia panels toward lineup center as shown in the illustration below.

2. Place optional fascia trim between fascia joints between end panel and fascia and between case lineup joints. Install tape to joint first, then attach bottom and top fascia trim.

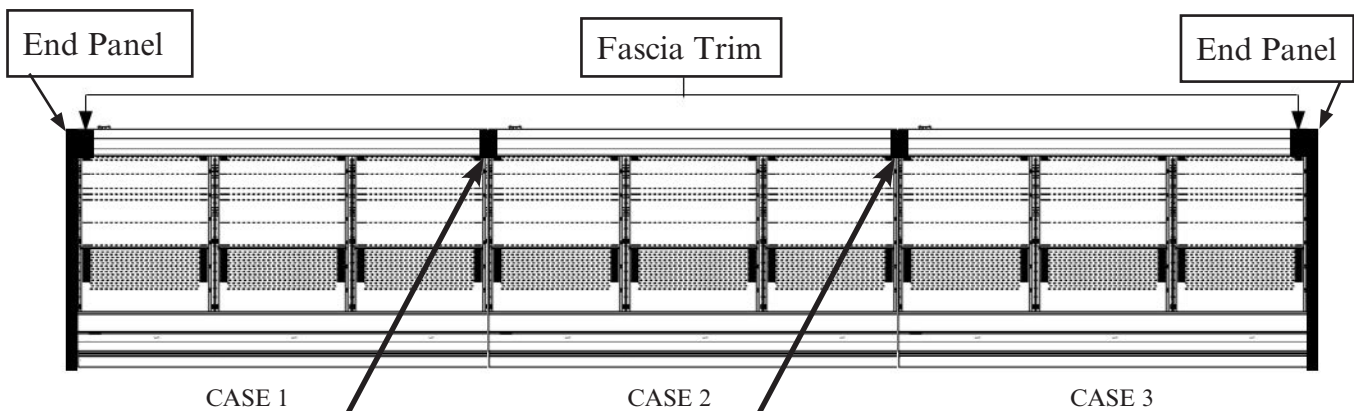
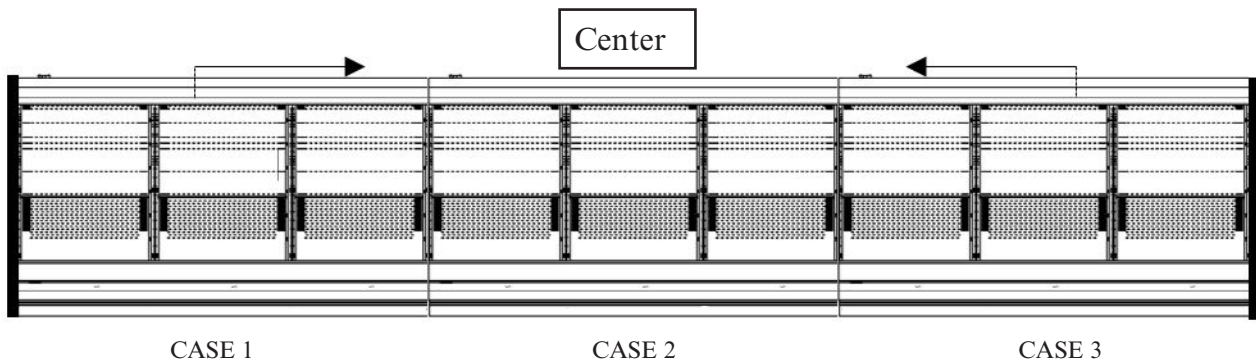
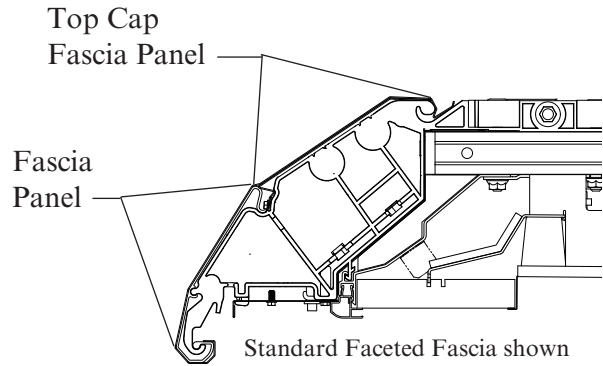

Optional Fascia Trim can be applied to case-to-case Fascia Joints

### Front Panel Alignment

Front Panels can slide toward the center of (multideck) case lineups to eliminate gaps.

1. Loosen the front panel screws located at the bottom of Front Panel.
2. Slide front panel towards the lineup center to eliminate gaps between front panels. Tighten the screws after finishing the alignment.

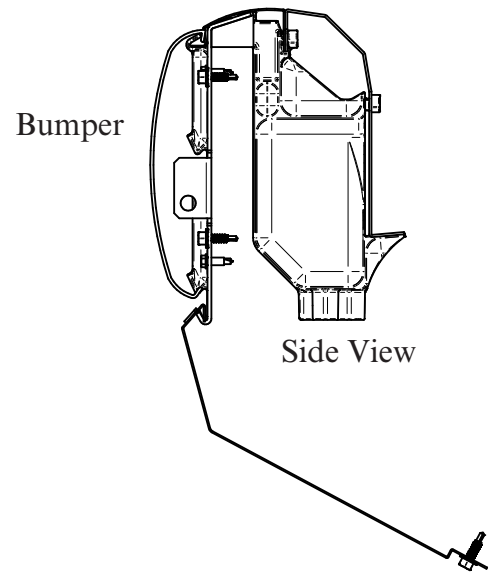

**NOTE** Remove Front Skid Brace before aligning Front Panels. Align Panels before installing the Splashguard Front and Bumpers.

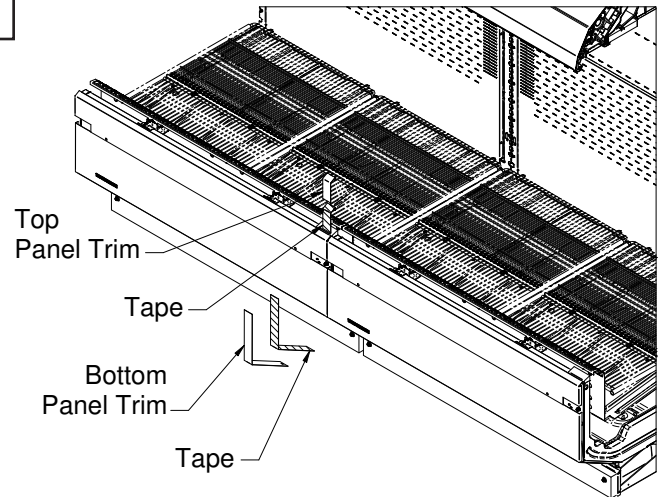

Front Panel Screw

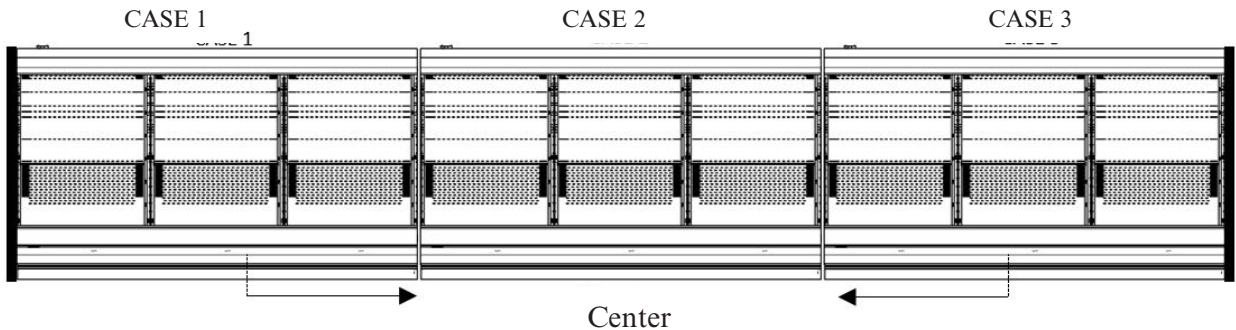

**INSTALLING SPLASHGUARD BRACKETS**

Position splashguard brackets at the front base (legs) of the merchandiser near the floor. Loosely assemble Splashguard Bracket using #8 x 5/8 inch SM screws as shown in Detail A below. More detail of splashguard installation shown on next page.

**IMPORTANT** Install Drip Piping Before Installing Splashguards

**WARNING**  
 » Use caution when working around refrigeration lines or water lines, damage to equipment and personal injury could occur.

**Splashguard Bracket and Panel Installation (12 ft Shown)**

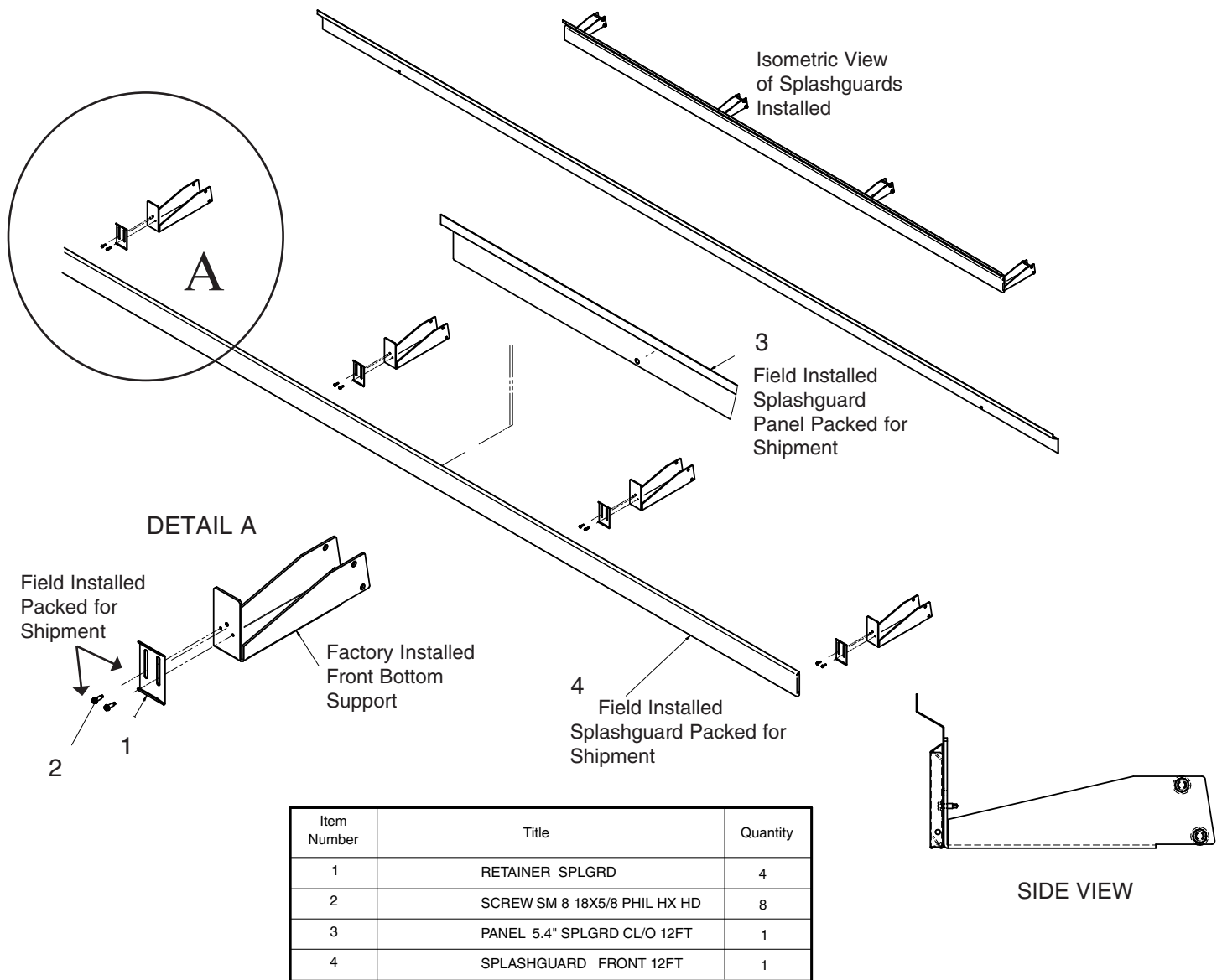

Item Number	Title	Quantity
1	RETAINER SPLGRD	4
2	SCREW SM 8 18X5/8 PHIL HX HD	8
3	PANEL 5.4" SPLGRD CL/O 12FT	1
4	SPLASHGUARD FRONT 12FT	1

## INSTALLING SPLASHGUARDS (Retainers and Panels)

Splashguards are shipped inside each merchandiser, 4 brackets for 12 ft case, 3 for 6 ft, etc. **AFTER** merchandisers have been leveled and joined, and all drip piping, electrical and refrigeration work has been completed, install the splashguard.

### To Install Splashguards:

1. Check to be sure that all splashguard brackets are level with the floor. Refer to previous page for additional exploded view pictures.
2. Loosely attach the lower splashguard retainer bracket using # 8 SM screws (1).
3. Install close-off panel as shown in (2 & 3). Slide splashguard close-off panel between the bracket and lower front support.
4. Raise the splashguard close-off panel to where the top fits into bend on the lower color panel, then tighten the splashguard brackets.
5. Fit the lower splashguard into the slots on the lower splashguard retainer. Lower splashguard snaps into place (4).

### To install OPTIONAL cove trim to the splashguard:

1. Remove all dirt, wax and grease from the area of the splashguard where adhesion will be necessary to ensure a secure installation.
2. Apply a good contact cement to the cove trim and allow proper drying time according to the directions supplied with the cement.
3. Install the trim to the splashguard so that it is lying flush with the floor. **DO NOT SEAL THE TRIM TO THE FLOOR.**
4. **If required by local health codes** the Cove Trim may be sealed to the floor, using a silicone type sealer. Sealant must be removed and replaced when servicing.

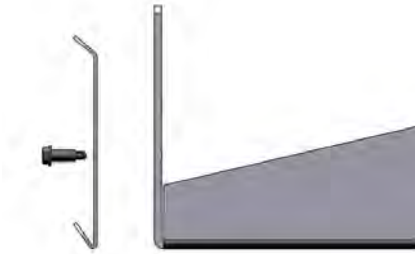

1.

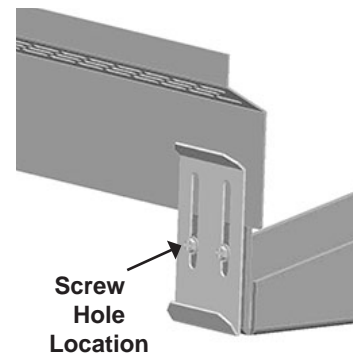

2.

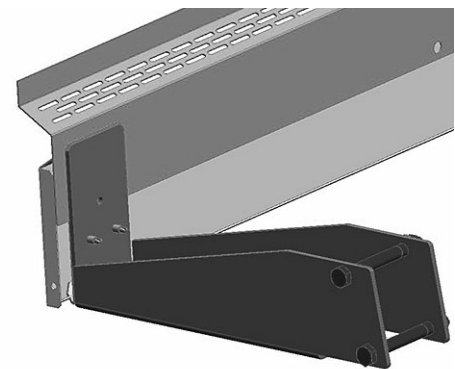

Rear View

3.

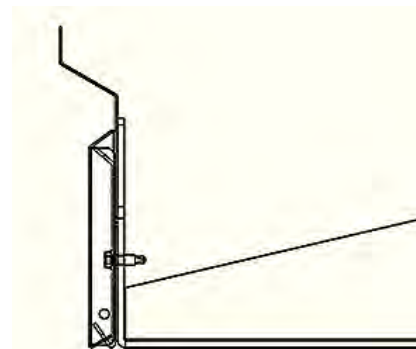

4.

**SPLASHGUARD ALIGNMENT  
TO ELIMINATE GAPS IN CASES LINE-UP**

1. Slide Splashguard towards line-up center to eliminate Splashguards gaps.

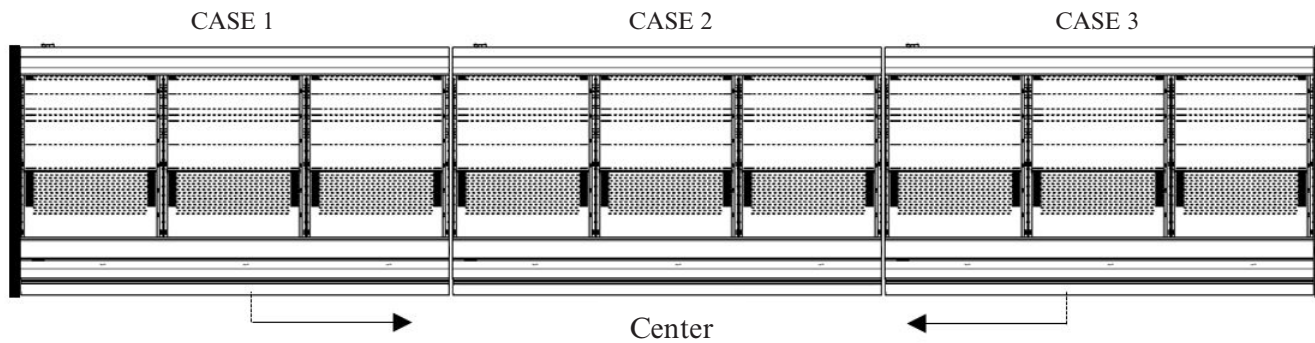

## START UP / OPERATION

# ATTENTION

Merchandiser must operate for 24 hours before loading product!

Regularly check merchandiser temperatures.

Do not break the cold chain. Keep products in cooler or freezer before loading into merchandiser.

Medium temperature merchandisers are designed for loading **ONLY** pre-chilled products.



## EXPANSION VALVE ADJUSTMENT

Expansion valves on Freedom cases are pre-adjusted from the factory, but some adjustment may be necessary to adjust for specific store conditions. Before attempting to adjust valves, make sure the evaporator is either clear or only lightly covered with frost, and that the merchandiser is within 10 deg F (6.5 deg C) of its expected operating temperature.

After system startup and after 24 hours of operation make sure to verify that the oil level in the compressor is at  $1/2$  site glass on the compressor. Add compressor manufacturer's recommended type oil as needed to maintain correct level.

### CAUTION

- » Do NOT operate refrigeration system outside Type I and Type II Ambient Operating Conditions. Poor performance of refrigeration system may result from continuous operation outside of the following conditions:
- » ANSI/NSF-7 Type I – Display Refrigerator / Freezer Intended for 75°F / 55%RH Ambient Application
- » ANSI/NSF-7 Type II – Display Refrigerator / Freezer Intended for 80°F / 55%RH Ambient Application
- » Evaporator pans may overflow, causing flooding during continuous operation in extreme store temperatures.

If refrigeration system operation is required for functional verification, please follow the recommendations below:

- » Install display case shelves before operation.
- » Drafts from open doors, fans, or other sources must be avoided.
- » Air discharge and return flues must remain open and free of obstruction at all times.
- » Temporarily set the refrigeration control knob to the warmest position for operation during non-controlled ambient conditions, to keep defrost water build-up to a minimum.
- » If heater pans have been de-energized following a defrost cycle, standing water will remain in the pans. Re-energize power to the pans long enough to remove remaining water before restarting refrigeration during non-controlled ambient conditions.

### WARNING

- » Do not walk on top of case. Do not store items or flammable materials on top of the case.

### CAUTION

- » Tipping Hazard! Case tipping may occur if cases are not properly leveled and secured, or if cases are not properly loaded.

## START UP / OPERATION

### START UP

See the merchandiser's Technical Data Sheet for refrigerant settings and defrost requirements. Bring merchandisers down to the operating temperatures listed on the data sheet.

Each four-foot section has its own evaporator coil and pre-set adjustable thermostatic expansion valve (TEV). No adjustment is required.

The TEV has been factory set to provide the recommended performance settings as specified on the merchandiser data sheets.

### STOCKING

Product should NOT be placed in case until case is at proper operating temperature.

Proper rotation of product during stocking is necessary to prevent product loss. Always bring the oldest product to the front and set the newest to the back.

AIR DISCHARGE AND RETURN FLUES MUST REMAIN OPEN AND FREE OF OBSTRUCTION AT ALL TIMES to provide proper refrigeration and air curtain performance. Do not allow product, packages, signs, etc. to block these grilles. Do not use non-approved shelving, baskets, display racks, or any accessory that could hamper air curtain performance.

### LOAD LIMITS

Do not stock shelves above load limit decals. Shelf life of perishables will be short if load limit is violated. **AT NO TIME SHOULD THE MERCHANDISERS BE STOCKED BEYOND THE LOAD LIMITS INDICATED.**

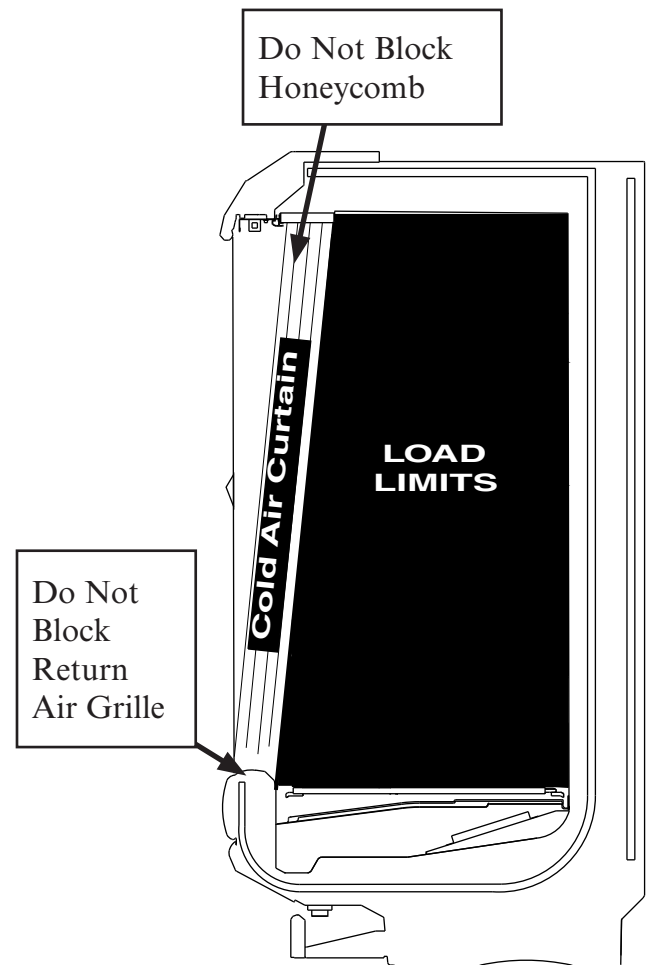

**SHELF MAXIMUM WEIGHT LIMITS**

Hussmann merchandiser shelves are designed to support the maximum weight load limits as indicated in this table.

Exceeding these maximum weight load limits may cause damage to the shelf or shelves, damage to the merchandiser, damage to store products, and potentially create a hazardous condition for customers and staff. Exceeding the indicated maximum weight load limits constitutes misuse as described in the Hussmann Limited Warranty.

**Weight Limits for Merchandiser Shelving**

Nominal Shelf Depth	Maximum Load Limit
12 in. (305 mm)	125 lb (56.7 kg)
14 in. (357 mm)	125 lb (56.7 kg)
16 in. (406 mm)	200 lb (90.7 kg)
18 in. (457 mm)	200 lb (90.7 kg)
20 in. (508 mm)	250 lb (113.4 kg)
22 in. (559 mm)	250 lb (113.4 kg)
24 in. (610 mm)	250 lb (113.4 kg)
Heavy Duty Beverage Shelf 16 in. (406 mm)	300 lb (136 kg)
Heavy Duty Beverage Shelf 18 in. (457 mm)	320 lb (145.1 kg)
Heavy Duty Beverage Shelf 20 in. (508 mm)	350 lb (158.8 kg)
Heavy Duty Beverage Shelf 22 in. (559 mm)	350 lb (158.8 kg)
Heavy Duty Beverage Shelf 24 in. (610 mm)	350 lb (158.8 kg)

\*Shelf load limits at 0° tilt

**Merchandiser Shelf Depths**

	Recommended	Maximum
Narrow (37 in. Merchandiser Depths)	16 in. (406 mm)	18 in. (457 mm)
Standard (42 in. Merchandiser Depths)	22 in. (559 mm)	24 in. (610 mm)

**MULTI-DECK SHELF CONFIGURATION**

Shelves are individually mounted in 1 in. (25 mm) increments and have two-, three-, or four-position brackets, permitting shelves to be placed in a flat or down-tilt position (see illustration). Front product stops are recommended when shelves are placed in the down-tilt position.

Case performance will be degraded if peg shelves are used without baffles. Unauthorized specialty shelving may cause poor merchandiser performance. Consult your Hussmann representative to ensure optimum performance of Hussmann equipment.

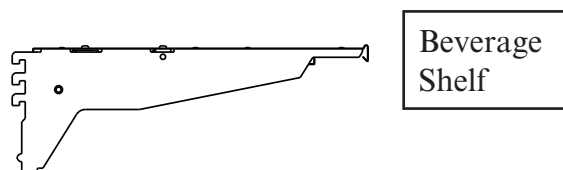
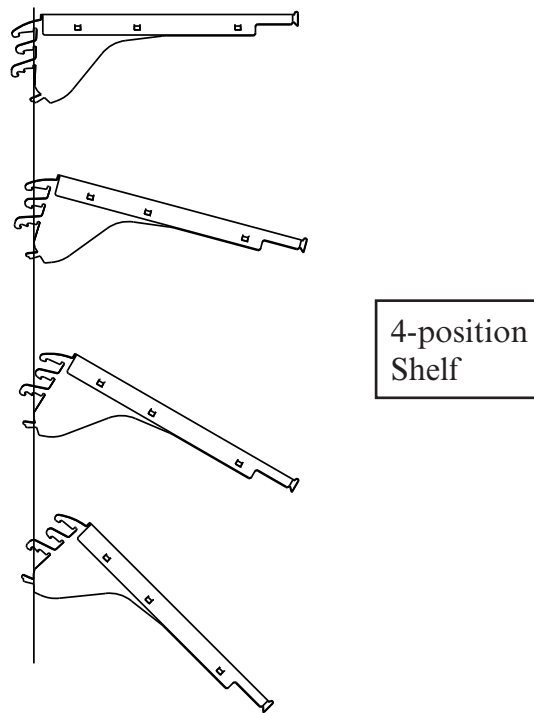

### LED FIXTURES

These merchandisers are equipped with 24 volt DC power supplies that power the LEDs. The power supplies are located in the canopy wire-way. EcoShine II LEDs work well for dimming or on/off operation using an occupancy sensor (optional kits).

They can be turned on and off in a cold environment with no warm-up time and no negative impact on lamp life. Hussmann EcoShine II LED light fixtures normally perform for more than 50,000 hours. Shelf lights are IP67 rated for water resistance. Canopy lights are IP54 rated for water splashes.

**⚠ WARNING**

— LOCK OUT / TAG OUT —

» To avoid serious injury or death from electrical shock, always disconnect the electrical power at the main disconnect when servicing or replacing any electrical component. This includes, but is not limited to, such items as doors, lights, fans, heaters, and thermostats.

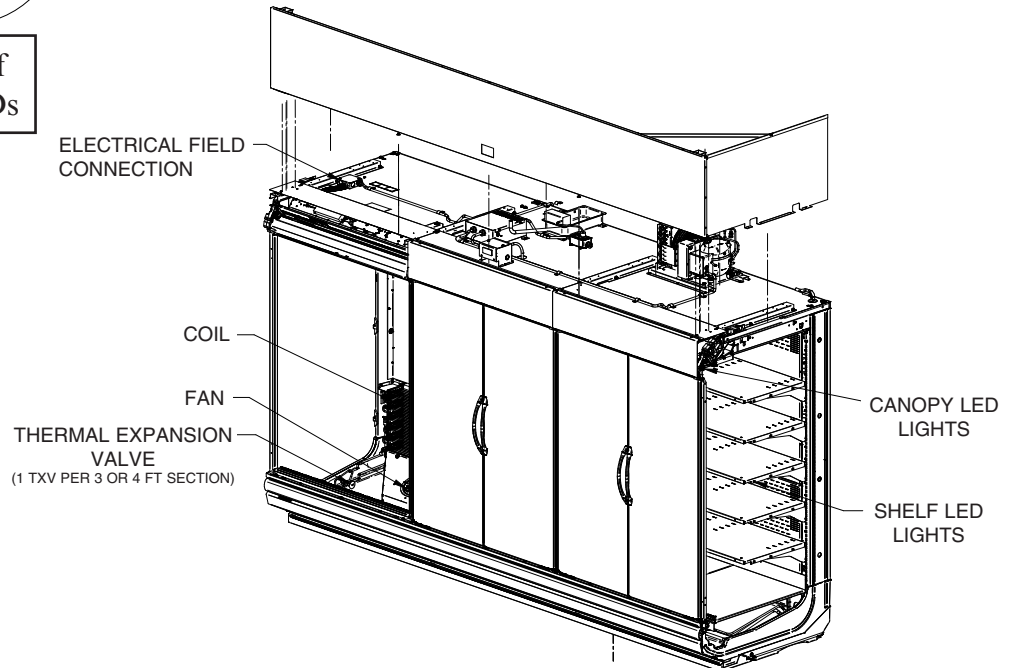
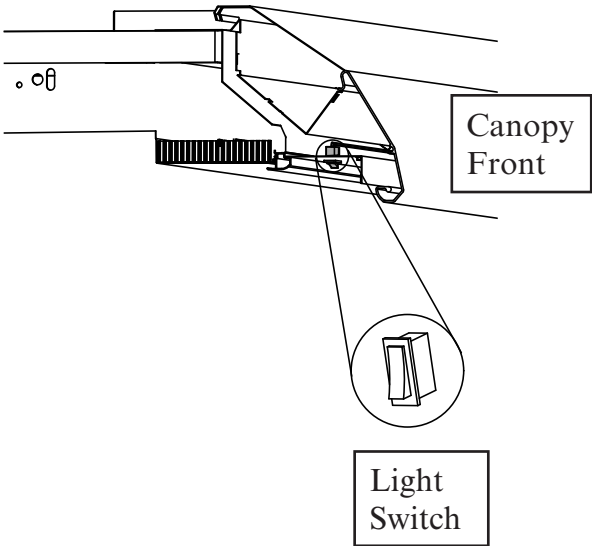
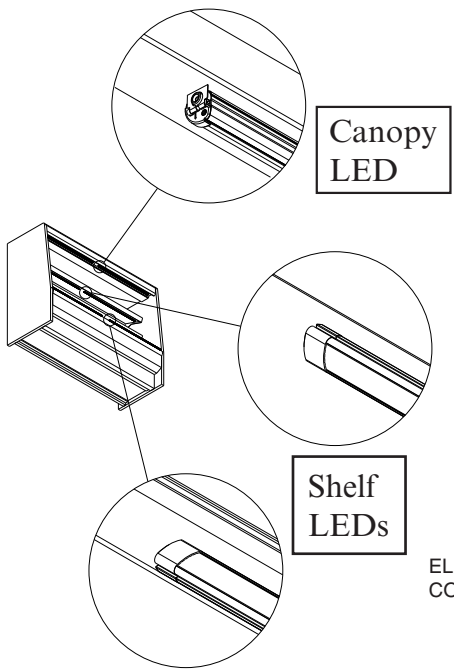

## PROCEDURE FOR INSTALLING LIGHTED SHELVES

Follow these instructions to ensure good contact between male and female connectors.

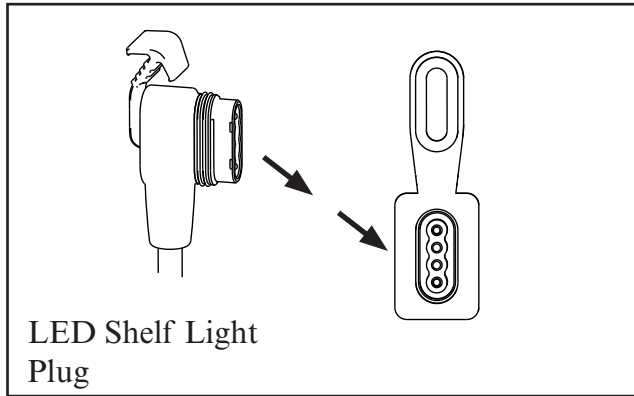

1. Remove any products from the case and place in cooler. Shut off power to the merchandiser.
2. Turn off Canopy Light Switch. Remove all packed shelves.
3. **Engage each power socket cap, and ensure that each cap is fully seated before cleaning.** Ensure the proper seating of the cap at all times when the plug is not engaged.

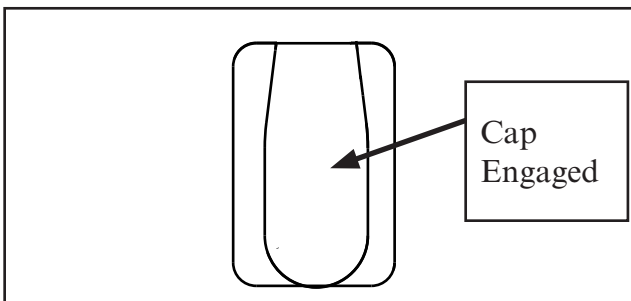

4. Clean the merchandiser as described in the *Care and Cleaning* paragraphs of **Section 5 — Maintenance**. **Keep liquid out of sockets.** (Allow merchandiser shelves to dry before turning on shelf power.)

5. Verify power to the merchandiser is turned ON. Verify that the merchandiser light switch is turned OFF. The switch is located in the canopy, on the left side.

6. Refer to the illustration at the top of the next page. Note that other models will have fewer rows of shelves. Starting from the left-hand bottom section, choose the location for the first shelf, X-1.

7. Secure the shelf in the slotted upright. Make certain that the shelf is level and that ends are in the same slot on the left and right upright. Markings on the shelf uprights indicate the proper shelf notch for each shelf location. It is important that shelf brackets be properly seated in the slotted upright.

8. Working from left to right, install the next shelf, X-2, to the right of the first shelf you installed. Always work from left to right and from the bottom up in each 8 ft (2438 mm) and 12 ft (3685 mm) merchandiser.

9. After each shelf on the bottom row is in position, be sure to remove the cap and insert the shelf connector. **Push firmly.**

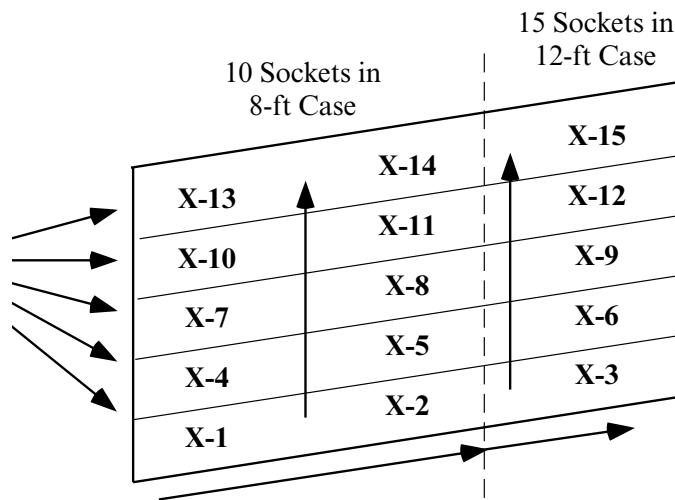

**Always work Left to Right,  
and Bottom to Top**

10. Turn ON the merchandiser light switch after the entire bottom row has been installed in either 8 or 12 ft (2438 or 3658 mm) merchandisers. The shelf lights should light.



***If an LED shelf light does not operate:***

- Turn off light switch.
- Remove and firmly re-insert each shelf plug.
- Turn on light switch.

If lights do not operate after checking the items listed above, contact the installation contractor.

11. Using the row of shelves just installed as support, set the next shelf, X-4, in the desired location. Remove the cap and insert the shelf plug. Continue working left to right installing shelves X-5 and X-6.

Note: Since the location for the remaining shelves, X-4 to X-15, may be directly over the rear wall receptacle, the shelf should be plugged in before engaging brackets in the uprights. The lower shelf will support the weight of the next shelf until it is plugged in. After installing each shelf, verify that its plug is properly connected to its rear wall receptacle. Continue working row by row, bottom up, left to right.

**Important**

**If a shelf is plugged in and the lamp does not work, verify the case light switch is ON.**

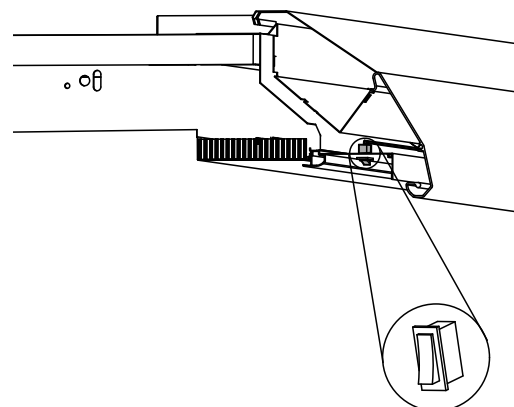

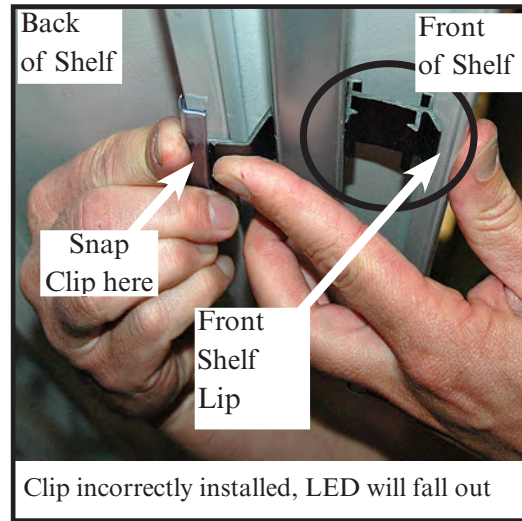
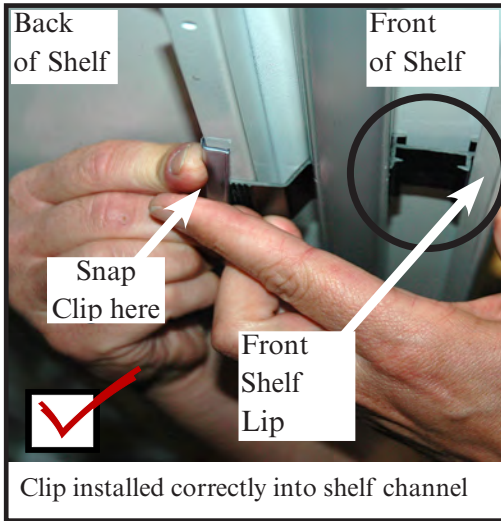

Shelf LED clips must be first inserted into the front lip underneath the shelf as shown at left. Next the retaining clip is “snapped on” to the rear of the LED clip.

## PRODUCT STOP INSTALLATION

Use caution when installing Product Stops. Product stop legs must be inserted at an angle. When product leg goes through the shelf, it must rest **BEHIND** the LED shelf light as shown below.

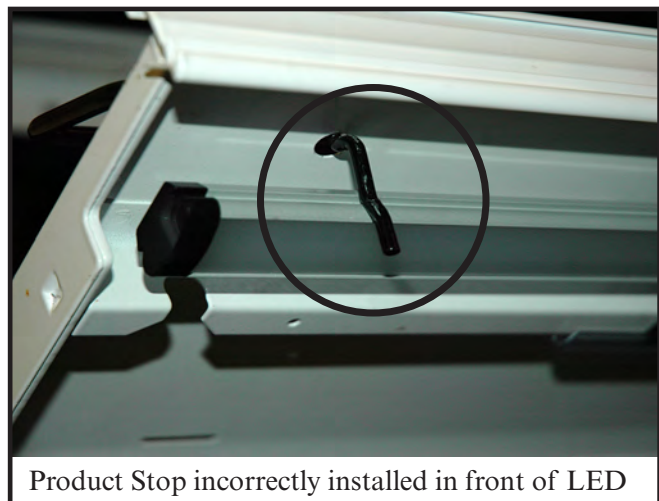
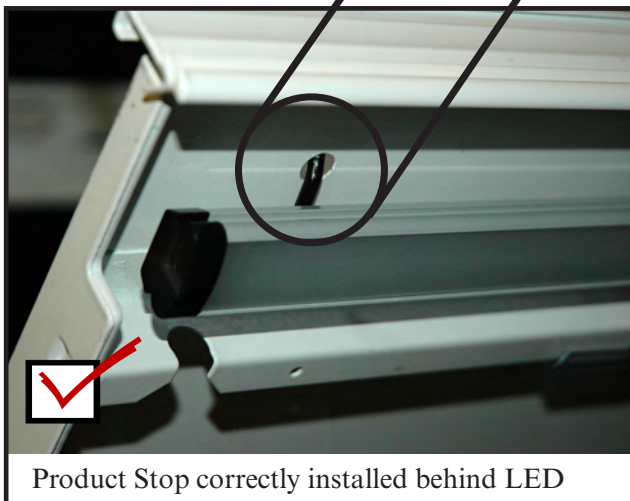
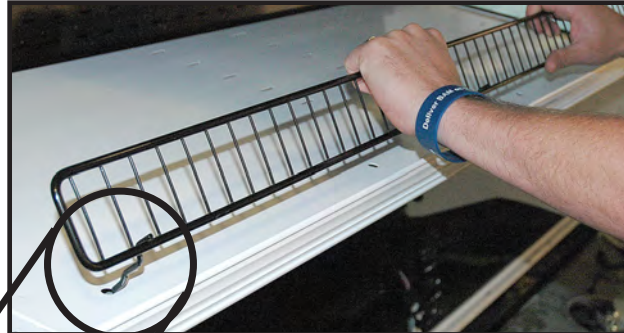

### INSTALLING FDA/NSF REQUIRED THERMOMETER

The thermometer requirement does not apply to display refrigerators intended for bulk produce (refer to page 1-1). Please note that the tape cannot be exposed after installation.

This thermometer may not be required or provided in other countries. Check for local code requirements.

## This is an NSF-7 & US FDA Food Code Required Thermometer

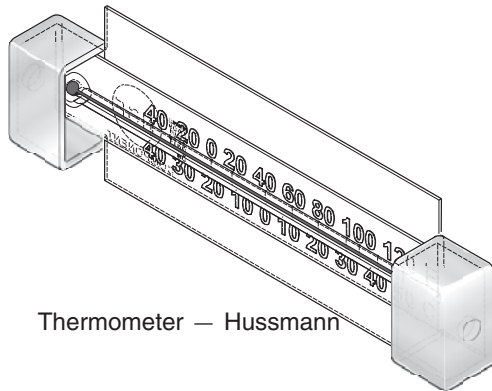

Thermometer — Husmann

Husmann Corporation • 12999 St. Charles Rock Road • Bridgeton, MO 63044-2483  
U.S. & Canada 1-800-922-1919 Mexico 1-800-890-2900 www.husmann.com  
© 2013 • Husmann Corporation

### Suggested Mounting Locations in Single Deck Glass Front Merchandisers

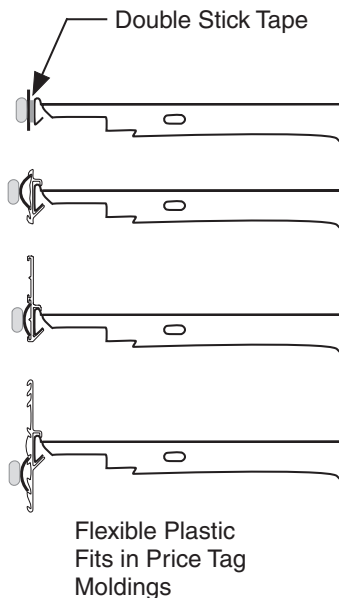
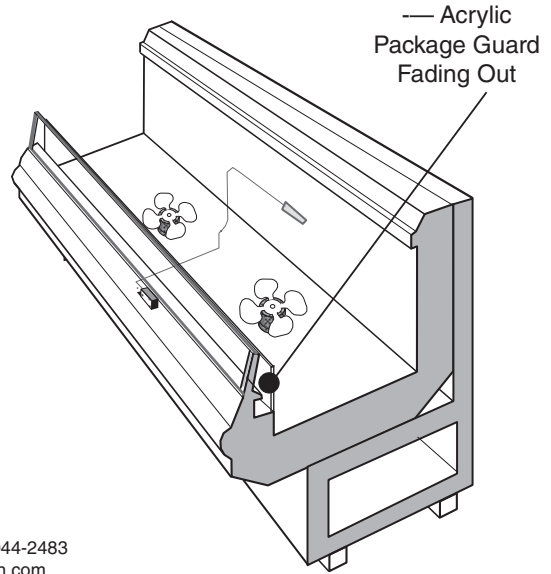

Flexible Plastic Fits in Price Tag Mouldings

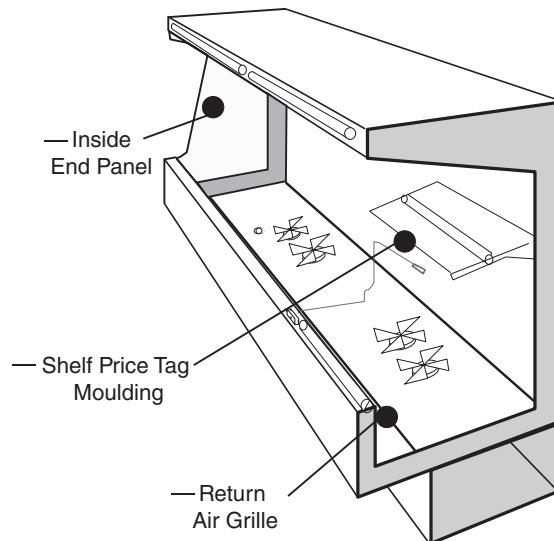

Suggested Mounting Locations in Multi-deck Merchandisers

# Important – Please read!

---

This thermometer is provided in response to United States Food and Drug Administration (US FDA) Food Code [ <http://www.fda.gov/> ] and National Sanitation Foundation (NSF / ANSI) Standard 7 [ <http://www.nsf.org/> ]

---

Each installation will be different depending on how the unit is stocked, shopping patterns in the department and ambient conditions of the store. The suggested locations provided herein are possible locations. It is the responsibility of the purchaser / user to determine the location within the food storage area of the unit that best meets the code requirements above.

The thermometer may need to be moved several times to find the warmest location. Mounting options include flexible plastic for price tag molding application, magnet applied to back of flexible plastic for steel end wall, and double stick tape. Tape must not be exposed after installation.

Questions about either code should be addressed to local agencies or other appropriate officials.

---

**Keep with merchandiser  
or give to store manager.**

**DO NOT DESTROY.**

# MAINTENANCE

## CARE AND CLEANING

Long life and satisfactory performance of any equipment is dependent upon the care it receives. To ensure long life, proper sanitation and minimum maintenance costs, these merchandisers should be thoroughly cleaned, all debris removed and the interiors washed down as part of a regular store sanitation schedule.

### Fan Plenum

To facilitate cleaning, the fan plenum is hinged. After cleaning be sure the plenum is properly lowered into position or product loss will result due to improper refrigeration.

Fan motor harness plug must be securely connected. Do not disconnect fan harness plug for cleaning or maintenance procedures.

#### To lift the fan plenum:

1. Gently bend the bottom of the hinge pin arm away from the plenum to release the retainer from the coil support.
2. Rotate the hinge pin 180° so that the arm is pointed upwards.
3. Slide the hinge pin out and away from the plenum.



Lift up Fan Plenum. Use chain to hook up fan plenum to facilitate cleaning.

The plenum can also be removed, but this is not necessary for routine cleaning.

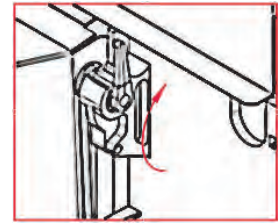
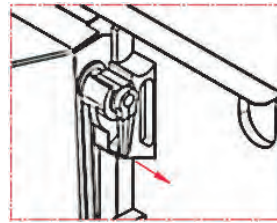

1. Flip the arm up and pull arm out to release the plenum.

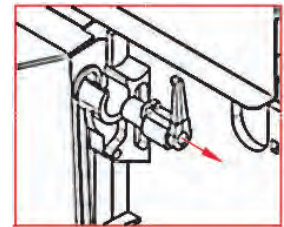

### Removable Return Air Grilles

The return air grilles may be removed to facilitate cleaning. Lift a four foot section up and out as shown below.

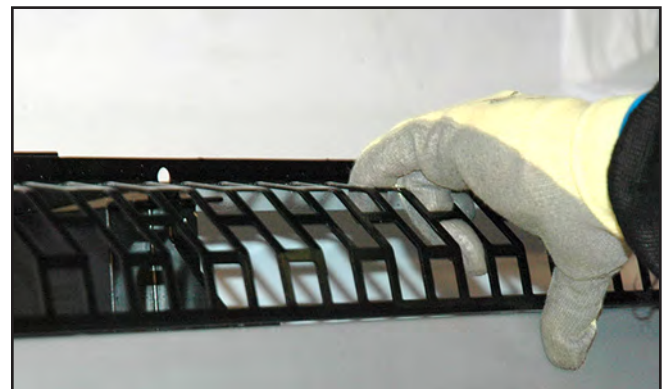

### **⚠ WARNING**

- » All case cleaning and maintenance procedures should be performed with the power disconnected at the breaker.

## 5-2 MAINTENANCE

### Fascia Panels

The exterior of the fascia panels should be cleaned with a mild detergent and warm water.

Do not use ammonia-based products to clean optional acrylic panels. Never use abrasive cleansers or scouring pads.

### Exterior Surfaces

The exterior surfaces must be cleaned with a mild detergent and warm water to protect and maintain their attractive finish.

**NEVER USE ABRASIVE CLEANERS OR SCOURING PADS.**

### Interior Surfaces

The interior surfaces may be cleaned with most domestic detergents, ammonia based cleaners and sanitizing solutions will not harm the surface.

Always read and follow the manufacturer's instructions when using any cleaning product.

Inspect all LED connections and plug/ receptacles for signs of arcing. Replace any component that shows signs of arcing. Make sure all unused receptacles have close-off covers securely attached.

### Do Not Use:

- Abrasive cleansers and scouring pads, as these will mar the finish.
- Coarse paper towels on coated glass.
- Ammonia-based cleaners on acrylic parts.
- Do not spray water from a hose directly on the canopy lights or fans.
- Solvent, oil or acidic based cleaners on any interior surfaces.

- A pressure nozzle on canopy lights, shelf lights or any other electrical connection. Do not use water pressure beyond what is supplied from the potable water system and spray nozzle (ie Do not use a pressure washer.)

### Steps:

- First turn off refrigeration, then disconnect electrical power. Shut off lights and fans. Make sure all unused light receptacles have their close-off covers securely attached.
- Remove the product and all loose debris to avoid clogging the waste outlet.
- Store product in a refrigerated area such as a cooler. Remove only as much product as can be taken to the cooler in a timely manner.
- Thoroughly clean all surfaces with soap and warm water. Do not use steam or high water pressure hoses to wash the interior. These will destroy the merchandisers' sealing causing leaks and poor performance.
- Lift hinged fan plenum for cleaning. Hook chain in rear panel to secure plenum during cleaning. Be sure to reposition the fan plenum after cleaning merchandiser.
- Take care to minimize direct contact between fan motors and cleaning or rinse water.
- Rinse with warm water, but do not flood. Never introduce water faster than the waste outlet can remove it.
- Allow merchandisers to dry before resuming operation.
- Wipe down lighted shelves with a damp sponge or cloth so that water does not enter the light channel.
- After cleaning is completed, turn on power to the merchandiser.

## RECOMMENDED CLEANING INSTRUCTIONS

The directions below are recommended cleaning instructions for Insight cases and should not be used as a substitute for the store's regular maintenance schedule. Follow all local and national health codes. Cleanliness of the case encourages long-lasting life of the equipment. This guide lists some of the key areas of the cases that require cleaning to help maintain the overall appearance and performance of the equipment and keep it free of debris. The cases may need additional cleaning, especially in high traffic areas, dusty areas and during unusually extended periods of use of the equipment.

Rotate the type of detergent and sanitizer used. For example, rotate the use of an ammonia based, a chlorine based and/or a peroxide based detergent and sanitizer to ensure micro-organisms do not become resistant to a single detergent or sanitizer.

### CLEANING INSTRUCTIONS

#### Weekly or Monthly

1. Remove product; store it in another case or suitable walk-in cooler.
2. Remove wire racks and bottom pans. Cleaning them in the case with warm water and a soap solution, then rinse and set aside. Flip up the fan plenum assembly to provide more room for cleaning in the case if necessary.
3. Turn OFF power to the fans.
4. Remove all loose debris and food particles that may clog drain. Check drain to make sure it is not clogged. Do not force items down drain, use the drain catch to remove debris and dispose.
5. Remove honeycomb and price display molding.

6. Clean all surfaces including shelves and honeycomb by spraying down water (preferably warm) and mild detergent. Use a brush or cleaner pad if necessary to aid in penetrating dirt.

7. Use mild soap and water to clean condensate pump and heated evaporation pan (if field installed).

8. Rinse all surfaces with water, then spray with a sanitizer. Rinse off sanitizer with clean water using a hose. Allow surfaces to air dry, since wiping would defeat the purpose of sanitizing.

9. Replace all internal parts carefully so that they seat properly. This is necessary for proper case operation.

10. Turn ON power to the fans.

11. Replace product.

### CLEANING INSTRUCTIONS

#### Quarterly or Semiannually

1. Remove product; store it in another case or suitable walk-in cooler.
2. Remove wire racks and bottom pans. Cleaning them in the case with warm water and a soap solution, then rinse and set aside. Flip up the fan plenum assembly to provide more room for cleaning in the case if necessary.
3. Turn OFF power to the fans.
4. Remove all loose debris and food particles that may clog drain. Check drain to make sure it is not clogged. Do not force items down drain, use the drain catch to remove debris and dispose.
5. Remove honeycomb and price display molding.

6. Clean all surfaces including shelves and honeycomb by spraying down water (preferably warm) and mild detergent. Use a brush or cleaner pad if necessary to aid in penetrating dirt.
7. Remove all the shelves and set aside then remove the back panels.
8. Clean the backside of the back panels in the case as you remove them.
9. Clean the newly exposed surfaces and the coil by spraying down with water (preferably warm) and a mild detergent solution.
10. Rinse the newly exposed surfaces and the coil with water then spray with a sanitizer. Allow surfaces to air-dry, since wiping would defeat the purpose of sanitizing.
11. Replace the back panels and shelves.
12. Rinse all surfaces with water, then spray with a sanitizer. Allow surfaces to air-dry since wiping would defeat the purpose of sanitizing.
13. Replace all remaining internal parts carefully so that they seat properly. This is necessary for proper case operation.
14. Turn ON power to the fans.
15. Replace product.

**⚠ WARNING**

- » Do not use mechanical devices or other means to accelerate the defrosting process.
- » Do not use electrical appliances inside the food storage compartments of the case(s).

### CLEANING HONEYCOMB ASSEMBLIES

Honeycombs should be cleaned every six months, or depending on store environment the honeycombs may need to be cleaned more often. Dirty honeycombs will cause cases to perform poorly.

The honeycombs may be cleaned with a vacuum cleaner. Soap and water may be used if all water is removed from the honeycomb cells before replacing. Be careful not to damage the honeycombs.

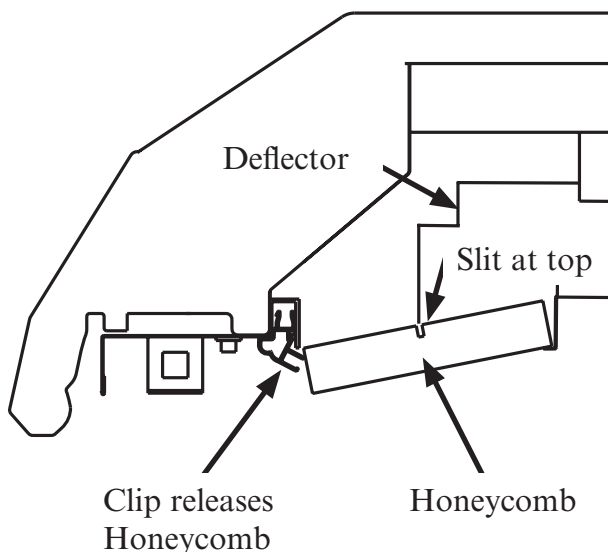

1. Remove honeycomb by pulling clip as shown above.
2. Clean and dry the honeycomb.
3. Honeycomb is symmetrical.
3. After cleaning, replace honeycomb. Ensure clip is centered and engaged along full-length of honeycomb.

***Damaged honeycomb must be replaced.***

## CLEANING MIRRORS

Mirrors are sheets of clear glass that have very thin reflective and protective coatings applied to one side. These coatings are susceptible to deterioration if certain cleaning solutions and even water are allowed to come in contact with them. Every precaution should be taken to keep all liquids away from the coated side of the mirrors. IF LIQUIDS ARE ALLOWED TO FLOW ALONG THE FACE SIDE OF THE MIRROR TO ITS EDGE, THE LIQUID CAN SEEP UP BETWEEN THE COATING AND THE GLASS, CAUSING SERIOUS DAMAGE.

### To Help Prolong the Life of the Mirrors:

- Use only mild cleaning solutions that do not leave residue, such as a weak (10%) solution of vinegar and water.
- Do NOT spray liquids on the mirrors. Away from food, dampen the cleaning cloth, then use the cloth to wipe the mirror.
- Wipe water from the mirrors immediately to prevent difficult to remove water spots and also to prevent the water from reaching the mirror's edge.
- Never use dirty cloths, scrapers or any other abrasive materials for cleaning.

### **▲WARNING**

- » Product will be degraded and may spoil if allowed to sit in a non-refrigerated area.
- » All products in the case should be removed and stored in a cooler at the appropriate temperature before cleaning the interior of the case.

## REMOVING INTERIOR BACK PANELS

The interior back panels may be removed for cleaning and to gain access to the evaporator coils. Remove the rear interior back panels as follows:

1. Disconnect the electrical power to the merchandiser.
2. Unplug shelf lights and insert plastic protective cap. Remove shelving.
3. Remove the lower panel first: lift the panel up, then pull forward and out.
4. Remove the top panel.



5. Replace panels in reverse order, starting with the top panel.

## 5-6 MAINTENANCE BOTTOM LINER REPAIR

Insight merchandisers have bottom liners, which are made of a high density polyethylene material (HDPE). Repairs may be made if the bottom liner becomes damaged. Follow the illustrations at right to repair the liner.

### *For minor repairs:*

Minor repairs consist of deep scratches and tears that are no more than  $\frac{1}{8}$  inch thick.

1.) Remove all product, and disconnect power to the case that is to be serviced. Locate the damaged area of the liner. Clear and clean the area, then wipe it dry.

2.) Use an electric hot air gun to heat the tear. **Heat to 600°F (316°C)**. Solder the tear with  $\frac{1}{8}$  inch filler welding rod, made from HDPE. Ensure no voids or skips in completed bead.

3.) Let the area cool, then buff the area flat. A 5-inch, 80 grit disc works well for this. The repair is now complete.

### *For major repairs:*

1.) For repairs with larger size gashes or holes, a piece of HDPE may be cut into a square as shown in **(F)** at right. (The square HDPE shown in the photo is white for clarity.)

2.) Remove all product and disconnect power to the case that is to be serviced. Locate the damaged area of the liner. Clear and clean the area, then wipe it dry. Ensure no voids or skips in completed bead.

3.) The square is then tacked at all four corners using the hot air gun.

4.) Solder with  $\frac{1}{8}$  inch filler welding rod around the perimeter of the HDPE square.

5.) Buff the area flat if needed. The repair is now complete.



Forthoff Mini Electric Hot Air Gun  
(120V 1300W)

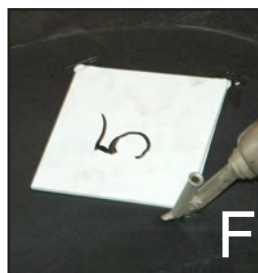
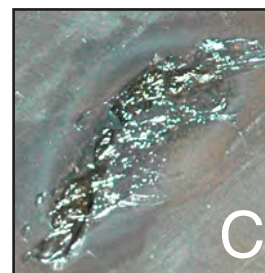
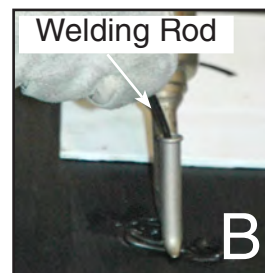
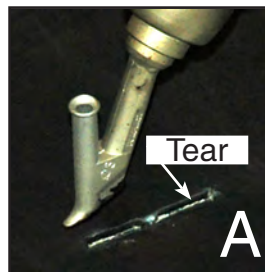

## ⚠ WARNING

- » Always wear protective clothing when operating hot air gun, such as fire resistant gloves and arm guards. Hot air gun operates at extremely high temperature and could cause serious burns. Always have fire protective gear on hand in case of fire.
- » To avoid serious injury or death from electrical shock, always disconnect the electrical power at the breaker when servicing or replacing any electrical component. This includes, but is not limited to, such items as doors, lights, fans, heaters, and thermostats.

## CLEANING COILS

### NEVER USE SHARP OBJECTS AROUND COILS!

Use a soft brush or vacuum brush to clean debris from coils. *Do not puncture coils!* Do not bend fins. Contact an authorized service technician if a coil is punctured, cracked or otherwise damaged.

**ICE** in or on the coil indicates the refrigeration and defrost cycle is not operating properly. Contact an authorized service technician to determine the cause of icing, and to make adjustments as necessary. To maintain product integrity, move all product to a cooler until the unit has returned to normal operating temperatures.

- Do NOT use chlorine or ammonia-based cleaners to clean aluminum coils.

## CLEANING STAINLESS STEEL FRONT RAILS

Use non-abrasive tools, and always polish with grain of the steel.

Use alkaline chlorinated or non-chlorine containing cleaners. Do not use cleaners containing salts as this may cause pitting and rusting of the stainless steel finish.

Clean frequently to avoid build-up of hard, stubborn stains. Rinse and wipe dry immediately after cleaning. Never use hydrochloric acid (muriatic acid) on stainless steel.

## REMOVING SCRATCHES FROM BUMPER

Most scratches and dings can be removed using the following procedure.

- Use steel wool to smooth out the surface area of the bumper.
- Clean area.
- Apply vinyl or car wax and polish surface for a smooth glossy finish.

## CLEANING UNDER MERCHANDISERS

Remove splashguards not sealed to floor. Use a vacuum with a long wand attachment to remove accumulated dust and debris from under the merchandiser.

### **WARNING**

- » Do not use HOT water on COLD glass surfaces. This can cause the glass to shatter and could result in personal injury. Allow glass fronts, ends and service doors to warm before applying hot water.

## CLEANING CONDENSATE PUMP AND HEATED EVAPORATION PANS

(for case with field-installed option)

ALWAYS DISCONNECT POWER AT THE MAIN CASE DISCONNECT BEFORE SERVICING THE EQUIPMENT.

These items are optional items and are not provided with the case.

- The condensate water outlet for the self-contained models empties into a limited capacity evaporation pan.
- Clean product spills immediately. If a product spill enters the Condensate Pump or Heated Evaporation Pans, a maintenance technician may be required to clean both the pump and heated pans.
- Clean case interior with a sponge or soft cloth, wetted with mild soap and water. Do not pour water from a bucket or hose into case drain. Water introduced during cleaning will cause the evaporation pan to overflow.
- Sediment and debris will clog the Condensate Pump and plastic tubing for water delivery to the Heated Evaporation Pans.
- The Condensate Pump and the Heated Evaporation Pans require regular monthly inspection. The Condensate Pump is located below the case bottom. The Heated Evaporation Pans are located on the case top. Evidence of excess water or odor is an indication that immediate service is required.
- Recommended cleaning the Condensate Pump reservoir and Heated Evaporation Pans is with mild soap and water. Disconnect power before cleaning. Empty pump sump and heater pans of water before reapplying power.

- If using the optional Defrost Synchronization controls, the Master Sync Switch needs to be reset by the maintenance technician after re-applying electrical power to case.

### **WARNING**

— LOCK OUT / TAG OUT —

- » To avoid serious injury or death from electrical shock, always disconnect the electrical power at the main disconnect when servicing or replacing any electrical component. This includes, but is not limited to, such items as doors, lights, fans, heaters, and thermostats.

### **WARNING**

» — Evaporation Pan is Hot!—

- » and poses risk of bodily injury — Always wear gloves and protective eye wear when servicing condensate pump and heated evaporation pans. Turn off evaporation pan heater, and allow pan to cool before servicing.

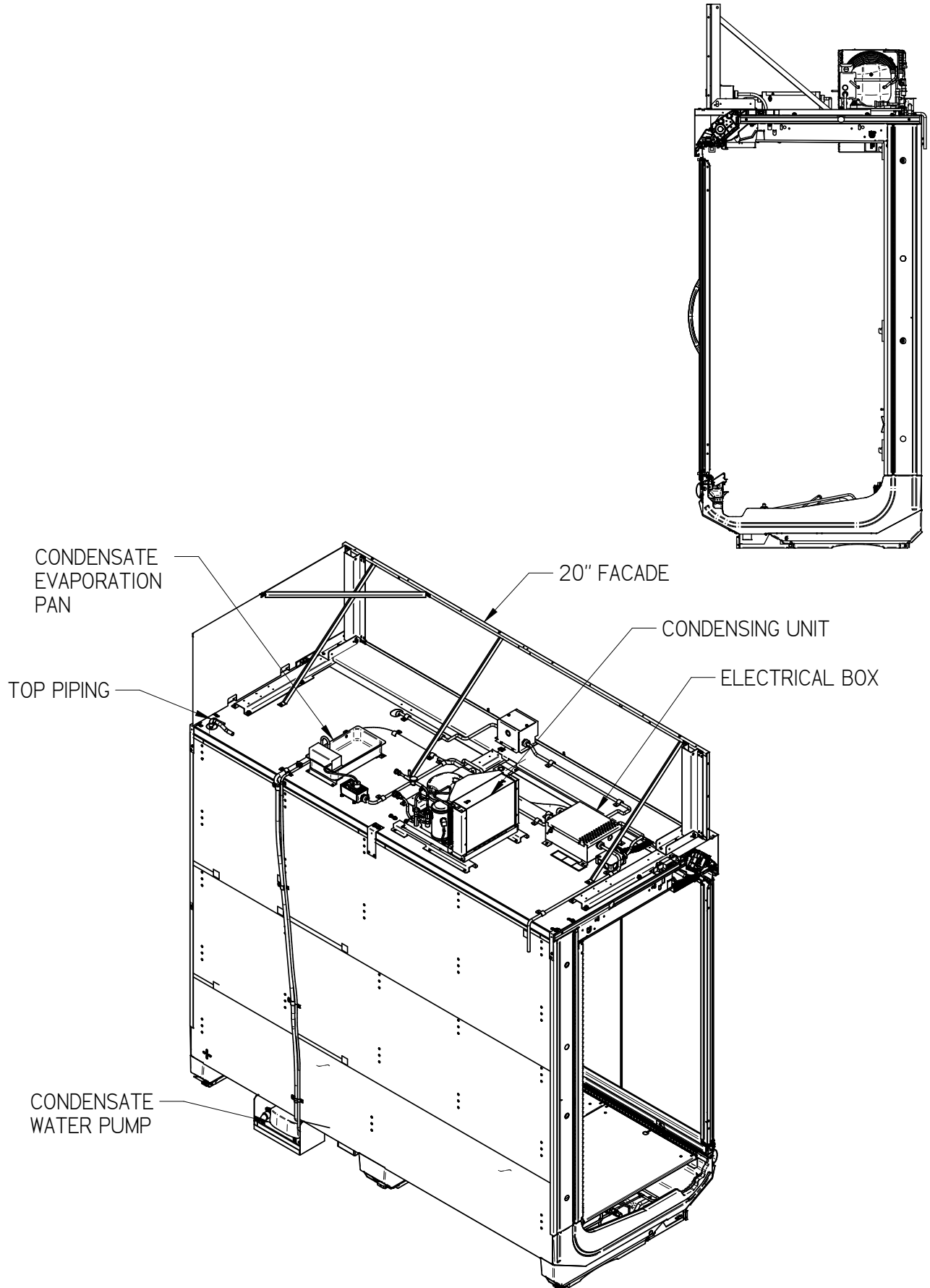

(8FT CASE SHOWN)

## SERVICE

### REPLACING FAN MOTORS

See Appendix for separate fan motor replacement instructions if motor harness connector is different than the one shown below.

Should it ever be necessary to service or replace the fan motors or blades, be certain that the fan blades are reinstalled correctly.

To access and replace fan motor:

1. Turn off case power at breaker.
2. Remove bottom display pans.
3. Unpack new motor/harness assembly and set aside outside of case.
4. Remove screws holding existing fan motor bracket assembly to plenum, and remove assembly from plenum.
5. Disengage and unplug existing motor harness connector; remove existing motor.
  - A. Grasp the plug and receptacle, and apply slight pressure to pull apart. The connector should not separate without depressing the locking tab.
6. Taking care to avoid any existing moisture in the case, IMMEDIATELY connect and lock new motor harness as follows:
  - A. Align the plug and receptacle, and push together until the locking tab engages. (Locking tab must engage in the window of receptacle and not separate.)

Locking  
Tab



Locking  
Tab



Window

### **⚠ WARNING**

— LOCK OUT / TAG OUT —

- » To avoid serious injury or death from electrical shock, always disconnect the electrical power at the main disconnect when servicing or replacing any electrical component. This includes, but is not limited to, such items as doors, lights, fans, heaters, and thermostats.

## 6-2 SERVICE

7. Place new fan motor assembly back into plenum, and reinstall screws to secure.

8. Turn on power.

9. Verify that motor is working and blade is turning in the correct direction.

10. Close air gaps under fan plenum. Warmer air moving into refrigerated air reduces effective cooling. If the plenum does not rest against the case bottom without gaps, apply foam tape to the bottom of the fan plenum to reduce improper air movement. Use silicone sealant to close other gaps.

11. Replace display pans. Bring merchandiser to operating temperature before restocking.



### **! WARNING**

#### **» STOP - DO NOT UNPLUG**

- » The fan motor harness plug **MUST** be properly secured in order to perform at its IP68 rating. This connection should **ONLY** be disconnected / connected by a qualified contractor and **ONLY** in the event of a fan motor replacement. The fan motor harness plug should not be disconnected/connected in performing any other cleaning, service or repair. Refer to the installation, operation and services manual for sequence of repair. All case cleaning & maintenance procedures should be performed with the power disconnected at the breaker. Failure to adhere to these instructions can lead to damage to the unit and creates a risk of flammability.

**DOORS  
(INSTALLING, REMOVING, ADJUSTING)**

**A.** To install a door:  
Lean door back, and push pin into mullion.  
Ensure push pins are fully seated in canopy support bracket.

**B.** To remove a door:  
Raise door up and lift rod bottom out of bottom hinge plate hole

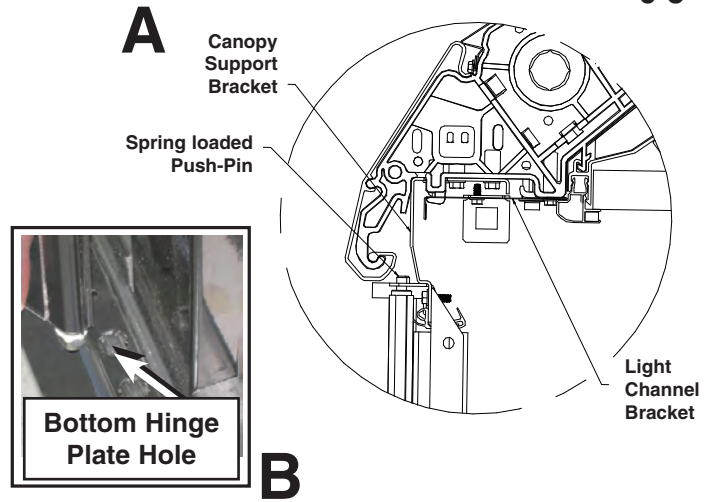

**ADJUSTING ECOVISION DOORS**

Check that all doors open and close properly.

Excessive ambient conditions may cause condensation and therefore sweating of doors. Facility operators should monitor doors and floor conditions to ensure safety of persons.

**A.** Leveling — Merchandisers must be installed level to ensure proper operation of the refrigeration system, and to ensure proper drainage of defrost water.

**B.** Door Adjustment — Loosen the screws A, B and C as shown below (Do not remove the screws completely).

Glass alignment is also affected with improper leveling of the merchandisers. All steps of setting joining and case leveling attention to the glass position is critical. Do not attempt to make glass adjustments prior to case leveling.

Slide the bottom plate left and right until proper alignment is achieved. Retighten the screws A, B and C. Install fasteners in locations 1 and 2 as shown below.

**EcoVision Door Alignment - Modular Bottom Hinge Plate**

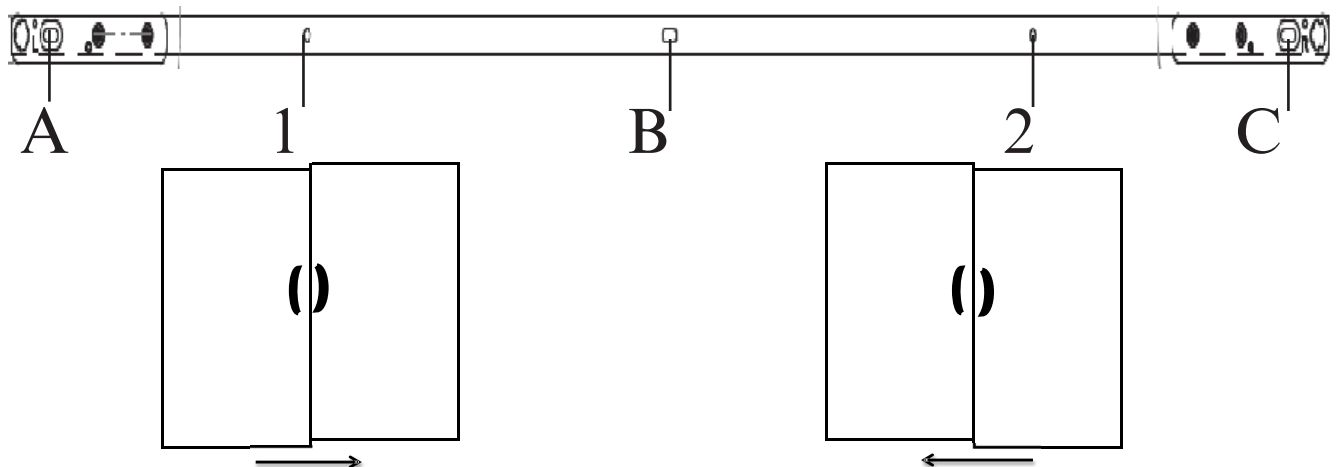

To Correct Shift the Bottom Plate to the Right

To Correct Shift the Bottom Plate to the Left

**ADJUSTING DOOR CLOSING SPEED**

The door's closing speed is factory adjusted, but the door may also be field adjusted.

Do the following to adjust the doors:

1. To release door tension, open the door to 90° and lift up the door from the bottom. Lift the torsion rod out of the star pattern in the bottom hinge plate. (The door should be lifted out of the star pattern in the hinge plate to prevent any damage to the star pattern.)
2. Use a ½ in. open end wrench to tighten the torsion of the door. Adjust tension with each audible click. Doors should be adjusted to 4 clicks, more if needed. Door must be properly resealed in star pattern of hinge plate after torsion tension is applied.

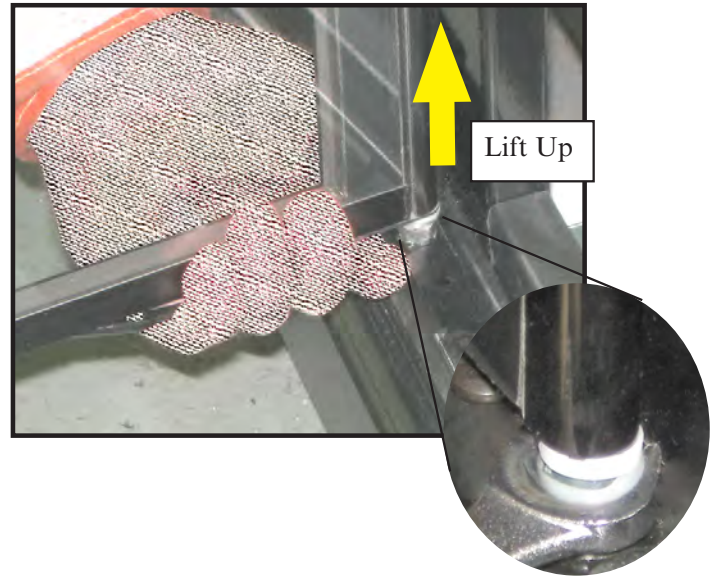

## REPLACING LED CANOPY LIGHT BARS

LED canopy lights come standard for Insight merchandisers and Insight merchandisers with EcoVision II Doors. Canopy lights are powered by a 24 VDC power supply. The power supply(s) are located in the case canopy behind fascia panels.

The canopy light bars are attached to the canopy light channel with mounting clips. The electrical wiring has a quick connect that can be unplugged.

1. To replace a canopy light bar, carefully remove the light bar from the clip, replace with like Hussmann fixture, and connect the new wiring to the quick connect.
2. Return power, and switch the light switch on and off to ensure lights work properly.



Canopy Light Bar

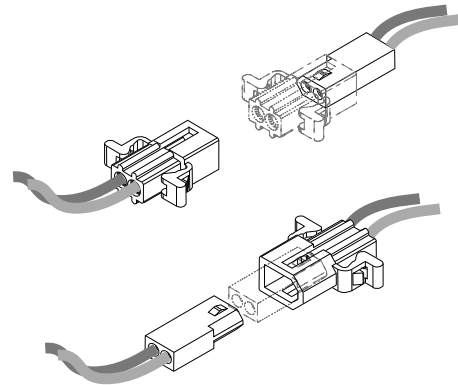

Canopy Light Connector

## REPLACING LED SHELF LIGHT BARS

The LED shelf light bars are held in place using a clip on the back of the light bar. Shelf light bars are powered by 24 VDC Class 2 power supply located in the case canopy, behind the fascia panel.

1. Turn OFF the light switch in the case canopy. Ensure power is turned off to the case. Unplug the shelf wire connector from the receptacle where it is plugged.
2. Replace with the appropriate Hussmann LED light bar.
3. Return power, and switch the light switch on and off to ensure lights work properly.



Shelf Light Bar

See Page 4-6 for more information about installing shelf lights.

## REPLACING LED VERTICAL MULLION LIGHT BARS

LED vertical mullion lights are an available lighting option for EcoVision II doors. Center fixtures illuminate the middle of the case, and the end fixtures illuminate the ends, or sides of the case.

LEDs should not be interchanged. Contact your Hussmann representative to order replacements.

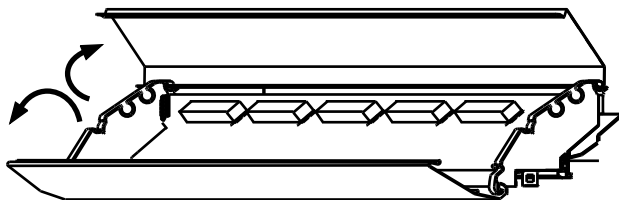
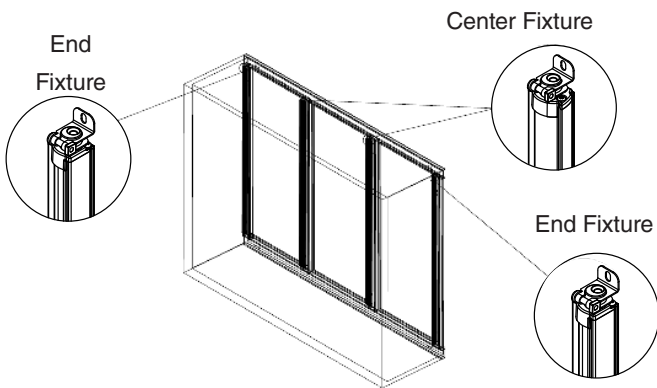

Power Supply(s) inside Wireway

## REPLACING LED POWER SUPPLIES

Replacing electrical components should only be performed by a qualified service technician. The 24 VDC power supplies for the LEDs are located at the top of the merchandiser inside the canopy.

1. **DISCONNECT POWER TO THE MERCHANDISER.**
2. Flip canopy fascia panel out to find the power supply(s) in the wireway behind canopy panel.
3. Remove the screws that secure the power supply(s), and disconnect the LED wiring at the quick connects.
4. Remove the old power supply, and install new power supply. Replace parts in reverse order. All connections must be made in the wireway.
5. Reconnect the electrical power. Turn on light switch on and off to ensure lights work properly.



**24VDC power supplies must be replaced with Class 2 Hussmann power supply to ensure proper operation. Contact your Hussmann representative to order replacement kits.**

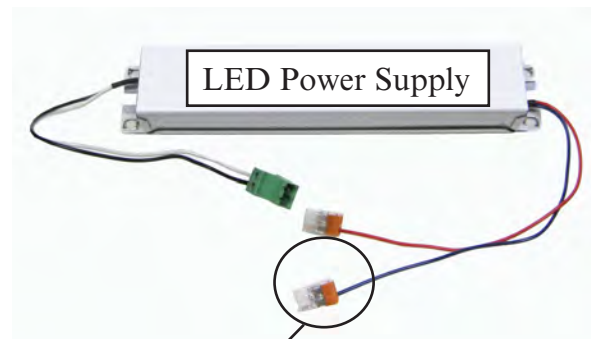

Quick Connect

## REPLACING DOOR HANDLES

These doors have glued on studs. If the handle is broken it should be replaced along with the stud.

1. Use a razor blade to remove the excess glue from the door. Only replace the stud that is damaged.
2. Clean the glass surface. Apply isopropyl alcohol to the surface of the glass and wipe using a paper towel until dry.
3. Clean the surface of the stud. Apply isopropyl alcohol to the surface to the stud and wipe using a paper towel until dry.
4. Apply Loctite SF 7387 to the bottom flat surface of the stud and wait 30 seconds or until dry.

### Tools and Supplies Needed:

EcoVision Stud: P/N 3119359

Glue: Loctite AA 392

Activator: Loctite SF 7387

Razor

Hammer, if needed

Template

Isopropyl Alcohol

Paper Towels

Tape

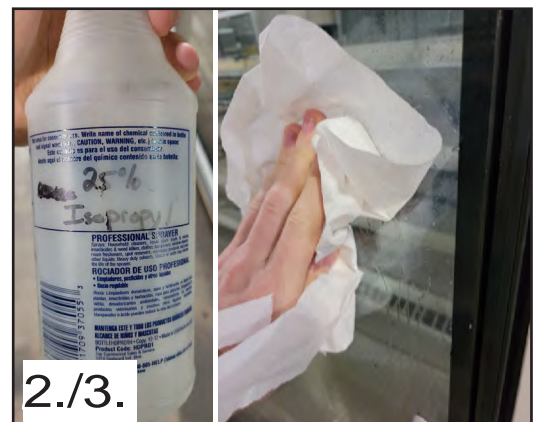

## 6-8 SERVICE

5. Place the stud template in the correct orientation/location and secure to surface of the door.

Ensure tape does not leave residue when removed. Painter's tape and 3M 8898 are the suggested choice of tape to use.

6. Apply a drop of Loctite AA 392 to the center of the stud.

7. By hand, firmly press the stud to the glass for 15 seconds.



- 8. Carefully remove the stud template from the door and wait 5 minutes to allow the glue to cure fully.
- 9. Carefully wipe away any excess glue / activator from glass surface and clean using isopropyl alcohol.

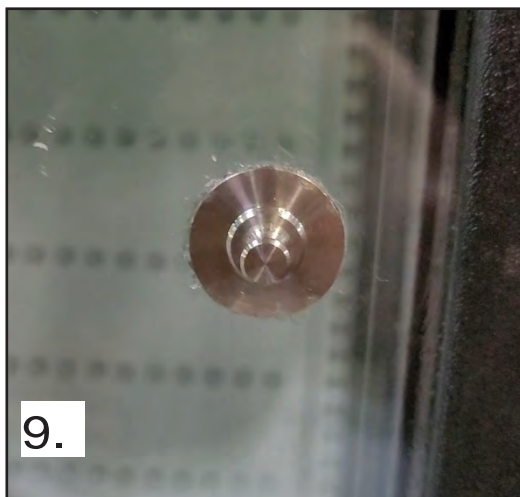

**REPAIRING ALUMINUM COIL**

The aluminum coils used in Hussmann Insight merchandisers may be easily repaired in the field. Materials are available from local refrigeration wholesalers.

Hussmann recommends the following solders and technique:

**Solders**

Aladdin Welding Products Inc.  
P.O. Box 7188  
1300 Burton St.  
Grand Rapids, MI 49507  
Phone: 1-800-645-3413  
Fax: 1-800-645-3414

X-Ergon  
1570 E. Northgate  
P.O. Box 2102  
Irving, TX 75062  
Phone: 1-800-527-9916

**NOTE:**

Hussmann Aluminum melts at 1125°F (607°C)  
Aladdin 3-in-1 rod at 732°F (389°C)  
X-Ergon Acid core at 455°F (235°C)

**Technique:**

1. Locate Leak.
2. REMOVE ALL PRESSURE.
3. Brush area UNDER HEAT.
4. Use PRESTOLITE TORCH ONLY. Number 6 tip.
5. Maintain separate set of stainless steel brushes and USE ONLY ON ALUMINUM.
6. Tin surface around area.
7. Brush tinned surface UNDER HEAT, thoroughly filling the open pores around leak.
8. Repair leak. Let aluminum melt solder, NOT the torch.
9. Don't repair for looks. Go for thickness.
10. Perform a leak check.
11. Wash with water.
12. Cover with a good flexible sealant.

# HUSSMANN<sup>®</sup>

To obtain warranty information or other support, contact your Hussmann representative or visit:  
<https://www.hussmann.com/services/warranty>.

Please include the model and serial number of the product.

For questions about your equipment please contact our Technical Support Team 866-785-8499

For General Support or Service Calls contact our Customer Support Call Center 800-922-1919

For ordering Aftermarket Warranty Parts 1-855-Huss-Prt (1-855-487-7778)  
[Hussmann\\_part\\_warranty@hussmann.com](mailto:Hussmann_part_warranty@hussmann.com)

## APPENDIX

### REPLACING FAN MOTORS

(For fan motors with locking harness connector)

Fan control electronics are electrostatic sensitive (ESD). If the case is equipped with an optional fan speed selector (FSS), use a grounding kit before handling.

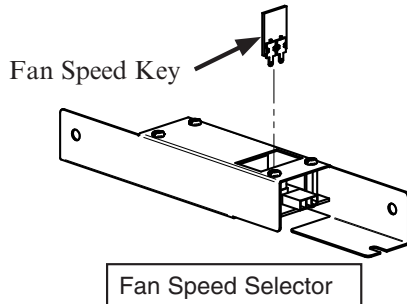

### WARNING

— LOCK OUT / TAG OUT —

» To avoid serious injury or death from electrical shock, always disconnect the electrical power at the main disconnect when servicing or replacing any electrical component. This includes, but is not limited to, such items as doors, lights, fans, heaters, and thermostats.

See cross section for location of evaporator fans. Should it ever be necessary to service or replace the fan motors or blades be certain that the fan blades are re-installed correctly.

To access and replace fan motor:

1. Turn off case power at breaker.
2. Remove bottom display pans.
3. Unpack new motor/harness assembly and set aside outside of case.
4. Remove screws holding existing fan motor bracket assembly to plenum, and remove assembly from plenum.
5. Unlock and Unplug existing motor harness from harness; remove existing motor.
  - A. Rotate locking ring counterclockwise to unlock.
  - B. Pull connector straight out to disengage.
6. Taking care to avoid any existing moisture in the case, IMMEDIATELY connect and lock new motor harness as follows:



#### Correct connection procedure for main fan motor harness connector:

- A. Align arrows and push connector into position.
- B. Rotate locking ring until all three arrows are aligned in the secured position.

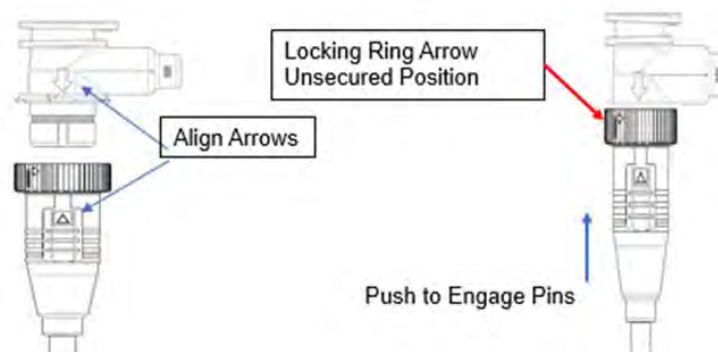

C. Push straight in to engage pins.

D. Turn locking ring until all three arrows are aligned.

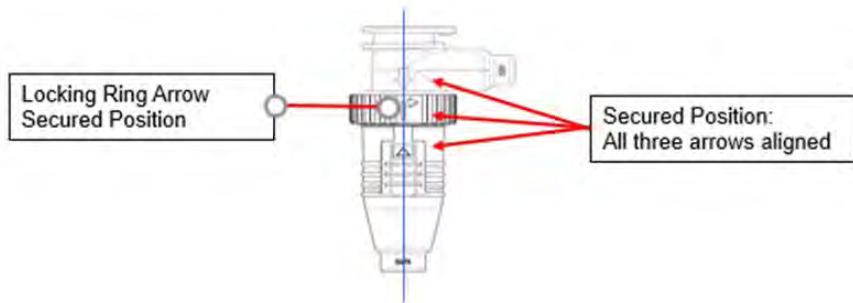

Remember. Push to engage, then twist to secure.

## **⚠ WARNING**

### **STOP - DO NOT UNPLUG**

The fan motor harness plug **MUST** be properly secured in order to perform at its IP67 rating. The component is a twist lock style connector with an alignment arrow to validate a secure connection. This connection should **ONLY** be disconnected / connected by a qualified contractor and **ONLY** in the event of a fan motor replacement. The fan motor harness plug should not be disconnected/connected in performing any other cleaning, service or repair. Refer to the installation, operation and services manual for sequence of repair. All case cleaning & maintenance procedures should be performed with the power disconnected at the breaker. Failure to adhere to these instructions can lead to damage to the unit and creates a risk of flammability.

7. Place new fan motor assembly back into plenum, and reinstall screws to secure.
8. Turn on power.
9. Verify that motor is working and blade is turning in the correct direction.
10. Close air gaps under fan plenum. Warmer air moving into refrigerated air reduces effective cooling. If the plenum does not rest against the case bottom without gaps, apply foam tape to the bottom of the fan plenum to reduce improper air movement. Use silicone sealant to close other gaps.
11. Replace display pans. Bring merchandiser to operating temperature before restocking.