



Installation, Operation, and Service Manual

Insight® Single and Multideck Medium Temperature Remote Display Cases

P/N 0535974 Rev Y
February 2026

Models Covered

All remote Insight case model numbers beginning with IC, ID, IM, and IP excluding self-contained and wedge cases.

Certifications



WARNING:

If the information in these instructions are not followed exactly, a fire or explosion may result, causing property damage, personal injury, or death. Installation and service must be performed by a qualified installer or service agency.

READ THE ENTIRE MANUAL BEFORE INSTALLING OR USING THIS EQUIPMENT.

The equipment can be configured to use a variety of refrigerants during the ordering process. Different refrigerants have unique characteristics to be aware of, including the mild flammability of A2L refrigerants and potential toxicity of R-744 (CO₂) in high concentrations. If a leak is present or suspected, do not allow untrained personnel to attempt to find the cause and observe all warnings contained within this document. No open flames, cigarettes, or other possible sources of ignition should be used inside or in the vicinity of equipment containing flammable refrigerants.

Equipment is limited to use in an altitude of 6,562 ft (2 km) or less.

FAILURE TO ABIDE BY THIS WARNING COULD RESULT IN AN EXPLOSION, DEATH, INJURY, AND PROPERTY DAMAGE.

We reserve the right to change or revise specifications and product design in connection with any feature of our products. Such changes do not entitle the buyer to corresponding changes, improvements, additions or replacements for equipment previously sold or shipped.

Insight® Single and Multideck

Table of Contents

User Safety and Product Information	3	Electrical Access for Sign-Ready & Flat-Front	
Legal Disclaimer	3	Fascias	89
ANSI Z535.5 Definitions	3	Lighting	90
Proposition 65	3	LED Mullion Light Bars	90
Serial Label Location	4	Refrigerant Charging Procedure	91
ETL Listing	4	Pumped Liquid R-744 (CO ₂) Start-Up Checklist	92
NSF Listing	4	Pumped Liquid R-744 (CO ₂) Operation	93
Climate Class and Ambient Conditions	4	Multiple Restart and Lockout Procedure	94
Federal / State Regulation	4	Thermostatic Expansion Valve (TXV) Adjustment	95
Additional Important Symbols	4	Safety Shut-Off Valves (A2L only)	95
General Safety Instructions	5	Pumped Liquid R-744 (CO ₂) Case Inlet	
Before Working with All Refrigerant Types	6	Solenoid Valve	96
Before Working with R-744 (CO ₂) Refrigerant	9	Panel, Bumper, and Guard Installation	97
Before Working with A2L Refrigerant	15	Installing Bumpers	105
A2L Refrigerant Detection System Overview	17	Shelf Installation	106
Splashguard Fans for A2L-Equipped Models	18	Load Limits	109
Cautions	18	Installing CaseShieldPTM(s) (Optional)	110
Model Description	18	Maintenance and Service	111
Husmann Product Control	18	Checks and Repairs for A2L Equipment	111
Installation Information	19	Checks and Repairs for R-744 (CO ₂) Equipped Equipment	112
Equipment Inspection / Shipping Damage	19	Checks and Repairs for All Equipment	112
Unloading, Moving, and Transporting Case Location	19	Care and Cleaning	113
Minimum Room Floor Area (A2L only)	20	Troubleshooting	119
End Shipping Braces	25	Refrigerant Removal, Evacuation, and Recovery	120
Shipping Rider	25	Leak Detection (all refrigerants)	121
Leveling Case	25	A2L Leak Detection Sensor Service and Mitigation	122
Case Joining	26	Component Replacement	129
Sealing Lineup Joints (all cases)	41	Replacing Door Handles	131
Installing End Assemblies	49	Decommissioning	134
Installing Partitions	54	Decommissioning Process	134
Installing Night Blinds	67	Warranty	135
Troubleshooting Night Blinds	70	Revision History	135
Doors - Installing, Removing, Adjusting	71		
Adjusting Door Closing Speed	72		
Piping Overview	73		
CO ₂ Piping	73		
Additional Piping Installation Requirements	75		
Line Connection Sizes	76		
Waste Outlet/Drain Line	76		
Refrigerant Piping	76		
Waste Outlet / Drain Line	80		
Electrical Information	86		
Field Wiring	86		
Defrost Sequences	87		
Control Sensor Location	88		

Insight® Single and Multideck

User Safety and Product Information

Legal Disclaimer

Review all safety warnings on the case and in this manual before attempting start-up. Hussmann shall not be liable for any repair or replacement made without the written consent of Hussmann, or when the product is installed or operated in a manner contrary to the printed instructions covering installation and service which accompanied such product. Please note that failure to follow the instructions in this document may void your factory warranty.

As used herein, “appliance”, “unit”, and “equipment” each refer to case family/name unless otherwise stated or contextualized and “system” means a set of things working together as parts of an interconnecting network.

ANSI Z535.5 Definitions

The definitions below are used to clarify the magnitude and urgency of harm and damage, considering problems arising from misuse. Relative to their potential danger, the definitions are divided into five parts according to ANSI Z535 Series.



DANGER indicates a hazardous situation which, if not avoided, will result in death or serious injury.



WARNING indicates a hazardous situation which, if not avoided, could result in death or serious injury.



CAUTION indicates a hazardous situation which, if not avoided, could result in minor or moderate injury.



NOTICE is used to address practices not related to personal injury.



SAFETY INSTRUCTIONS (or equivalent) signs indicate specific safety-related instructions or procedures.

Proposition 65



This warning does not mean that Hussmann products will cause cancer or reproductive harm, or is in violation of any product-safety standards or requirements. As clarified by the California State Government, Proposition 65 can be considered more of a ‘right-to-know’ law than a pure product safety law. When used as designed, Hussmann believes that our products are not harmful. We provide the Proposition 65 warning to stay in compliance with California State law. It is your responsibility to provide accurate Proposition 65 warning labels to your customers when necessary. For more information on Proposition 65, please visit the California State Government website.

Insight® Single and Multideck

User Safety and Product Information

Serial Label Location

Serial plates are located on the left side, facing the case. The serial plate contains information about the specific model and its operating parameters. A serial plate for multideck cases is also located behind the return air grille in the same location as single-deck cases (shown below). Serial label contains all pertinent information such as model, serial number, amperage rating, refrigerant type, and other important installation and safety information.



ETL Listing

These merchandisers are manufactured to meet ANSI / UL 60335-2-89 and CSA C22.2 standard requirements for safety. Proper installation is required to maintain this listing. This appliance is to be installed in accordance with the Safety Standard for Refrigeration Systems, ANSI/ASHRAE 15.

NSF Listing

These merchandisers are manufactured to meet ANSI / NSF-7 standard requirements for sanitation. Proper installation is required to maintain this listing. If required by local sanitation codes, or if desired by the customer, plastic splashguards may be sealed to the floor using silicone type sealer.

Climate Class and Ambient Conditions

The test room climate class for this appliance is Climate Class 8. Climate Class 8 means the equipment has been tested for maximum ambient of 75° F (23.9° C) dry bulb and 55% relative humidity.

Ambient conditions that equipment is designed for may exceed 75° F (23.9° C) and 55% relative humidity in some cases. Consult the labeling on the equipment for the maximum ambient temperature and humidity in which the equipment can be installed. Do not exceed the listed ambient conditions.

Federal / State Regulation

These merchandisers, at the time they are manufactured, meet all federal and state/provincial regulations. Proper installation is required to ensure these standards are maintained. Near the serial label, each case carries a label identifying the environment (temperature and relative humidity) in which the case was designed to be used.

Additional Important Symbols

The symbols below indicate specific types of information on the equipment.



Risk of fire due to flammable material and/or refrigerant being present



Minimum Room Floor Area



High Pressure



Grounding Connection Location

Insight® Single and Multideck

User Safety and Product Information

General Safety Instructions

SAFETY INSTRUCTIONS

This manual was written in accordance with originally prescribed equipment that is subject to change. Hussmann reserves the right to change or revise specifications and product design in connection with any feature of our products.

Personal Protection Equipment (PPE) is required. Wear safety glasses, gloves, protective boots or shoes, long pants, and a long-sleeve shirt when working with this equipment and while handling glass.



The safety of our customers and employees is paramount. The precautions and procedures described in this manual are intended as general methods for safe use of this equipment. Please be sure to comply with the precautions described in this manual to protect you and others from possible harm. Always follow OSHA standards for safety.

Only qualified personnel should install and service this equipment. Personal Protection Equipment (PPE) is required. Wear safety glasses, gloves, protective boots or shoes, long pants, and a long-sleeve shirt when working with this equipment and while handling glass.

Observe the refrigerant type the equipment is designed to work with and any and all precautions on tags, stickers, labels and literature provided and referenced for this equipment. Use only Hussmann approved parts approved through the Hussmann Performance Parts Website. Verify that all repair parts are identical models to the ones they are replacing. Do not substitute parts such as motors, switches, relays, heaters, compressors, power supplies, or solenoids. Read all safety information regarding the safe handling of refrigerant and refrigerant oil, including the Material Safety Data Sheet. MSDS sheets can be obtained from your refrigerant supplier. Service is to be performed by factory-authorized service personnel, so as to minimize the risk of possible injury due to incorrect parts or improper service.

Contractors must strictly adhere to specifications provided by the Engineer of Record (EOR), as well as US EPA regulations, OSHA regulations, and all other federal, state, and local codes. There are numerous hazards, not limited to, but including: burns due to high temperatures or refrigerant flammability, high pressures, toxic substances, electrical arcs and shocks, very heavy equipment with specific lift points and structural constraints, public safety, noise, and possible environmental damage.

Insight® Single and Multideck

User Safety and Product Information

WARNING

Before Working with All Refrigerant Types

The following apply to ALL REFRIGERANT TYPES. Refrigerant specific warnings and safety information are present in the following sections. Do not attempt to install, service, or perform maintenance on any equipment without reading and understanding ALL applicable warnings related to the equipment.

READ THE ENTIRE MANUAL AND ALL WARNINGS BEFORE INSTALLING OR USING THIS EQUIPMENT.

- Installation and use of this appliance includes numerous hazards, not limited to, but including: burns due to high temperatures, high pressures, toxic substances, electrical arcs and shocks, very heavy equipment with specific lift points and structural constraints, food and product damage or contamination, public safety, noise, and possible environmental damage.
- This appliance shall only be connected to another appliance suitable for the same refrigerant.
- Be aware that refrigerants may not contain an odour.
- Excessive ambient conditions may cause condensation and sweating on doors. Facility operators are responsible for monitoring doors and floor conditions and ensuring the safety of all persons present. Installation and service must be performed by a qualified installer or service agency only as recommended by the manufacturer.
- If a leak is present or even suspected, do not allow untrained personnel to attempt to find the cause.
- A hand-held leak detector (“sniffer”) will be used before any repair and/or maintenance.
- **WARNING:** Keep clear of obstruction, all ventilation openings in the appliance enclosure or in the structure for build-in.
- **WARNING:** Do not use mechanical devices or other means to accelerate the defrosting process, other than those recommended by the manufacturer.
- **WARNING:** Do not damage the refrigerating circuit.
- **WARNING:** Do not use electrical appliances inside the food/ice storage compartments unless they are the type recommended by the manufacturer.
- Do not use any means to clean, other than those recommended by the manufacturer.
- Do not use means to accelerate the defrosting process or to clean, other than those recommended by the manufacturer.
- The appliance shall be stored in a room without continuously operating ignition sources (for example: open flames, an operating gas appliance or an operating electric heater).
- Do not pierce or burn refrigerant piping.
- Do not store items or flammable materials atop the unit. Do not walk on case.
- Do not store explosive substances, such as aerosol cans with flammable propellant, in this appliance.
- This appliance is not intended for use by persons (including children) with reduced physical, sensory or mental capabilities, or lack of experience and knowledge, unless they have been given supervision or instruction concerning use of the appliance by a person responsible for their safety.
- Children should be supervised to ensure that they do not play with the appliance.

Insight® Single and Multideck

User Safety and Product Information

WARNING

- Check that cabling will not be subject to wear, corrosion, excessive pressure, vibration, sharp edges, or any other adverse environmental effects. The check shall also take into account the effects of aging or continual vibration from sources such as compressors or fans.
- Any insulation shall be suitable for use with the material being insulated.
- Protection devices, piping, and fittings shall be protected as far as possible against adverse environmental effects, for example, the danger of water collecting and freezing in relief pipes or the accumulation of dirt and debris.
- Piping material, pipe routing, and installation shall include protection from physical damage in operation and service, and be in compliance with national and local codes and standards, such as ANSI/ASHRAE 15, IAPMO Uniform Mechanical Code, ICC International Mechanical Code, or CSA B52. All field joints shall be accessible for inspection prior to being covered or enclosed. Mechanical connections made in accordance shall be accessible for maintenance purposes.
- The installation of pipe-work shall be kept to a minimum.
- Provision shall be made for expansion and contraction of long runs of piping.
- Piping in refrigeration systems shall be so designed and installed to minimize the likelihood of hydraulic shock damaging the system.
- Flexible pipe elements shall be protected against mechanical damage, excessive stress by torsion, or other forces, and that they should be checked for mechanical damage annually.
- Precautions shall be taken to avoid excessive vibration or pulsation of the refrigerant piping.
- LOCK OUT / TAG OUT — To avoid serious injury or death from electrical shock, always disconnect the electrical power at the main disconnect when servicing or replacing any electrical component. This includes, but is not limited to, such items as doors, lights, fans, heaters, and thermostats.
- To reduce the risk of fire, electrical shock or injury when cleaning this merchandiser:
 - Unplug the merchandiser before cleaning.
 - Keep all liquids away from electrical and electronic components.
- Merchandiser must be grounded. All wiring must be in compliance with NEC and local codes.
- The appliance shall not be installed in public corridors or lobbies.
- All servicing of this appliance shall be performed only as recommended in this manual.
- Particular attention shall be paid to the following to ensure that by working on electrical components, the casing is not altered in such a way that the level of protection is affected. This shall include damage to cables, excessive number of connections, terminals not made to original specification, damage to seals, incorrect fitting of glands, etc.
- Ensure that the apparatus is mounted securely.
- Ensure that seals or sealing materials have not degraded to the point that they no longer serve the purpose of preventing the ingress of flammable atmospheres. Replacement parts shall be in accordance with the manufacturer's specifications.

Insight® Single and Multideck

User Safety and Product Information

WARNING

- Where electrical components are being changed, they shall be fit for the purpose and to the correct specification. At all times, the manufacturer's maintenance and service guidelines shall be followed. If in doubt, consult the manufacturer's technical department for assistance.
- During repairs to sealed components, all electrical supplies shall be disconnected from the equipment being worked upon prior to any removal of sealed covers, etc. If it is absolutely necessary to have an electrical supply to equipment during servicing, then a permanently operating form of leak detection shall be located at the most critical point to warn of a potentially hazardous situation.
- Component parts shall be replaced with like components, and servicing shall be done by qualified service personnel only.
- Do not apply any permanent inductive or capacitance loads to the circuit without ensuring that this will not exceed the permissible voltage and current permitted for the equipment in use.
- After completion of field piping for split systems, the field pipework shall be pressure tested with an inert gas and then vacuum tested prior to refrigerant charging, according to the following requirements:
 1. The minimum test pressure for the low side of the system shall be the low side design pressure and the minimum test pressure for the high side of the system shall be the high side design pressure, unless the high side of the system cannot be isolated from the low side of the system in which case the entire system shall be pressure tested to the low side design pressure.
 2. The test pressure after removal of pressure source shall be maintained for at least 1 hour with no decrease of pressure indicated by the test gauge, with test gauge resolution not exceeding 5% of the test pressure.
 3. During the evacuation test, after achieving a vacuum level specified in the manual or less, the refrigeration system shall be isolated from the vacuum pump and the pressure shall not rise above 1,500 microns within 10 min. The vacuum pressure level shall be specified in the manual, and shall be the lessor of 500 microns or the value required for compliance with national and local codes and standards, which may vary between residential, commercial, and industrial buildings.
- Solenoid valves of any kind, including safety shut-off valves, shall be correctly positioned in the piping to avoid hydraulic shock.
- Solenoid valves of any kind, including safety shut-off valves, shall not block in liquid refrigerant unless adequate relief is provided to the refrigerant system low pressure side.

FAILURE TO ABIDE BY THESE WARNINGS COULD RESULT IN AN EXPLOSION, DEATH, INJURY, AND PROPERTY DAMAGE. READ ALL WARNINGS PRIOR TO INSTALLING, PERFORMING MAINTENANCE, OR SERVICING THE EQUIPMENT IN ANY WAY.

Insight® Single and Multideck

User Safety and Product Information

WARNING

Before Working with R-744 (CO₂) Refrigerant

- **WARNING:** The refrigeration system is under high pressure. Do not tamper with it. Contact qualified service personal before disposal.
- R-744 (CO₂) systems have similar safety concerns with all conventional refrigerants, in that it displaces oxygen, is heavier than air and will concentrate closer to the floor if there is a system leak. R-744 should be monitored for leaks similar to other refrigerants.
- If the refrigeration system is de-energized, venting of the R-744 through the pressure regulating relief valves on the refrigeration system can occur. In such cases, the system might need to be recharged with R-744, but in any case, the pressure regulating relief valve(s) shall not be defeated or capped. The relief setting shall not be altered.
- A sufficient number of pressure relief and pressure regulating relief valves might need to be provided based on the system capacity and located such that no stop valve is provided between the relief valves and the parts or section of the system being protected.
- A pressure relief device shall be installed in the high-pressure side of the refrigeration system between the motor-compressor and the gas cooler. There shall be no shut off devices or other components except piping between the motor-compressor and the pressure relief device that could introduce a pressure drop.
- The pressure relief device shall be mounted so that any refrigerant released from the system during its operation cannot cause harm to the user of the appliance. The aperture shall be located so that it is unlikely to be obstructed in normal use.
- The installed pressure relief device shall have no provisions for setting by the end user.
- The pressure setting of the installed pressure relief device shall be no higher than the design pressure of the high-pressure side.
- Confirm operation of leak detectors (e.g., by exhaling near the sensor), audible / visible alarms, and machine room ventilation before operation.
- Ventilate adjacent enclosed areas to prevent the formation of dangerous concentrations of carbon dioxide.
- Avoid contact of the skin or eyes with solid carbon dioxide (dry ice) or objects cooled by solid carbon dioxide.
- Additional information on the safe use and handling of carbon dioxide can be found in Standards from the Compressed Gas Association Standard (www.cganet.com).
- The following checks shall be applied to installations:
 - a. The actual REFRIGERANT CHARGE is in accordance with the room size within which the refrigerant containing parts are installed.
 - b. The ventilation machinery and outlets are operating adequately and are not obstructed.
 - c. If an indirect refrigerating circuit is being used, the secondary circuit shall be checked for the presence of refrigerant.
 - d. Marking to the equipment continues to be visible and legible. Markings and signs that are illegible shall be corrected.
 - e. Refrigerating pipe or components are installed in a position where they are unlikely to be exposed to any substance which may corrode refrigerant containing components, unless the components are constructed of materials which are inherently resistant to being corroded or are suitably protected against being so corroded.

Insight® Single and Multideck

User Safety and Product Information

WARNING

- Replacement parts must be compatible with the specific equipment’s maximum design pressure as shown on the equipment labeling. For example, if the equipment has been designed to meet 1,305 psig (90 bar) maximum design pressure then any replacement part must be 1,305 psig (90 bar) compatible.
- Never apply heat directly to piping containing CO₂. Rapid thermal expansion of CO₂ can cause the pipe to burst.
- Pressure transducers / leak detectors / warning lights / sounders/buzzers / and plant room ventilation must all be operational prior to charging with CO₂.
- Pressure relief devices / check valves must be located anywhere that liquid CO₂ can be trapped. Trapped CO₂ at -40° F (-40° C) will double in volume if allowed to rise to 86° F (30° C).
- Under no circumstances add Schrader valves to or remove Schrader valves from the system.
- Observe all warnings and labels on the unit being installed or serviced such as the one below indicating high pressure.



- All refrigeration servicing must be completed by a certified refrigeration installation professional, and all tubing and components must be qualified for R-744 (CO₂) applications, with a minimum design pressure that matches the system requirements listed on the equipment (e.g., 1,305 psig [90 bar]).
- Inspect all components prior to installation to ensure that they are free from defects or foreign materials and to confirm that they comply with all pressure and temperature ratings.
- Asphyxiation
 - R-744 is odorless, heavier than air, and is an asphyxiant gas. If sensor reading is maxed out or non-responsive assume an unsafe level of CO₂ and ventilate the room prior to entering.
 - Practical limit of R-744 is 0.006 lb/ft³ (56,000 ppm).
 - Personnel including rescue workers should not enter areas in which the carbon-dioxide content exceeds 3% (30,000 ppm) by measurement unless wearing an SCBA or supplied-air respirator.
 - A leak of R-744 could result in a concentration exceeding the practical limit in an enclosed, occupied space such as a cold room. Precautions must be taken to prevent asphyxiation. These include the use of permanent leak detection, which activates an alarm in the event of a leak.
- The practical limit is defined in ASHRAE 34 but may vary depending on regional regulations. The table below summarizes the effect of R-744 at various concentrations in the air.

PPM of R-744 (CO ₂)	Effects
442	concentration in atmosphere
5,000	long-term exposure limit (8 hours)
15,000	short-term exposure limit (10 minutes)
30,000	discomfort, breathing difficulties, headache, dizziness, etc.
100,000	loss of consciousness, followed by death
300,000	quick and immediate death

Insight® Single and Multideck

User Safety and Product Information



CO₂ Quality

- CO₂ that is purchased for use in refrigeration systems should be of a purity level high enough to prevent accumulation of non-condensable gases and moisture. A build-up of these gases can block small orifices (such as expansion valves) or lead to high discharge pressure, reducing operation or causing the system to become inoperable.
- CO₂ is commercially available at several different purity levels. The common names and percent purity are listed below. Hussmann recommends using “Refrigeration Grade” (99.99% purity) CO₂.
- Mixing of higher purity grades of CO₂ is acceptable. Lower grades of CO₂ contain higher levels of contaminants and water and will decrease system performance. Higher levels of moisture may react with the CO₂ and form carbonic acid that can degrade component integrity. Hussmann recommends keeping enough refrigeration grade CO₂ on-site to charge the system.
- Medical grade CO₂ should not be used, due to the outlet pressure regulators typically present on tanks.
- Bone-Dry grade is the minimum acceptable purity to ensure proper operation of the equipment and is pure enough to technically prevent accumulation of non-condensable gases in the system.
- R-744 (CO₂) purity:

R-744 (CO ₂) Grade	Purity
Industrial and Medical Grade	99.5%
Bone Dry (minimum acceptable)	99.8%
Anaerobic Grade	99.9%
Refrigeration Grade (recommended)	99.99%
Coleman/Instrument Grade	99.99%
Research Grade	99.999%
Ultra-Pure Grade	99.9999%

CO₂ Leak Detector

Leak detectors are required anywhere that CO₂ gas may leak or be vented. Leak detectors provide an alarm if CO₂ is detected at an amount that exceeds the maximum allowable CO₂ concentration. Leak detectors are not provided with the case. Consult local safety codes for exact requirements.

Piping

All piping, whether pre-installed at the factory or added in the field, must be chosen based on the Hussmann engineering transcritical CO₂ specifications, including material type, pipe diameter, and rated maximum working pressure. The design pressure of the system is 1,305 psig (90 bar).

Approved joining methods must be used for all piping and fittings to ensure the pipe’s maximum pressure rating is maintained without reduction. The use roll-stop couplings for straight line pipe joints are recommended. Swaging of pipe joints is not recommended. Swaging weakens the copper at the swage point, reducing the maximum operating pressure rating.

- Piping—minimum design pressure greater than listed design pressure (e.g., 1,305 psig [90 bar])
- Fittings—Mueller Streamline XHP CuFe 1,885 psig (130 bar)
- Braze joints with alloy containing 15% silver (minimum)
 - Flux materials must contain no zinc and must also be water soluble
 - All field piping must be purged with nitrogen while brazing
- Schedule 40 carbon steel pipe or stainless-steel pipe
 - Must protect exterior from corrosion

Insight® Single and Multideck

User Safety and Product Information

Insulation

Insulation should be used in secondary system piping to reduce the heat transfer to ambient air and to maintain subcooling in the CO₂ liquid supply line to the case. The insulation should be sized to allow for the worst-case conditions of heating from store lighting and ambient temperatures. Pipe should be insulated according to local codes and customer specifications and manufacturer specifications.

When installing piping that has not been pre-insulated, there are several options for insulation. Closed-cell elastomeric insulation is extremely popular in refrigeration applications. This type of insulation can also be used in secondary system applications.

The manufacturer's internal case piping valves and components are insulated to prevent frost from building. Sufficient insulation is required on piping into the display case to eliminate frost on tubes and to minimize temperature rise of CO₂.

Check Valves and Pressure Relief Devices

Check valves are required wherever there is a possibility of trapping liquid CO₂ between valves that may be shut-off, including solenoid valves, service valves, and balancing valves. Check valves must be installed to vent high-pressure CO₂ back to the system. Hussmann recommends reverse return tubing instead of the use of shut-off valves for balancing purposes, but if shut-off valves are used, they must be relieved to the system through check valves.



Trapping of liquid CO₂ can result in extremely high pressure and must be avoided to prevent damage to equipment and personal injury.

Solenoid, check, and ball valves with integrated pressure relief must be qualified for CO₂ applications, with a minimum design pressure equal to that listed on the equipment (e.g., 1,305 psig [90 bar]).

The pressure relief device shall be mounted so that any refrigerant released from the system during its operation cannot cause harm to the user of the appliance. The aperture shall be located so that it is unlikely to be obstructed in normal use. The installed pressure relief device shall have no provisions for setting by the end user. The pressure setting of the installed pressure relief device shall be no higher than the design pressure of the high-pressure side.

Startup and Shut Down

If the refrigeration system is de-energized, venting of the R-744 (CO₂) through the pressure regulating relief valves on the refrigeration system can occur. In such cases, the system may need to be recharged with R-744 (CO₂), but in any case, the pressure regulating relief valve(s) are not to be defeated or capped. The relief setting shall not be altered.

Provisions must be made for startup and shutdown to prevent excessive pressures. Consult the pumping station instructions and local codes for requirements.

It is imperative that the case piping is clean and dry prior to charging the system with CO₂. All tubing **MUST** be rated with a minimum design pressure at or above the rating of the equipment. Consult equipment labeling to confirm pressure rating (e.g., 1,305 psig [90 bar]) before installation.

Insight® Single and Multideck User Safety and Product Information

R-744 (CO₂) Pressure-Temperature Chart

A pressure-temperature chart can be found here for reference if needed: https://www.hussmann.com/ns/Supplemental_IO/GD_R-744_CO2_Pressure-Temperature_Chart_M001263_EN.pdf

Example Transcritical CO₂ System Schematic

The system illustrations content in this manual are intended as general references. Diagrams included are for typical units and may differ from the actual unit purchased. Refer to the specific drawings that come with the unit for accurate troubleshooting and maintenance. Additional drawings can be requested if needed.



Insight® Single and Multideck User Safety and Product Information

Example Pumped Liquid CO₂ System Schematic

Example schematic shown, actual design will vary by system.



Pumped Liquid CO₂ System Schematic

Insight® Single and Multideck

User Safety and Product Information

DANGER

Before Working with A2L Refrigerant



- A2L refrigerant is flammable. Equipment that is configured to use A2L refrigerants require special attention. No open flames, cigarettes, or other possible sources of ignition should be used inside or in the vicinity of equipment containing flammable refrigerants.
- Failure to follow instructions can result in an explosion, death, injury and property damage.

WARNING

This refrigeration equipment was manufactured for use with A2L low-flammability refrigerants. Installation and service must only be performed by a qualified service provider.

Failure to abide by this warning could result in an explosion, death, injury, and property damage

- WARNING—Risk of fire or explosion. Flammable refrigerant used. To be repaired only by trained service personnel. Do not puncture refrigerant tubing.
- WARNING—Risk of fire. Dispose of properly in accordance with federal or local regulations. Flammable refrigerant used.
- WARNING—Risk of fire. Flammable refrigerant used. Consult repair manual/owner's guide before attempting to service this product. All safety precautions must be followed.
- WARNING—Risk of fire due to flammable refrigerant used. Follow handling instructions carefully in compliance with national regulations.
- WARNING—Risk of fire or explosion—Store in a well ventilated room without continuously operating flames or other potential ignition.
- WARNING—Risk of fire or explosion—Auxiliary devices which may be ignition sources shall not be installed in the ductwork, other than auxiliary devices listed for use with the specific appliance. See instructions.
- WARNING—In order to reduce flammability hazards the installation of this appliance must only be carried out by a suitably qualified person.
- WARNING—Risk of fire or explosion. Dispose of properly in accordance with federal or local regulations. Flammable refrigerant used.
- A2L refrigerants are denser than air.
- No open flames, cigarettes, or other possible sources of ignition should be used inside the building where the units are located until the qualified service technician and/or local fire department determines that all refrigerant has been cleared from the area and from the refrigeration systems.
- Component parts are designed for use with flammable refrigerants and are non-incendive and non-sparking. To minimize the risk of possible ignition due to incorrect parts, component parts shall only be replaced with identical repair parts. Servicing shall be done by qualified service personnel only, so as to minimize the risk of possible damage due to incorrect parts or improper service.
- Intrinsically safe components are the only types that can be worked on while live in the presence of a flammable atmosphere. The test apparatus shall be at the correct rating.

Insight® Single and Multideck

User Safety and Product Information

WARNING

- Replace components only with parts specified by the manufacturer. Other parts can result in the ignition of refrigerant in the atmosphere from a leak.
- Ducts connected to an appliance shall not contain a potential ignition source.
- Factory installed refrigerant sensors or detectors shall not be disconnected.
- Prior to beginning work on systems containing FLAMMABLE REFRIGERANTS, safety checks are necessary to ensure that the risk of ignition is minimized.
- Work shall be undertaken under a controlled procedure so as to minimize the risk of a flammable gas or vapor being present while the work is being performed.
- All maintenance staff and others working in the local area shall be instructed on the nature of work being carried out. Work in confined spaces shall be avoided.
- The area shall be checked with an appropriate refrigerant detector prior to and during work, to ensure the technician is aware of potentially toxic or flammable atmospheres. Ensure that the leak detection equipment being used is suitable for use with all applicable refrigerants, i.e., non-sparking, adequately sealed, or intrinsically safe.
- If any hot work is to be conducted on the refrigerating equipment or any associated parts, appropriate fire extinguishing equipment shall be available on hand. A dry chemical or CO₂ fire extinguisher should be adjacent to the charging area.
- No person carrying out work in relation to a REFRIGERATING SYSTEM which involves exposing any pipe work shall use any sources of ignition in such a manner that it may lead to the risk of fire or explosion. All possible ignition sources, including cigarette smoking, should be kept sufficiently far away from the site of installation, repairing, removing and disposal, during which refrigerant can possibly be released to the surrounding space. Prior to work taking place, the area around the equipment shall be surveyed to make sure that there are no flammable hazards or ignition risks. “No Smoking” signs shall be displayed.
- Ensure that the area is in the open or that it is adequately ventilated before breaking into the system or conducting any hot work. A degree of ventilation shall continue during the period that the work is carried out. The ventilation should safely disperse any released refrigerant and preferably expel it externally into the atmosphere.
- Where electrical components are being changed, they shall be fit for the purpose and to the correct specification. At all times, the manufacturer’s maintenance and service guidelines shall be followed. If in doubt, consult the manufacturer’s technical department for assistance.

The following checks shall be applied to installations using FLAMMABLE REFRIGERANTS:

- a. The actual REFRIGERANT CHARGE is in accordance with the room size within which the refrigerant containing parts are installed.
- b. The ventilation machinery and outlets are operating adequately and are not obstructed.
- c. If an indirect refrigerating circuit is being used, the secondary circuit shall be checked for the presence of refrigerant.
- d. Marking to the equipment continues to be visible and legible. Markings and signs that are illegible shall be corrected.
- e. Refrigerating pipe or components are installed in a position where they are unlikely to be exposed to any substance which may corrode refrigerant containing components, unless the components are constructed of materials which are inherently resistant to being corroded or are suitably protected against being so corroded.

Insight® Single and Multideck

User Safety and Product Information

A2L Refrigerant Detection System Overview

Refrigerant Detection System

This equipment uses a Danfoss A2L gas sensor for gas concentration monitoring as standard, factory-installed equipment. Check your individual equipment's parts list to confirm which sensor your equipment uses before ordering replacements.

Application

A2L detection devices represent distinctive and intelligent refrigerant or flammable gas detectors. They are designed to identify and precisely measure A2L refrigerants commonly employed in refrigeration applications—detecting potential flammable gas leaks. A2L stationary gas sensors are engineered to continuously monitor and identify leaks of specific flammable refrigerants.

Installer And Operator Responsibility

Sensors require installation and maintenance by a qualified technician who follows all instructions and adheres to the prevailing standards in their respective industry and location. It is crucial to note that these guidelines serve as a reference, and the manufacturer disclaims any responsibility for misuse, improper installation, or operation of these components.

Failure to install and operate the equipment in conformity with provided instructions and all industry and local guidelines may result in severe injuries, including fatality, for which the manufacturer will not be held accountable.

Maintenance

Although the A2L sensor does not require calibration throughout its operational lifespan, routine maintenance is essential to ensure its proper functioning. Routine maintenance involves checking that the sensor membrane is clean and not blocked. Blockage can be removed by lightly brushing with a clean, damp cloth.

Verify its correct operation regularly as part of a maintenance routine. Avoid cleaning the device with corrosive chemicals, solvents, or abrasive detergents. Refrain from spraying cleaning or polishing aerosols onto the device.

View the “A2L Leak Detection Sensor Service and Mitigation” section for information on components, maintenance, and service.

Sensor Life

Leak sensors have an expected fifteen-year lifespan. If any malfunction happens, and it cannot be fixed following the proper troubleshooting procedure before this period, replace it immediately to prevent any fault. This component must be replaced with the same exact part by authorized service personnel only.

It is imperative that the refrigerant sensor, which has been initially installed at the factory, remains integral and should not be intentionally disconnected. Unauthorized disconnection of the factory-installed refrigerant sensor is strictly prohibited, and maintaining its operational status is essential for ensuring the ongoing safety and functionality of the system. Any tampering or disconnection may compromise the ability to detect and alert to the presence of refrigerant, posing potential risks to both equipment and personnel. It is imperative to adhere to these guidelines to uphold the integrity of the refrigeration system and comply with safety standards.

Sensor Location and Position

The location and position of the refrigerant sensor is critical and it should not be moved. It is crucial that the sensors are located only as defined by manufacturer. The position has been determined by laboratory testing to maximize effectiveness in detecting any leak promptly. Positioning sensors as directed by the manufacturer provides accurate performance of the sensor and enhances the overall safety and reliability of the system.

The sensor has an ongoing, self-testing routine to determine if a malfunction has occurred. If the sensor detects a malfunction, the sensor will trigger a mitigation event. Additionally, when the sensor reaches end of life, it will trigger a mitigation event. In both cases, the sensor will need to be replaced to restart the system.

Insight® Single and Multideck

User Safety and Product Information

Splashguard Fans for A2L-Equipped Models

Splashguard fans are required for A2L equipped models e.g., “tall” Insight closed-door cases (4 and 5-deck) and single-deck “short” cases (single, 2-, and 3-deck). The fans are designed to mitigate potential flammability risks and ensure compliance with UL and ASHRAE safety standards.

A2L refrigerants are mildly flammable. A leak inside or outside the case can pose a hazard if refrigerant pools in stagnant areas. If a leak occurs, the shut-off valve system will limit the amount of refrigerant leaked, while the splashguard fan(s) mitigate flammability risk caused by the leaked refrigerant by dispersing leaked vapors away from confined spaces and toward the case’s ventilation path. This ensures concentrations remain below the lower flammability limit (LFL). The splashguard fan is mounted at the bottom of the case, where refrigerant is most likely to accumulate.

As with the leak detection system, the case will not operate if the splashguard fans are not properly installed and in working order as a safety precaution. Do not attempt to operate the case without splashguard fans fully installed.

CAUTION

- Do not use hot/warm water on cold glass surfaces. This can cause the glass to shatter and could result in personal injury. Allow glass fronts to warm before applying hot/warm water.
- Do not allow cleaning agent or cloth to contact food product.
- Product will be degraded and may spoil if allowed to sit in a non-refrigerated area.

NOTICE

- Merchandiser must operate for 24 hours before loading product.
- Regularly check merchandiser temperatures.
- Do not break the cold chain. Keep products in cooler before loading into merchandiser.
- Merchandisers are designed for loading ONLY pre-chilled products.

Model Description

Insight remote case models are designed for the display of medium temperature products. These cases are compatible for use with HFC, HFO (including A2Ls), HCFC, CO₂.

Husmann Product Control

Serial number and shipping date of all equipment is recorded in Husmann’s files for warranty and replacement part purposes. All correspondence pertaining to warranty or parts ordering must include the serial number of each piece of equipment involved. This is to ensure the customer is provided with the correct parts.

Insight® Single and Multideck Installation Information

Equipment Inspection / Shipping Damage

Upon delivery of the equipment, verify that the correct equipment has been received by comparing the information on the equipment serial label with the ordering and submittal documents. All equipment should be thoroughly examined for shipping damage before and during unloading. Equipment has been carefully inspected at our factory prior to shipment. Any claim for loss or damage must be made to the carrier. The carrier will provide any necessary inspection reports and/or claim forms.

Apparent Loss or Damage

If there is an obvious loss or damage, it must be noted on the freight bill or express receipt and signed by the carrier's agent; otherwise, carrier may refuse claim.

Concealed Loss or Damage

When loss or damage is not apparent until after equipment is uncrated, retain all packing materials and submit a written response to the carrier for inspection within 15 days.

Unloading, Moving, and Transporting Case

Move the merchandiser as close as possible to its permanent location and remove all packaging. Check for damage before discarding packaging. Remove all separately packed accessories such as kits and shelves. Improper handling may cause damage to the merchandiser when unloading. Use the shipping brace and arched pod locations to lift when unloading cases.

- Do not drag the merchandiser out of the trailer. Use a Johnson bar (mule).
- Do not lift the case by the liner. Lift with the metal case base, arched plastic pods or the shipping brace.
- Do not lift from the bottom edge of the end panel.

Do not remove shipping braces until the merchandiser is positioned for installation.

Improper handling may cause damage to the merchandiser when unloading. To avoid damage do not drag the merchandiser out of the trailer. Use a Lever Bar (also known as a Mule, Johnson Bar, J-Bar, Lever Dolly, or Pry Lever) where applicable.

A pallet jack is also very helpful in moving a merchandiser to its permanent location. It can also be used to remove optional casters or to shim the case.

Be careful not to damage the factory-installed end while moving the case.



<p>Shipping Brace</p> <p>J-Bar</p> <p>LIFT HERE</p>	<p>LIFT POINTS</p> <p>Shipping Brace & Arched Pod</p> <p>Installer lift at either of THESE POINTS with J-bar when moving case.</p>	<p>Arched Pod Location</p> <p>LIFT HERE</p>
--	---	--

Insight® Single and Multideck Installation Information

Optional Casters and Dollies

Cases may be equipped with factory installed casters or dollies. Instructions for removing the casters or dollies are included in a separate document, shipped with the case. Use caution when transporting cases from the truck to the store location.

⚠ WARNING

If the case is to be moved using a fork lift, position the forks of the lift directly under the arched pods or shipping rails. Use caution when transporting cases. Personal injury or death could result if a case falls on personnel. Use caution when moving cases with casters or dollies. Damage to equipment and personal injury could occur from improper handling.

Location

These merchandisers are designed for displaying products in air-conditioned stores where temperature is maintained at or below the ANSI / NSF-7 specified level and relative humidity is maintained at or below 55%. Refer to the label located on the merchandiser for the recommended maximum ambient operating temperature and relative humidity. Do not exceed the listed ambient conditions.

Placing refrigerated merchandisers in direct sunlight, near hot tables, or near other heat sources could impair their efficiency. Like other merchandisers, these are sensitive to air disturbances. Air currents passing around merchandisers can seriously impair their operation. Do NOT allow air conditioning, electric fans, open doors or windows, etc., to create air currents around the merchandiser.

A 1½-inch (38 mm) space between the rear of the merchandiser and wall must be maintained for air circulation, except for back-to-back merchandisers. However, in high ambient conditions, sweating may still occur. If this happens, install a method of forced ventilation such as a fan ventilation kit.

Note: Under no circumstances should the top or rear of the case be in contact with elements (such as building structures, drywall, etc.) that may restrict airflow or impact operation. Consult listed clearances, or if uncertain, contact a Hussmann representative prior to installation.

Minimum Room Floor Area (A2L only)



The “Minimum Room Floor Area” label provides the minimum room size into which the equipment can be placed. It is the responsibility of the installer to ensure any additional piping and/or equipment is also accounted for separately during installation. Equipment shall not be placed in a room with a floor area less than the value indicated next to the symbol.

Note: Refer to the “Minimum Room Floor Area Table (piping)” to reference the appropriate piping value(s) where needed.

There are two elements related to the room area: Minimum and Actual. Based on the releasable charge determined by internal volume of every component in the equipment, a Minimum Area is calculated. The equipment cannot be used in a space with an area smaller than the Minimum Area. Depending on the Actual Area of the room, different mitigation actions are determined. The Actual Area is based on the inside dimensions of the enclosed space.

Any fluid circuits connected to the appliance (such as to a water heat exchanger) shall safely release abnormal pressure. It shall not allow the release of FLAMMABLE REFRIGERANT into areas served by the other circuits if these do not comply with minimum room area limit.

Insight® Single and Multideck Installation Information

Minimum Room Floor Area Table

Model	Minimum Room Floor Area ft ² (m ²)	Estimated Refrigerant Charge ^A — lb (g)	
		Operating Charge	
		R-454A	R-454C
IC1BL4	106 (9.8)	0.7 (331)	0.7 (331)
IC1BL6	106 (9.8)	1 (473)	1.1 (478)
IC1BL8	106 (9.8)	1.4 (621)	1.4 (621)
IC1BL12	196 (18.2)	2.1 (957)	2.1 (957)
IC2NL4, IC2SL4, IC2SM4	106 (9.8)	1.3 (610)	1.3 (610)
IC2NL6, IC2SL6, IC2SM6	106 (9.8)	1.8 (833)	1.9 (842)
IC2NL8, IC2SL8, IC2SM8	106 (9.8)	2.4 (1,089)	2.4 (1,089)
IC2NL12, IC2SL12, IC2SM12	196 (18.2)	3.5 (1,595)	3.6 (1,612)
IC2XNL4, IC2XSL4, IC2XSM4	106 (9.8)	1.4 (620)	1.4 (620)
IC2XNL6, IC2XSL6, IC2XSM6	106 (9.8)	1.9 (852)	1.9 (852)
IC2XNL8, IC2XSL8, IC2XSM8	196 (18.2)	2.4 (1,099)	2.4 (1,099)
IC2XNL12, IC2XSL12, IC2XSM12	196 (18.2)	3.6 (1,622)	3.6 (1,622)
IC3BL4, IC3BM4	106 (9.8)	1.4 (624)	1.4 (624)
IC3BL6, IC3BM6	106 (9.8)	2 (847)	1.9 (856)
IC3BL8, IC3BM8	196 (18.2)	2.5 (1,092)	2.4 (1,104)
IC3BL12, IC3BM12	196 (18.2)	3.6 (1,626)	3.6 (1,626)
IC3SL4	106 (9.8)	1.4 (635)	1.4 (635)
IC3SL6	106 (9.8)	1.9 (867)	1.9 (867)
IC3SL8	196 (18.2)	2.4 (1,103)	2.5 (1,114)
IC3SL12	196 (18.2)	3.6 (1,637)	3.6 (1,637)
IC4BM4, IC4SL4	106 (9.8)	1.4 (658)	1.5 (665)
IC4BM6, IC4SL6	106 (9.8)	2 (897)	2 (897)
IC4BM8, IC4SL8	196 (18.2)	2.5 (1,145)	2.5 (1,145)
IC4BM12, IC4SL12	196 (18.2)	3.6 (1,650)	3.7 (1,668)
IC4SLO90X	106 (9.8)	1.9 (859)	1.9 (859)
IC5BL4, IC5BL4TE	106 (9.8)	1.4 (653)	1.5 (660)
IC5BL6, IC5BL6TE	106 (9.8)	1.9 (884)	2 (893)
IC5BL8, IC5BL8TE	196 (18.2)	2.5 (1,142)	2.5 (1,142)
IC5BL12, IC5BL12TE	196 (18.2)	3.7 (1,679)	3.7 (1,679)
IC6SL4, IC6SM4	106 (9.8)	1.6 (728)	1.6 (728)
IC6SL6, IC6SM6	196 (18.2)	2.2 (990)	2.2 (990)
IC6SL8, IC6SM8	196 (18.2)	2.8 (1,269)	2.8 (1,269)
IC6SL12, IC6SM12	196 (18.2)	4.1 (1,866)	4.1 (1,866)
IC6SL4R	106 (9.8)	1.6 (726)	1.6 (726)
IC6SL6R	196 (18.2)	2.1 (970)	2.1 (970)
IC6SL8R	196 (18.2)	2.8 (1,251)	2.8 (1,264)
IC6SL12R	196 (18.2)	4.1 (1,855)	4.1 (1,855)

^A Approximate charge based on normal operating conditions

Insight® Single and Multideck Installation Information

Model	Minimum Room Floor Area ft ² (m ²)	Estimated Refrigerant Charge ^A — lb (g)	
		Operating Charge	
		R-454A	R-454C
ID5NL4, ID5NM4, ID5NV4, ID5SL4, ID5SM4, ID5SL4TE	106 (9.8)	1.4 (657)	1.4 (657)
ID5NL6, ID5NM6, ID5NV6, ID5SL6, ID5SM6, ID5SL6TE	106 (9.8)	1.9 (877)	2 (887)
ID5NL8, ID5NM8, ID5NV8, ID5SL8, ID5SM8, ID5SL8TE	196 (18.2)	2.5 (1,137)	2.5 (1,137)
ID5NL12, ID5NM12, ID5NV12, ID5SL12, ID5SM12, ID5SL12TE	196 (18.2)	3.6 (1,643)	3.7 (1,660)
ID5SL4R, ID5SM4R, ID5SL4RS	106 (9.8)	1.4 (651)	1.4 (651)
ID5SL6R, ID5SM6R, ID5SL6RS	106 (9.8)	1.9 (878)	1.9 (878)
ID5SL8R, ID5SM8R, ID5SL8RS	196 (18.2)	2.5 (1,125)	2.5 (1,125)
ID5SL12R, ID5SM12R, ID5SL12RS	196 (18.2)	3.6 (1,644)	3.6 (1,644)
ID5SLI45	106 (9.8)	0.9 (430)	0.9 (430)
ID5SLI90X	106 (9.8)	1.5 (693)	1.5 (693)
ID5SLO45	106 (9.8)	1.2 (534)	1.2 (534)
ID5SLO90X	106 (9.8)	1.9 (861)	1.9 (861)
ID5SLO90Z	106 (9.8)	1.5 (693)	1.5 (693)
ID5SMI45	106 (9.8)	0.9 (430)	0.9 (430)
ID5SMO45	106 (9.8)	1.2 (534)	1.2 (534)
ID5SMO90X	106 (9.8)	1.9 (870)	1.9 (870)
ID5SU4, ID5SV4	106 (9.8)	1.5 (665)	1.5 (665)
ID5SU6, ID5SV6	106 (9.8)	2 (901)	2 (901)
ID5SU8, ID5SV8	196 (18.2)	2.5 (1,142)	2.5 (1,142)
ID5SU12, ID5SV12	196 (18.2)	3.7 (1,684)	3.7 (1,684)
ID6NL4, ID6NU4, ID6SU4, ID6SV4	106 (9.8)	1.6 (728)	1.6 (728)
ID6NL6, ID6NU6, ID6SU6, ID6SV6	106 (9.8)	2.2 (990)	2.2 (990)
ID6NL8, ID6NU8, ID6SU8, ID6SV8	196 (18.2)	2.8 (1,269)	2.8 (1,269)
ID6NL12, ID6NU12, ID6SU12, ID6SV12	196 (18.2)	4.1 (1,866)	4.1 (1,866)
ID6SU4R	106 (9.8)	1.6 (725)	1.6 (725)
ID6SU6R	106 (9.8)	2.1 (970)	2.1 (970)
ID6SU8R	196 (18.2)	2.8 (1,263)	2.8 (1,263)
ID6SU12R	196 (18.2)	4 (1,837)	4.1 (1,854)
IDD5NL4, IDD5SL4, IDD5SL4TE	106 (9.8)	1.1 (517)	1.1 (517)
IDD5NL6, IDD5SL6, IDD5SL6TE	106 (9.8)	1.6 (727)	1.6 (727)
IDD5NL8, IDD5SL8, IDD5SL8TE	196 (18.2)	2.1 (950)	2.1 (950)
IDD5NL12, IDD5SL12, IDD5SL12TE	196 (18.2)	3 (1,386)	3 (1,386)
IDD5SL4R	106 (9.8)	1.1 (499)	1.1 (499)
IDD5SL6R	106 (9.8)	1.6 (718)	1.6 (718)
IDD5SL8R	196 (18.2)	2.0 (927)	2.1 (935)
IDD5SL12R	196 (18.2)	3.0 (1,367)	3.0 (1,367)
IDD5SU4, IDD5SV4	106 (9.8)	1.1 (519)	1.1 (519)
IDD5SU6, IDD5SV6	106 (9.8)	1.6 (730)	1.6 (730)
IDD5SU8, IDD5SV8	196 (18.2)	2.1 (956)	2.1 (956)
IDD5SU12, IDD5SV12	196 (18.2)	3 (1,380)	3.1 (1,392)

^A Approximate charge based on normal operating conditions

Insight® Single and Multideck Installation Information

Model	Minimum Room Floor Area ft ² (m ²)	Estimated Refrigerant Charge ^A — lb (g)	
		Operating Charge	
		R-454A	R-454C
IDD6NL4	106 (9.8)	1.1 (521)	1.1 (521)
IDD6NL6	106 (9.8)	1.6 (730)	1.6 (730)
IDD6NL8	196 (18.2)	2.1 (952)	2.1 (952)
IDD6NL12	196 (18.2)	3 (1,377)	3.1 (1,388)
IDD6NU4, IDD6SU4, IDD6SV4	106 (9.8)	1.1 (518)	1.2 (523)
IDD6NU6, IDD6SU6, IDD6SV6	106 (9.8)	1.6 (732)	1.6 (732)
IDD6NU8, IDD6SU8, IDD6SV8	196 (18.2)	2.1 (959)	2.1 (959)
IDD6NU12, IDD6SU12, IDD6SV12	196 (18.2)	3.1 (1,395)	3.1 (1,395)
IDD6SU4R	106 (9.8)	N/A	1.3 (580)
IDD6SU6R	106 (9.8)	N/A	1.8 (811)
IDD6SU8R	196 (18.2)	N/A	2.4 (1,069)
IDD6SU12R	196 (18.2)	N/A	3.4 (1,563)
IM1SL4, IM1SM4	106 (9.8)	0.7 (331)	0.7 (331)
IM1SL6, IM1SM6	106 (9.8)	1 (474)	1.1 (479)
IM1SL8, IM1SM8	106 (9.8)	1.4 (622)	1.4 (622)
IM1SL12, IM1SM12	196 (18.2)	2.1 (958)	2.1 (958)
IM1SL4L	106 (9.8)	0.7 (336)	0.7 (336)
IM1SL6L	106 (9.8)	1.1 (485)	1.1 (485)
IM1SL8L	106 (9.8)	1.4 (629)	1.4 (629)
IM1SL12L	196 (18.2)	2.1 (959)	2.1 (959)
IM3SL4, IM4SL4	106 (9.8)	1.5 (665)	1.5 (665)
IM3SL6, IM4SL6	106 (9.8)	2.0 (897)	2.0 (897)
IM3SL8, IM4SL8	196 (18.2)	2.5 (1,142)	2.5 (1,142)
IM3SL12, IM4SL12	196 (18.2)	3.6 (1,668)	3.6 (1,668)
IM4SLI90X	106 (9.8)	1.0 (480)	1.0 (480)
IM5NL4, IM5SL4	106 (9.8)	1.5 (666)	1.5 (666)
IM5NL6, IM5SL6	106 (9.8)	2 (887)	2 (887)
IM5NL8, IM5SL8	196 (18.2)	2.5 (1,145)	2.5 (1,145)
IM5NL12, IM5SL12	196 (18.2)	3.6 (1,651)	3.7 (1,668)
IP1SL4, IP1XSL4, IP1XXSL4	106 (9.8)	0.7 (332)	0.7 (332)
IP1SL6, IP1XSL6, IP1XXSL6	106 (9.8)	1 (474)	1.1 (479)
IP1SL8, IP1XSL8, IP1XXSL8	106 (9.8)	1.4 (622)	1.4 (622)
IP1SL12, IP1XSL12, IP1XXSL12	196 (18.2)	2.1 (959)	2.1 (959)
IP2SL4, IP4NL4, IP4SL4	106 (9.8)	1.5 (666)	1.5 (666)
IP2SL6, IP4NL6, IP4SL6	106 (9.8)	2 (887)	2 (887)
IP2SL8, IP4NL8, IP4SL8	196 (18.2)	2.5 (1,145)	2.5 (1,145)
IP2SL12, IP4NL12, IP4SL12	196 (18.2)	3.6 (1,651)	3.7 (1,668)
IP4SLI45	106 (9.8)	0.9 (430)	0.9 (430)
IP4SLI90X	106 (9.8)	1.5 (691)	1.5 (691)

^A Approximate charge based on normal operating conditions.

Insight® Single and Multideck Installation Information

Minimum Room Floor Area Table (piping)

Liquid Line Piping Minimum Area in ft ² (m ²)										
Line Length ft (m)	Line Size (OD)									
	3/8"	1/2"	5/8"	7/8"	1 1/8"	1 3/8"	1 5/8"	1 7/8"	2 1/8"	2 5/8"
5 (1.5)	25 (2.3)	30 (2.8)	40 (3.7)	60 (5.6)	85 (7.9)	125 (11.6)	165 (15.3)	220 (20.4)	275 (25.5)	410 (38.1)
10 (3)	30 (2.8)	45 (4.2)	60 (5.6)	100 (9.3)	155 (14.4)	225 (20.9)	315 (29.2)	420 (39)	530 (49.2)	805 (74.8)
15 (4.6)	40 (3.7)	55 (5.1)	80 (7.4)	140 (13)	225 (20.9)	330 (30.7)	460 (42.7)	620 (57.6)	785 (72.9)	1,200 (111.5)
20 (6.1)	45 (4.2)	70 (6.5)	100 (9.3)	180 (16.7)	290 (26.9)	435 (40.4)	605 (56.2)	825 (76.6)	1,040 (96.6)	1,590 (147.7)
25 (7.6)	50 (4.6)	80 (7.4)	120 (11.1)	220 (20.4)	360 (33.4)	540 (50.2)	755 (70.1)	1,025 (95.2)	1,300 (120.8)	1,985 (184.4)
30 (9.1)	60 (5.6)	95 (8.8)	140 (13)	260 (24.2)	430 (39.9)	645 (59.9)	900 (83.6)	1,225 (113.8)	1,555 (144.5)	2,380 (221.1)
40 (12.2)	70 (6.5)	120 (11.1)	180 (16.7)	340 (31.6)	565 (52.5)	850 (79)	1,195 (111)	1,625 (151)	2,065 (191.8)	3,165 (294)
50 (15.2)	85 (7.9)	145 (13.5)	220 (20.4)	420 (39)	705 (65.5)	1,060 (98.5)	1,490 (138.4)	2,030 (188.6)	2,575 (239.2)	3,950 (367)
75 (22.9)	115 (10.7)	210 (19.5)	325 (30.2)	625 (58.1)	1,045 (97.1)	1,580 (146.8)	2,225 (206.7)	3,035 (282)	3,855 (358.1)	5,915 (549.5)
100 (30.5)	150 (13.9)	270 (25.1)	425 (39.5)	825 (76.6)	1,385 (128.7)	2,100 (195.1)	2,960 (275)	4,040 (375.3)	5,135 (477.1)	7,885 (732.5)
Vapor Line Piping Minimum Area in ft ² (m ²)										
Line Length ft (m)	Line Size (OD)									
	3/8"	1/2"	5/8"	7/8"	1 1/8"	1 3/8"	1 5/8"	1 7/8"	2 1/8"	2 5/8"
5 (1.5)	20 (1.9)	20 (1.9)	20 (1.9)	20 (1.9)	20 (1.9)	20 (1.9)	20 (1.9)	25 (2.3)	25 (2.3)	30 (2.8)
10 (3)	20 (1.9)	20 (1.9)	20 (1.9)	20 (1.9)	20 (1.9)	25 (2.3)	25 (2.3)	30 (2.8)	30 (2.8)	40 (3.7)
15 (4.6)	20 (1.9)	20 (1.9)	20 (1.9)	20 (1.9)	25 (2.3)	25 (2.3)	30 (2.8)	35 (3.3)	40 (3.7)	50 (4.6)
20 (6.1)	20 (1.9)	20 (1.9)	20 (1.9)	25 (2.3)	25 (2.3)	30 (2.8)	35 (3.3)	40 (3.7)	45 (4.2)	60 (5.6)
25 (7.6)	20 (1.9)	20 (1.9)	20 (1.9)	25 (2.3)	30 (2.8)	30 (2.8)	40 (3.7)	45 (4.2)	50 (4.6)	70 (6.5)
30 (9.1)	20 (1.9)	20 (1.9)	20 (1.9)	25 (2.3)	30 (2.8)	35 (3.3)	40 (3.7)	50 (4.6)	60 (5.6)	80 (7.4)
40 (12.2)	20 (1.9)	20 (1.9)	25 (2.3)	25 (2.3)	35 (3.3)	40 (3.7)	50 (4.6)	60 (5.6)	70 (6.5)	100 (9.3)
50 (15.2)	20 (1.9)	20 (1.9)	25 (2.3)	30 (2.8)	35 (3.3)	45 (4.2)	55 (5.1)	70 (6.5)	85 (7.9)	120 (11.1)
75 (22.9)	20 (1.9)	25 (2.3)	25 (2.3)	35 (3.3)	45 (4.2)	60 (5.6)	75 (7)	95 (8.8)	120 (11.1)	170 (16)
100 (30.5)	20 (1.9)	25 (2.3)	30 (2.8)	40 (3.7)	55 (5.1)	75 (7)	95 (8.8)	125 (11.6)	150 (13.9)	225 (20.9)

Insight® Single and Multideck Installation Information

End Shipping Braces

Move the merchandiser as close as possible to its permanent location, then remove all packaging. Check for damage before discarding packaging. Remove all separately packed accessories such as kits and shelves. Do not remove end braces until case joining begins. Recycle wooden braces and hardware.

1. Remove screws (6) and wooden supports prior to moving case into Position (rear rail will remain attached to merchandiser).



Shipping Rider

Some merchandisers are shipped on a rider to protect the factory installed front legs, and to make positioning the merchandiser easier. To remove the rider, remove bolts attaching rider to each leg.



CAUTION

Tipping Hazard! Case tipping may occur if cases are not properly leveled and secured, or if cases are not properly loaded.

Cases with Installed Ends

If the case was shipped with the end installed, two long bolts were used to hold the shipping brace to the end. If the shipping bolts are reinserted after removing the brace, they will extend into the product area and may damage the coil. Therefore, be sure to replace these bolts with the shorter bolts provided. Be careful not to damage the factory-installed end while moving the merchandiser.

Leveling Case

Merchandisers must be installed level to ensure proper operation of the refrigeration system and to ensure proper drainage of defrost water. Pay close attention to case position during all steps of setting, joining and leveling. For cases installed in a lineup, leveling starts from the highest point of the store floor.

Preparation:

1. Using store blueprints, measure off and mark on floor the exact dimensions/locations of the merchandiser footprint. A 1 ½ (38 mm) inch space is required behind each merchandiser to prevent condensation.
2. Snap a chalk line for the front and rear positions of the base pods.
3. Mark the location of each joint from front to back lines.
4. Use supplied shims to level case. Shims are to be inserted under the black, plastic base pods. Placing shims at other locations will cause uneven distribution of weight leading to piping leaks, as well as sagging or wracked doors.



Insight® Single and Multideck Installation Information

For Case Lineups

1. The whole lineup must be leveled on the same plane, left to right and front to back. This means that the entire lineup must be brought up to the level of the highest case in the lineup.
2. Along the lines previously marked, find the highest point of the floor by:
 - Walking the floor and noticing any dips or mounds
 - Using a string level, and using a transit
3. Position the first merchandiser at the highest point on the floor. Work outward from that point to create the merchandiser lineup.
4. Use a 48 inch (1220 mm) or longer level for end-to-end leveling. The rear edge of the top foam panel of the merchandiser is a good location for the level at the rear of the case.
5. For leveling the merchandiser front-to-rear, a 24 inch (610 mm) level should be placed on the lower flange of the merchandiser end frame. If the merchandiser has a factory installed end, the level should be placed on the canopy support brackets on top of the merchandiser.



Case Joining

Joining kits are shipped with each merchandiser as ordered. To join like fixtures, a joining kit is required. Sectional construction means that two or more merchandisers may be joined in line yielding one long, continuous display requiring only one pair of ends.

- To join same temperature merchandisers on different defrost cycles, a partition kit is required.
- All joints must be air-tight to prevent formation of ice or condensation.

Joining and Sealing Hardware (dimensions in inches)	Multideck Qty/Each	Convertible Qty/Each	Single Deck Qty/Each	Door Multideck Qty/Each
sealer silicone adhesive	1	1	1	1
gasket 1/2 x 1/2 x 180	2	1	1	2
screw-sheet metal #8 x 5/8 phil hx hd	n/a	1	n/a	n/a
screw-cap 1/4 x 3/4 hex	n/a	n/a	n/a	2
bolt hex cap 5/16 x 3/4	1	1	1	1
bolt 5/16 x 2 3/4 grade 5 zinc plated tap	2	n/a	n/a	2
bolt- tap, 5/16 x 4 1/2, steel, (qty varies)	5	2	1	5
bolt- tap, 5/16 x 7, steel, zinc finish, gr5	1	1	1	1
washer-flat 5/16 zinc (qty varies)	13	5	3	13
lockwasher 1/4 spl t stl	n/a	n/a	n/a	2
lockwasher 5/16 spl t stl	1	1	1	1
nut-hex 1/4	n/a	n/a	n/a	2
nut-hex 5/16 steel (qty varies)	9	4	3	9
nut-hex 3/8-24 serrated flange	4	n/a	n/a	4
pin-alignment	1	1	1	n/a
cone-case alignment (qty varies)	4	2	2	4
plate-bott door rail alignment	n/a	n/a	n/a	1
bracket-case joining	4	n/a	n/a	4
bracket-fascia alignment (IC2 & IC3 cases)	n/a	1	n/a	n/a
cover-hand rail joint	1	1	1	n/a
tape-butyl 1/16 x 2 x 49	1	1	1	1

Insight® Single and Multideck

Installation Information

screw-sheet metal #8 x 5/8		
screw-cap 1/4 x 3/4		
bolt-5/16 x 3/4		
bolt-5/16 x 2 3/4		
bolt-5/16 x 4 1/2		
bolt-5/16 x 7		
washer flat-5/16		
washer lock-1/4		
washer lock-5/16		
nut hex-1/4		
nut hex-5/16		
nut hex-3/8 serrated flange		
pin-alignment		
cone-alignment		
plate-bottom door rail alignment		
bracket-case joining		
bracket-fascia alignment IC2 & IC3		
cover-handrail joint		

Insight® Single and Multideck Installation Information

Apply Gaskets - Multideck IP4 / IM5 / ID5 / ID6 / IC6 / IC4

Case bolting details begin on the next page.

LEGEND:

A = 1/2 x 1/2 inch gasket

B = neutral curing silicone sealant

C = pin-alignment

D = cover-hand rail joint

IMPORTANT:

- Do not pull cases together with bolts. Cases must be moved together as close as possible. Follow sequence balloons to tighten bolts.
- Apply gasket to only one side of case joint
- Remove end shipping braces
- Cases must be leveled
- Remove any casters (if installed)
- Install case lineup from left to right
- Remove shelves, display racks, pans & interior back panels at the joining area
- Insert gasket into case channels the entire length with no gaps
- Do not stretch gasket, especially around corners
- Do not butt gaskets, always overlap them
- Remove paper backing after gasket has been applied
- Perimeter gasket is required by NSF
- Apply a continuous bead of neutral curing silicone sealant
- Joints must be air tight to prevent formation of ice or condensation

It is the installing contractor's responsibility to consult local agencies for local code requirements.



Insight® Single and Multideck Installation Information

Case Joining - Multideck & Rear-load IP4 / IM5 / ID5 / ID6 / IC6 / IC4

LEGEND:

C = pin-alignment

Do not pull cases together with bolts. Cases must be moved together as close as possible. Follow sequence balloons to tighten bolts.



Insight® Single and Multideck Installation Information

Case Joining - Multideck & Rear-load
IP4 / IM5 / ID5 / ID6 / IC6 / IC4

Refer to detail views.

This bolt location is optional for some installed kits.



SLIDE BRACKET
TO COMPLETE
JOINT

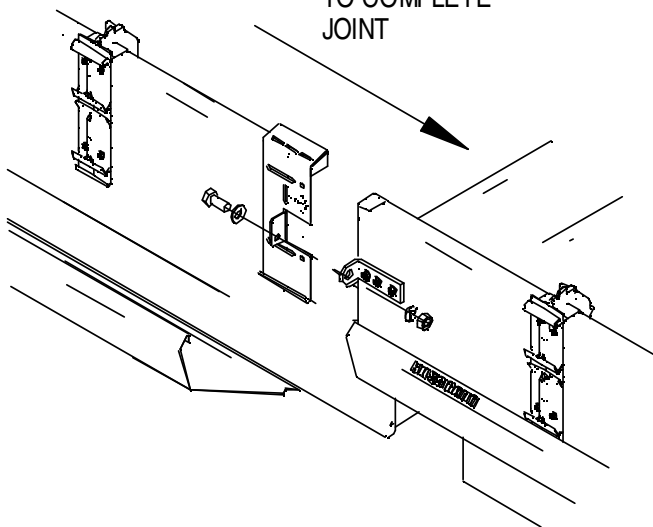

5/16 X 3/4 BOLT (5)

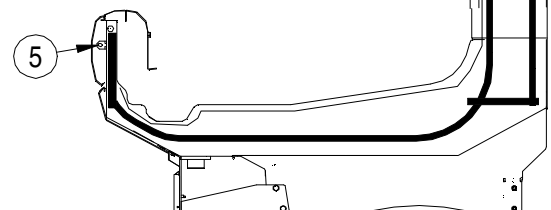

Insight® Single and Multideck Installation Information

Case Joining Multideck & Rear-load IP4 / IM5 / ID5 / ID6 / IC6 / IC4

Refer to detail views.

LEGEND:

D = cover-hand rail joint

Push Cover in this
direction to snap fit

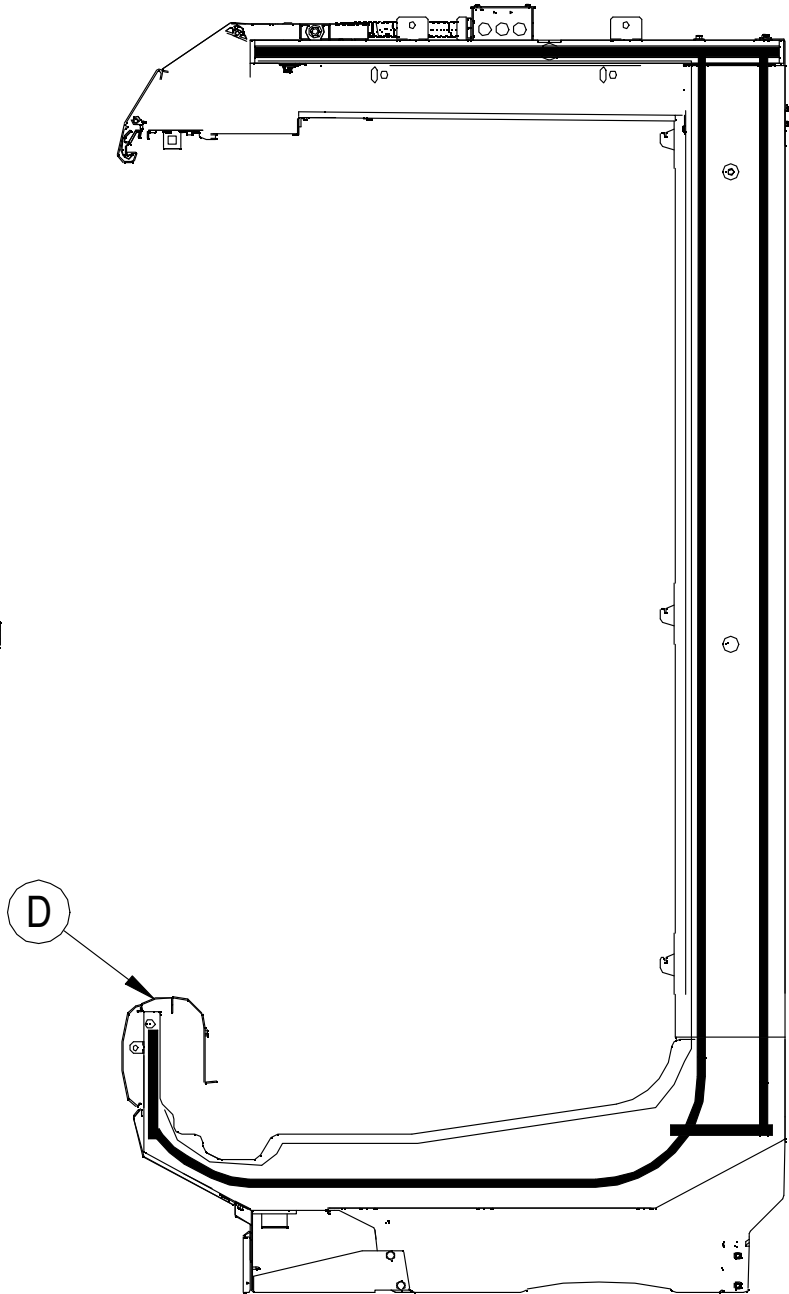
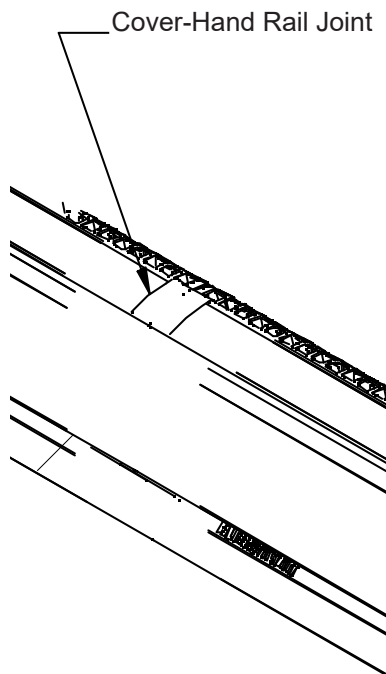

Insight® Single and Multideck Installation Information

Apply Gaskets - Convertible IC2 / IC2X / IC3

Case bolting details begin on the next page.

LEGEND:

A = 1/2 x 1/2 inch gasket

B = neutral curing silicone sealant

C = pin-alignment

D = cover-hand rail joint

E = bracket-fascia alignment



IMPORTANT:

- Do not pull cases together with bolts.
Cases must be moved together as close as possible.
Follow sequence balloons to tighten bolts.
- Apply gasket to only one side of case joint
- Remove end shipping braces
- Cases must be leveled
- Remove any casters (if installed)
- Install case lineup from left to right
- Remove shelves, display racks, pans & interior back panels at the joining area
- Insert gasket into case channels the entire length with no gaps
- Do not stretch gasket, especially around corners
- Do not butt gaskets, always overlap them
- Remove paper backing after gasket has been applied
- Perimeter gasket is required by NSF
- Apply a continuous bead of neutral curing silicone sealant
- Joints must be air tight to prevent formation of ice or condensation

It is the installing contractor's responsibility to consult local agencies for local code requirements.

Insight® Single and Multideck Installation Information

**Case Joining - Convertible
IC2 / IC2X / IC3**
Refer to detail views.

LEGEND:

C = pin-alignment

E = bracket-fascia alignment

Do not pull cases together with bolts. Cases must be moved together as close as possible. Follow sequence balloons to tighten bolts.



Insight® Single and Multideck Installation Information

Case Joining - Convertible
IC2 / IC2X / IC3
 Refer to detail views.

LEGEND:

E = bracket-fascia alignment

(Can be modified by hand for better fit if necessary)

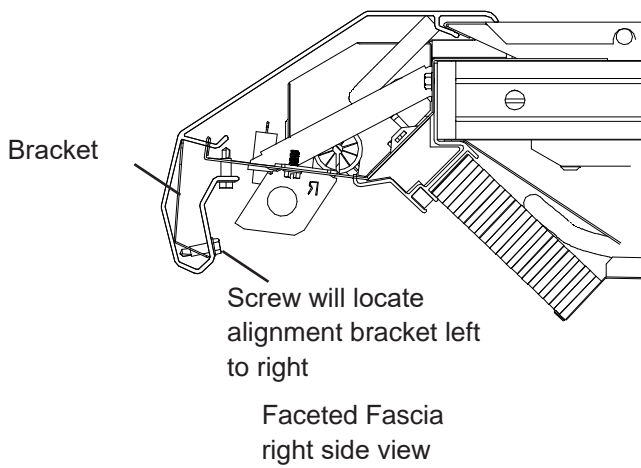

Existing Fascia Brackets
will locate Alignment
Bracket left to right



Insight® Single and Multideck Installation Information

Case Joining - Convertible
IC2 / IC2X / IC3
Refer to detail views.



Insight® Single and Multideck Installation Information

Case Joining (Convertible)
IC2 / IC2X / IC3
Refer to detail views.

LEGEND:

D = cover-hand rail joint



Push Cover
in this direction
to snap fit



Insight® Single and Multideck Installation Information

Apply Gasket- Single Deck

IM1 / IP1 Case bolting details begin on the next page.

LEGEND:

A = 1/2 x 1/2 inch gasket

B = neutral curing silicone sealant

C = pin-alignment

D = cover-hand rail joint

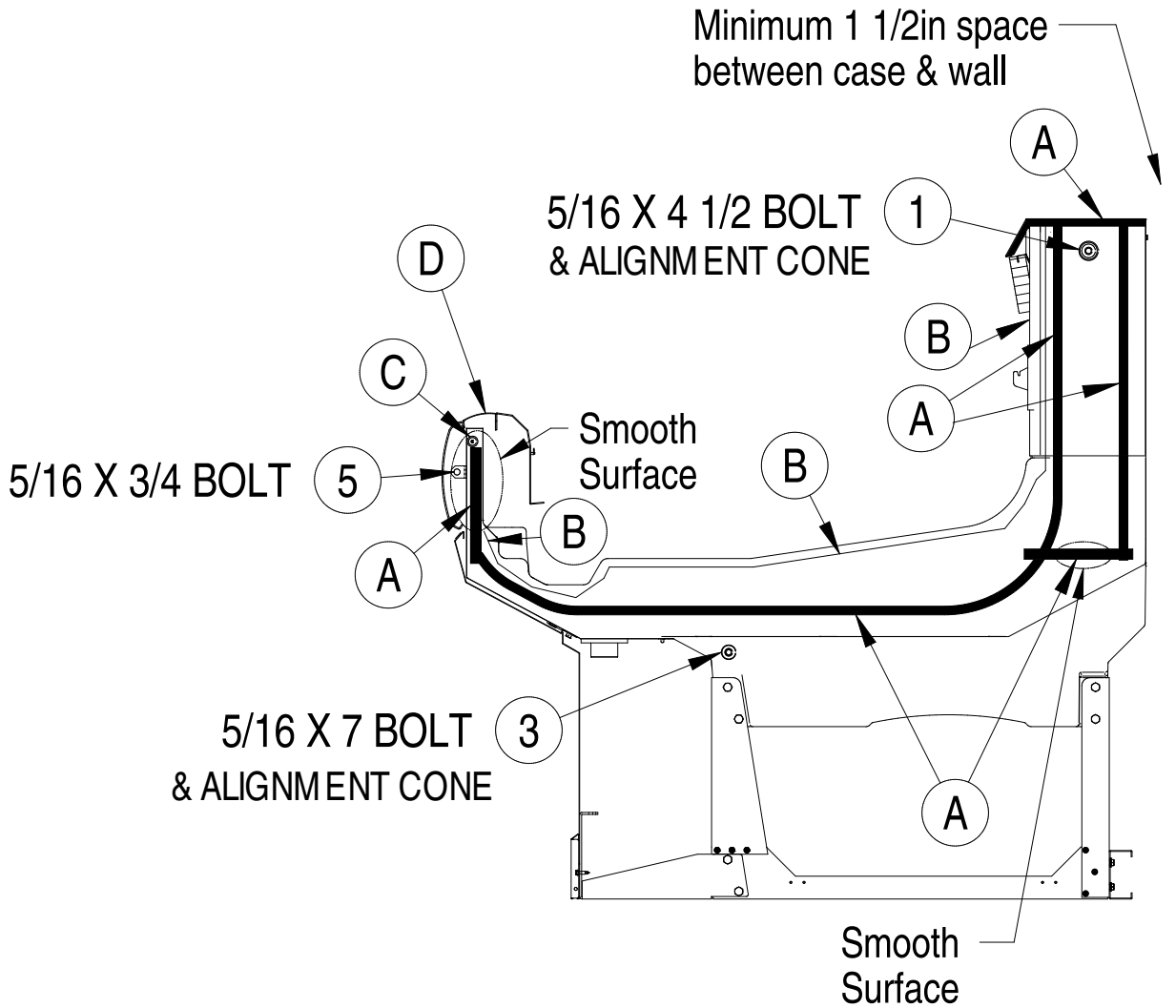

Insight® Single and Multideck Installation Information

Case Joining - Single Deck

IM1 / IP1

Refer to detail views.

LEGEND:

C = pin-alignment

Do not pull cases together with bolts. Cases must be moved together as close as possible. Follow sequence balloons to tighten bolts.

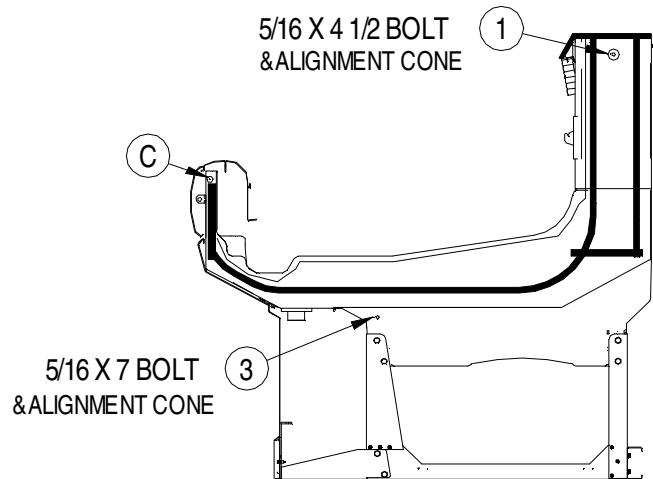

IMPORTANT:

- Do not pull cases together with bolts. Cases must be moved together as close as possible. Follow sequence balloons to tighten bolts.
- Apply gasket to only one side of case joint
- Remove end shipping braces
- Cases must be leveled
- Remove any casters (if installed)
- Install case lineup from left to right
- Remove shelves, display racks, pans & interior back panels at the joining area
- Insert gasket into case channels the entire length with no gaps
- Do not stretch gasket, especially around corners
- Do not butt gaskets, always overlap them
- Remove paper backing after gasket has been applied
- Perimeter gasket is required by NSF
- Apply a continuous bead of neutral curing silicone sealant
- Joints must be air tight to prevent formation of ice of condensation

It is the installing contractor's responsibility to consult local agencies for local code requirements.

Insight® Single and Multideck Installation Information

Case Joining - Single Deck
IM1 / IP1 Refer to detail views.



Insight® Single and Multideck Installation Information

Case Joining - Single Deck
IM1 / IP1 Refer to detail views.

LEGEND:

D = cover-hand rail joint



Push Cover
in this direction
to snap fit

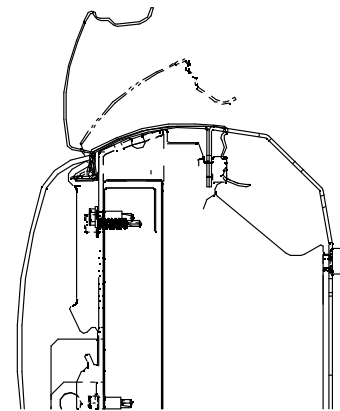
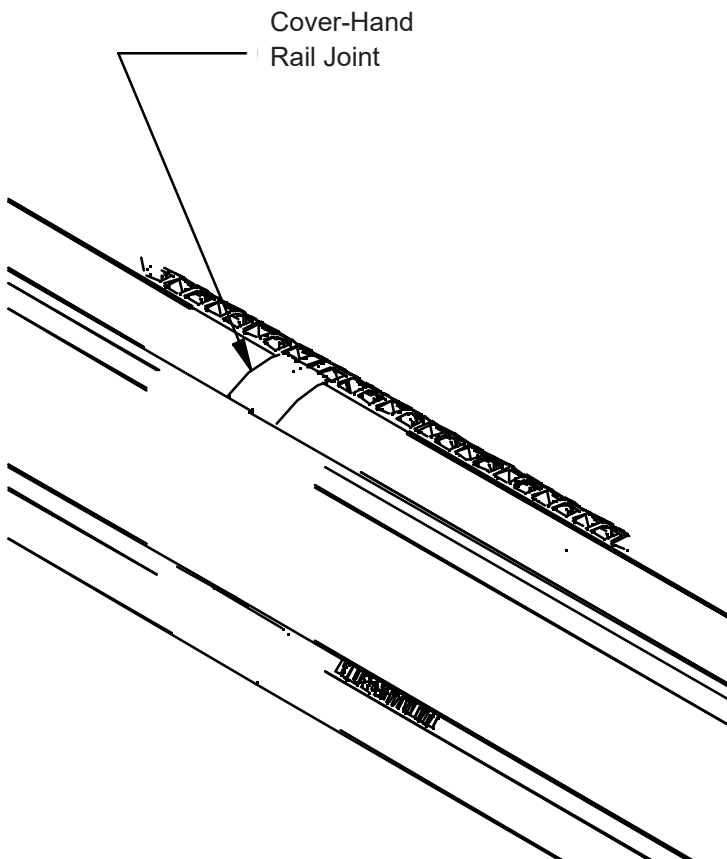

Insight® Single and Multideck Installation Information

Sealing Lineup Joints (all cases)

The joint between the two joined case must be sealed for sanitation. Apply Butyl tape across the case joint. Apply a long, continuous bead of silicone to fill any gaps between the cases.

Be sure to start from the back and go all the way to the air return as shown in the illustration below.



IMPORTANT

Fill any gaps between cases with silicone.



Apply Butyl Tape



Apply Neutral Curing Silicone Sealant

Apply Neutral Curing Silicone Sealant in any gaps between the Case Joints.

Insight® Single and Multideck Installation Information

Sealing Rear-load Cases

Sealing case(s) in front of cooler opening:

Rear-load cases are designed to be installed in the cooler opening. A 1½ in. gap around the outside of the cooler opening must be maintained. Use the dimensions below to build a sealed wall between the cooler opening and the rear of the case(s). Use silicone around the perimeter of the frame to seal the cases on the inside and outside of the cooler.

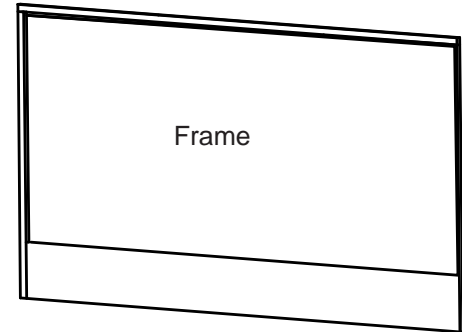

A frame must be built between the cooler opening and the rear-loading area of the case(s). Seal the frame with silicone. The area around the rear access doors should be sealed to the cooler wall. The seal should be air and water tight.

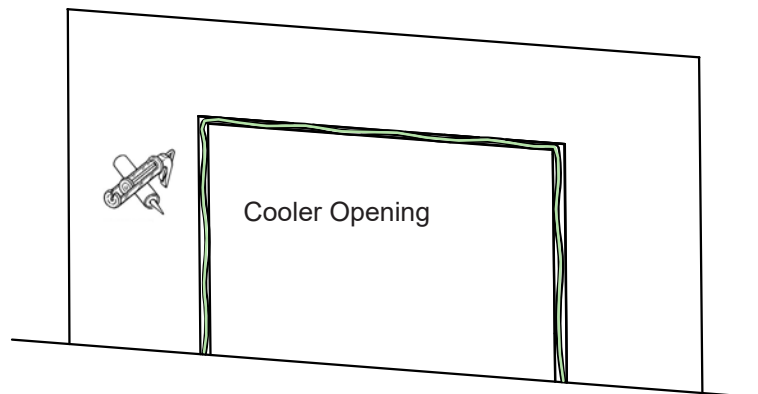

Insight® Single and Multideck Installation Information

Rear view dimensions ID6SUR / ID5SLR of cases with external sliding rear-loading doors (4 ft, 6 ft, 8 ft, 12 ft)



Item	ID6SUR Merchandisers			
	4ft	6ft	8ft	12ft
A	6 ¹ / ₈ (155)			
B	67 ¹ / ₂ (1724)			
C	16 ¹ / ₈ (419)			
D	5 ¹ / ₈			
* E	12 ¹ / ₄ (309)	8 ¹ / ₈ (206)	12 ¹ / ₄ (309)	12 ¹ / ₄ (309)
* F	24 ⁷ / ₈ (631)	17 (430)	24 ⁷ / ₈ (631)	24 ⁷ / ₈ (631)
G	37 ¹ / ₈ (941)	25 ¹ / ₈ (636)	37 ¹ / ₈ (941)	37 ¹ / ₈ (941)
H	42 ⁵ / ₈ (1082)	66 ³ / ₄ (1694)	90 ³ / ₄ (2305)	138 ⁷ / ₈ (3526)

Item	ID5SLR Merchandisers			
	4ft	6ft	8ft	12ft
A	6 ¹ / ₈ (155)			
B	58 ¹ / ₄ (1478)			
C	19 ¹ / ₈ (484)			
D	5 ¹ / ₈			
* E	12 ¹ / ₄ (309)	8 ¹ / ₈ (206)	12 ¹ / ₄ (309)	12 ¹ / ₄ (309)
* F	24 ⁷ / ₈ (631)	17 (430)	24 ⁷ / ₈ (631)	24 ⁷ / ₈ (631)
G	37 ¹ / ₈ (941)	25 ¹ / ₈ (636)	37 ¹ / ₈ (941)	37 ¹ / ₈ (941)
H	42 ⁵ / ₈ (1082)	66 ³ / ₄ (1694)	90 ³ / ₄ (2305)	138 ⁷ / ₈ (3526)

Insight® Single and Multideck Installation Information

Rear view dimensions ID5SLRS
cases with external sliding rear-loading doors
(4 ft, 6 ft, 8 ft, 12 ft)

Item	ID5SLRS Merchandisers			
	4 Ft	6 Ft	8 Ft	12 Ft
A	2 7/8 (74)			
B	64 1/8 (1628)			
C	16 3/8 (415)			
D	5 1/2 (139)			
E	37 1/8 (943)	25 1/8 (636)	37 1/8 (943)	37 1/8 (943)
F	11 (279)			
G	37 1/8 (943)	61 1/4 (1556)	85 1/4 (2165)	133 3/8 (3388)
H	48 1/8 (1222)	72 1/4 (1835)	96 1/4 (2445)	144 3/8 (3668)

Note: Consult Cooler Close-off Kit for instructions on connecting the merchandiser to the cooler.

Rear Views

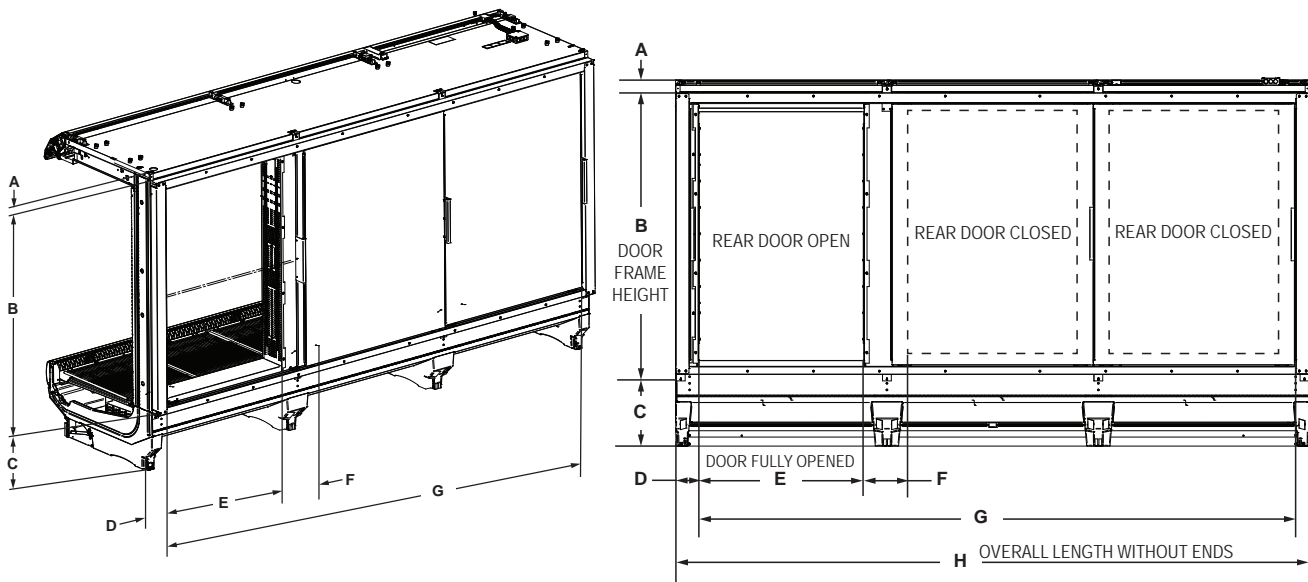

Dimensions shown as in. and (mm).

Insight® Single and Multideck Installation Information

Apply Gaskets - Rear-load
Refer to Page 23.

LEGEND:

- A = 1/2 x 1/2 inch gasket
- B = neutral curing silicone sealant
- C = pin-alignment
- D = cover-hand rail joint

Remove tie cable



IMPORTANT:

- Do not pull cases together with bolts. Cases must be moved together as close as possible. Follow sequence balloons to tighten bolts.
- Apply gasket to only one side of case joint
- Remove end shipping braces
- Cases must be leveled
- Remove any casters (if installed)
- Install case lineup from left to right
- Remove shelves, display racks, pans & interior back panels at the joining area
- Insert gasket into case channels the entire length with no gaps
- Do not stretch gasket, especially around corners
- Do not butt gaskets, always overlap them
- Remove paper backing after gasket has been applied
- Perimeter gasket is required by NSF
- Apply a continuous bead of neutral curing silicone sealant
- Joints must be air tight to prevent formation of ice of condensation

It is the installing contractor's responsibility to consult local agencies for local code requirements.



Insight® Single and Multideck Installation Information

Apply Gaskets - Doored Cases

Case bolting details begin on the next page. Refer to Page 21 for hardware list.

Do not pull cases together with bolts. Cases must be moved together as close as possible. Follow sequence balloons to tighten bolts.

LEGEND:

- A = 1/2 x 1/2 inch gasket
- B = neutral curing silicone sealant
- C = pin-alignment
- F = plate bottom door rail alignment

IMPORTANT:

- Do not pull cases together with bolts. Cases must be moved together as close as possible. Follow sequence balloons to tighten bolts.
- Apply gasket to only one side of case joint
- Remove end shipping braces
- Cases must be leveled
- Remove any casters (if installed)
- Install case lineup from left to right
- Remove shelves, display racks, pans & interior back panels at the joining area
- Insert gasket into case channels the entire length with no gaps
- Do not stretch gasket, especially around corners
- Do not butt gaskets, always overlap them
- Remove paper backing after gasket has been applied
- Perimeter gasket is required by NSF
- Apply a continuous bead of neutral curing silicone sealant
- Joints must be air tight to prevent formation of ice of condensation

It is the installing contractor's responsibility to consult local agencies for local code requirements.



Insight® Single and Multideck Installation Information

Case Joining Doored and Rear-load (door & rear-load cases) continued

LEGEND:

C = pin-alignment

F = plate-bott door rail alignment



1/4 X 3/4 CAP SCREW (11)

5/16 X 4 1/2 BOLT & ALIGNMENT CONE (2)

1/4 X 3/4 CAP SCREW (10)

5/16 X 4 1/2 BOLT & ALIGNMENT CONE (1)

(F)
(C)

5/16 X 7 BOLT & ALIGNMENT CONE (3)

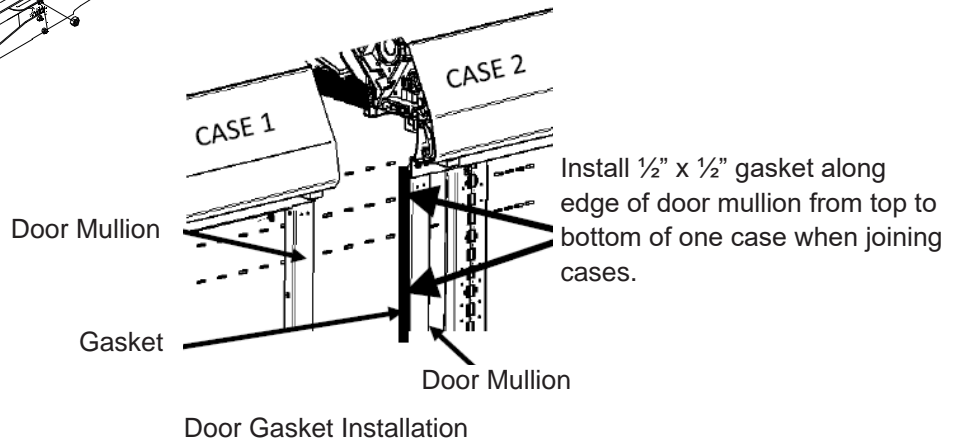

Insight® Single and Multideck Installation Information

Case Joining (door & rear-load cases)

This Bolt location is optional for some installed kits.



Insight® Single and Multideck Installation Information

Installing End Assemblies

Remove shipping brace. Brace screws will be replaced with shorter screws found in packout kit. Ensure nut retainers are in place. Apply Gaskets and Silicone to End Frame.

Apply ½ x ½ in. (12.7 mm) x (12.7 mm) gaskets into the case channels. Check that the gasket is properly inserted into the entire length of the channels with no gaps. Apply silicone between case end cap and end.

Field-Installed Hardware Description	Multideck Qty/Each	Convertible Qty/Each	Single Deck Qty/Each	View End Multideck Qty/Each
sealer silicone adhesive	1	1	1	1
gasket 1/2 x 1/2 x 180	1	1	1	1
screw sm 10-16x3/4 hx washer	1	1	1	N/A
bolt 5/16 x 2 3/4 grade 5 zinc plated tap*	4	2	1	5
bolt- tap, 5/16 x 4 1/2, steel, zinc finish, gr5	1	1	1	1
washer-flat 5/16" zinc*	7	4	2	8
nut-hex 5/16 steel zinc finish grade 8*	3	2	2	4
nut-push 5/16" retainer steel zinc*	2	1	1	2
nut-j retainer 5/16*	2	1	N/A	2
button-plug 7/8 dia*	5	3	2	6

*Quantities may vary depending on which type of end is to be placed on case.



IMPORTANT:

- Do not pull cases together with bolts. Cases must be moved together as close as possible. Follow sequence balloons to tighten bolts.
- Apply gasket to only one side of case joint
- Remove end shipping braces
- Cases must be leveled
- Remove any casters (if installed)
- Install case lineup from left to right
- Remove shelves, display racks, pans & interior back panels at the joining area
- Insert gasket into case channels the entire length with no gaps
- Do not stretch gasket, especially around corners
- Do not butt gaskets, always overlap them
- Remove paper backing after gasket has been applied
- Perimeter gasket is required by NSF
- Apply a continuous bead of neutral curing silicone sealant
- Joints must be air tight to prevent formation of ice or condensation

It is the installing contractor's responsibility to consult local agencies for local code requirements.

Insight® Single and Multideck Installation Information

**Case End Installation
multideck (rear-load & door)
refer to detail views**

LEGEND:

A = 1/2 x 1/2 inch gasket

B = neutral curing silicone sealant

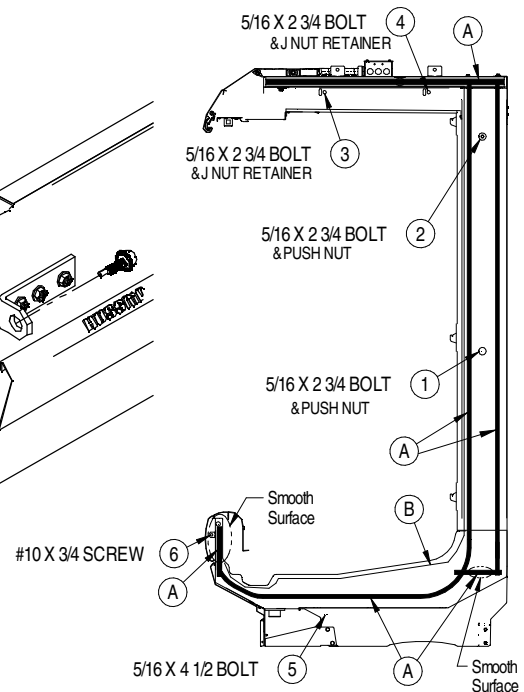
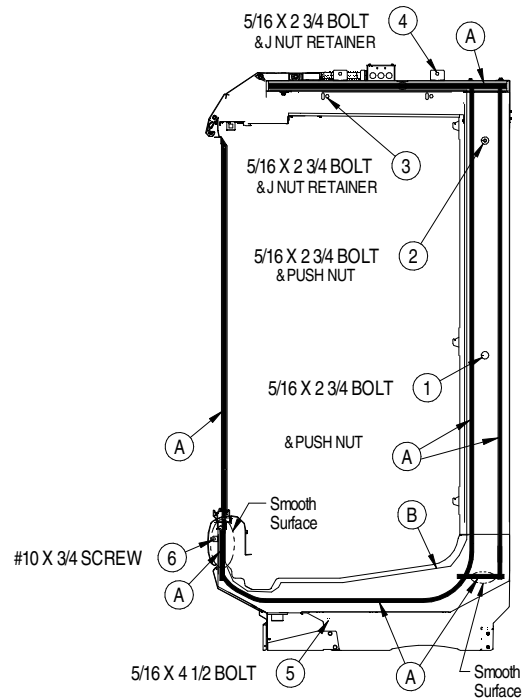
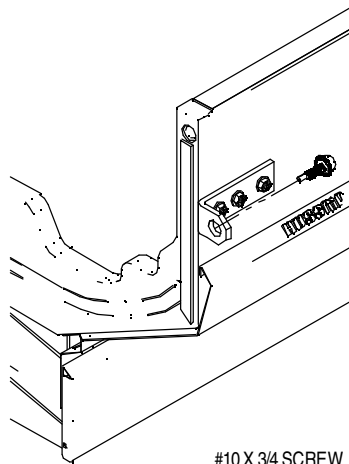

Insight® Single and Multideck Installation Information

Case View End Installation Multideck (REAR-LOAD & DOOR) Refer to detail views

LEGEND:

A = 1/2 x 1/2 inch gasket

B = neutral curing silicone sealant

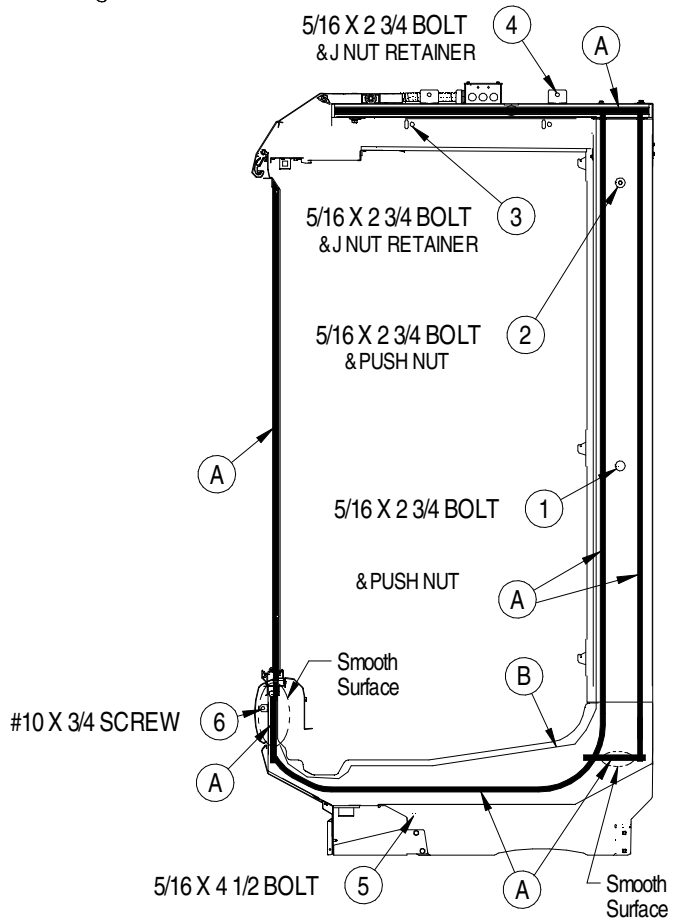

Insight® Single and Multideck Installation Information

Convertible Case End Installation Refer to detail views

LEGEND:

A = 1/2 x 1/2 inch gasket

B = neutral curing silicone sealant



Insight® Single and Multideck Installation Information

Singe Deck Case End Installation Refer to detail views

LEGEND:

A = 1/2 x 1/2 inch gasket

B = neutral curing silicone sealant



Insight® Single and Multideck Installation Information

Installing Partitions

Remove shipping brace. Brace screws will be replaced with shorter screws found in packout kit. Ensure Nut Retainers are in place. Apply Gaskets and Silicone to End Frame.

Apply ½ x ½ in. (12.7 mm) x (12.7 mm) gaskets into the case channels. Check that the gasket is properly inserted into the entire length of the channels with no gaps. Apply silicone between case end cap and end.

Description	Alt Canopy Applications	Multi Deck/Door Same Case Qty/ Each	Multi Deck/Door Different Case Qty/Each	Convertible Different Case Qty/Each
sealer silicone adhesive	refer to multideck different case	2	2	2
gasket 1/2 x 1/2 x 180	refer to multideck different case	2	2	2
screw-sheet metal #8 x 5/8 phil hx hd	3 or 4	1	1	1
screwsm10-16x3/4 hx washer	1	2	2	2
bolt hex 1/4 x 1 1/2	refer to multideck different case	n/a	2	n/a
bolt hex 1/4 x 2 1/4*	1	n/a	2	2
bolt hex 1/4 x 4.0	refer to multideck different case	n/a	1	n/a
bolt hex 5/16 x 2 3/4*	refer to multideck different case	1	4	2
bolt-hex 5/16 x 4 1/2	refer to multideck different case	2	1	n/a
bolt-hex 5/16 x 7.0*	refer to multideck different case	2	n/a	n/a
bolt-hex 5/16 x 8.0	refer to multideck different case	1	n/a	1
washer-flat 1/4*	1	n/a	5	2
washer-flat 5/16*	refer to multideck different case	8	5	4
nut-hex 5/16*	refer to multideck different case	7	3	4
nut-hex 3/8-24 serrated flange	1	4	2	n/a
nut-push 5/16" retainersteel zinc*	refer to multideck different case	2	n/a	n/a
nut-j retainer 5/16*	refer to multideck different case	1	2	1
bracket-case joining	n/a	4	2	n/a
bracket-canopy (alt applications)	1	n/a	n/a	n/a
bracket-unibody (alt applications)	1	n/a	n/a	n/a
button-plug7/8 dia*	refer to multi deck different case	n/a	2	1
bracket-closeoff splashguard	refer to multi deck different case	1	1	1
closeoff-splashguard	refer to multi deck different case	1	1	1

*Quantities may vary depending on which type of end is to be placed on case.



Insight® Single and Multideck Installation Information

Same Case Partitions
multideck (rear-load & door)
refer to detail views.

LEGEND:

A = 1/2 x 1/2 inch gasket

B = neutral curing silicone sealant

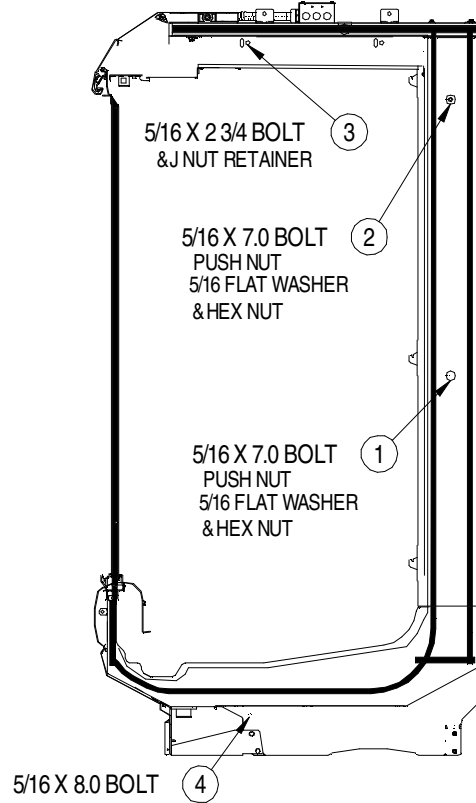

Insight® Single and Multideck Installation Information

**Multideck (rear-load & door)
same case partitions continued**

Refer to detail views.

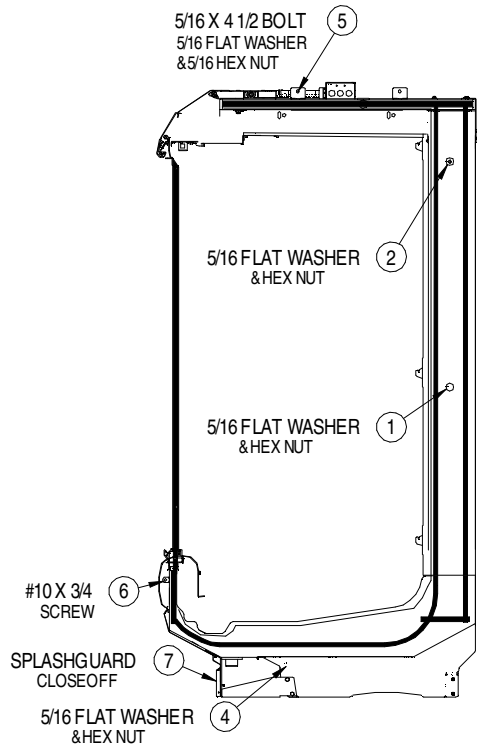

Insight® Single and Multideck Installation Information

Different case partitions
multideck (rear-load & door)
Refer to detail views.

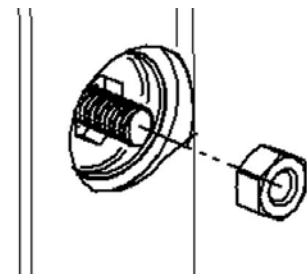
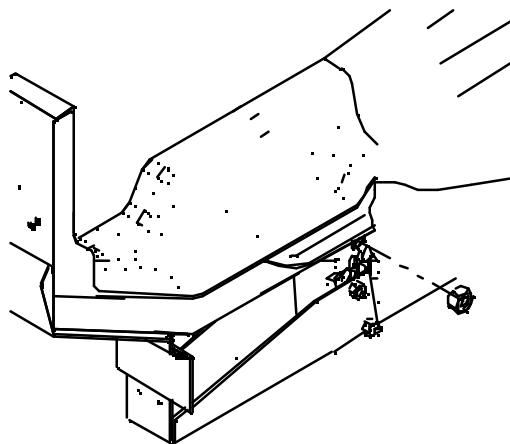
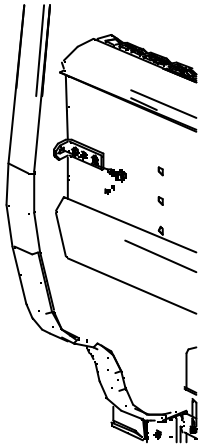
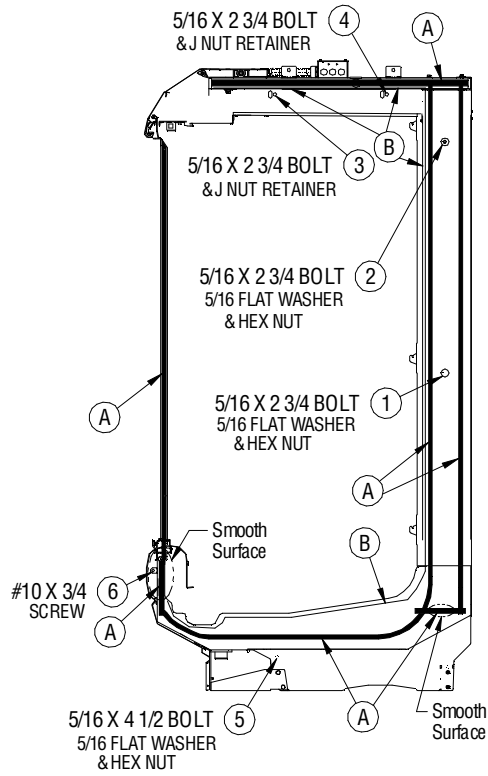
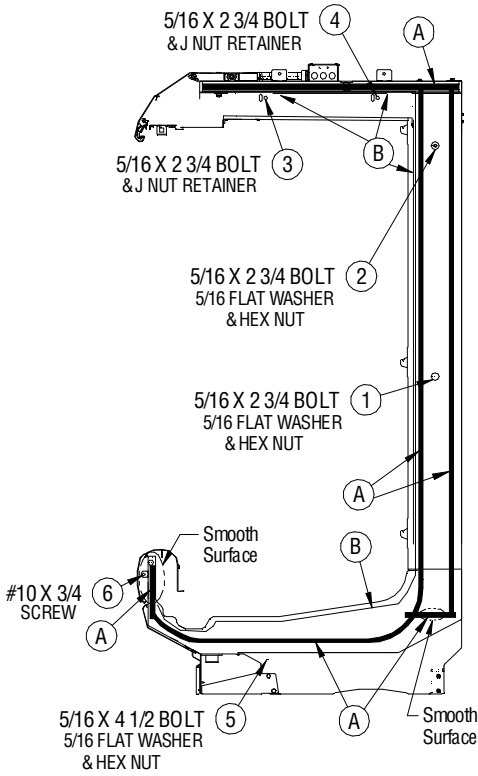
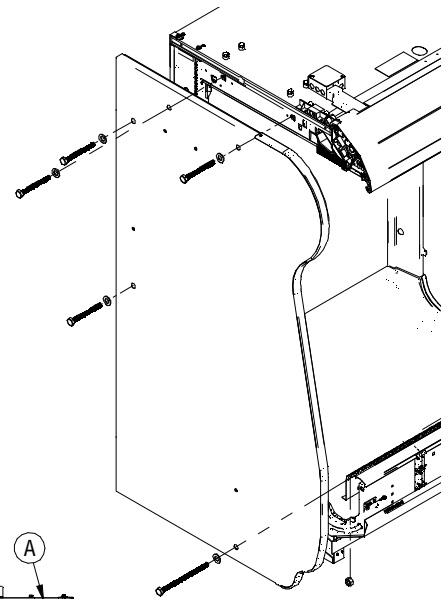

Insight® Single and Multideck Installation Information

Multideck (rear-load & door) different case partitions continued

Refer to detail views.

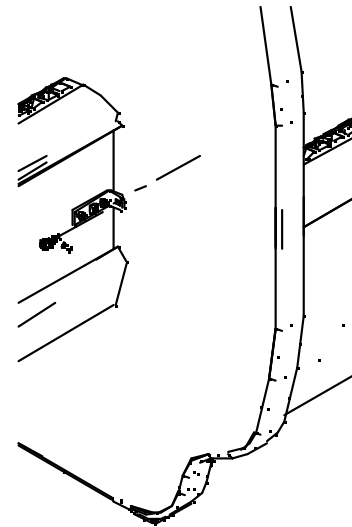
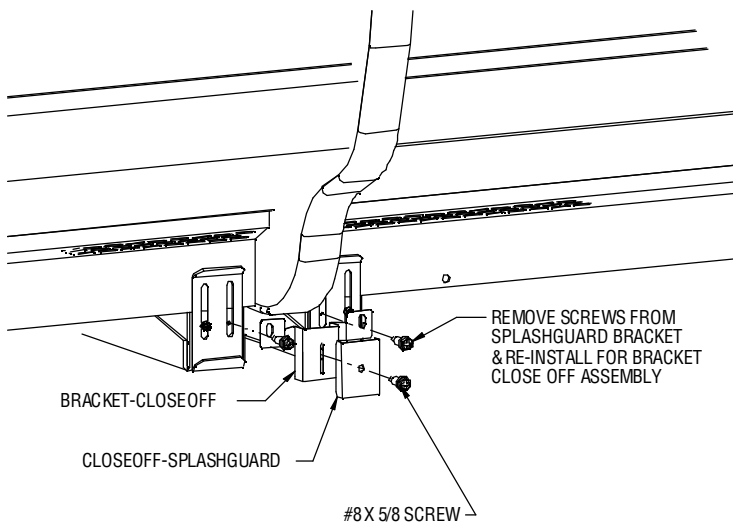
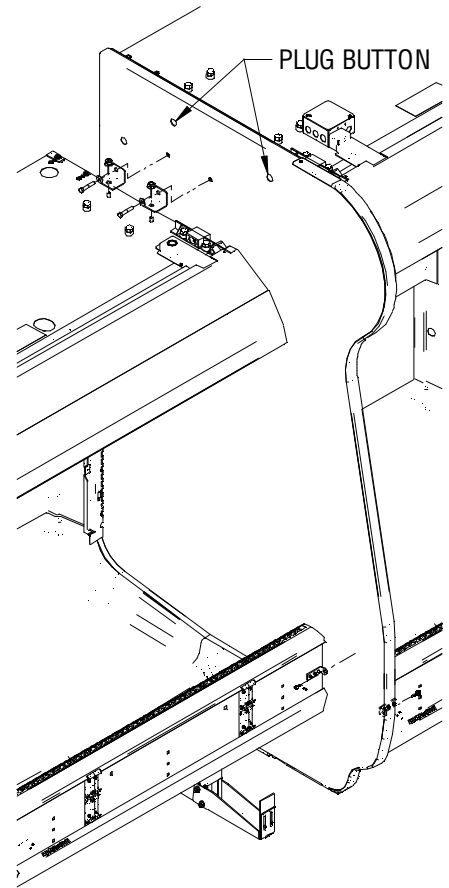
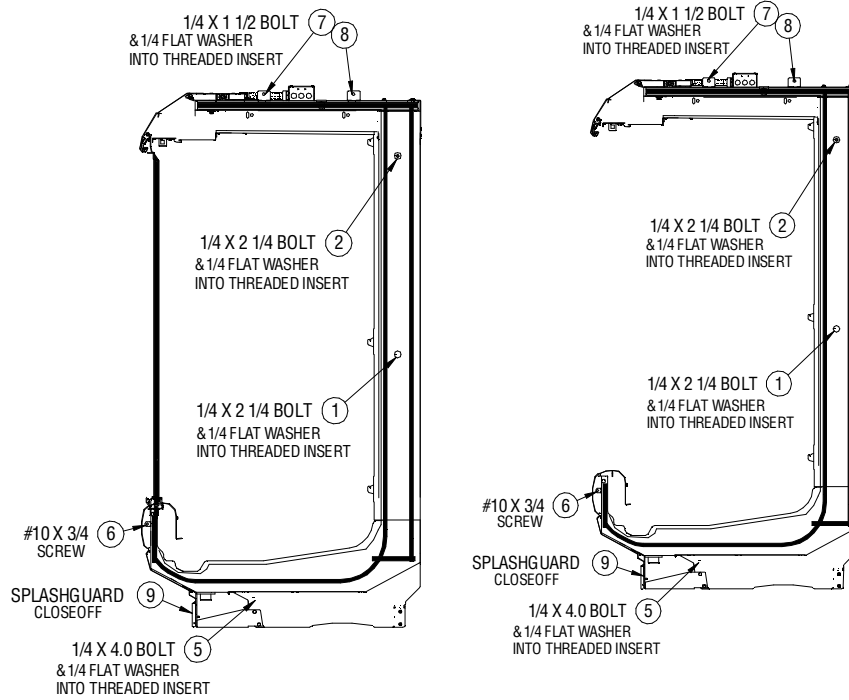

Insight® Single and Multideck Installation Information

Different case partitions multideck (rear-load & door)
alternative canopy applications continued

Refer to detail views.



Insight® Single and Multideck Installation Information

Convertible different case partitions

Refer to detail views.

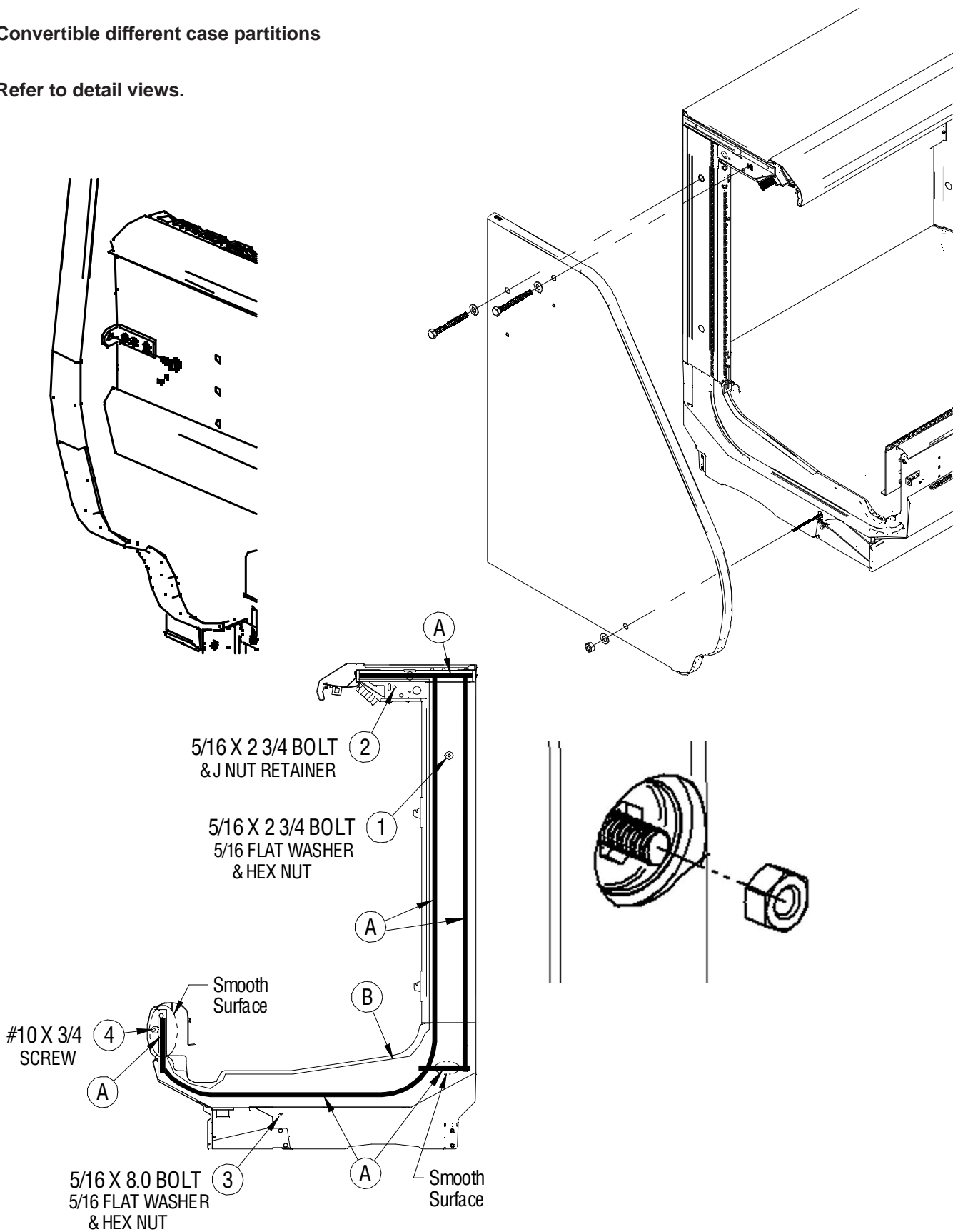

Insight® Single and Multideck Installation Information

Convertible different case partitions continued

Refer to detail views.

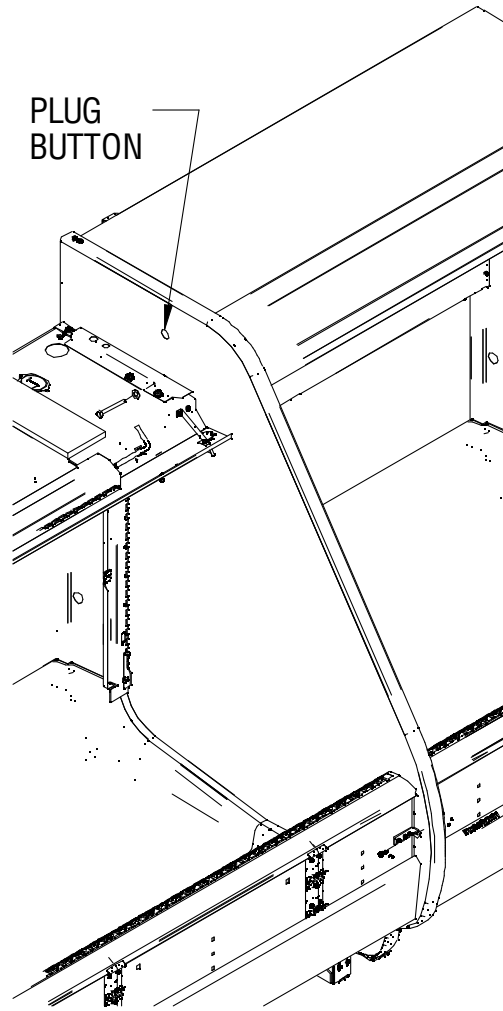



Insight® Single and Multideck Installation Information



Acrylic Partition Hardware

Description	Multi Deck Qty/Each	Convertible Qty/Each
partition-acrylic	1	1
bracket-canopy	1	1
bracket-return air grille	n/a	1
screws #8 x 5/8 hex	3	4
screwmachine #8 x 1/2 philips	3	4
lockwasher #8 ext tooth	3	4
nut #8 machine hex	3	4

screw-sheet metal #8 x 5/8  

screw-machine #8 x 1/2 philips  

lockwasher-ext tooth #8  

nut machine hex-#8  

bracket-canopy multideck



bracket-canopy convertible



bracket-return air grill



partition-acrylic



Insight® Single and Multideck Installation Information

Acrylic Partitions - Multideck

Refer to detail views.



Insight® Single and Multideck Installation Information

Convertible Acrylic Partitions

Refer to detail views.

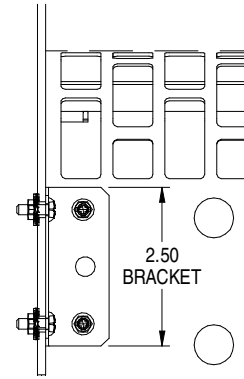

RETURN AIR GRILL VIEW
APPROXIMATE LOCATION
OF BRACKET



Insight® Single and Multideck Installation Information

Installing Splashguard Brackets

Position splashguard brackets at the front base (legs) of the merchandiser near the floor. Loosely assemble Splashguard Bracket using #8 x 5/8 inch SM screws as shown in Detail A below. More detail of splashguard installation shown on next page.

WARNING

Use caution when working around refrigeration lines or water lines. Damage to equipment and/or personal injury could occur.

NOTE End Splashguard Panel fits to the inside of End Assembly.
Install end splashguard before installing front splashguards.

Splashguard Bracket and Panel Installation (12 ft Shown)



Insight® Single and Multideck Installation Information

Installing Splashguard Brackets Ultra-Low Front Cases

Position splashguard brackets at the front base (legs) of the merchandiser near the floor. Loosely assemble Splashguard Bracket using #8 x 5/8 inch SM screws as shown in Detail A below.

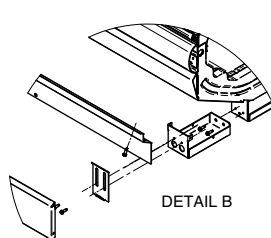

Insight® Single and Multideck Installation Information

Installing Night Blinds

STEP 1

Slide the lefthand night blind into bracket cutout.

NOTE Left section of case always uses the front cutout. Alternate front to back for remaining sections.



STEP 2

Swing righthand side of night blind into slot on side of canopy support arm.

NOTE Left section of case always uses the bottom slot. Alternate bottom to top for remaining sections.



Detail A
Brackets Always on Left Side of Night Curtain

STEP 3

Push/pull down on night blind slightly to slide pin past detent.

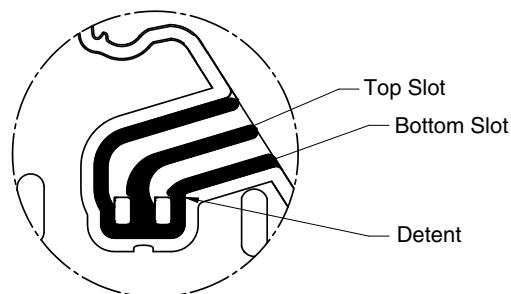

Detail B
Slots always on right side of night blind

STEP 4

Check pin engagement to ensure at least 3/16" of pin is firmly in the slot.



Insight® Single and Multideck Installation Information

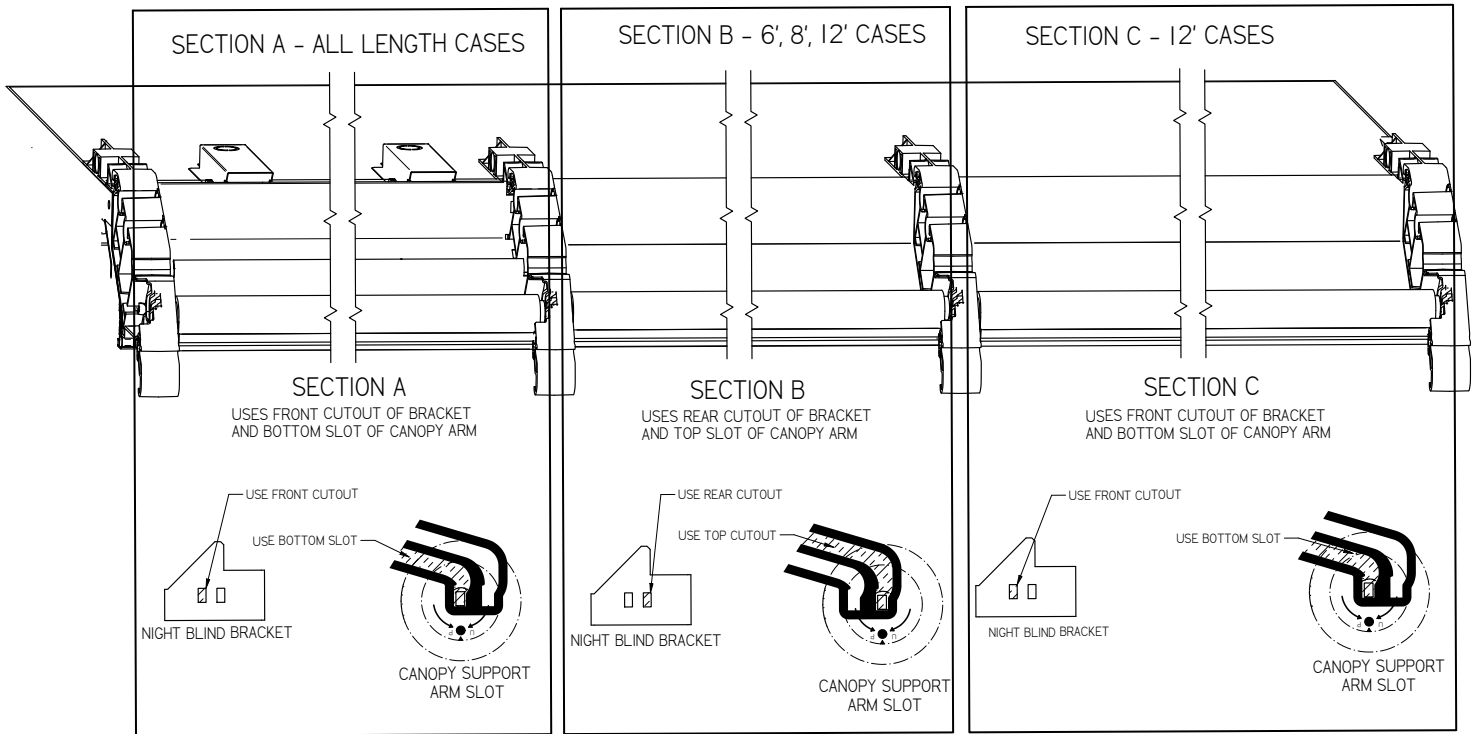

Insight® Single and Multideck Installation Information

Loading Blind Spring

Night blinds are delivered preloaded. However, if it is necessary to load night blind spring, use a wrench (part number [0477098](#)) to twist rectangular pin on right side of night blind. Twist clockwise 14 to 15 full revolutions.

NOTE  Keep arrow / dot / up pointed up while winding. Keep pointed down when installed.

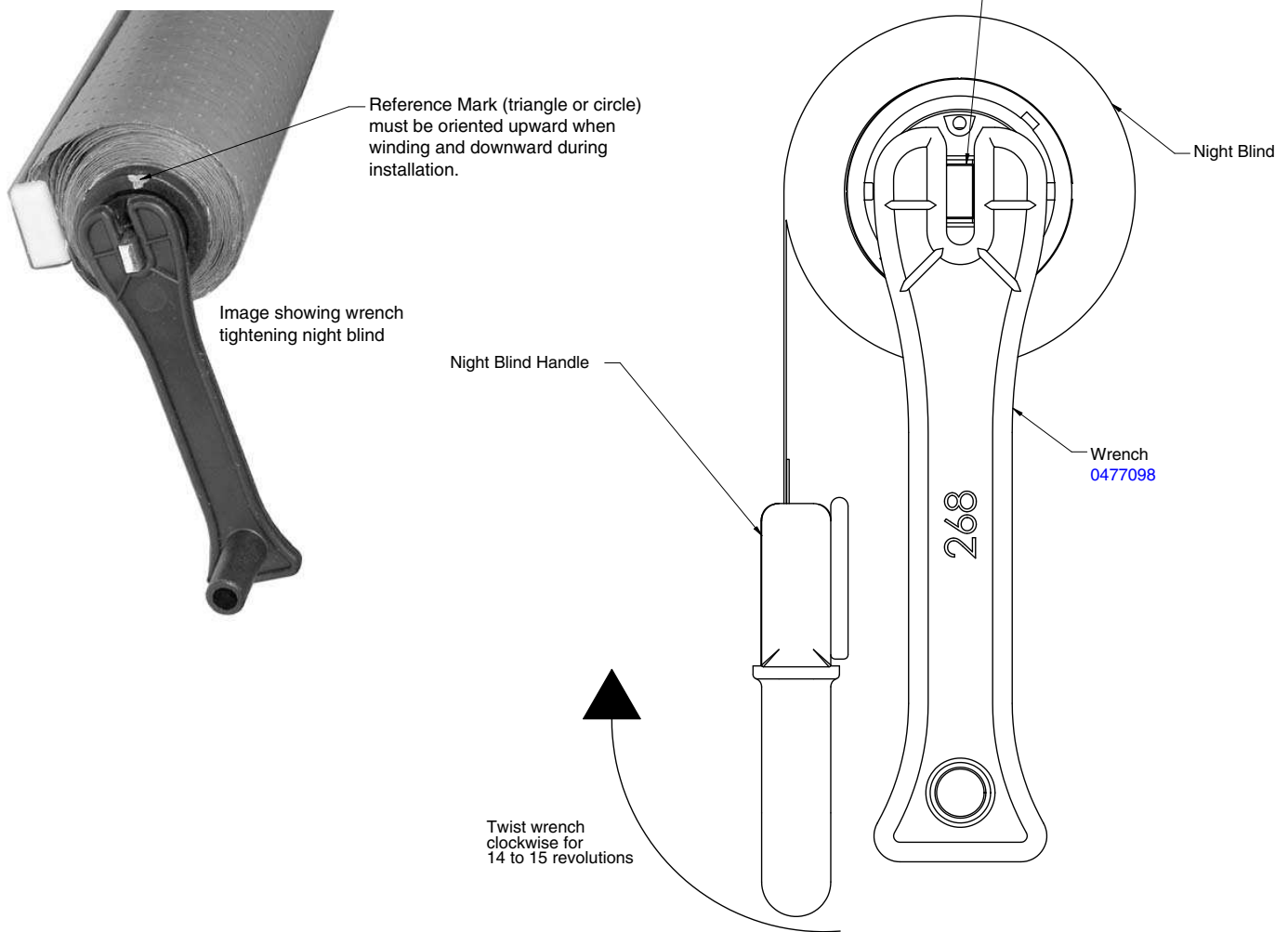

Insight® Single and Multideck Installation Information

Troubleshooting Night Blinds

If night blind is not installed:

STEP 1

Only install brackets on the lefthand support arm and each center support arm.

STEP 2

On the righthand side of each arm, insert front tab of bracket into the front slot, then snap into the rear slot.



If pin is too short or rounding out canopy arm:

STEP 1

Remove night curtain from case.

NOTE

Keep pointed down when installed.

STEP 2

Use pliers to pull metal pin out to desired length.

STEP 3

Replace night curtain into canopy

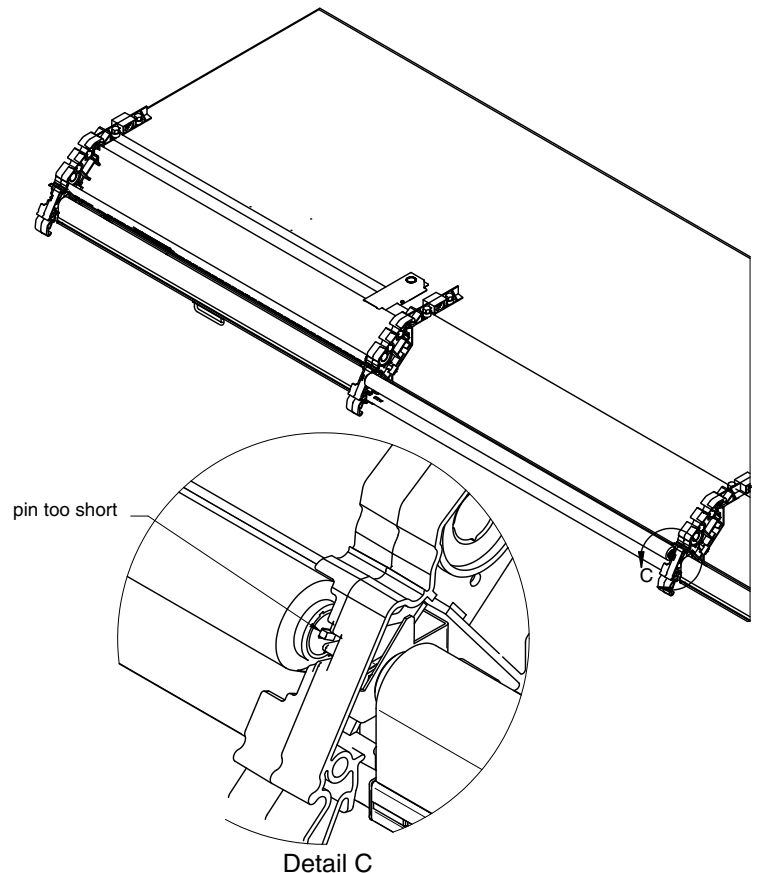

Insight® Single and Multideck Installation Information

Doors - Installing, Removing, Adjusting

1. To install a door: Lean door back, and push pin into mullion. Ensure push pins are fully seated in canopy support bracket.
2. To remove a door: Raise door up and lift rod bottom out of bottom hinge plate hole

Adjusting EcoVision Doors

Check that all doors open and close properly.

1. Leveling — Merchandisers must be installed level to ensure proper operation of the refrigeration system, and to ensure proper drainage of defrost water.

Glass alignment is also affected with improper leveling of the merchandisers. All steps of setting joining and case leveling attention to the glass position is critical. Do not attempt to make glass adjustments prior to case leveling.

2. Door Adjustment — Loosen the screws A, B and C as shown below (Do not remove the screws completely).

Slide the bottom plate left and right until proper alignment is achieved. Re-tighten the screws A, B and C. Install fasteners in locations 1 and 2 as shown below.



Excessive ambient conditions may cause condensation and therefore sweating of doors. Facility operators should monitor doors and floor conditions to ensure safety of persons.

EcoVision Door Alignment - Modular Bottom Hinge Plate



To Correct Shift the Bottom Plate to the Right

To Correct Shift the Bottom Plate to the Left

Insight® Single and Multideck Installation Information

Adjusting Door Closing Speed

The door's closing speed is factory adjusted, but the door may also be field adjusted.

Do the following to adjust the doors:

1. To release door tension, open the door to 90° and lift up the door from the bottom. Lift the torsion rod out of the star pattern in the bottom hinge plate. (The door should be lifted out of the star pattern in the hinge plate to prevent any damage to the star pattern.)
2. Use a ½ in. open end wrench to tighten the torsion of the door. Adjust tension with each audible click. Doors should be adjusted to 4 clicks, more if needed. Door must be properly resealed in star pattern of hinge plate after torsion tension is applied.



Insight® Single and Multideck

Installation Information

Piping Overview

Important: Since Hussmann has no direct control over the installation, providing freeze-burst protection is the responsibility of the installing contractor.

System design must conform to all local and national codes, laws, and regulations applying to the site of installation. In addition, the safety code for mechanical refrigeration (ASME B31.5) should be followed as a guide for installation and operation practice.

Refrigerant line sizes and piping techniques should be obtained from the ASHRAE guide or equivalent reference. Under no circumstances should the refrigerant connection size of the equipment be used as the basis for sizing the lines.

The horizontal suction line should slope away from the equipment toward the compressor. Vertical suction risers may require a trap at the bottom of the riser for proper oil return.

CO₂ Piping

Piping

Any piping material that meets all pressure and temperature ratings, material compatibility requirements and state and local building codes may be used for pumped liquid CO₂ applications. The design pressure of the system is labeled on the unit. Any connected components must meet the system design pressure (e.g., 1,305 psig [90 bar]).

Approved joining methods must be used for all piping and fittings to ensure the pipe's maximum pressure rating is maintained without reduction. The use roll-stop couplings for straight line pipe joints are recommended. Swaging of pipe joints is not recommended. Swaging weakens the copper at the swage point, reducing the maximum operating pressure rating.

CO₂ Piping Material

- Piping—minimum design pressure greater than system design pressure (e.g., 1,305 psig [90 bar])
- Fittings—Mueller Streamline XHP CuFe 1,885 psig (130 bar)
- Braze joints with alloy containing 15% silver (minimum)
 - Flux materials must contain no zinc and must also be water soluble
 - All field piping must be purged with nitrogen while brazing
- Schedule 40 carbon steel pipe or stainless-steel pipe
 - Must protect exterior from corrosion

Insulation

Insulation should be used in secondary system piping to reduce the heat transfer to ambient air and to maintain subcooling in the CO₂ liquid supply line to the case. The insulation should be sized to allow for the worst-case conditions of heating from store lighting and ambient temperatures. Pipe should be insulated according to local codes and customer specifications and manufacturer specifications.

When installing piping that has not been pre-insulated, there are several options for insulation. Closed-cell elastomeric insulation is extremely popular in refrigeration applications. This type of insulation can also be used in secondary system applications.

The manufacturer's internal case piping valves and components are insulated to prevent frost from building. Sufficient insulation is required on piping into the display case to eliminate frost on tubes and to minimize temperature rise of CO₂.

Insight® Single and Multideck

Installation Information

Check Valves

Check valves are required wherever there is a possibility of trapping liquid CO₂ between valves that may be shut off, including solenoid valves, service valves, and balancing valves. Check valves must be installed to vent high pressure CO₂ back to the system. Hussmann recommends reverse return tubing instead of the use of shutoff valves for balancing purposes, but if shutoff valves are used, they must be relieved to the system through check valves.

WARNING—Trapping of liquid CO₂ can result in extremely high pressure and must be avoided to prevent damage to equipment and personal injury.

Solenoid, check, ball valves, and ball valves with integrated pressure relief must be qualified for CO₂ applications, with a minimum design pressure equal to or greater than the equipment design pressure (e.g., 1,305 psig [90 bar]).

Pumped Liquid R-744 (CO₂) Supply Piping

For systems utilizing pumped liquid CO₂, the liquid supply lines should be sized using the same guidelines as liquid lines. However, it is crucial to recognize that CO₂-pumped liquid is more resistant to pressure drop than standard liquid lines. The CO₂ pump introduces mechanical subcooling, enabling a higher pressure drop before the liquid begins to vaporize.

To ensure optimal performance, a system analysis is necessary to determine the maximum permissible pressure drop in both the supply and return lines. The combined pressure drop in the recirculation lines, the pressure drop across all system components, and any pressure changes due to elevation differences should not exceed the specified pressure differential rating of the pump.

Pumped Liquid R-744 (CO₂) Return Piping

For systems utilizing pumped liquid CO₂, the liquid return lines will carry a mixture of both liquid and vapor, with the exact ratio determined by the liquid overfeed rate. A system analysis must be conducted to identify the maximum permissible pressure drop in both the supply and return lines. The total pressure drop across the recirculation lines, all system components, and any changes in pressure due to elevation must not exceed the rated pressure differential of the pump.

It is essential to avoid over-sizing the liquid return riser lines. If the velocity becomes too low, liquid and vapor phases may separate, causing a significant increase in pressure drop as liquid accumulates in the vertical riser.

In pumped liquid CO₂ systems, the liquid temperature typically falls below 30° F (-1.1° C). Therefore, it is essential to adequately insulate these lines to prevent condensation and minimize heat absorption. Failure to properly insulate liquid lines can reduce the cooling capacity, leading to suboptimal system performance.

Application data for display cases can be found at Hussmann.com

Insight® Single and Multideck

Installation Information

Additional Piping Installation Requirements

- Installation shall include protection from physical damage in operation and service and be in compliance with national and local codes and standards, such as ANSI/ASHRAE 15, IAPMO Uniform Mechanical Code, ICC International Mechanical Code, or CSA B52. All field joints shall be accessible for inspection prior to being covered or enclosed.
- The installation of pipework shall be kept to a minimum.
- A brazed, welded, or mechanical connection shall be made before opening the valves to permit refrigerant to flow between the refrigerating system parts.
- Mechanical connectors used indoors shall comply with ISO 14903 or UL 207 or CSA C22.2 No. 140.3. When mechanical connectors are reused indoors, sealing parts shall be renewed. When flared joints are reused indoors, the flare part shall be refabricated.
- Refrigerant tubing shall be protected or enclosed to avoid damage. Flexible refrigerant connectors (such as connecting lines between an indoor and outdoor unit) that might be displaced during normal operation shall be protected against mechanical damage.
- Mechanical connections shall be accessible for maintenance purposes.
- Provision shall be made for expansion and contraction of long runs of piping.
- Protection devices, piping, and fittings shall be protected as far as possible against adverse environmental effects, for example, the danger of water collecting and freezing in relief pipes or the accumulation of dirt and debris.
- Piping in refrigeration systems shall be so designed and installed to minimize the likelihood of hydraulic shock damaging the system.
- Steel pipes and components shall be protected against corrosion with a rustproof coating before applying any insulation.
- Flexible pipe elements shall be protected against mechanical damage, excessive stress by torsion, or other forces, and they should be checked for mechanical damage annually.
- Precautions shall be taken to avoid excessive vibration or pulsation of the refrigerant piping.
- Look for the room area label on the equipment to identify the minimum room size. The information in this manual can also be used as an estimate. Always confirm the exact value on the equipment before installation.
- After completion of field piping for split systems, the field pipework shall be pressure tested with an inert gas and then vacuum tested prior to refrigerant charging, according to the following requirements as detailed by UL safety standard. Pressures may come from equipment data label or from customer specification.
 1. The minimum test pressure for the low side of the system shall be the low side design pressure and the minimum test pressure for the high side of the system shall be the high side design pressure, unless the high side of the system cannot be isolated from the low side of the system in which case the entire system shall be pressure tested to the low side design pressure.
 2. The test pressure after removal of the pressure source shall be maintained for at least 1 hour with no decrease of pressure indicated by the test gauge, with rest gauge resolution not exceeding 5% of the test pressure.
 3. During the evacuation test, after achieving a vacuum level specified in the manual or less, the refrigeration system shall be isolated from the vacuum pump and the pressure shall not rise above 1500 microns within 10 min.

Insight® Single and Multideck

Installation Information

- Field-made refrigerant joints indoors shall be tightness tested according to applicable codes and requirements. The test method shall have a sensitivity of 0.18 oz (5 g) per year of refrigerant or better under a pressure of at least 0.25 times the maximum allowable pressure. No leak shall be detected.
- Equipment piping in the occupied space shall be installed in such a way to protect against accidental damage in operation and service.
- Any solenoid valves shall be correctly positioned in the piping to avoid hydraulic shock or pressure.
- Insulation shall be suitable for use with the material being insulated.
- The indoor equipment and pipes shall be securely mounted and guarded such that accidental rupture of equipment cannot occur from such events as moving furniture or reconstruction activities.

Line Connection Sizes

Consult the unit datasheet or contact a Hussmann representative for unit-specific line size inquiries.

Waste Outlet/Drain Line

All information about waste/drain setup required to install and ensure proper function.

Refrigerant Piping

Standard Connection Locations

Standard refrigerant line connections are at the right end of the merchandiser (as viewed from the front) beneath the display pans. The installer must saw a hole to exit the case. After connections have been made, thoroughly seal this outlet. Seal both the inside and the outside.

It is recommended to use an expanding polyurethane foam insulation. Cover foam with silicone to prevent water from entering foam. Refrigerant lines must not interfere with the drain covers. Drain covers must be removed to provide access for cleaning.



Drain Cover



Piping Outlet

Insight® Single and Multideck

A2L Piping Connection Locations

A2L cases are piped to the outside of the case. For taller models (4-, 5-, and 6-deck), the piping connections are located on the top-right side of the case.



For A2L short cases (1, 2, and 3-deck), piping connections are located underneath the case on the right side.

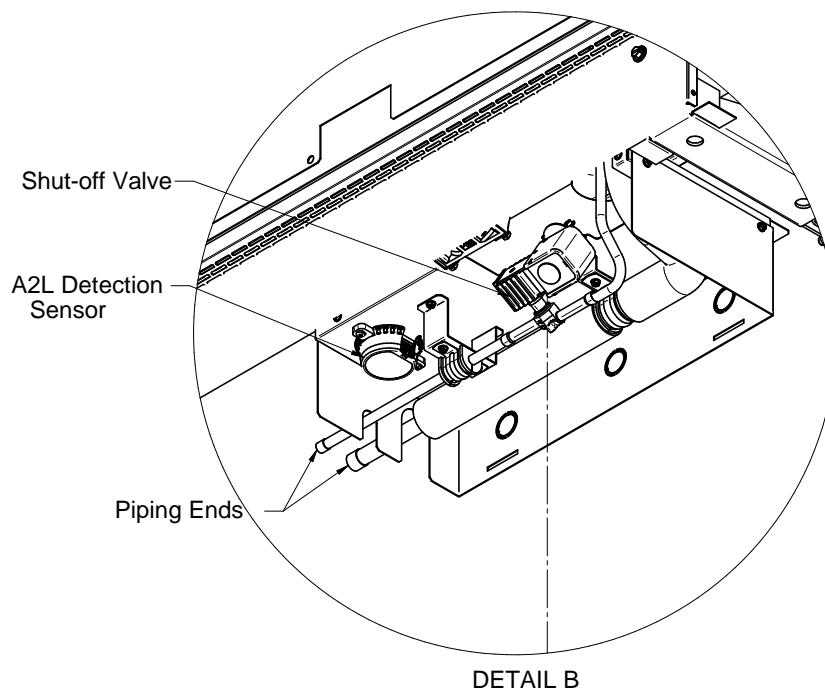

Insight® Single and Multideck Installation Information

Back Wall Piping Penetrations (Optional)

For cases with A2L refrigerant, back wall piping is not allowed. Cases that are to be piped from the back have a factory installed $\frac{1}{4}$ in. pilot hole in the exterior liner. Use the pilot hole to locate the hole saw to drill out a hole $2\frac{1}{2}$ in. diameter hole to run the coil piping.

After connections have been made, thoroughly seal this outlet. Seal both the inside and the outside.

It is recommended to use an expanding polyurethane foam insulation. Cover foam with silicone to prevent water from entering foam.

CAUTION

When brazing pipes be sure to use the insulation blanket shipped with the merchandiser to prevent damage to the foam bottom.



Insight® Single and Multideck Installation Information

Narrow and Wedge Case Connection use Shroud

A shroud should be used to seal pipe penetrations in the bottom liner for narrow Insight cases as well as wedge cases. Saw a hole through the bottom liner that is large enough to fit the refrigerant piping. Place the refrigeration shroud over refrigeration piping so that when the shroud is rotated into place, it will be in the upright position. Use the supplied refrigeration brazing blanket to avoid burning the liner. Be careful not to burn, scorch or over-heat the shroud when making connections

Attach the shroud to the liner using 8 supplied screws. Apply a continuous bead of silicone sealant around the bottom of the shroud after all connections are made and insulation has been applied to the piping. Seal the outlet thoroughly. Seal both the inside and outside. Hussmann recommends using expanding polyurethane foam insulation. Cover foam with silicone to ensure seal around insulation and to prevent deterioration of foam.

Note: Wedge cases get sheet metal screws, narrow cases use plastic screws.

Multiplexing

Piping of merchandisers operating on the same refrigeration system may be run from merchandiser to case. Do not run refrigerant lines through merchandisers that are not on the same refrigeration system branch as this may result in poor refrigeration control and compressor failure. Interconnecting piping inside the case must be located as shown below to allow room for lifting the hinged fan plenums and for clearance beneath the display pans. Alternately, the interconnecting piping may be run outside the case.

Line Sizing: Refrigerant lines should be sized as shown on the refrigeration legend that is furnished for the store or according to ASHRAE guidelines. Refer to the information on the next page for branch line piping of Hussmann Equipment.

Oil Traps: P-traps (oil traps) must be installed at the base of all suction line vertical risers.

Pressure Drop: Pressure drop can rob the system of capacity. To keep the pressure drop to a minimum, keep the refrigerant line run as short as possible using a minimum number of elbows. Where elbows are required, use long radius elbows only.

Insulation

Additional insulation for the balance of the liquid and suction lines is recommended wherever condensation is objectionable or lines are exposed to ambient conditions.

Suction Line

- Pitch in direction of flow.
- May be reduced by one size at one third of merchandiser run load and again after the second third. Do not reduce below the merchandiser suction line size.
- Merchandiser suction lines should enter at the top of the branch line.



Suction Line Return

Liquid Line

May be reduced by one size after one half the merchandiser run load. Do not reduce below the merchandiser liquid line connection size.

Take-offs to merchandiser liquid lines should exit the bottom of the branch liquid line. Provide an expansion loop for each evaporator take-off (minimum 3 inches [76 mm] loop).



Minimum Loop
3-in. (76 mm)

Liquid Line Take Off

Insight® Single and Multideck Installation Information

Waste Outlet / Drain Line

Water seals are field installed with waste outlet to prevent air leakage and insect entrance into the case. Tees and clean-outs are supplied for each case. A hat-shaped strainer is also shipped with the merchandiser. Place strainer over the waste outlet as shown below. The waste outlet location varies for each of the 1, 2, 3, 4, and 5-door merchandisers. Drip piping is located between the front merchandiser base and the splashguard fixture and runs parallel to the merchandiser (see datasheet for exact locations).



Insight® Single and Multideck Installation Information

Installing Drip Piping

Poorly or improperly installed drip pipes can seriously interfere with the merchandiser's operation and result in costly maintenance and product losses. Please follow the recommendations listed below when installing drip pipes to ensure proper installation. Drip piping must be installed before piping merchandiser. It is the installing contractor's responsibility to consult local agencies for local code requirements.

- Pitch the drip piping in the direction of flow. There should be a minimum pitch of ¼ in. per ft (20 mm per 1 m). Never use drip piping smaller than the nominal diameter of the pipe or water seal supplied with the merchandiser.
- Assemble the components using field-supplied PVC primer and glue according to the manufacturers direction. All connections must be watertight and sealed with the appropriate PVC or ABS cement.
- Avoid long runs of drip piping. Long runs make it impossible to provide the pitch necessary for good drainage. Ensure that drip piping is supported to relieve any stress on drip pipe connectors and drain hub. Drip piping **MUST** be supported no more than 24 in. from drain hub tee.
- When connecting drip piping, the water seal must be used as part of the drip piping to prevent air leakage or insect entrance. Never use two water seals in series in any one drip pipe. Double water seals in series will cause an air lock and prevent draining.
- Provide a suitable air break between flood rim of the floor drain and outlet of drip pipe. For low base merchandisers, it may be necessary to install a field-supplied drip pipe reducer. An alternative is to cut the last section of drip pipe at an angle.
- Prevent drip pipes from freezing sweating or freezing:
 - a. Do NOT install drip pipes in contact with uninsulated suction lines. Suction lines should be insulated with a non-absorbent insulation material.
 - b. Where drip pipes are located in dead air spaces, such as between merchandisers or between a merchandiser and a store wall, provide means to prevent drip pipe from sweating. External ventilation fans may be required to prevent sweating.



Drip Piping Example for Standard Case Height
(Not for Ultra Low Front Cases)



Insight® Single and Multideck

Installation Information

Drain Trap

1. Tee is factory-installed. Do not overtighten threads, or the drain fitting or tee may become damaged.
2. Do NOT use thread sealer on ABS drain fitting. If sealer is used the ABS drain fitting may crack or leak! (If a tee needs to be installed it should be tightened no more than 4 turns.) Do not overtighten threads.
3. Dry fit the supplied water seal / trap to ensure approximately 1/2 in. (13 mm) of clearance from the bottom of the trap to the floor as shown.
4. Install remaining PVC drain parts using recommended PVC cleaner, primer and cement per manufacturer's recommendations.
5. Thread plug into the adapter until snug but not to exceed four full rotations.
6. Installed drip piping may require additional support depending on the number and location of the hub floor drains. The installer should always provide adequate support to all drip piping arrangements to prevent excess stress on all drip piping components. The installer must provide additional support when "evac" type waste water systems are applied.

Note: It may be necessary to rotate water seal (trap) inside the tee a few degrees to ensure clearance at two locations. There must be clearance 1) between the bottom of the water seal and the floor, and 2) between the top of the water seal outlet and the bottom of the merchandiser. Do not over-rotate or gravity seal may be compromised. Always rotate trap bottom toward merchandiser support rail. It is the installing contractor's responsibility to consult local agencies for local code requirements.

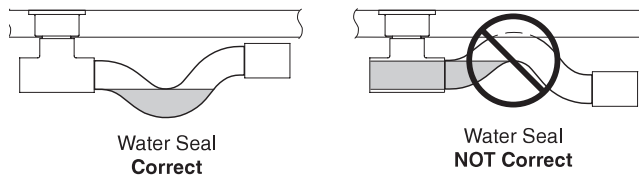

Flush Floor Drip Piping Example for Ultra Low Front Cases



Elbow is to be oriented toward rear of case. Install elbow to tee, place elbow on hub. Push elbow until it meets the liner.

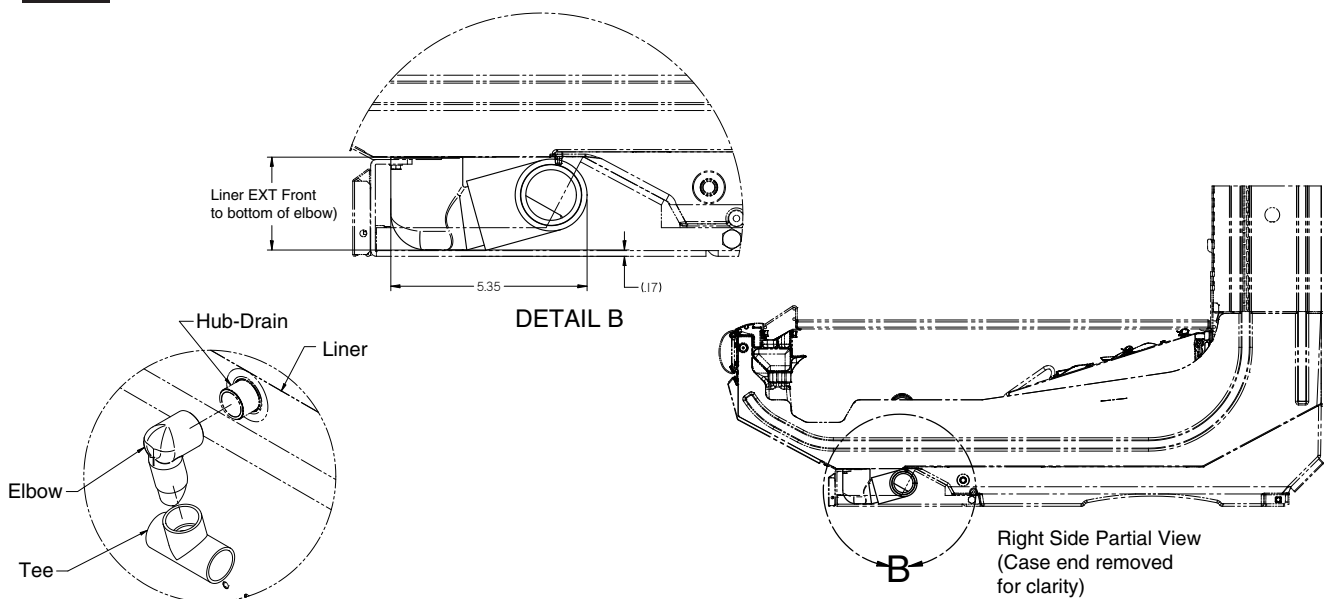

Insight® Single and Multideck Installation Information

Optional Waste Outlet Drip Piping Example for Ultra Low Front Cases

There is limited space underneath the case for piping ultra low front cases. If there is a waste outlet in the floor, use the ultra low front piping kit. This extends the splashguard forward. Follow the waste outlet location drawings on the following pages to install the drip piping in the correct location. This kit can also be used to pipe multiple cases to a single floor waste outlet/sink.

ITEM NUMBER	TITLE	QUANTITY	COMMENTS
1	ADAPTER-.750 SKT F X M 90 ELBOW	1	FACTORY INSTALLED
2	ELBOW-22.5 DEG .750 SOCKET SCH40	2	FACTORY INSTALLED
3	PIPE-.750 X 2 PVC SCH40	1	FACTORY INSTALLED
4	TEE-.750 SOCKET SCH 40 PVC	1	FACTORY INSTALLED
5	BUSHING-.750 X .5 SPIG X FNPT RDCR	1	FIELD INSTALLED
6	PLUG-.5 MNPT SCH 40 PVC	1	FIELD INSTALLED
7	ELBOW-90 DEG .750 SOCKET SCH40	3	FIELD INSTALLED
8	PIPE-.750 X 4.5 PVC SCH40	4	FIELD INSTALLED



Elbow trap is to be oriented toward rear of case. Install elbow to tee, place elbow on waste outlet of case. Push elbow trap until it meets the liner.



Insight® Single and Multideck Installation Information

Drain Location with Drain Extension Kit (Dimensions in Inches)

Standard Depth Models Ending in SU	4-foot	6-foot	8-foot	12-foot
(A) RH end of case to center of original waste outlet	24 1/8	24 1/8	24 1/8	72 1/4
(B) RH end of case to center of relocated waste outlet (with drain extension kit) *	13 3/4	13 3/4	13 3/4	61 7/8
(C) Back of case to center of original waste outlet	33 1/2	33 1/2	33 1/2	33 1/2
(D) Back of case to center of relocated waste outlet (with drain extension kit)	38 1/4	38 1/4	38 1/4	38 1/4
(E) Back of case to the back of the relocated splashguard (with drain extension)	41	41	41	41

* Drain Extension shown piped to the right but may be piped either direction

Drain Location with Drain Extension Kit (Dimensions in Inches)

Narrow Depth Models Ending in NU	4-foot	6-foot	8-foot	12-foot
(A) RH end of case to center of original waste outlet	24 1/8	24 1/8	24 1/8	72 1/4
(B) RH end of case to center of relocated waste outlet (with drain extension kit) *	13 3/4	13 3/4	13 3/4	61 7/8
(C) Back of case to center of original waste outlet	28 5/8	28 5/8	28 5/8	28 5/8
(D) Back of case to center of relocated waste outlet (with drain extension kit)	33 1/2	33 1/2	33 1/2	33 1/2
(E) Back of case to the back of the relocated splashguard (with drain extension)	35 1/8	35 1/8	35 1/8	35 1/8

* Drain Extension shown piped to the right but may be piped either direction



Insight® Single and Multideck Installation Information

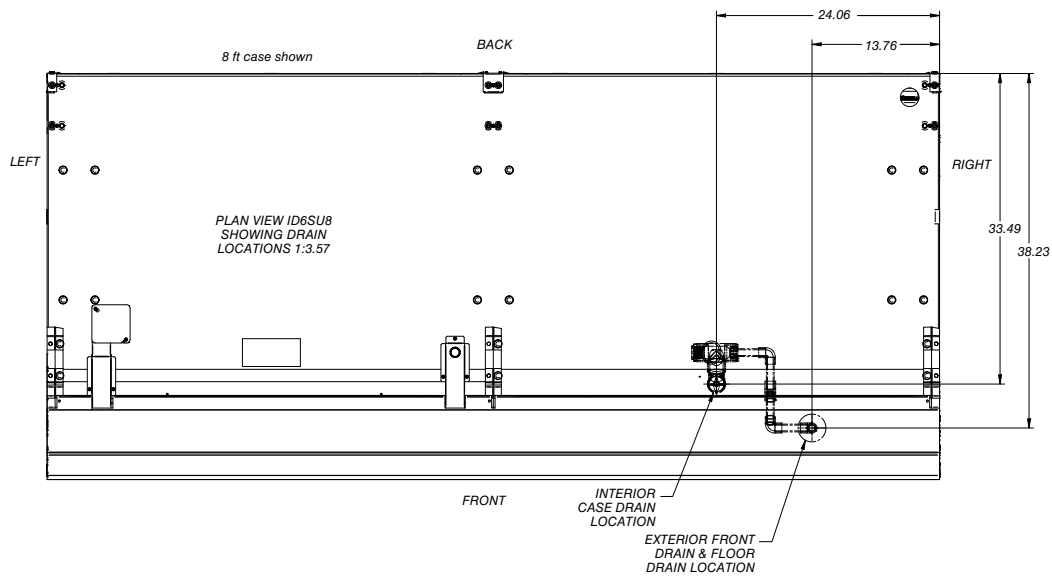

Insight® Single and Multideck

Installation Information

Electrical Information

Electrical field wiring connects at the terminal block located in the electrical enclosure on top of the case. Electrical requirements vary by case model. Refer to the technical data sheet for more information. Refer to the serial label located on the interior top panel of the cabinet to determine MCA and MOPD and to verify input voltage before making any electrical connections.

Merchandisers require dedicated electrical circuit(s) with ground. Consult equipment datasheet or equipment serial label for additional electrical specifications. Always use a dedicated circuit with the amperage stated on the equipment. Where components of multiple units are required to be wired to a single circuit, ensure that the load is distributed properly and proper disconnect locations are used. Do not overload the circuit.

It is necessary to allow for disconnection of the appliance from the supply power after installation. Disconnect power from the main disconnect before servicing the display cases.

If in doubt, consult an electrician.

Field Wiring

Components are wired as completely as possible at the factory with all work completed in accordance with the National Electrical Code (NEC). All deviations required by governing electric codes will be the responsibility of the installer. All wiring must be in compliance with governing electrical codes.

Field wiring must be sized for component amperes stamped on the serial label. Actual ampere draw may be less than specified. When multiple display cases are on the same defrost circuit, the defrost termination thermostats are wired in series. Field wiring from the refrigeration control panel to the merchandisers is required for defrost termination thermostats and for optional refrigeration thermostats.

WARNING: Always check the serial label for component amperes.

Based on the full load amps of the system, select the largest connectible wire size (based on no more than three wires in the wireway and 86° F (30° C) environment per NEC).

Electrical Connections

All wiring must be in compliance with NEC and local codes. All electrical connections are to be made at a terminal block, in the electrical wireway, or in a handy box. Terminal block is not for case-to-case connection. Any field-supplied connectors must be UL compliant for the intended application, including compliance in relation to potential hazards presented by flammable refrigerants, and follow all other applicable codes including NEC.

Identification of Wiring

Leads for all electrical circuits are identified by colored plastic bands. These bands correspond to the color code sticker (shown below) located inside the merchandiser wireway.

WIRING COLOR CODE	
Leads for all electrical circuits are identified by a colored plastic band: neutral wire for each circuit has either White insulation or a White plastic sleeve in addition to the color band.	
PINK.....REFRIG. THERMOSTAT LOW TEMP.	ORANGE OR
LIGHT BLUE...REFRIG. THERMOSTAT NORM TEMP.	TAN.....LIGHTS
DARK BLUE...DEFROST TERM. THERMOSTAT	MAROON.....RECEPTACLES
PURPLE.....CONDENSATE HEATERS	YELLOW*.....DEFROST HEATERS 120V
BROWN.....FAN MOTORS	RED*.....DEFROST HEATERS 208V
GREEN*.....GROUND	
*Either colored sleeve or colored insulation	
Electrician's note: Use copper conductor wire only.	
<ul style="list-style-type: none">• Case must be grounded.• These are marker colors wires may vary.	

Insight® Single and Multideck

Installation Information

Defrost Sequences

Insight merchandisers require defrost cycles for proper operation. Refer to the data sheets for application data. The Time Clock initiates defrost. The evaporator fans continue to circulate air across the evaporator coil, melting any frost build-up. If temperature termination is required, an applicable defrost sensor must be installed on the case.

Refrigeration Thermostat

Insight models do not use a defrost termination thermostat and are time terminated only.

Offtime Defrost



Insight® Single and Multideck

Installation Information

Control Sensor Location

Discharge air sensor is located in the case canopy by the honeycomb. An electrical box is shown at right for field installation of the sensor. (Field box may not be present if a sensor was not originally factory installed.)

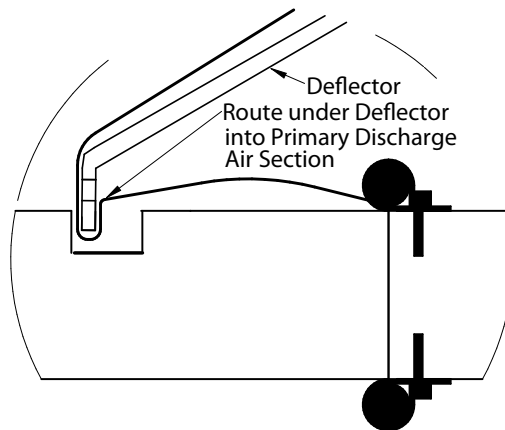

Insight® Single and Multideck Installation Information

Electrical Access for Sign-Ready & Flat-Front Fascias
See the images below to access the electrical connections.



Insight® Single and Multideck

Installation Information

Lighting

Insight display cases feature pre-installed LED canopy and shelf lighting. They can be turned on and off in a cold environment with no warm-up time and no negative impact on lamp life. The cases are equipped with 24-volt DC power supplies that power the LEDs. The power supplies are located in the canopy raceway. Power supplies are located in the field connection box for wedge cases. LEDs work well for dimming or on/off operation using an occupancy sensor (optional kits). Replace lights with like fixtures. Contact your Hussmann representative for more information.

⚠ WARNING

Hussmann does not recommend using spray hoses or misting systems due to risk of serious injury or death from electrical shock. Do not use spray hoses or misting systems on cases with shelf or rail lighting.

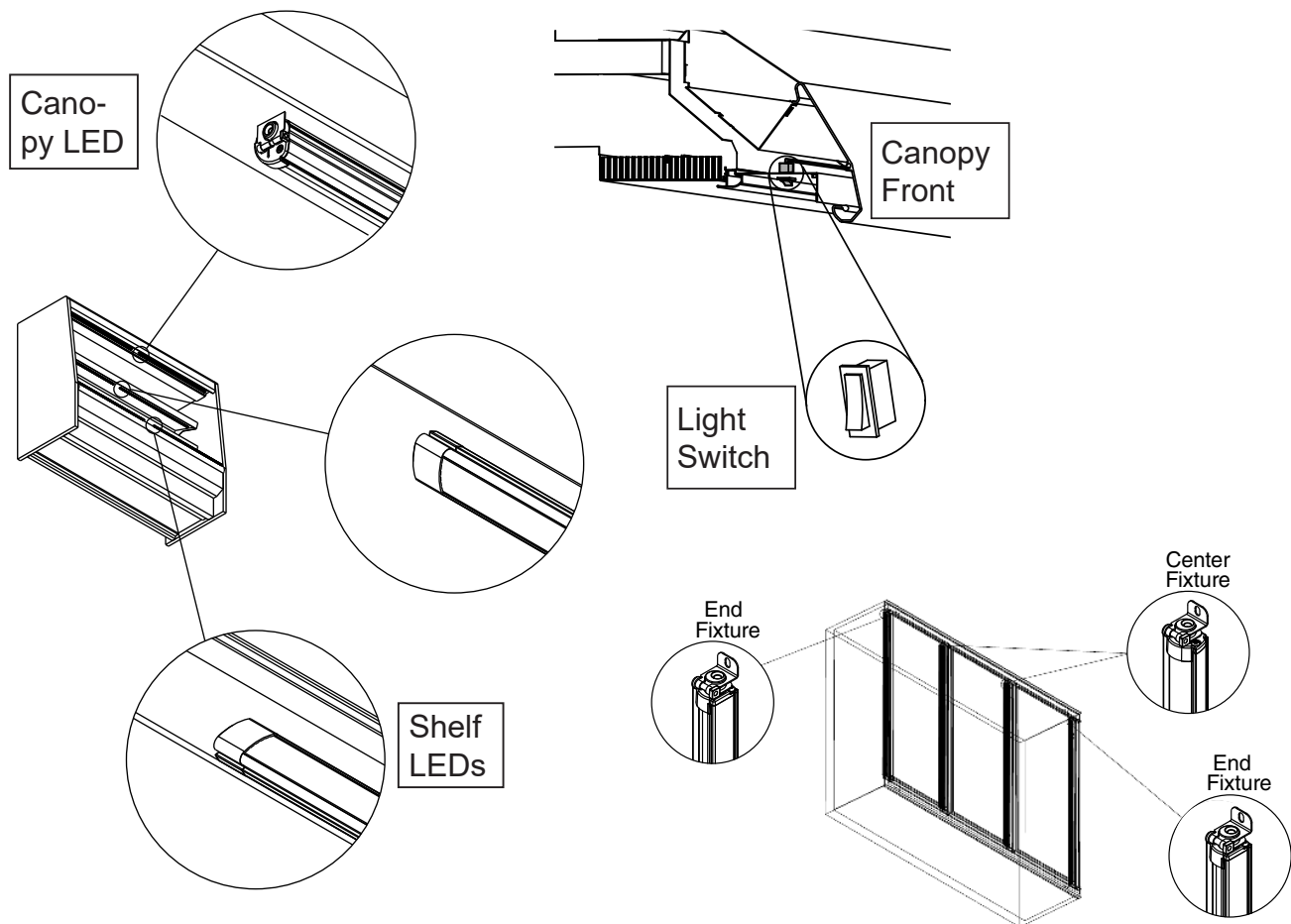

LED Mullion Light Bars

LED vertical mullion lights are an available lighting option for cases with EcoVision doors. Center fixtures illuminate the middle of the case, and the end fixtures illuminate the ends, or sides of the case.

These LEDs have different shaped lenses. They are not to be interchanged. Contact your Hussmann representative to order replacements.

The light bars are attached to the door mullions with mounting clips, and can be replaced similar to the canopy lights — just remove them from the mounting clips, and connect new wires at quick connect.

Insight® Single and Multideck

Installation Information

Refrigerant Charging Procedure

Only the specified refrigerant type can be used.

The triple evacuation method should be used to achieve a leak-free, dry system. For the first evacuation, the system should be pulled down to 1,000 microns. The second evacuation should be pulled to 500 microns. The final evacuation should be pulled down to at least 300 microns. A dry, leak-free system is when the system holds a vacuum of 300 microns for 24 hours with the vacuum pump de-energized and valved off. Between each evacuation, break the vacuum with dry nitrogen.

When connecting hoses between the refrigeration system, manifold gauges, and refrigerant cylinder, ensure that the connections are secure and there are no potential sources of ignition nearby. Ensure that contamination of different refrigerants does not occur when using charging equipment.

Use dedicated hoses to service the type of refrigeration system being serviced (e.g., R-454C equipment for an R-454C system). Hoses or lines should be as short as possible to minimize the amount of refrigerant contained in them.

Ensure that the refrigeration system is properly grounded prior to charging the system with refrigerant, to avoid the potential for static build-up.

In addition to conventional charging procedures, the following requirements shall be followed:

- a. Ensure that contamination of different refrigerants does not occur when using charging equipment. Hoses or lines shall be as short as possible to minimize the amount of refrigerant contained in them.
- b. Cylinders shall be kept in an appropriate position according to the instructions.
- c. Ensure that the REFRIGERATING SYSTEM is earthed prior to charging the system with refrigerant.
- d. Label the system when charging is complete (if not already).
- e. Extreme care shall be taken not to overfill the REFRIGERATING SYSTEM.

Prior to recharging the system, it shall be pressure-tested with the appropriate purging gas. The system shall be leak-tested on completion of charging but prior to commissioning. A follow up leak test shall be carried out prior to leaving the site.

Extreme care must be taken not to overfill the refrigeration system. After charging, carefully disconnect the hoses, attempting to minimize the quantity of refrigerant released. Further leak check the service ports, hoses, refrigerant tanks. Original service port washer and cap must be reinstalled to prevent refrigerant leaks. Cap must be tightened to 12–14 in-lb (1.4–1.6 nm) torque.

Refrigerant Charge Label

After charging is complete, note the refrigerant type and charge amount using permanent marking on the refrigerant charge label affixed to the unit.

Refrigerant	Charge
R- _____	_____ lbs

Insight® Single and Multideck

Installation Information

Pumped Liquid R-744 (CO₂) Start-Up Checklist

1. When the system(s) are ready for commissioning. Visually check all components. Check pressure and vacuum sheets complete. See Report #1A and #1B later in the document.
2. Load and check the controller's program and verify all Inputs and Outputs.
3. Main power available. Check for three-phase at sub-board. Connections tight on board. Compressors isolated. Check all cabinets (fans) clear of rubbish and that all electrical grounds have continuity and electrical tests have been completed by electrician.
4. Turn on power and check operation of cabinet and room fans, lights trim, heaters, door heaters, defrost heaters, drain heaters and all isolating switches. Start crank case heaters to warm oil.
5. Check individual breakers / fuse to prove circuits of all safety switches on refrigeration system, (HP/LP, oil failure). Compressor and condenser overloads for correct operation and set points, oil heaters and oil levels. All valves fully open. See Report #2 later in the document.
6. Start primary side compressors individually and check for correct three phase power and current draw. Charge up primary system. Open hot gas bypass lines to impose a load on the primary system during initial startup. Shut off hot gas bypass lines after system is charged.
7. Charge R-744 (CO₂) vessel initially with VAPOR until pressure is above 100 PSIG (6.9 bar), then continue charging with liquid. Charge with liquid until high liquid level sensor in the receiver senses liquid.
Note: Only one liquid CO₂ Pump may run at any given time. Shut off either the supply or return ball valve to the pump that is not in use. Dual pump operation—alternating pumps is not recommended by the pump manufacturer.
8. Start the liquid CO₂ pump. Then commence branch cooling in a staged basis of one branch at a time taking care to ensure that the CO₂ vessel pressure does not rise above 400 PSIG (27.6 bar)—do not rush this initial start-up stage, and do not run the CO₂ system until the high side system is fully operational.
Note: Do not open all solenoid valves at once. Run high side plant and check (adjust if necessary) superheats and operation of interstage heat exchanger.
9. Check cabinet and room temp setting, including cut in and cut out operation. Confirm the operation of the CO₂ leak detectors and alarm system.
Note: CO₂ leak detectors are to be located in every cooler room, freezer room, food preparation area, plant room and the retail area (as required by code).
10. Check defrost (and current draw on elements) operation and safety termination for each individual branch.
11. Check oil temps / pressures and high pressure / low pressure, pressures, and settings.
12. Check and record running amperages of compressors and condensers. Check moisture indicator.
13. Check and record operational amperages of all electrical loads (i.e., fans, lights, anti-sweat heaters, defrost heaters, etc.)
14. Turn off plant and recheck all electrical terminals for tightness or signs of overheating.
15. Check alarm system operation and settings.
16. After 100 hours of running on the primary system change: drier cores, suction filter cores, lubricant, and replace oil filters / strainers on the secondary system change: liquid line and dryer cores
17. Note: Maintenance requires these drier cores be replaced whenever the system is opened or at a minimum of every six months.
18. Leak test system and re-check electrical terminals. Re-check cabinet and room temp settings; including cut in and cut out operation.
19. Full training and the onsite Instruction Manual are to be provided by the refrigeration contractor to the employer's key (nominated) onsite store staff prior to the store opening date. This must include detailed safety training with particular attention to CO₂.

Insight® Single and Multideck

Installation Information

Pumped Liquid R-744 (CO₂) Operation

Sequence of Operation

This section describes the general operation of the R-744 liquid recirculation secondary systems. These systems are designed to be used in conjunction with a centralized parallel compressor rack system. The R-744 liquid recirculation system regulates case temperatures by circulating carbon dioxide through a case evaporator as it absorbs heat. The returning carbon dioxide is cooled to a liquid by the primary refrigerant supplied from the rack. The carbon dioxide is then pumped back through the case evaporator.

When the secondary system control circuit is powered up (120 volts) the chiller controller is powered. This controller regulates superheat on the primary side and must be programmed before starting the refrigeration system.

Turn on the main on/off switch to energize the pump. One pump will be “ON,” and one pump will be “OFF” as a backup pump. The pump that is “ON” will now run continuously. The R-744 receiver pressure and temperature is controlled by stepping the primary rack compressor capacity.

The rack stages compressors on and off based on the input from R-744 receiver pressure transducer. The EEV controller will regulate the superheat on the primary refrigerant side.

Defrost is initiated when the rack controller sends a signal to de-energize a case solenoid valve. The solenoid valve closes, and after a specified time delay, electric heat is switched on. Once the defrost period has elapsed, the electric heat is switched off. After a second time delay, the solenoid valve is energized. The R-744 (CO₂) refrigerant then resumes flow through the case.

Commissioning Checklist: https://www.hussmann.com/ns/Supplemental_IO/GD_Pumped_Liquid_R-744_CO2_Commissioning_Checklist_M001264.pdf

CO₂ Temperature Control

The CO₂ temperature is controlled by using the CO₂ receiver pressure as the reference point for the primary side compressor capacity.

Read CO₂ Receiver Pressure Control

Pressure Rise

IF

CO₂ receiver pressure rises 2 PSIG (0.1 bar) above the saturation pressure for the selected CO₂ setpoint temperature,

THEN

Rack controller increases the primary-side compressor capacity until the set point temperature CO₂ saturation pressure is reached.

Pressure Drop

IF

CO₂ receiver pressure falls 2 PSIG (0.1 bar) below the saturation pressure for the selected CO₂ setpoint temperature,

THEN

Rack controller decreases the primary-side compressor capacity until the set point temperature

Insight® Single and Multideck

Installation Information

Shutdown Modes

Low Pump Differential Pressure (PSIG [bar])

The rack controller (e.g., Copeland E3) monitors the discharge and suction pressure across the CO₂ pump that is “ON” and calculates the differential pressure using a flex combiner.

There will be dual pumps operating in parallel. One pump will be “ON” running continuously, and one pump will be “OFF” as a backup. There is a switch on the control panel to switch between Pump 1 or Pump 2. The two pumps will have different sets of discharge and suction pressure transducers.

Operation when pressure is in range:

IF

the differential pressure (psi [bar]) across the pump is greater than 5 psi (0.3 bar) or less than 60 psi (4.1 bar),

THEN

Rack controller sends output to turn the pump ON.

Operation when pressure is out of range:

IF

the differential pressure (psi [bar]) across the pump drops below 5 psi (0.3 bar) for a period of 10 seconds,

OR

IF

the differential pressure (psi [bar]) across the pump rises above 60 psi (4.1 bar) for a period of 10 seconds,

THEN

Rack controller sends output to turn the pump OFF. Rack controller sends alarm to identify “LOW PUMP DIFFERENTIAL PRESSURE SHUT DOWN.” After a 2-minute time delay, Rack controller sends output to turn the pump ON.

Multiple Restart and Lockout Procedure

IF

2nd shutdown is within 15 minutes,

THEN

re-start after time delay of 2 minutes.

IF

3rd shutdown is within 15 minutes,

THEN

re-start after time delay of 2 minutes.

IF

4th shutdown within 15 minutes,

THEN

lockout and require an inspection by service technician.

Insight® Single and Multideck

Installation Information

Thermostatic Expansion Valve (TXV) Adjustment

Each four-foot section has its own evaporator coil and pre-set adjustable thermostatic expansion valve (TEV). Evaporator super heat must be checked on all cases during startup. The TEV has been factory set to provide the recommended performance settings as specified on merchandiser data sheets. Only a certified technician should adjust these valves. Always be sure to replace the TEV cap, missing TEV cap could result in refrigerant loss



Safety Shut-Off Valves (A2L only)

- Safety shut off valves are factory-installed on each case. Do not bypass safety shut off valves.
- Safety shut-off valves shall not block in liquid refrigerant unless adequate relief is provided to the refrigerant system low pressure side.
- Safety shut-off valves are located in such a way such that leaks upstream of the safety shut-off valve shall not enter the internal volume of the partial unit and in a space with a room volume large enough so that the maximum refrigerant charge complies to the limit for releasable charge.
- Safety shut-off valves are positioned to enable access for maintenance by an authorized person.
- Top-piped (tall) cases: The safety shut-off solenoid valve is located in the A2L isolation valve enclosure at the rear top of the case, on the right side near the refrigerant piping (top piping) ingress.
- All other Insight cases: The safety shut-off solenoid valve is located in A2L isolation valve enclosure behind the splashguard panel underneath the case on the right side. See detailed image of the shut-off solenoid valve on the next page.

Safety shut-off valve location for Insight (tall) cases with top piping



Insight® Single and Multideck Installation Information

Safety shut-off valve location for Insight (short) cases.



Pumped Liquid R-744 (CO₂) Case Inlet Solenoid Valve

The 120 VAC case inlet solenoid valve is normally closed and must receive a signal from the rack or case controller to provide temperature control. The solenoid valve must shut off (de-energize) during defrost and when case discharge air temperature is satisfied. Settings are provided on the CO₂ application data sheets for each specific case model.

Differential of the controller must be set to 2° F (1.1° C) or less to avoid large fluctuations in discharge air temperature. A swing of as much as 5° F (2.8° C) total (+/-2.5° F [1.4° C]) will not affect product temperatures.

Liquid line solenoid lead wires are terminated in the raceway and marked with an identification tag or connected to a factory installed case controller.

Insight® Single and Multideck Installation Information

Panel, Bumper, and Guard Installation

Panel Alignment

Fascia Top Cap Alignment

Applies to (IP4/IM5/ID5/ID6/IC6)



Fascia Top Cap can slide toward the center of (multideck) case lineups to eliminate gaps.

1. Pull fascia top cap to uncover fixing screws.
2. Loosen the screws of fascia top cap.
3. Move fascia top cap towards the lineup center. Tighten the screws after finishing the alignment.
4. Snap fascia top cap to closed position.
5. Install fascia trim (optional) between joints and at ends. Hook at bottom first, then snap top into place.

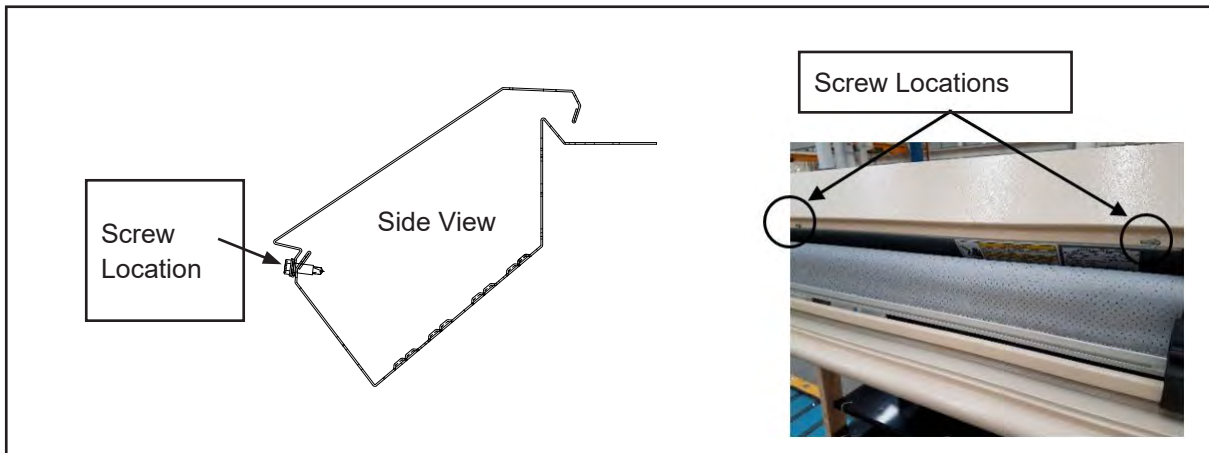

Insight® Single and Multideck Installation Information

Fascia Panel Alignment

Applies to (IP4/IM5/ID5/ID6/IC6)

Fascia panels can slide toward the center of (multideck) case lineups to eliminate gaps.

1. Slide fascia panels toward lineup center as shown in the illustration below.
2. Place optional fascia trim between fascia joints between end panel and fascia and between case lineup joints. Install tape to joint first, then attach bottom and top fascia trim.

Top Cap
Fascia Panel

Fascia
Panel



Standard Faceted Fascia shown

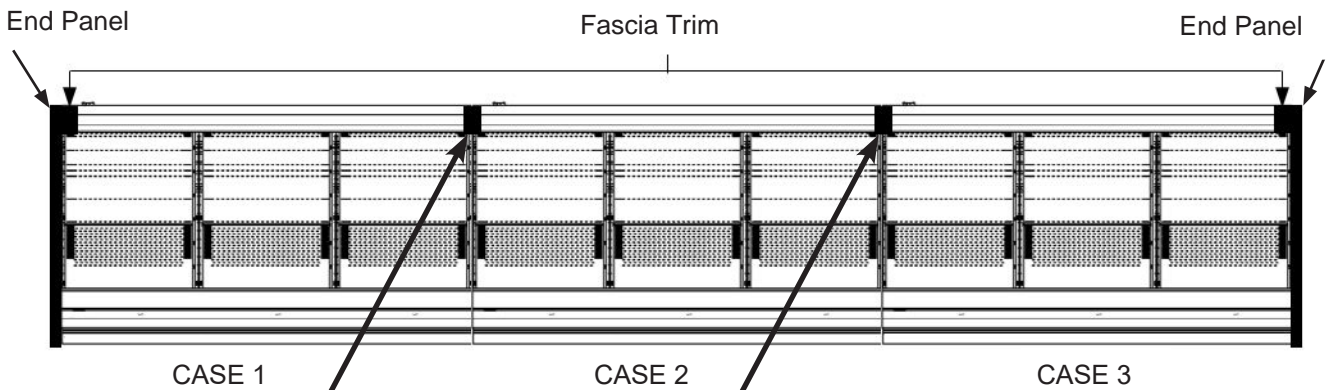

Optional Fascia Trim can be applied to case-to-case Fascia Joints

Insight® Single and Multideck Installation Information

Fascia Panel Alignment

Applies to (IC2 / IC2X / IC3)

Fascia panel can slide toward the center of case lineups to eliminate gaps.

Fascia trim is then needed at the end of either side of the lineups to eliminate gaps at the ends.

1. Loosen the fascia screws located at the inner bottom of fascia.
2. Slide fascias toward the lineup center to eliminate gaps between fascias and tighten the screws.
3. Place optional fascia trim between fascia joints between end panel and fascia and between case lineup joints. Install tape to joint first, then attach bottom and top fascia trim.

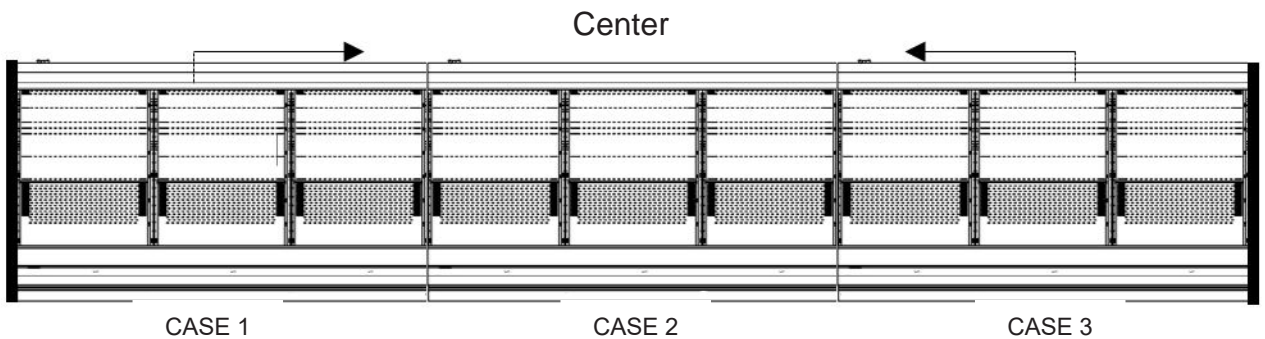

Insight® Single and Multideck Installation Information

Front Panel Alignment

Front Panels can slide toward the center of (multideck) case lineups to eliminate gaps.

1. Loosen the front panel screws located at the bottom of Front Panel.
2. Slide front panel towards the lineup center to eliminate gaps between front panels. Tighten the screws after finishing the alignment.
3. Place optional front panel trim at case lineup joint. Install tape to joint first, then attach front panel trim.



NOTE Remove Front Skid Brace before aligning Front Panels. Align Panels before installing the Splashguard Front and Bumpers.



Insight® Single and Multideck

Installation Information

Installing Splashguards

(Retainers and Panels)

Splashguards are shipped inside each merchandiser, 4 brackets for 12 ft case, 3 for 6 ft, etc. After merchandisers have been leveled and joined, and all drip piping, electrical and refrigeration work has been completed, install the splashguard.

To Install Splashguards:

1. Check to be sure that all splashguard brackets are level with the floor.
2. Loosely attach the lower splashguard retainer bracket using # 8 SM screws (1).
3. Install close-off panel as shown in (2 & 3). Slide splashguard close-off panel between the bracket and lower front support.
4. Raise the splashguard close-off panel to where the top fits into bend on the lower color panel, then tighten the splashguard brackets.
5. Fit the lower splashguard into the slots on the lower splashguard retainer. Lower splashguard snaps into place (4).



To install Optional cove trim to the splashguard:

1. Remove all dirt, wax and grease from the area of the splashguard where adhesion will be necessary to ensure a secure installation.
2. Apply a good contact cement to the cove trim and allow proper drying time according to the directions supplied with the cement.
3. Install the trim to the splashguard so that it is lying flush with the floor. Do not seal the trim to the floor.
4. If required by local health codes the Cove Trim may be sealed to the floor, using a silicone type sealer. Sealant must be removed and replaced when servicing.

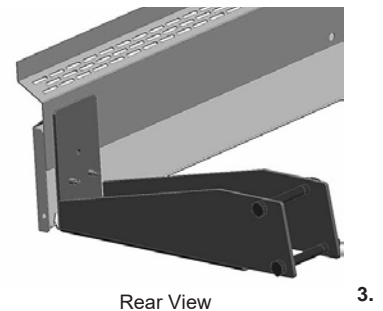

Splashguard Alignment to eliminate gaps in cases Line-Up

1. Slide Splashguard towards line-up center to eliminate Splashguards gaps.

(See next page for installing fan splashguards).

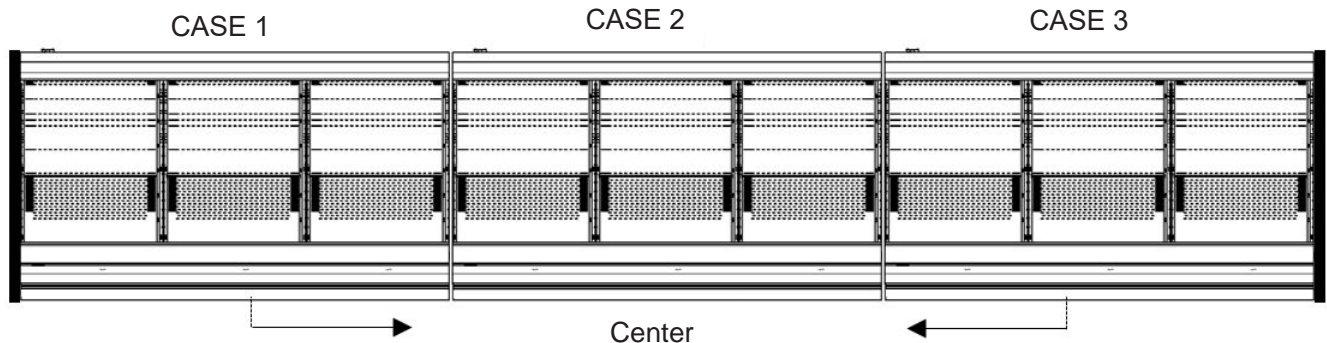

Insight® Single and Multideck

Installation Information

Installing Splashguard Fans (A2L only)

(Retainers and Panels)

Splashguard fans are shipped with single-deck and multi-deck door cases that utilize A2L refrigerants. Splashguard fans must be installed in order for the case to operate. These fans are always off during normal operation, and turn on if an A2L leak is detected.

To Install Splashguard Fan:

1. Check to be sure that all splashguard brackets are level with the floor. Refer to previous page for additional exploded view pictures.
2. Loosely attach the lower splashguard retainer bracket using # 8 SM screws (1).
3. Install close-off panel (images 2 and 3 on previous page). Slide splashguard close-off panel between the bracket and lower front support.
4. Raise the splashguard close-off panel to where the top fits into bend on the lower color panel, then tighten the splashguard brackets.
5. Install splashguard fan assembly. Connect the fan harness to the receptacle harness under the case. Slide splashguard fan assembly over the retainer.
6. Fit the splashguard fan assembly into the slots on the lower splashguard retainer. Splashguard fan snaps into place.
7. Confirm the splashguard fan assembly and harness is firmly attached, unobstructed, and operational.



Insight® Single and Multideck Installation Information

Installing End Splashguards

(Standard Case)

1. End splashguard must be slid in from the front, so that it fits behind the end panel. Attach end splashguard brackets to base at locations shown in the illustrations below.
2. Align forward edge of splashguard end panel to the inside of front splashguard. Fasten end splashguard to bracket with screws.
3. If end assembly bolt is loosened & seal broken when installing end splashguard, apply caulk to seal end assembly to inside of case.



End Splashguard Panel fits to the inside of End Assembly.



IMPORTANT

Install end splashguard before installing front splashguards.



Insight® Single and Multideck Installation Information

Installing End Splashguards

(Detail below for cases with elevated case heights.)

1. End splashguard must be slid in from the front, so that it fits behind the end panel. Attach end splashguard brackets (2) to base at locations shown in the illustrations below.
2. Align forward edge of splashguard end panel to the inside of front splashguard. Fasten end splashguard to bracket with screws.



Insight® Single and Multideck Installation Information

Installing Bumpers

1. Bumpers are packed out with the case and snap onto the bumper retainer. Gaskets are factory installed in the bumper retainers to provide support for the bumpers. Do not remove the gaskets.
2. Bumper joint inserts are provided with the case to disguise joints for a lineup of cases.
3. Start at the left end of the lineup. Install 3ft starter bumper first. Refer to bumper side view illustration to ensure the bumper is orientated correctly. Place top of bumper over bumper retainer, then snap bottom of bumper into place at bottom of retainer. Position internal joint trim between the starter bumper and full-length bumper.
4. Continue installing bumper(s) until the lineup is complete. The last piece of bumper will need to be cut so that it is flush with the right end cap. Use a fine tooth saw to cut the bumper vertically at a 90° angle.
5. Ensure joint trim is positioned behind bumper at all joints to close any gaps in the lineup. Remove protective film from bumper once installation is complete.



NOTE Bumpers come in two styles: Ellipse and Faceted.

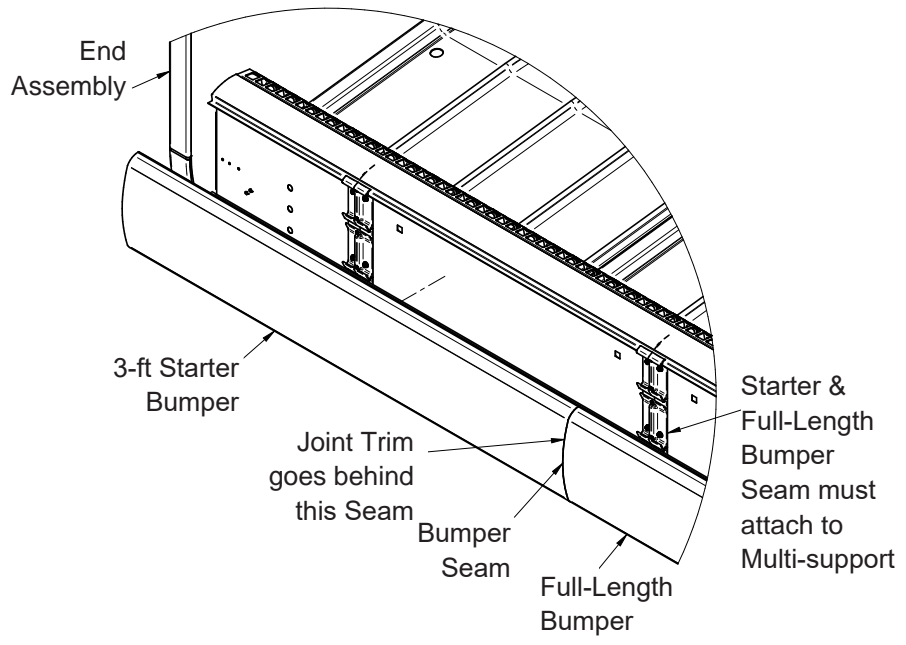

Insight® Single and Multideck

Installation Information

Shelf Installation

After the cabinet is leveled, the shelves may be installed. Various shelf depths are offered. Heights are adjustable in one-inch increments. All shelves and the lower deck are intended to display product.

To install shelves place the rear of the bracket in the desired slot. Raise the front of the brackets towards the rear of the cabinet. Once the ends are in the slot, rotate the bracket forward, locking it in place.

Procedure for Installing Lighted Shelves

Follow these instructions to ensure good contact between male and female connectors.

1. Remove any products from the case and place in cooler. Shut off power to the merchandiser.
2. Turn off Canopy Light Switch. Remove all packed shelves.



3. Engage each power socket cap, and ensure that each cap is fully seated before cleaning. Ensure the proper seating of the cap at all times when the plug is not engaged.
4. Clean the merchandiser as described in the Care and Cleaning paragraphs of Section 5 — Maintenance. Keep liquid out of sockets. (Allow merchandiser shelves to dry before turning on shelf power.)
5. Verify power to the merchandiser is turned ON. Verify that the merchandiser light switch is turned OFF. The switch is located in the canopy, on the left side.
6. Refer to the illustration at the top of the next page. Note that other models will have fewer rows of shelves. Starting from the left-hand (where applicable) bottom section, choose the location for the first shelf, X-1.
7. Secure the shelf in the slotted upright. Make certain that the shelf is level and that ends are in the same slot on the left and right upright. Markings on the shelf uprights indicate the proper shelf notch for each shelf location. It is important that shelf brackets be properly seated in the slotted upright.
8. Working from left to right (where applicable), install the next shelf, X-2, to the right of the first shelf you installed. Always work from left to right and from the bottom up in each 90° wedge case.
9. After each shelf on the bottom row is in position, be sure to remove the cap and insert the shelf connector. Push firmly.
10. Turn ON the wedge case light switch after the entire bottom row has been installed. The shelf lights should light.

If an LED shelf light does not operate:

- a. Turn off light switch.
- b. Remove and firmly re-insert each shelf plug.
- c. Turn on light switch.



Insight® Single and Multideck

Installation Information

If lights do not operate after checking the items listed above, contact the installation contractor.

11. Using the row of shelves just installed as support, set the next shelf, X-3, in the desired location. Remove the cap and insert the shelf plug. Continue working left to right installing shelf X-4.

Note: Since the location for the remaining shelves, X-4 to X-10, may be directly over the rear wall receptacle, the shelf should be plugged in before engaging brackets in the uprights. The lower shelf will support the weight of the next shelf until it is plugged in. After installing each shelf, verify that its plug is properly connected to its rear wall receptacle. Continue working row by row, bottom up, left to right.

If a shelf is plugged in and the lamp does not work, verify the case light switch is ON.

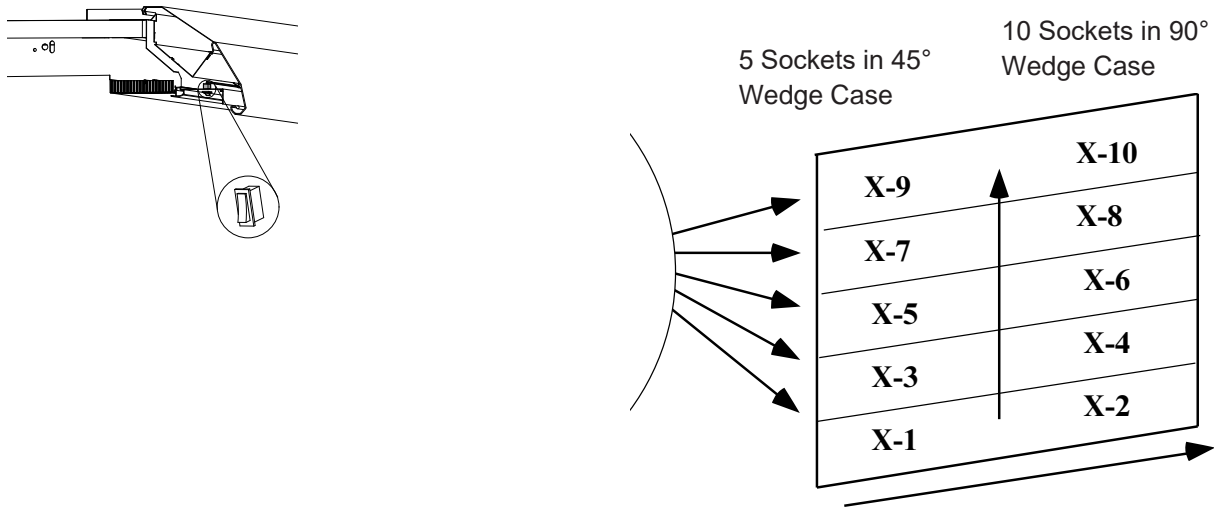

Always work Left to Right, and Bottom to Top

Shelf LED clips must be first inserted into the front lip underneath the shelf as shown at left. Next the retaining clip is “snapped on” to the rear of the LED clip.

Shelf LED Clip Installation



Insight® Single and Multideck Installation Information

Use caution when installing Product Stops. Product stop legs must be inserted at an angle. When product leg goes through the shelf, it must rest behind the LED shelf light as shown below.

Product Stop Installation



Insight® Single and Multideck

Installation Information

Load Limits

Shelves are individually mounted in 1 in. (25 mm) increments and have two-, three-, or four-position brackets, permitting shelves to be placed in a flat or down-tilt position (see illustration). Front product stops are recommended when shelves are placed in the down-tilt position. Case performance will be degraded if peg shelves are used without baffles. Unauthorized specialty shelving may cause poor merchandiser performance. Consult your Hussmann representative to ensure optimum performance of Hussmann equipment.

Exceeding this load can cause damage to the shelves, case, damage to store products, and potentially create a hazardous condition for customers and store personnel. Product must be within designated load limit to ensure proper refrigeration and air curtain performance. Product shelves should be loaded so that the product does not extend over the front edge of the shelf. Product loaded over the edge will interfere with air circulation in the cabinet. It is also desirable to leave a small space between the rear interior wall and the product on the shelves, to allow air to enter the cabinet interior through the perforations in the rear wall.

Air discharge and return flues must remain open and free of obstruction at all times to provide proper refrigeration and air curtain performance. Do not allow product, packages, signs, etc. to block these grilles. Do not use non-approved shelving, baskets, display racks, or any accessory that could hamper air curtain performance. For displace cases with doors, do not prop doors open while stocking, and keep the doors closed as much as possible to prevent coil frosting and high merchandiser temperature. Shelves are designed to support the maximum weight load limits as indicated in this table.

Shelf Depth	Max. Load Limit (at 0° tilt)
14 in. (356 mm) x 48 in. (1,219 mm)	125 lb (77 kg)
16 in. (406 mm) x 48 in. (1,219 mm)	200 lb (91 kg)
18 in. (457 mm) x 48 in. (1,219 mm)	200 lb (91 kg)
20 in. (508 mm) x 48 in. (1,219 mm)	250 lb (113 kg)
22 in. (559 mm) x 48 in. (1,219 mm)	250 lb (113 kg)
24 in. (610 mm) x 48 in. (1,219 mm)	250 lb (113 kg)
14 in. (356 mm) x 36 in. (1,219 mm)	125 lb (77 kg)
16 in. (406 mm) x 36 in. (1,219 mm)	200 lb (91 kg)
18 in. (457 mm) x 36 in. (1,219 mm)	200 lb (91 kg)
20 in. (508 mm) x 36 in. (1,219 mm)	250 lb (113 kg)
22 in. (559 mm) x 36 in. (1,219 mm)	250 lb (113 kg)
24 in. (610 mm) x 36 in. (1,219 mm)	250 lb (113 kg)



Product Stocking

In addition to the prior recommendations for spacing, product should always be maintained at proper temperature. This means the temperature of the product must be controlled from the time the product is received through storage, preparation, and display to maximize the life of the product.

Product should not be placed inside the merchandisers until merchandisers are at proper operating temperature. Allow merchandiser 24 hours to operate before loading product. Proper rotation of product during stocking is necessary to prevent product loss. Always bring the oldest product to the front and set the newest to the back.

- Air discharge and return flues must remain open and free of obstruction at all times to provide proper refrigeration and air curtain performance. Do not allow product, packages, signs, etc. to block these grilles.
- Do not prop doors open while stocking. And keep the doors closed as much as possible to prevent coil frosting and high merchandiser temperature.
- Hussmann recommends solid shelves for ice cream.

Insight® Single and Multideck Installation Information

⚠ CAUTION

Case ventilation openings must be clear of any obstructions. Do not damage the refrigerant circuit.

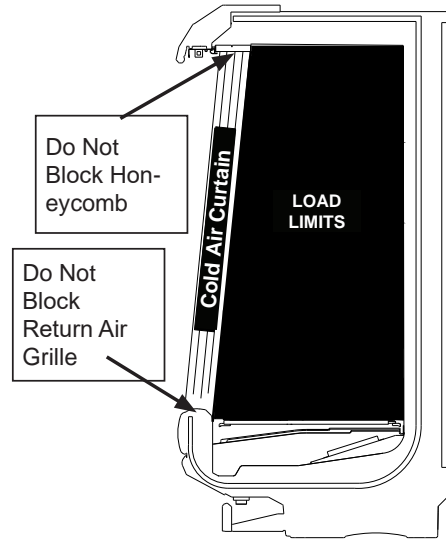

Installing CaseShieldPTM(s) (Optional)

The CaseShieldPTM is installed on the front edge of shelves as a replacement to existing price tag molding (PTM). It acts as a guide for the air from the discharge to the return air grille to reduce turbulence and save energy.

To install the CaseShieldPTM:

Slide the CaseShieldPTM onto the shelf as shown in B below.

Note: For use only with straight shelves. Do not apply CaseShieldPTM(s) to angled shelves.

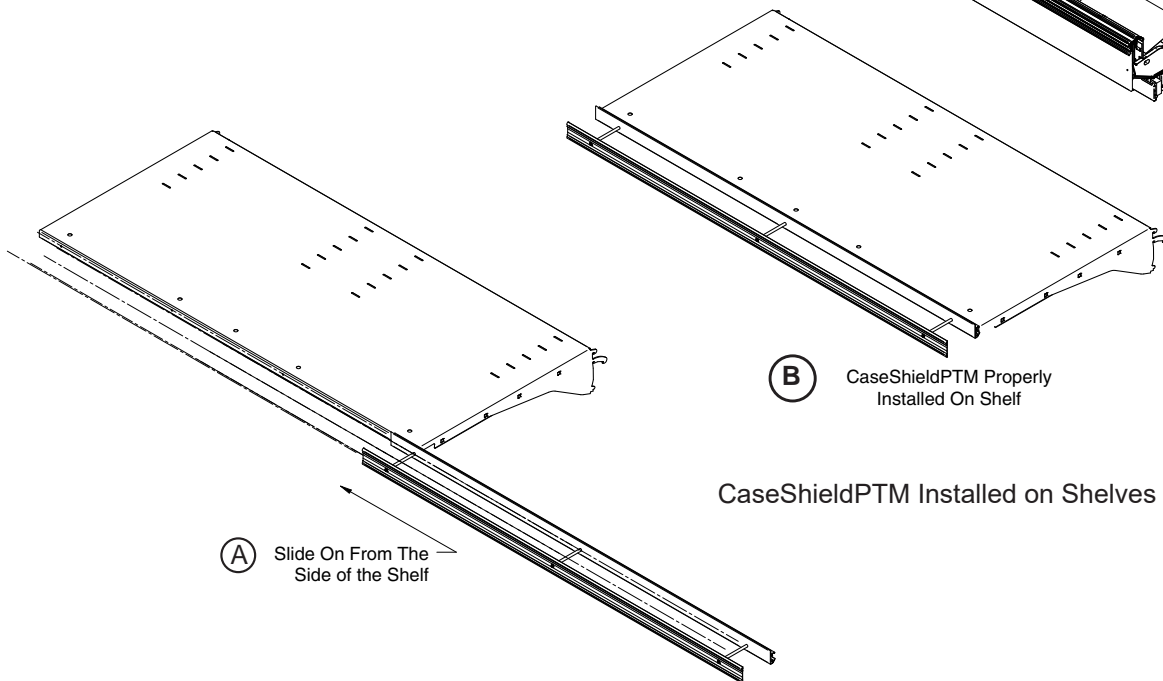

(A) Slide On From The Side of the Shelf

(B) CaseShieldPTM Properly Installed On Shelf

CaseShieldPTM Installed on Shelves

Insight® Single and Multideck

Maintenance and Service

WARNING

READ ALL WARNINGS AND PROCEDURES IN THIS MANUAL AND ON THE EQUIPMENT BEFORE SERVICING OR PERFORMING MAINTENANCE ON THIS EQUIPMENT.

FAILURE TO ABIDE BY THESE WARNINGS COULD RESULT IN AN EXPLOSION, DEATH, INJURY, AND PROPERTY DAMAGE.

Checks and Repairs for A2L Equipment

Prior to beginning work on systems containing flammable refrigerants, safety checks are necessary to ensure that the risk of ignition is minimized.

- Work shall be undertaken under a controlled procedure, as documented below, to minimize the risk of a flammable gas or vapor being present while work is being performed.
- Prior to performing any service work, make sure all tools and equipment have been certified for use with flammable refrigerants.
- All maintenance staff and others working in the local area shall be instructed on the nature of work being carried out. Work in confined spaces shall be avoided.
- The area shall be checked with an appropriate refrigerant detector prior to and during work, to ensure the technician is aware of potentially toxic or flammable atmospheres. Ensure that the leak detection equipment being used is suitable for use with all applicable refrigerants, i.e., non-sparking, adequately sealed, or intrinsically safe.
- If any hot work is to be conducted on the refrigerating equipment or any associated parts, appropriate fire extinguishing equipment shall be available on hand. A dry chemical or CO₂ fire extinguisher should be adjacent to the charging area.
- No person carrying out work in relation to a refrigerating system which involves exposing any pipe work shall use any sources of ignition in such a manner that it may lead to the risk of fire or explosion. All possible ignition sources, including cigarette smoking, should be kept sufficiently far away from the site of installation, repairing, removing and disposal, during which refrigerant can possibly be released to the surrounding space. Prior to work taking place, the area around the equipment shall be surveyed to make sure that there are no flammable hazards or ignition risks. "No Smoking" signs shall be displayed.
- Ensure that the area is in the open or that it is adequately ventilated before breaking into the system or conducting any hot work. A degree of ventilation shall continue during the period that the work is carried out. The ventilation should safely disperse any released refrigerant and preferably expel it externally into the atmosphere.
- The following checks shall be applied to installations using flammable refrigerants:
 - i. The actual refrigerant charge is in accordance with the room size within which the refrigerant containing parts are installed.
 - ii. The ventilation machinery and outlets are operating adequately and are not obstructed.
 - iii. If an indirect refrigerating circuit is being used, the secondary circuit shall be checked for the presence of refrigerant.
 - iv. Marking to the equipment continues to be visible and legible. Markings and signs that are illegible shall be corrected.
 - v. Refrigerating pipe or components are installed in a position where they are unlikely to be exposed to any substance which may corrode refrigerant containing components, unless the components are constructed of material which are inherently resistant to being corroded or are suitably protected against being so corroded.

Insight® Single and Multideck

Maintenance and Service

- During repairs to sealed components, all electrical supplies shall be disconnected from the equipment being worked upon prior to any removal of sealed covers, etc. If it is absolutely necessary to have an electrical supply to equipment during servicing, then a permanently operating form of leak detection shall be located at the most critical point to warn of a potentially hazardous situation. Particular attention shall be paid to the following to ensure that by working on electrical components, the casing is not altered in such a way that the level of protection is affected. This shall include damage to cables, excessive number of connections, terminals not made to the original specification, damage to seals, incorrect fitting of glands, etc.
 - i. Ensure that the apparatus is mounted securely.
 - ii. Ensure that seals or sealing materials have not degraded to the point that they no longer serve the purpose of preventing the ingress of flammable atmospheres. Replacement parts shall be in accordance with the manufacturer's specifications.
- Intrinsically safe components are the only types that can be worked on while live in the presence of a flammable atmosphere. The test apparatus shall be at the correct rating. Replace components only with parts specified by the manufacturer. Other parts can result in the ignition of refrigerant in the atmosphere from a leak.
- Any vacuum used for cleaning coils should be approved for flammable refrigerants.

Checks and Repairs for R-744 (CO₂) Equipped Equipment

- Replacement parts must be compatible with the specific equipment's maximum design pressure as shown on the equipment labeling. For example, if the equipment has been designed to meet 1,305 psig (90 bar) maximum design pressure then any replacement part must be 1,305 psig (90 bar) compatible.

Checks and Repairs for All Equipment

- Repair and maintenance to electrical components shall include initial safety checks and component inspection procedures. If a fault exists that could compromise safety, then no electrical supply shall be connected to the circuit until it is satisfactorily dealt with. If the fault cannot be corrected immediately but it is necessary to continue operation, an adequate temporary solution shall be used. This shall be reported to the owner of the equipment, so all parties are advised. Initial safety checks shall include:
 - i. Ensure that capacitors are discharged—this shall be done in a safe manner to avoid the possibility of sparking.
 - ii. Ensure that no live electrical components and wiring are exposed while charging, recovering, or purging the system.
 - iii. Ensure that there is continuity of earth bonding.
- Do not apply any permanent inductive or capacitance loads to the circuit without ensuring that this will not exceed the permissible voltage and current permitted for the equipment in use.
- LOCK OUT / TAG OUT — To avoid serious injury or death from electrical shock, always disconnect the electrical power at the main disconnect when servicing or replacing any electrical component. This includes, but is not limited to, such items as doors, lights, fans, heaters, and thermostats.
- Check that cabling will not be subject to wear, corrosion, excessive pressure, vibration, sharp edges, or any other adverse environmental effects. The check shall also take into account the effects of aging or continual vibration from sources such as compressors or fans.
- Refrigerating pipe or components are installed in a position where they are unlikely to be exposed to any substance which may corrode refrigerant containing components, unless the components are constructed of materials which are inherently resistant to being corroded or are suitably protected against being so corroded.
- To reduce the risk of fire, electrical shock or injury when cleaning this merchandiser:
 - Unplug the merchandiser before cleaning.
 - Keep all liquids away from electrical and electronic components.

Insight® Single and Multideck

Maintenance and Service

Care and Cleaning

Long life and satisfactory performance of any equipment is dependent upon the care it receives. To ensure long life, proper sanitation and minimum maintenance costs, these merchandisers should be thoroughly cleaned, all debris removed and the interiors washed down as part of a regular store sanitation schedule.

Fan Plenum

To facilitate cleaning, the fan plenum is hinged. After cleaning be sure the plenum is properly lowered into position or product loss will result due to improper refrigeration. Fan motor harness plug must be securely connected. Do not disconnect fan motor harness plug for cleaning or maintenance procedures.

To lift the fan plenum:

1. Gently bend the bottom of the hinge pin arm away from the plenum to release the retainer from the coil support.
2. Rotate the hinge pin 180° so that the arm is pointed upwards.
3. Slide the hinge pin out and away from the plenum.

The plenum can also be removed, but this is not necessary for routine cleaning.



Lift up Fan Plenum. Use chain to hook up fan plenum to facilitate cleaning.

1. Flip the arm up and pull arm out to release the plenum.



Removable Return Air Grilles

The return air grilles may be removed to facilitate cleaning. Lift a four foot section up and out as shown below.

⚠️WARNING

All display case cleaning and maintenance procedures should be done with the power disconnected at the breaker.

Do not allow cleaning agent or cloth to contact food product.

Product will be degraded and may spoil if allowed to sit in a non-refrigerated area.

All products in the case should be removed and stored in a cooler at the appropriate temperature before cleaning the interior of the case.

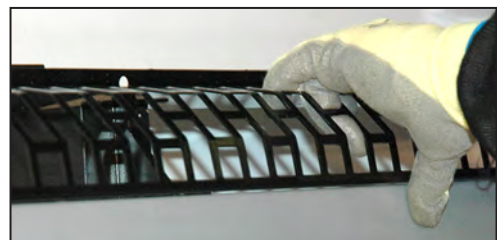

Insight® Single and Multideck Maintenance and Service

Identification of Display Case Parts

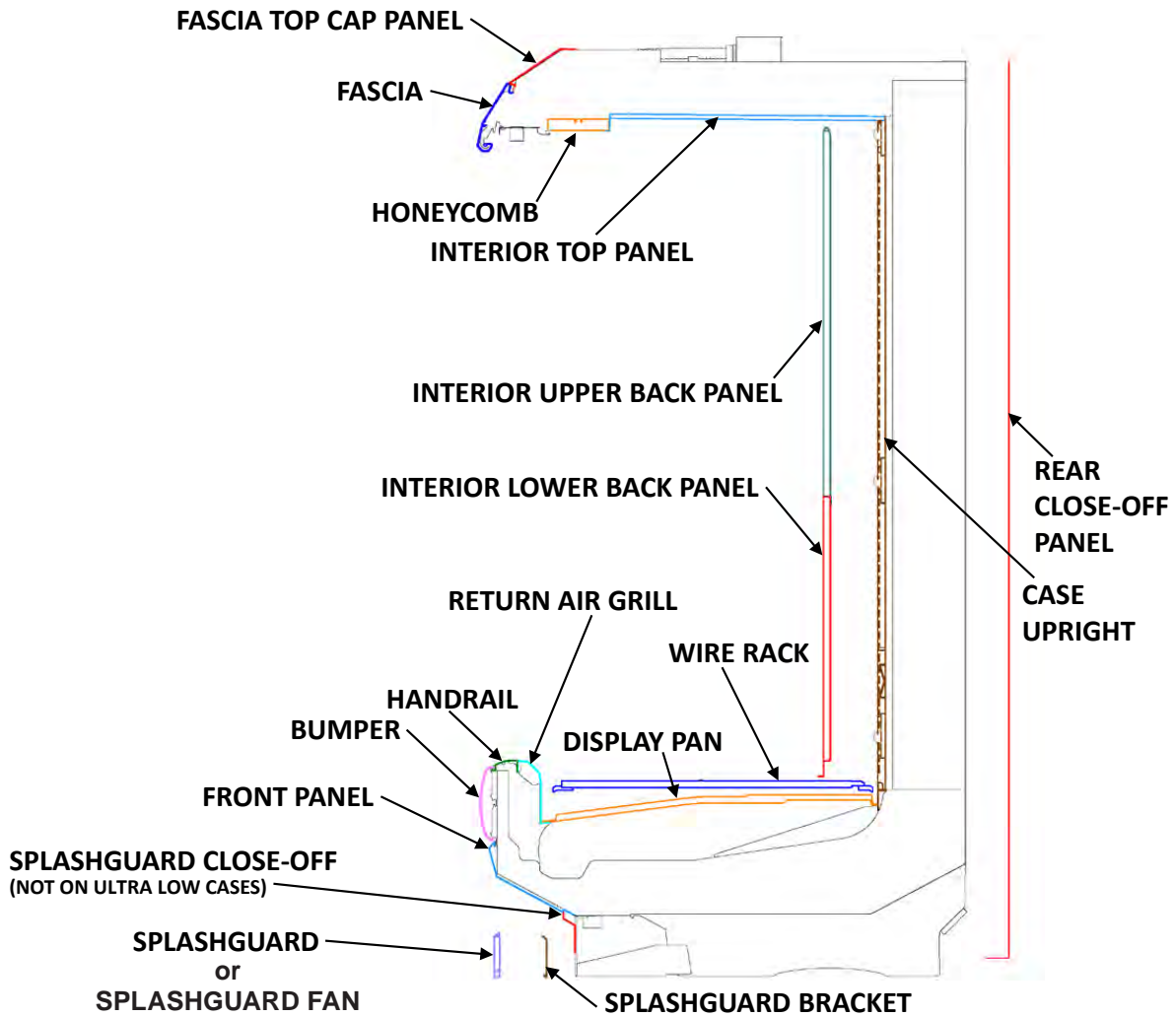

Insight® Single and Multideck

Maintenance and Service

Fascia Panels

The exterior of the fascia panels should be cleaned with a mild detergent and warm water. Do not use ammonia-based products to clean optional acrylic panels. Never use abrasive cleansers or scouring pads.

Exterior Surfaces

The exterior surfaces must be cleaned with a mild detergent and warm water to protect and maintain their attractive finish.

Never use abrasive cleaners or scouring pads.

Interior Surfaces

The interior surfaces may be cleaned with most domestic detergents, ammonia based cleaners and sanitizing solutions will not harm the surface. Always read and follow the manufacturer's instructions when using any cleaning product.

Inspect all LED connections and plug/ receptacles for signs of arcing. Replace any component that shows signs of arcing. Make sure all unused receptacles have close-off covers securely attached.

Do Not:

- Abrasive cleansers and scouring pads, as these will mar the finish.
- Coarse paper towels on coated glass.
- Ammonia-based cleaners on acrylic parts.
- Do not spray water from a hose directly on the canopy lights or fans.
- Solvent, oil or acidic based cleaners on any interior surfaces.
- A pressure nozzle on canopy lights, shelf lights or any other electrical connection.
- Do not use water pressure beyond what is supplied from the potable water system and spray nozzle (ie Do not use a pressure washer).

Steps:

- First turn off refrigeration, then disconnect electrical power. Turn off case power at breaker. Make sure all unused light receptacles have their close-off covers securely attached.
- Remove the product and all loose debris to avoid clogging the waste outlet.
- Store product in a refrigerated area such as a cooler. Remove only as much product as can be taken to the cooler in a timely manner.
- Thoroughly clean all surfaces with soap and warm water. Do not use steam or high water pressure hoses to wash the interior. These will destroy the merchandisers' sealing causing leaks and poor performance.
- Lift hinged fan plenum for cleaning. Hook chain in rear panel to secure plenum during cleaning. Be sure to reposition the fan plenum after cleaning merchandiser.
- Take care to minimize direct contact between fan motors and cleaning or rinse water.
- Rinse with warm water, but do not flood. Never introduce water faster than the waste outlet can remove it.
- Allow merchandisers to dry before resuming operation.
- Wipe down lighted shelves with a damp sponge or cloth so that water does not enter the light channel.
- After cleaning is completed, turn on power to the merchandiser.

Insight® Single and Multideck

Maintenance and Service

Cleaning Honeycomb Assemblies

Honeycombs should be cleaned every six months, or depending on store environment the honeycombs may need to be cleaned more often. Dirty honeycombs will cause cases to perform poorly.

The honeycombs may be cleaned with a vacuum cleaner. Soap and water may be used if all water is removed from the honeycomb cells before replacing. Be careful not to damage the honeycombs.



1. Remove honeycomb by pulling clip as shown above.
2. Clean and dry the honeycomb.
3. Honeycomb is symmetrical.
4. After cleaning, replace honeycomb. Ensure clip is centered and engaged along full-length of honeycomb.

Damaged honeycomb must be replaced.

Cleaning Mirrors

Mirrors are sheets of clear glass that have very thin reflective and protective coatings applied to one side. These coatings are susceptible to deterioration if certain cleaning solutions and even water are allowed to come in contact with them. Every precaution should be taken to keep all liquids away from the coated side of the mirrors. If liquids are allowed to flow along the face side of the mirror to its edge, the liquid can seep up between the coating and the glass, causing serious damage. Do not use hot water on cold glass surfaces. Doing this can cause the glass to shatter and could result in personal injury. Allow glass fronts, end and service doors to warm before applying hot water.

To Help Prolong the Life of the Mirrors:

Use only mild cleaning solutions that do not leave residue, such as a weak (10%) solution of vinegar and water. Do not spray liquids on the mirrors. Away from food, dampen the cleaning cloth, then use the cloth to wipe the mirror. Wipe water from the mirrors immediately to prevent difficult to remove water spots and also to prevent the water from reaching the mirror's edge. Never use dirty cloths, scrapers or any other abrasive materials for cleaning.

Insight® Single and Multideck

Maintenance and Service

Removing Interior Back Panels

The interior back panels may be removed for cleaning and to gain access to the evaporator coils. Remove the rear interior back panels as follows:

1. Disconnect the electrical power to the merchandiser.
2. Unplug shelf lights and insert plastic protective cap. Remove shelving.
3. Remove the lower panel first: lift the panel up, then pull forward and out.
4. Remove the top panel.
5. Replace panels in reverse order, starting with the top panel.



Cleaning Under Display Cases

Remove splashguards not sealed to floor. Use a vacuum with a long wand attachment to remove accumulated dust and debris from under the merchandiser.

Cleaning Coils

Never use sharp objects around coils. Use a soft brush or vacuum brush to clean debris from coils. Do not puncture coils! Do not bend fins. Contact an authorized service technician if a coil is punctured, cracked or otherwise damaged.

ICE in or on the coil indicates the refrigeration and defrost cycle is not operating properly. Contact an authorized service technician to determine the cause of icing, and to make adjustments as necessary. To maintain product integrity, move all product to a cooler until the unit has returned to normal operating temperatures.

- Do not puncture coils!
- Do not bend fins. Contact an authorized service technician if a coil is punctured, cracked, or otherwise damaged.
- Do NOT use chlorine or ammonia-based cleaners to clean aluminum coils.

Cleaning Stainless Steel Front Rails

Use non-abrasive tools, and always polish with grain of the steel. Use alkaline chlorinated or non-chlorine containing cleaners. Do not use cleaners containing salts as this may cause pitting and rusting of the stainless steel finish. Clean frequently to avoid build-up of hard, stubborn stains. Rinse and wipe dry immediately after cleaning. Never use hydrochloric acid (muriatic acid) on stainless steel.

Removing Scratches from Bumper

Most scratches and dings can be removed using the following procedure.

- Use steel wool to smooth out the surface area of the bumper.
- Clean area.
- Apply vinyl or car wax and polish surface for a smooth glossy finish.

Insight® Single and Multideck

Maintenance and Service

Recommended Cleaning Instructions

The directions below are recommended cleaning instructions for Insight display cases and should not be used as a substitute for the store's regular maintenance schedule. Follow all local and national health codes. Cleanliness of the case encourages long-lasting life of the equipment. This guide lists some of the key areas of the cases that require cleaning to help maintain the overall appearance and performance of the equipment and keep it free of debris. The cases may need additional cleaning, especially in high traffic areas, dusty areas and during unusually extended periods of use of the equipment.

Weekly or Monthly

1. Remove the product and store it in a separate case or a suitable walk-in cooler.
2. Take out the wire racks and bottom pans, and clean them in warm, soapy water. Rinse them thoroughly and set them aside.
3. Turn off the power to the case at the breaker.
4. If necessary, flip up the fan plenum assembly to create more space for cleaning.
5. Remove all loose debris and food particles that could clog the drain. Check the drain to ensure it is not obstructed. Avoid forcing items down the drain; use the drain catch to remove debris and dispose of it properly.
6. Remove the honeycomb and price display molding.
7. Clean all surfaces, including shelves and the honeycomb, by spraying them with warm water and mild detergent. Use a brush or cleaning pad if necessary to help remove dirt.
8. Rinse all surfaces with clean water, then spray them with a sanitizer. After allowing the sanitizer to sit for a moment, rinse it off with clean water using a hose. Let the surfaces air dry, as wiping them could undermine the sanitization process.
9. Carefully replace all internal parts, ensuring they are seated properly for optimal case performance.
10. Turn the power to the fans back on at the breaker.
11. Replace the product.

Quarterly or Semiannually

1. Remove product; store it in another case or suitable walk-in cooler.
2. Take out the wire racks and bottom pans, and clean them in warm, soapy water. Rinse them thoroughly and set them aside.
3. Turn off the power to the case at the breaker.
4. Flip up the fan plenum assembly to provide more room for cleaning in the case if necessary.
5. Remove all loose debris and food particles that may clog drain. Check drain to make sure it is not clogged. Do not force items down drain, use the drain catch to remove debris and dispose.
6. Remove honeycomb and price display moulding.
7. Clean all surfaces including shelves and honeycomb by spraying down water (preferably warm) and mild detergent. Use a brush or cleaner pad if necessary to aid in penetrating dirt.
8. Remove all the shelves and set aside then remove the back panels.
9. Clean the backside of the back panels in the case as you remove them.
10. Clean the newly exposed surfaces and the coil by spraying down with water (preferably warm) and a mild detergent solution.
11. Rinse the newly exposed surfaces and the coil with water then spray with a sanitizer. Allow surfaces to air-dry, since wiping would defeat the purpose of sanitizing.
12. Replace the back panels and shelves.
13. Rinse all surfaces with water, then spray with a sanitizer. Allow surfaces to air-dry since wiping would defeat the purpose of sanitizing.
14. Replace all remaining internal parts carefully so that they seat properly. This is necessary for proper case operation.
15. Turn the power to the fans back on at the breaker.
16. Replace the product.

Insight® Single and Multideck

Maintenance and Service

Troubleshooting

This guide is designed to help identify, diagnose and resolve common issues.

Issue	Possible Cause(s)	Potential Solution
case temperature is too warm	ambient conditions may be affecting the case operation.	ensure case is not positioned near sources of air disturbances such as open doors, windows, electric fans, or air conditioning vents; case must be located at least 15 feet away from any doors or windows; check ambient design conditions on the serial plate
	discharge air temp is out of specified range	check evaporator fan operation check electrical connections and input voltage
		fans are installed backwards; check airflow direction
		make sure fan blades have correct pitch and are per specification
		check to see that fan plenum is installed correctly with no air gaps
		check suction pressure and ensure that it meets factory specifications case is in defrost; check defrost settings see technical datasheet
product is outside of the load limit area, blocking airflow	redistribute product so it does not exceed load limit there is a sticker on the inside of the case indicating the maximum load limit	
coil is freezing over. condensing coil or evaporator coil is clogged or dirty	return air is blocked, make sure debris is not blocking the intake section	
	coil close-offs are not installed. Inspect coil to make sure these parts are on the case	
	clean coil	
case temperature is too cold	t-stat temp is set too low	check settings; see technical specifications on the datasheet
	ambient conditions may be affecting the case operation	ensure case is not positioned near sources of air disturbances such as open doors, windows, electric fans, or air conditioning vents; case must be located at least 15 feet away from any doors or windows; check ambient design conditions on the serial plate
frost or ice on evaporator coil	evaporator fans are not functioning	check electrical connections
	defrost clock is not functioning	case should be serviced by a qualified service technician
	coil is freezing over	return air is blocked, make sure debris is not blocking the intake section
coil close-offs are not installed. Inspect coil to make sure these parts are on the case		
coil freezing	lack of airflow over the coil	check for proper clearance and installation location
		coil is clogged or dirty - clean coils
		check fans for cleanliness and proper function
	low refrigerant charge/pressure	check system charge/pressure
check system piping to ensure there are no problematic restrictions or design features check for abnormal pressure drops at metering devices and valves		
water has pooled under case; case not draining properly	case drain is clogged.	clear drain.
	PVC drains under case may have a leak.	repair as needed.
	case tub has unsealed opening.	seal as needed.
	if case is in a lineup, case-to-case joint is missing	install case-to-case joint and seal as needed.
	evaporator pan is overflowing	check electrical connections to evaporation pan; check pan float assembly
	case is not level	ensure case is level using metal shims as necessary
	drain screen or p-trap clogged	clear debris
lights do not come on	LED driver / light socket wiring	check electrical connections
	LED driver needs to be replaced	case should be serviced by a qualified technician
	LED fixture socket / connection	case should be serviced by a qualified technician
	LED fixture needs to be replaced	lighting should only be replaced with like parts contact your Hussmann representative
	light switch needs to be replaced	case should be serviced by a qualified service technician

Insight® Single and Multideck

Maintenance and Service

Refrigerant Removal, Evacuation, and Recovery

WARNING: Always use a pressure regulator when operating nitrogen tanks.

WARNING: Never trap liquid refrigerant between closed valves as this could cause a hydraulic explosion.

When breaking into the refrigerant circuit to make repairs—or for any other purpose—conventional procedures shall be used. However, for flammable refrigerants it is important that best practice be followed, since flammability is a consideration. The following procedure shall be adhered to:

- a. Safely remove refrigerant following local and national regulations
- b. Purge the circuit with inert gas
- c. Evacuate
- d. Purge with inert gas
- e. Open the circuit by cutting or brazing

The refrigerant charge shall be recovered into the correct recovery cylinders if venting is not allowed by local and national codes. The system shall be purged with oxygen-free nitrogen to render the appliance safe for flammable refrigerants. This process might need to be repeated several times. Compressed air or oxygen shall not be used for purging refrigerant systems.

Refrigerants purging shall be achieved by breaking the vacuum in the system with oxygen-free nitrogen and continuing to fill until the working pressure is achieved, then venting to atmosphere, and finally pulling down to a vacuum. This process shall be repeated until no refrigerant is within the system. When the final oxygen-free nitrogen charge is used, the system shall be vented down to atmospheric pressure to enable work to take place.

Nitrogen and moisture will remain in the system unless proper evacuation procedures are followed. Nitrogen left in the system may cause head pressure problems. Moisture causes EEV ice blockage, wax build up, acid oil, and sludge formation.

Do not simply purge the system. This procedure is expensive, harmful to the environment, and may leave moisture and nitrogen behind.

Do not run the compressors to evacuate. This procedure introduces moisture into the compressor's crankcase oil and does not produce adequate vacuum to remove moisture from the rest of the system at normal temperatures.

Ensure that the outlet for the vacuum pump is not close to any potential ignition sources and that ventilation is available.

Insight® Single and Multideck

Maintenance and Service

Recovery Procedure

When removing refrigerant from a system, either for servicing or decommissioning, it is recommended good practice that all refrigerants are removed safely. When transferring refrigerant into cylinders, ensure that only appropriate refrigerant recovery cylinders are employed. Ensure that the correct number of cylinders for holding the total system charge is available.

All cylinders to be used are designated for the recovered refrigerant and labeled for that refrigerant (i.e., special cylinders for the recovery of refrigerant). Cylinders shall be complete with pressure-relief valve and associated shut-off valves in good working order. Empty recovery cylinders are evacuated and, if possible, cooled before recovery occurs.

The recovery equipment shall be in good working order with a set of instructions concerning the equipment that is at hand and shall be suitable for the recovery of all appropriate refrigerants including, when applicable, FLAMMABLE REFRIGERANTS. In addition, a set of calibrated weighing scales shall be available and in good working order. Hoses shall be complete with leak-free disconnect couplings and in good condition. Before using the recovery machine, check that it is in satisfactory working order, has been properly maintained and that any associated electrical components are sealed to prevent ignition in the event of a refrigerant release. Consult manufacturer if in doubt.

The recovered refrigerant shall be returned to the refrigerant supplier in the correct recovery cylinder, and the relevant waste transfer note arranged. Do not mix refrigerants in recovery units and especially not in cylinders.

If compressors or compressor oils are to be removed, ensure that they have been evacuated to an acceptable level to make certain that FLAMMABLE REFRIGERANT does not remain within the lubricant. The evacuation process shall be carried out prior to returning the compressor to the supplier. Only electric heating to the compressor body shall be employed to accelerate this process.

When oil is drained from a system, it shall be carried out safely.

Leak Detection (all refrigerants)

Under no circumstances shall potential sources of ignition be used in the searching for or detection of refrigerant leaks. Do not unplug any device if a leak is detected or suspected. A halide torch (or any other detector using a naked flame) shall not be used. The following leak detection methods are deemed acceptable for all refrigerant systems:

- Electronic leak detectors may be used to detect refrigerant leaks but, in the case of FLAMMABLE REFRIGERANTS, the sensitivity might not be adequate, or might need recalibration. (Detection equipment shall be calibrated in a refrigerant-free area.) Ensure that the detector is not a potential source of ignition and is suitable for the refrigerant used. Leak detection equipment shall be set at a percentage of the LFL of the refrigerant and shall be calibrated to the refrigerant employed, and the appropriate percentage of gas (25% maximum) is confirmed.
- Leak detection fluids are also suitable for use with most refrigerants but the use of detergents containing chlorine shall be avoided as the chlorine can react with the refrigerant and corrode the copper pipe-work.

Note: Examples of leak detection fluids are bubble method and fluorescent method agents.

If a leakage of refrigerant is found which requires brazing, all of the refrigerant shall be recovered from the system, or isolated (by means of shut off valves) in a part of the system remote from the leak. Removal of refrigerant shall be according to the Refrigerant Recovery section provided.

Insight® Single and Multideck

Maintenance and Service

A2L Leak Detection Sensor Service and Mitigation

WARNING

- Do not drop or apply direct impact to the sensor.
- Do not apply any sharp-pointed items to the membrane filter. A broken filter will damage the water protection feature and accuracy in detection.
- Do not cover the membrane filter.
- Do not apply any air or liquid flow with high pressure.
- Do not install the sensor on curved surfaces unless the sensor remains securely fixed without bending.
- The sensor should NOT be mounted with the membrane and sensor exposed to protect the sensor from contamination and moisture.
- Do not expose the detector to temperatures above 248° F (120° C); the plastic housing may become deformed.
- Do not spray any cleaning agents on the sensor.
- Do not clean the device with corrosive chemical products, solvents, or abrasive detergents.
- Clean the enclosure only with a damp cloth. Electrostatic spark risk.
- If a leak is suspected, all naked flames shall be removed/extinguished.
- The use of silicon sealant can inhibit the effectiveness of some types of leak detection equipment. Intrinsically safe components do not have to be isolated prior to working on them.
- **IMPORTANT—Electrostatic Spark Risk—**Disconnect all electrical connections and pass a damp cloth on the detector enclosure before performing any maintenance.

It is recommended to always have spare sensors on-hand to prevent system from being down for an extended period in the event of a sensor expiration or failure.

A2L-equipped equipment comes with pre-installed Danfoss sensors. If your equipment uses A2L and has a different sensor or no sensor present as indicated, contact Hussmann immediately before proceeding with service or maintenance.

It is important not to relocate, remove, or disable any factory leak detection devices. These components must be replaced with the same exact part by authorized service personnel only.

Insight® Single and Multideck

Maintenance and Service

Sensor Parts List

Danfoss System	
Part Description	Part Number
R-454A sensor	3216202
R-454C sensor	3216203
12-inch (305 mm) sensor harness	3216204
40-inch (1 m) sensor harness	3216206
60-inch (1.5 m) sensor harness	3216207
100-inch (2.5 m) sensor harness	3216208
240-inch (6.1 m) sensor harness	3216209

Sensor Specifications and Wiring

Specification	Value
Electrical Voltage	24 VAC +/- 10% and 24 VDC (8–32 VDC)
Compatible Refrigerant	R-454A or R-454C (as specified)



Pin Number	Function	Harness Wire Color (at sensor connection)
Pin 1	Supply Voltage	red
Pin 2	Earth/Ground	black
Pin 3	Mod A (Data +) (not used)	white
Pin 4	Mod B (Data -) (not used)	blue
Pin 5	Input Relay	yellow
Pin 6	Normally Open Contacts Output	orange

Relay Operation

- Relay is energized on power up when not in alarm state
- Relay is de-energized in alarm or no power state

Insight® Single and Multideck

Maintenance and Service

Sensor Mitigation and Alarms

When the sensor is powered on, an LED positioned on the back of the sensor near the sensor membrane indicates its status. When the sensor is mounted, the LED backlights the sensor and can be seen as a reflection on the mounting surface.

	Solid green	-Sensor power-up and self-test
	Blinking green	-Normal operation (heartbeat)
	Solid red	-Alarm state – gas detected
	Blinking red	-Sensor fault



When the sensor detects a gas reading at or above the alarm threshold, the relay de-energizes, causing the relay contacts to open during the alarm. Additionally, the alarm flag is set in the alarm status register.

To reset the alarm, the sensor reading must drop at least 2.5% below the alarm threshold. Once this happens follow instructions in the 'Sensor Reset Instructions' section below. After completing this, the relay re-energizes and the sensor returns to normal operation. The alarm flag is also cleared by these actions. After the alarm is reset, the relay remains open for five seconds before resuming normal operation.

Note: If not manually reset, the sensor will not automatically reset for approximately 24 days.

Self-diagnostics are performed when the sensor is first powered on. If a fault is detected the sensor LED will begin to blink red approximately 5 seconds after being powered on. These tests ensure the integrity of the memory, embedded program, and power supply.

The sensor continuously performs diagnostics to monitor its integrity, checking for issues such as shorts, open circuits, out-of-range values, and communication errors, as well as the integrity of the on-board memory, programming, oscillator, and voltage levels.

Insight® Single and Multideck

Maintenance and Service

Sensor Position

Refrigerant leak sensors in Insight multideck (4-, 5-, and 6-deck) cases are installed at the center of each coil and on top of the case, inside the isolation shut-off valve enclosure. See images below and on the next page for Insight short cases (single-deck, 2-, and 3-deck cases).



Insight® Single and Multideck Maintenance and Service

Sensor Position

A2L refrigerant leak sensors in Insight short cases are installed at the center of each coil and beneath the right side of the case, inside the isolation shut-off valve enclosure.



Insight® Single and Multideck

Maintenance and Service

Sensor System Check

These steps should be used to verify proper operation at system startup and periodically (at least annually) during normal maintenance.

Warning: The lighter used for testing should never be struck or lit to cause a spark or flame at any point, it is only being used for the gas it emits.

1. Power on sensor 1 and let it complete initialization routine.
2. Green light should be active (normal status/blinking).
3. Expose sensor 1 to mixture by holding the button on a lighter without touching the striker (it should trigger in less than 60 seconds). The end of the lighter the gas comes out will need to be placed near the base of the sensor where it mounts to the unit.
4. Verify that sensor 1 triggers an alarm (open/de-energized inside relay) and switches to red light.
5. Verify that the liquid shut-off solenoid(s) are de-energized and closed.
6. Verify that ventilation fans are activated (if applicable).
7. Wait five minutes, then manually reset the sensor using the procedure in the following section and verify it is in normal state.
8. If the case has multiple sensors, repeat steps 3-7 for each remaining sensor.

If needed, the system (external to the sensor) can also be tested independently by opening the circuits that go to pin #5 and #6 wherever possible in the wiring harness without cutting. This would simulate the sensor detecting a leak and allow the shut-off valve(s) and ventilation (if applicable) function to be tested. If this method is used, ensure any disconnected wiring is reconnected and perform the reset procedure (in the following section) before finishing service/inspection.

Insight® Single and Multideck

Maintenance and Service

Sensor Reset Instructions (after leak event or test)

1. Verify Safe Conditions
 - Confirm that there is no active refrigerant leak and that the environment is safe to proceed.
 - Ensure all personnel involved are properly trained and authorized to perform reset operations.
2. Access Control Panel
 - Open the electrical control panel where the power for leak detection system is installed.
3. Locate the Toggle Switch
 - Inside the control panel, identify the designated switch assigned for the leak sensor power control.
4. Perform Power Cycle Reset
 - Flip the toggle switch to the OFF position to remove power from the leak detection sensor.
 - Wait approximately 5–10 seconds to allow the sensor and associated safety circuits to fully de-energize.
 - Flip the toggle switch back to the ON position to reapply power.
5. Confirm System Reset:
 - Verify that the sensor alarm has been cleared.
 - Confirm that all safety valves have returned to their normal operating state.
 - Observe the system for any abnormal indicators or alarm recurrence.

Sensor Replacement

Replacement sensors should be of the same type and mounted in the original locations and orientation only.

- Max torque for screws is 6.2 lb-in (0.7 N-m)
- Mounting holes are sized for #10– #12 self-tapping sheet metal screws
- Recommended installation position is with connector down. When this is not possible, rotation up to 90 degrees left or right is acceptable.



Mount Sensor with cable facing downward if possible. This is to minimize Water ingress from the cable and connector.



Alternative mounting if downward is not possible. Cable can exit 90 degrees from right or left side. Any angle from downward 0 degrees up to 90 degrees can be used.



Replacement Steps

1. Before replacing sensor, first ensure no refrigerant leak is detected and then that the power is off. Also, ensure the exact same sensor part number is being used as a replacement by comparing the two sensors.
2. Remove two mounting screws from sensor.
3. Disconnect wires from relay and controller.
4. Attach new sensor in the same orientation and position with the previously removed screws.
5. Connect wiring to relay and controller per the wiring diagram.
6. Reconnect power. The refrigerant sensor should now run through the initialization process.

Insight® Single and Multideck

Maintenance and Service

Component Replacement

Replacing Fan Motors and Blades

WARNING

Always disconnect the electrical power at the main disconnect when servicing or replacing any electrical component. This includes, but is not limited to, such items as doors, lights, fans, heaters, and thermostats.

The fan motor harness plug must be properly secured. This connection should only be disconnected or connected by a qualified contractor and only in the event of fan motor replacement. Should it ever be necessary to service or replace the fan motors or blades, be certain that the fan blades are reinstalled correctly.

WARNING

STOP - DO NOT UNPLUG

All case cleaning and maintenance procedures should be performed with the power disconnected at the breaker. Failure to adhere to these instructions can lead to damage to the unit and creates the risk of flammability or electrical shock. The fan motor harness plug **MUST** be properly secured in order to achieve its IP68 rating.

This connection should **ONLY** be disconnected / connected by a qualified contractor and **ONLY** in the event of fan motor replacement. The fan motor harness should not be disconnected / connected in performing any other cleaning, service, or repair. Refer to the installation, operation and services manual for sequence of repair.

» Warning: Before obtaining access to terminals, all supply circuits must be disconnected.

Insight® Single and Multideck

Maintenance and Service

To access and replace fan motor:

1. Turn off case power at breaker.
2. Remove bottom display pans.
3. Unpack new motor/harness assembly and set aside outside of case.
4. Remove screws holding existing fan motor bracket assembly to plenum, and remove assembly from plenum.
5. Disengage and unplug existing motor harness connector; remove existing motor.
 - a. Grasp the plug and receptacle, and apply slight pressure to pull apart. The connector should not separate without depressing the locking tab.
6. Taking care to avoid any existing moisture in the case, IMMEDIATELY connect and lock new motor harness as follows:
 - a. Align the plug and receptacle, and push together until the locking tab engages. Locking tab must engage in the window of receptacle and not separate.
7. Place new fan motor assembly back into plenum, and reinstall screws to secure.
8. Turn on power.
9. Verify that motor is working and blade is turning in the correct direction.
10. Close air gaps under fan plenum. Warmer air moving into refrigerated air reduces effective cooling. If the plenum does not rest against the case bottom without gaps, apply foam tape to the bottom of the fan plenum to reduce improper air movement. Use silicone sealant to close other gaps.
11. Replace display pans. Bring merchandiser to operating temperature before restocking.

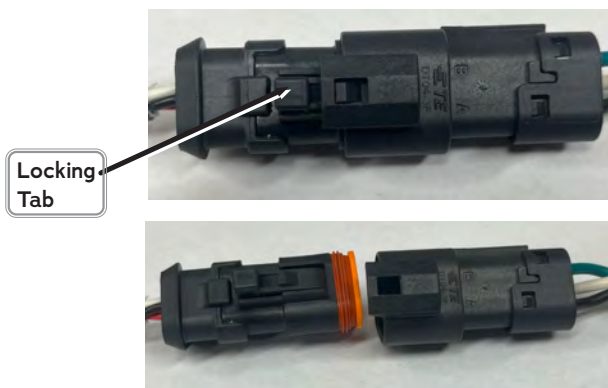

Insight® Single and Multideck

Maintenance and Service

Replacing Door Handles

(for cases with doors)

These doors have glued on studs. If the handle is broken it should be replaced along with the stud.

1. Remove stud from door (if needed). Wear gloves to safely remove the stud using a razor blade. A hammer could be used to assist with removing the stud by gently tapping on razor blade.
2. Remove excess glue. Wearing gloves, use razor blade to remove the excess glue from the door.
3. Clean the glass surface. Apply isopropyl alcohol to the surface of the glass and wipe using a paper towel until dry.
4. Using a new stud, apply isopropyl alcohol to the surface of the stud and wipe using a paper towel until dry.

Note: Do not use original studs, they may contain residue that prevents the stud from adhering to the glass.



1.

Replacement Parts

Kit	Description	Components in Kit	Order
ABB91	Retrofit studs only	2 studs only, 2 sets screws, instructions	Replace 1 or 2 studs only - have original handle
ABB92	Retrofit black handles and studs	2 studs, one black handle assembly, 2 set screws	Replace black handle, 2 studs, 2 set screws
ABB93	Retrofit black handles and studs	2 studs, one gray handle assy, 2 set screws	Replace gray handle, 2 studs, 2 set screws
ABB94	Glue and Template	adhesives and template	Template and adhesives for repairing 4 to 6 handles.



2. & 3.

Tools and Supplies Needed:

Provided Items

EcoVision Stud: P/N 3119359

Glue: Permatex Kit (adhesive and activator)

Template

Not Provided Items

Hammer, if needed

Razor

Isopropyl Alcohol

Paper Towels

Tape

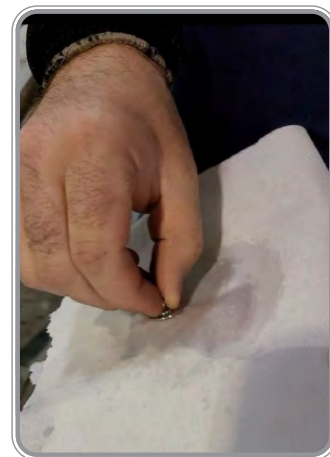

4.

Insight® Single and Multideck Maintenance and Service

5. Open Permatex package. Clean the area, then attach template.

Note: Repair one handle at a time. Complete all steps on a single handle before repairing additional handles. The temperature of the glass should be between 65 and 85 degrees, and door should be dry when applying the stud



Adhesive should repair 4 to 6 handles.



Open Package



Open/cleaner activator towelette.
Towelette is to remain in package.
Read directions on towelette package.



Wipe the area where the stud goes with a towelette. Allow to dry for 1 minute. Do not touch glass again.



Attach template to door over existing stud location. Use tape or clamp to secure.

Insight® Single and Multideck Maintenance and Service

6. Apply Permatex to the stud.

Let stud cure for 30 minutes, then reinstall handle(s), and tighten set screw(s) until they are flush with handle.



Wipe the flat surface of the stud. Allow to dry for 1 minute. Do not touch clean surface again.



Remove cap from adhesive.



Cut tip of adhesive.



Apply two drops of adhesive to stud only, none to the glass.



By hand, firmly press the stud to the glass, and hold for one minute.



Wipe away any excess glue with isopropyl alcohol. Allow to set for 30 minutes. Reattach handle.

Insight® Single and Multideck

Decommissioning

Decommissioning Process

Before carrying out this procedure, it is essential that the technician is completely familiar with the equipment and all its details. It is recommended good practice that all refrigerants are recovered safely. Prior to the task being carried out, an oil and refrigerant sample should be taken in case analysis is required prior to re-use of recovered refrigerant. It is essential that electrical power is available before the task is commenced.

- a. Become familiar with the equipment and its operation.
- b. Isolate the system electrically.
- c. Before attempting the procedure, ensure:
 - i. Mechanical handling equipment is available, if required, for handling refrigerant cylinders.
 - ii. All personal protective equipment is available and being used correctly.
 - iii. The recovery process is supervised at all times by a qualified, competent person.
 - iv. Recovery equipment and cylinders conform to the appropriate standards.
- d. Pump down refrigerant system, if possible.
- e. If a vacuum is not possible, make a manifold so that refrigerant can be removed from various parts of the system.
- f. Make sure that cylinder is situated on the scales before recovery takes place.
- g. Start the recovery machine and operate in accordance with instructions.
- h. Do not overfill cylinders (no more than 80% volume liquid charge).
- i. Do not exceed the maximum working pressure of the cylinder, even temporarily.
- j. When the cylinders have been filled correctly and the process completed, make sure that the cylinders and the equipment are removed from site promptly and all isolation valves on the equipment are closed off.
- k. Recovered refrigerant shall not be charged into another refrigerating system unless it has been cleaned and checked.

Equipment shall be labeled stating that it has been decommissioned and emptied of refrigerant. The label shall be dated and signed. For appliances containing flammable refrigerants, ensure that there are labels on the equipment stating the equipment contains flammable refrigerant.

Warranty

To obtain warranty information or other support, contact your Hussmann representative or visit:

<https://www.hussmann.com/services/warranty>.

Please include the model and serial number of the product.

For questions about your equipment, please contact our Technical Support Team at 1-866-785-8499

For general support or service calls, contact our Customer Support Call Center at 1-800-922-1919

For ordering aftermarket warranty parts, call 1-855-HussPrt (1-855-487-7778) or email the following address:
Hussmann_part_warranty@hussmann.com

Revision History

Revision Y: Redesign; added A2L refrigerants

Revision W: Add CO₂ high pressure information; modified drain piping assembly, page 3-4; added splashguard assembly for ultra-low front cases, page 3-13

Revision V: Updated for Compliance with UL 60335

Revision U: Added French part number and updated contact information.

Revision T: Updated fan motor instructions; created Appendix

Revision S: manual not used or published



Scan the QR code on your mobile device to access additional product information or order parts using equipment serial number.

Parts may also be ordered at:
parts.hussmann.com
Call toll free: 1.855.487.7778

We reserve the right to change or revise specifications and product design in connection with any feature of our products. Such changes do not entitle the buyer to corresponding changes, improvements, additions or replacements for equipment previously sold or shipped.