

# HUSSMANN<sup>®</sup> *Excel*



**FWEL**  
Technical Data Sheet  
P/N 0523828\_E

**NSF<sup>®</sup> Certified**  
June 2021

**DOE 2017**  
Energy Efficiency  
Compliant

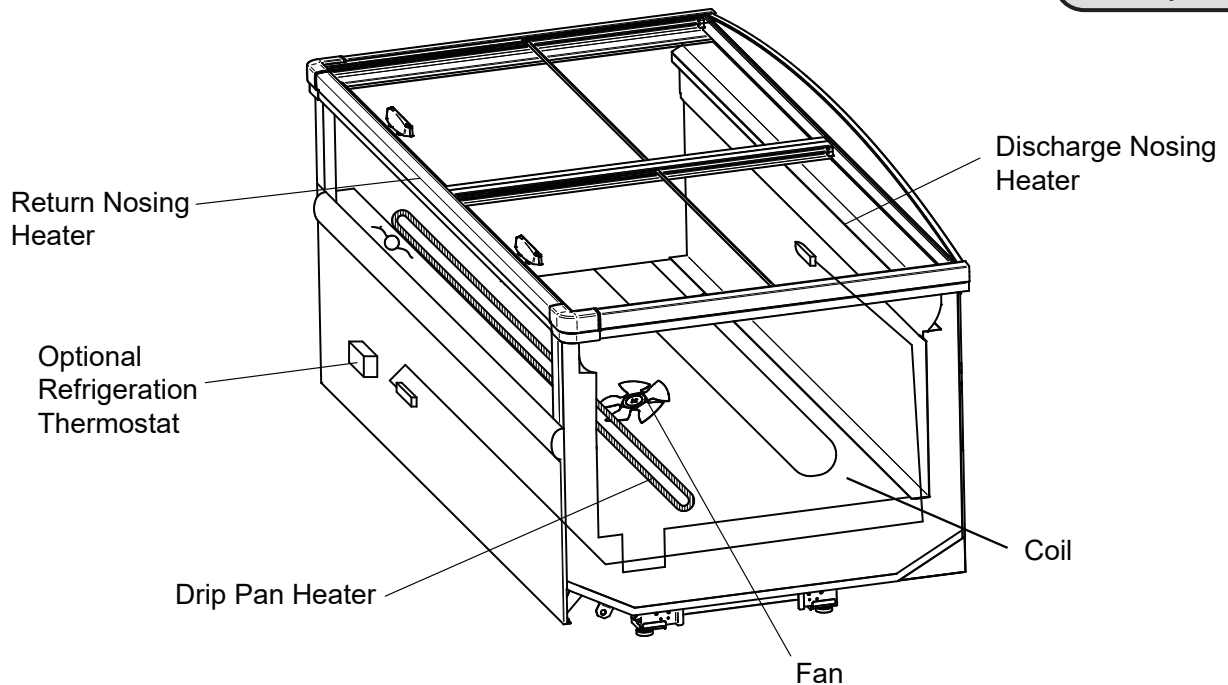

Scan the QR code on your mobile device to access additional product information or order parts.

Parts may also be ordered at:

[parts.hussmann.com](http://parts.hussmann.com)

Call toll free: 1.855.487.7778

We reserve the right to change or revise specifications and product design in connection with any feature of our products. Such changes do not entitle the buyer to corresponding changes, improvements, additions or replacements for equipment previously sold or shipped.

Data sheet-Excel-FWEL

Note: Revision E: Updated lid information.

# Engineering Plan Views

PHYSICAL DATA	
Merchandiser Drip Pipe (in.)	1 1/4
Merchandiser Liquid Line (in.)	3/8
Merchandiser Suction Line (in.)	5/8

## Low / Medium Temperature Wide Island End case

Dimensions shown as inches & (mm).

10-2004

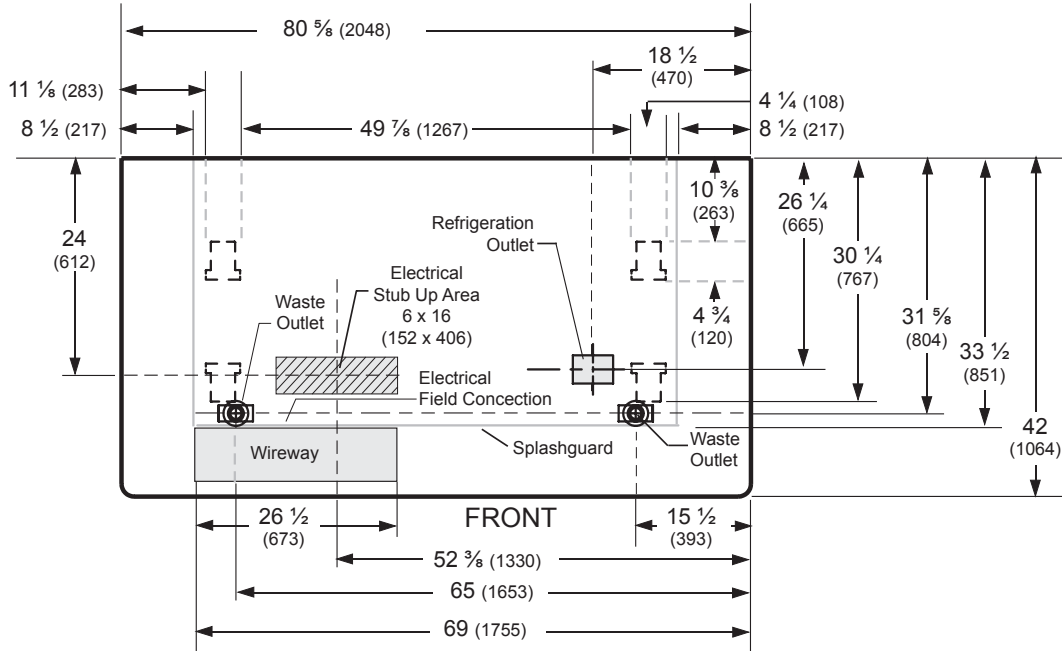

	End Case
<b>General</b>	
Case Length — Outside	80 5/8 (2048)
Inside Length	73 5/8 (1870)
Maximum O/S dimension of case back to front <i>(includes bumper)</i>	42 (1064)
Back of case to front of splashguard	33 1/2 (851)
Back of case to O/S edge of front leg	30 1/4 (767)
Distance between edges of external legs and center legs	48 1/2 (1234)
Distance between edges of center legs	NA
Distance between front legs and splashguard	3 1/8 (82)
<b>Electrical Service</b> <input checked="" type="checkbox"/> <i>(Electrical Field Wiring connection point)</i>	
RH End of case to center of stub up area	52 3/8 (1330)
Back of case to center of stub up area	24 (612)
Length of electrical wireway <input type="checkbox"/> Wireway	26 1/2 (673)
RH End of case to LH end of wireway	69 (1755)
<b>Waste Outlets</b> <i>(One each end)</i> <input checked="" type="checkbox"/>	
RH End of case to the center of LH waste outlet	65 (1653)
RH End of case to the center of RH waste outlet	15 1/2 (393)
Back O/S of case to center of waste outlets	31 5/8 (804)
Schedule 40 PVC drip pipe	1 1/4 (32)
<b>Refrigeration Outlet</b> <input checked="" type="checkbox"/>	
Back of case to center of refrigeration outlet	26 1/4 (665)
RH end of case to center of refrigeration outlet	18 1/2 (470)

Single Level End Display with Solid Front and Lids



Hussmann refrigerated merchandisers configured for sale for use in the United States meet or surpass the requirements of the DOE 2017 energy efficiency standards.

**Excel FWEL**

**Low / Medium Temperature**

**REFRIGERATION DATA\*\*§**

**Note:** This data is based on store temperature and humidity that does not exceed 75°F and 55% R.H.

	MED	FF	IC
Discharge Air (°F)	+32	-10	-19
Evaporator (°F)	+25	-15	-24
Unit Sizing (°F)	+23	-18	-27

§ Average evaporator temperature shown. Use dew point for high glide refrigerants for unit sizing. Care should be taken to use the dew point in PT tables for measuring and adjusting superheat. Adjust evaporator pressure as needed to maintain discharge air temperature shown.

Btu/hr/case*	MED	FF	IC
Parallel	488	922	974
Conventional	498	962	1016

\* Add 10 Btu/hr/case for LED lighting.

\*\*Dual temperature operation kits are not suitable for ice cream temperature applications.

**DEFROST DATA**

	MED	FF	IC
Frequency (hr)	24	24	24
Defrost Water (lb/case/day)	2.6	2.3	2.0

(± 15% based on case configuration and product loading).

<i>ELECTRIC</i>	MED	FF	IC
Temp Term (°F)	48	48	48
Failsafe (minutes)	30	50	60

<i>GAS</i>	MED	FF	IC
Duration (minutes)	NA	15	18

**OFFTIME** Not Recommended

**Standard Defrost Thermostat**

Close on rise: close 48°F — open 33°F

**CONVENTIONAL CONTROLS**

**Low Pressure Backup Control — CI/CO \*\***

MED	+28°F / +16°F
FF	-15°F / -27°F
IC	-21°F / -33°F

**Indoor Unit Only, Pressure Defrost Termination\*\*\***

Not Recommended

\*\*\*Use a Temperature Pressure Chart to determine PSIG conversions.

Dimensions shown as inches & (mm).

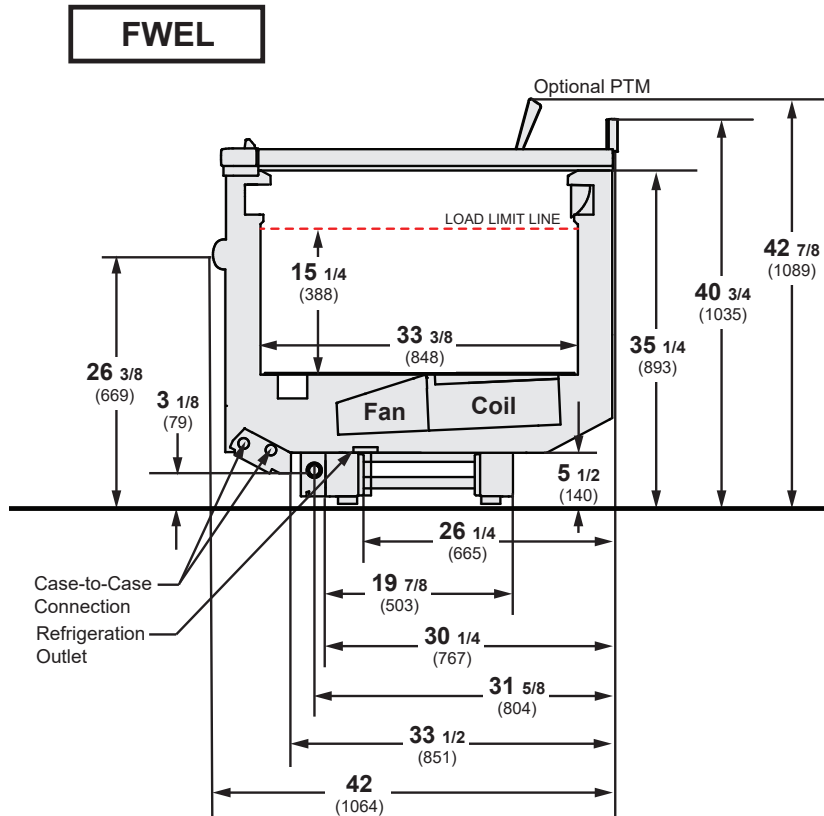

**Estimated Charge \*\*\*\***

End	1.5 lb	24 oz	0.7 kg
-----	--------	-------	--------

\*\*\*\*This is an average for all refrigerant types. Actual refrigerant charge may vary by approximately half a pound (8 oz/0.2 kg).

**Length Added to Lineup:** 42 (1064)

This End Case is used in place of an End Assembly. Partitions do not apply.

**NSF Certification**

This merchandiser model is manufactured to meet NSF/ANSI (National Sanitation Foundation) Standard #7 requirements for construction, materials & cleanability.

<b>Excel FWEL</b> <b>Low / Medium Temperature</b>
--

**Electrical Data**

			Standard End	
Number of Fans – 4W Evaporator			1	
			Amperes	Watts
			End	End
<b>Evaporator Fans</b>				
120V	50/60Hz	Standard Energy Efficient	0.12	8
230V	50/60Hz	Standard Energy Efficient	0.06	8
230V	60Hz	Export	0.15	24
230V	50Hz	Export	0.18	27
<b>Anti-sweat Heaters (on fan circuit)</b>				
120V	50/60Hz	Standard	0.20	24
230V	50/60Hz	Export	0.10	24
<b>Minimum Circuit Ampacity</b>				
120V	50/60Hz	Standard Energy Efficient	0.52	
230V	50/60Hz	Standard Energy Efficient	0.36	
230V	60Hz	Export	0.45	
230V	50Hz	Export	0.48	
<b>Maximum Over Current Protection 120V</b>			<b>20</b>	<b>20</b>
Maximum Over Current Protection 230V			15	15
<b>208V Electric Defrost</b>			6.54	1360
<b>230V Export Electric Defrost</b>			5.91	1360
<b>120V Koolgas Defrost</b>			1.33	160

ONLY LIGHTING CONFIGURATIONS THAT ARE COMPLIANT WITH THE U.S. DEPT. OF ENERGY (DOE) 2017 REGULATION ARE AVAILABLE FOR SALE FOR USE IN THE U.S.A.

**Standard Lighting**

None

**Optional Lighting**

LED	120V	50/60Hz	0.17	20
-----	------	---------	------	----

*Please note: some combinations of fluorescent lights on this case model may not be compliant with DOE 2017 and may not be available to order in the US and Canada. More lighting options are available with LED lights. The Hussmann Product Configurator will not allow lighting options that do not comply with the DOE 2017 standards.*

**Product Data**

<i>Recommended Usable Cube</i> <sup>1</sup> (Cu Ft/Ft)	3.54 ft <sup>3</sup> /ft (0.33 m <sup>3</sup> /m)
<i>AHRI Total Display Area</i> <sup>2</sup> (Sq Ft/Ft)	2.60 ft <sup>2</sup> /ft (0.79 m <sup>2</sup> /m)
<i>Shelf Area</i> <sup>3</sup> (Sq Ft/Ft)	2.79 ft <sup>2</sup> /ft (0.85 m <sup>2</sup> /m)

<sup>1</sup> AHRI Refrigerated Volume less shelving and other unusable space: Refrigerated Volume/Unit of Length, ft<sup>3</sup>/ft [m<sup>3</sup>/m]

<sup>2</sup> Computed using AHRI 1200 standard methodology: Total Display Area, ft<sup>2</sup> [m<sup>2</sup>]/Unit of Length, ft [m]

<sup>3</sup> Shelf surface area is composed of bottom deck plus standard shelf complement, as shown in the Hussmann *Product Reference Guide*. The standard shelf complement for this model is NONE.

**ESTIMATED SHIPPING WEIGHT <sup>4</sup>**

<b>Case</b>						<b>End Case</b>
<b>lb (kg)</b>	NA (NA)	NA (NA)	NA (NA)	NA (NA)	NA (NA)	590 (269)

<sup>4</sup> Actual weights will vary according to optional kits included.

**Glass Lid Replacement Parts**

- A. Glass Assembly - FXD end case FW
- B. Glass Assembly - Door FWE



Scan the QR code on your mobile device to access additional product information or order parts.

Parts may also be ordered at:

[parts.hussmann.com](http://parts.hussmann.com)  
Call toll free: 1.855.487.7778

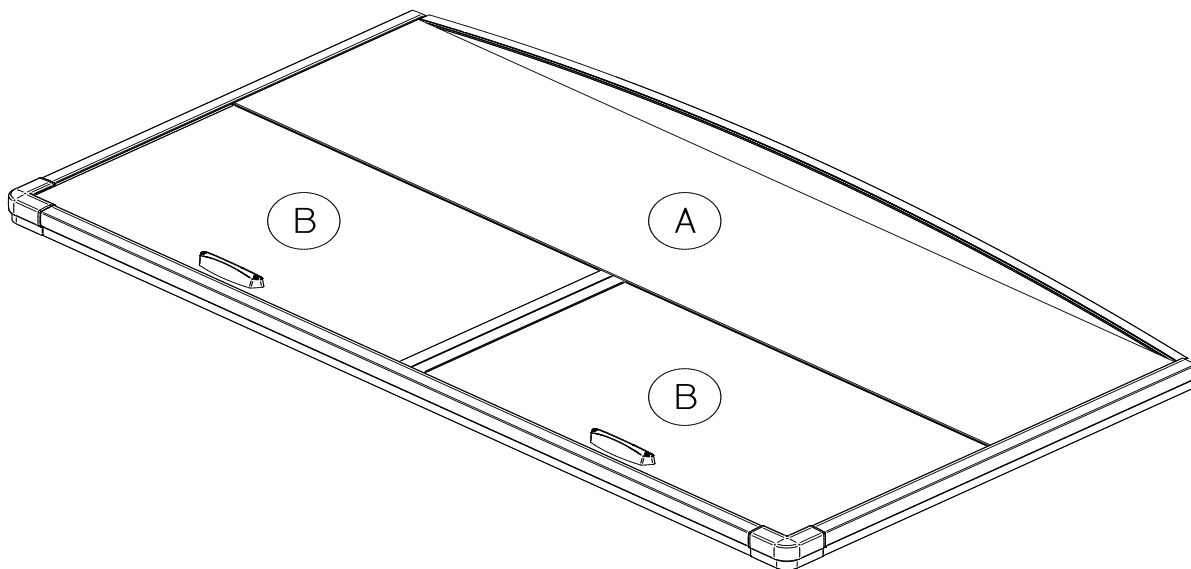

# Electric Defrost – Standard

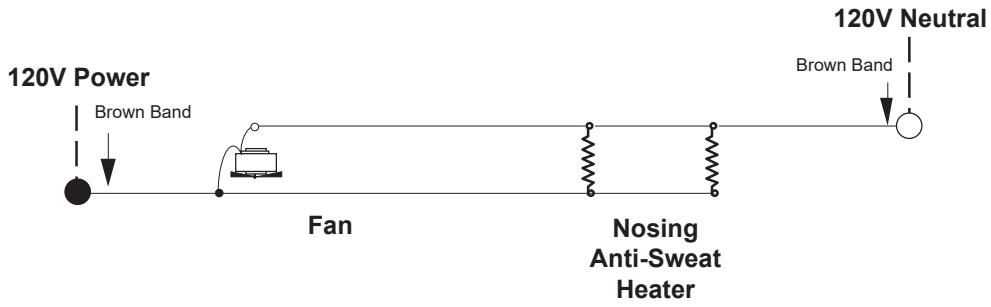

## Refrigeration Thermostat (Optional)

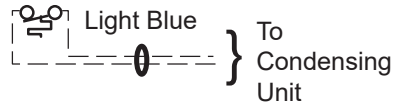

## Defrost Termination Thermostat

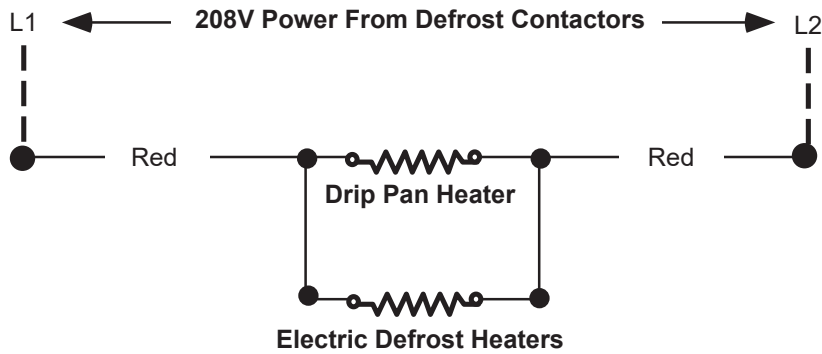
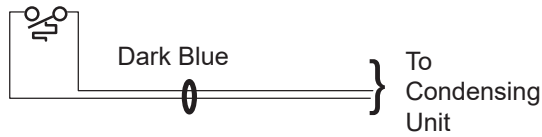

## WARNING

All components must have mechanical ground, and the merchandiser must be grounded.

# Gas Defrost – Optional

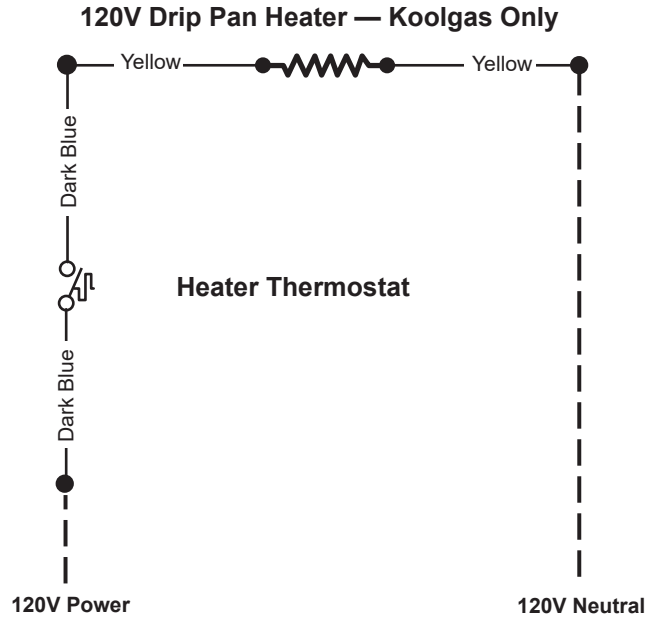

## WARNING

All components must have mechanical ground, and the merchandiser must be grounded.

## Optional LED Lighting Wiring Diagrams

