

HUSSmann®

Low Temperature **Single Deck Wall & Island Merchandisers** **with Glass Lids**



***Installation &
Operation Manual***
Shipped With Merchandiser
Data Sheets

IMPORTANT
Keep in store for
future reference!

P/N 3151475_D
March 2022



BEFORE YOU BEGIN

Read these instructions completely and carefully.



This manual was written in accordance with originally prescribed equipment that is subject to change. Hussmann reserves the right to change or revise specifications and product design in connection with any feature of our products.

PERSONAL PROTECTION EQUIPMENT (PPE)



Only qualified personnel should install and service this equipment. Servicing is only to be done by factory authorized personnel. Personal Protection Equipment (PPE) is required. Wear safety glasses, gloves, protective boots or shoes, long pants, and a long-sleeve shirt when working with this equipment and while handling glass. Observe all precautions on tags, stickers, labels and literature attached to this equipment. Component parts shall be replaced with like components. Service is to be performed by factory-authorized service personnel, so as to minimize the risk of possible ignition due to incorrect parts or improper service. Contact your Hussmann representative to arrange servicing.

ANSI Z535.5 DEFINITIONS

The safety of our customers and employees are paramount. The precautions and procedures described in this manual are intended as general methods for safe use of this equipment. Please be sure to comply with the precautions described in this manual to protect you and others from possible harm, and follow OSHA standards for safety.

The definitions at right are used to clarify the magnitude and urgency of harm and damage, considering problems arising from misuse. Relative to their potential danger, the definitions are divided into four parts according to ANSI Z535 Series.



• **DANGER** – Indicate[s] a hazardous situation which, if not avoided, will result in death or serious injury.



• **WARNING** – Indicate[s] a hazardous situation which, if not avoided, could result in death or serious injury.



• **CAUTION** – Indicate[s] a hazardous situation which, if not avoided, could result in minor or moderate injury.



• **NOTICE** – Not related to personal injury – Indicates[s] situations, which if not avoided, could result in damage to equipment.

TABLE OF CONTENTS

| | | | |
|---|------|---|------|
| BEFORE YOU BEGIN (SAFETY) | ii | DRIP PIPING AND SPLASHGUARDS | |
| ANSI Z535.5 DEFINITIONS | iv | Waste Outlet and Water Seal | 3-1 |
| EXCEL INSTALLATION TOOL LIST | iv | Installing Drip Piping | 3-2 |
| INSTALLATION | | Drip Piping Lineup Arrangements | 3-3 |
| UL Listing | 1-1 | Installing Splashguards | 3-4 |
| Federal / State Regulations | 1-1 | Installing Splashguard on End and End Case | 3-6 |
| Location | 1-1 | INSTALLING TRIM AND GLASS GABLES | |
| Shipping Damage | 1-2 | Installing Spacers | 4-1 |
| Unloading | 1-2 | Installing Decor Trim | 4-2 |
| Serial Plate Location | 1-3 | Attaching Gables (Flat Case Ends) | 4-3 |
| Exterior Loading | 1-3 | Attaching Gables (Contour Case Ends) | 4-4 |
| Merchandisers Shipped with End Installed | 1-3 | Installing PTMs | 4-5 |
| Shipping Braces | 1-3 | START UP / OPERATION | |
| Unpacking Lids Frames | 1-4 | Start Up | 5-1 |
| Case Shipping Rider | 1-4 | Stocking | 5-1 |
| Merchandiser Leveling | 1-4 | Installing FDA/NSF Required Thermometer | 5-1 |
| Leveling Wall Merchandisers | 1-5 | Load-Limits | 5-1 |
| Leveling Narrow, Intermediate, Wide Island or | | Load Limit Profiles | 5-2 |
| End Merchandisers | 1-5 | MAINTENANCE | |
| Joining Instructions | 1-6 | Care and Cleaning | 6-1 |
| Joining Merchandisers in Line | 1-7 | Fan Plenum | 6-1 |
| Joining End Merchandiser to Wide Island | 1-9 | Exterior Surfaces | 6-1 |
| Parent to Parent Installation KEY | 1-11 | Interior Surfaces | 6-1 |
| Parent to End Installation KEY | 1-13 | Cleaning Airflow Louvers | 6-2 |
| Fasten End Frames | 1-14 | Cleaning Wire Racks, Pans and Interior Panels | 6-2 |
| Seal Merchandisers | 1-15 | Cleaning Stainless Steel Rails | 6-2 |
| Installing Splashguard Brackets | 1-15 | Cleaning Coils | 6-3 |
| Replacing Interior Panels and Discharge | | Removing Rear Flue Glass | |
| Air Louvers | 1-15 | for Cleaning (FIG-L & FNG-L) | 6-4 |
| Offsetting Bumper | 1-16 | Cleaning Sliding Glass Lids | 6-4 |
| Bumper Removal | 1-16 | Removing Scratches from Bumper | 6-4 |
| Offsetting Bumper (for End Merchandisers) | 1-18 | Cleaning Under Merchandisers | 6-4 |
| Offsetting Bumper (for Merchandiser Lineup) | 1-19 | SERVICE | |
| Installing Flue Glass — FNG & FIG | 1-20 | General | 7-1 |
| Installing Flue Glass Clamp | | Replacing Fan Motors and Blades | 7-1 |
| (FWGH & FWEHG) | 1-20 | Replacing Cassette Glass | 7-2 |
| Installing Partitions | 1-20 | Cassette Frame Types | 7-6 |
| Installing End Assemblies | 1-21 | Removing Glass Door Lid Assemblies | 7-7 |
| REFRIGERATION / ELECTRICAL | | Replacing Electric Defrost Heater | 7-7 |
| Refrigerant | 2-1 | Replacing Return Air Heater | 7-8 |
| Refrigerant Piping | 2-1 | Replacing Nosing Anti-sweat Heater | 7-9 |
| Connection Location | 2-1 | Replacing Product Side Heater | |
| Multiplexing | 2-2 | (FWGH & FWEHG Only) | 7-10 |
| Line Sizing | 2-2 | Replacing Drip Pan Heater | 7-11 |
| Oil Traps | 2-2 | Replacing Discharge Thermopane Glass | |
| Pressure Drop | 2-2 | Assembly (FNG-L and FIG-L) | 7-12 |
| Insulation | 2-3 | Replacing Return Thermopane | |
| Branch Line Piping | 2-3 | Glass Assembly | 7-14 |
| Suction Line — All Defrosts | 2-3 | Power Supply & LED Replacement | 7-15 |
| Liquid Line — Off-time and Electric Defrost | 2-4 | Repairing Aluminum Coil | 7-16 |
| Liquid Line — Koolgas Defrost | 2-4 | WARRANTY | |
| Front to Rear and/or End Interconnects | 2-5 | | |
| Refrigeration Thermostat | 2-5 | | |
| Defrost Termination Thermostat | 2-5 | | |
| CDA Sensor (Optional) | 2-5 | | |
| Merchandiser Electrical Data | 2-6 | | |
| Field Wiring | 2-6 | | |
| Electrical Connections | 2-6 | | |
| Identification of Wiring | 2-6 | | |
| Wiring Color Code | 2-6 | | |

TOOL LIST

ANSI Z535.5 DEFINITIONS

-  • **DANGER** – Indicate[s] a hazardous situation which, if not avoided, will result in death or serious injury.
-  • **WARNING** – Indicate[s] a hazardous situation which, if not avoided, could result in death or serious injury.
-  • **CAUTION** – Indicate[s] a hazardous situation which, if not avoided, could result in minor or moderate injury.
- **NOTICE** – *Not related to personal injury* – Indicates[s] situations, which if not avoided, could result in damage to equipment.

Unloading From Trailer:

- Lever Bar (also known as a Mule, Johnson Bar, J-bar, Lever Dolly, and pry lever)
- Moving Dolly (two for 12-ft merchandiser)

Setting Merchandiser Line-Up:

- Level, 4 ft suggested
- Ratchet
- 1/4 in. Socket
- 5/16 in. Socket
- 1/2 in. Socket
- Battery Drill/Screw Gun
- Caulking Gun
- 10 in. Adjustable Crescent Wrench

REVISION HISTORY

REVISION D
Transitioned to a factory-installed lids configuration

REVISION C
Added new models

REVISION B
New Cover Rendering

ORIGINAL ISSUE — June 2021

INSTALLATION

UL LISTING

These merchandisers are manufactured to meet ANSI/ UL 471 standard requirements for safety. Proper installation is required to maintain the listing.

FEDERAL / STATE REGULATIONS

These merchandisers at the time they are manufactured, meet all federal and state/ provincial regulations. Proper installation is required to ensure these standards are maintained. Near the serial plate, each merchandiser carries a label identifying the environment for which the merchandiser was designed for use. A Type II fan speed control kit is required for each merchandiser to operate at Type II conditions.

ANSI/NSF-7 Type I – Display Refrigerator / Freezer
Intended for 75°F (24°C) / 55% RH Ambient Application

ANSI/NSF-7 Type II – Display Refrigerator / Freezer
Intended for 80°F / 55% RH Ambient Application

ANSI/NSF-7 – Display Refrigerator
Intended for Bulk Produce

LOCATION

These merchandisers are designed for displaying products in air conditioned stores where temperature is maintained at or below the ANSI / NSF-7 specified level and relative humidity is maintained at or below 55%. Placing refrigerated merchandisers in direct sunlight, near hot tables or near other heat sources could impair their efficiency.

Like other merchandisers, these are sensitive to air disturbances. Air currents passing around merchandisers will seriously impair their operation. Do NOT allow air conditioning, electric fans, open doors or windows, etc. to create air currents around the merchandisers. Product should always be maintained at proper temperature. This means that from the time the product is received, through storage, preparation and display, the temperature of the product must be controlled to maximize the life of the product.

Excel wall models have internal frames. A 3 inch (76 mm) space between the rear of the merchandiser and wall must be maintained for air circulation. However, in high ambient conditions, sweating may still occur. If this happens install a method of forced ventilation such as a fan ventilation kit.

Wide Island Fronts

BE SURE TO POSITION WIDE ISLAND MERCHANDISER FRONTS PROPERLY.

The front of a wide island merchandiser is readily identified by the location of the serial plate. Since all electrical and refrigeration connections will be made at the front side, the fronts will need to be positioned according to the store plan layout.

SHIPPING DAMAGE

All equipment should be thoroughly examined for shipping damage before and during unloading. This equipment has been carefully inspected at our factory. Any claim for loss or damage must be made to the carrier. The carrier will provide any necessary inspection reports and/or claim forms.

Apparent Loss or Damage

If there is an obvious loss or damage, it must be noted on the freight bill or express receipt and signed by the carrier's agent; otherwise, carrier may refuse claim.

Concealed Loss or Damage

When loss or damage is not apparent until after equipment is uncrated, retain all packing materials and submit a written request to the carrier for inspection, within 15 days.

UNLOADING

Improper handling may cause damage to the merchandiser when unloading.

To avoid damage:

1. Do not drag the merchandiser out of the trailer. Use a Johnson bar (mule).
2. Use one dolly to remove the merchandiser from the trailer.
3. Use two dollies to move cases to lineup.



This warning does not mean that Hussmann products will cause cancer or reproductive harm, or is in violation of any product-safety standards or requirements. As clarified by the California State government, Proposition 65 can be considered more of a 'right to know' law than a pure product safety law. When used as designed, Hussmann believes that our products are not harmful. We provide the Proposition 65 warning to stay in compliance with California State law. It is your responsibility to provide accurate Proposition 65 warning labels to your customers when necessary. For more information on Proposition 65, please visit the California State government website.

SERIAL PLATE LOCATION

Direct a flashlight through the return air grille to locate the serial plate. **BE SURE TO POSITION WIDE ISLAND MERCHANDISER FRONTS PROPERLY.** The front of a wide island merchandiser is readily identified by the location of the serial plate affixed to the inside of the left front assembly. Since all electrical and refrigeration connections will be made at the front side, the fronts will need to be positioned according to the store plan layout. A secondary serial number sticker is put on the exterior nosing on the discharge side. It provides the model, serial number and manufacture date.



Consult the serial number and model number for parts and warranty claims.

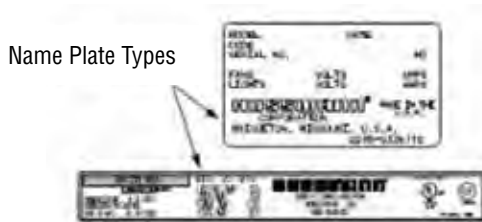

EXTERIOR LOADING

Do NOT walk on top of merchandiser, or damage to the merchandiser and serious personal injury could occur. **THEY ARE NOT STRUCTURALLY DESIGNED TO SUPPORT EXCESSIVE EXTERNAL LOADING** such as the weight of a person. Do not place heavy objects on the merchandiser’s glass lids.

MERCHANDISERS SHIPPED WITH END INSTALLED

Be careful not to damage the factory installed end while moving the merchandiser. Make sure that lifting tools are positioned past the end and beneath the support bar.

SHIPPING BRACES

Move the merchandiser as close as possible to its permanent location and then remove all packaging. Check for damage before discarding packaging. Remove all separately packed accessories such as kits and pan displays. Remove end braces, and discard hardware. Exercise caution at all times when moving merchandisers with up-tilt riders. They are top-heavy and should never be left in the vertical position.

⚠ CAUTION

AVOID SERIOUS PERSONAL INJURY. Up-tilt riders are top-heavy and may fall over. Never leave uptilt rider in vertical position. Use caution when moving.

Do not remove shipping braces until the merchandisers are positioned for installation.

Do not stand or walk on top of merchandiser, because falling off could cause personal injury.

⚠ CAUTION

Do not store items or flammable materials on top of or near these merchandisers. Do not walk on case.

CASE SHIPPING RIDER

Each case is shipped on a rider to protect the factory installed legs, and to make positioning the merchandiser easier. **DO NOT remove the rider until the case has been positioned.** Once the rider is removed, the case must be lifted –NOT PUSHED– to reposition. To remove the rider, remove bolts attaching rider to each leg.

NOTICE

A 3-inch space is required from walls at rear and ends of merchandiser(s) to prevent condensation.

MERCHANDISER LEVELING

Merchandisers must be installed level to ensure proper operation of the refrigeration system and to ensure proper drainage of defrost water. During all steps of setting, joining and leveling merchandisers, close attention to position and operation must be maintained.

NOTE: BEGIN LINEUP LEVELING FROM THE HIGHEST POINT OF THE STORE FLOOR.

Preparation

1. Using store blueprints, measure and mark on floor the exact dimensions/locations of the merchandiser footprint. **A three (3) inch space is required behind each wall merchandiser, or lineup of merchandisers to prevent condensation. A three (3) inch space is also required at ends of merchandiser, or merchandiser lineup to prevent condensation.**

2. Snap a chalk line for the front and rear positions of the base legs.

3. Mark the location of each joint from front to back lines.

4. FLOORS ARE NOT LEVEL!!!

When joining two or more merchandisers, all cases in the lineup must be leveled on the same plane, left to right and front to back. This means that the entire lineup must be brought up to the level of the highest merchandiser in the lineup.

Along the lines previously marked, find the highest point of the floor by:

- Walking the floor and noticing any dips or mounds;
- Using a string level or laser level; and
- Using a transit.

Leveling

Position the first merchandiser at the highest point on the floor. Work outward from that point to create the merchandiser line-up.

Use a 48 inch (1220 mm) or longer level for end-to-end leveling. The discharge nosing of the merchandiser is a good location for the level at the rear of the merchandiser (center of wide island), and the handrail or return nosing is a good location for the level at the front of the merchandiser. For leveling the merchandiser front-to-rear, a 24 inch (610 mm) level should be placed on the flange of the merchandiser end frame. Suggested level locations are shown in the following illustrations on the next page.

Leveling Wall Merchandisers

Level the case by all four corners. Start at the rear by placing the provided shims as needed under each end of the rear base rail. The shims are long enough to allow adjoining wall cases to be leveled with the same shim. **When the rear of the case is level end-to-end, move to the front of the case.** Use an 18 mm open end wrench to screw down the levelers at each front corner so that the front is also level from end-to-end. At this point, check to see if the case is level front-to-rear. If it is not, add shims until the case is level front-to-rear.

The merchandiser should be solidly supported at least every 4 feet (1220 mm). Once the merchandiser is level, if any gaps are present, shims should be inserted under the rear base rail approximately in line with the center front support legs to support the rear of the case. At the front of the case, add shims under each of the center support legs so that they contact the floor and support the front of the merchandiser.

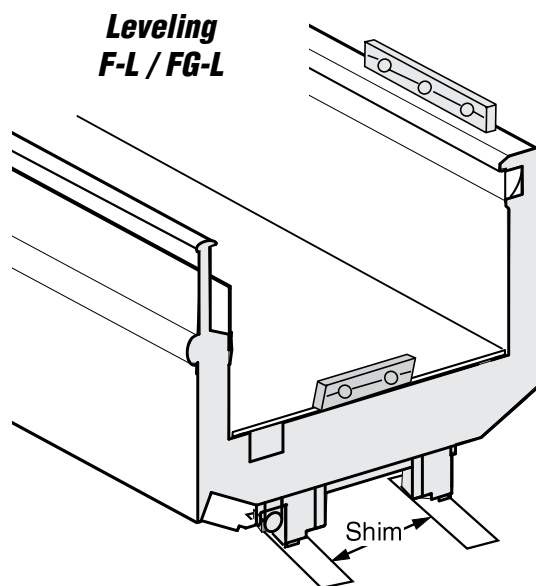

NOTE: Do not place levels on Display Pans or on Racks.

Leveling Narrow, Intermediate, Wide Island or End Merchandisers

Position the first merchandiser at the highest point. Set a long level (4 ft [1220 mm] or more) on top of the discharge air flue. Add shims until the merchandiser is level from end to end and from front to back. Check all 6 legs on 8 ft (2438 mm) merchandisers, or 8 legs on 12 ft (3658 mm) merchandisers.

NOTE: To avoid removing concrete flooring, begin lineup leveling from the highest point of the store floor.

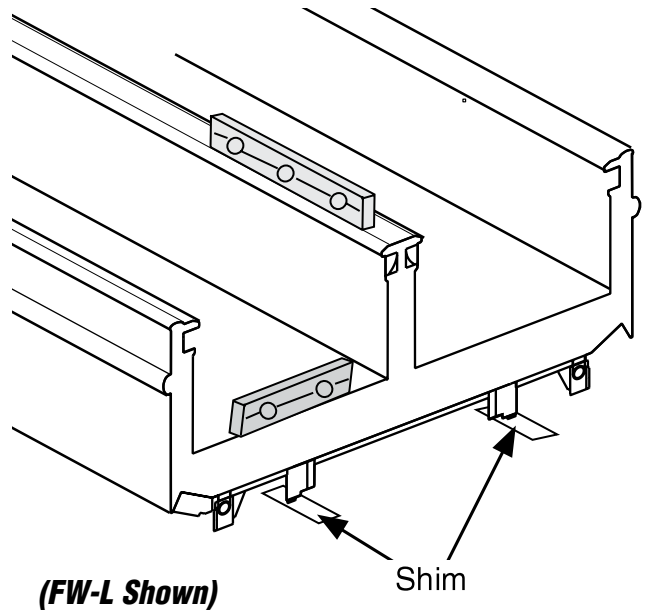

JOINING INSTRUCTIONS

Sectional construction means that two or more merchandisers may be joined in line yielding one long continuous display requiring only one pair of ends.

ALL JOINTS MUST BE AIRTIGHT TO PREVENT FORMATION OF ICE OR CONDENSATION.

Prep Merchandiser

1. Check to be sure that merchandisers are level. Locate Joining Kit and check contents.
2. Remove wire racks and display pan. Before removing interior front and back panels, remove the fasteners holding the retainers for the discharge air louvers. (Lift louvers up and out from the bottom.) Remove any return air flue plex-glass parts. (Lift up on interior panels to remove.) See 1-14 for replacement. **NOTE:** FWE and FWE-G end merchandisers have joining fasteners inserted in the appropriate locations. Remove nuts and washers from outside of end merchandiser before attempting to join.

Apply Gaskets to Right End

1. Apply the 1 5/8 in. (41 mm) gasket around the perimeter of the merchandiser as shown. It must be at the edge. Check to be sure that there are no gaps between gasket and merchandiser.
2. Apply the 1 in. (25 mm) gasket across the end shoe as shown. Each end of the gasket should extend onto the 1 5/8 inch gasket but not over. Check to be sure that there are no gaps between merchandiser and gaskets.
3. On narrow and intermediate islands, wall merchandisers, and cases, apply the 1 in. (25 mm) gasket at the top of the discharge and return air flues as shown. On wide islands, apply the 1 in. (25 mm) gasket at the top of return air flues as shown. Apply the 1 5/8 in. (41 mm) gasket at the top of the discharge (center) flue as shown. **NOTE:** When adding an end merchandiser, apply gaskets to the wide island, not the end merchandiser.

IMPORTANT

- Do not stretch gasket, especially around corners.
- Do not butt gaskets; always overlap them as shown.
- Remove paper backing after gasket has been applied.

• Perimeter gasket is required by NSF.

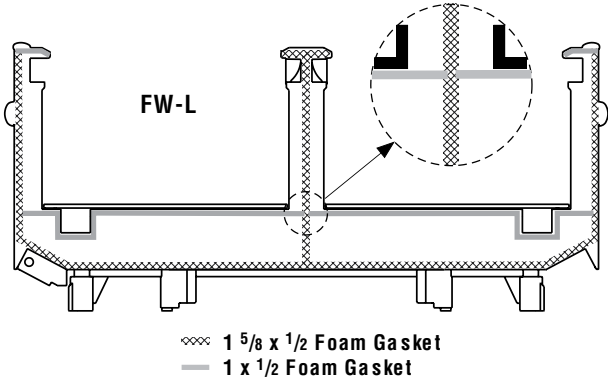
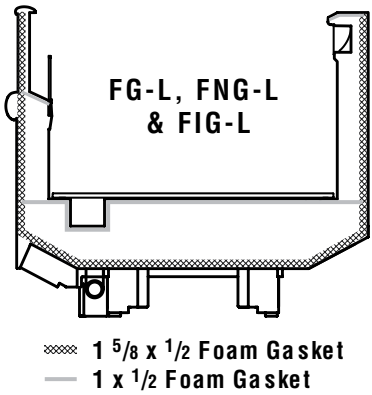
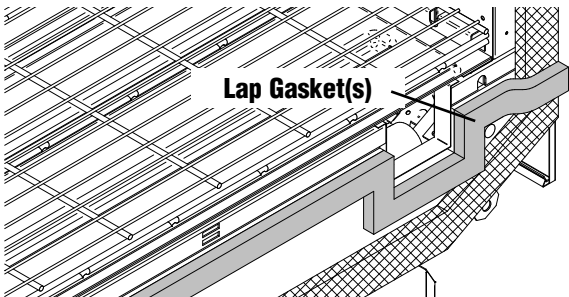

JOINING MERCHANDISERS IN LINE

1. Remove and retain any factory-installed fasteners.
2. *Move merchandisers in lineup as close as possible by pushing or using lever bar (mule).*



Verify alignment of panels, bumper retainer and top rail.



Shim cases to ensure vertical alignment of panels and top rails.

Install fasteners (parent to parent).

3. **Verify upper front panel, front panel, bumper retainer, and top rail alignment *before* joining merchandisers, and shim as necessary. Panels and Top Rail must have equal overhang at each end of merchandiser.**

NOTE: Merchandisers must be leveled before joining. Verify all top rails, panels and bumper retainers of each merchandiser to be joined align vertically before joining.

To correct vertical alignment of top rails and upper front panel, adjust shims as necessary.

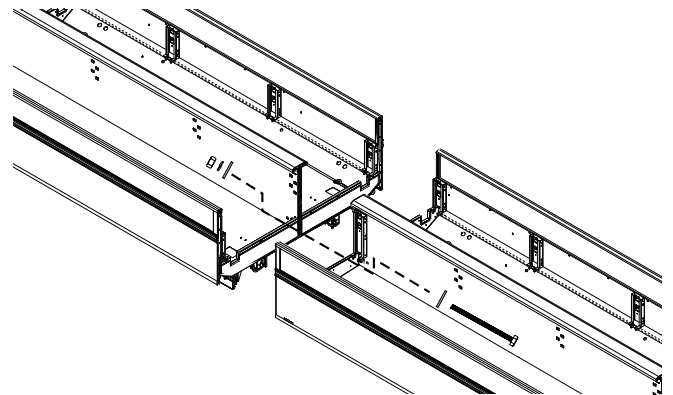

4. Align frame fasteners. **Fastener size and location are detailed on Pages 1-10 and 1-11.** Loosely assemble bolt, washers, lockwasher and nut as shown here.

NOTE: Joining hardware is shown enlarged for clarity.

For glass cases, remove nut retainer clips in one of the case's end frame for each pair of cases joined in the lineup.

NOTE THAT ALIGNMENT ORDER IS DIFFERENT FROM TIGHTENING ORDER!

Do not attempt to draw merchandisers together using nut and bolt.

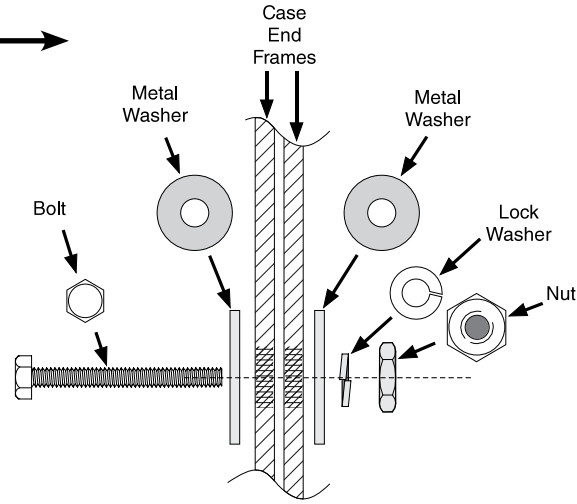

5. Secure H-shaped joining clip between merchandisers at center rail as shown. Lift plastic handrail if necessary.

NOTE: H-shaped joining clip is not used when joining end merchandisers with stainless steel rails.

Bumper retainer design that allows for slight lateral movement for both solid and glass front merchandisers.

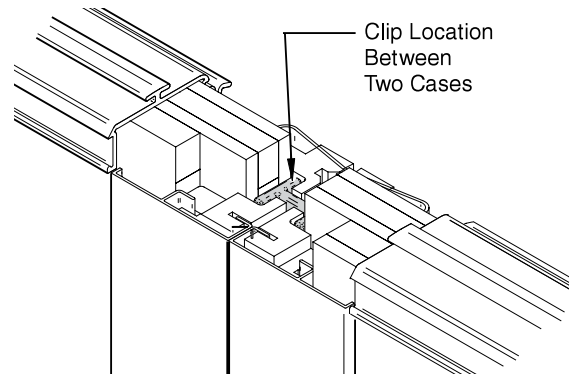

6. Join bumper retainers

Joining brackets are installed in factory. Be sure to loosen joining bracket screws before tightening and joining the bumper brackets.

Tighten the screws of joining brackets after tightening the other screws according to Sequence 6A and 6B for FW cases on Page 1-13, and Sequence 8 and 9 for FI cases as shown on Page 1-13.

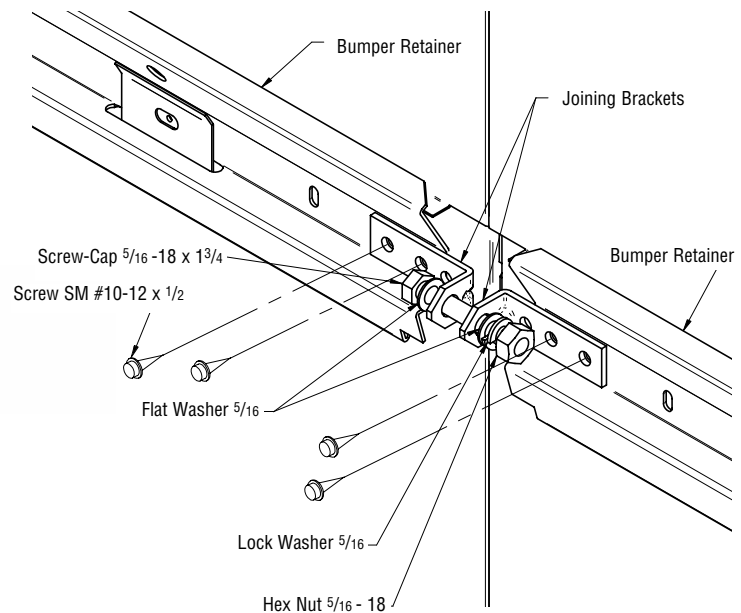

JOINING END MERCHANDISER TO WIDE ISLANDS

NOTE: Merchandisers must be level before joining.

1. Remove nuts and washers from outside of end case.
2. Apply gaskets to wide island.
3. Move end as close to the wide island as possible by using lever bar (mule). Take care not to damage legs.



4. Verify upper front panel, front panel, bumper retainer, and top rail alignment *before* joining cases, and shim cases as necessary.

NOTE: Merchandiser must be leveled before joining. Verify all top rails, panels and bumper retainers of each merchandiser to be joined align vertically before joining.

To correct vertical alignment of top rails and upper front panel, adjust shims as necessary.

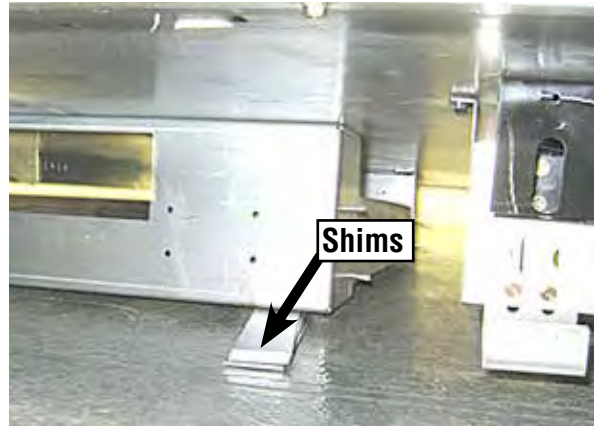

NOTE THAT ALIGNMENT ORDER IS DIFFERENT FROM TIGHTENING ORDER!

Verify alignment of panels, bumper retainer and top rail.



Shim cases to ensure vertical alignment of panels and top rails.

Install fasteners (parent to end).
(Lid removed from end case for clarity.)

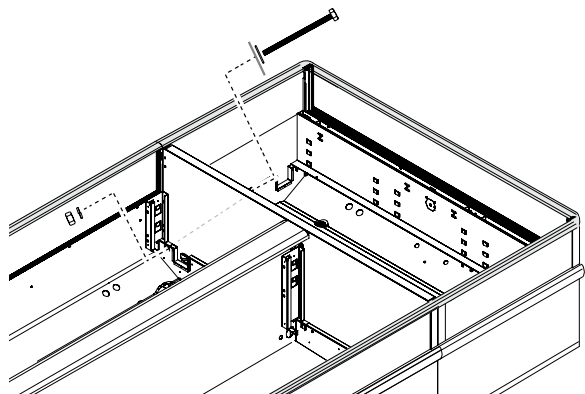

5. Align end case with wide island frame.
Fastener size and location are detailed in pages 1-12 and 1-13. Loosely assemble bolt, washers, lockwasher and nuts as shown here.

NOTE: Joining hardware is shown enlarged for clarity.

NOTE THAT ALIGNMENT ORDER IS DIFFERENT FROM TIGHTENING ORDER!

Do not attempt to draw merchandisers together using nut and bolt.

NOTE: H-Shaped Joining Clip is not used when joining end merchandisers with stainless steel rails.

Bumper retainers allow for slight lateral movement for both solid and glass front merchandisers.

NOTE:

When installing more than one lids frame cassette, a spacer is used on both sides. The spacer is packed out in the trim kit, and is applied using adhesive. This does not apply for FWE-L and FWEG-L. See Section 4 for lids installation.

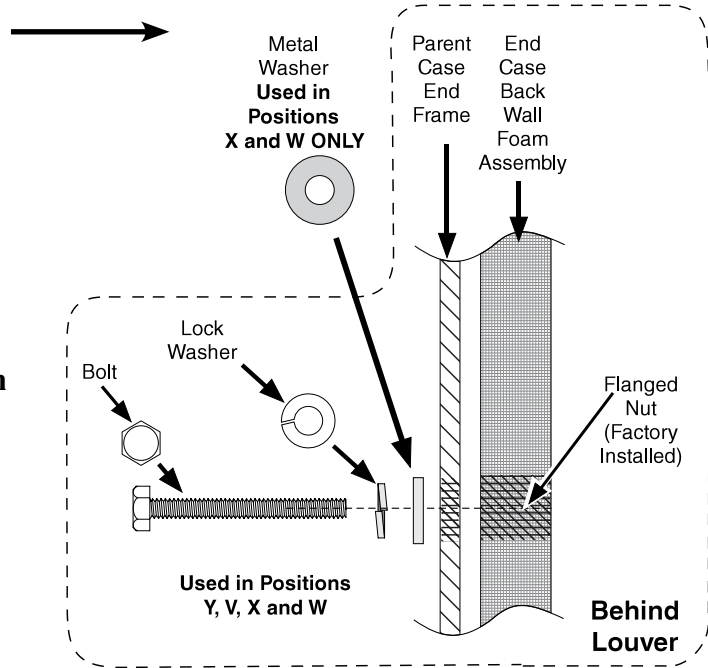

6. Join bumper retainers.

Joining brackets are installed in factory. Be sure to loosen joining bracket screws before tightening and joining the bumper brackets.

Tighten the screws of joining brackets after tightening the other screws according to Sequence 6A and 6B for FW cases on Page 1-13, and Sequence 8 and 9 for FI cases as shown on Page 1-13.

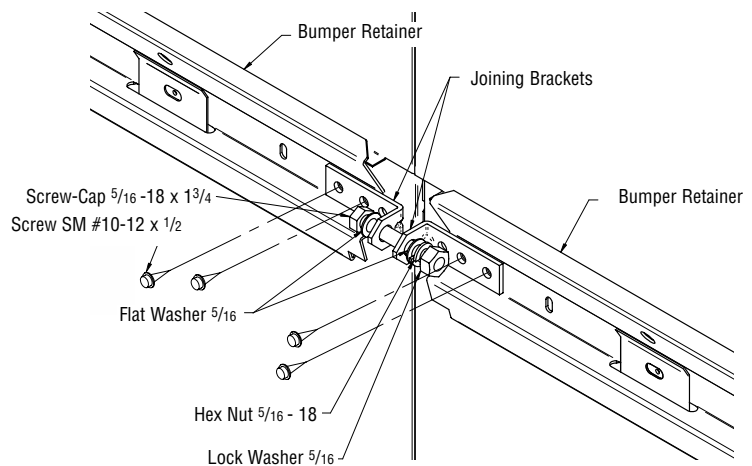

Parent to Parent Installation KEY:

- T — Center Flue End Cap Alignment Pin
- U — 5/16-18 X 1 3/4 in. Hex Head Screw
- V — 5/16-18 X 3 1/2 in. Hex Head Screw
- W — 5/16-18 X 1 3/4 in. Hex Head Screw
- X — 5/16-18 X 4 1/2 in. Tap Bolt
- Y — M6 - 1.0 X 25 mm Hex Head Screw
- Z — Joining Clip

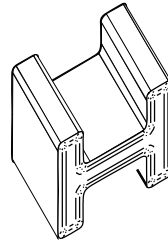

Joining Clip



Use a socket with a U-joint adjustable adapter to more easily tighten fasteners.

FW-L to FW-L

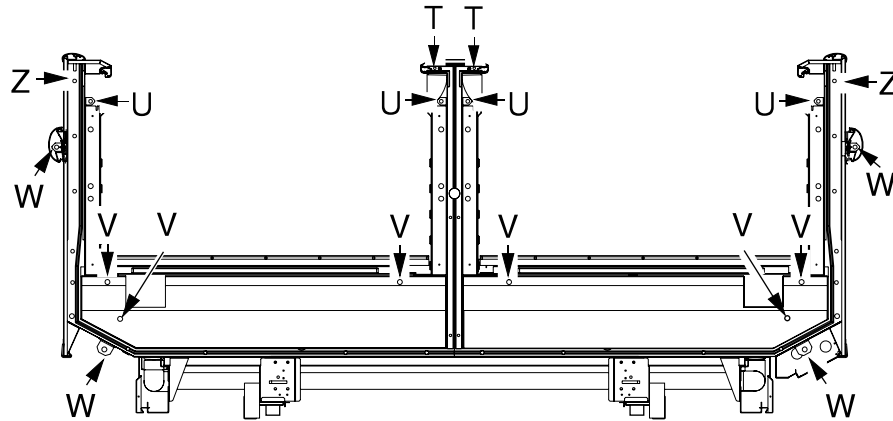

FWG-L to FWG-L

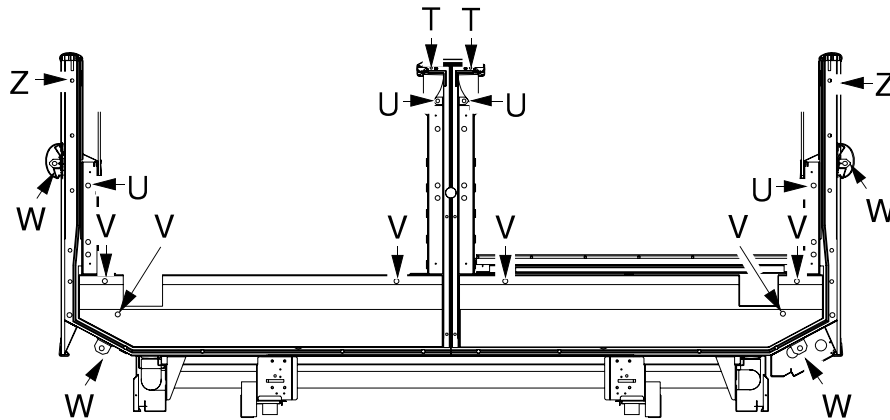

FWGH-L to FWGH-L

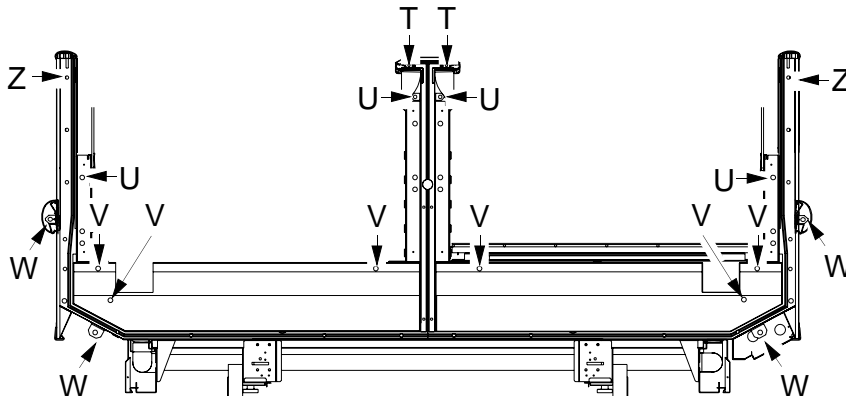

FI to FI

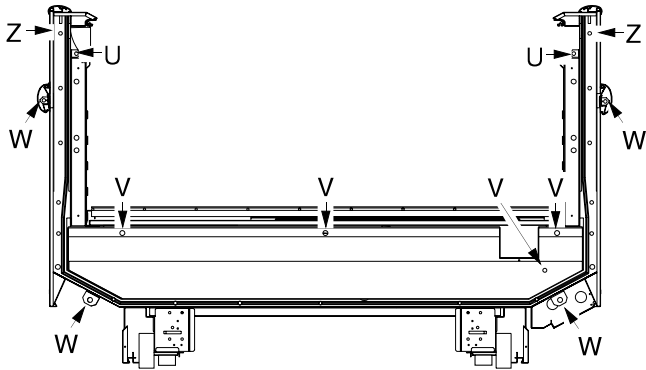
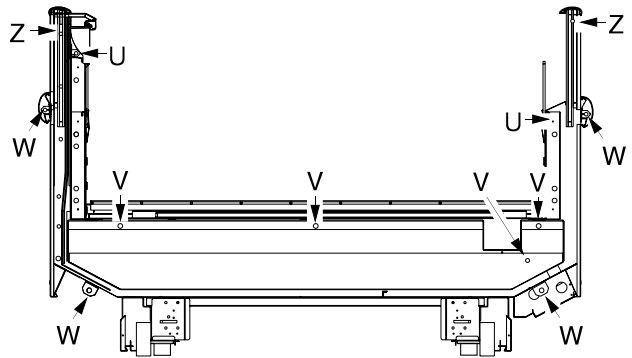
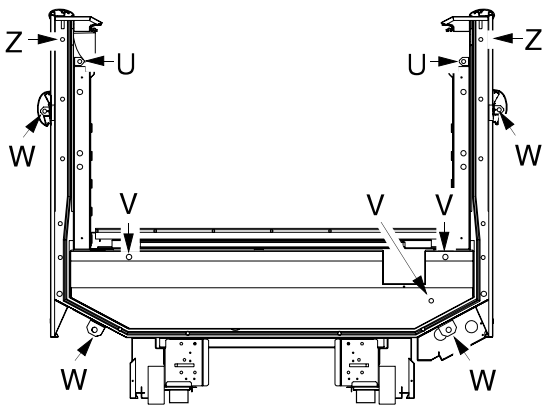

FIG to FIG



FN to FN



FNG to FNG

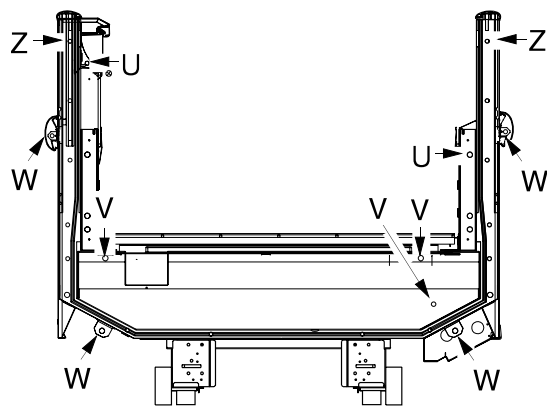

F to F

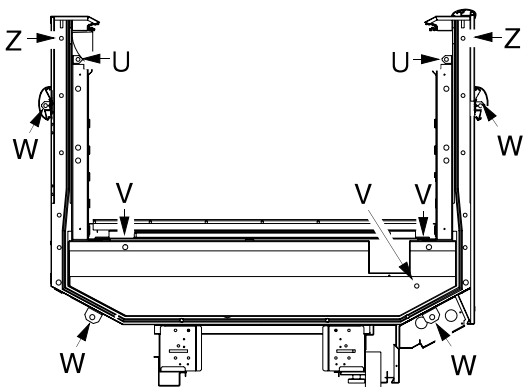

FG to FG

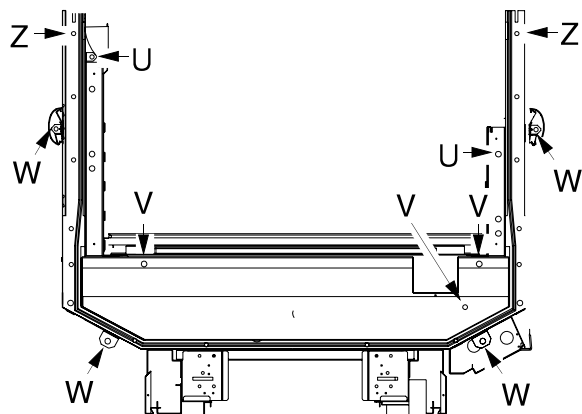

These case may use a prior version of the lids design.
Contact your Hussmann representative for service support.

Parent to End Installation KEY:

- T — Center Flue End Cap Alignment Pin
- U — 5/16-18 X 1 3/4 in. Hex Head Screw
- V — 5/16-18 X 3 1/2 in. Hex Head Screw
- W — 5/16-18 X 1 3/4 in. Hex Head Screw
- X — 5/16-18 X 4 1/2 in. Tap Bolt
- Y — M6 - 1.0 X 25 mm Hex Head Screw
- Z — Joining Clip

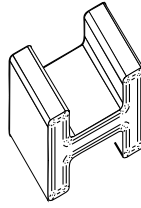

Joining Clip



Use a socket with a U-joint adjustable adapter to more easily tighten fasteners.

FW-L to FWE-L

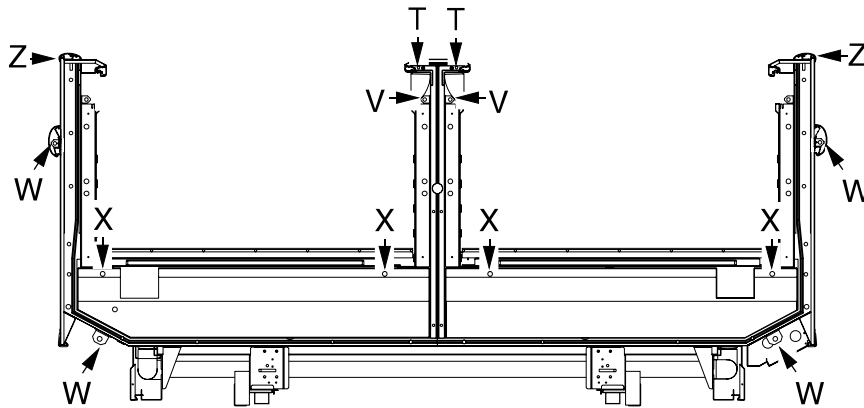

FWG-L to FWEGL

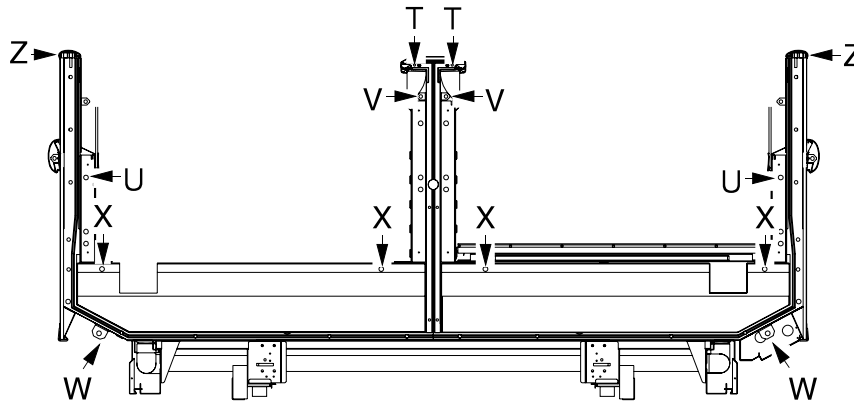

FWGH-L to FWEGL

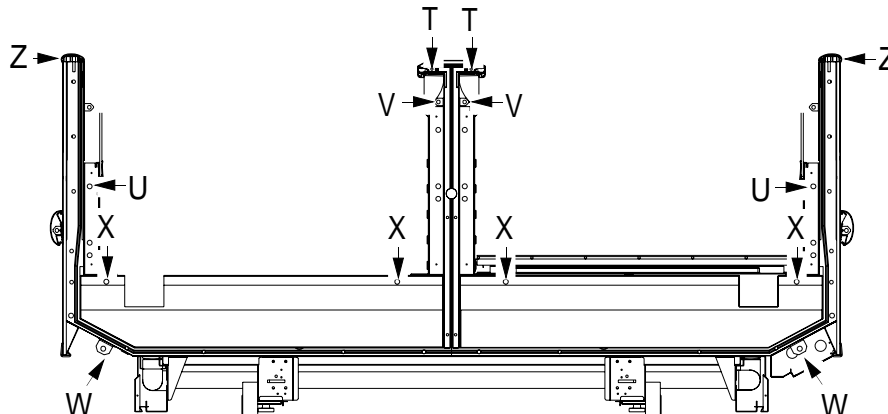

Fasten End Frames

1. Tighten joints in the order shown until gaskets are compressed, and merchandisers join smoothly. Work from the lower front to lower back to upper back. Fasten the upper front last.

When joining End merchandisers to Wide Islands, follow the joining order for the wide island, beginning with 1A and 1B.

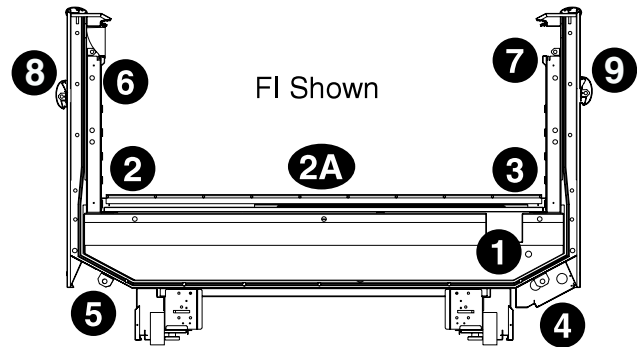

Tighten in Order Shown

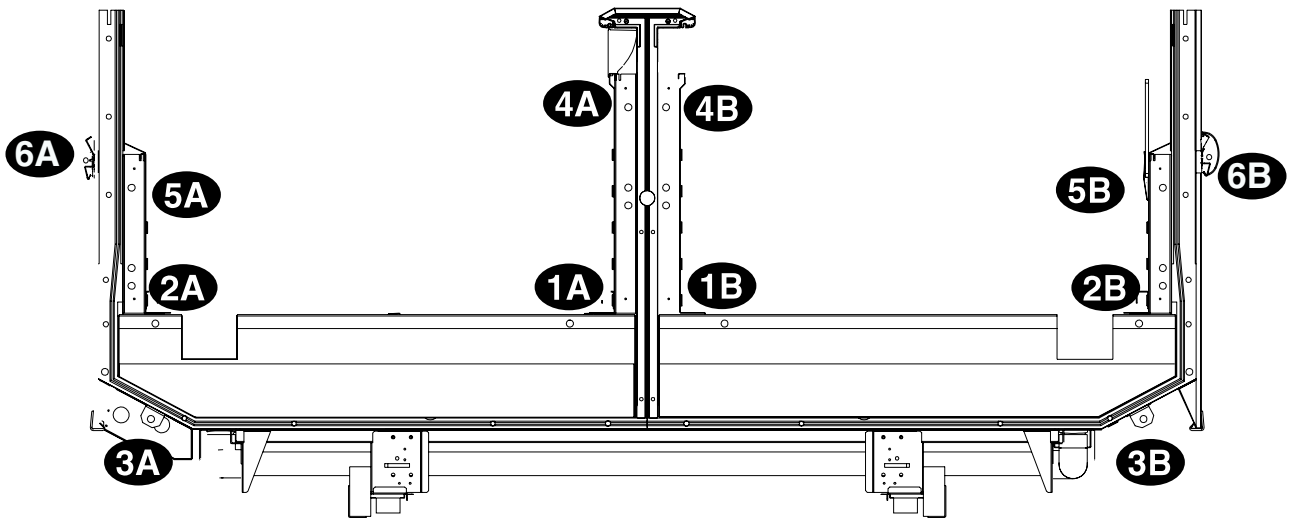

Tighten in Order Shown

Seal Merchandisers

1. Remove wire rack, rack supports and interior panels to apply butyl tape.

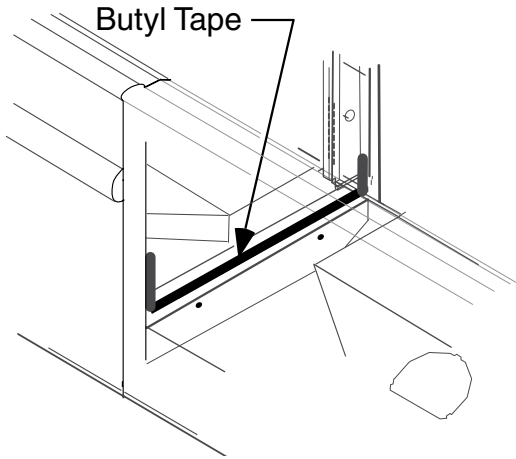

2. Apply butyl tape across the bottom joint. Be sure to extend the tape up the back and front of the merchandiser.

Silicone sealer may be applied around joining bolts on both sides in bottom shoe.

INSTALLING SPLASHGUARD BRACKETS

Position splashguard brackets to the merchandiser and level to the floor. Each bracket has a 1 1/2 in. (38 mm) slot at the rear of the bracket where it attaches to the merchandiser. Tighten screws to secure the brackets.

Important: Install splashguard brackets before installing drip piping.

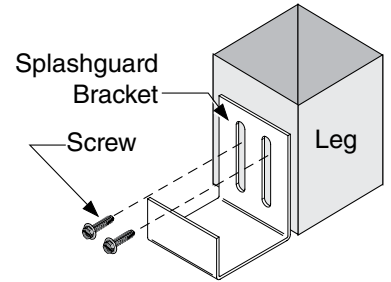

REPLACING INTERIOR PANELS AND DISCHARGE AIR LOUVERS

After case joining is complete and all joining bolts are fastened, re-install the interior front and back panels. Special care needs to be taken when re-installing the discharge air louvers. The flange at the top of the louver must properly fit into the correct position in the extrusion. Incorrect position of the louver can cause the plastic nosing on the anti-sweat heater to become dislodged. See details in Section 6 for correct steps to re-install plastic nosing extrusion.

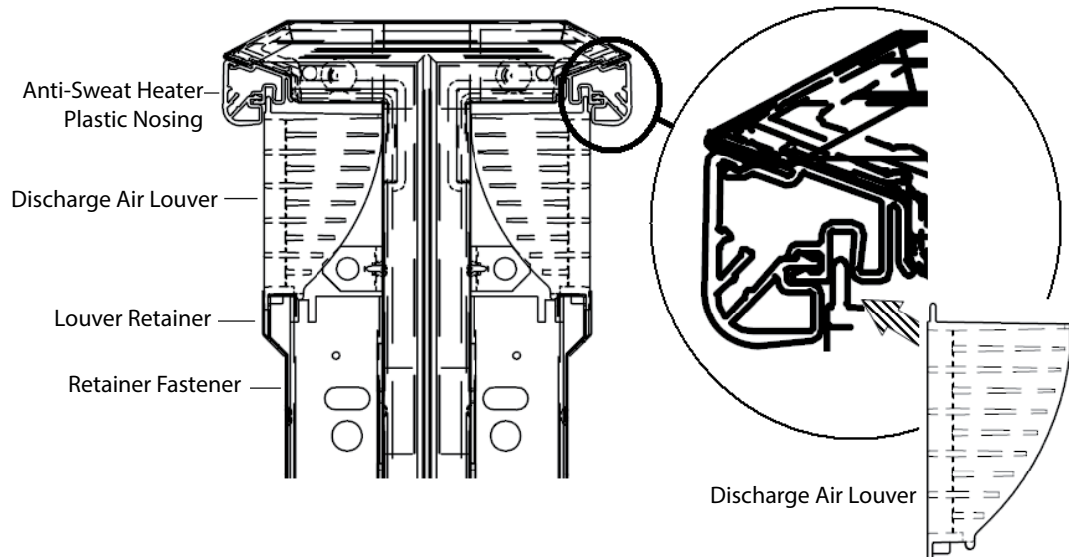

OFFSETTING BUMPERS

Offsetting the bumper helps to disguise the joint locations, giving the lineup a smoother look.

Note: The Excel low temperature case BUMPERS ARE DIRECTIONAL. Look for an arrow inside the bumper.

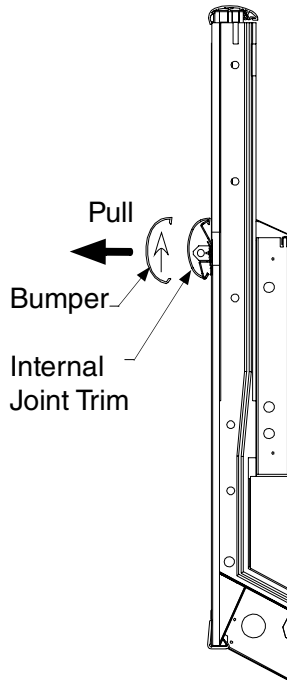

Place the padded pry bar below the bumper as shown below. The tape/padding lessens the chance of damaging the color panel.

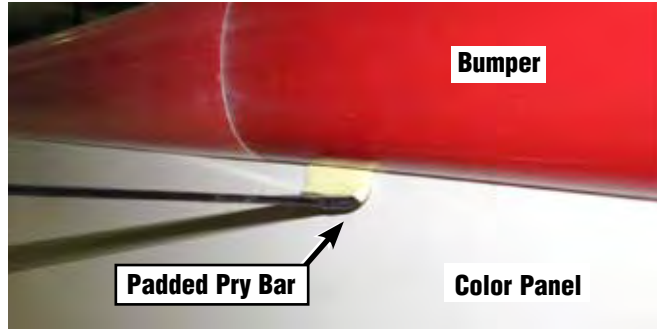

Do not use a screwdriver or other sharp object, which will damage bumper and color panel.



DO NOT USE SHARP OBJECT

Bumper Removal

Although bumpers can usually be removed by hand, a simple tool to remove bumpers can be created by wrapping tape over the claw of a small pry bar as shown here. The pry bar is available at most local hardware stores.



These merchandisers have sheet metal retainers with joining brackets. Bumper retainers may be removed, or adjusted by removing bumper, color panels and bumper retainer screws.

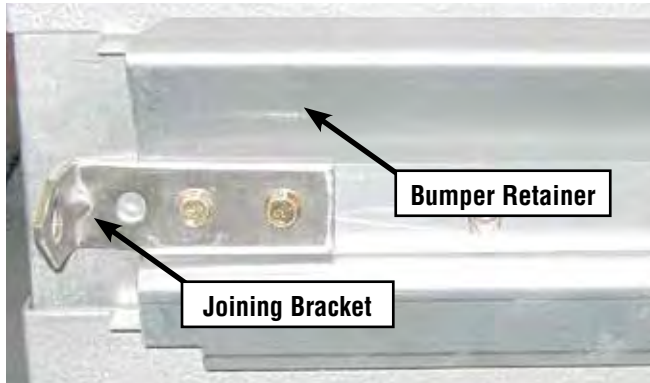

Prying on the long edges is likely to damage the retainer.



Cases with rubber bumper retainers may be removed by lifting the end as shown below.

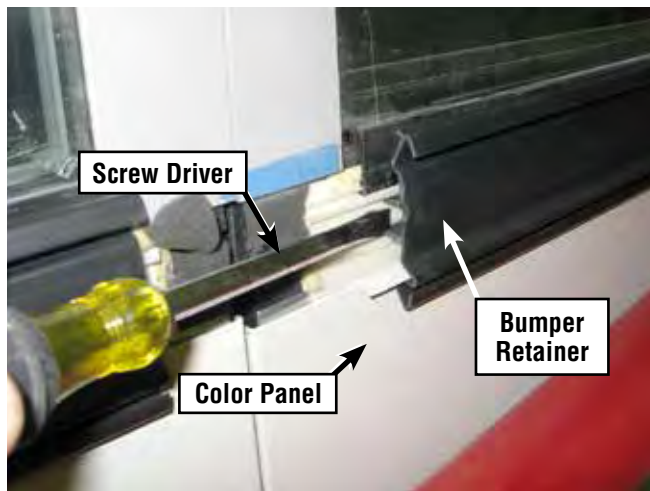

For merchandisers with rubber retainers and glass fronts, replace retainer as shown below using a scrap block of lumber and a rubber mallet. One person should hold the retainer in alignment while another taps it into place.

Offsetting Bumper (for End Merchandisers)

1. Locate starter bumper shipped with the left-end kit.
2. Remove factory installed bumper by pulling bumper away from bumper retainer. Be careful not to lose the internal joint trim on the bumper.
3. Starting at the left end of the lineup, install the bumper starter section first. To install:
 - a. Position internal joint trims so that the first is flush to the left-end panel and the second is centered between the starter bumper and the full-length bumper as shown.
 - b. Install full-length bumpers and internal trims offset across joints. Make sure that no gaps exist between sections. Continue installing the bumpers the length of the lineup.

4. Once all except the last section of bumper have been installed, refrigerate the merchandiser lineup for at least six (6) hours. **The last section of bumper should be kept inside a cooler or refrigerated merchandiser during this time.** This will allow the bumper to contract.
5. Go to the right end of the lineup and tap the bumper to close any gaps.
6. Measure and cut last section of bumper. Use a miter box and fine-tooth saw to cut last bumper to length. Install the last section.
7. Remove protective film from bumper once installation is complete.

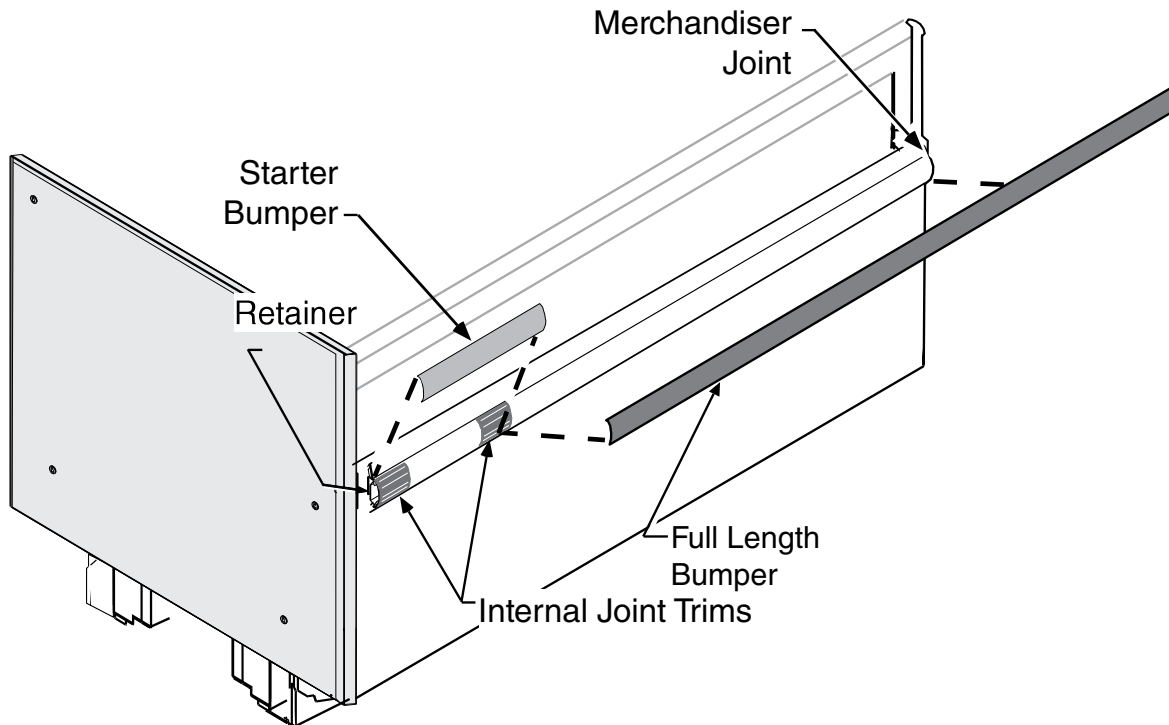
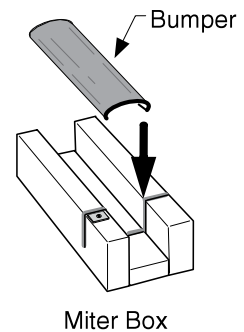

Offsetting Bumper (for Merchandiser Lineup)

1. Locate bumpers for the sides of the lineup. The bumpers are shipped with the merchandisers.
2. Refrigerate the merchandiser lineup for at least six (6) hours. **The offsetting bumpers sections should be kept inside a cooler or refrigerated merchandiser during this time.** This will allow the bumper to contract and provide for a good fit and finish.

3. To install offsetting bumpers:

- a. Remove bumpers from cooler. Measure bumpers and cut to appropriate length. Use a miter box and fine-tooth saw.

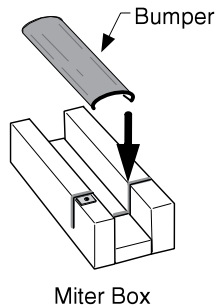

- b. Insert internal joint trims first. Install bumpers offset across joints along the side of the lineup as shown in the illustration below. Joint trim provides stability for the bumpers and lends to a smooth fit and finish.

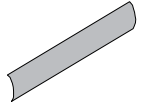

4. Make sure no gaps exist between sections at each end of field cut bumpers.

5. **Verify fit and finish at both sides of corner extrusion.** If bumpers are cut too long, the corner extrusion may bow out resulting in an unattractive finish.

6. Remove protective film from bumper once installation is complete.

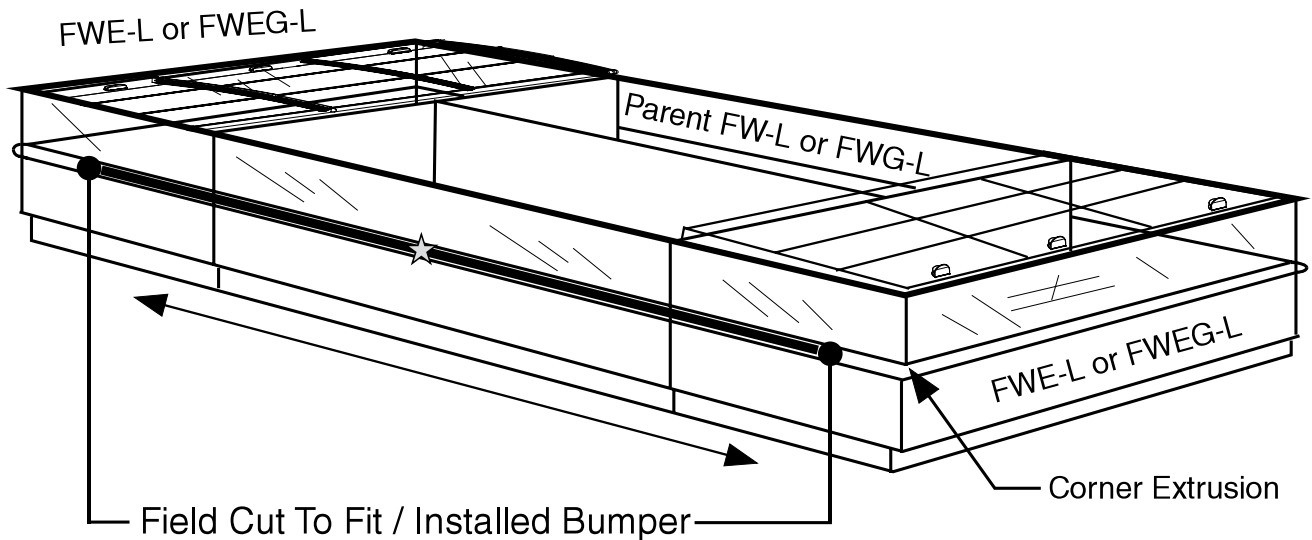

INSTALLING FLUE GLASS — FNG & FIG

The louvers, flue glass, retainer and brackets are shipped loose and must be installed before the lineup can be started up.

1. Apply flue glass Retainer to the top of each section of flue glass.
2. Position the glass in the merchandiser.
3. Slide a Discharge Deflector Bracket into each bend of the and into the flue glass retainer.

INSTALLING FLUE GLASS CLAMP (FWGH & FWEHG)

The flue glass retainer is installed as shown below. Insert supplied bolts (4) through retainer, Bolts fasten into factory-installed nut retainers.

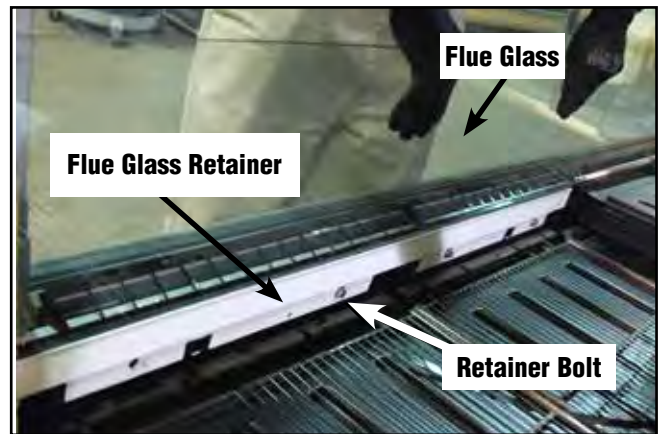
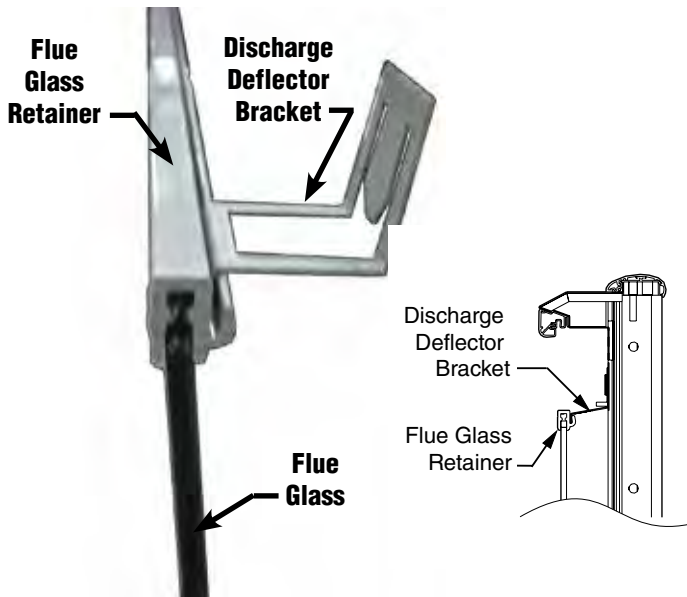

The flue glass is packed inside of the case. Remove the packaging, and slide flue glass securely into top lip of flue glass retainer. Fasten (4) bolts into nut retainers (7f lbs). DO NOT over-tighten bolts.

INSTALLING PARTITIONS

To join same temperature fixtures on different defrost cycles, an acrylic partition kit is required.

To join unlike fixtures, or like fixtures operating at different temperatures, an insulated partition kit is required. It must be installed when setting the lineup. Instructions for installing these partitions are included with the kits.

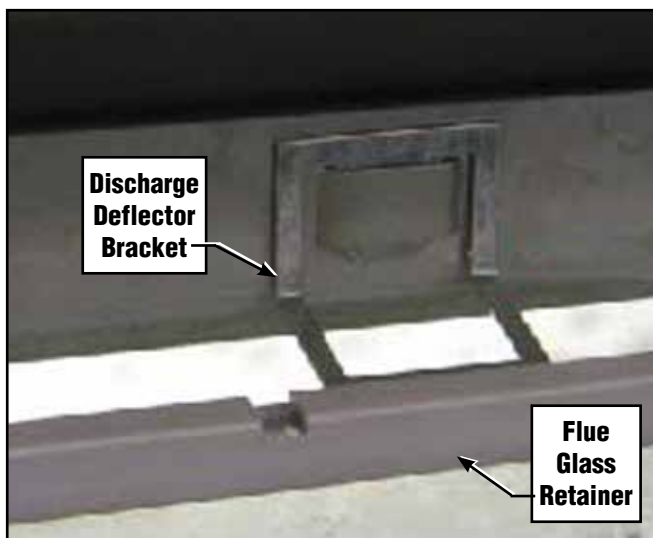

INSTALLING END ASSEMBLIES

End assemblies are normally factory installed. The following information is provided for retrofit or field installation.

1. Prepare Merchandiser

- a. Remove display racks, pans, front rack supports and front air grilles from section of case where end is to be installed.
- b. Remove the interior back panel. No tools required.

2. Apply gaskets to end frame.

3. Fasten End Assembly to Merchandiser

- a. Use Bolt and washer to fasten end assembly to merchandiser in the same way the end merchandiser is fastened.
- b. Tighten in order shown for joining.

4. Seal End to End Frame

Remove front shelf and shelf support bracket. Apply a 1/2 in. bead of Silicone at the back of the case, starting at the first slot. Continue across the bottom and up the front as shown below. Use field-supplied silicone in any gap between front support bracket and end assembly.

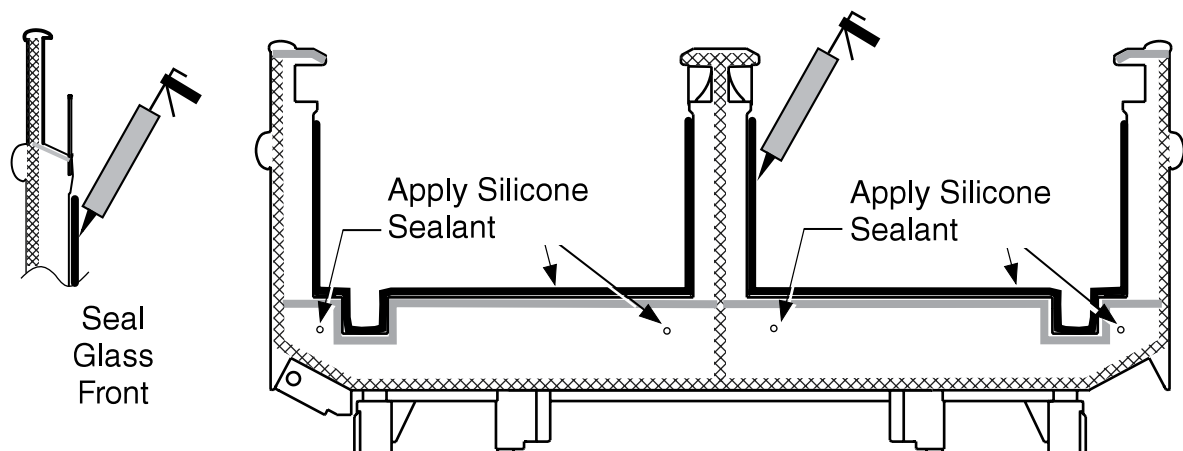

Re-install bumpers as described earlier in this Section.

5. Install End Splashguard Bracket

Insert back of bracket through slot in leg. Use Screws to attach End Splashguard Retainer to end frame.

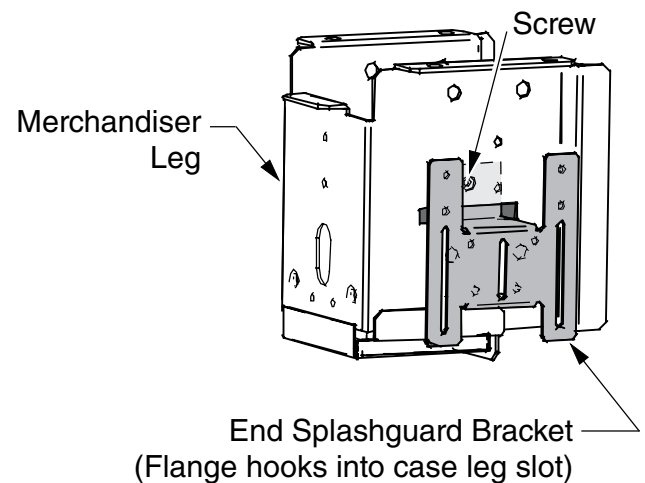

1-22

See Section 4 for installing joining trim and glass gables

NOTES:

REFRIGERATION / ELECTRICAL

REFRIGERANT

The correct type of refrigerant will be stamped on each merchandiser's serial plate. The merchandiser refrigeration piping is leak tested, factory sealed and pressurized. Before making refrigeration hookups, depress the universal line valve to ensure that coils have maintained pressure during shipment. When using high glide refrigerants (e.g., R-407A, R-448A), use the evaporator pressure and subtract the dew point from the coil outlet refrigerant temperature to measure the superheat level.

CAUTION

Refrigerant vapor is hazardous to your health and can cause death.

Avoid breathing refrigerant and lubrication vapor or mist. Exposure may irritate eyes, nose and throat. If accidental system discharge occurs, ventilate work area before resuming service.

Always wear safety goggles and protective gloves when working with refrigerants. Contact with refrigerant may cause injury. Disconnect hoses with extreme caution! All hoses may contain liquid refrigerant under pressure.

Be sure that any room where you are working is thoroughly ventilated, especially if a leak is suspected.

Read all safety information regarding the safe handling of refrigerant and refrigerant oil, including the Material Safety Data Sheet. MSDS sheets can be obtained from your refrigerant supplier.

Refrigeration lines are under pressure and should be depressurized before attempting to make any connections.

REFRIGERANT PIPING

Connection Location

The refrigerant line connections are at the right-hand end of merchandiser (end opposite the main serial plate) beneath the display pans. A sticker marks the location of the connection. The installer must saw a hole to exit the cases.

A refrigeration shroud ships with each case. Before making connections, place the refrigeration shroud over refrigeration piping so that when the shroud is rotated into place, it will be in the upright position. The Figure 2-1 shows the correct orientation.

Be careful not to burn, scorch or overheat the shroud when making connections. Once connections have been made, apply silicone sealant to the bottom of the shroud as shown in Figure 2-2.

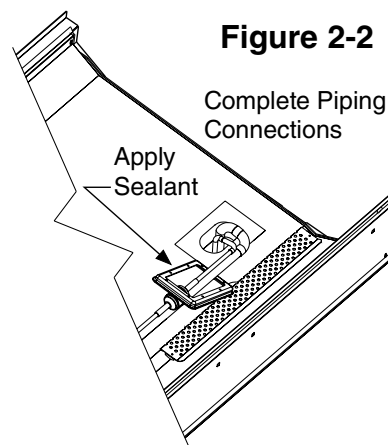
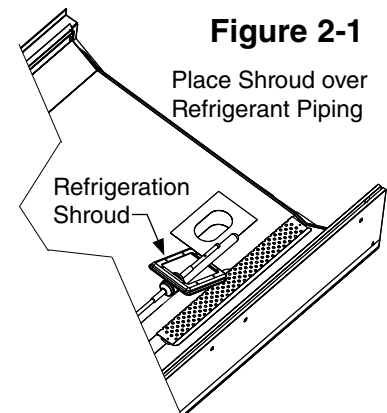

As shown in Figure 2-3, rotate and center the shroud over the refrigeration outlet foam pad, then fasten to the interior liner of the bottom.

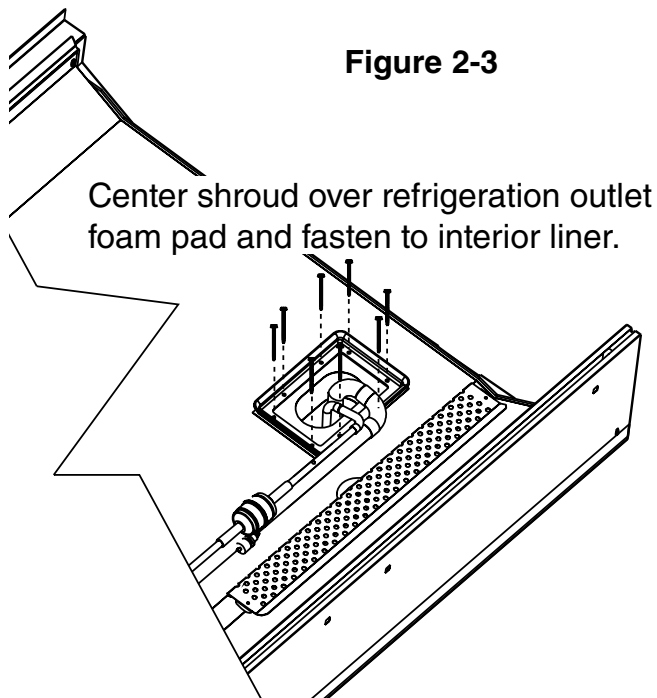

After connections have been made, seal this outlet thoroughly. Seal both the inside and the outside. We recommend using an expanding polyurethane foam insulation. Cover foam with silicone to prevent water from entering foam.

Multiplexing

Piping of merchandisers operating on the same refrigeration system may be run from case to case. **DO NOT RUN REFRIGERANT LINES THROUGH MERCHANDISERS THAT ARE NOT ON THE SAME REFRIGERATION SYSTEM BRANCH** as this may result in poor refrigeration control and compressor failure.

Interconnecting piping inside the merchandiser must be located as shown below for clearance beneath the display pans. Alternately, the interconnecting piping may be run outside the case in the area shown.

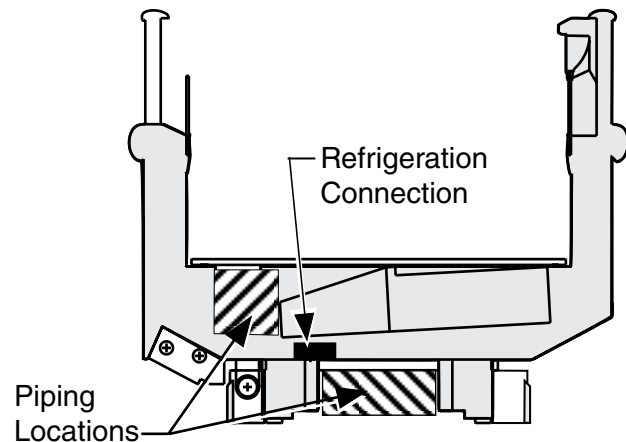

Line Sizing

Refrigerant lines should be sized as shown on the refrigeration legend that is furnished for the store or according to ASHRAE guidelines.

Note: If Koolgas defrost is used, the liquid line will need to be increased two sizes larger inside the merchandiser area. This is necessary to ensure even liquid drainage from all evaporators during defrost.

Oil Traps

P-traps (oil traps) must be installed at the base of all suction line vertical risers.

Pressure Drop

Pressure drop can rob the system of capacity. To keep the pressure drop to a minimum, keep the refrigerant line run as short as possible using a minimum number of elbows. Where elbows are required, USE LONG RADIUS ELBOWS ONLY.

INSULATION

With GAS Defrost

The suction and liquid lines should NOT contact each other and should be insulated separately for a minimum of 30 ft (9144 mm) from the merchandiser.

With OTHER Than Gas Defrost

The suction and liquid lines should be clamped or taped together and insulated for a minimum of 30 ft (9144 mm) from the merchandiser.

With EITHER of Above

Additional insulation for the balance of the liquid and suction lines is recommended wherever condensation drippage is objectionable or the lines are exposed to ambient conditions.

ATTENTION:
 The following information is applicable only for piping Hussmann merchandisers to Hussmann refrigeration equipment.

BRANCH LINE PIPING

Suction Line – All Defrosts

- Pitch in direction of flow.
- May be reduced by one size at one third of merchandiser run load and again after the second third. Do NOT reduce below evaporator connection size.
- Suction returns from evaporators enter at the top of the branch line.

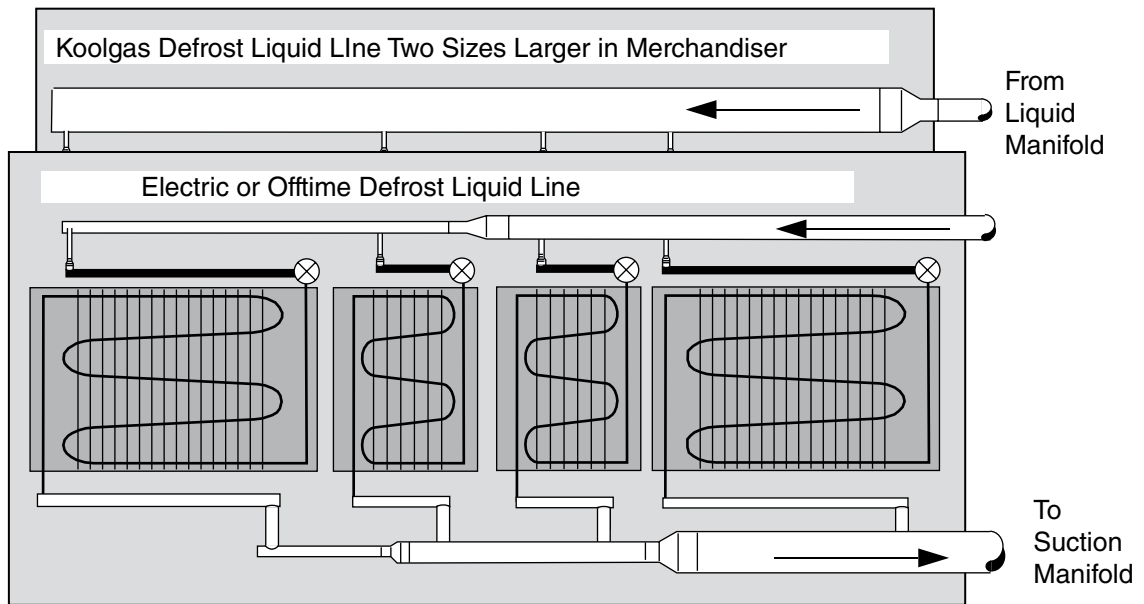

Liquid Line – Off-time and Electric Defrost

- May be reduced by one size after one half the merchandiser load run. Do not reduce below evaporator connection size.
- Take-offs to evaporators exit the bottom of the liquid line. Provide an expansion loop for each evaporator take-off (minimum 3 in. (76 mm) diameter).

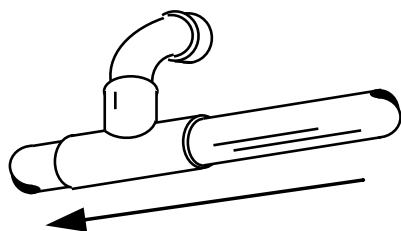

Suction Line Return

Liquid Line – Koolgas Defrost

- Maximum of 6 evaporators per Branch System.
- Increase the liquid line size inside the case by two sizes over the branch size.

| Branch Size | In Merchandiser Size |
|-------------|----------------------|
| 1/2 | 7/8 |
| 5/8 | 1 1/8 |
| 7/8 | 1 3/8 |
| 1 1/8 | 1 5/8 |
| 1 3/8 | 2 1/8 |

- Take-offs to evaporators exit the bottom of the liquid line. Provide an expansion loop for each evaporator take-off (minimum 3 in. (76 mm) diameter).

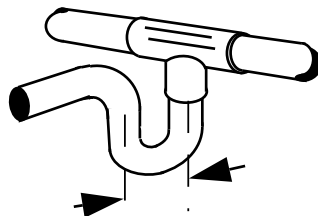

3-In. Loop (76 mm)
Liquid Line Take Off

FRONT TO REAR AND/OR END INTERCONNECTS

The wide island merchandisers are factory equipped with separate piping and air systems for each compartment, and are thus all capable of twin-temperature operation. This is a standard feature.

If the wide island merchandiser is to be run at a single temperature, factory installed piping interconnect kits are available.

NOTE:

A *Dual Temperature Kit* adds components to allow a low temperature merchandiser to operate at medium temperatures, and switch between low and medium temperature operating conditions.

Twin Temp is used on low temperature wide island cases only and is the standard configuration. Twin temp means each side of the island operates separately; thus one side might be set for ice cream conditions while the other side could be set for frozen food or ice cream.

Only when both sides of a wide island lineup will always be used for the same operating conditions, should an interconnect piping kit be considered. Interconnect piping kits cannot be used with dual temperature kits. Contact Hussmann for further information.

REFRIGERATION THERMOSTAT

The refrigeration thermostat body is located in the electrical wireway. The bulb, when factory installed, is located in the discharge flue. Wide Island models will have two thermostats – one on each side of the merchandiser.

DEFROST TERMINATION THERMOSTAT

The standard disc type defrost termination thermostat is not adjustable. This thermostat is clamped to the coil inlet tube.

CDA SENSOR (OPTIONAL)

Factory installed optional CDA sensor is located where the thermostat bulb would normally be located. Its leads will be routed through the electrical wireway and to the rack control panel. Leads are tagged in the wireway. Wide Island models will have two sensors — one on each side of the merchandiser.

MERCHANDISER ELECTRICAL DATA

Technical data sheets are included with this manual. The data sheets provide merchandiser electrical data, electrical schematics, parts lists and performance data. Refer to the technical data sheets and merchandiser serial plate for electrical information.

FIELD WIRING

Field wiring must be sized for component amperes stamped on the serial plate. Actual ampere draw may be less than specified. Field wiring from the refrigeration control panel to the merchandisers is required for defrost termination thermostats and for optional refrigeration thermostats. When multiple merchandisers are on the same defrost circuit, the defrost termination thermostats are wired in series.

ALWAYS CHECK THE SERIAL PLATE FOR COMPONENT AMPERES.

ELECTRICAL CONNECTIONS

All wiring must be in compliance with NEC and local codes. All electrical connections are to be made in the electrical wireway or *Handy Box*.

IDENTIFICATION OF WIRING

Leads for all electrical circuits are identified by colored plastic bands. These bands correspond to the *color code sticker* (shown below) located inside the merchandiser’s wireway cover.

The defrost heaters, defrost termination thermostats and refrigeration thermostats on the wide island models are tagged with identification as being either front or rear merchandiser display section defrost and refrigeration controls.

WIRING COLOR CODE

Leads for all electrical circuits are identified by a colored plastic band: neutral wire for each circuit has either White insulation or a White plastic sleeve in addition to the color band.

| | | |
|-----------------------|--------------------------------------|-------------------------------|
| PINK | REFRIG. THERMOSTAT LOW TEMP. | ORANGE OR |
| LIGHT BLUE.... | REFRIG. THERMOSTAT NORM TEMP. | TAN.....LIGHTS |
| DARK BLUE.... | DEFROST TERM. THERMOSTAT | MAROON.....RECEPTACLES |
| PURPLE | CONDENSATE HEATERS | YELLOW |
| BROWN | FAN MOTORS | DEFROST HEATERS 120V |
| GREEN* | GROUND | RED |
| | | DEFROST HEATERS 208V |

***EITHER COLORED SLEEVE OR COLORED INSULATION**

**ELECTRICIAN NOTE: Use copper conductor wire only.
CASE MUST BE GROUNDED**

DRIP PIPING AND SPLASHGUARDS

WASTE OUTLET AND WATER SEAL

Each merchandiser has two waste outlets. The waste outlets are located in front of the fan plenum 12 inches (305 mm) from either end of the merchandiser.

Depending on the model, tees with clean-outs, or elbows, are supplied for each merchandiser. One water seal is supplied for each merchandiser. The water seal must be installed with the waste outlets to prevent air leakage and insect entrance into the merchandiser.

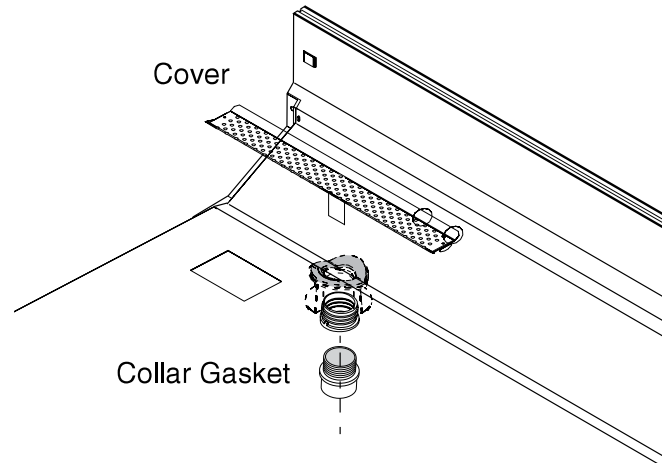

Items Factory Installed for Excel Waste Outlet on Each End of Case

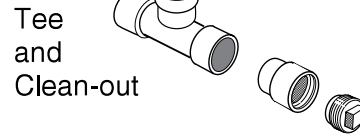
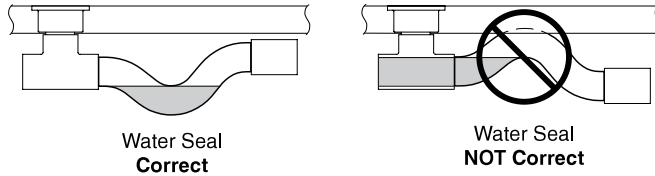

Factory Furnished Items To Be Installed

⚠ CAUTION

Splashguard brackets MUST be installed before piping merchandiser.

INSTALLING DRIP PIPING

Poorly or improperly installed drip pipes can seriously interfere with the merchandiser's operation and result in costly maintenance and product losses.

Optional drip pipe arrangements are shown on the next page. Assemble the components using PVC specific threaded pipe sealer according to the manufacturer's direction.





It is the installing contractor's responsibility to consult local agencies for local code requirements.

Please follow the recommendations listed below when installing drip pipes to ensure proper installation.

1. Never use drip piping smaller than the nominal diameter of the pipe or water seal supplied with the merchandiser.
2. When connecting drip piping, the *water seal* must be used as part of the drip piping to prevent air leakage or insect entrance. Never use two water seals in series in any one drip pipe. **DOUBLE WATER SEALS IN SERIES WILL CAUSE AN AIR LOCK AND PREVENT DRAINING.**
3. Pitch the drip piping in the direction of flow. **There should be a minimum pitch of 1/4 in. per ft (20 mm per 1 m).**

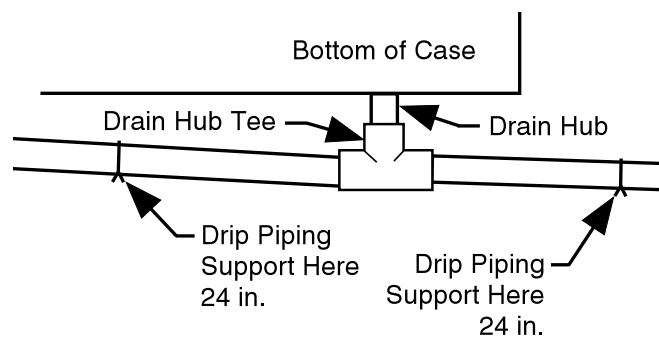
4. Avoid long runs of drip piping. Long runs make it impossible to provide the pitch necessary for good drainage.
5. Ensure that drip piping is supported to relieve any stress on drip pipe connectors and drain hub.
 - a. Drip piping **MUST** be supported 24 inches from drain hub tee.



6. Provide a suitable air break between flood rim of the floor drain and outlet of drip pipe. To meet code requirements, it may be necessary to install a field-supplied drip pipe reducer. An alternative is to cut the last section of drip pipe at an angle.
 

7. Prevent drip pipes from freezing:
 - a. Do NOT install drip pipes in contact with uninsulated suction lines. Suction lines should be installed with a nonabsorbent insulation material.
 - b. Where drip pipes are located in dead air spaces, such as between merchandisers or between a merchandiser and a store wall, provide means to prevent freezing.

DRIP PIPING LINEUP ARRANGEMENTS

The following illustrations below show typical arrangements for installing drip pipes for a lineup of merchandisers. Illustrations are for reference only. Piping may vary with location and access to hub drain(s). Each merchandiser waste outlet must be individually piped to a hub drain if 1/4 in. drip piping pitch cannot be maintained.

NOTE: No more than two merchandisers are to be piped per water seal. Do not install water seal between two merchandiser waste outlets that are piped together. **(Double water seals in series will cause an air lock and prevent drainage.)**

Optional Excel Drip Piping Arrangements

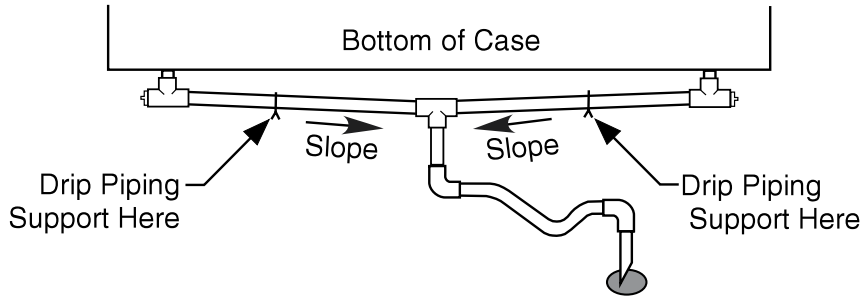

It is the installing contractor's responsibility to provide suitable drainage.

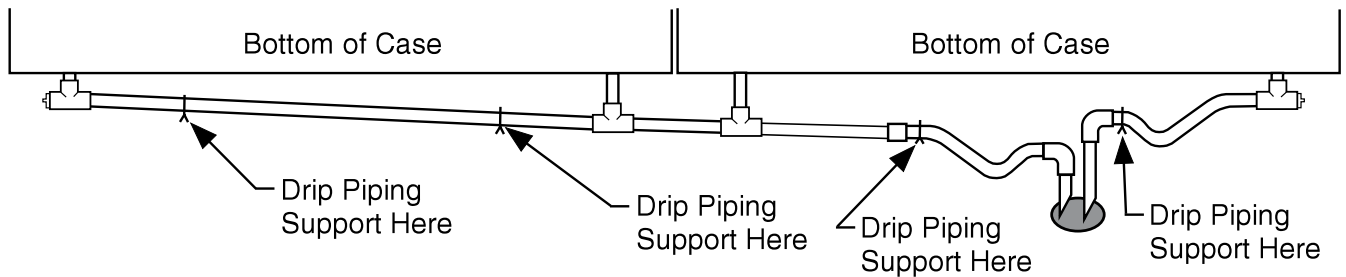

One Water Seal per Run of Drip Pipe
Always Slope Toward Floor Drain

INSTALLING SPLASHGUARDS

The splashguard is shipped inside each merchandiser. **AFTER** merchandisers have been leveled and joined, and all drip piping, electrical and refrigeration work has been completed, install the splashguard. End splashguards are addressed on the next page.

To Install Splashguards:

1. Check to be sure that all splashguard brackets are level with the floor.
2. Position top of splashguard with the top angled in as shown in the illustration. Align the slots in the upper edge of the splashguard with the tabs extending downward behind the splashguard cover.
3. Engage the slots over the tabs and raise the splashguard while pushing the bottom in.
4. Align the tabs on the splashguard brackets with the slots in the bottom edge of the splashguard. Engage the tabs in the slots and drop the splashguard into place.

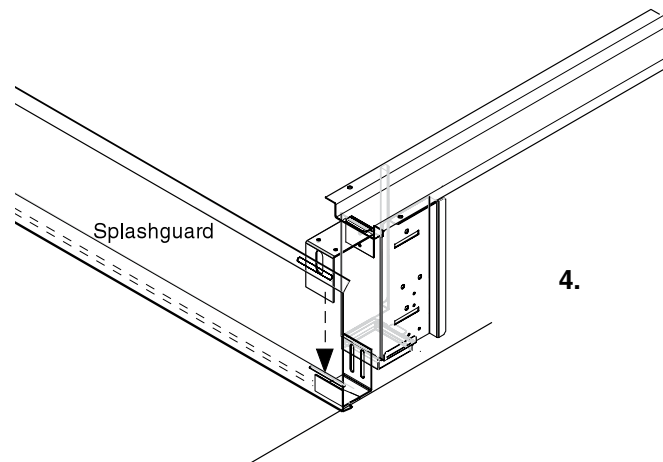
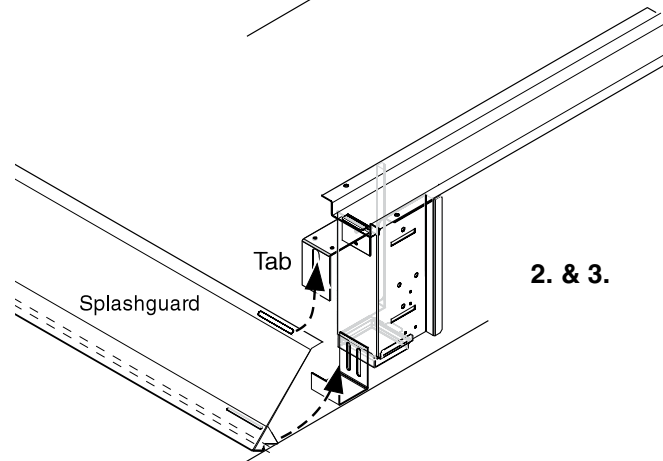
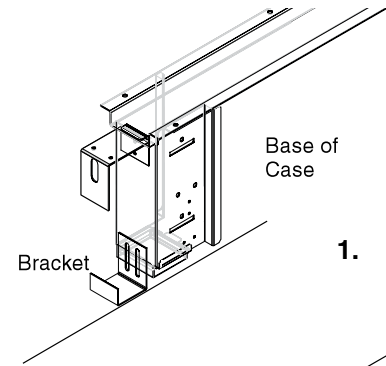

To install the cove trim to the splashguard:

1. Remove all dirt, wax and grease from the area of the splashguard where adhesion will be necessary to ensure a secure installation.
2. Apply a good contact cement to the cove trim and allow proper drying time according to the directions supplied with the cement.
3. Install the trim to the splashguard so that it is lying flush with the floor. **DO NOT SEAL THE TRIM TO THE FLOOR.**
4. **If required by local health codes** the Cove Trim may be sealed to the floor, using a silicone type sealer. Sealant must be removed and replaced when servicing.

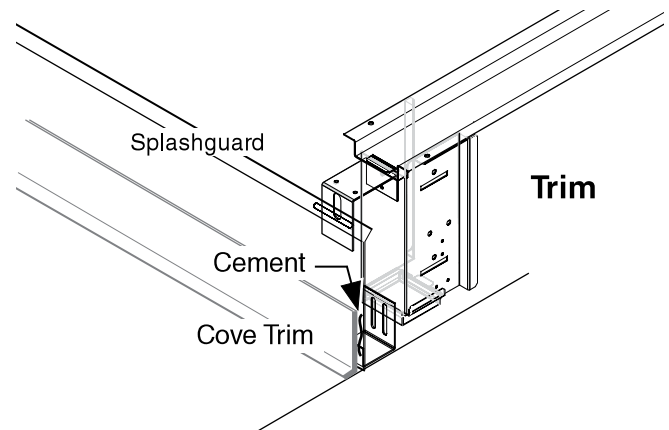

Installing Splashguard on End and End Case

An end splashguard ships with each end assembly. End case splashguards ship with the case. Install end splashguards after main splashguards.

1. Check to be sure that all splashguard brackets are level with the floor.
2. Position top of splashguard with the top angled in, behind the lower panel bracket.
3. Raise the splashguard enough to align the tabs on the splashguard brackets with the slots in the bottom edge of the splashguard. Engage the tabs in the slots and drop the splashguard into place.

Cove trim may be added in the same way as for the main splashguards.

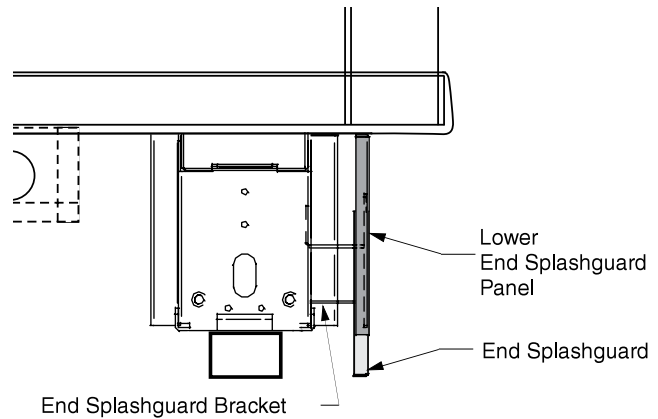
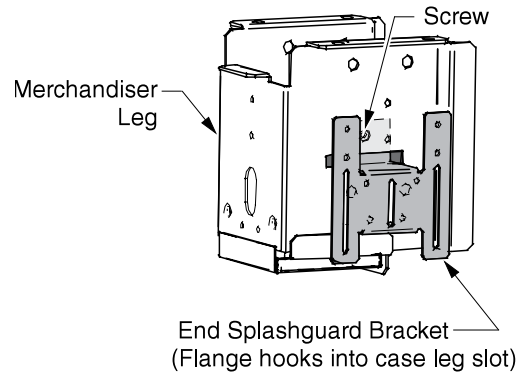

End Splashguard Installed

INSTALLING TRIM AND GLASS GABLES

When installing more than one frame, a spacer is used on both sides. The spacer is packed out in the trim kit and is applied using adhesive. This does not apply for FWE-L and FWEG-L. Solid and glass cases have different retainers.

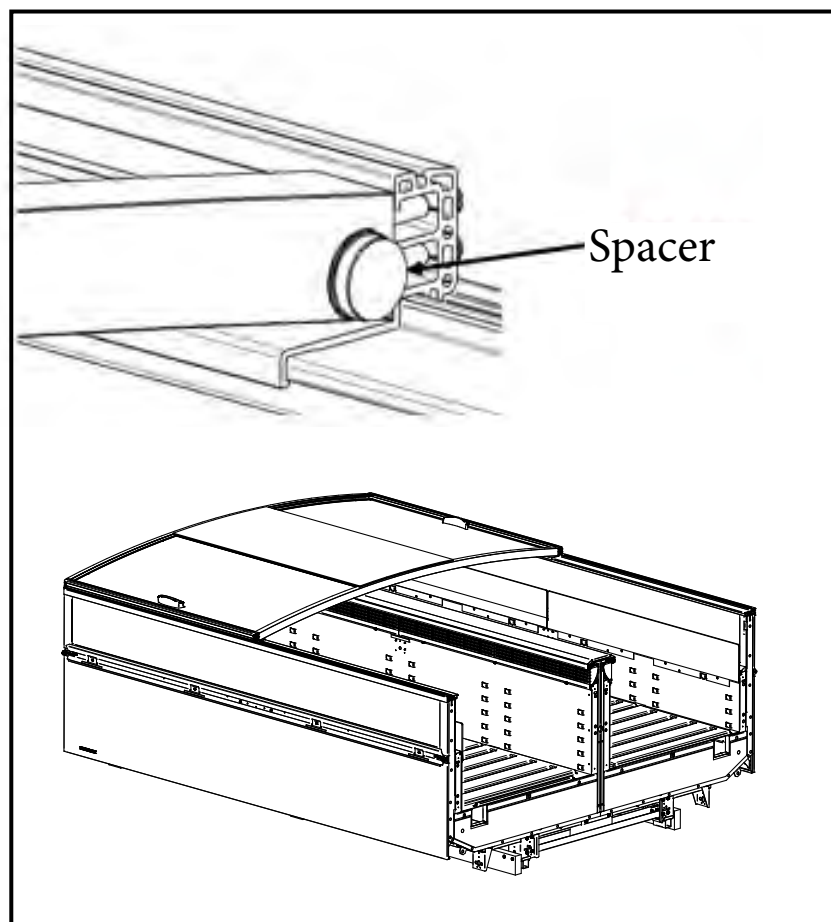

CAUTION

AVOID SERIOUS PERSONAL INJURY. Use caution when handling glass. Always wear protective eye wear and gloves when handling glass. Wet or damp glass may be slippery.

4-2 INSTALLING TRIM & GLASS GABLES

Décor trims are installed on the cases for transit. Trim will need to be removed in a line up, and reinstalled with the starter trim (same as with case bumpers).

1. Install the decor profiles as shown below. Note a starter decor piece (about 2 ½ ft long) is used to disguise case joints in the lineup.

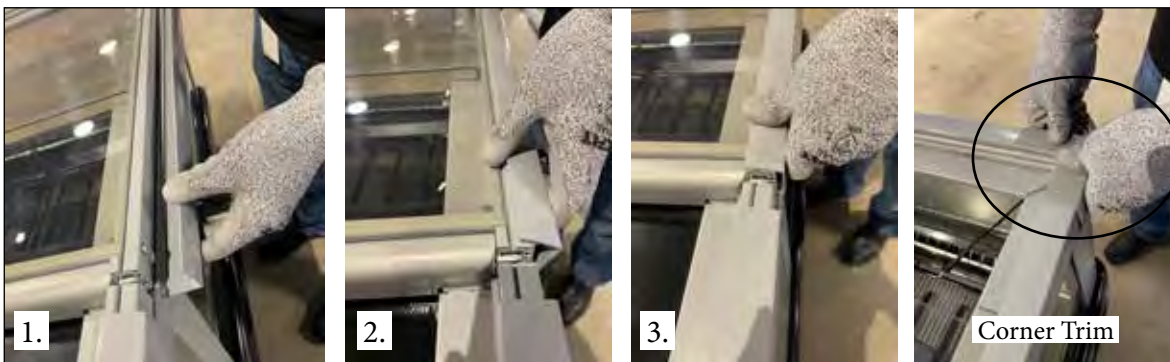
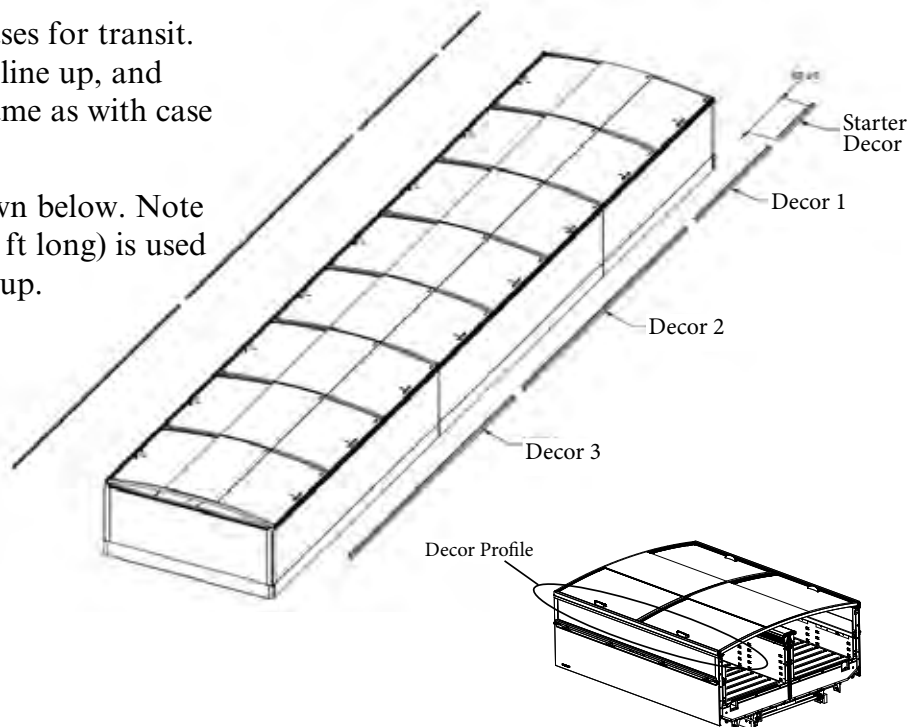
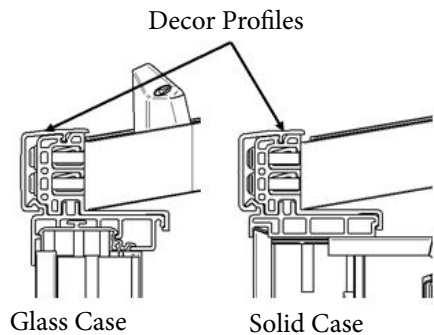

2. Gap profiles are installed between frame cassettes and between cassettes and ends. Before installing, make sure the gap profile is cleaned and the cassettes are cleaned and aligned.

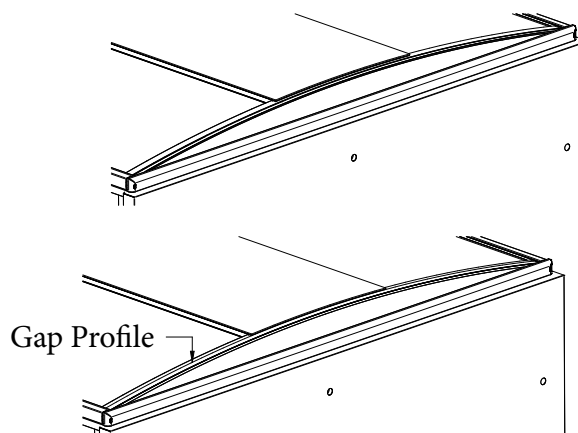
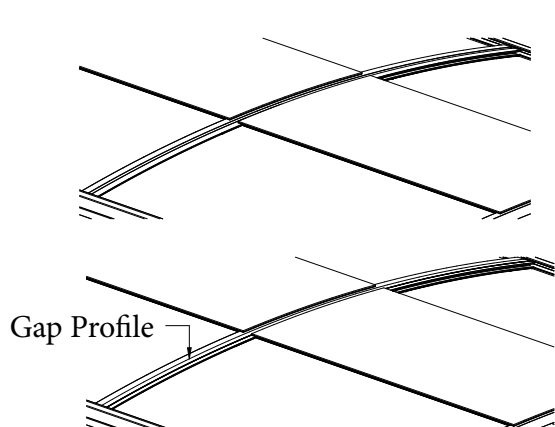

ATTACHING GABLES (FLAT CASE ENDS)

1. Glass gables are installed to close the space at the ends of the case for the lids. Clean all pieces before starting the installation. Seat the filler on the flat end, aligning it on both sides, and fix it in place with screws. (Remove the paper liner on the adhesive tape to set it in place correctly.)

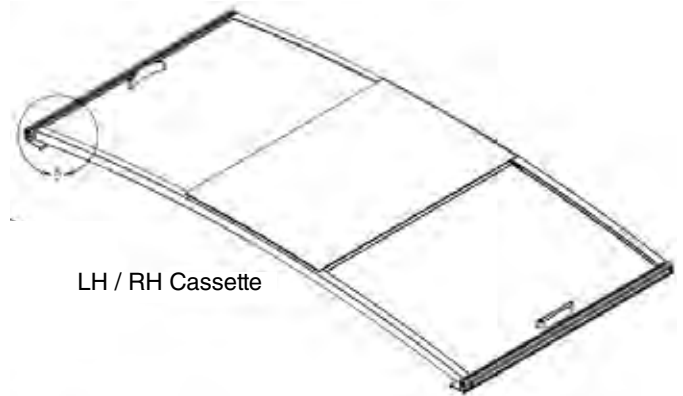
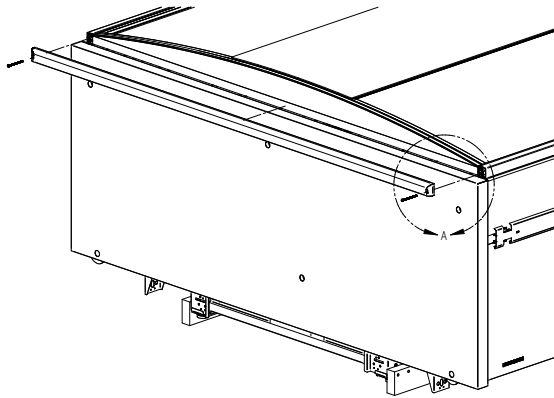

LH / RH Cassette

IMPORTANT!

Set the filler on top of the flat end. Use adhesive tape along the filler trim piece. Align it on both sides with the holes as shown, then screw the filler to the cassette. Make sure there is no gap between filler, flat end and cassette after it is installed.

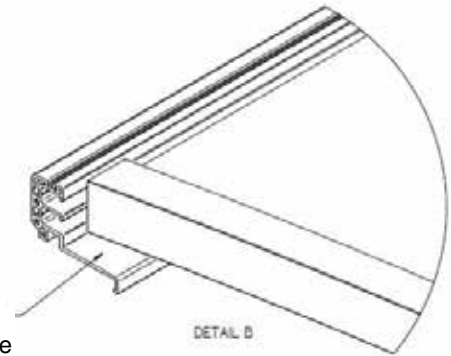

Glass Gable is seated here

DETAIL B

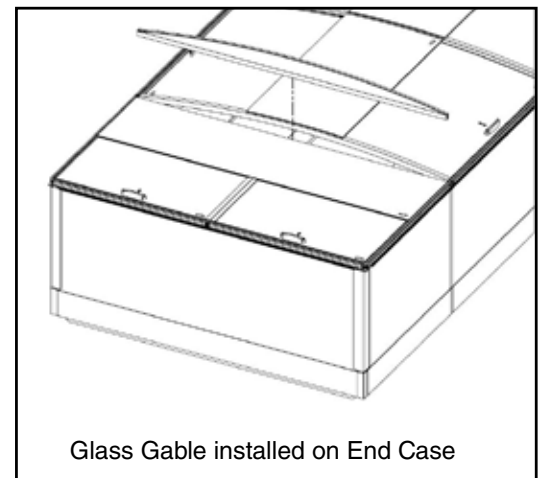
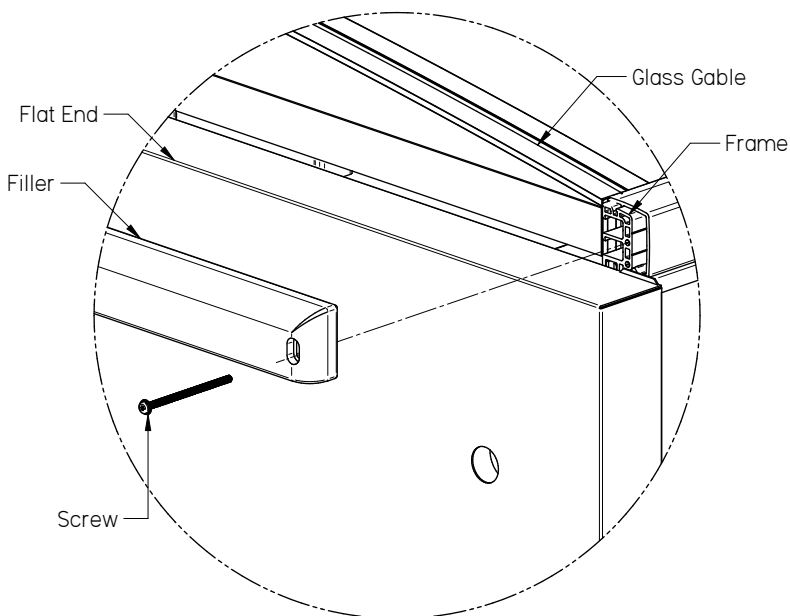

Glass Gable installed on End Case

ATTACHING GABLES (CONTOUR CASE ENDS)

1. Clean all pieces before starting the installation. Fix the inner corner to the base profile on both sides. (The larger side goes to the base profile.) Install the cover plate (use the adhesive tape, and remove the tape liner).

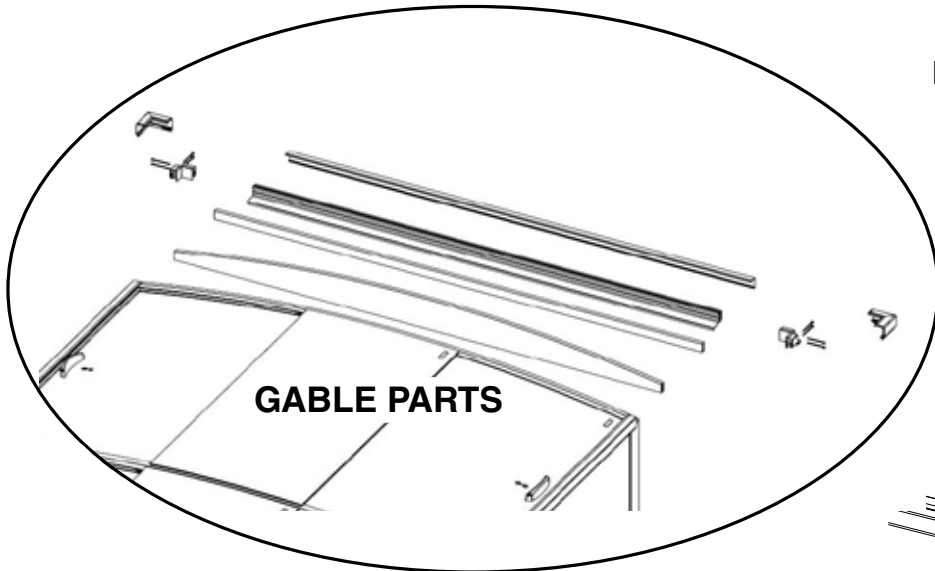
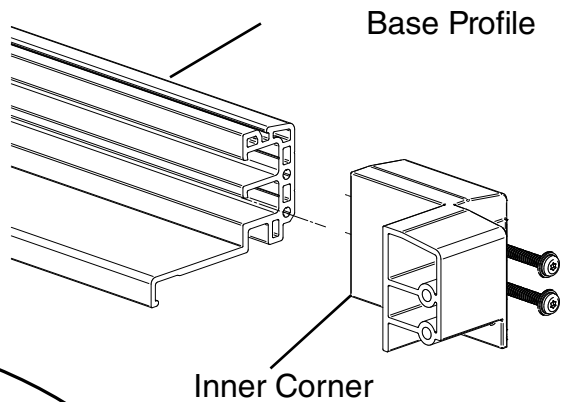

2. Install the gable (Remove the adhesive tape liner).

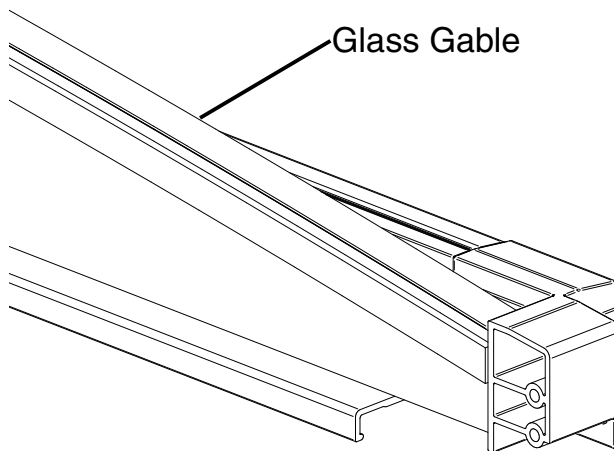
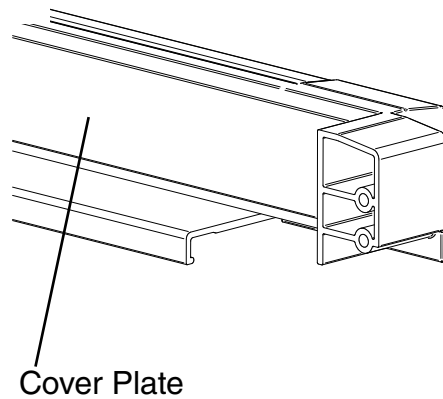

3. Seat the end decor profile into the retainers. Then, install the outer corner as shown in the illustrations below.

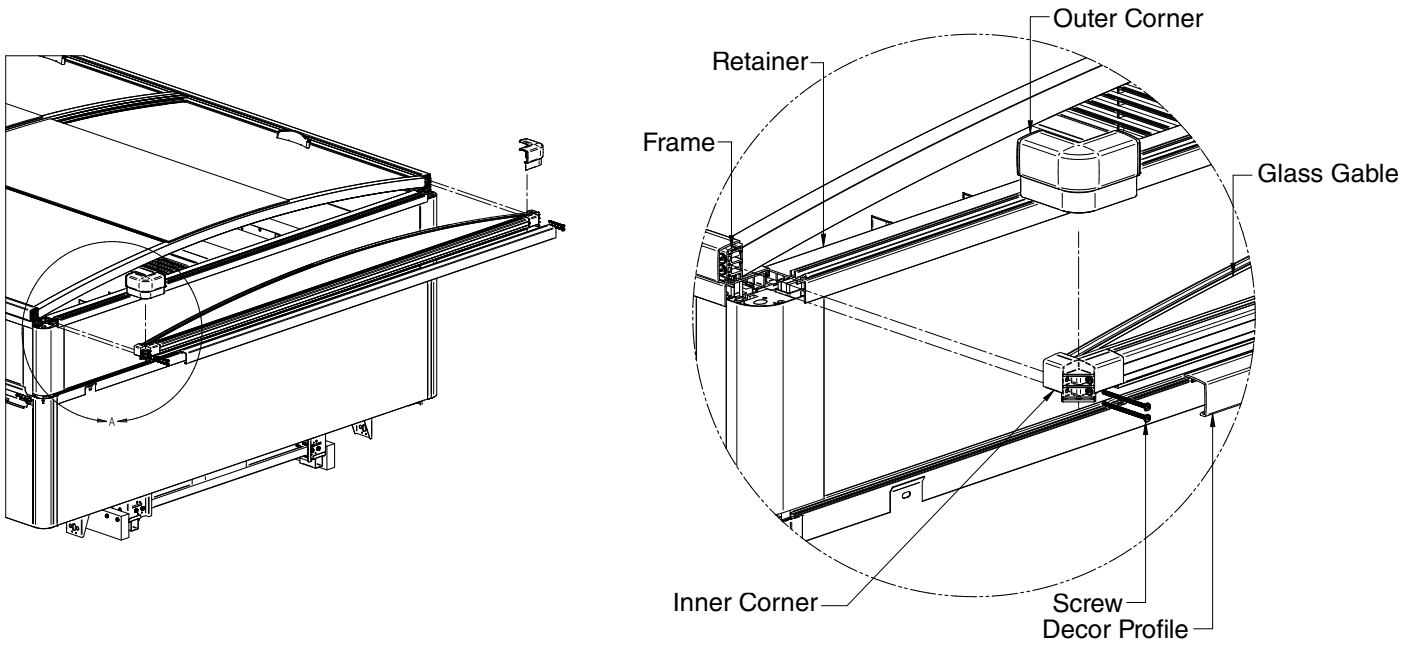

INSTALLING PTMs

1. PTMs attach to the lid frames and are one-sided or two sided.

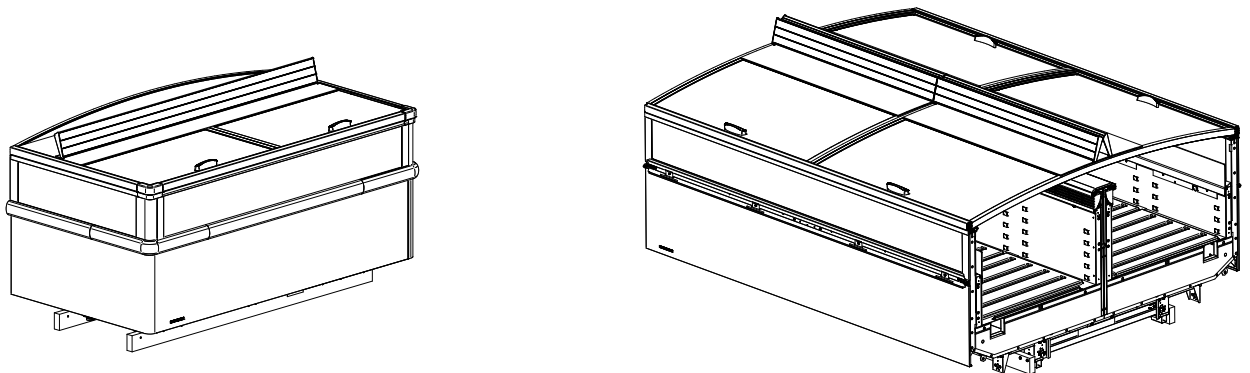

4-6 INSTALLING TRIM & GLASS GABLES

NOTES:

START UP / OPERATION

START UP

See the merchandiser's Data Sheet for refrigerant settings and defrost requirements. Bring the merchandiser down to the operating temperatures listed on the data sheet.

STOCKING

PRODUCT SHOULD NOT BE PLACED IN MERCHANDISERS UNTIL MERCHANDISER IS AT PROPER OPERATING TEMPERATURE.

Proper rotation of product during stocking is necessary to prevent product loss. Always bring the oldest product to the front and set the newest to the back.

AIR DISCHARGE AND RETURN FLUES MUST REMAIN OPEN AND FREE OF OBSTRUCTION AT ALL TIMES to provide proper refrigeration and air curtain performance. Do not allow product, packages, signs, etc. to block these grilles. Do not use non-approved shelving, baskets, display racks, or any accessory that could hamper air curtain performance.

| |
|---|
|  <h2 style="margin: 0;">CAUTION</h2> |
| <p>At no time should merchandisers be stocked beyond the load limits indicated. Improper stocking can cause poor performance that results in spoiled food.</p> |

LOAD LIMITS

Each merchandiser has a load limit decal.



SHELF LIFE OF PERISHABLES WILL BE SHORT IF LOAD LIMIT IS VIOLATED. OVERSTOCKING WILL ADVERSELY AFFECT PRODUCT TEMPERATURE AND MERCHANDISER EFFICIENCY. THE LOAD LIMIT IS THE BOTTOM OF THE INTERIOR PANEL BREAK. RECOMMENDED LOAD LIMIT PROFILES ARE SHOWN ON THE NEXT PAGE.

THE LOAD LIMIT OF THE MERCHANDISER MUST ALWAYS BE MAINTAINED. IF THE MERCHANDISER IS OVER STACKED THE GLASSES WILL NOT CONDENSATE.

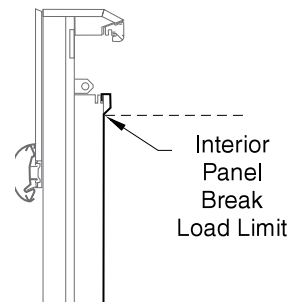

INSTALLING FDA/NSF REQUIRED THERMOMETER

The following pages provide the same information that ships with the thermometer.

This requirement does not apply to display refrigerators intended for bulk produce. (refer to page 1-1).

Please note that the tape cannot be exposed after installation.

LOAD LIMIT PROFILES

F
FWE

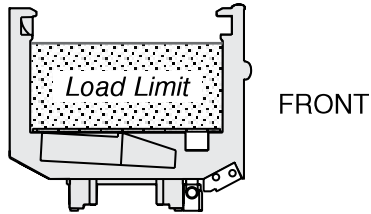

FW

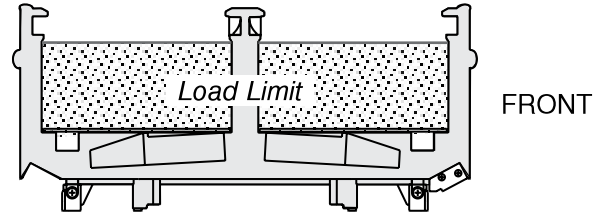

FN
FI

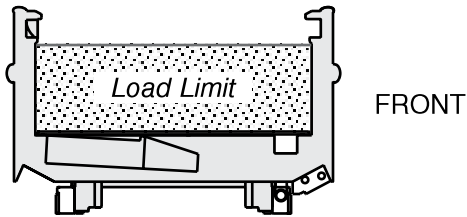

FNG
FIG

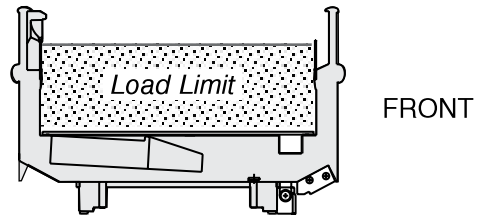

FG
FWEG

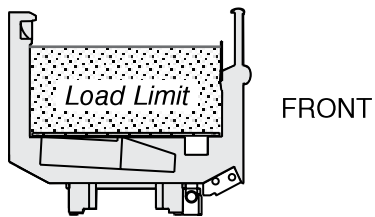

FWG

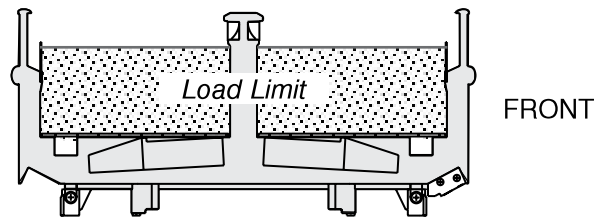

FWEGH

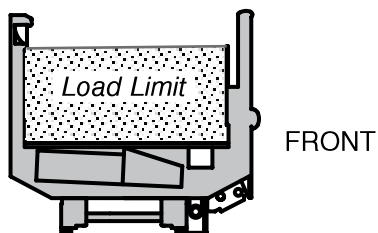

FWGH

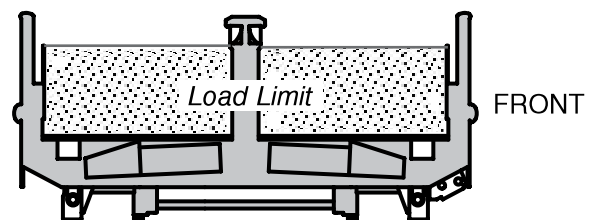

This is an NSF-7 & US FDA Food Code Required Thermometer

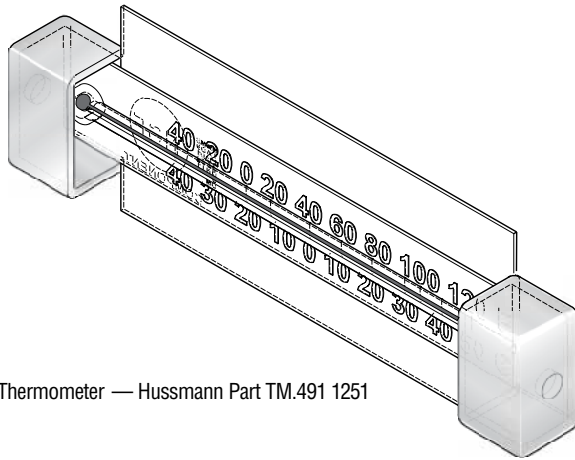

Suggested Mounting Locations in Single Deck Glass Front Merchandisers

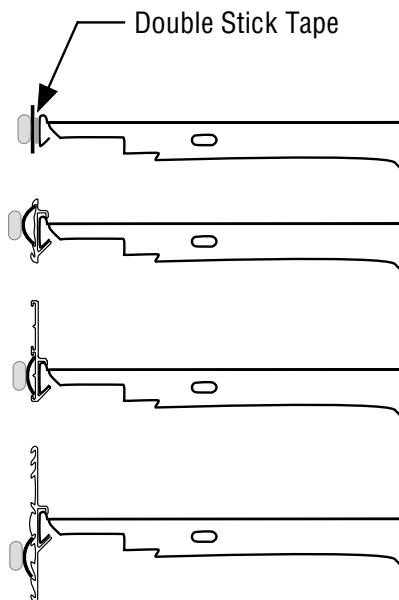
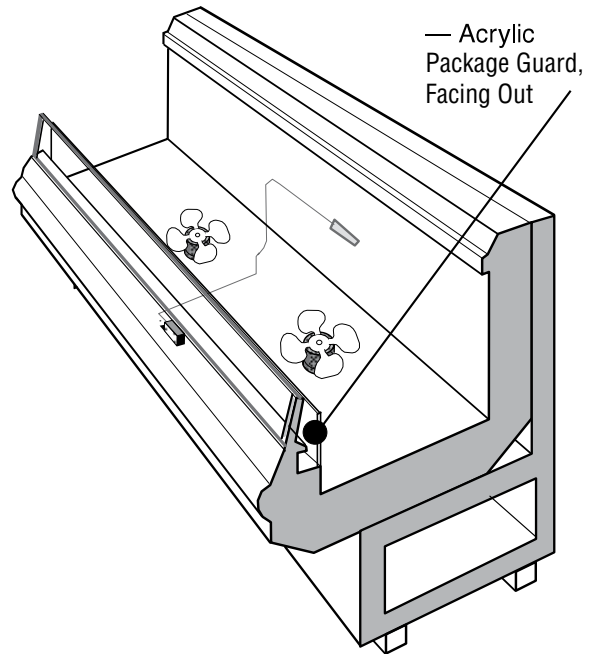

Flexible Plastic Fits in Price Tag Moldings

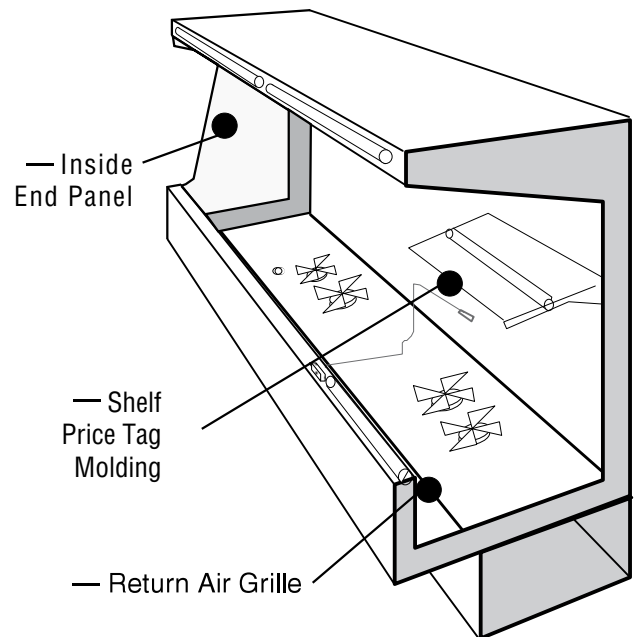

Suggested Mounting Locations in Multi-deck Merchandisers

Important – Please read!

This thermometer is provided in response to United States
Food and Drug Administration (US FDA) Food Code [<http://www.fda.gov/>]
and
National Sanitation Foundation (NSF / ANSI) Standard 7 [<http://www.nsf.org/>]

Each installation will be different depending on how the unit is stocked, shopping patterns in the department and ambient conditions of the store. The suggested locations provided herein are possible locations. It is the responsibility of the purchaser / user to determine the location within the food storage area of the unit that best meets the code requirements above.

The thermometer may need to be moved several times to find the warmest location. Mounting options include flexible plastic for price tag molding application, magnet applied to back of flexible plastic for steel end wall, and double stick tape. Tape must not be exposed after installation.

Questions about either code should be addressed to local agencies or other appropriate officials.

**Keep with merchandiser
or give to store manager.**

DO NOT DESTROY

MAINTENANCE

CARE AND CLEANING

Long life and satisfactory performance of any equipment is dependent upon the care it receives. To ensure long life, proper sanitation and minimum maintenance costs, these merchandisers should be thoroughly cleaned, all debris removed and the interiors washed down frequently.

Fan Plenum

To facilitate cleaning, the fan plenum is hinged. After cleaning be sure the plenum is properly lowered into position **OR PRODUCT LOSS WILL RESULT** due to improper refrigeration.

Exterior Surfaces

The exterior surfaces should be cleaned with a mild detergent and warm water to protect and maintain their attractive finish. **NEVER USE ABRASIVE CLEANSERS OR SCOURING PADS.**

Interior Surfaces

The interior surfaces may be cleaned with most domestic detergents, ammonia based cleaners and sanitizing solutions with no harm to the surface.

DO NOT USE:

- Abrasive cleansers and scouring pads, as these will mar the finish.
- A hose on lighted shelves or submerge the shelves in water.
- Solvent, oil or acidic based cleaners on any interior surfaces.
- Ammonia-based cleaners on acrylic parts.
- Coarse paper towels on coated glass.

WARNING

**Prevent injury.
ALWAYS SHUT POWER OFF
during cleaning process.**

Do:

- Remove the product and all loose debris to avoid clogging the waste outlet.
- Store product in a refrigerated area such as a freezer. Remove only as much product as can be taken to the freezer in a timely manner.
- First turn off refrigeration, then disconnect electrical power.
- Thoroughly clean all surfaces with soap and hot water.
DO NOT USE STEAM OR HIGH WATER PRESSURE HOSES TO WASH THE INTERIOR. THESE WILL DESTROY THE MERCHANDISERS' SEALING CAUSING LEAKS AND POOR PERFORMANCE.
- Take care to minimize direct contact between fan motors and cleaning or rinse water.
- Rinse with hot water, but do NOT flood. **NEVER INTRODUCE WATER FASTER THAN THE WASTE OUTLET CAN REMOVE IT.**
- Allow merchandisers to dry before resuming operation.
- After cleaning is completed, turn on power and refrigerant to the merchandiser.
- Verify that merchandiser is working properly.

CAUTION

Product will be degraded and may spoil if allowed to sit in a non-refrigerated area.

CAUTION

Do NOT use HOT water on COLD glass surfaces. This can cause the glass to shatter and could result in personal injury. Allow glass fronts, ends, and service doors to warm before applying hot water.

CLEANING AIRFLOW LOUVERS

Louvers should be cleaned at least every six months. Dirty louvers adversely affect model performance.

1. Remove screws and louver retainer.
2. Lift the louver, then rotate the bottom out.
3. Clean the louvers with soap and water. Dry thoroughly.
4. When completely dry, re-install louvers and retainer.

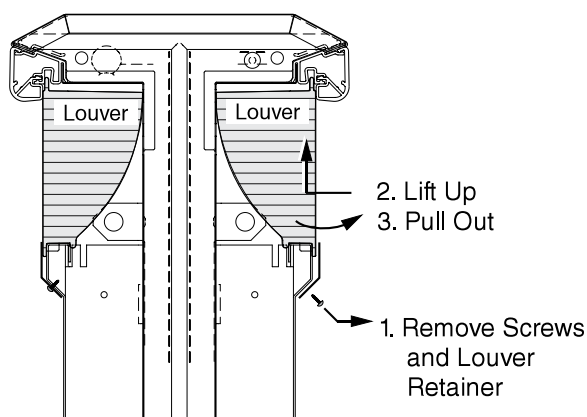

CLEANING WIRE RACKS, PANS AND INTERIOR PANELS

With the louver assembly removed, all interior wire racks, supports and drip pans may be lifted out without tools. Refer to illustration on next page.

Begin by lifting out the display racks and front and back display rack supports. Remove display pans, beginning from the left. Pans overlap when properly installed.

Carefully lift up glass package guard to clear clips attached to front panel. It is not necessary to remove clips from panel. Lift out return air grilles. The glass may be cleaned with most domestic detergents, ammonia-based cleaners and sanitizing solutions with no harm to the surface. **NEVER USE ABRASIVE CLEANSERS OR SCOURING PADS.**

Front and rear internal panels rest on interior panel supports. Panels and supports lift out.

Reinstall in reverse order.

CLEANING STAINLESS STEEL RAILS

Use non-abrasive cleaning materials, and always polish with grain of the steel. Use warm water or add a mild detergent to the water and apply with a cloth. Always wipe rails dry after wetting.

Use alkaline chlorinated or non-chlorine containing cleaners such as window cleaners and mild detergents. Do not use cleaners containing salts as this may cause pitting and rusting of the stainless steel finish. Do not use bleach.

Clean frequently to avoid build-up of hard, stubborn stains. A stainless steel cleaning solution may be used periodically to minimize scratching and remove stains.

Rinse and wipe dry immediately after cleaning. Never use hydrochloric acid (muriatic acid) on stainless steel.

FWG-L Shown — Other Low Temperature Excel Model Parts are Similar

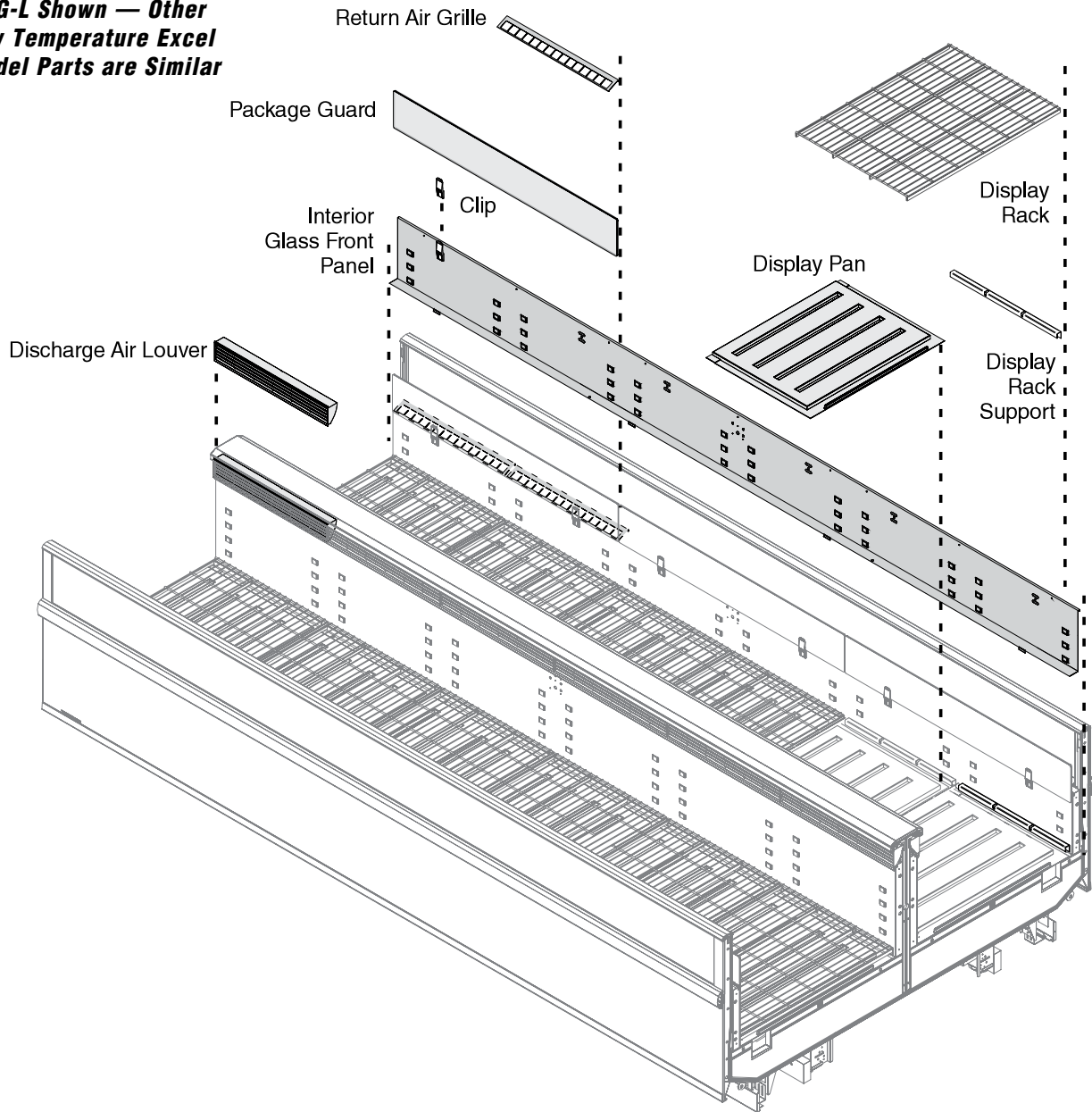

CLEANING COILS

NEVER USE SHARP OBJECTS AROUND COILS. Use a soft brush or vacuum brush to clean debris from coils. **Do not puncture coils!** Do not bend fins. Contact an authorized service technician if a coil is punctured, cracked, or otherwise damaged.

ICE in or on the coil indicates the refrigeration and defrost cycle is not operating properly. Contact an authorized service technician to determine the cause of icing, and to make adjustments as necessary. To maintain product integrity, move all product to a cooler until the unit has returned to normal operating temperatures.

REMOVING REAR FLUE GLASS FOR CLEANING (FIG-L & FNG-L)

1. Remove louvers, then remove the discharge deflector brackets. The flue glass (with retainer) may then be lifted out.
2. Remove interior panels to facilitate thorough cleaning.
3. Reinstall in reverse order.

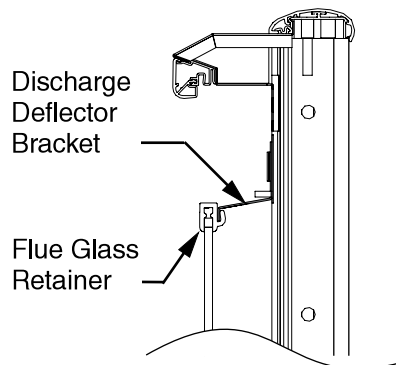
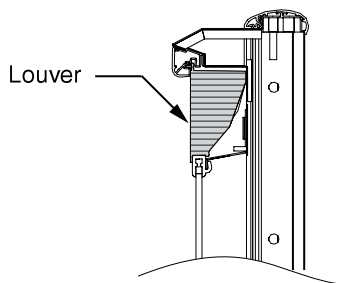

CLEANING SLIDING GLASS LIDS

Glass and sliding track should be cleaned weekly. Clean tracks with a soft cloth and a mild detergent. Never use high pressure water, abrasive cleaners, solvents, ammonia, chloric acid, or oil-based products. Clean glass with a soft cloth and non-ammonia glass cleaner.

REMOVING SCRATCHES FROM BUMPER

Most scratches and dings can be removed using the following procedure.

1. Use steel wool to smooth out the surface area of the bumper or top rail.
2. Clean area.
3. Apply vinyl or car wax and polish surface for a smooth glossy finish.

CLEANING UNDER MERCHANDISERS

Remove splashguards not sealed to floor. Use a vacuum with a long wand attachment to remove accumulated dust and debris from under the merchandiser.

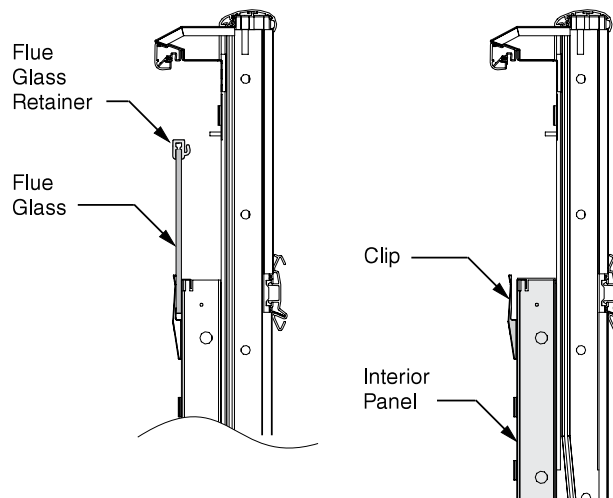

SERVICE

GENERAL

Refer to the case data sheet for each model to identify the general location of components.

WARNING

— LOCK OUT / TAG OUT —

To avoid serious injury or death from electrical shock, always disconnect the electrical power at the main disconnect when servicing or replacing any electrical component. This includes, but is not limited to, such items as doors, lights, fans, heaters, and thermostats.

REPLACING FAN MOTORS AND BLADES

See cross section for location of evaporator fans. Should it ever be necessary to service or replace the fan motors or blades be certain that the fan blades are re-installed correctly.

For access to evaporator fans:

1. Turn off power.
2. Remove wire racks and display pans from the compartment being serviced.
3. **Disconnect fan from wiring harness.**
4. Remove fan blade.
5. Remove screws holding fan motor/bracket assembly to plenum and remove assembly.
6. Replace fan motor/bracket assembly and reinstall screws.
7. Reinstall fan blade.
8. Reconnect fan to wiring harness.
9. Turn on power.
10. Verify that motor is working and blade is turning in the correct direction.
11. Replace display pans and wire racks. Bring merchandiser to operating temperature before restocking.

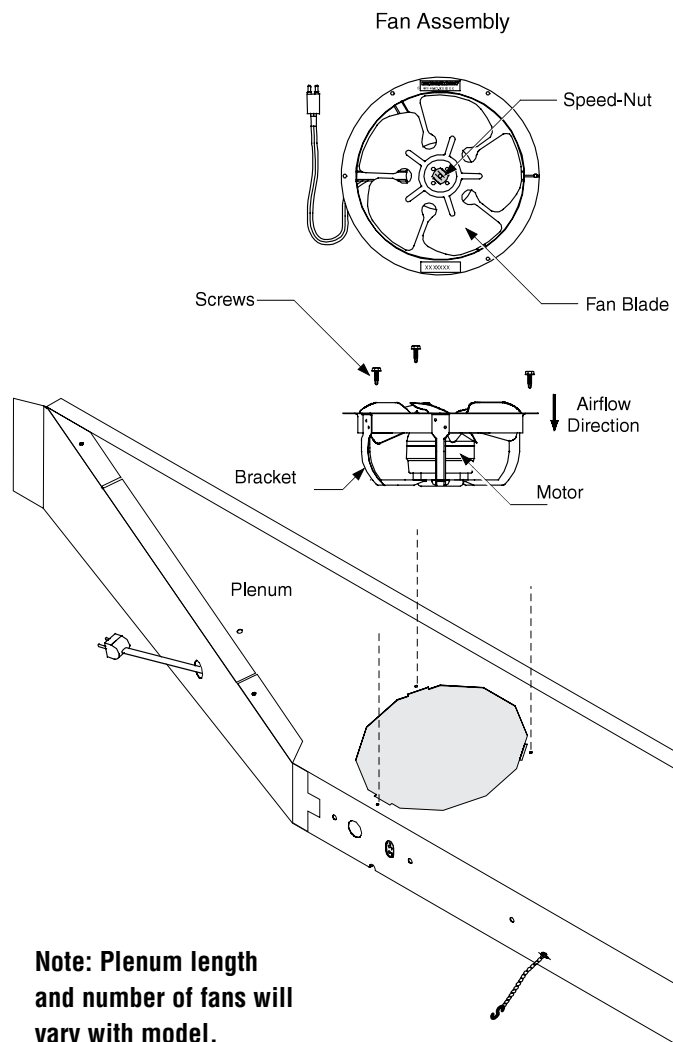

Note: Plenum length and number of fans will vary with model.

REPLACING CASSETTE GLASS**STEP 1**

Open the glass(es) adjacent to the glass that must be removed.

 **WARNING**

Only qualified personnel should install and service this equipment. Servicing is only to be done by factory authorized personnel. Personal Protection Equipment (PPE) is required. The images on the following pages are for demonstration purposes only. Wear safety glasses, gloves, protective boots or shoes, long pants, and a long-sleeve shirt or arm guards when working with this equipment and while handling glass. Contact your Hussmann representative to arrange servicing.

**STEP 2**

Click out one of the top corner sliding pads (glass will stay in place without support).

Scan QR code for a short video of this procedure.

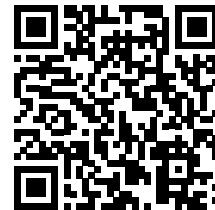

STEP 3

Click out lower corner sliding pad on the same side (make sure to support glass).



STEP 4

Get a second person (or an object) to support the side of the glass that is clicked out.



STEP 5

Click out opposite top corner sliding pad.

**STEP 6**

Grab handle for additional support.



STEP 7

Click out final sliding pad in opposite lower corner.



STEP 8

Take out glass (first a little into the cabinet and then it can be twisted out).



FRAME TYPES

The glass is already assembled in the frame cassettes. Case retainers are factory-installed around the perimeter rails of the case. The retainers fit and snap to the lid frames. All other parts are field installed. Below are the frames used for each case model. See table below.

FW CASES

3FT GL DOOR FW - Standard cassette for FW6 cases
 3FT L GL DOOR FW - LH cassette only applies next to LH flat end for FW6 cases
 3FT R GL DOOR FW - RH cassette only applies next to RH flat end for FW6 cases
 MODULE-4FT GL DOOR FW - Standard cassette for FW4, FW8 and FW12
 MODULE-4FT L GL DOOR FW - LH cassette only applies next to LH flat end for FW4, FW8 and FW12 cases
 MODULE-4FT R GL DOOR FW - RH cassette only applies next to RH flat end for FW4, FW8 and FW12 cases
 MODULE-4FT NAR WDO GL DOOR FW - This cassette only applies to FW4 with flat ends on both sides
 MODULE-END CASE GL DOOR FW - Standard cassette for FWE cases

F CASES

MODULE-4FT GL DOOR F - Standard cassette for F8 and F12
 MODULE-4FT L GL DOOR F - LH cassette only applies next to LH flat end for F8 and F12 cases
 MODULE-4FT R GL DOOR F - RH cassette only applies next to RH flat end for F8 and F12 cases

FI CASES

3FT GL DOOR FI - Standard cassette for FI6 cases
 3FT L GL DOOR FI - LH cassette only applies next to LH flat end for FI6 cases
 3FT R GL DOOR FI - RH cassette only applies next to RH flat end for FI6 cases
 MODULE-4FT GL DOOR FI - Standard cassette for FI8 and FI12
 MODULE-4FT L GL DOOR FI - LH cassette only applies next to LH flat end for FI6 and FI12 cases
 MODULE-4FT R GL DOOR FI - RH cassette only applies next to RH flat end for FI6 and FI12 cases

FN CASES

3FT GL DOOR FN - Standard cassette for FN6 cases
 3FT L GL DOOR FN - LH cassette only applies next to LH flat end for FN6 cases
 3FT R GL DOOR FN - RH cassette only applies next to RH flat end for FN6 cases
 MODULE-4FT GL DOOR FN - Standard cassette for FN4, FN8 and FN12
 MODULE-4FT L GL DOOR FN - LH cassette only applies next to LH flat end for FN4, FN6 and FN12 cases
 MODULE-4FT R GL DOOR FN - RH cassette only applies next to RH flat end for FN4, FN6 and FN12 cases
 MODULE-4FT NAR WDO GL DOOR FN - This cassette only applies to FN4 with flat ends on both sides

FN-L and FN-GL use two glasses and are curved (2 sided).



F-L, and F-GL wall cases use two glasses and are curved.



FW-L, FW-GHL & FW-GL use three glasses and are curved (2 sided).



FI-L and FI-GL use three glasses and are curved (2 sided).



FWEL and FW EGL use three glasses.



See installation steps on the next page. See separate data sheet for list of parts.

NOTE:

Hussmann does not recommend using a power drill. If using a power drill, Do NOT use more than 2 N/m torque.

REMOVING GLASS DOOR LID ASSEMBLIES

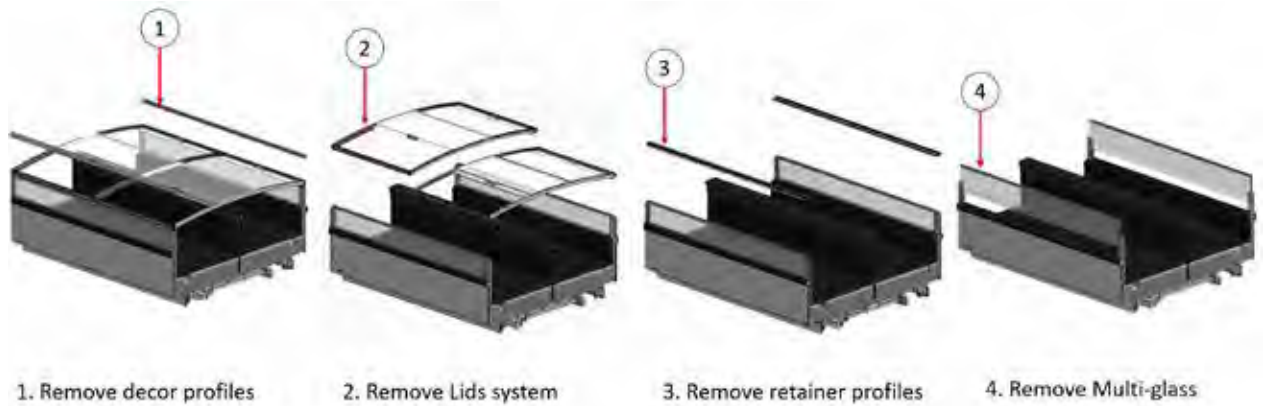

REPLACING ELECTRIC DEFROST HEATER

These heaters are installed at the front of the coils. They may be accessed by lifting the fan plenums. To replace:

1. Turn off power to merchandiser.
2. Remove wire racks and display pans from the compartment being serviced.
3. Hinge up and fasten the fan plenum to the interior back panel with chain and hook provided.
4. Unplug the heater from the heater harness.
5. Remove the heater from the face of the coil by rotating the support tab far enough to free the heater element.
6. Position the new heater and rotate the support tab back to the original position.
7. Reconnect heater to wiring harness.
8. Lower the fan plenum to operating position.
9. Reconnect power.
10. Verify heater is working properly.
11. Replace display pans and wire racks. Bring merchandiser to operating temperature before restocking.

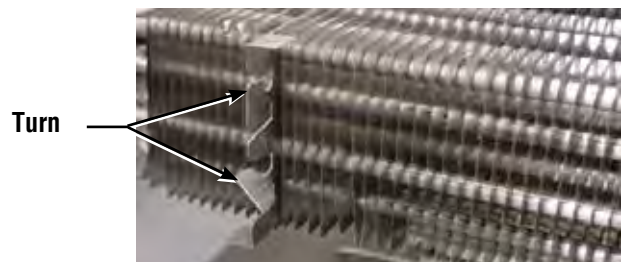
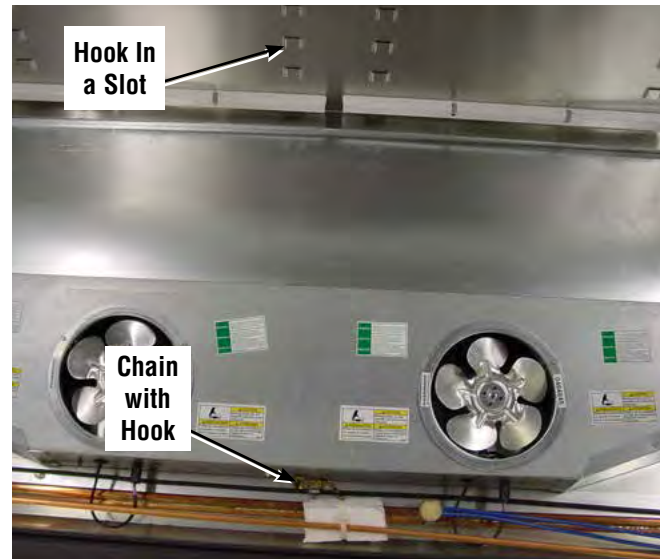
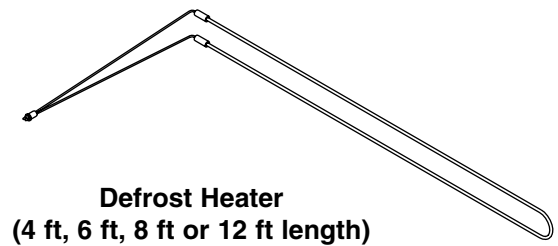

REPLACING RETURN AIR HEATER

To replace the heater:

1. Turn OFF the power to the merchandiser.
2. Remove return grilles, package guard and interior panel from the compartment being serviced.
3. Remove screw and wireway cover.
4. Unplug existing return air heater. The return air heater plug is routed on RH side from front of merchandiser (end opposite the main serial plate).
5. Remove screws and retainer.
6. Remove the foil tape and heater from the retainer.
7. Clean thoroughly. Remove all adhesive and residue. Wipe surface with alcohol to ensure new heater tape will adhere properly.
8. Install new heater and tape in retainer as shown.
9. Reinstall retainer, routing plug to jumper harness; plug in.
10. Reinstall wireway cover, interior panel, package guard, return air grilles, display pans and wire racks.
11. Turn on power to merchandiser and check for proper operation.

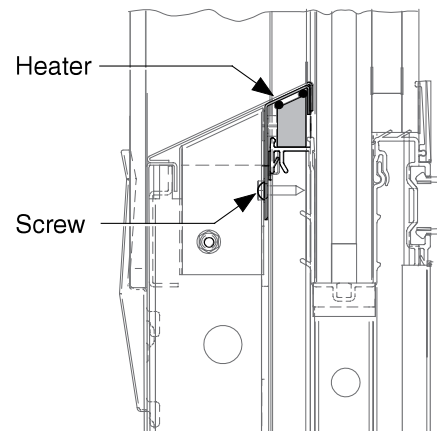
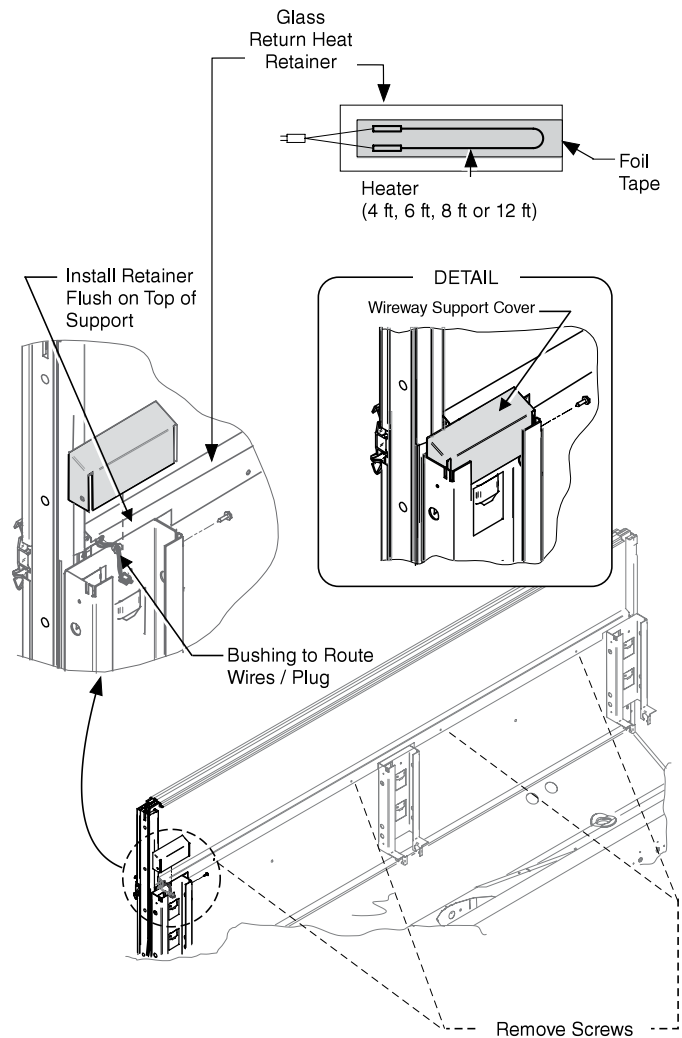
**WARNING**

— LOCK OUT / TAG OUT —

To avoid serious injury or death from electrical shock, always disconnect the electrical power at the main disconnect when servicing or replacing any electrical component. This includes, but is not limited to, such items as doors, lights, fans, heaters, and thermostats.

REPLACING NOSING ANTI-SWEAT HEATER

To replace the heater:

1. Turn OFF the power to the merchandiser.
2. Remove a louver from one end. It doesn't matter which end.
3. Remove exterior nosing extrusion by placing fingers at the back end of the extrusion and pulling forward until it separates from the interior nosing extrusion.

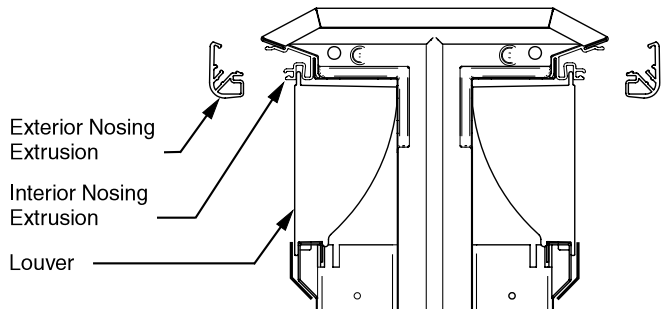

4. Unplug and remove existing anti-sweat heater. The anti-sweat heater plug is routed on RH side from front of merchandiser (end opposite the main serial plate).
5. Install new anti-sweat heater as shown and route plug to jumper harness; plug in.

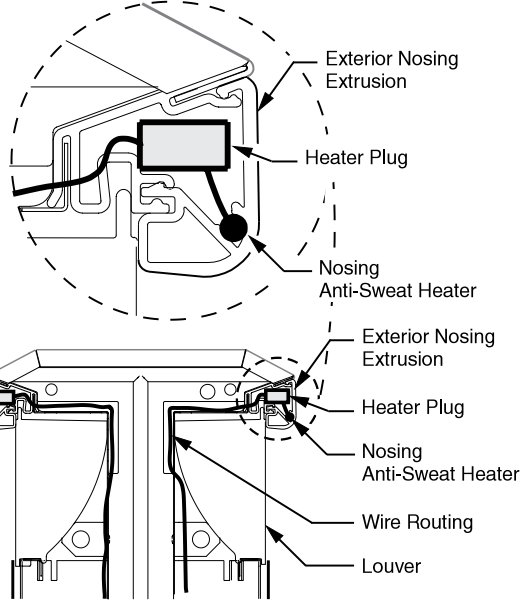

6. Do the following to reattach exterior nosing extrusion to interior nosing extrusion:
There are two joining locations "A" and "B" that must be fastened to the interior nosing extrusion. "A" can be positioned in place by hand. Use a rubber mallet to snap "B" into place at interior extrusion. A light to medium tap is all that is required.

NOTE: It is easier to reinstall plastic extrusion if wide PTM is removed.

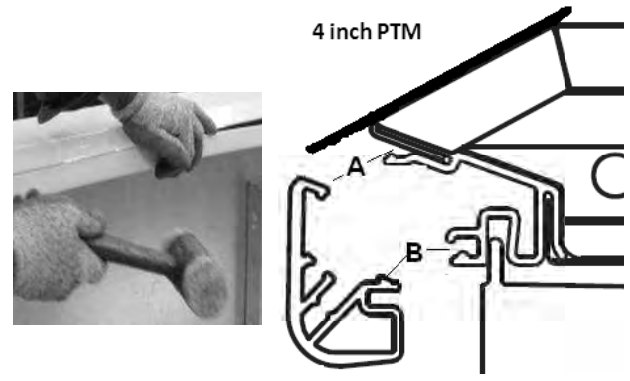

7. Replace discharge air louver, retainers and fasteners.

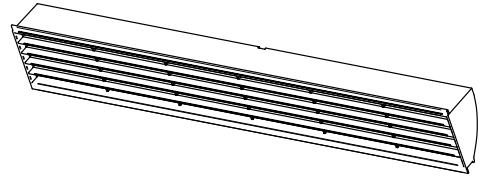

8. Turn on power to merchandiser, and check for proper operation.

⚠ WARNING

— LOCK OUT / TAG OUT —

To avoid serious injury or death from electrical shock, always disconnect the electrical power at the main disconnect when servicing or replacing any electrical component. This includes, but is not limited to, such items as doors, lights, fans, heaters, and thermostats.

REPLACING PRODUCT SIDE HEATER (FWGH & FWEHG ONLY)

To replace the heater:

1. Turn OFF the power to the merchandiser.
2. Remove return grilles, package guard and interior panel from the compartment being serviced.
3. Remove the pop rivets. Rivets will be drilled out. Unplug existing product side heater. Heater is routed on RH side from front of merchandiser (end opposite the main serial plate).
4. Clean thoroughly. Remove all adhesive and residue. Wipe surface with alcohol to ensure new heater tape will adhere properly.
5. Install new heater and tape in retainer as shown.
6. Reinstall retainer, routing plug to jumper harness; plug in.
7. Reinstall wireway cover, interior panel, package guard, return air grilles, display pans and wire racks.
8. Turn on power to merchandiser and check for proper operation.

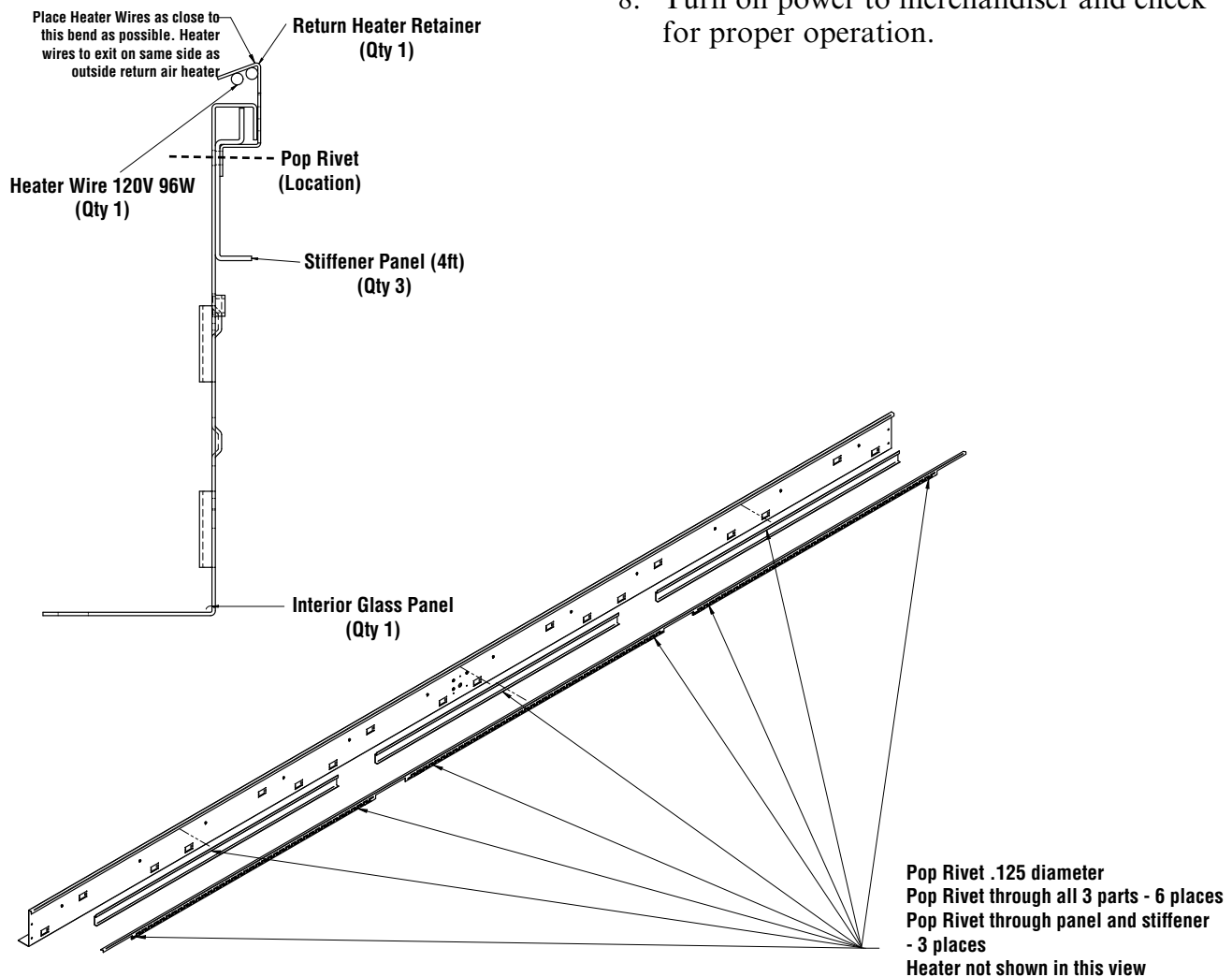

REPLACING DRIP PAN HEATER

1. Turn off power to the merchandiser.
2. Remove wire racks and display pans from the compartment being serviced.
3. Unplug the heater from the heater harness.
4. Remove heater lead wire from interior panel supports.
5. Remove all screws and clips, then remove the heater.
6. Position the new heater. Apply new acrylic sealer to the underside of clips. Carefully *reinstall clips in their original position*.
7. Route heater lead wire through the interior panel supports.
8. Reconnect harness.
9. Turn on power to merchandiser and check for proper operation.
10. Reinstall display pans and wire racks.

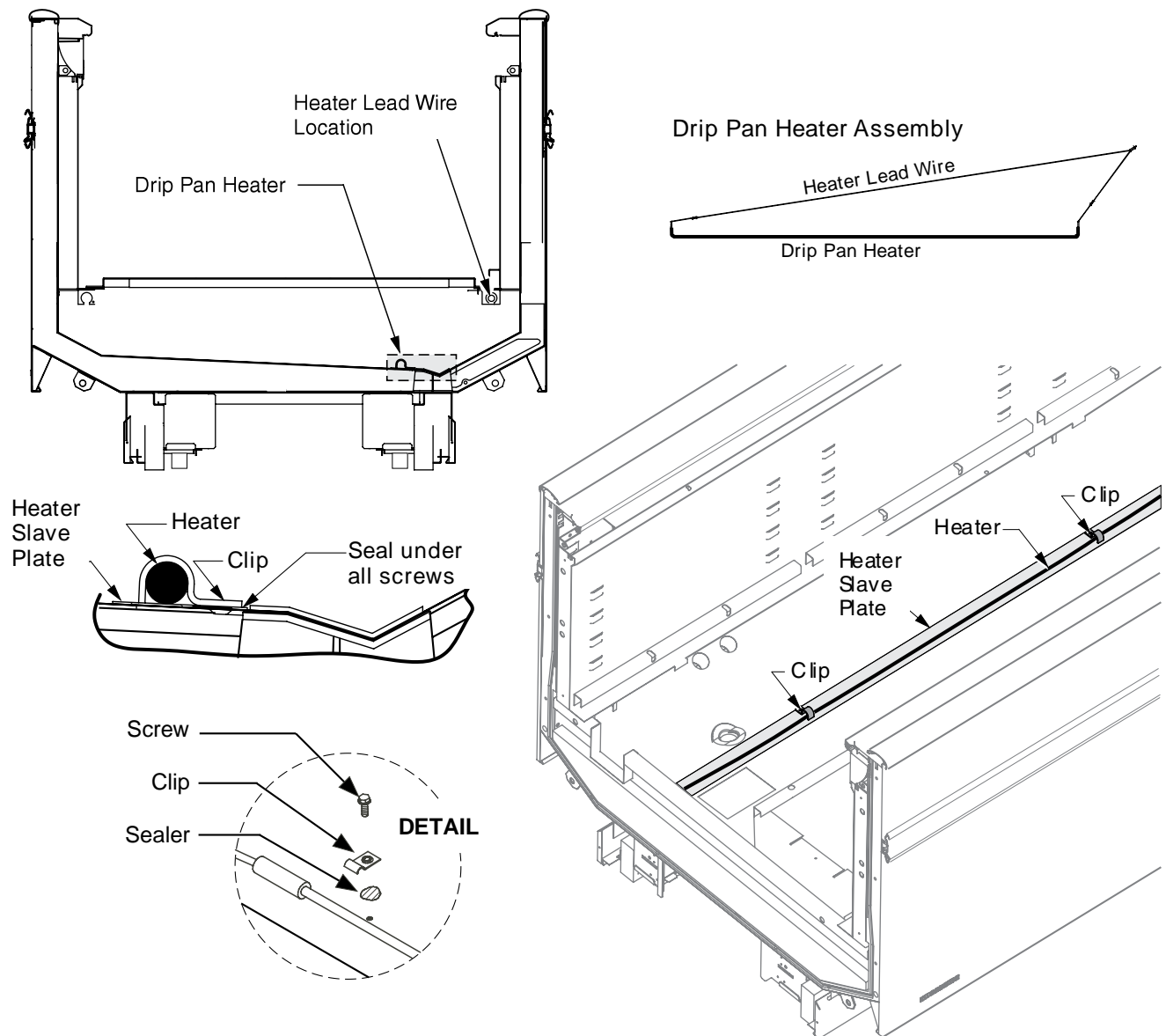

REPLACING DISCHARGE THERMOPANE GLASS ASSEMBLY (FNGL and FIGL)

Requires TWO (2) people.

Always use gloves when handling glass.

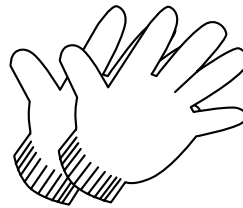

Always Use Gloves
When Handling Glass!!

1. Turn off power to merchandiser.
2. Remove glass lids and frame assembly, louvers, package guards, discharge rear deflector module and hand rail. (Hand rail removal is shown on Page 6-9.)
3. Disconnect glass pane heater lead wires from the wiring junctions.
4. With one person standing at each end of glass, lift the thermopane glass assembly straight up to remove it from its retainer channel and the end posts.
5. To install glass, have one person hold each end of the thermopane glass assembly and carefully lower it into the retainer channel and end posts.

NOTE: It may be necessary to use a wide, thin tool (such as a putty knife) to keep trim from obstructing glass positioning.

6. Reconnect glass pane heater lead wires.
7. Re-install hand rail, discharge rear deflector, package guards, louvers, and re-install frame assembly.
8. Turn on power. Verify glass lids are sliding properly. Verify that heater is working properly.

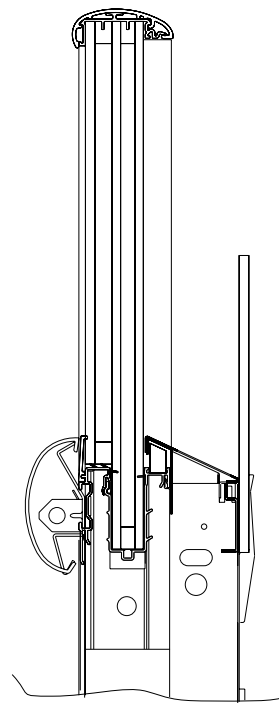

WARNING

— LOCK OUT / TAG OUT —

To avoid serious injury or death from electrical shock, always disconnect the electrical power at the main disconnect when servicing or replacing any electrical component. This includes, but is not limited to, such items as doors, lights, fans, heaters, and thermostats.

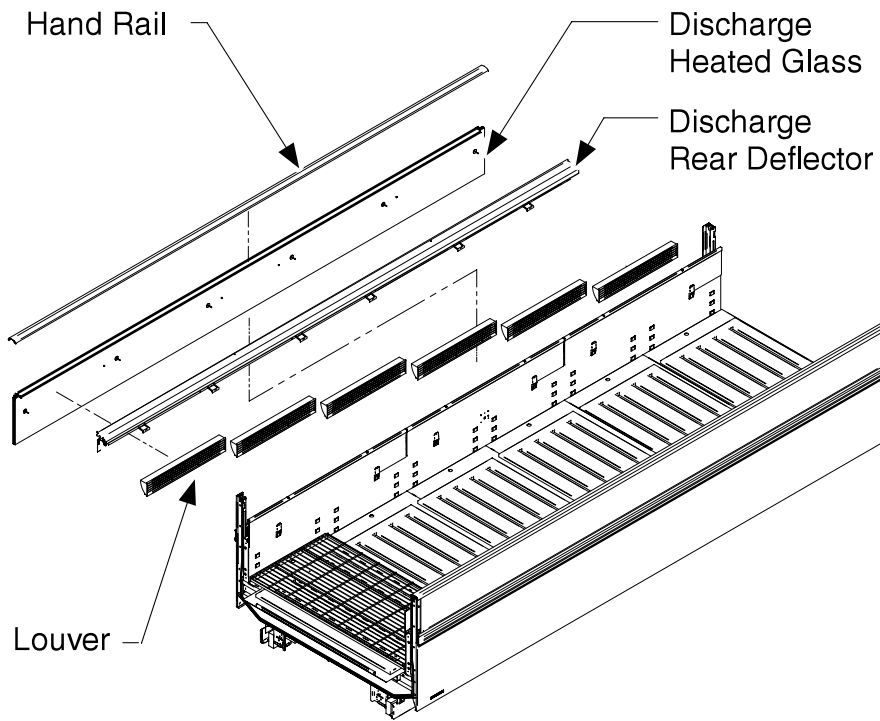
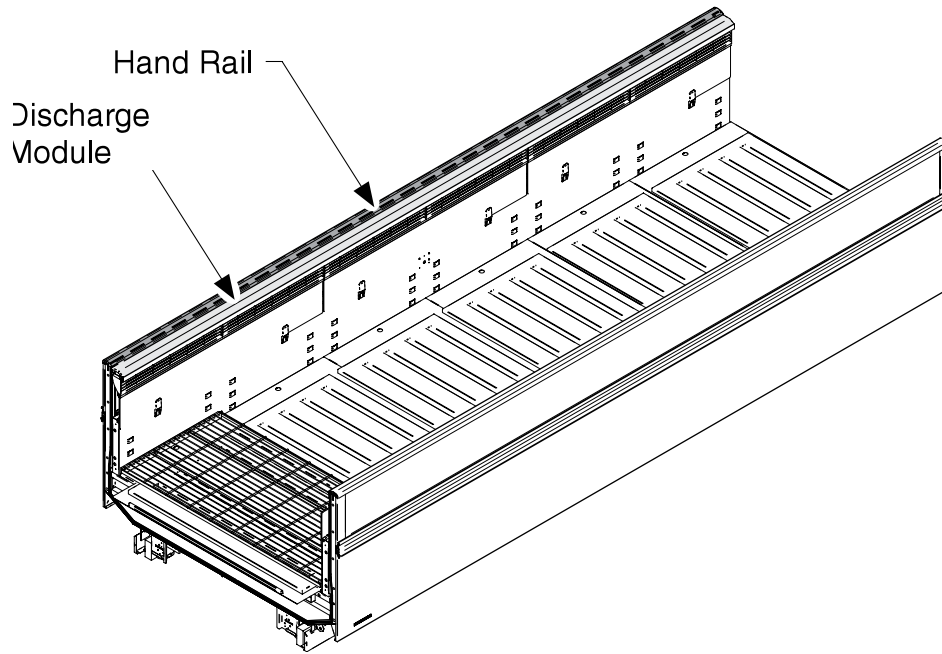

REPLACING RETURN THERMOPANE GLASS ASSEMBLY

Requires TWO (2) people.

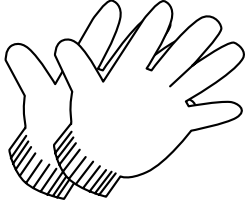

Always use gloves when handling glass.

1. Turn off power to merchandiser.
2. Remove glass lids and frame assembly. Remove hand rail.
3. Disconnect glass pane heater lead wires from the wiring junctions.
4. With one person standing at each end of the glass, lift the thermopane glass assembly straight up to remove it from its retainer channel and end posts.
5. To install glass, have one person hold each end of the thermopane glass assembly and carefully lower it into the retainer channel and end-posts.

Note: It may be necessary to use a wide thin tool (such as a putty knife) to keep trim from obstructing glass positioning.

6. Reconnect glass pane heater lead wires.
7. Replace hand rail. Re-install frame assembly and glass lids.
8. Turn on power. Verify glass lids are sliding properly. Verify the heater is working properly.

WARNING

— LOCK OUT / TAG OUT —

To avoid serious injury or death from electrical shock, always disconnect the electrical power at the main disconnect when servicing or replacing any electrical component. This includes, but is not limited to, such items as doors, lights, fans, heaters, and thermostats.

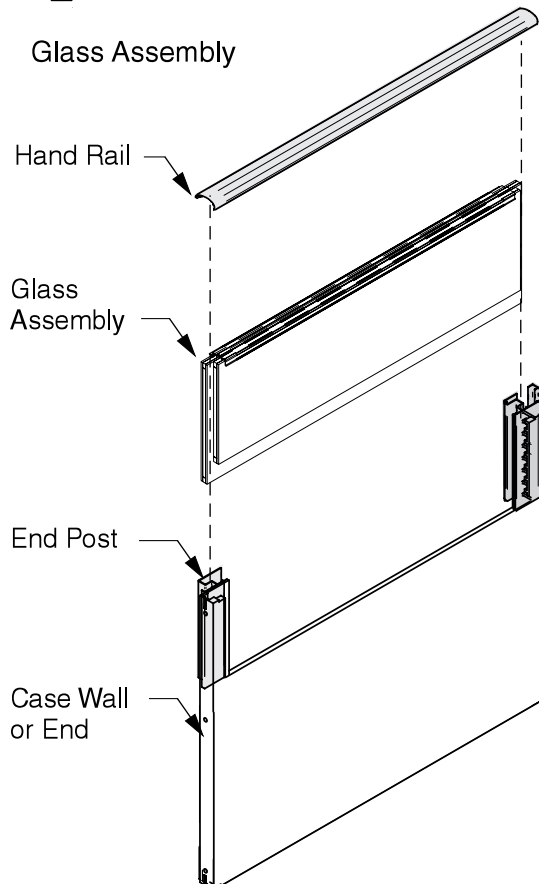
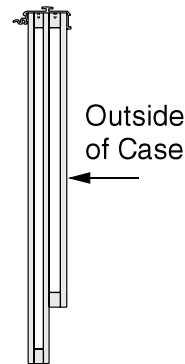

POWER SUPPLY & LED REPLACEMENT

Power supplies are installed in the raceways. Connect switch is input per wiring diagram. The switch is installed in side of the raceway.

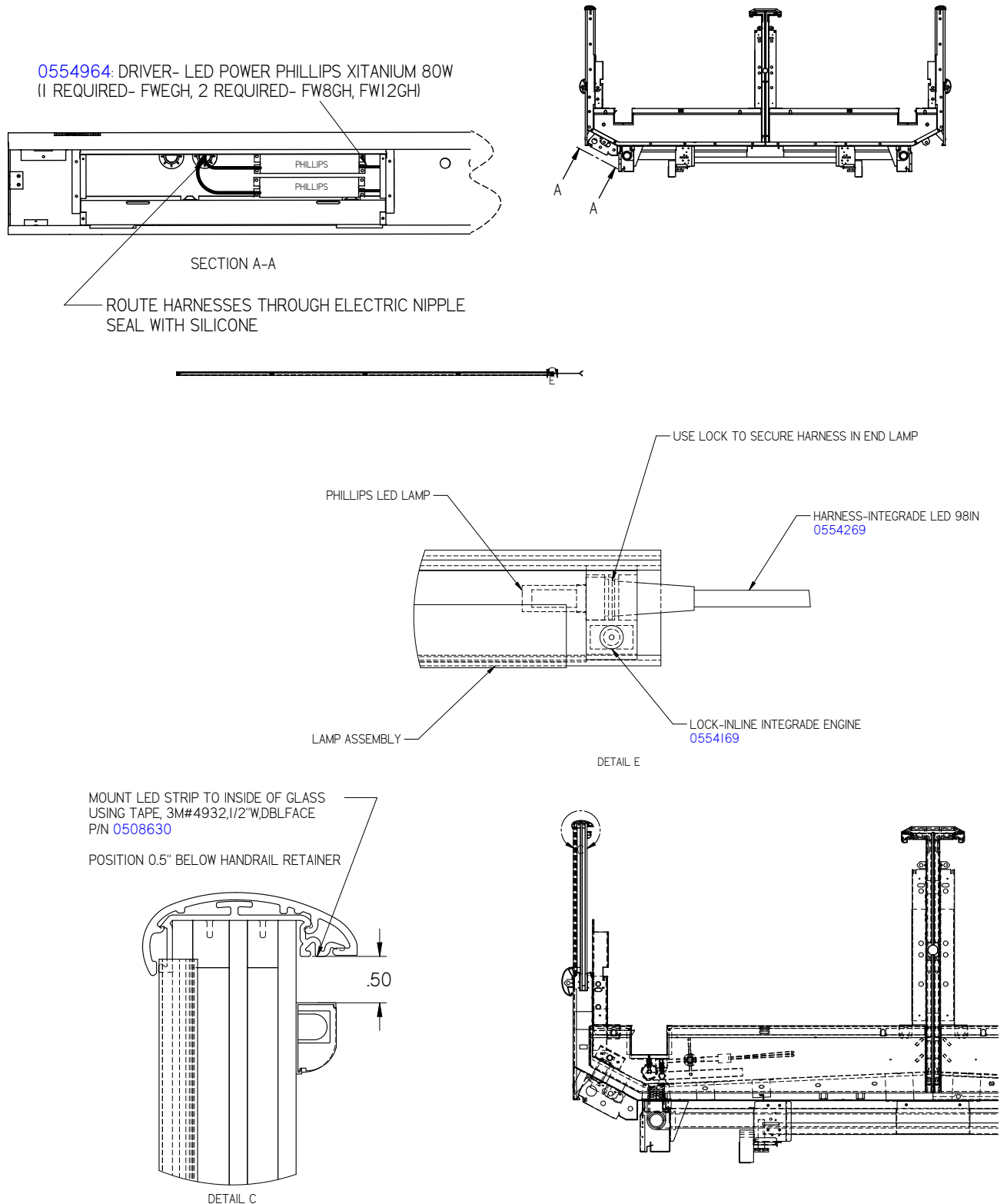

REPAIRING ALUMINUM COIL

The aluminum coils used in Hussmann merchandisers may be easily repaired in the field. Materials are available from local refrigeration wholesalers.

Hussmann recommends the following solders and technique:

Solders

Aladdin Welding Products Inc.

P.O. Box 7188

1300 Burton St.

Grand Rapids, MI 49507

Phone: 1-800-645-3413

Fax: 1-800-645-3414

X-Ergon

1570 E. Northgate

P.O. Box 2102

Irving, TX 75062

Phone: 1-800-527-9916

NOTE:

Hussmann Aluminum melts at1125°F

Aladdin 3-in-1 rod at732°F

X-Ergon Acid core at455°F

Technique:

1. Locate Leak.
2. REMOVE ALL PRESSURE.
3. Brush area UNDER HEAT.
4. Use PRESTOLITE TORCH ONLY. Number 6 tip.
5. Maintain separate set of stainless steel brushes, and USE ONLY ON ALUMINUM.
6. Tin surface around area.
7. Brush tinned surface UNDER HEAT, thoroughly filling the open pores around leak.
8. Repair leak. Let aluminum melt solder, NOT the torch.
9. Don't repair for looks. Go for thickness.
10. Perform a leak check.
11. Wash with water.
12. Cover with a good flexible sealant.

HUSSMANN[®]

To obtain warranty information or other support,
contact your Hussmann representative.

Please include the model and
serial number of the product.