

# HUSSMANN®

## *Low Temperature* Single Deck Wall & Island Merchandisers



### *Installation & Operation Manual*

Shipped with Merchandiser  
Data Sheets

**IMPORTANT**  
Keep in store for  
future reference!

**P/N 0467434\_P**  
Excel Series  
December 2021



## BEFORE YOU BEGIN

Read these instructions completely and carefully.



This manual was written in accordance with originally prescribed equipment that is subject to change. Hussmann reserves the right to change or revise specifications and product design in connection with any feature of our products.

## PERSONAL PROTECTION EQUIPMENT (PPE)



Only qualified personnel should install and service this equipment. Servicing is only to be done by factory authorized personnel. Personal Protection Equipment (PPE) is required. Wear safety glasses, gloves, protective boots or shoes, long pants, and a long-sleeve shirt when working with this equipment and while handling glass. Observe all precautions on tags, stickers, labels and literature attached to this equipment. Component parts shall be replaced with like components. Service is to be performed by factory-authorized service personnel, so as to minimize the risk of possible ignition due to incorrect parts or improper service. Contact your Hussmann representative to arrange servicing.

### ANSI Z535.5 DEFINITIONS

The safety of our customers and employees are paramount. The precautions and procedures described in this manual are intended as general methods for safe use of this equipment. Please be sure to comply with the precautions described in this manual to protect you and others from possible harm, and follow OSHA standards for safety.

The definitions at right are used to clarify the magnitude and urgency of harm and damage, considering problems arising from misuse. Relative to their potential danger, the definitions are divided into four parts according to ANSI Z535 Series.



• **DANGER** – Indicate[s] a hazardous situation which, if not avoided, will result in death or serious injury.



• **WARNING** – Indicate[s] a hazardous situation which, if not avoided, could result in death or serious injury.



• **CAUTION** – Indicate[s] a hazardous situation which, if not avoided, could result in minor or moderate injury.

• **NOTICE** – Not related to personal injury – Indicates[s] situations, which if not avoided, could result in damage to equipment.

**TABLE OF CONTENTS**

<b>ANSI Z535.5 DEFINITIONS</b> . . . . .	v	<b>REFRIGERATION / ELECTRICAL</b>	
<b>EXCEL INSTALLATION TOOL LIST</b> . . . . .	v	Refrigerant . . . . .	2-1
<b>INSTALLATION</b>		Refrigerant Piping . . . . .	2-1
UL Listing . . . . .	1-1	Connection Location . . . . .	2-1
Federal / State Regulations . . . . .	1-1	Multiplexing . . . . .	2-2
Location . . . . .	1-1	Line Sizing . . . . .	2-2
Shipping Damage . . . . .	1-2	Oil Traps . . . . .	2-2
Unloading . . . . .	1-2	Pressure Drop . . . . .	2-2
Serial Plate Location . . . . .	1-2	Insulation . . . . .	2-3
Exterior Loading . . . . .	1-3	Branch Line Piping . . . . .	2-3
Merchandisers Shipped with		Suction Line - All Defrost . . . . .	2-3
End Installed . . . . .	1-3	Liquid Line — Off-time and Electric Defrost. . . . .	2-4
Shipping Braces . . . . .	1-3	Liquid Line — Koolgas Defrost . . . . .	2-4
Shipping Rider . . . . .	1-3	Front to Rear and/or End Interconnects . . . . .	2-5
Merchandiser Leveling . . . . .	1-3	Refrigeration Thermostat . . . . .	2-5
Joining Instruction . . . . .	1-5	Defrost Termination Thermostat . . . . .	2-5
Joining Merchandisers in Line . . . . .	1-6	CDA Sensor (Optional) . . . . .	2-5
Joining End Merchandiser to		Merchandiser Electrical Data . . . . .	2-6
Wide Island . . . . .	1-9	Field Wiring . . . . .	2-6
Parent to Parent Installation KEY . . . . .	1-11	Electrical Connections . . . . .	2-6
Parent to End Installation KEY . . . . .	1-13	Identification of Wiring . . . . .	2-6
Fasten End Frames . . . . .	1-14	Wiring Color Code . . . . .	2-6
Seal Merchandisers . . . . .	1-15	<b>DRIP PIPING AND SPLASHGUARDS</b>	
Install Splashguard Brackets . . . . .	1-15	Waste Outlet and Water Seal. . . . .	3-1
Replacing Interior Panels and Discharge		Installing Drip Piping. . . . .	3-2
Air Louvers. . . . .	1-15	Drip Piping Lineup Arrangements . . . . .	3-3
Offsetting Bumper . . . . .	1-16	Installing Splashguards . . . . .	3-4
Bumper Removal . . . . .	1-16	Installing Splashguards on End and End Case. . . . .	3-6
Offsetting Bumper (for End Merchandisers) . . . . .	1-18		
Offsetting Bumper (for Merchandiser Lineup) . . . . .	1-19		
Offsetting Plastic Top Rail . . . . .	1-20		
Optional Stainless Steel Top Rail . . . . .	1-21		
Installing Flue Glass — FNG & FIG . . . . .	1-22		
Installing Flue Glass Clamp			
(FWGH & FWEHG) . . . . .	1-22		
Installing Partitions . . . . .	1-22		
Installing End Assemblies . . . . .	1-23		

CONTINUED ON PAGE IV.

**IMPORTANT**  
**KEEP IN STORE FOR FUTURE REFERENCE**  
*Quality that sets industry standards!*



12999 St. Charles Rock Road • Bridgeton, MO 63044-2483  
 U.S. & Canada 1-800-922-1919 • Mexico 1-800-890-2900

[www.husmann.com](http://www.husmann.com)

© 2021 Husmann Corporation

## CONTENTS (CONTINUED)

**START UP / OPERATION**

Start up .....	4-1
Stocking .....	4-1
Load Limits .....	4-1
Installing FDA/NSF Required Thermometer .....	4-1
Load Limit Profiles .....	4-2

**MAINTENANCE**

Care and Cleaning .....	5-1
Fan Plenum .....	5-1
Exterior Surfaces .....	5-1
Interior Surfaces .....	5-1
Cleaning Airflow Louvers .....	5-2
Cleaning Wire Racks, Pans, and Interior Panels .....	5-2
Cleaning Stainless Steel Rails .....	5-2
Cleaning Coils .....	5-3
Removing Rear Flue Glass for Cleaning (FIG & FNG) .....	5-4
Removing Scratches from Bumper .....	5-4
Cleaning Under Merchandisers .....	5-4

**SERVICE**

General .....	6-1
Replacing Fan Motors and Blades .....	6-1
Replacing Electric Defrost Heater .....	6-2
Replacing Hand Rail Heater (Solid Fronts) .....	6-3
Replacing Hand Rail Heater (Glass Fronts) .....	6-5
Replacing Return Air Heater .....	6-7
Replacing Product Side Heater (FWGH & FWEHG Only) .....	6-8
Replacing Nosing Anti-sweat Heater .....	6-9
Center Flue Superstructure Anti-Sweat Heater Replacement (FW-S) .....	6-10
Replacing Drip Pan Heater .....	6-11
Replacing Discharge Thermopane Glass Assembly (FNG and FIG) .....	6-12
Replacing Return Thermopane Glass Assembly .....	6-14
Replacing Hand Rail .....	6-15
Replacing Panel Edge Guard .....	6-15
Superstructure LED Power Supply Replacement (FW-S) .....	6-16
Night Curtain Adjustment (FW-S) .....	6-16
Repairing Aluminum Coil .....	6-17

**WARRANTY**

# EXCEL INSTALLATION TOOL LIST

\*\*\*\*\*

## ANSI Z535.5 DEFINITIONS



• **DANGER** – Indicate[s] a hazardous situation which, if not avoided, will result in death or serious injury.



• **WARNING** – Indicate[s] a hazardous situation which, if not avoided, could result in death or serious injury.



• **CAUTION** – Indicate[s] a hazardous situation which, if not avoided, could result in minor or moderate injury.

• **NOTICE** – *Not related to personal injury* – Indicates[s] situations, which if not avoided, could result in damage to equipment.

### Unloading From Trailer:

Lever Bar (also known as a Mule, Johnson Bar, J-bar, Lever Dolly, and pry lever)  
Moving Dolly (two for 12-ft merchandiser)

### Setting Merchandiser Line-Up:

Level, 4 ft suggested  
Ratchet  
1/4 in. Socket  
5/16 in. Socket  
1/2 in. Socket  
Battery Drill/Screw Gun  
Caulking Gun  
10 in. Adjustable Crescent Wrench

## REVISION HISTORY (CONTINUED)

### REVISION P

1. Added **FW-S** Service instructions for night curtain, anti-sweat heaters, and LED power supply

### REVISION N

1. Updated UL Listing, Page 1-1; California Warning, Page 1-2; Updated, Page 1-21; Refrigerant, Page 2-1

### REVISION M

1. Updated Shipping Braces, Page 1-2; Gasket drawing, Page 1-5; Moved Picture, Page 1-6; additional text, Page 1-7, 1-9, 1-10 and 1-12

## REVISION HISTORY

### REVISION L

1. **FWGH** and FWGEH Load Limit Profile
2. **FWGH** and FWGEH Bolt Location Drawings Page 1-10, 1-12
3. Added Replacing Product Side Heater
4. Flue Glass for **FWGH** 1-21

### REVISION K

1. Updated Prep Merchandiser #2, page 1-5.
2. Added Replacing Interior Panels and Louvers, page 1-14.
3. Added coil cleaning, page 5-3.
4. Revised Step 6, page 6-8.

### REVISION J

1. Removed adjustable legs, page 1-3, throughout.

### REVISION I — not used

### REVISION H

1. Added 3-in. space requirement from walls, page 1-3
2. Added merchandiser lineup bumper instruction to Offsetting Bumper Section, pages 1-15 to 1-18.
3. Added Drip Piping Support 24 in. requirement from Drain Hubs, pages 3-2 and 3-3
4. Added Rail Heater wiring harness drawings, pages 6-3 to 6-6.

### REVISION G

1. Revised drip piping pitch, page 3-1.
2. Added stainless steel rail maintenance, page 5-2.

### REVISION F

1. Added Joining Merchandisers in Line (3 photos). page 1-6.
2. Added Bumper Retainer Bracket drawing, page 1-7.
3. Added Joining End Merchandiser to Wide Island (3 photos), page 1-8.
4. Added Socket Adapter Photo, page 1-10, 1-12.
5. Removed “V” from drawing **FW** to **FWE**, page 1-12.
6. Added Bumper Retainer photo, page 1-15.
7. Revised instruction information, page 1-15.
8. Added NOTES, page 1-6 to 1-9.
9. Changed bumper tool information, page 1-14.
10. Added Replacing Hand Rail Heater, page 6-3 to 6-4.

### REVISION E

1. Added ANSI definitions, page iv.
2. Added bumper removal instruction to Offsetting Bumper, pages 1-12 — 1-14.
3. Added offsetting plastic hand rail procedure, page 1-15.
4. Added SS Top Rail Joint Trim, page 1-16.
5. Added Installing Flue Glass — FNG & FIG, page 1-17.
6. Updated NSF Thermometer, pages 4-3 and 4-4.
7. Added center flue removal instruction, page 5-3.
8. Updated WARNING, CAUTION, and NOTICE boxes throughout.
9. Added URL, contact phone numbers to bottom of even-numbered pages.

### REVISION D

1. Changed to factory installed flange nut fastener for joining end merchandiser to wide island parent, page 1-7.
2. Changed KEY on page 1-8; affects joining illustrations on pages 1-8 and 1-9.
3. Changed joining order, page 1-8.
4. Changed 3 in. Hex Head screw to 3 1/2 in. Hex Head screw, pages 1-8 and 1-10.
5. Changed END KEY on page 1-10.
6. Added fastener location for joining **FWG** to **FWEG**, page 1-10.

### REVISION C

1. Added URL, contact phone numbers, page iii.
2. Removed alignment pin from joining sequence, pages 1-5, 1-6, 1-8, 1-9, 1-10 and 1-13.
3. Changed KEY on page 1-8.
4. Changed END KEY on page 1-10.
5. Changed 4 in. screw to 4 1/2 in. TAP bolt, page 1-10.
6. Deleted one location from end joining, page 1-10.
7. Added refrigeration shroud, page 2-1.
8. Added Do not use coarse paper towels, page 5-1.

### REVISION B

1. Added joining location, pages 1-8 and 1-9.
2. Changed fastening order for joining, page 1-10.
3. Added Louver Retainer, page 5-2.
4. Added Wireway Cover, page 6-4.

### REVISION A

1. Added note, page 3-2.

**ORIGINAL ISSUE** — September 2005

## INSTALLATION

### UL LISTING

These merchandisers are manufactured to meet ANSI/ UL 471 standard requirements for safety. Proper installation is required to maintain the listing.

### FEDERAL / STATE REGULATION

These merchandisers at the time they are manufactured, meet all federal and state/provincial regulations. Proper installation is required to ensure these standards are maintained. Near the serial plate, each merchandiser carries a label identifying the environment for which the merchandiser was designed for use. A Type II fan speed control kit is required for each merchandiser to operate at Type II conditions.

**ANSI/NSF-7 Type I – Display Refrigerator / Freezer  
Intended for 75°F (24°C) / 55% RH Ambient Application**

**ANSI/NSF-7 Type II – Display Refrigerator / Freezer  
Intended for 80°F / 55% RH Ambient Application**

**ANSI/NSF-7 – Display Refrigerator  
Intended for Bulk Produce**

### LOCATION

These merchandisers are designed for displaying products in air conditioned stores where temperature is maintained at or below the ANSI / NSF-7 specified level and relative humidity is maintained at or below 55%.

Placing refrigerated merchandisers in direct sunlight, near hot tables or near other heat sources could impair their efficiency.

Like other merchandisers, these are sensitive to air disturbances. Air currents passing around merchandisers will seriously impair their operation. Do NOT allow air conditioning, electric fans, open doors or windows, etc. to create air currents around the merchandisers.

Product should always be maintained at proper temperature. This means that from the time the product is received, through storage, preparation and display, the temperature of the product must be controlled to maximize the life of the product.

**Excel wall models have internal frames. A 3 inch (76 mm) space between the rear of the merchandiser and wall must be maintained for air circulation. However, in high ambient conditions, sweating may still occur. If this happens install a method of forced ventilation such as a fan ventilation kit.**

### Wide Island Fronts

BE SURE TO POSITION WIDE ISLAND MERCHANDISER FRONTS PROPERLY.

The front of a wide island merchandiser is readily identified by the location of the serial plate. Since all electrical and refrigeration connections will be made at the front side, the fronts will need to be positioned according to the store plan layout.

## 1-2 INSTALLATION

### SHIPPING DAMAGE

All equipment should be thoroughly examined for shipping damage before and during unloading.

This equipment has been carefully inspected at our factory. Any claim for loss or damage must be made to the carrier. The carrier will provide any necessary inspection reports and/or claim forms.

#### Apparent Loss Or Damage

If there is an obvious loss or damage, it must be noted on the freight bill or express receipt and signed by the carrier's agent; otherwise, carrier may refuse claim.

#### Concealed Loss Or Damage

When loss or damage is not apparent until after equipment is uncrated, retain all packing materials and submit a written request to the carrier for inspection, within 15 days.

### UNLOADING

Improper handling may cause damage to the merchandiser when unloading.

To avoid damage:

1. Do not drag the merchandiser out of the trailer. Use a Johnson bar (mule).
2. Use one dolly to remove the merchandiser from the trailer.
3. Use two dollies to move cases to lineup.

### SERIAL PLATE LOCATION

Direct a flashlight through the return air grille to locate the serial plate. **BE SURE TO POSITION WIDE ISLAND MERCHANDISER FRONTS PROPERLY.**

The front of a wide island merchandiser is readily identified by the location of the serial plate affixed to the inside of the left front assembly. Since all electrical and refrigeration connections will be made at the front side, the fronts will need to be positioned according to the store plan layout. A secondary serial number sticker is put on the exterior nosing on the discharge side. It provides the model, serial number and manufacture date.

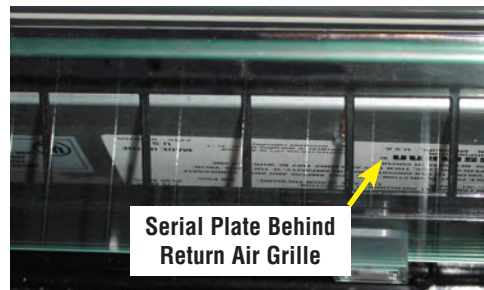

This warning does not mean that Hussmann products will cause cancer or reproductive harm, or is in violation of any product-safety standards or requirements. As clarified by the California State government, Proposition 65 can be considered more of a 'right to know' law than a pure product safety law. When used as designed, Hussmann believes that our products are not harmful. We provide the Proposition 65 warning to stay in compliance with California State law. It is your responsibility to provide accurate Proposition 65 warning labels to your customers when necessary. For more information on Proposition 65, please visit the California State government website.

## EXTERIOR LOADING

**Do NOT walk on top of merchandiser** because damage to the merchandiser and serious personal injury could occur. **THEY ARE NOT STRUCTURALLY DESIGNED TO SUPPORT EXCESSIVE EXTERNAL LOADING** such as the weight of a person. Do not place heavy objects on the merchandiser.

## MERCHANDISERS SHIPPED WITH END INSTALLED

Be careful not to damage the factory installed end while moving the merchandiser. Make sure that lifting tools are positioned past the end and beneath the support bar.

## SHIPPING BRACES

Move the merchandiser as close as possible to its permanent location and then remove all packaging. Check for damage before discarding packaging. Remove all separately packed accessories such as kits and pan displays. Remove end braces, and discard hardware. Exercise caution at all times when moving merchandisers with up-tilt riders. They are top-heavy and should never be left in the vertical position.

WARNING

**AVOID SERIOUS PERSONAL INJURY. Up-tilt riders are top-heavy and may fall over. Never leave uptilt rider in vertical position. Use caution when moving.**

**Do not remove shipping braces until the merchandisers are positioned for installation.**

**Do not stand or walk on top of merchandiser because falling off could cause personal injury.**

## SHIPPING RIDER

Each case is shipped on a rider to protect the factory installed legs, and to make positioning the merchandiser easier. **DO NOT remove the rider until the case has been positioned.** Once the rider is removed, the case must be lifted – **NOT PUSHED**– to reposition. To remove the rider, remove bolts attaching rider to each leg.

## MERCHANDISER LEVELING

Merchandisers must be installed level to ensure proper operation of the refrigeration system and to ensure proper drainage of defrost water. During all steps of setting, joining and leveling merchandisers, close attention to position and operation must be maintained.

*NOTE:* BEGIN LINEUP LEVELING FROM THE HIGHEST POINT OF THE STORE FLOOR.

### Preparation

1. Using store blueprints, measure and mark on floor the exact dimensions/locations of the merchandiser footprint. **A three (3) inch space is required behind each wall merchandiser, or lineup of merchandisers to prevent condensation. A three (3) inch space is also required at ends of merchandiser, or merchandiser lineup to prevent condensation.**
2. Snap a chalk line for the front and rear positions of the base legs.
3. Mark the location of each joint from front to back lines.

## 1-4 INSTALLATION

4. **FLOORS ARE NOT LEVEL!!!** When joining two or more merchandisers, all cases in the lineup must be leveled on the same plane, left to right and front to back. This means that the entire lineup must be brought up to the level of the highest merchandiser in the lineup.

Along the lines previously marked, find the highest point of the floor by:

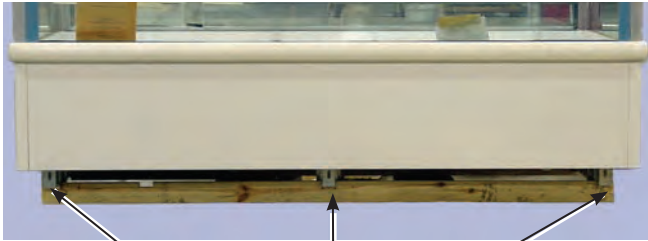

**Remove Bolts from Front**

- Walking the floor and noticing any dips or mounds;
- Using a string level or laser level; and
- Using a transit.

### Leveling

Position the first merchandiser at the highest point on the floor. Work outward from that point to create the merchandiser line-up.

Use a 48 inch (1220 mm) or longer level for end-to-end leveling. The discharge nosing of the merchandiser is a good location for the level at the rear of the merchandiser (center of wide island), and the handrail or return nosing is a good location for the level at the front of the merchandiser. For leveling the merchandiser front-to-rear, a 24 inch (610 mm) level should be placed on the flange of the merchandiser end frame. Suggested level locations are shown in the following illustrations on the next page.

### Leveling Wall Merchandisers

Level the case by all four corners. Start at the rear by placing the provided shims as needed under each end of the rear base rail. The shims are long enough to allow adjoining wall cases to be leveled with the same shim. **When the rear of the case is level end-to-end, move to the front of the case.** Use shims as needed at each front corner so that the front is also level from end-to-end and front-to-rear.

The merchandiser should be solidly supported at least every 4 feet (1220 mm). Once the merchandiser is level, if any gaps are present under the base rail, shims should be inserted approximately in line with the center front support legs to support the rear of the case. At the front of the case, insert shims under each of the center legs so that they support the front of the merchandiser.

## NOTICE

**A 3-inch space is required from walls at rear and ends of merchandiser(s) to prevent condensation.**

### Leveling Narrow, Intermediate, Wide Island or End Merchandisers

Position the first merchandiser at the highest point. Set a long level (4 ft [1220 mm] or more) on top of the discharge air flue. Insert shims until the merchandiser is level from end to end and from front to back. Check all 6 legs on 8 ft (2438 mm) merchandisers, or 8 legs on 12 ft (3658 mm) merchandisers.

**NOTE:** To avoid removing concrete flooring, begin lineup leveling from the highest point of the store floor.

### JOINING INSTRUCTIONS

Sectional construction means that two or more merchandisers may be joined in line yielding one long continuous display requiring only one pair of ends.

**ALL JOINTS MUST BE AIRTIGHT TO PREVENT FORMATION OF ICE OR CONDENSATION.**

#### Prep Merchandiser

1. Check to be sure that merchandisers are level. Locate Joining Kit and check contents.
2. Remove wire racks and display pan. Before removing interior front and back panels,

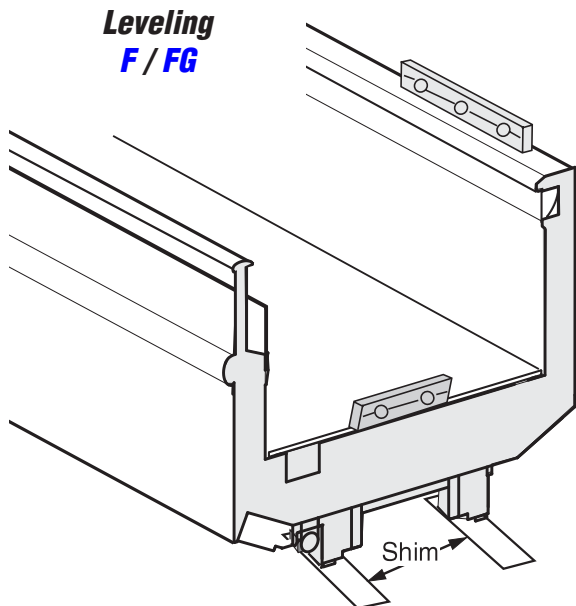
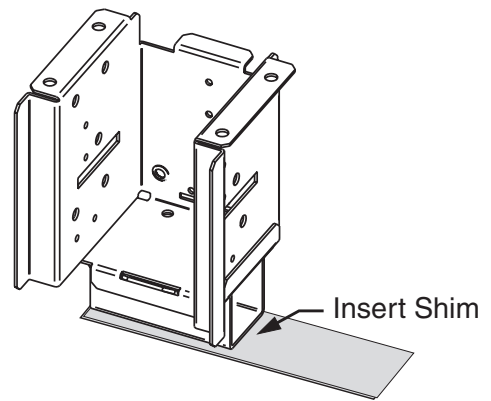

**NOTE:** Do not place levels on Display Pans or on Racks.

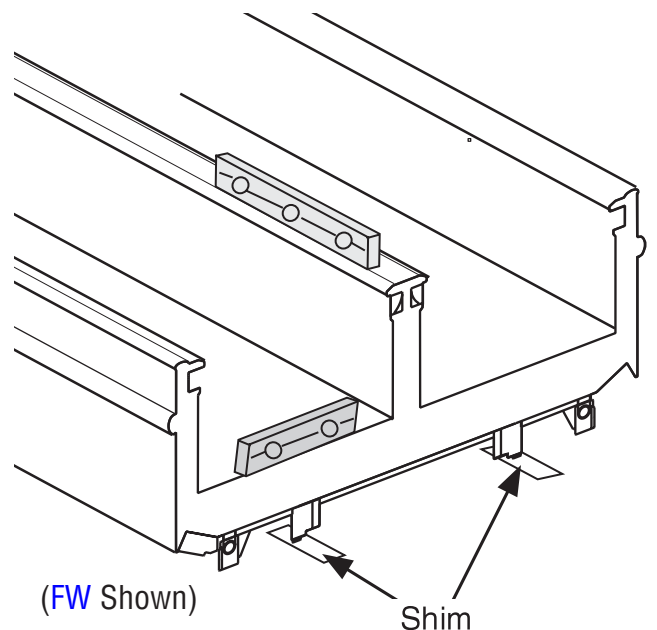

1-6 INSTALLATION

remove the fasteners holding the retainers for the discharge air louvers. (Lift louvers up and out from the bottom.) Remove any return air flue plex-glass parts. (Lift up on interior panels to remove.) See 1-14 for replacement. **NOTE:** **FWE** and **FWEG** end merchandisers have joining fasteners inserted in the appropriate locations. Remove nuts and washers from outside of end merchandiser before attempting to join.

**Apply Gaskets to Right End**

1. Apply the 1 5/8 in. (41 mm) gasket around the perimeter of the merchandiser as shown. It must be at the edge. Check to be sure that there are no gaps between gasket and merchandiser.

2. Apply the 1 in. (25 mm) gasket across the end shoe as shown. Each end of the gasket should extend onto the 1 5/8 inch gasket but not over. Check to be sure that there are no gaps between merchandiser and gaskets.

3. On narrow and intermediate islands, wall merchandisers, and cases, apply the 1 in. (25 mm) gasket at the top of the discharge and return air flues as shown. On wide islands, apply the 1 in. (25 mm) gasket at the top of return air flues as shown. Apply the 1 5/8 in. (41 mm) gasket at the top of the discharge (center) flue as shown.

**NOTE:** When adding an end merchandiser, apply gaskets to the wide island, not the end merchandiser.



**JOINING MERCHANDISERS IN LINE**

**IMPORTANT**

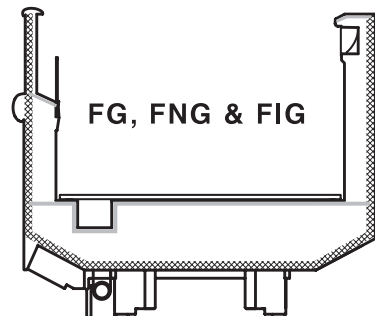
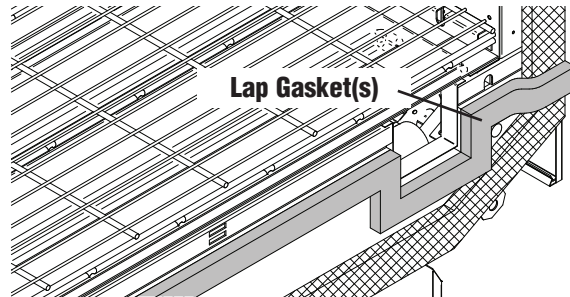

- Do not stretch gasket, especially around corners.
- Do not butt gaskets; always overlap them as shown.
- Remove paper backing after gasket has been applied.

• *Perimeter gasket is required by NSF.*

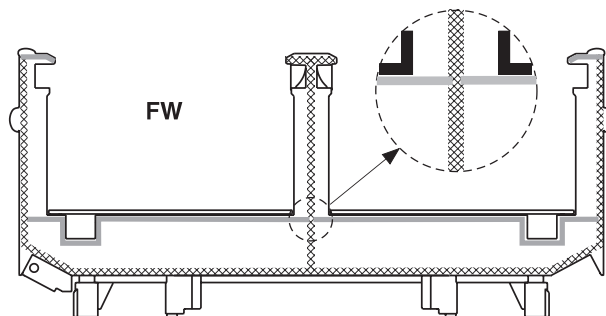

 1 5/8 x 1/2 Foam Gasket  
 1 x 1/2 Foam Gasket



 1 5/8 x 1/2 Foam Gasket  
 1 x 1/2 Foam Gasket

1. Remove and retain any factory-installed fasteners.

2. *Move merchandisers in lineup as close as possible by pushing or using lever bar (mule).*



**Verify alignment of panels, bumper retainer and top rail.**



3. Verify upper front panel, front panel, bumper retainer, and top rail alignment *before* joining merchandisers, and shim as necessary. Panels and Top Rail must have equal overhang at each end of merchandiser.

**Shim cases to ensure vertical alignment of panels and top rails.**

**Install fasteners (parent to parent).**

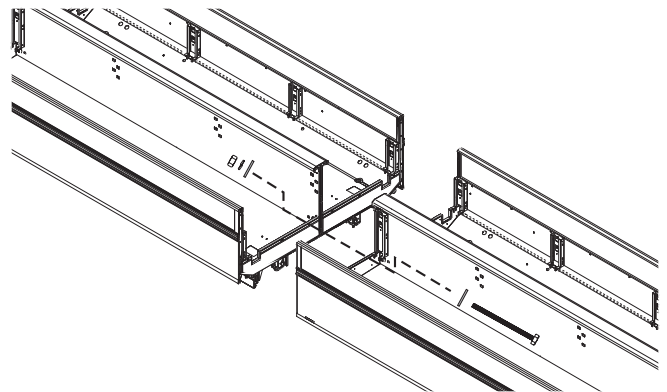

**NOTE:** Merchandisers must be leveled before joining. Verify all top rails, panels and bumper retainers of each merchandiser to be joined align vertically before joining.

*To correct vertical alignment of top rails and upper front panel, adjust shims as necessary.*

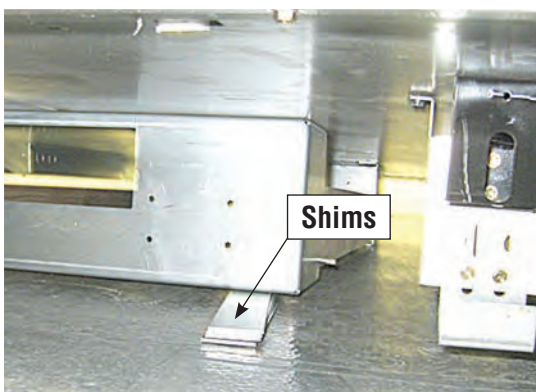

## 1-8 INSTALLATION

4. Align frame fasteners. **Fastener size and location are detailed on Pages 1-10 and 1-11.** Loosely assemble bolt, washers, lockwasher and nut as shown here.

**NOTE: Joining hardware is shown enlarged for clarity.**

For glass cases, remove nut retainer clips in one of the case's end frame for each pair of cases joined in the lineup.

**NOTE THAT ALIGNMENT ORDER IS DIFFERENT FROM TIGHTENING ORDER!**

**Do not attempt to draw merchandisers together using nut and bolt.**

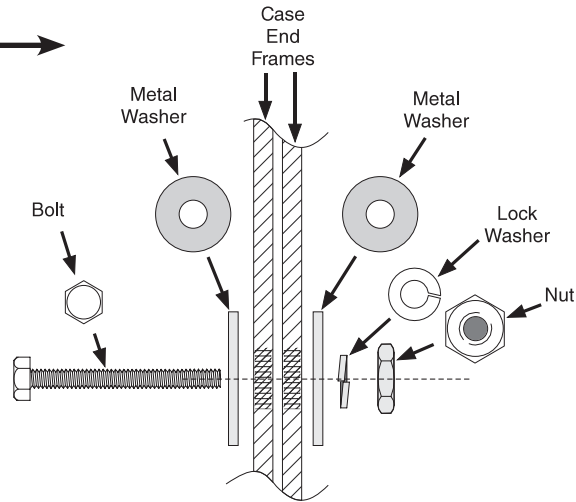

5. Secure H-shaped joining clip between merchandisers at center rail as shown. Lift plastic handrail if necessary.

**NOTE: H-shaped joining clip is not used when joining end merchandisers with stainless steel rails.**

**Bumper retainer design that allows for slight lateral movement for both solid and glass front merchandisers.**

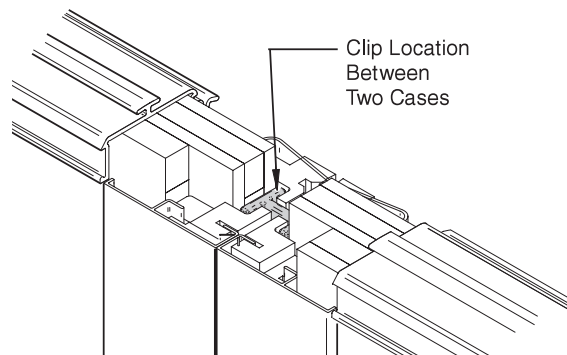

6. Join bumper retainers.

Joining brackets are installed in factory. Be sure to loosen joining bracket screws before tightening and joining the bumper brackets.

Tighten the screws of joining brackets after tightening the other screws according to Sequence 6A and 6B for **FW** cases on Page 1-13, and Sequence 8 and 9 for **FI** cases as shown on Page 1-13.

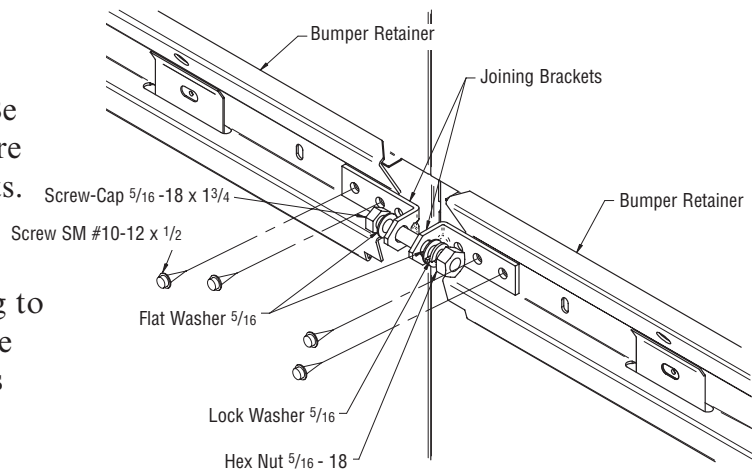

## JOINING END MERCHANDISER TO WIDE ISLANDS

**NOTE:** Merchandisers must be level before joining.

1. Remove nuts and washers from outside of end case.
2. Apply gaskets to wide island.
3. Move end as close to the wide island as possible by using lever bar (mule). Take care not to damage optional adjustable legs.

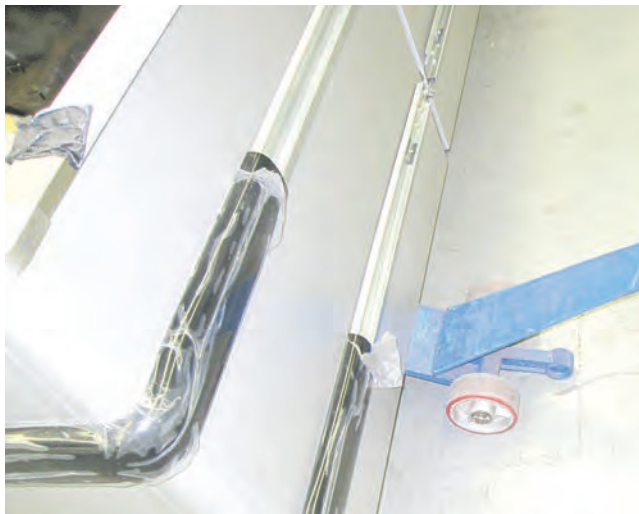

4. Verify upper front panel, front panel, bumper retainer, and top rail alignment *before* joining cases, and shim cases as necessary.

**NOTE:** Merchandiser must be leveled before joining. Verify all top rails, panels and bumper retainers of each merchandiser to be joined align vertically before joining.

To correct vertical alignment of top rails and upper front panel, adjust optional legs and, or shims as necessary.

**NOTE THAT ALIGNMENT ORDER IS DIFFERENT FROM TIGHTENING ORDER!**

Verify alignment of panels, bumper retainer and top rail.



Adjust (optional) legs or shim cases to ensure vertical alignment of panels and top rails.

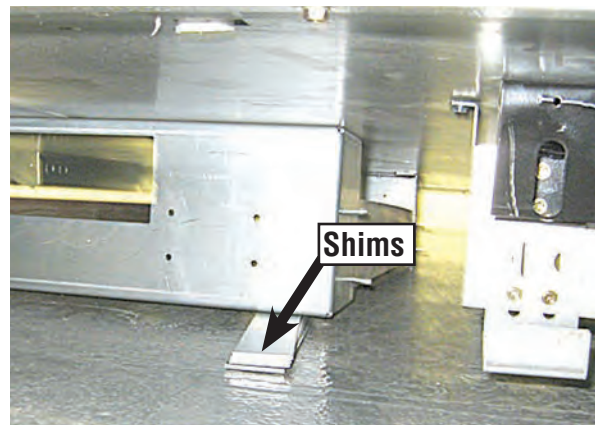

Install fasteners (parent to end).

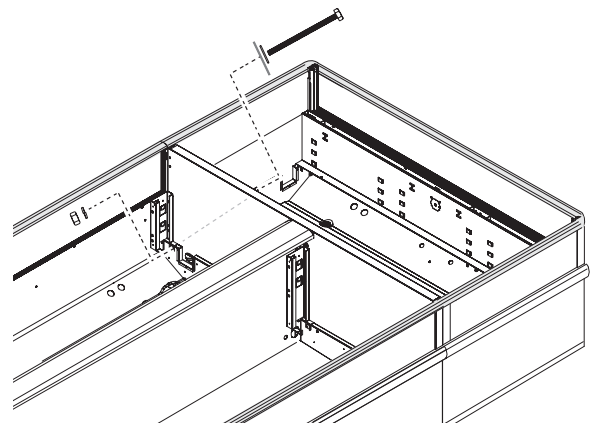

**1-10            INSTALLATION**

5. Align end case with wide island frame.  
**Fastener size and location are detailed in pages 1-12 and 1-13.** Loosely assemble bolt, washers, lockwasher and nuts as shown here.

**NOTE: Joining hardware is shown enlarged for clarity.**

**NOTE THAT ALIGNMENT ORDER IS DIFFERENT FROM TIGHTENING ORDER!**

**Do not attempt to draw merchandisers together using nut and bolt.**

**NOTE: H-Shaped Joining Clip is not used when joining end merchandisers with stainless steel rails.**

Bumper retainers allow for slight lateral movement for both solid and glass front merchandisers.

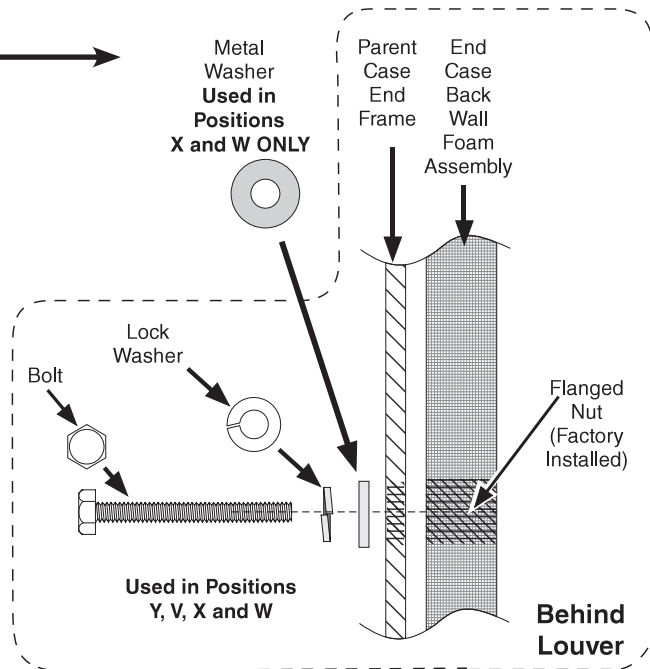

6. Join bumper retainers.

Joining brackets are installed in factory. Be sure to loosen joining bracket screws before tightening and joining the bumper brackets.

Tighten the screws of joining brackets after tightening the other screws according to Sequence 6A and 6B for **FW** cases on Page 1-13, and Sequence 8 and 9 for **FI** cases as shown on Page 1-13.

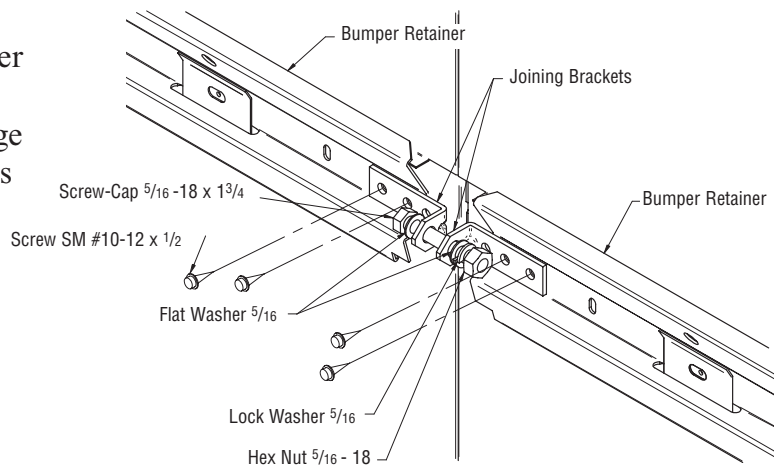

Parent to Parent Installation KEY:

- T — Center Flue End Cap Alignment Pin
- U — 5/16-18 X 1 3/4 in. Hex Head Screw
- V — 5/16-18 X 3 1/2 in. Hex Head Screw
- W — 5/16-18 X 1 3/4 in. Hex Head Screw
- X — (Used for End Case Only)
- Y — M6 - 1.0 X 25 mm Hex Head Screw
- Z — Joining Clip

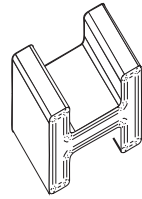

Joining Clip



Use a socket with a U-joint adjustable adapter to more easily tighten fasteners.

FW to FW

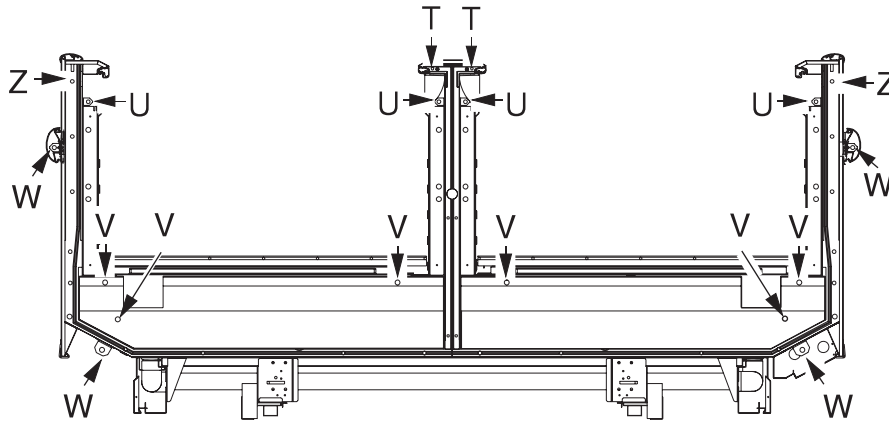

FWG to FWG

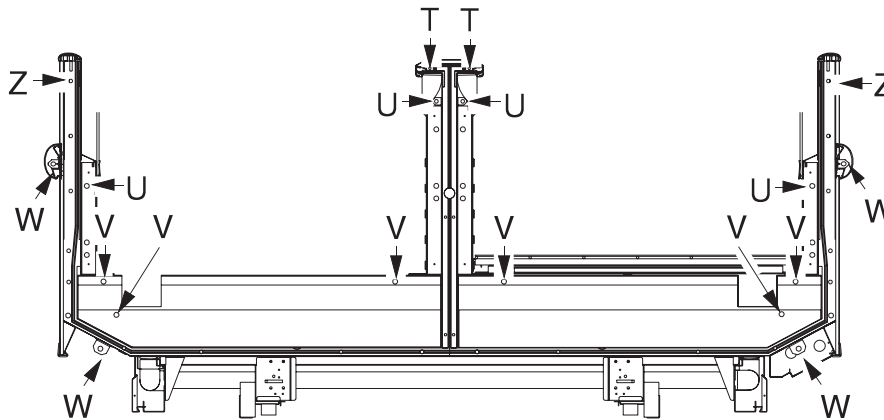

FWGH to FWGH

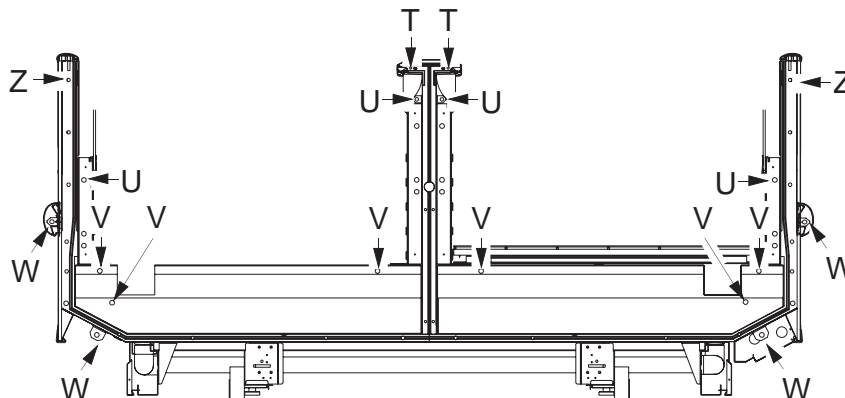

# 1-12 INSTALLATION

FI to FI

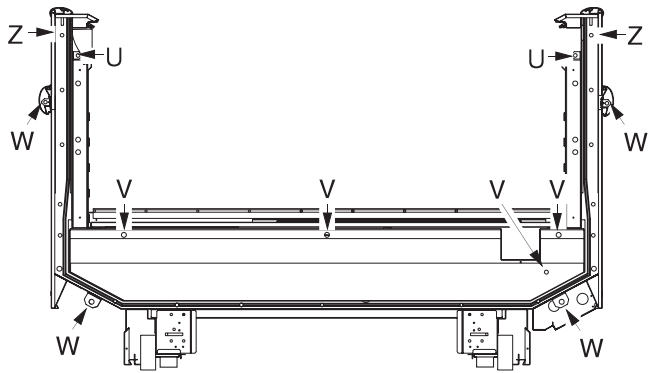
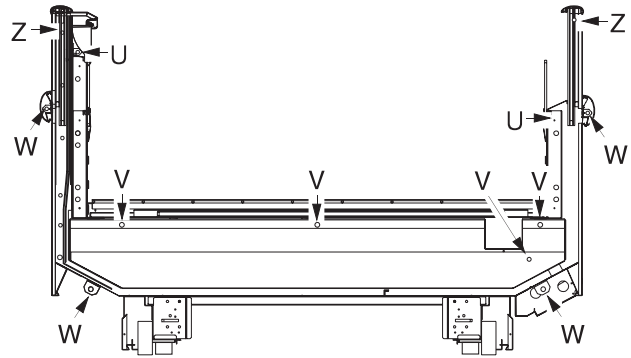
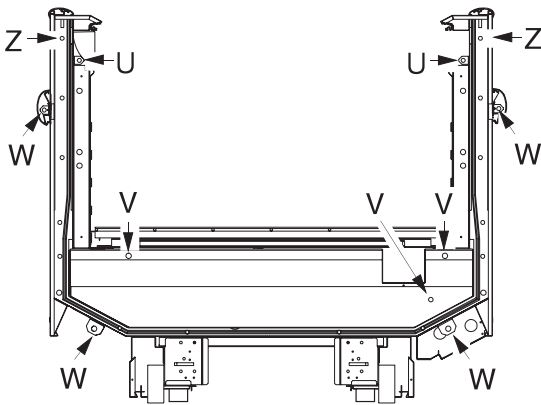

FIG to FIG



FN to FN



FNG to FNG

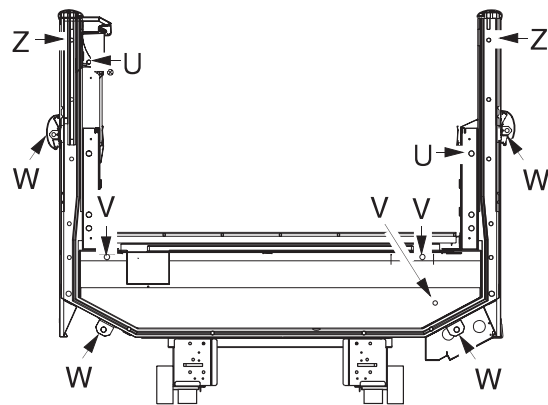

F to F

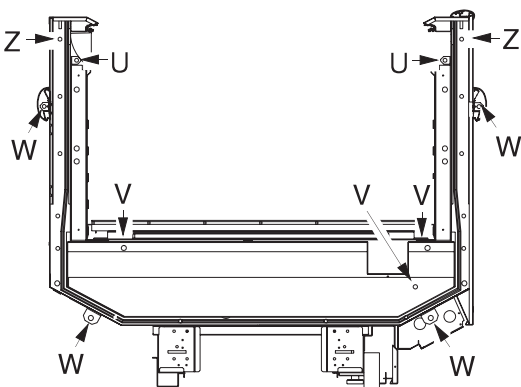

FG to FG

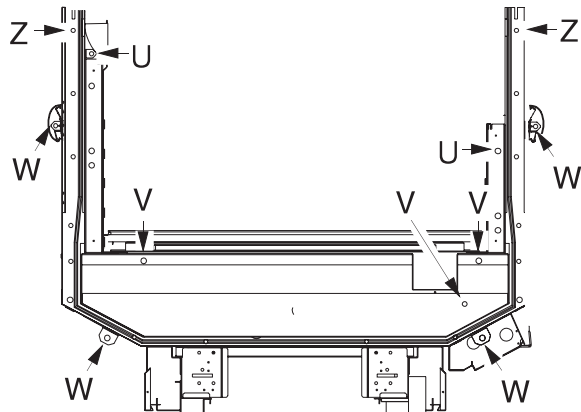

Parent to End Installation KEY:

- T — Center Flue End Cap Alignment Pin
- U — 5/16-18 X 1 3/4 in. Hex Head Screw
- V — 5/16-18 X 3 1/2 in. Hex Head Screw
- W — 5/16-18 X 1 3/4 in. Hex Head Screw
- X — 5/16-18 X 4 1/2 in. Tap Bolt
- Y — M6 - 1.0 X 25 mm Hex Head Screw
- Z — Joining Clip

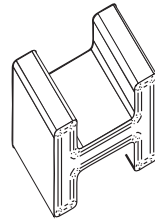

Joining Clip

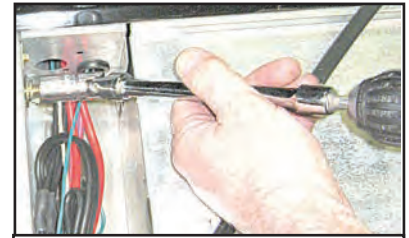

Use a socket with a U-joint adjustable adapter to more easily tighten fasteners.

FW to FWE

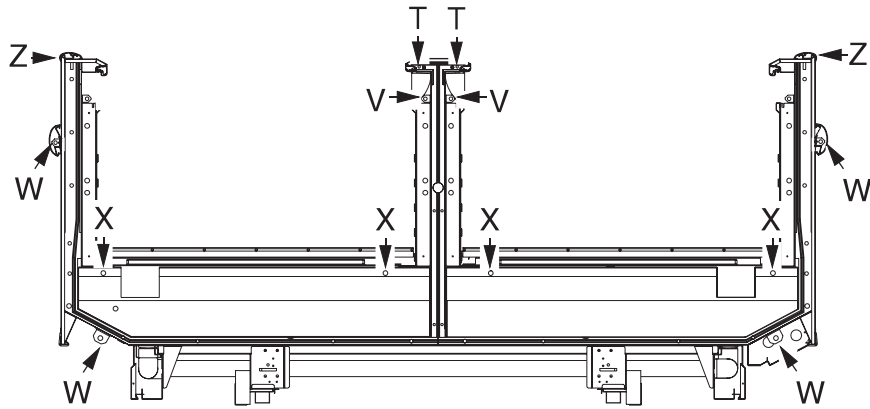

FWG to FWEG

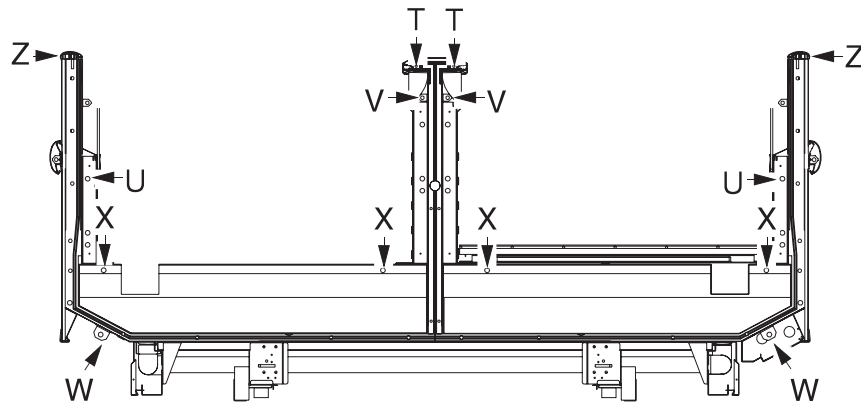

FWGH to FWEGH

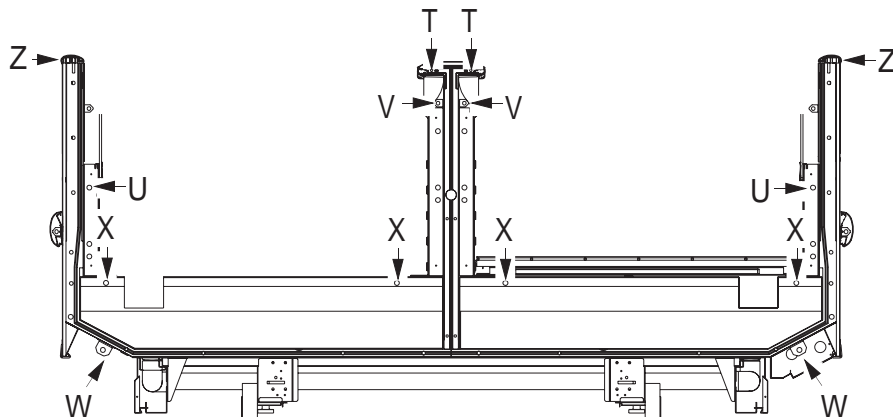

**Fasten End Frames**

1. Tighten joints in the order shown until gaskets are compressed, and merchandisers join smoothly. Work from the lower front to lower back to upper back. Fasten the upper front last.

When joining End merchandisers to Wide Islands, follow the joining order for the wide island, beginning with 1A and 1B.

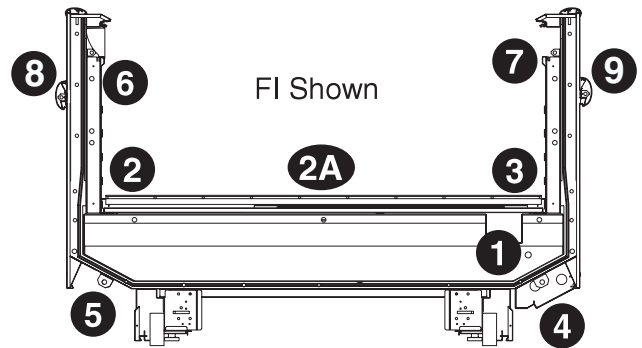

**Tighten in Order Shown**

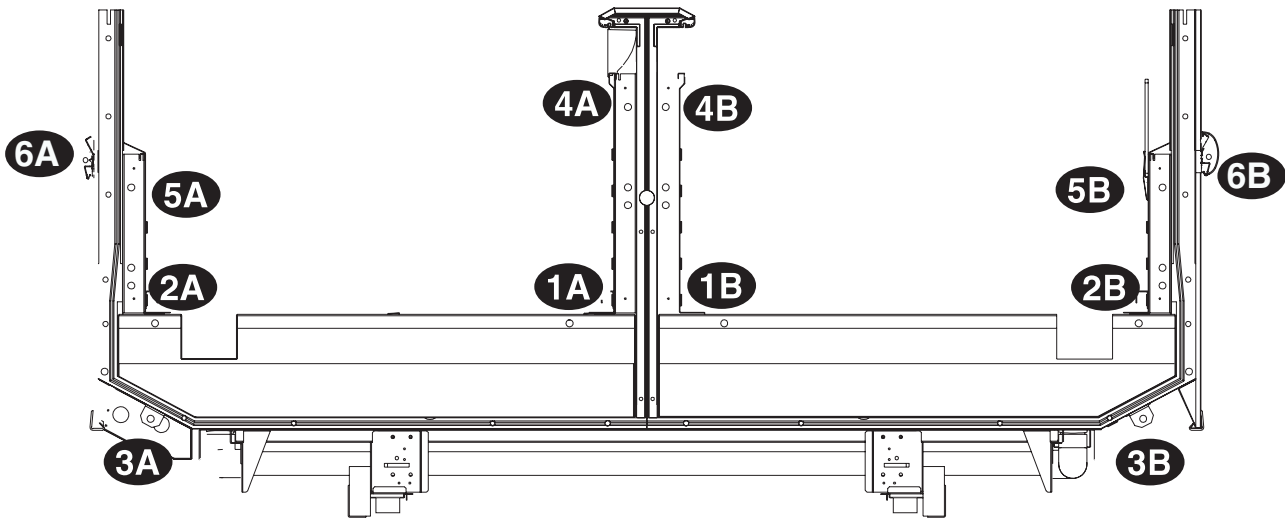

**Tighten in Order Shown**

**Seal Merchandisers**

1. Remove wire rack, rack supports and interior panels to apply butyl tape.

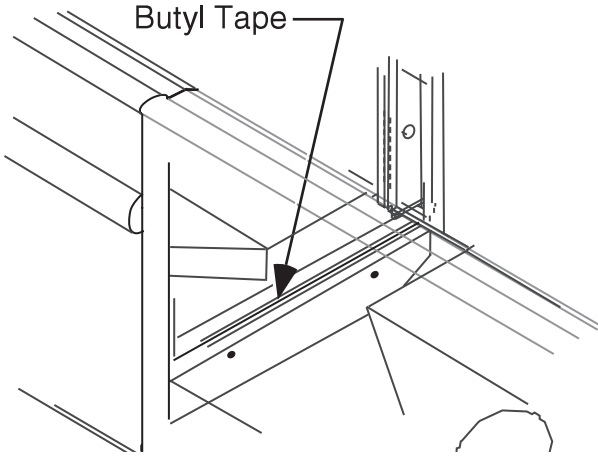

2. Apply butyl tape across the bottom joint. Be sure to extend the tape up the back and front of the merchandiser.

Silicone sealer may be applied around joining bolts on both sides in bottom shoe.

**INSTALLING SPLASHGUARD BRACKETS**

Position splashguard brackets to the merchandiser and level to the floor. Each bracket has a 1½ in. (38 mm) slot at the rear of the bracket where it attaches to the merchandiser. Tighten screws to secure the brackets.

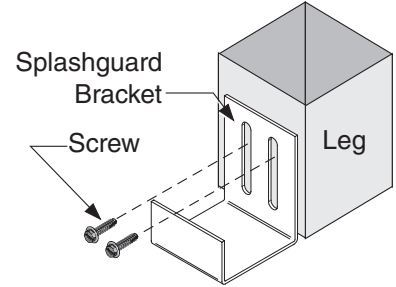

**Important:** Install splashguard brackets before installing drip piping.

**REPLACING INTERIOR PANELS AND DISCHARGE AIR LOUVERS**

After case joining is complete and all joining bolts are fastened, re-install the interior front and back panels. Special care needs to be taken when re-installing the discharge air louvers. The flange at the top of the louver must properly fit into the correct position in the extrusion. Incorrect position of the louver can cause the plastic nosing on the anti-sweat heater to become dislodged. See details in Section 6 for correct steps to re-install plastic nosing extrusion.

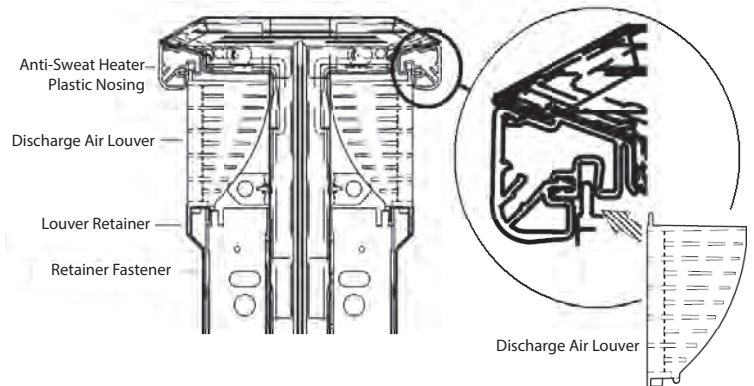

**OFFSETTING BUMPERS**

Offsetting the bumper helps to disguise the joint locations, giving the lineup a smoother look.

**Note: The Excel low temperature case BUMPERS ARE DIRECTIONAL. Look for an arrow inside the bumper.**

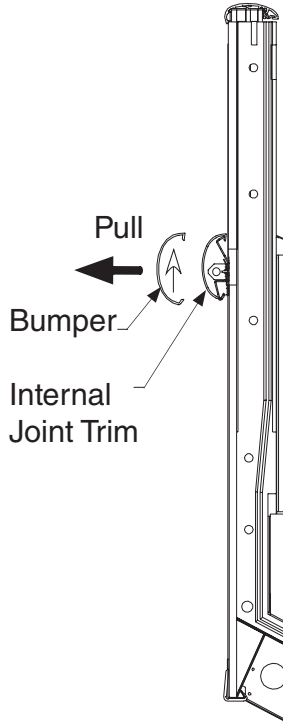

Place the padded pry bar below the bumper as shown below. The tape/padding lessens the chance of damaging the color panel.

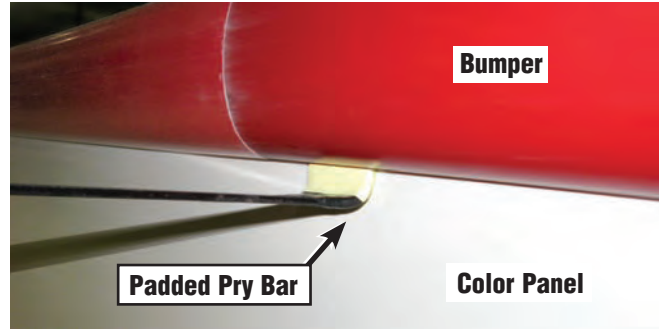

Do not use a screwdriver or other sharp object, which will damage bumper and color panel.



**DO NOT USE SHARP OBJECT**

**Bumper Removal**

Although bumpers can usually be removed by hand, a simple tool to remove bumpers can be created by wrapping tape over the claw of a small pry bar as shown here. The pry bar is available at most local hardware stores.



These merchandisers have sheet metal retainers with joining brackets. Bumper retainers may be removed, or adjusted by removing bumper, color panels and bumper retainer screws.

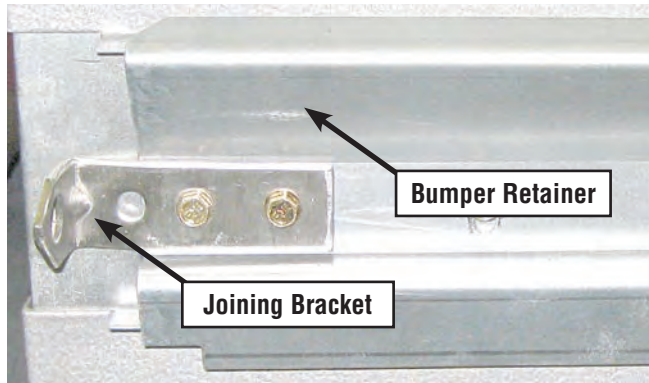

Prying on the long edges is likely to damage the retainer.



Cases with rubber bumper retainers may be removed by lifting the end as shown below.

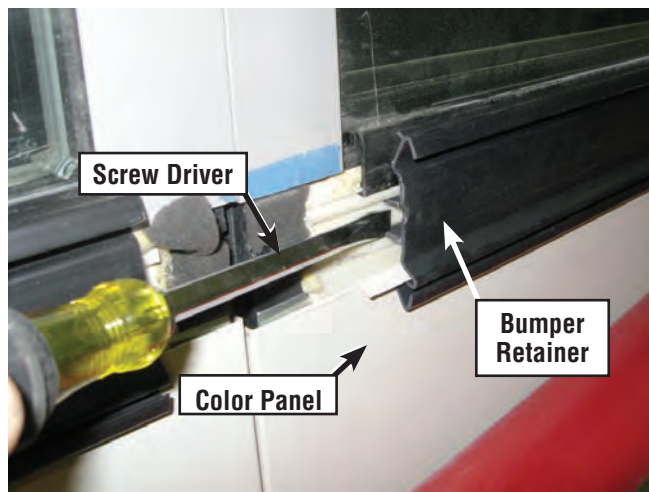

For merchandisers with rubber retainers and glass fronts, replace retainer as shown below using a scrap block of lumber and a rubber mallet. One person should hold the retainer in alignment while another taps it into place.

### Offsetting Bumper (for End Merchandisers)

1. Locate starter bumper shipped with the left-end kit.
2. Remove factory installed bumper by pulling bumper away from bumper retainer. Be careful not to lose the internal joint trim on the bumper.
3. Starting at the left end of the lineup, install the bumper starter section first. To install:
  - a. Position internal joint trims so that the first is flush to the left-end panel and the second is centered between the starter bumper and the full-length bumper as shown.
  - b. Install full-length bumpers and internal trims offset across joints. Make sure that no gaps exist between sections. Continue installing the bumpers the length of the lineup.

4. Once all except the last section of bumper have been installed, refrigerate the merchandiser lineup for at least six (6) hours. **The last section of bumper should be kept inside a cooler or refrigerated merchandiser during this time.** This will allow the bumper to contract.

5. Go to the right end of the lineup and tap the bumper to close any gaps.

6. Measure and cut last section of bumper. Use a miter box and fine-tooth saw to cut last bumper to length. Install the last section.

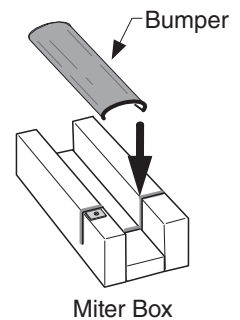

7. Remove protective film from bumper once installation is complete.

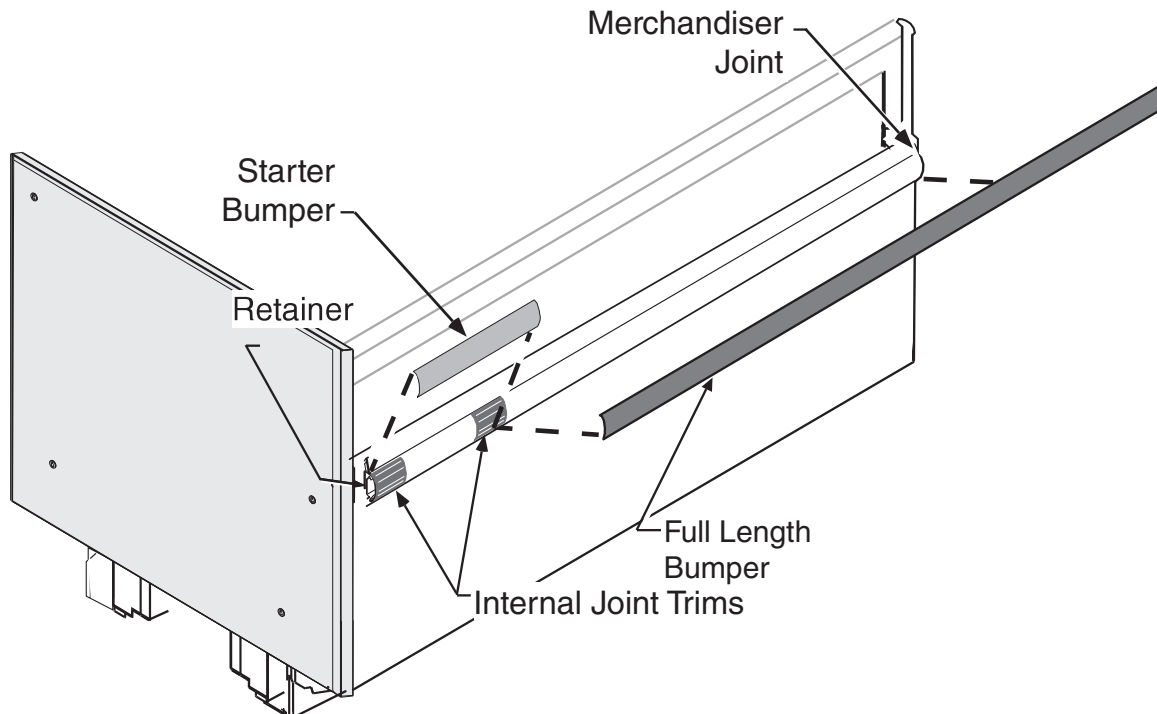

**Offsetting Bumper (for Merchandiser Lineup)**

1. Locate bumpers for the sides of the lineup. The bumpers are shipped with the merchandisers.
2. Refrigerate the merchandiser lineup for at least six (6) hours. **The offsetting bumpers sections should be kept inside a cooler or refrigerated merchandiser during this time.** This will allow the bumper to contract and provide for a good fit and finish.

3. To install offsetting bumpers:

- a. Remove bumpers from cooler. Measure bumpers and cut to appropriate length. Use a miter box and fine-tooth saw.

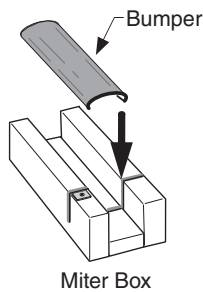

- b. Insert internal joint trims first. Install bumpers offset across joints along the side of the lineup as shown in the illustration below. Joint trim provides stability for the bumpers, and lends to a smooth fit and finish.

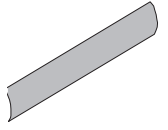

4. Make sure no gaps exist between sections at each end of field cut bumpers.
5. Verify fit and finish at both sides of corner extrusion. If bumpers are cut too long, the corner extrusion may bow out, resulting in an unattractive finish.
6. Remove protective film from bumper once installation is complete.

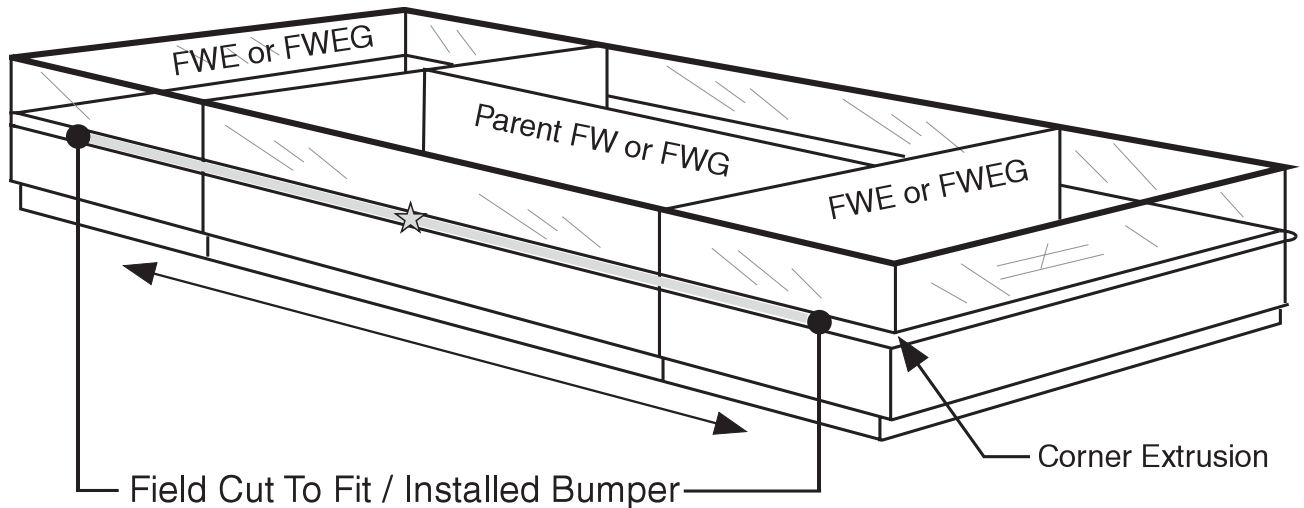

## OFFSETTING PLASTIC TOP RAIL

Offsetting the plastic top rail helps to disguise the joint locations, giving the lineup a smoother look.

**If factory installed,** carefully remove all plastic top rails in the lineup. Do not damage the top rail retainer.

1. Refer to ① in illustration below. Install a 1-ft starter section flush against the corner trim at the left end of the lineup.
2. Refer to ② in illustration below. Re-install a 38-inch section removed earlier from the end merchandiser. Place it flush against the starter, without any gaps.
3. Refer to ③ in illustration below. Install a full-length top rail, leaving no gaps. Continue installing the top rails the length of the lineup.

4. Once all except the last section of top rail have been installed refrigerate the merchandiser lineup for at least six (6) hours. **The last section of top rail should be kept inside a cooler or refrigerated merchandiser during this time.** This will allow the top rail to contract.

5. Go to the right end of the lineup and tap the top rail to close any gaps.

6. Refer to ④ in illustration below. Measure and cut last section of top rail. Use a miter box and fine-tooth saw to cut last top rail to length. Install the last section.

7. Remove protective film from top rail once installation is complete.

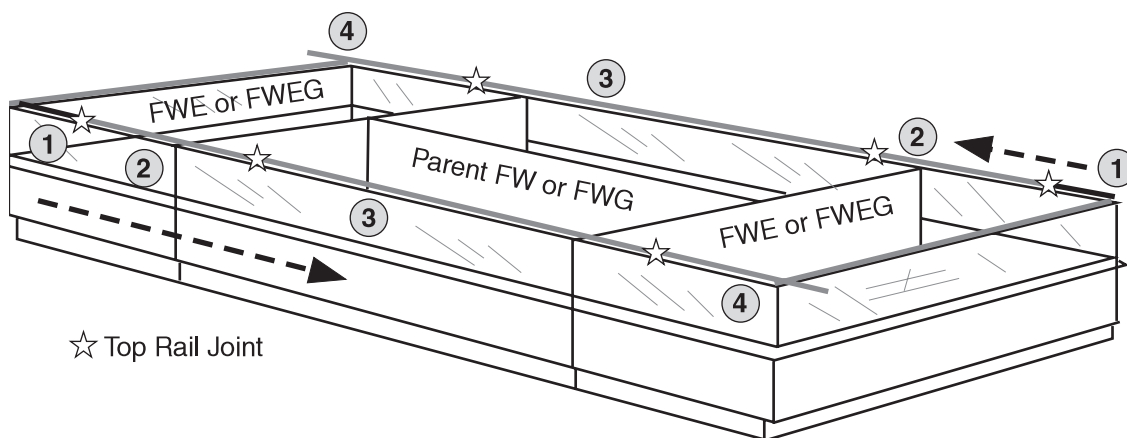

**If top rails are not factory installed,**

1. Begin by installing a 48-inch top rail against the corner trim of the LH end case. Refer to ① in the illustration below.
2. Install a second 48-inch top rail against the corner of the RH end merchandiser. Refer to ② in the illustration below.
3. Once all except the last section of top rail have been installed refrigerate the merchandiser lineup for at least six (6) hours. **The last section of top rail should be kept inside a cooler or refrigerated merchandiser during this time.** This will allow the top rail to contract.
4. Tap the top rail to close any gaps.
5. Measure the center section, ③ in illustration below, and cut Top Rail to fit. Use a miter box and fine-tooth saw to cut last top rail to length. Install the last section.
6. Remove protective film from top rail once installation is complete.

**OPTIONAL STAINLESS STEEL TOP RAIL**

Stainless steel top rails are not offset. Install trim at each joint as indicated below.

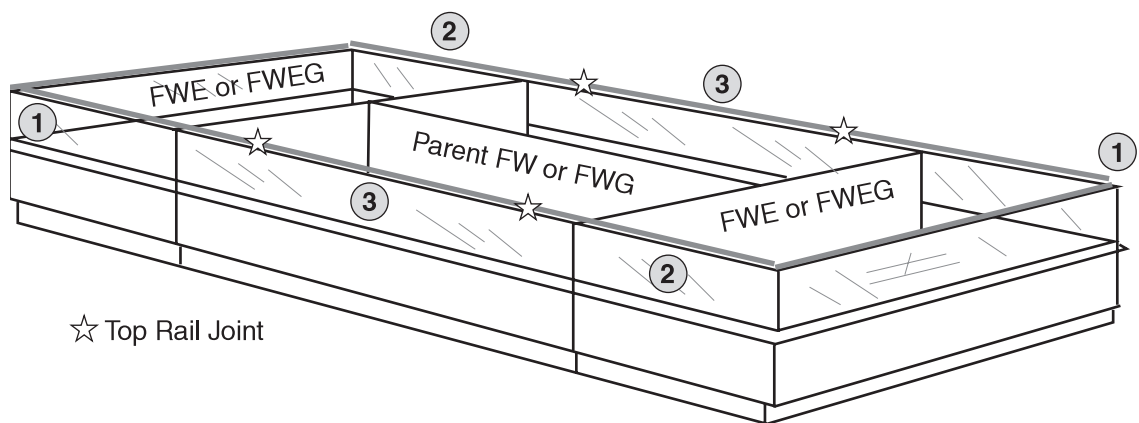
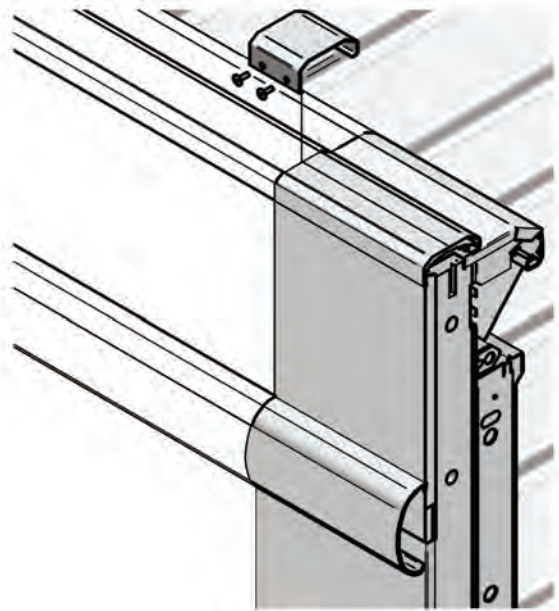

**INSTALLING FLUE GLASS — FNG & FIG**

The louvers, flue glass, retainer and brackets are shipped loose and must be installed before the lineup can be started up.

1. Apply flue glass Retainer to the top of each section of flue glass.
2. Position the glass in the merchandiser.
3. Slide a Discharge Deflector Bracket into each bend of the and into the flue glass retainer.

**INSTALLING FLUE GLASS CLAMP (FWGH & FWEHG)**

The flue glass retainer is installed as shown below. Insert supplied bolts (4) through retainer, Bolts fasten into factory-installed nut retainers.

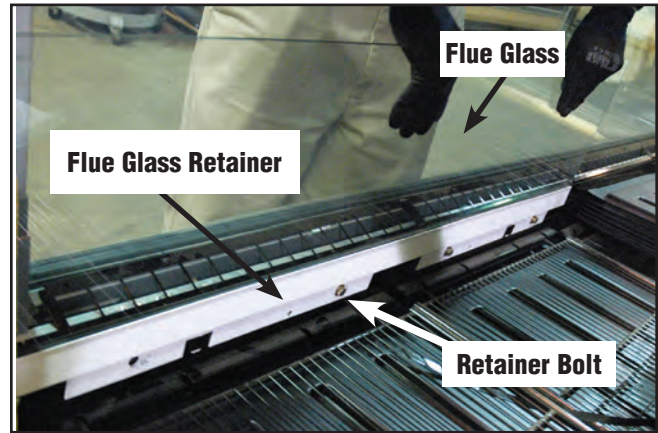
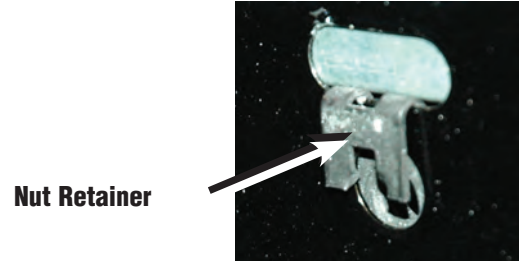
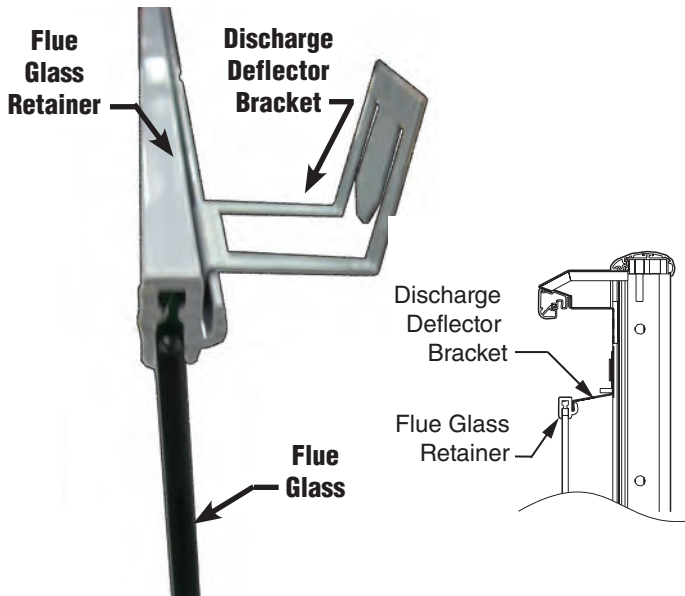

The flue glass is packed inside of the case. Remove the packaging, and slide flue glass securely into top lip of flue glass retainer. Fasten (4) bolts into nut retainers (7f lbs). DO NOT over-tighten bolts.

**INSTALLING PARTITIONS**

To join same temperature fixtures on different defrost cycles, an acrylic partition kit is required.

To join unlike fixtures, or like fixtures operating at different temperatures, an insulated partition kit is required. It must be installed when setting the lineup. Instructions for installing these partitions are included with the kits.

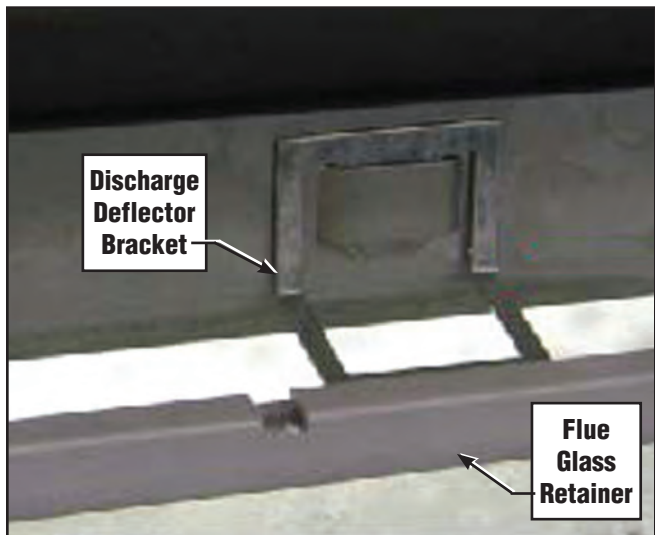

## INSTALLING END ASSEMBLIES

End assemblies are normally factory installed. The following information is provided for retrofit or field installation.

### 1. Prepare Merchandiser

- a. Remove display racks, pans, front rack supports and front air grilles from section of case where end is to be installed.
- b. Remove the interior back panel. No tools required.

### 2. Apply gaskets to end frame

### 3. Fasten End Assembly to Merchandiser

- a. Use Bolt and washer to fasten end assembly to merchandiser in the same way the end merchandiser is fastened.
- b. Tighten in order shown for joining.

### 4. Seal End to End Frame

Remove front shelf and shelf support bracket. Apply a 1/2 in. bead of Silicone at the back of the case, starting at the first slot. Continue across the bottom and up the front as shown below. Use field-supplied silicone in any gap between front support bracket and end assembly.

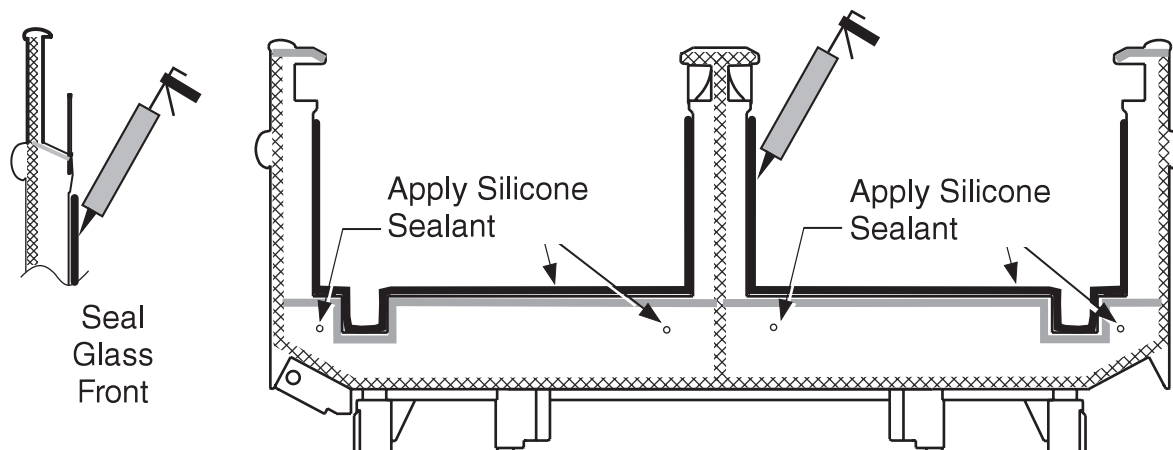

**Re-install bumpers as described beginning on Page 1-14.**

### 5. Install End Splashguard Bracket

Insert back of bracket through slot in leg. Use Screws to attach End Splashguard Retainer to end frame.

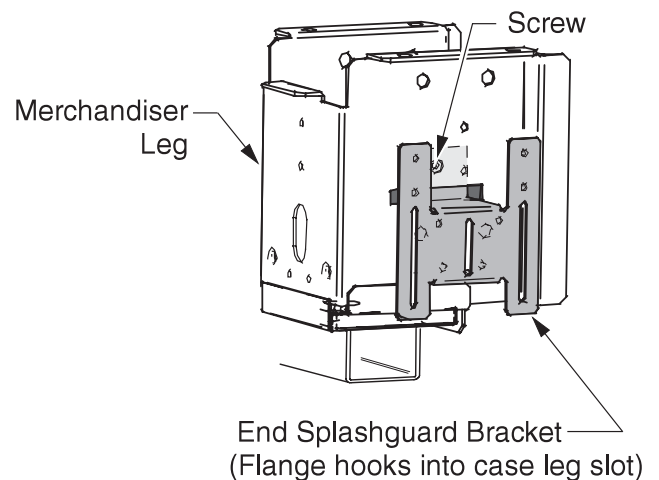

NOTES:

## REFRIGERATION / ELECTRICAL

### REFRIGERANT

The correct type of refrigerant will be stamped on each merchandiser's serial plate. The merchandiser refrigeration piping is leak tested, factory sealed and pressurized. Before making refrigeration hookups, depress the universal line valve to ensure that coils have maintained pressure during shipment. When using high glide refrigerants (e.g., R-407A, R-448A), if superheat needs to be adjusted, use the evaporator pressure and subtract the dew point from the coil outlet refrigerant temperature to measure the superheat level.

### WARNING

**Refrigerant vapor is hazardous to your health and can cause death.**

**Avoid breathing refrigerant and lubrication vapor or mist. Exposure may irritate eyes, nose and throat. If accidental system discharge occurs, ventilate work area before resuming service.**

**Always wear safety goggles and protective gloves when working with refrigerants. Contact with refrigerant may cause injury. Disconnect hoses with extreme caution! All hoses may contain liquid refrigerant under pressure.**

**Be sure that any room where you are working is thoroughly ventilated, especially if a leak is suspected.**

**Read all safety information regarding the safe handling of refrigerant and refrigerant oil, including the Material Safety Data Sheet. MSDS sheets can be obtained from your refrigerant supplier.**

**Refrigeration lines are under pressure and should be depressurized before attempting to make any connections.**

### REFRIGERANT PIPING

#### Connection Location

The refrigerant line connections are at the right-hand end of merchandiser (end opposite the main serial plate) beneath the display pans. A sticker marks the location of the connection. The installer must saw a hole to exit the cases.

A refrigeration shroud ships with each case. Before making connections, place the refrigeration shroud over refrigeration piping so that when the shroud is rotated into place, it will be in the upright position. The Figure 2-1 shows the correct orientation.

Be careful not to burn, scorch or overheat the shroud when making connections. Once connections have been made, apply silicone sealant to the bottom of the shroud as shown in Figure 2-2.

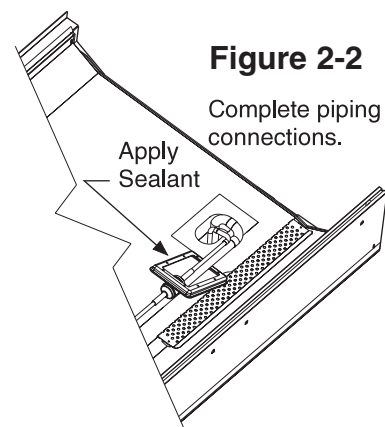
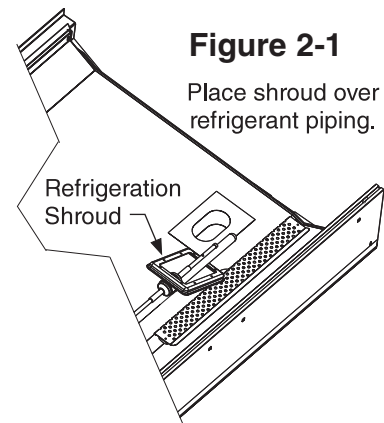

As shown in Figure 2-3, rotate and center the shroud over the refrigeration outlet foam pad, then fasten to the interior liner of the bottom.

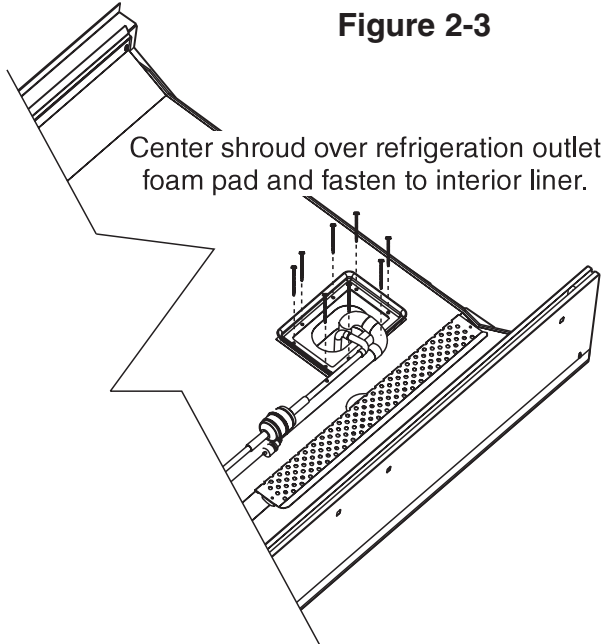

After connections have been made, seal this outlet thoroughly. Seal both the inside and the outside. We recommend using an expanding polyurethane foam insulation. Cover foam with silicone to prevent water from entering foam.

### Multiplexing

Piping of merchandisers operating on the same refrigeration system may be run from case to case. **DO NOT RUN REFRIGERANT LINES THROUGH MERCHANDISERS THAT ARE NOT ON THE SAME REFRIGERATION SYSTEM BRANCH** as this may result in poor refrigeration control and compressor failure.

Interconnecting piping inside the merchandiser must be located as shown below for clearance beneath the display pans. Alternately, the interconnecting piping may be run outside the case in the area shown.

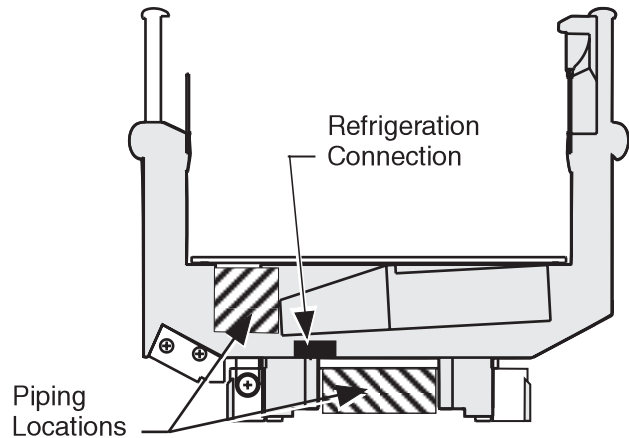

### Line Sizing

Refrigerant lines should be sized as shown on the refrigeration legend that is furnished for the store or according to ASHRAE guidelines.

**Note:** If Koolgas defrost is used, the liquid line will need to be increased two sizes larger inside the merchandiser area. This is necessary to ensure even liquid drainage from all evaporators during defrost.

### Oil Traps

P-traps (oil traps) must be installed at the base of all suction line vertical risers.

### Pressure Drop

Pressure drop can rob the system of capacity. To keep the pressure drop to a minimum, keep the refrigerant line run as short as possible using a minimum number of elbows. Where elbows are required, USE LONG RADIUS ELBOWS ONLY.

**INSULATION**

**With GAS Defrost**

The suction and liquid lines should NOT contact each other and should be insulated separately for a minimum of 30 ft (9144 mm) from the merchandiser.

**With OTHER Than Gas Defrost**

The suction and liquid lines should be clamped or taped together and insulated for a minimum of 30 ft (9144 mm) from the merchandiser.

**With EITHER of Above**

Additional insulation for the balance of the liquid and suction lines is recommended wherever condensation drippage is objectionable or the lines are exposed to ambient conditions.

**ATTENTION:**  
 The following information is applicable only for piping Hussmann merchandisers to Hussmann refrigeration equipment.

**BRANCH LINE PIPING**

**Suction Line – All Defrosts**

- Pitch in direction of flow.
- May be reduced by one size at one third of merchandiser run load and again after the second third. Do NOT reduce below evaporator connection size.
- Suction returns from evaporators enter at the top of the branch line.

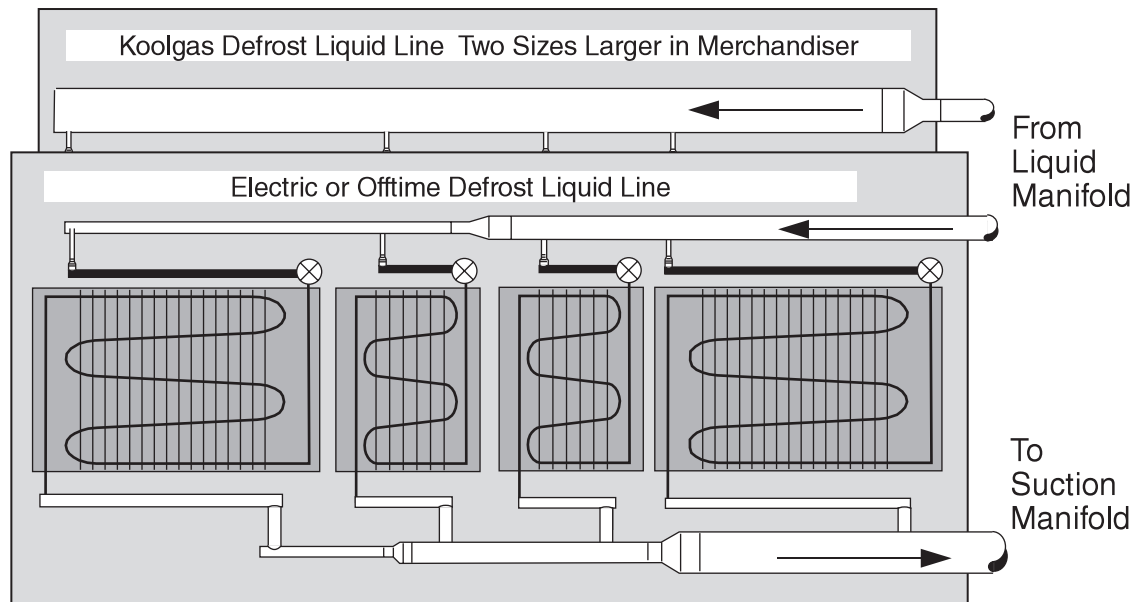

**Liquid Line – Off-time and Electric Defrost**

- May be reduced by one size after one half the merchandiser load run. Do not reduce below evaporator connection size.
- Take-offs to evaporators exit the bottom of the liquid line. Provide an expansion loop for each evaporator take-off (minimum 3 in. (76 mm) diameter).

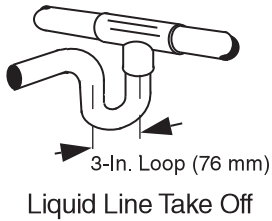

**Liquid Line – Koolgas Defrost**

- Maximum of 6 evaporators per Branch System.
- Increase the liquid line size inside the case by two sizes over the branch size.

Branch Size	In Merchandiser Size
1/2	7/8
5/8	1 1/8
7/8	1 3/8
1 1/8	1 5/8
1 3/8	2 1/8

- Take-offs to evaporators exit the bottom of the liquid line. Provide an expansion loop for each evaporator take-off (minimum 3 in. (76 mm) diameter).

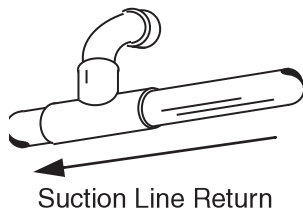

## FRONT TO REAR AND/OR END INTERCONNECTS

The wide island merchandisers are factory equipped with separate piping and air systems for each compartment, and are thus all capable of twin-temperature operation. This is a standard feature.

If the wide island merchandiser is to be run at a single temperature, factory installed piping interconnect kits are available.

### NOTE:

A *Dual Temperature Kit* adds components to allow a low temperature merchandiser to operate at medium temperatures, and switch between low and medium temperature operating conditions.

*Twin Temp* is used on low temperature wide island cases only and is the standard configuration. Twin temp means each side of the island operates separately; thus one side might be set for ice cream conditions while the other side could be set for frozen food or ice cream.

Only when both sides of a wide island lineup will always be used for the same operating conditions, should an interconnect piping kit be considered. Interconnect piping kits cannot be used with dual temperature kits. Contact Hussmann for further information.

## REFRIGERATION THERMOSTAT

The refrigeration thermostat body is located in the electrical wireway. The bulb, when factory installed, is located in the discharge flue. Wide Island models will have two thermostats – one on each side of the merchandiser.

## DEFROST TERMINATION THERMOSTAT

The standard disc type defrost termination thermostat is not adjustable. This thermostat is clamped to the coil inlet tube.

## CDA SENSOR (OPTIONAL)

Factory installed optional CDA sensor is located where the thermostat bulb would normally be located. Its leads will be routed through the electrical wireway and to the rack control panel. Leads are tagged in the wireway. Wide Island models will have two sensors—one on each side of the merchandiser.

**MERCHANDISER ELECTRICAL DATA**

Technical data sheets are included with this manual. The data sheets provide merchandiser electrical data, electrical schematics, parts lists and performance data. Refer to the technical data sheets and merchandiser serial plate for electrical information.

**FIELD WIRING**

Field wiring must be sized for component amperes stamped on the serial plate. Actual ampere draw may be less than specified. Field wiring from the refrigeration control panel to the merchandisers is required for defrost termination thermostats and for optional refrigeration thermostats. When multiple merchandisers are on the same defrost circuit, the defrost termination thermostats are wired in series.

**ALWAYS CHECK THE SERIAL PLATE FOR COMPONENT AMPERES.**

**ELECTRICAL CONNECTIONS**

All wiring must be in compliance with NEC and local codes. All electrical connections are to be made in the electrical wireway or *Handy Box*.

**IDENTIFICATION OF WIRING**

Leads for all electrical circuits are identified by colored plastic bands. These bands correspond to the *color code sticker* (shown below) located inside the merchandiser’s wireway cover.

The defrost heaters, defrost termination thermostats and refrigeration thermostats on the wide island models are tagged with identification as being either front or rear merchandiser display section defrost and refrigeration controls.

**WIRING COLOR CODE**

**Leads for all electrical circuits are identified by a colored plastic band: neutral wire for each circuit has either White insulation or a White plastic sleeve in addition to the color band.**

<b>PINK .....</b>	<b>REFRIG. THERMOSTAT LOW TEMP.</b>	<b>ORANGE OR</b>
<b>LIGHT BLUE...</b>	<b>REFRIG. THERMOSTAT NORM TEMP.</b>	<b>TAN.....LIGHTS</b>
<b>DARK BLUE...</b>	<b>DEFROST TERM. THERMOSTAT</b>	<b>MAROON.....RECEPTACLES</b>
<b>PURPLE .....</b>	<b>CONDENSATE HEATERS</b>	<b>YELLOW .....</b>
<b>BROWN .....</b>	<b>FAN MOTORS</b>	<b>RED .....</b>
<b>GREEN* .....</b>	<b>GROUND</b>	<b>DEFROST HEATERS 120V</b>
		<b>DEFROST HEATERS 208V</b>

**\*EITHER COLORED SLEEVE OR COLORED INSULATION**

**ELECTRICIAN NOTE: Use copper conductor wire only.  
CASE MUST BE GROUNDED**

### DRIP PIPING AND SPLASHGUARDS

#### WASTE OUTLET AND WATER SEAL

Each merchandiser has two waste outlets. The waste outlets are located in front of the fan plenum 12 inches (305 mm) from either end of the merchandiser.

Depending on the model, tees with clean-outs, or elbows, are supplied for each merchandiser. One water seal is supplied for each merchandiser. The water seal must be installed with the waste outlets to prevent air leakage and insect entrance into the merchandiser.

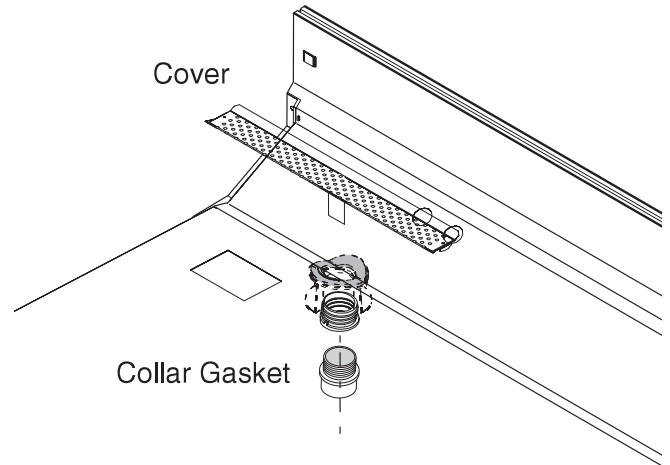

Items Factory Installed for Excel Waste Outlet on Each End of Case

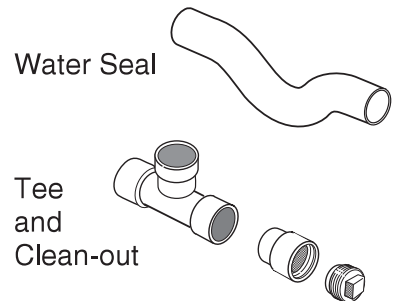
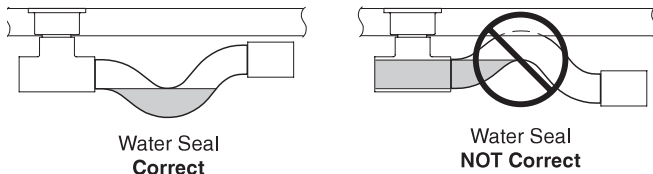

Factory Furnished Items To Be Installed

**NOTICE**

**Splashguard brackets MUST be installed before piping merchandiser.**

## INSTALLING DRIP PIPING

Poorly or improperly installed drip pipes can seriously interfere with the merchandiser's operation and result in costly maintenance and product losses.

Optional drip pipe arrangements are shown on the next page. Assemble the components using PVC specific threaded pipe sealer according to the manufacturer's direction.



...ATTENTION  
INSTALLER

**It is the installing contractor's responsibility to consult local agencies for local code requirements.**

Please follow the recommendations listed below when installing drip pipes to ensure proper installation.

1. Never use drip piping smaller than the nominal diameter of the pipe or water seal supplied with the merchandiser.
2. When connecting drip piping, the *water seal* must be used as part of the drip piping to prevent air leakage or insect entrance. Never use two water seals in series in any one drip pipe. **DOUBLE WATER SEALS IN SERIES WILL CAUSE AN AIR LOCK AND PREVENT DRAINING.**
3. Pitch the drip piping in the direction of flow. **There should be a minimum pitch of 1/4 in. per ft (20 mm per 1 m).**

4. Avoid long runs of drip piping. Long runs make it impossible to provide the pitch necessary for good drainage.

5. Ensure that drip piping is supported to relieve any stress on drip pipe connectors and drain hub.

a. Drip piping **MUST** be supported 24 inches from drain hub tee.

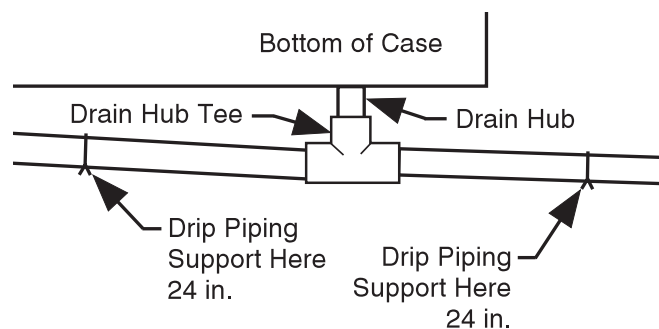

6. Provide a suitable air break between flood rim of the floor drain and outlet of drip pipe. To meet code requirements, it may be necessary to install a field-supplied drip pipe reducer. An alternative is to cut the last section of drip pipe at an angle.



7. Prevent drip pipes from freezing:

a. Do NOT install drip pipes in contact with uninsulated suction lines. Suction lines should be installed with a nonabsorbent insulation material.

b. Where drip pipes are located in dead air spaces, such as between merchandisers or between a merchandiser and a store wall, provide means to prevent freezing.

### DRIP PIPING LINEUP ARRANGEMENTS

The following illustrations below show typical arrangements for installing drip pipes for a lineup of merchandisers. Illustrations are for reference only. Piping may vary with location and access to hub drain(s). Each merchandiser waste outlet must be individually piped to a hub drain if 1/4 in. drip piping pitch cannot be maintained.

**NOTE:** No more than two merchandisers are to be piped per water seal. Do not install water seal between two merchandiser waste outlets that are piped together. **(Double water seals in series will cause an air lock and prevent drainage.)**

#### Optional Excel Drip Piping Arrangements

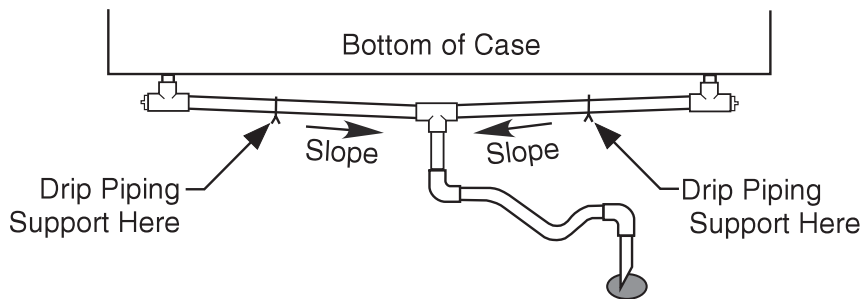

**IT IS THE INSTALLING CONTRACTOR'S RESPONSIBILITY TO PROVIDE SUITABLE DRAINAGE.**

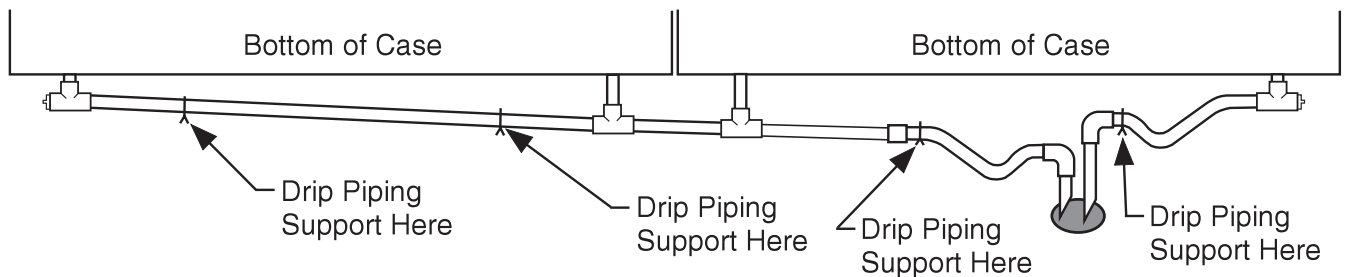

One Water Seal per Run of Drip Pipe  
Always Slope Toward Floor Drain

### INSTALLING SPLASHGUARDS

The splashguard is shipped inside each merchandiser. **AFTER** merchandisers have been leveled and joined, and all drip piping, electrical and refrigeration work has been completed, install the splashguard. End splashguards are addressed on the next page.

#### To Install Splashguards:

1. Check to be sure that all splashguard brackets are level with the floor.
2. Position top of splashguard with the top angled in as shown in the illustration. Align the slots in the upper edge of the splashguard with the tabs extending downward behind the splashguard cover.
3. Engage the slots over the tabs and raise the splashguard while pushing the bottom in.
4. Align the tabs on the splashguard brackets with the slots in the bottom edge of the splashguard. Engage the tabs in the slots and drop the splashguard into place.

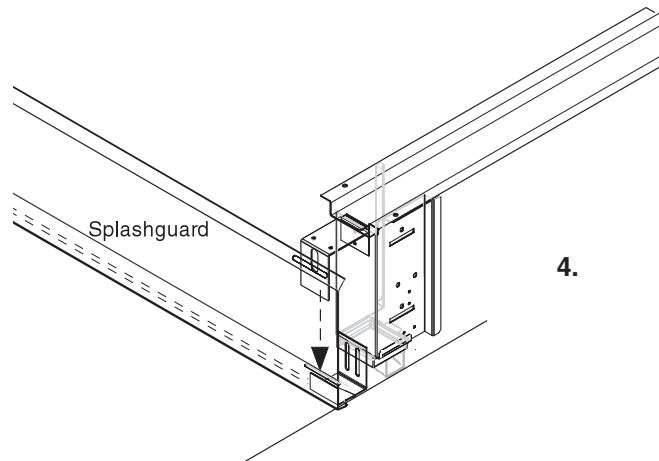
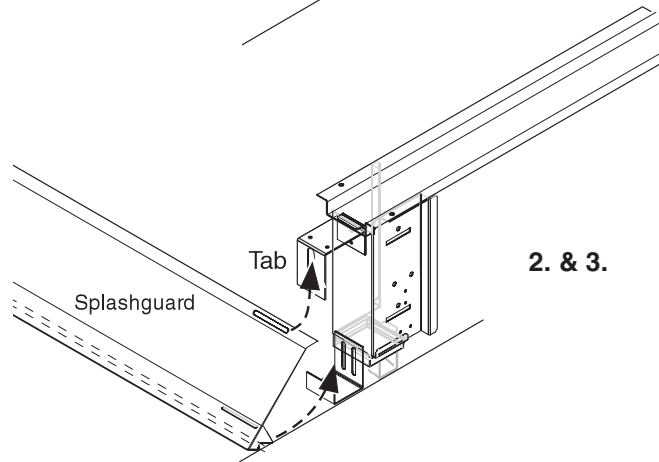
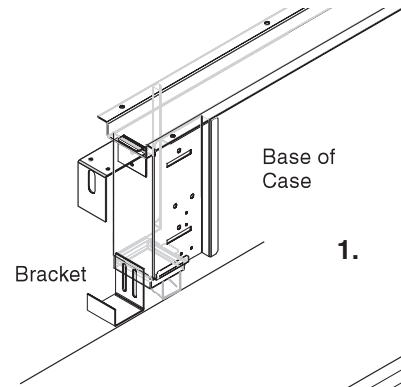

**To install the cove trim to the splashguard:**

1. Remove all dirt, wax and grease from the area of the splashguard where adhesion will be necessary to ensure a secure installation.
2. Apply a good contact cement to the cove trim and allow proper drying time according to the directions supplied with the cement.
3. Install the trim to the splashguard so that it is lying flush with the floor. **DO NOT SEAL THE TRIM TO THE FLOOR.**
4. **If required by local health codes** the Cove Trim may be sealed to the floor, using a silicone type sealer. Sealant must be removed and replaced when servicing.

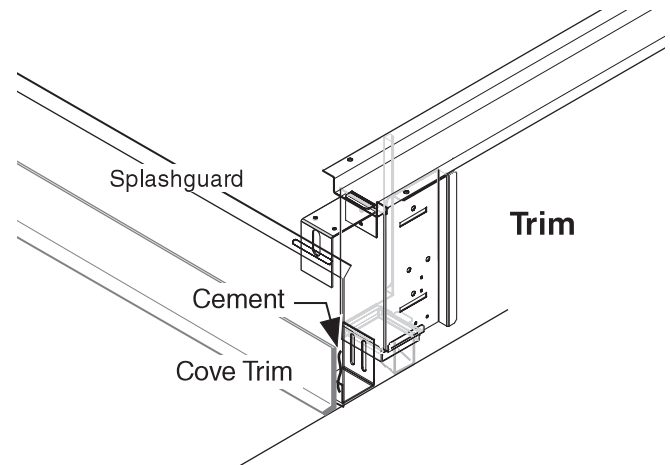

**Installing Splashguard on End and End Case**

An end splashguard ships with each end assembly. End case splashguards ship with the case. Install end splashguards after main splashguards.

1. Check to be sure that all splashguard brackets are level with the floor.
2. Position top of splashguard with the top angled in, behind the lower panel bracket.
3. Raise the splashguard enough to align the tabs on the splashguard brackets with the slots in the bottom edge of the splashguard. Engage the tabs in the slots and drop the splashguard into place.

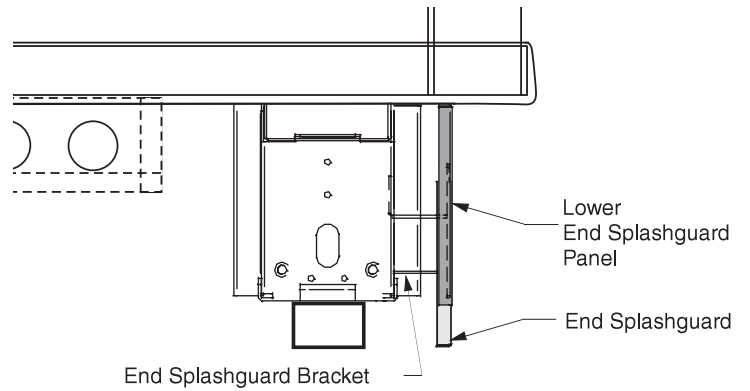
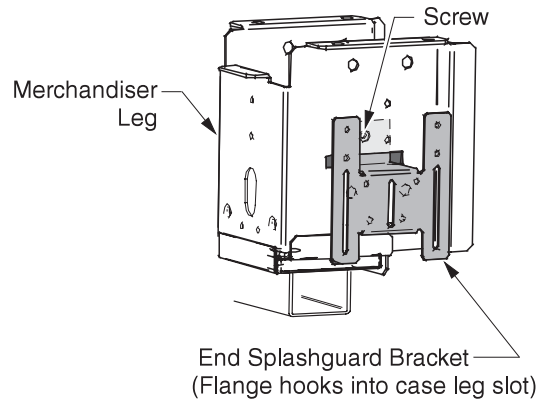

Cove trim may be added in the same way as for the main splashguards.

**End Splashguard Installed**

**End Case Splashguards Installed**

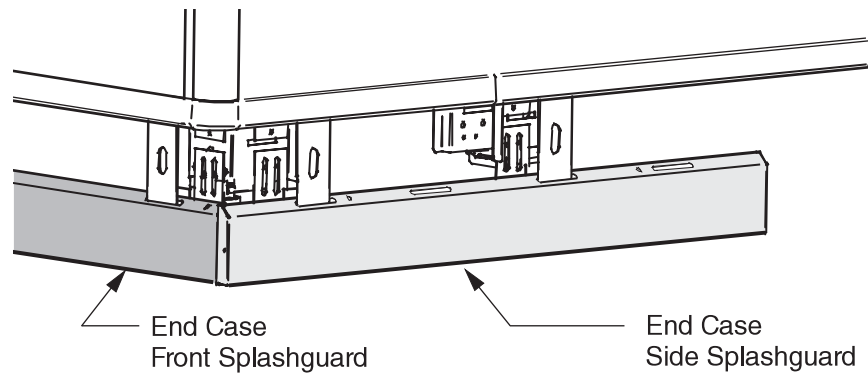

## START UP / OPERATION

### START UP

See the merchandiser's Data Sheet for refrigerant settings and defrost requirements. Bring the merchandiser down to the operating temperatures listed on the data sheet.

### STOCKING

Product should NOT be placed in merchandisers until merchandiser is at proper operating temperature.

Proper rotation of product during stocking is necessary to prevent product loss. Always bring the oldest product to the front and set the newest to the back.

**AIR DISCHARGE AND RETURN FLUES MUST REMAIN OPEN AND FREE OF OBSTRUCTION AT ALL TIMES** to provide proper refrigeration and air curtain performance. Do not allow product, packages, signs, etc. to block these grilles. Do not use non-approved shelving, baskets, display racks, or any accessory that could hamper air curtain performance.

 <h2 style="margin: 0;">CAUTION</h2>
<p><b>At no time should merchandisers be stocked beyond the load limits indicated. Improper stocking can cause poor performance that results in spoiled food.</b></p>

### LOAD LIMITS

Each merchandiser has a load limit decal.



Shelf life of perishables will be short if load limit is violated. Overstocking will adversely affect product temperature and merchandiser efficiency. The load limit is the bottom of the interior panel break. Recommended load limit profiles are shown on the next page.

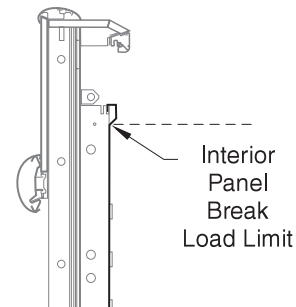

### INSTALLING FDA/NSF REQUIRED THERMOMETER

The following pages provide the same information that ships with the thermometer.

**This requirement does not apply to display refrigerators intended for bulk produce.** (refer to page 1-1).

Please note that the tape cannot be exposed after installation.

LOAD LIMIT PROFILES

F  
FWE

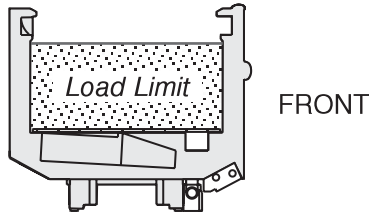

FW

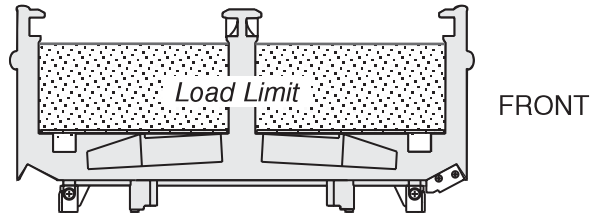

FN  
FI

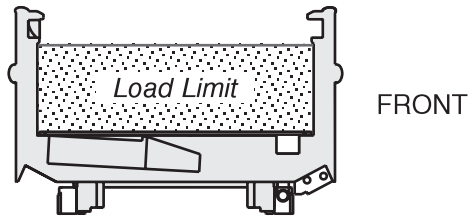

FNG  
FIG

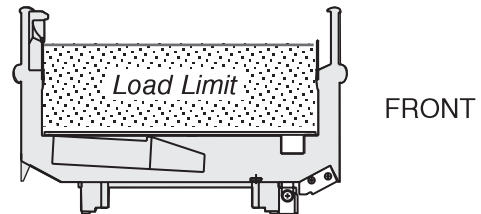

FG  
FWEG

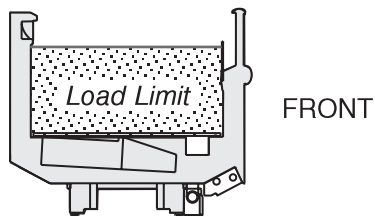

FWG

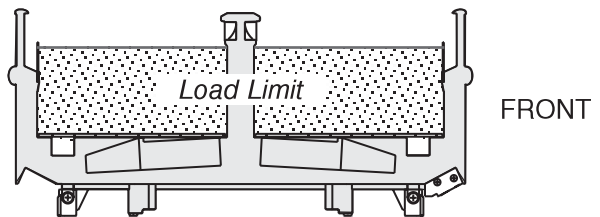

FWEGH

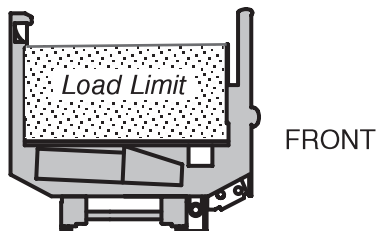

FWGH

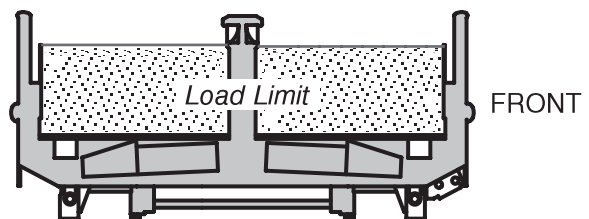

# This is an NSF-7 & US FDA Food Code Required Thermometer

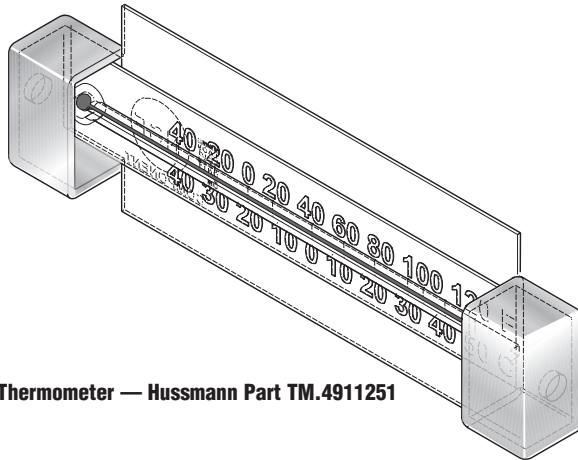

Thermometer — Hussmann Part TM.4911251

Hussmann Corporation • 12999 St. Charles Rock Road • Bridgeton, MO 63044-2483  
U.S. & Canada 1-800-922-1919 • Mexico 1-800-890-2900 • www.hussmann.com  
© 2007 Hussmann Corporation

Suggested Mounting Locations  
in Single Deck Glass Front  
Impact Merchandisers

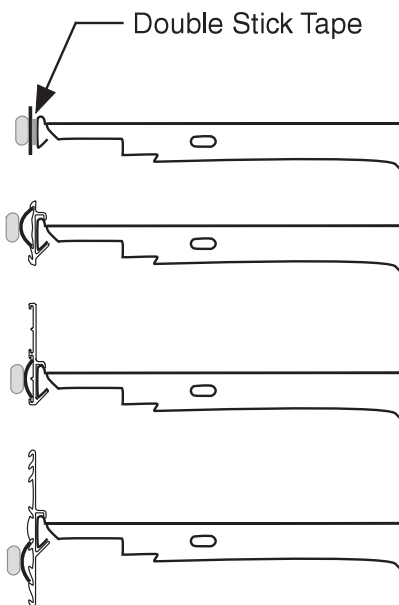
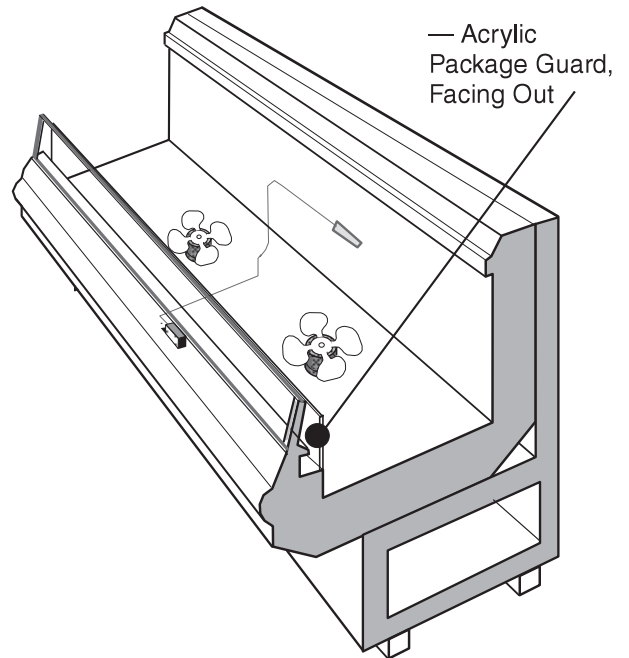

Flexible Plastic  
Fits in Price Tag  
Moldings

Hussmann P/N 0429971\_C

10/2007

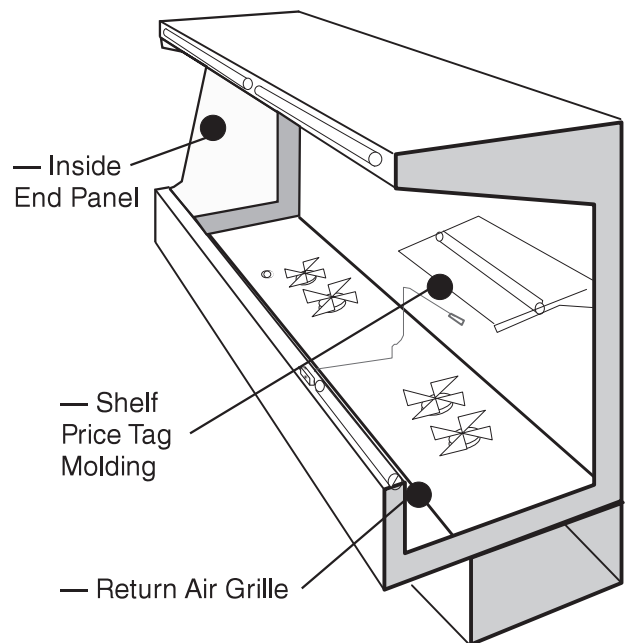

Suggested Mounting Locations  
in Multi-deck Merchandisers

# Important – Please read!

---

This thermometer is provided in response to United States  
Food and Drug Administration (US FDA) Food Code [ <http://www.fda.gov/> ]  
and  
National Sanitation Foundation (NSF / ANSI) Standard 7 [ <http://www.nsf.org/> ]

---

Each installation will be different depending on how the unit is stocked, shopping patterns in the department and ambient conditions of the store. The suggested locations provided herein are possible locations. It is the responsibility of the purchaser / user to determine the location within the food storage area of the unit that best meets the code requirements above.

The thermometer may need to be moved several times to find the warmest location. Mounting options include flexible plastic for price tag molding application, magnet applied to back of flexible plastic for steel end wall, and double stick tape. Tape must not be exposed after installation.

Questions about either code should be addressed to local agencies or other appropriate officials.

---

**Keep with merchandiser**

**or give to store manager.**

**DO NOT DESTROY.**

## MAINTENANCE

### CARE AND CLEANING

Long life and satisfactory performance of any equipment is dependent upon the care it receives. To ensure long life, proper sanitation and minimum maintenance costs, these merchandisers should be thoroughly cleaned, all debris removed and the interiors washed down, weekly.

#### Fan Plenum

To facilitate cleaning, the fan plenum is hinged. After cleaning be sure the plenum is properly lowered into position **OR PRODUCT LOSS WILL RESULT** due to improper refrigeration.

#### Exterior Surfaces

The exterior surfaces should be cleaned with a mild detergent and warm water to protect and maintain their attractive finish. **NEVER USE ABRASIVE CLEANSERS OR SCOURING PADS.**

#### Interior Surfaces

The interior surfaces may be cleaned with most domestic detergents, ammonia based cleaners and sanitizing solutions with no harm to the surface.

#### Do NOT USE:

- Abrasive cleansers and scouring pads, as these will mar the finish.
- A hose on lighted shelves or submerge the shelves in water.
- Solvent, oil or acidic based cleaners on any interior surfaces.
- Ammonia-based cleaners on acrylic parts.
- Coarse paper towels on coated glass.

### **WARNING**

**Prevent injury.**  
**ALWAYS SHUT POWER OFF**  
**during cleaning process.**

#### Do:

- Remove the product and all loose debris to avoid clogging the waste outlet.
- Store product in a refrigerated area such as a freezer. Remove only as much product as can be taken to the freezer in a timely manner.
- First turn off refrigeration, then disconnect electrical power.
- Thoroughly clean all surfaces with soap and hot water.  
**DO NOT USE STEAM OR HIGH WATER PRESSURE HOSES TO WASH THE INTERIOR. THESE WILL DESTROY THE MERCHANDISERS' SEALING CAUSING LEAKS AND POOR PERFORMANCE.**
- Lift hinged fan plenum for cleaning. Hook chain in rear panel to secure plenum during cleaning. **BE SURE TO REPOSITION THE FAN PLENUM AFTER CLEANING MERCHANDISER.**
- Take care to minimize direct contact between fan motors and cleaning or rinse water.
- Rinse with hot water, but do NOT flood. **NEVER INTRODUCE WATER FASTER THAN THE WASTE OUTLET CAN REMOVE IT.**
- Allow merchandisers to dry before resuming operation.
- After cleaning is completed, turn on power and refrigerant to the merchandiser.
- Verify that merchandiser is working properly.



### **CAUTION**

**Product will be degraded and may spoil if allowed to sit in a non-refrigerated area.**



### **CAUTION**

**Do NOT use HOT water on COLD glass surfaces. This can cause the glass to shatter and could result in personal injury. Allow glass fronts, ends, and service doors to warm before applying hot water.**

## CLEANING AIRFLOW LOUVERS

Louvers should be cleaned at least every six months. Dirty louvers adversely affect model performance.

1. Remove screws and louver retainer.
2. Lift the louver, then rotate the bottom out.
3. Clean the louvers with soap and water. Dry thoroughly.
4. When completely dry, re-install louvers and retainer.

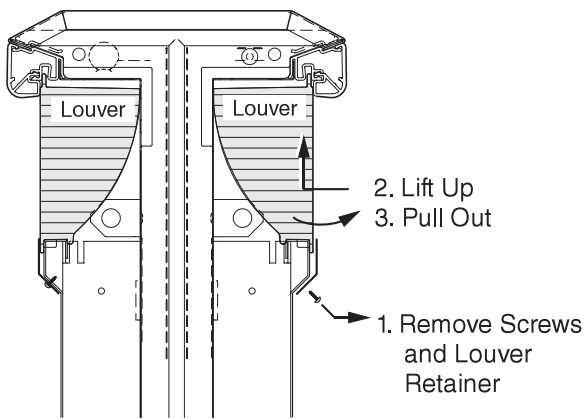

## CLEANING WIRE RACKS, PANS, AND INTERIOR PANELS

With the louver assembly removed, all interior wire racks, supports and drip pans may be lifted out without tools. Refer to illustration on next page.

Begin by lifting out the display racks and front and back display rack supports. Remove display pans, beginning from the left. Pans overlap when properly installed.

Carefully lift up glass package guard to clear clips attached to front panel. It is not necessary to remove clips from panel. Lift out return air grilles. The glass may be cleaned with most domestic detergents, ammonia-based cleaners and sanitizing solutions with no harm to the surface. **NEVER USE ABRASIVE CLEANSERS OR SCOURING PADS.**

Front and rear internal panels rest on interior panel supports. Panels and supports lift out.

Reinstall in reverse order.

## CLEANING STAINLESS STEEL RAILS

Use non-abrasive cleaning materials, and always polish with grain of the steel. Use warm water or add a mild detergent to the water and apply with a cloth. Always wipe rails dry after wetting.

Use alkaline chlorinated or non-chlorine containing cleaners such as window cleaners and mild detergents. Do not use cleaners containing salts as this may cause pitting and rusting of the stainless steel finish. Do not use bleach.

Clean frequently to avoid build-up of hard, stubborn stains. A stainless steel cleaning solution may be used periodically to minimize scratching and remove stains.

Rinse and wipe dry immediately after cleaning. Never use hydrochloric acid (muriatic acid) on stainless steel.

**FWG Shown — Other  
Low Temperature  
Excel Model Parts  
are Similar**

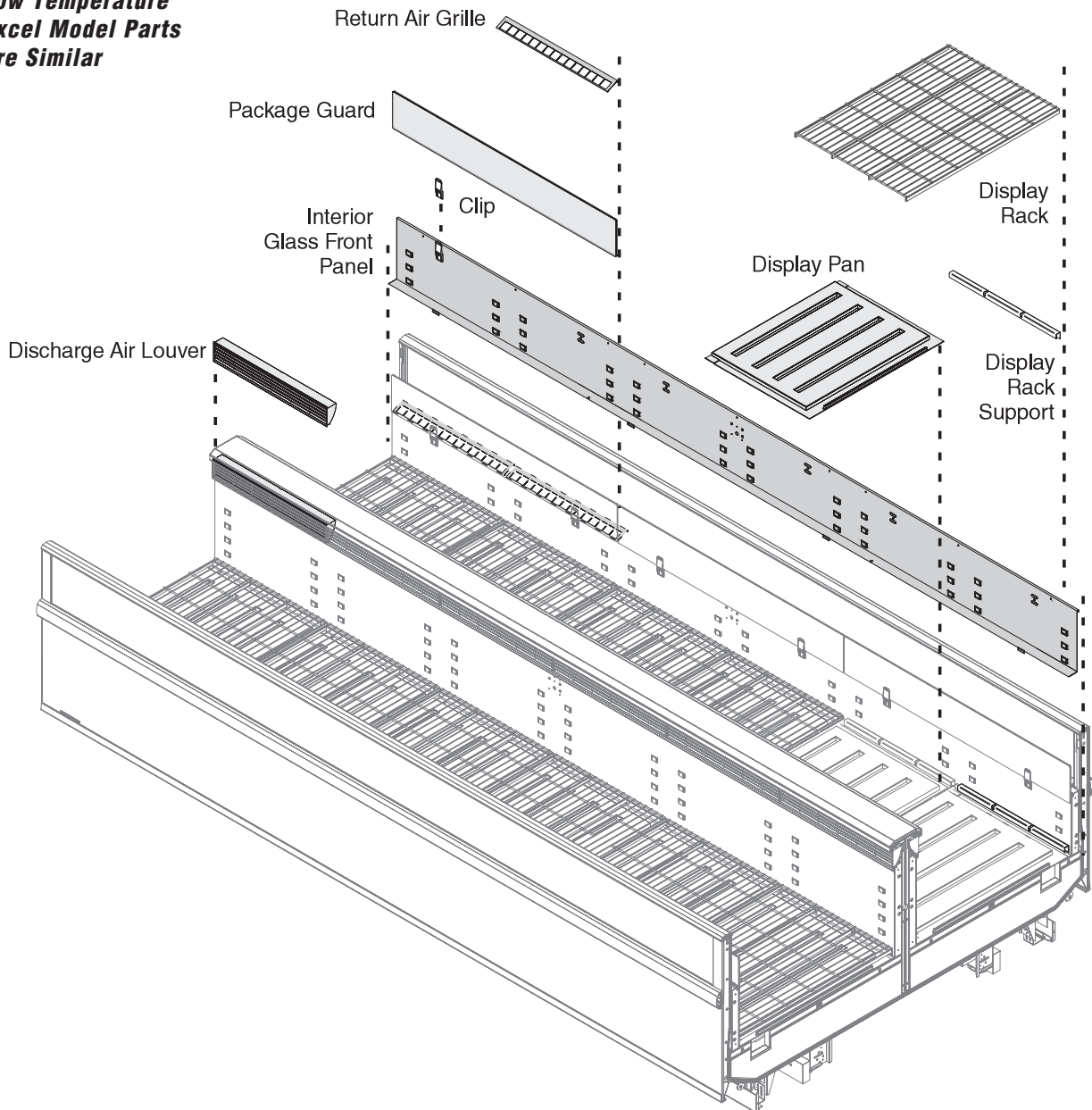

## CLEANING COILS

**NEVER USE SHARP OBJECTS AROUND COILS.** Use a soft brush or vacuum brush to clean debris from coils. **Do not puncture coils!** Do not bend fins. Contact an authorized service technician if a coil is punctured, cracked, or otherwise damaged.

**ICE** in or on the coil indicates the refrigeration and defrost cycle is not operating properly. Contact an authorized service technician to determine the cause of icing, and to make adjustments as necessary. To maintain product integrity, move all product to a cooler until the unit has returned to normal operating temperatures.

**REMOVING REAR FLUE GLASS FOR CLEANING (FIG & FNG)**

1. Remove louvers, then remove the discharge deflector brackets. The flue glass (with retainer) may then be lifted out.
2. Remove interior panels to facilitate thorough cleaning.
3. Reinstall in reverse order.

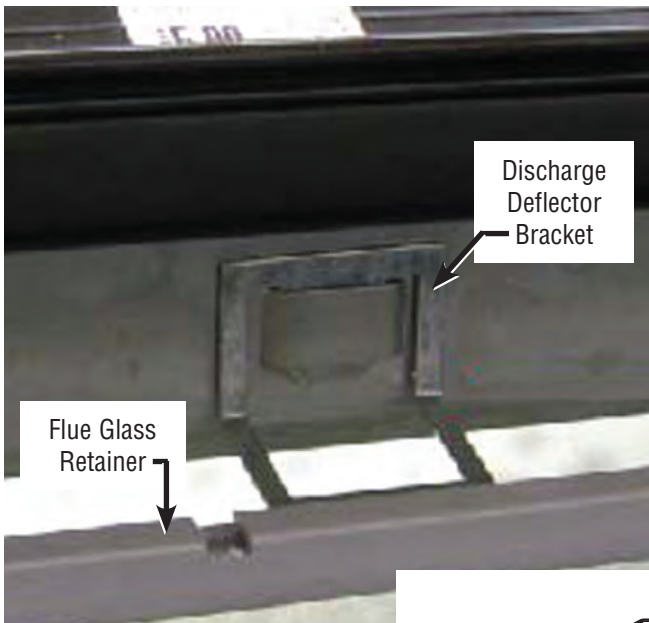
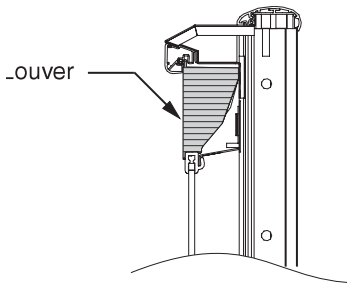

**REMOVING SCRATCHES FROM BUMPER**

Most scratches and dings can be removed using the following procedure.

1. Use steel wool to smooth out the surface area of the bumper or top rail.
2. Clean area.
3. Apply vinyl or car wax and polish surface for a smooth glossy finish.

**CLEANING UNDER MERCHANDISERS**

Remove splashguards not sealed to floor. Use a vacuum with a long wand attachment to remove accumulated dust and debris from under the merchandiser.

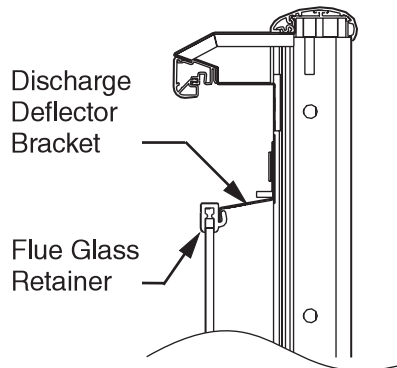
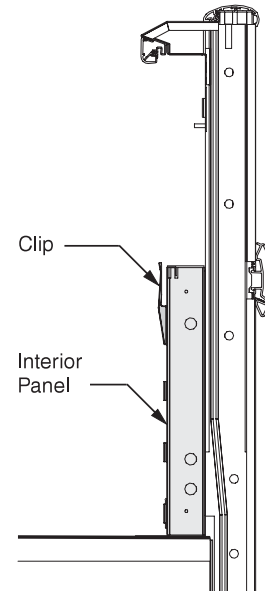

## GENERAL

Refer to the case data sheet for each model to identify the general location of components.



# WARNING

**— LOCK OUT / TAG OUT —**

***To avoid serious injury or death from electrical shock, always disconnect the electrical power at the main disconnect when servicing or replacing any electrical component. This includes, but is not limited to, such items as doors, lights, fans, heaters, and thermostats.***

## REPLACING FAN MOTORS AND BLADES

See cross section for location of evaporator fans. Should it ever be necessary to service or replace the fan motors or blades be certain that the fan blades are re-installed correctly.

For access to evaporator fans:

1. Turn off power.
2. Remove wire racks and display pans from the compartment being serviced.
3. **Disconnect fan from wiring harness.**
4. Remove fan blade.
5. Remove screws holding fan motor/bracket assembly to plenum and remove assembly.
6. Replace fan motor/bracket assembly and reinstall screws.
7. Reinstall fan blade.
8. Reconnect fan to wiring harness.
9. Turn on power.
10. Verify that motor is working and blade is turning in the correct direction.
11. Replace display pans and wire racks. Bring merchandiser to operating temperature before restocking.

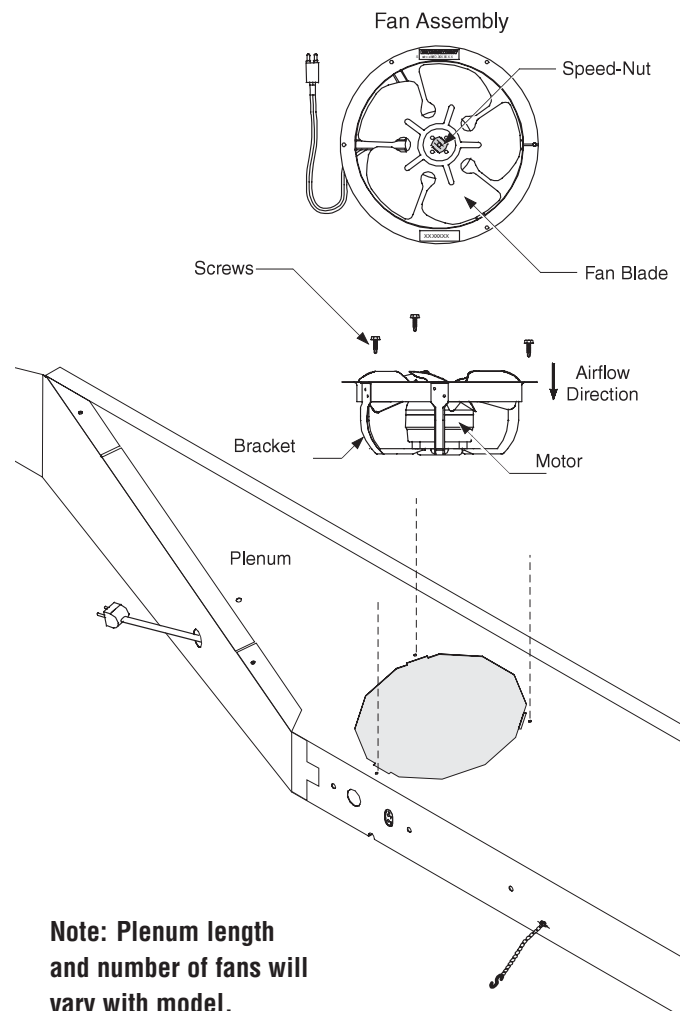

**Note: Plenum length and number of fans will vary with model.**

## REPLACING ELECTRIC DEFROST HEATER

These heaters are installed at the front of the coils. They may be accessed by lifting the fan plenums. To replace:

1. Turn off power to merchandiser.
2. Remove wire racks and display pans from the compartment being serviced.
3. Hinge up and fasten the fan plenum to the interior back panel with chain and hook provided.
4. Unplug the heater from the heater harness.
5. Remove the heater from the face of the coil by rotating the support tab far enough to free the heater element.
6. Position the new heater and rotate the support tab back to the original position.
7. Reconnect heater to wiring harness.
8. Lower the fan plenum to operating position.
9. Reconnect power.
10. Verify heater is working properly.
11. Replace display pans and wire racks. Bring merchandiser to operating temperature before restocking.

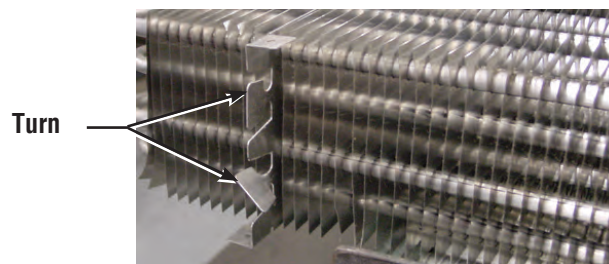
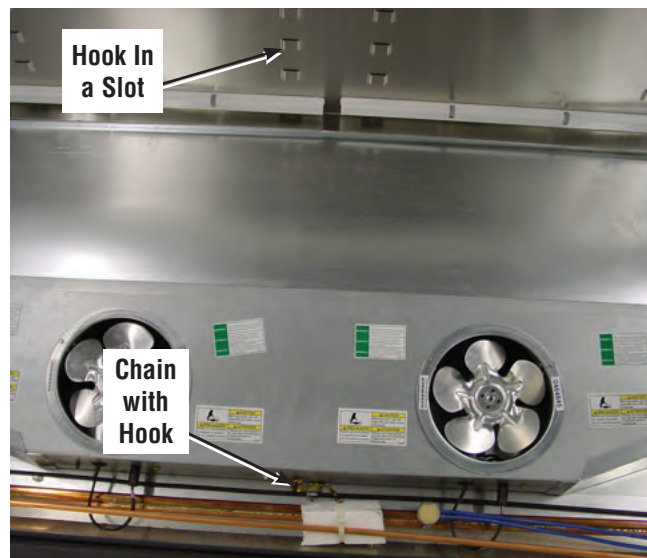
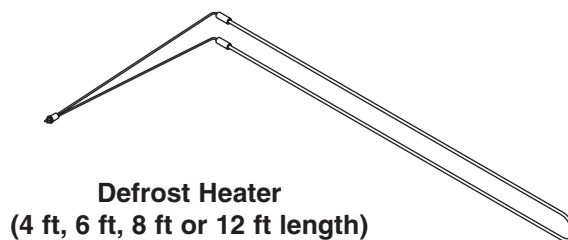

## **WARNING**

— **LOCK OUT / TAG OUT** —

***To avoid serious injury or death from electrical shock, always disconnect the electrical power at the main disconnect when servicing or replacing any electrical component. This includes, but is not limited to, such items as doors, lights, fans, heaters, and thermostats.***

**REPLACING HAND RAIL HEATER  
(SOLID FRONTS)**

To replace the heater:

1. Turn OFF the power to the merchandiser.
2. Remove return grilles, package guard and interior panel as needed from the compartment being serviced.
3. Remove screw and corner cap.
4. Remove screws, grounding wire harness and corner cap bracket.

5. Remove hand rails, hand rail retainers and heater from hand rail retainers.
6. Remove wireway cover.

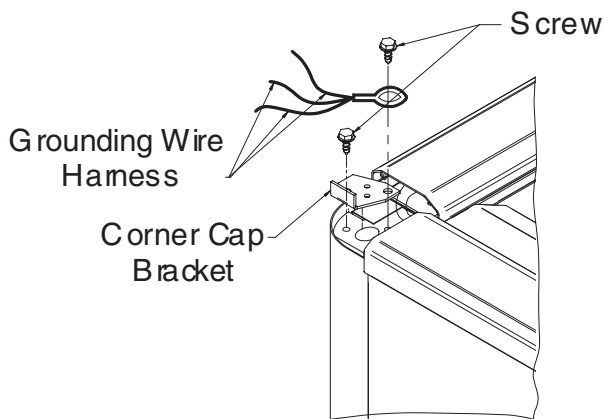
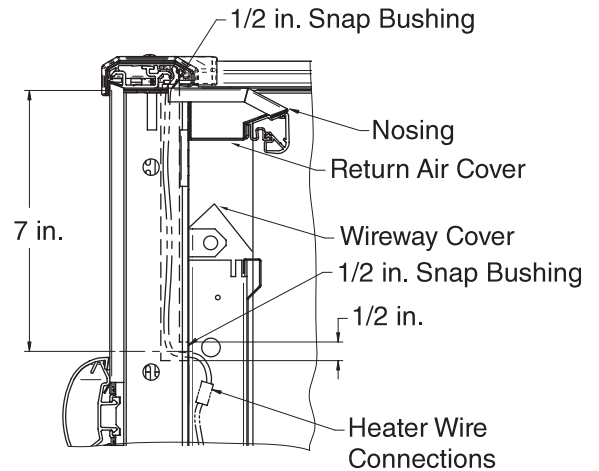
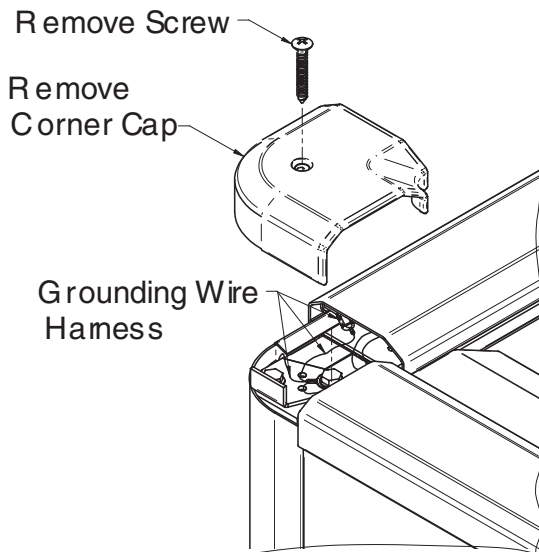

**! WARNING**

**— LOCK OUT / TAG OUT —**

*To avoid serious injury or death from electrical shock, always disconnect the electrical power at the main disconnect when servicing or replacing any electrical component. This includes, but is not limited to, such items as doors, lights, fans, heaters, and thermostats.*

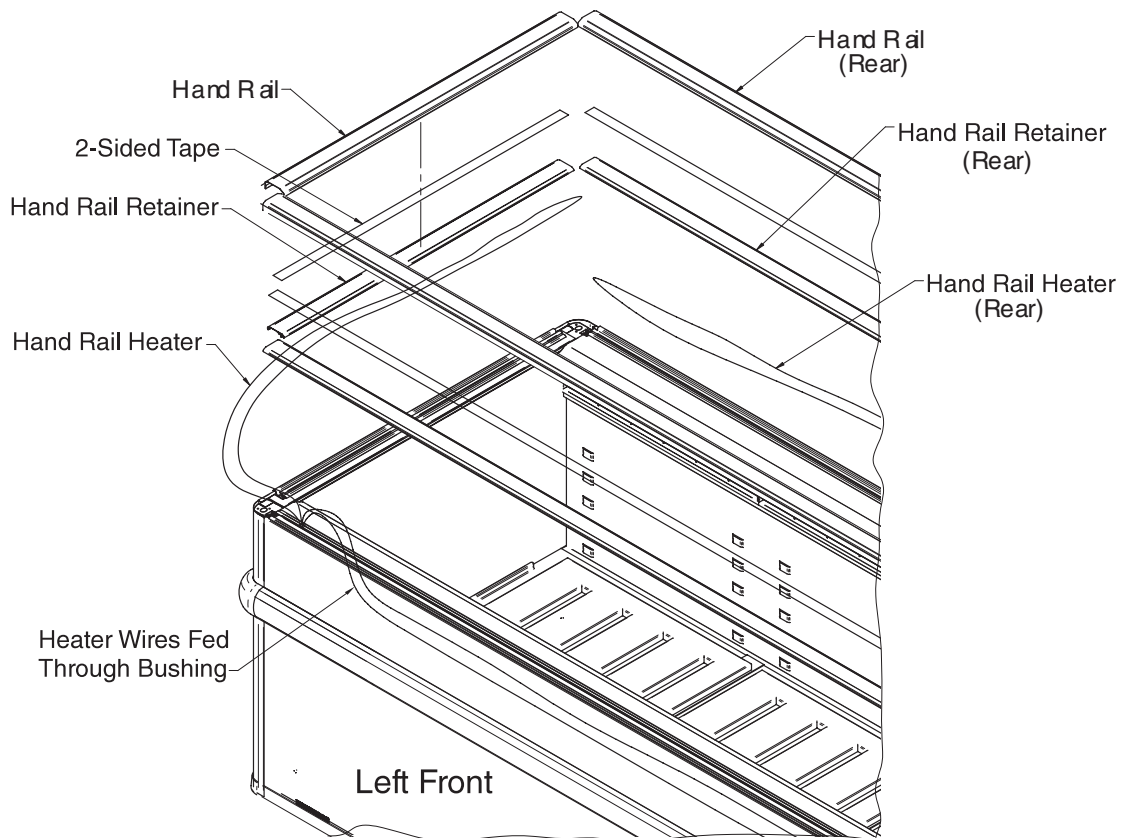

7. Disconnect, and remove hand rail heater from wireway.
8. Replace heater connections and re-route new heater onto hand rail retainers.
9. Clean rail surfaces thoroughly, then install new hand rail heater.
10. Reinstall parts in reverse order. Any damaged parts must be replaced.

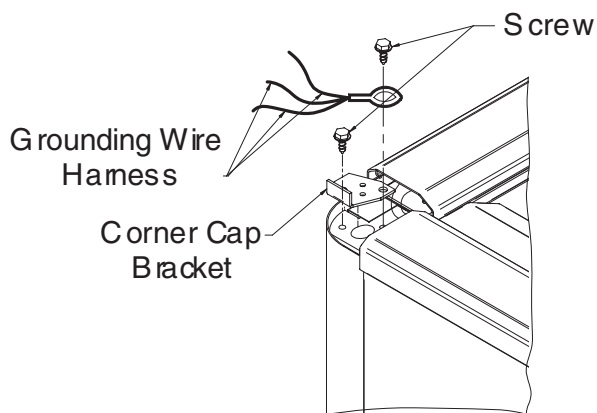

Metal top rail must be properly grounded.

## REPLACING HAND RAIL HEATER (GLASS FRONTS)

To replace the heater:

1. Turn OFF the power to the merchandiser.
2. Remove wire racks, display pans, return grilles, package guard and interior panel from the compartment being serviced.

Hand rail heater connections are located in left front corner of merchandiser (near serial plate). **FWEG** heater connections are at right rear corner of merchandiser.

3. Remove screw and corner cap.

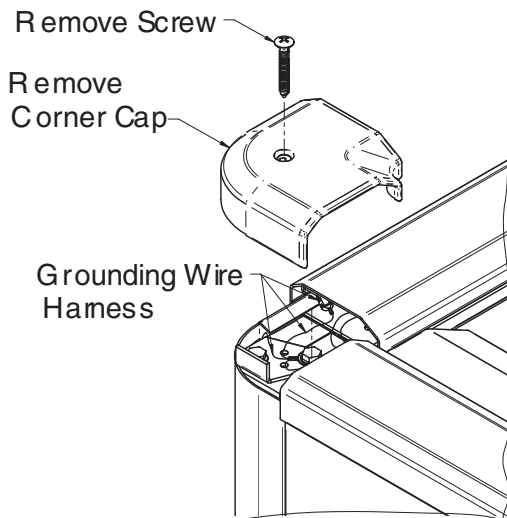

4. Remove screws, grounding wire harness and remove corner cap bracket.

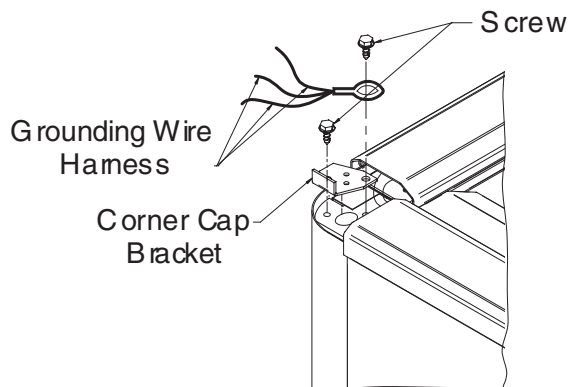

5. Remove hand rails, hand rail retainers and heater from hand rail retainers.
6. Remove interior joint trim and wireway cover.

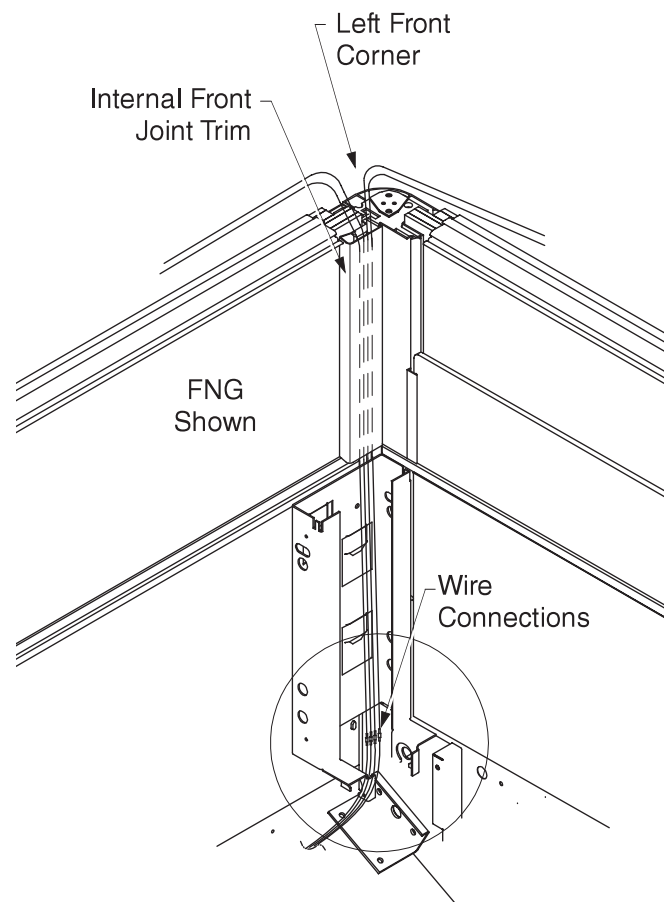

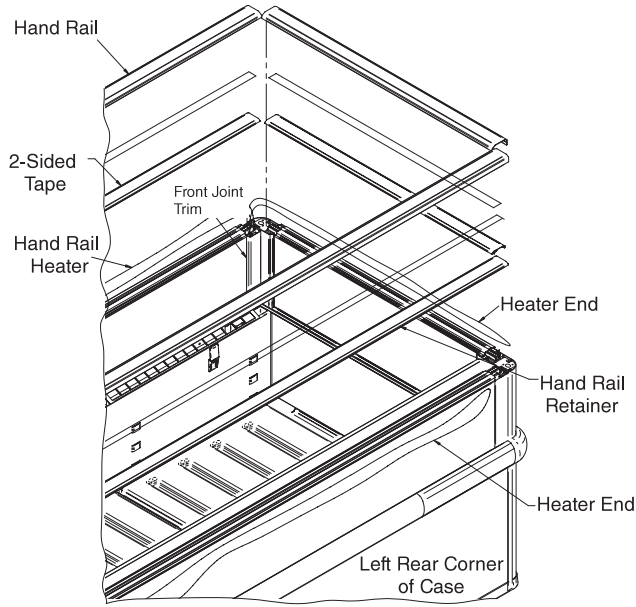

Hand Rail Heater Connections are Located in Left Front Corner of Merchandiser (Near Serial Plate)

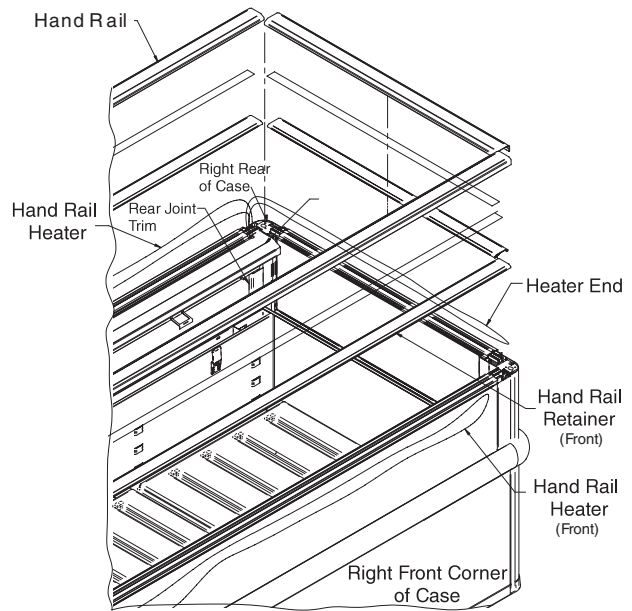

**FWEG** Heater Connections are at Right Rear Corner of Merchandiser

- 7. Disconnect and remove hand rail heater from wireway.
- 8. Replace heater connections and re-route new heater through internal front joint trim and onto hand rail retainers as shown.

- 9. Clean rail surfaces thoroughly, then install new hand rail heater.
- 10. Reinstall parts in reverse order. Any damaged parts must be replaced.

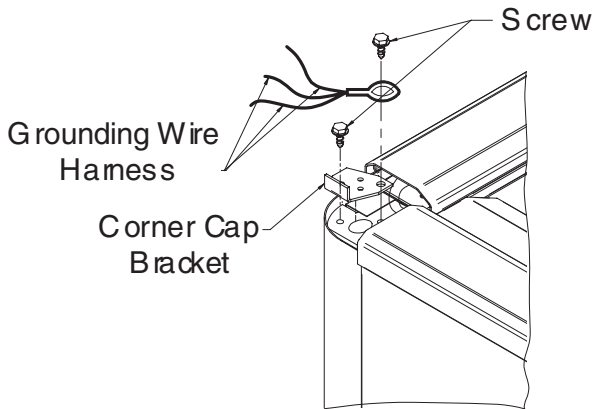

Metal top rail must be properly grounded.

**! WARNING**

— LOCK OUT / TAG OUT —

*To avoid serious injury or death from electrical shock, always disconnect the electrical power at the main disconnect when servicing or replacing any electrical component. This includes, but is not limited to, such items as doors, lights, fans, heaters, and thermostats.*

## REPLACING RETURN AIR HEATER

To replace the heater:

1. Turn OFF the power to the merchandiser.
2. Remove return grilles, package guard and interior panel from the compartment being serviced.
3. Remove screw and wireway cover.
4. Unplug existing return air heater. The return air heater plug is routed on RH side from front of merchandiser (end opposite the main serial plate).
5. Remove screws and retainer.
6. Remove the foil tape and heater from the retainer.
7. Clean thoroughly. Remove all adhesive and residue. Wipe surface with alcohol to ensure new heater tape will adhere properly.
8. Install new heater and tape in retainer as shown.
9. Reinstall retainer, routing plug to jumper harness; plug in.
10. Reinstall wireway cover, interior panel, package guard, return air grilles, display pans and wire racks.
11. Turn on power to merchandiser and check for proper operation.

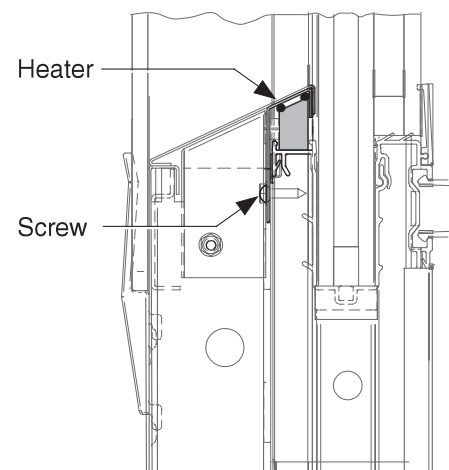
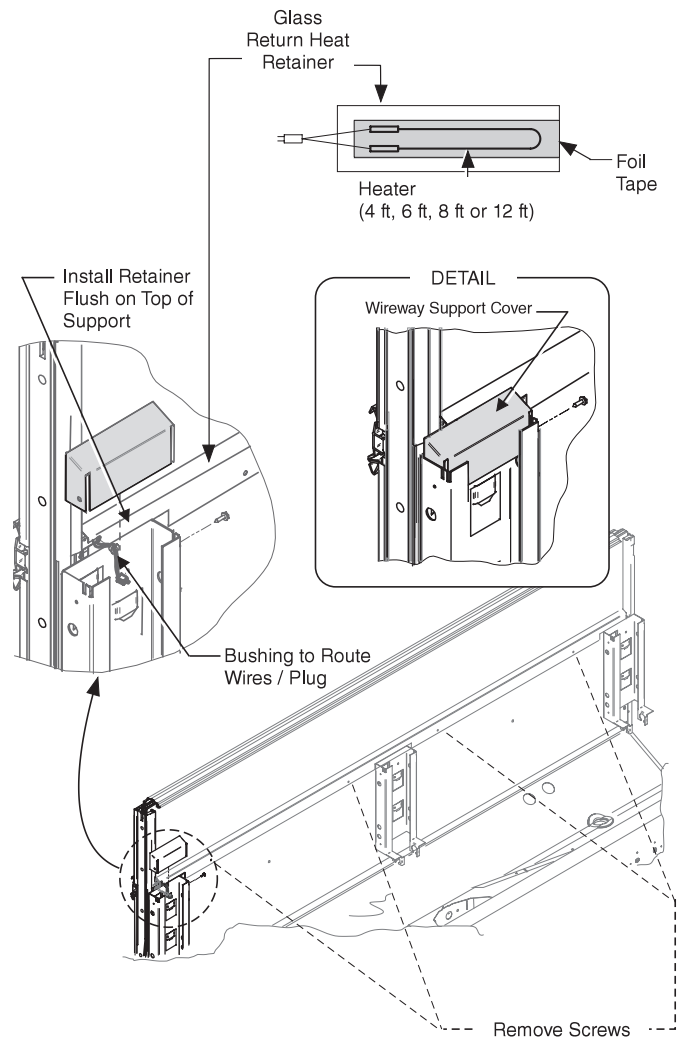

## **! WARNING**

— LOCK OUT / TAG OUT —

*To avoid serious injury or death from electrical shock, always disconnect the electrical power at the main disconnect when servicing or replacing any electrical component. This includes, but is not limited to, such items as doors, lights, fans, heaters, and thermostats.*

## REPLACING PRODUCT SIDE HEATER (FWGH & FWEHG ONLY)

To replace the heater:

1. Turn OFF the power to the merchandiser.
2. Remove return grilles, package guard and interior panel from the compartment being serviced.
3. Remove the pop rivets. Rivets will be drilled out. Unplug existing product side heater. Heater is routed on RH side from front of merchandiser (end opposite the main serial plate).
4. Clean thoroughly. Remove all adhesive and residue. Wipe surface with alcohol to ensure new heater tape will adhere properly.
5. Install new heater and tape in retainer as shown.
6. Reinstall retainer, routing plug to jumper harness; plug in.
7. Reinstall wireway cover, interior panel, package guard, return air grilles, display pans and wire racks.
8. Turn on power to merchandiser and check for proper operation.

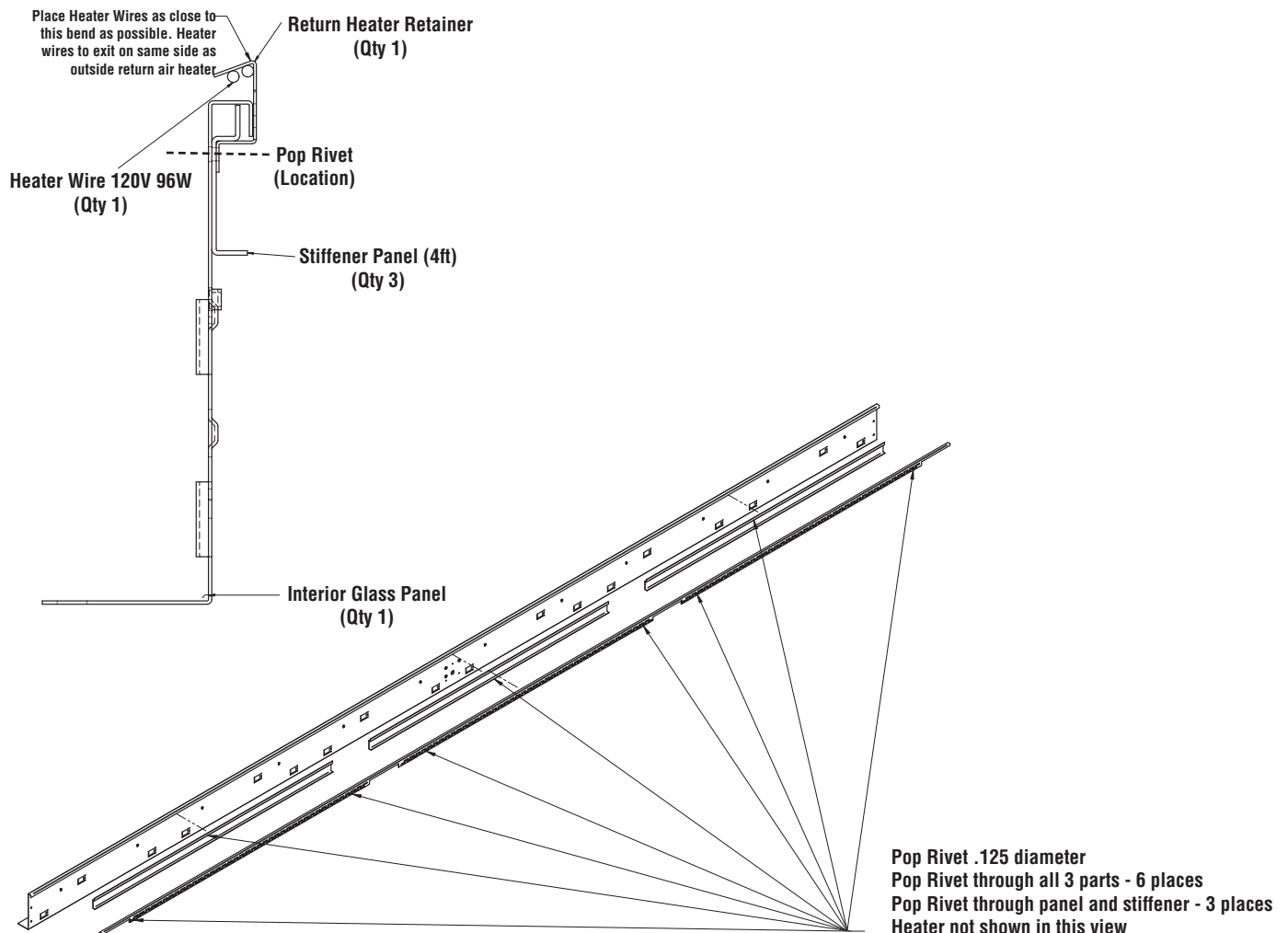

## REPLACING NOSING ANTI-SWEAT HEATER

To replace the heater:

1. Turn OFF the power to the merchandiser.
2. Remove a louver from one end. It doesn't matter which end.
3. Remove exterior nosing extrusion by placing fingers at the back end of the extrusion and pulling forward until it separates from the interior nosing extrusion.

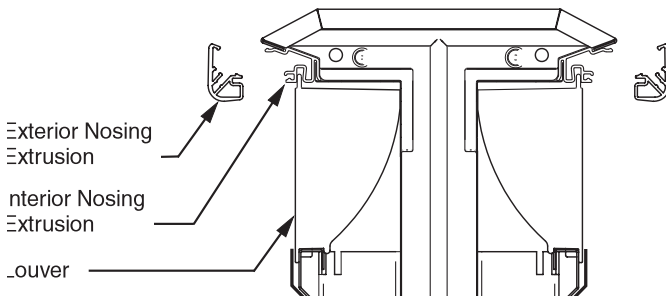

4. Unplug and remove existing anti-sweat heater. The anti-sweat heater plug is routed on RH side from front of merchandiser (end opposite the main serial plate).
5. Install new anti-sweat heater as shown and route plug to jumper harness; plug in.

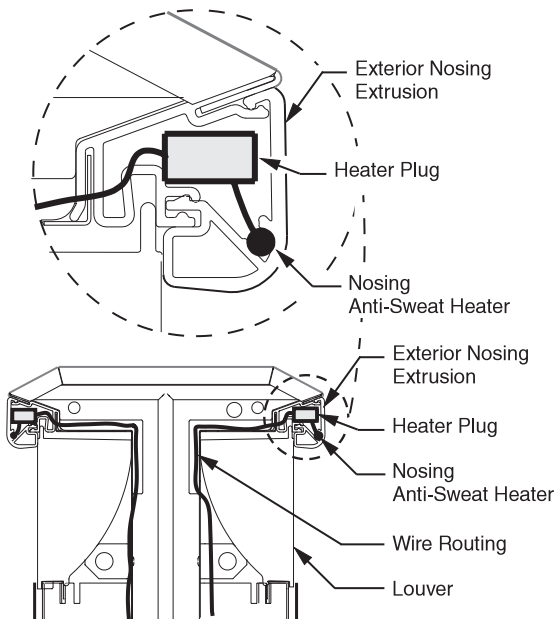

6. Do the following to reattach exterior nosing extrusion to interior nosing extrusion: There are two joining locations "A" and "B" that must be fastened to the interior nosing extrusion. "A" can be positioned in place by hand. Use a rubber mallet to snap "B" into place at interior extrusion. A light to medium tap is all that is required.

NOTE: It is easier to reinstall plastic extrusion if wide PTM is removed.

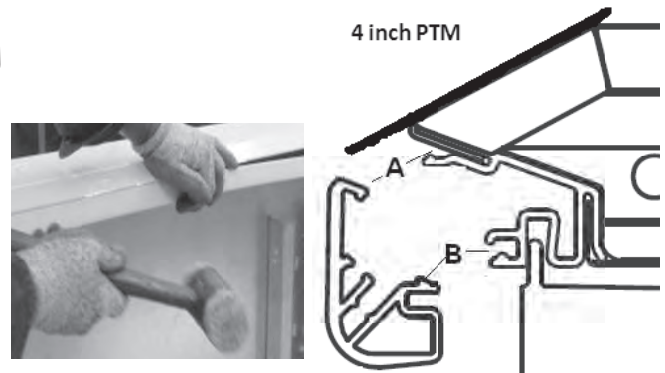

7. Replace discharge air louver, retainer and fasteners.

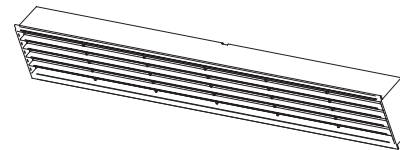

8. Turn on power to merchandiser, and check for proper operation.

**⚠ WARNING**

**— LOCK OUT / TAG OUT —**

*To avoid serious injury or death from electrical shock, always disconnect the electrical power at the main disconnect when servicing or replacing any electrical component. This includes, but is not limited to, such items as doors, lights, fans, heaters, and thermostats.*

## CENTER FLUE SUPERSTRUCTURE ANTI-SWEAT HEATER REPLACEMENT MODEL: FW-S

To replace the heater:

1. Turn off power to the merchandiser.
2. Remove the shelves from the section of the superstructure that requires heater replacement.
3. Unscrew, and remove the night curtain covers.
4. Remove the night curtains from the spring clip using a flat head screwdriver.
5. Unscrew and raise the center flue heater cover, and remove the center flue insulation.
6. Unplug the heater from the anti-sweat heater supply harness, and remove it.
7. Apply the new heater to the center flue using the adhesive backing.
8. Connect the heater leads to the anti-sweat heater supply harness, and reverse the steps to install the insulation, heater cover, and night curtains.

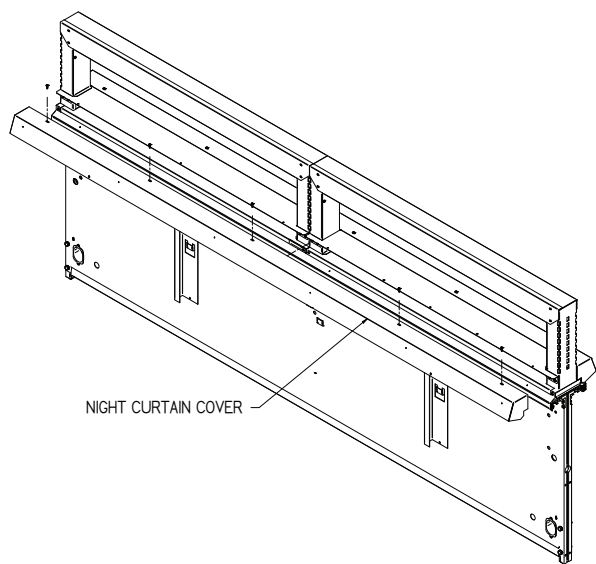

4. Remove the night curtains from the spring clip using a flat head screwdriver.
5. Unscrew and raise the center flue heater cover, and remove the center flue insulation.

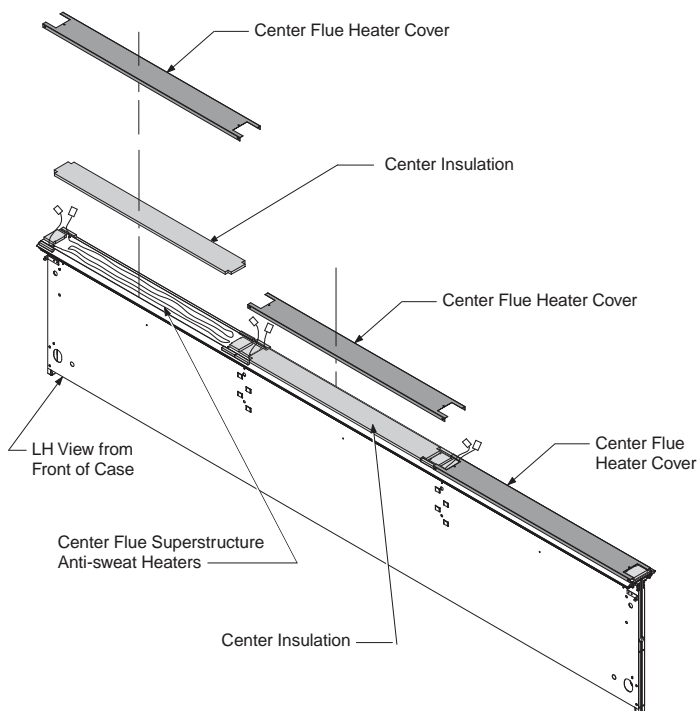
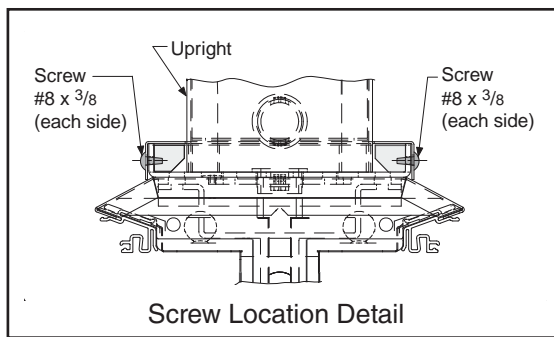

### Insulation and Heater Covers (Step 5)

For clarity, the superstructure assembly is not shown.

### REPLACING DRIP PAN HEATER

1. Turn off power to the merchandiser.
2. Remove wire racks and display pans from the compartment being serviced.
3. Unplug the heater from the heater harness.
4. Remove heater lead wire from interior panel supports.
5. Remove all screws and clips, then remove the heater.
6. Position the new heater. Apply new acrylic sealer to the underside of clips. Carefully *reinstall clips in their original position*.
7. Route heater lead wire through the interior panel supports.
8. Reconnect harness.
9. Turn on power to merchandiser and check for proper operation.
10. Reinstall display pans and wire racks.

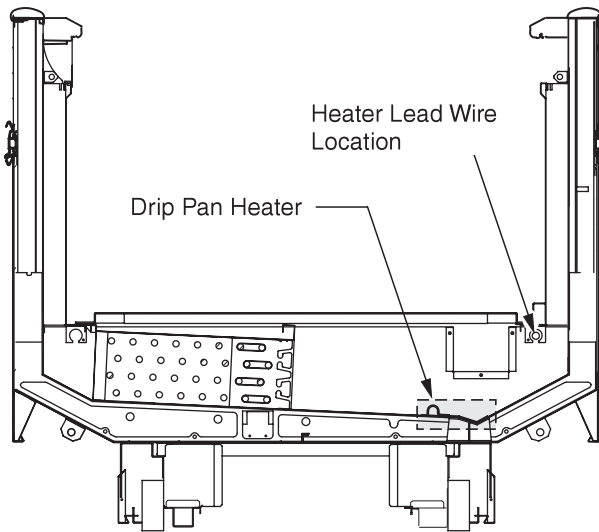

Drip Pan Heater Assembly

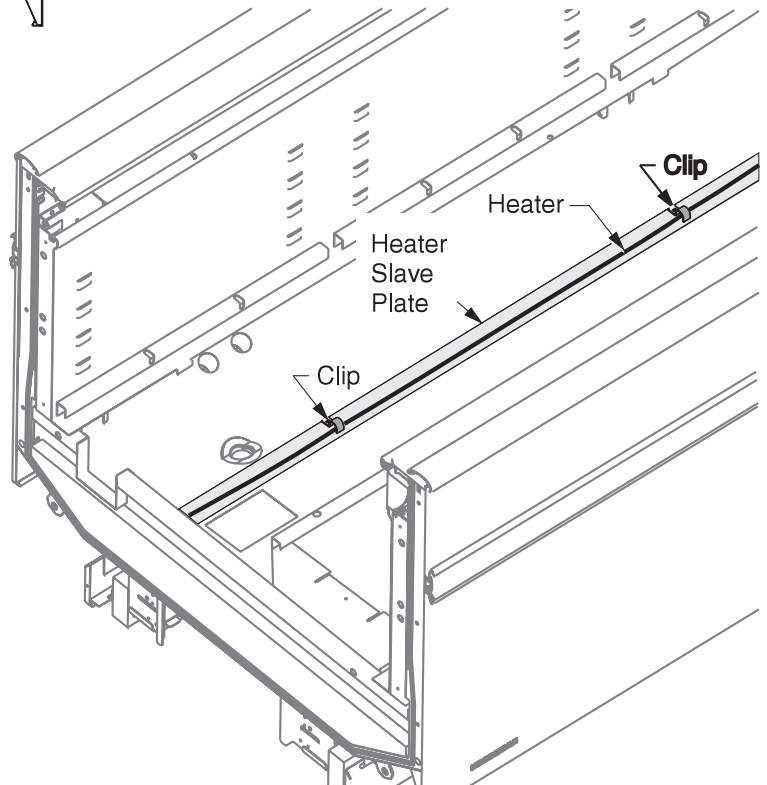
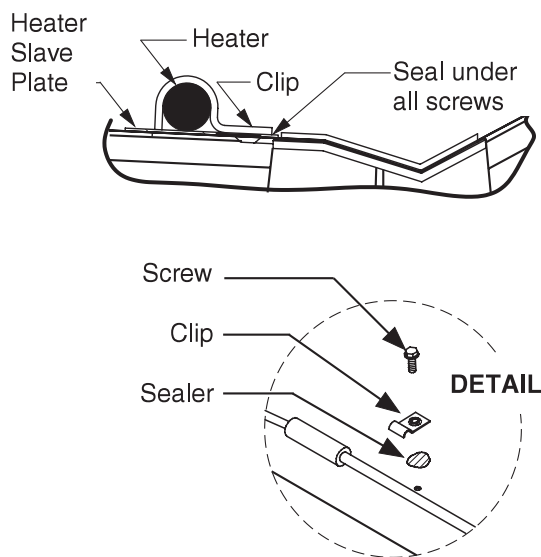
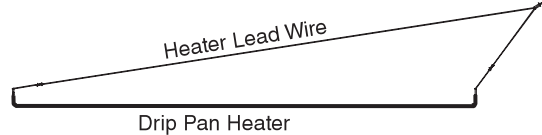

## REPLACING DISCHARGE THERMOPANE GLASS ASSEMBLY (FNG and FIG)

Requires TWO (2) people.

*Always use gloves when handling glass.*

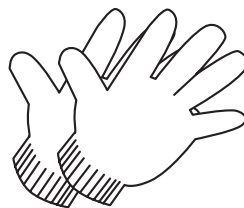

Always Use Gloves  
When Handling Glass!!

1. Turn off power to merchandiser.
2. Remove louvers, package guards, discharge rear deflector module and hand rail. (Hand rail removal is shown on Page 6-9.)
3. Disconnect glass pane heater lead wires from the wiring junctions.
4. With one person standing at each end of glass, lift the thermopane glass assembly straight up to remove it from its retainer channel and the end posts.
5. To install glass, have one person hold each end of the thermopane glass assembly and carefully lower it into the retainer channel and end posts.

NOTE: It may be necessary to use a wide, thin tool (such as a putty knife) to keep trim from obstructing glass positioning.

6. Reconnect glass pane heater lead wires.
7. Reinstall hand rail, discharge rear deflector, package guards and louvers.
8. Turn on power. Verify that heater is working properly.

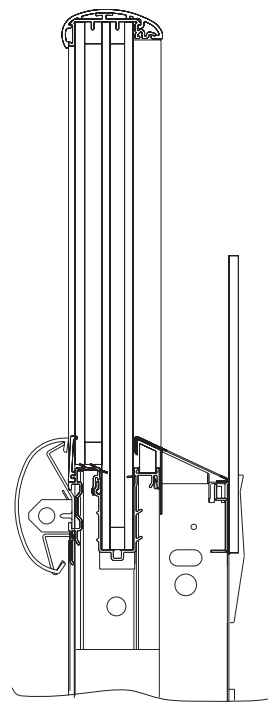

# WARNING

— LOCK OUT / TAG OUT —

***To avoid serious injury or death from electrical shock, always disconnect the electrical power at the main disconnect when servicing or replacing any electrical component. This includes, but is not limited to, such items as doors, lights, fans, heaters, and thermostats.***

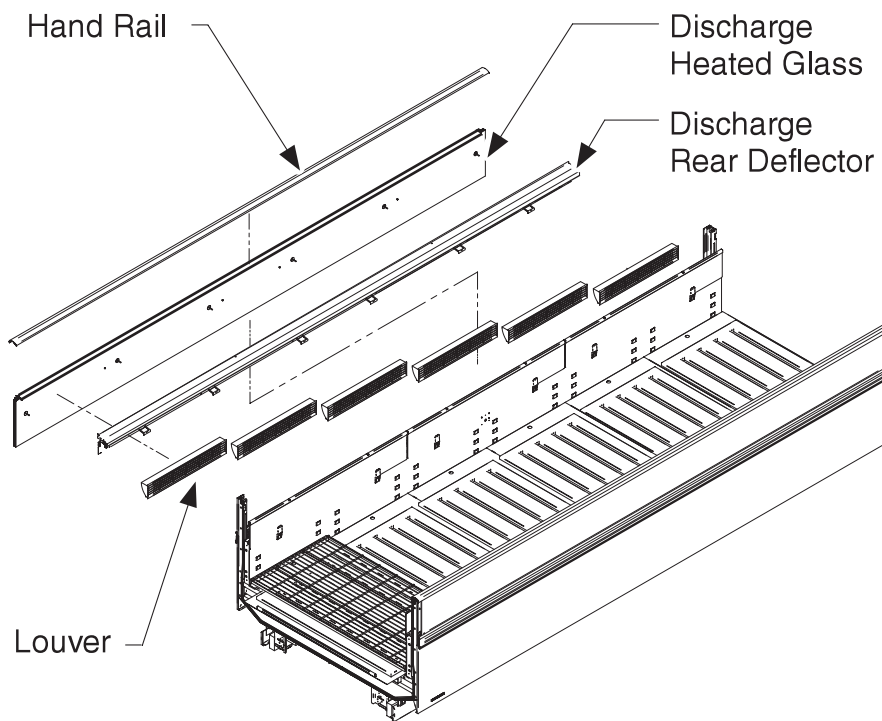
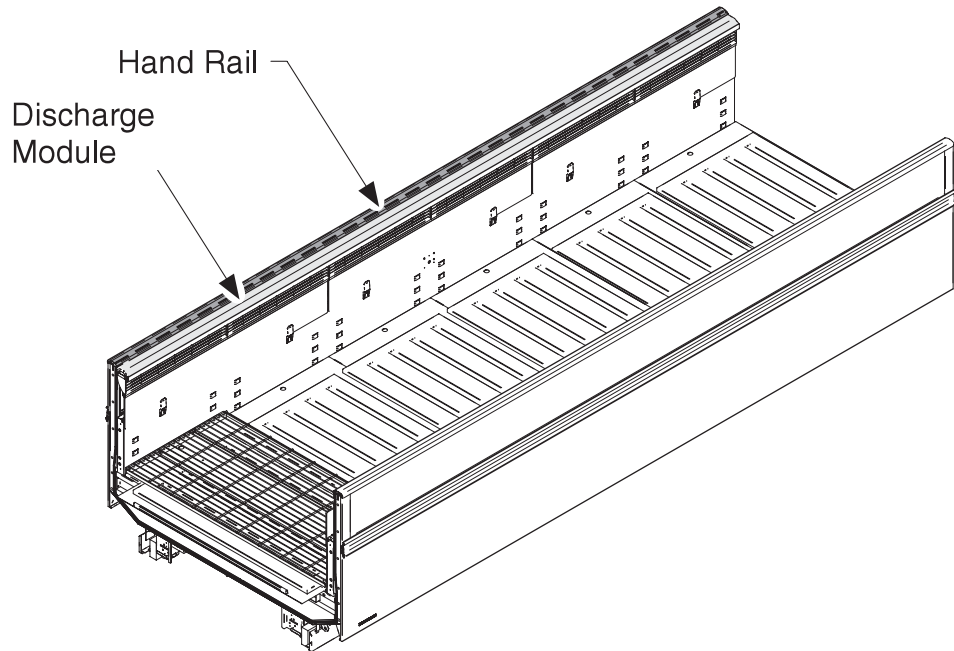

## REPLACING RETURN THERMOPANE GLASS ASSEMBLY

Requires TWO (2) people.

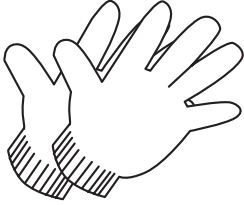

*Always use gloves when handling glass.*

1. Turn off power to merchandiser.
2. Remove hand rail.
3. Disconnect glass pane heater lead wires from the wiring junctions.
4. With one person standing at each end of the glass, lift the thermopane glass assembly straight up to remove it from its retainer channel and end posts.
5. To install glass, have one person hold each end of the thermopane glass assembly and carefully lower it into the retainer channel and end-posts.

Note: It may be necessary to use a wide thin tool (such as a putty knife) to keep trim from obstructing glass positioning. Refer to illustration on page 6-6.

6. Reconnect glass pane heater lead wires.
7. Replace hand rail.
8. Turn on power. Verify the heater is working properly.

## **WARNING**

— **LOCK OUT / TAG OUT** —

**To avoid serious injury or death from electrical shock, always disconnect the electrical power at the main disconnect when servicing or replacing any electrical component. This includes, but is not limited to, such items as doors, lights, fans, heaters, and thermostats.**

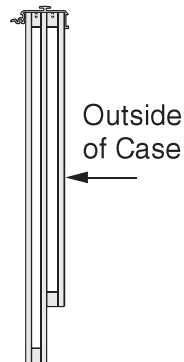

Glass Assembly

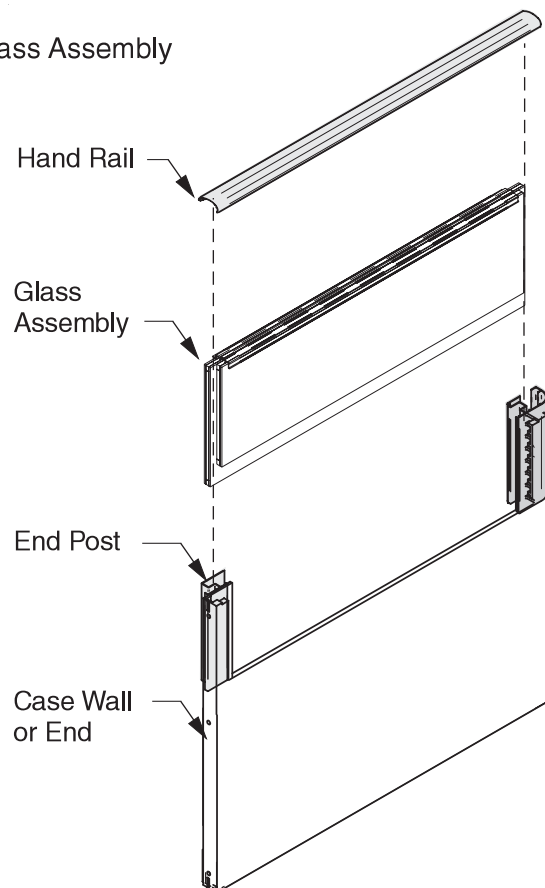

### REPLACING HAND RAIL

Beginning at one end, remove the hand rail by pressing down, 1, and back, 2, to release the back corner from its retainer (refer to the following illustration). Work along the back (inside) until the full length is free. Rotate the hand rail out to release the front edge.

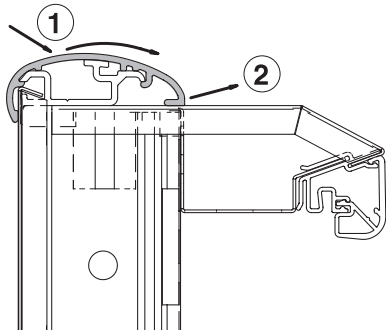

To reinstall, catch the front edge of the hand rail retainer with the inside front of the hand rail as shown in the following illustration, 1. Rotate the hand rail in toward the case and press down, 2, until back of hand rail snaps over back of retainer.

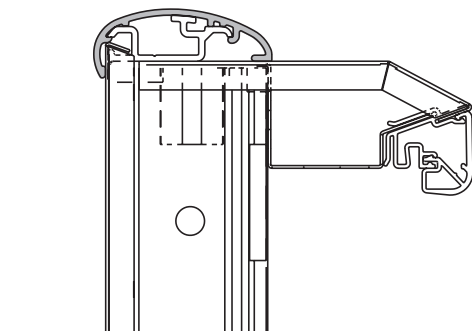
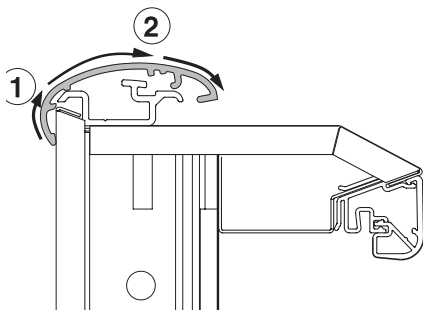

Hand Rail Snapped onto Retainer

### REPLACING PANEL EDGE GUARD

Beginning at one end of the edge guard, insert a thin wide **plastic** tool (such as a putty knife) to separate the guard from the panel until a finger can be inserted to rotate the guard off the panel. Work the length of the panel.

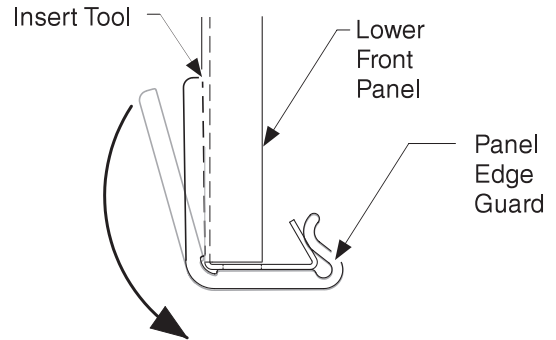

To reinstall, hook the curved leg of the edge guard behind the flange on the lower front panel. Rotate the edge guard forward to snap onto the lower front panel. Refer to the following illustrations.

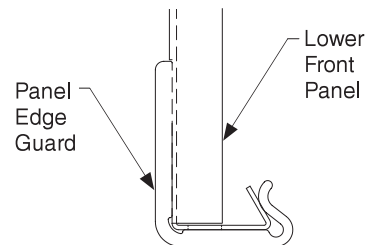
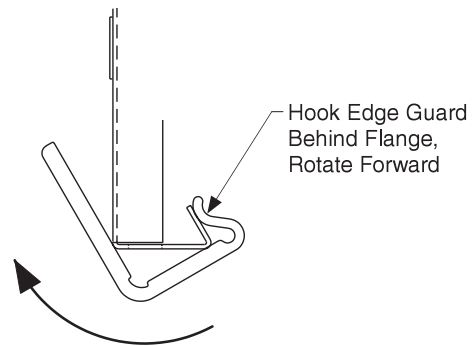

Edge Guard Snapped onto Lower Front Panel

### SUPERSTRUCTURE LED POWER SUPPLY REPLACEMENT (FW-S)

1. Turn off power to the merchandiser.
2. Remove the raceway cover from the impacted section.
3. Unplug the power supply requiring replacement from the supply harness and LED shelf light harness
4. Install the new power supply, and connect to harnesses.
5. Replace cover.

### NIGHT CURTAIN ADJUSTMENT (FW-S)

The night curtain return spring can be adjusted by using a flat head screwdriver to adjust the screw located on the end of the night curtain assembly.

Turn the screw clockwise to increase tension, and counterclockwise to decrease tension.

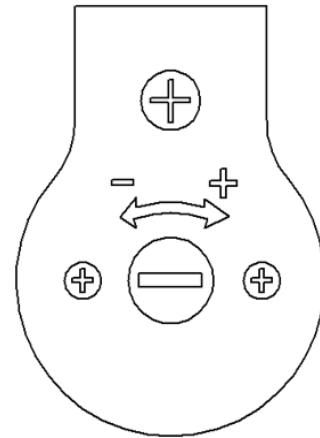

Night Curtain  
(End Shown)

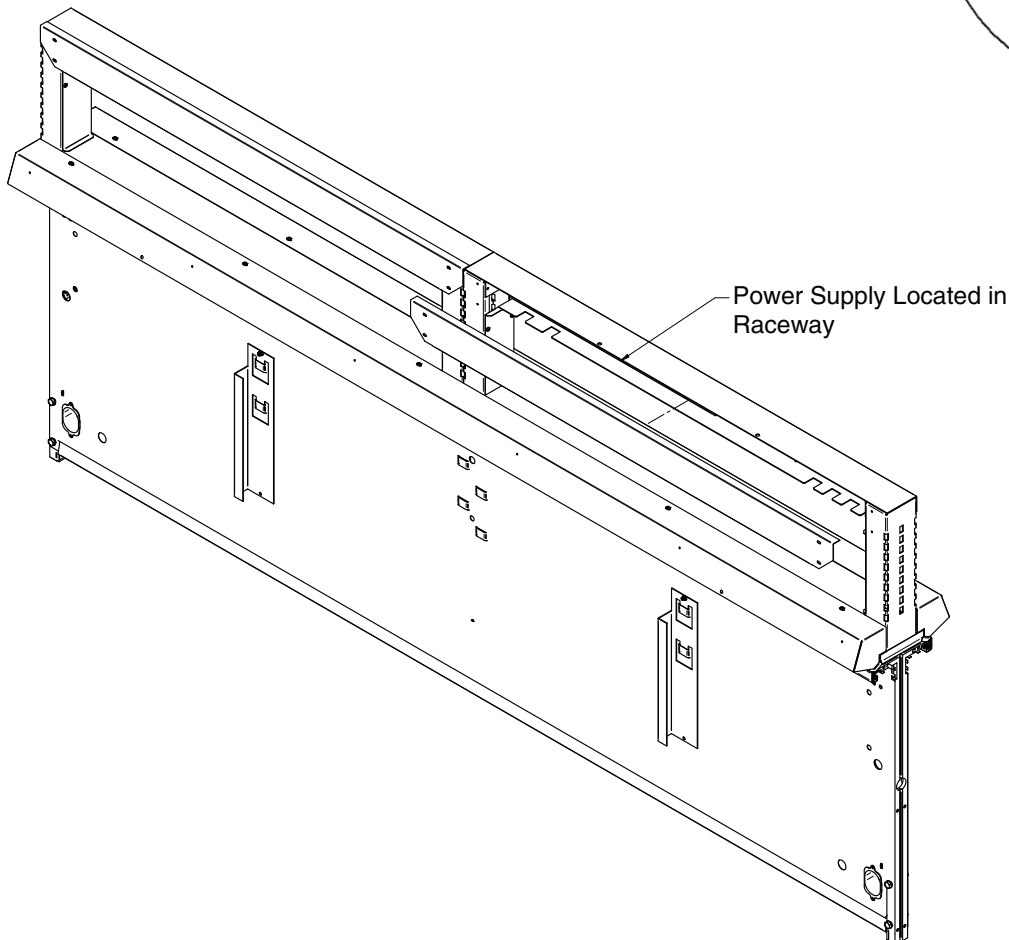

## REPAIRING ALUMINUM COIL

The aluminum coils used in Hussmann merchandisers may be easily repaired in the field. Materials are available from local refrigeration wholesalers.

Hussmann recommends the following solders and technique:

### Solders

Aladdin Welding Products Inc.

P.O. Box 7188

1300 Burton St.

Grand Rapids, MI 49507

Phone: 1-800-645-3413

Fax: 1-800-645-3414

X-Ergon

1570 E. Northgate

P.O. Box 2102

Irving, TX 75062

Phone: 1-800-527-9916

### NOTE:

Hussmann Aluminum melts at ..... 1125°F

Aladdin 3-in-1 rod at ..... 732°F

X-Ergon Acid core at ..... 455°F

### Technique:

1. Locate Leak.
2. REMOVE ALL PRESSURE.
3. Brush area UNDER HEAT.
4. Use PRESTOLITE TORCH ONLY. Number 6 tip.
5. Maintain separate set of stainless steel brushes, and USE ONLY ON ALUMINUM.
6. Tin surface around area.
7. Brush tinned surface UNDER HEAT, thoroughly filling the open pores around leak.
8. Repair leak. Let aluminum melt solder, NOT the torch.
9. Don't repair for looks. Go for thickness.
10. Perform a leak check.
11. Wash with water.
12. Cover with a good flexible sealant.

# **HUSSMANN<sup>®</sup>**

To obtain warranty information  
or other support, contact your Hussmann representative.

Please include the model and  
serial number of the product.

Hussmann Corporation, Corporate Headquarters: Bridgeton, Missouri, U.S.A.