

HUSSMANN®

Elite



Self-Service

Meat, Delicatessen, Dairy and Produce
Merchandisers



Installation & Operation Manual

Shipped With Case Data Sheets

IMPORTANT

**Keep in store for
future reference!**

MANUAL- I/O SELF SERVICE ELITE

HUSSMANN CORPORATION • BRIDGETON, MO 63044-2483 U.S.A.

P/N 0453523_G

Elite Series

August 2018

Spanish 0486358

French 0521924

TABLE OF CONTENTS

INSTALLATION

NSF Certification	1-1
Location	1-1
Shipping Damage	1-1
Apparent Loss or Damage	1-1
Concealed Loss or Damage	1-1
Exterior Loading	1-1
Merchandisers Shipped	
With End Installed	1-2
Shipping Braces	1-2
Leveling	1-2
Joining Instructions	1-3
Installing Bumpers	1-6
Installing Partitions	1-6

REFRIGERATION / ELECTRICAL

Refrigerant	2-1
Refrigerant Piping	2-1
Insulation	2-2
Suction Line	2-2
Liquid Line	2-2
Refrigeration Thermostat	2-3
Defrost Termination Thermostat	2-3
Defrost Sequences	2-3
Merchandiser Electrical Data	2-4
Electrical Connections	2-4
Field Wiring	2-4
Identification of Wiring	2-4

DRIP PIPING and LOWER PANELS

Waste Outlet and Water Seal	3-1
Installing Drip Piping	3-1
Installing Lower Front Panels	3-2

START UP / OPERATION

Start up	4-1
Load Limits	4-1
Stocking	4-2
Installing Shelves	4-3
Multi-deck Shelf Alignment	4-4
Multi-deck Shelf Configuration	4-4
Shelf Maximum Weight Limits	4-4
Installing Lighted Shelves	4-5
Procedure for Installing Lighted Shelves ..	4-6
Fluorescent Fixtures	4-8
Installing FDA/NSF Required Thermometer	4-8

MAINTENANCE

Care and Cleaning	5-1
Cleaning Honeycomb Assemblies	5-2
Removing Interior Back Panels	5-2
Cleaning Under Merchandisers	5-3
Cleaning Bumpers	5-3
Cleaning Prep Top	5-3
Cleaning Stainless Steel Surfaces	5-4
Maintaining Fluorescent Lamps	5-4

SERVICE

Replacing Fan Motors and Blades	6-1
Replacing LED Canopy Light Bars	6-2
Replacing LED Shelf Light Bars	6-2
Replacing LED Power Supplies	6-3
Replacing Fluorescent Lamps	6-4
Replacing Lamp Holders and End Caps ..	6-4
Replacing Electronic Ballasts	6-5
Replacing Damaged Drain Fitting	6-7
Repairing Aluminum Coils	6-8

WARRANTY

IMPORTANT
KEEP IN STORE FOR FUTURE REFERENCE

Quality that sets industry standards!

12999 St. Charles Rock Road • Bridgeton, MO 63044-2483

HUSSMANN®

U.S. & Canada 1-800-922-1919 • Mexico 1-800-890-2900

www.hussmann.com

© 2018 Hussmann Corporation

ANSI Z535.5 DEFINITIONS

! • DANGER – Indicate[s] a hazardous situation which, if not avoided, will result in death or serious injury.

! • WARNING – Indicate[s] a hazardous situation which, if not avoided, could result in death or serious injury.

! • CAUTION – Indicate[s] a hazardous situation which, if not avoided, could result in minor or moderate injury.

• NOTICE – *Not related to personal injury* – Indicates[s] situations, which if not avoided, could result in damage to equipment.



This warning does not mean that Hussmann products will cause cancer or reproductive harm, or is in violation of any product-safety standards or requirements. As clarified by the California State government, Proposition 65 can be considered more of a 'right to know' law than a pure product safety law. When used as designed, Hussmann believes that our products are not harmful. We provide the Proposition 65 warning to stay in compliance with California State law. It is your responsibility to provide accurate Proposition 65 warning labels to your customers when necessary. For more information on Proposition 65, please visit the California State government website.

REVISION HISTORY

REVISION F — AUGUST 2018

- 1. Proposition 65 Warning - supercedes prior Proposition 65 Warning

REVISION E — OCTOBER 2014

- 1. Proposition 65 Warning Page 1-1
- 2. no sealer on Drain Fitting, Page 6-7, note on 3-2

REVISION D — OCTOBER 2013

- 1. Added Caution box, page 1-1
- 2. Added *Maintaining Fluorescent Lamps*, page 5-4
- 3. Revised fluorescent canopy lamps, page 6-4
- 4. Removed obsolete LED illustrations from Section 6

REVISION C — OCTOBER 2012

- 1. Revised LED lighting instructions, page 4-5
- 2. Added Load Limit Profile Illustration, page 4-2
- 3. Added *Cleaning Coils*, page 5-3

REVISION B — AUGUST 2010

- 1. Added shelf weight limits table, page 4-3
- 2. Added wedge joining notice, page 1-3

REVISION A — FEBRUARY 2010

- 1. Updated electrical information, page 2-4
- 2. Revised drip piping pitch, page 3-1
- 3. Stainless steel cleaning info, page 5-3
- 4. Replacing LED lights, page 6-2; 6-3
- 5. Updated fluorescent lamp disposal, page 6-4
- 6. Added back page

INSTALLATION

NSF LISTING

These merchandisers are manufactured to meet ANSI / UL 471 standard requirements for safety. Proper installation is required to maintain this listing. Near the serial plate, each case carries a label identifying the type of conditions for which the merchandiser was tested.

ANSI/NSF-7 Type I – Display Refrigerator / Freezer Intended for 75°F / 55%RH Ambient Application

ANSI/NSF-7 Type II – Display Refrigerator / Freezer Intended for 80°F / 55%RH Ambient Application

ANSI/NSF-7 – Display Refrigerator Intended for Bulk Produce

FEDERAL / STATE REGULATION

These merchandisers, at the time they are manufactured, meet all federal and state / provincial regulations.

LOCATION

These merchandisers are designed for displaying products in air conditioned stores where temperature is maintained at or below the ANSI / NSF-7 specified level and relative humidity is maintained at or below 55%.

Placing refrigerated merchandisers in direct sunlight, near hot tables or near other heat sources could impair their efficiency.

Like other merchandisers, these are sensitive to air disturbances. Air currents passing around merchandisers will seriously impair their operation. **Do NOT** allow electric fans, air conditioning, open doors or windows, etc. to create air currents around merchandisers.

Product should always be maintained at proper temperature. This means that from the time the product is received, through storage, preparation

and display, the temperature of the product must be controlled to maximize the product life.

The exterior frames on these merchandisers provide space for air circulation. However, in high ambient conditions, sweating may still occur. If this happens install a method of forced ventilation such as a fan ventilation kit.

SHIPPING DAMAGE

All equipment should be thoroughly examined for shipping damage before and during merchandiser unloading.

This equipment has been carefully inspected at our factory. Any claim for loss or damage must be made to the carrier. The carrier will provide any necessary inspection reports and/or claim forms.

Apparent Loss Or Damage

If there is an obvious loss or damage, it must be noted on the freight bill or express receipt and signed by the carrier's agent; otherwise, carrier may refuse claim.

Concealed Loss Or Damage

When loss or damage is not apparent until after equipment is uncrated, retain all packing materials and submit a written request to the carrier for inspection, within 15 days.

EXTERIOR LOADING

Do NOT walk on top of merchandisers or damage to the merchandisers and serious personal injury could occur. THEY ARE NOT STRUCTURALLY DESIGNED TO SUPPORT EXTERNAL LOADING such as the weight of a person. Do not place heavy objects on the merchandiser.

MERCHANDISERS SHIPPED WITH END INSTALLED

Be careful not to damage the factory installed end while moving the case. Tools must be positioned past the end and beneath the merchandiser's support bar.

SHIPPING BRACES

Move the merchandiser as close as possible to its permanent location and then remove all packaging. Check for damage before discarding packaging. Remove all separately packed accessories such as kits and shelves.

! WARNING

Do NOT remove shipping braces until the merchandisers are positioned for installation.

NOTICE

Wedges are designed for proper operation when joined to a parent case. A wedge is not to be joined to another wedge.

Apply Silicone Gasket Pad

1. Apply a continuous bead of silicone around the front joining hole.

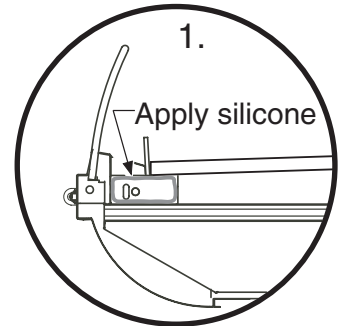

2. Remove paper backing from gasket pad and position the pad as shown.

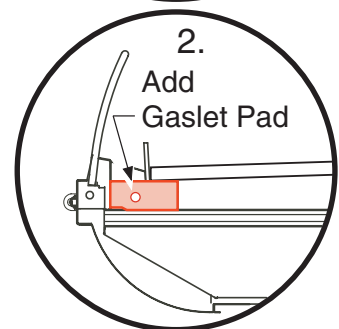

3. Apply another continuous bead of silicone on the gasket pad.

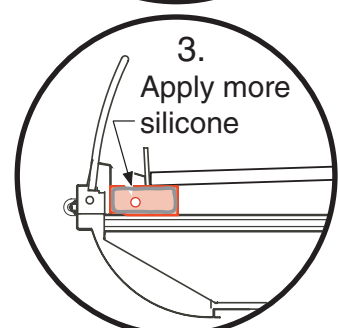

4. Apply foam gaskets as shown in detail and described on next page.

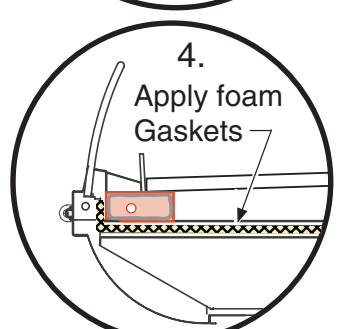

! WARNING

Do NOT stand or walk on top of merchandiser because. Do not place items or flammable materials atop the unit.

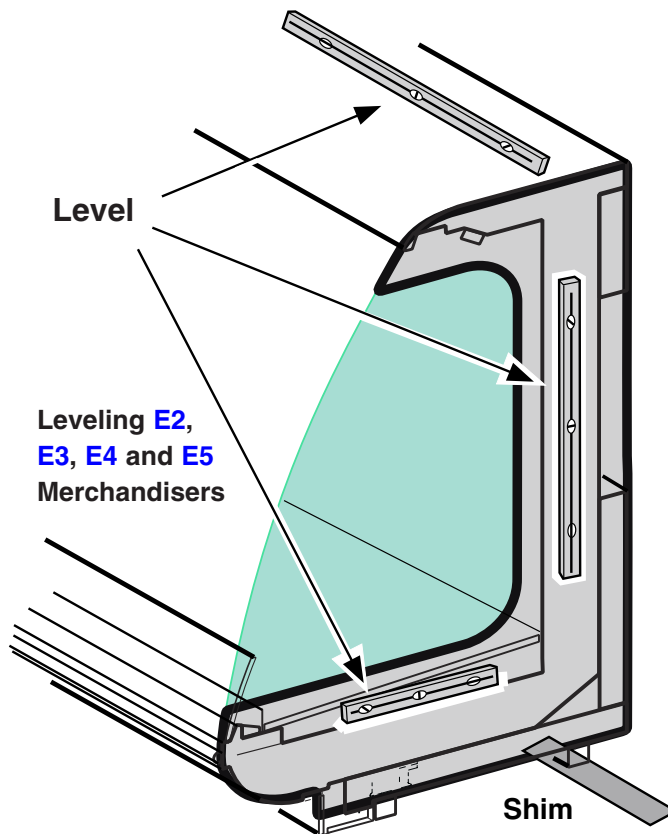
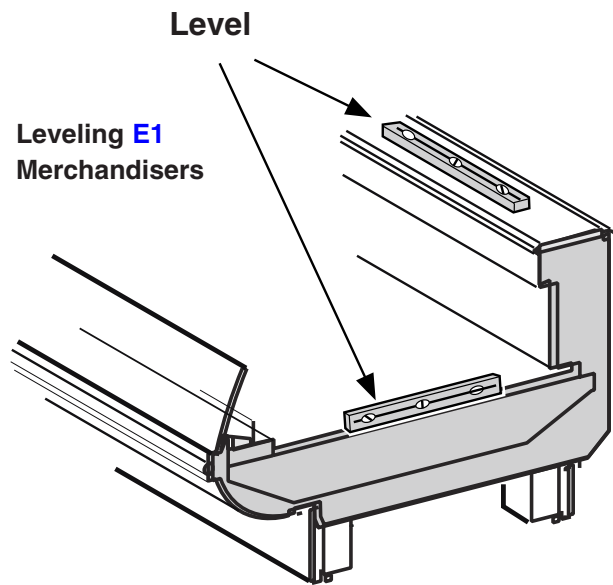

NOTE: Do not place levels on Display Pans or on Shelves.

1-4 INSTALLATION

Apply Gaskets

1. Apply $\frac{1}{2}$ in. (13 mm) gasket in the recess across the bottom and up the front of the merchandiser as shown. Gasket should cover slots.
2. Apply the $1\frac{5}{8}$ in. (41 mm) gasket to cover foam-to-metal gap at rear of case and across the top as shown. Be sure to lap gaskets as shown. Check to be sure that there are no gaps between gasket and merchandiser.

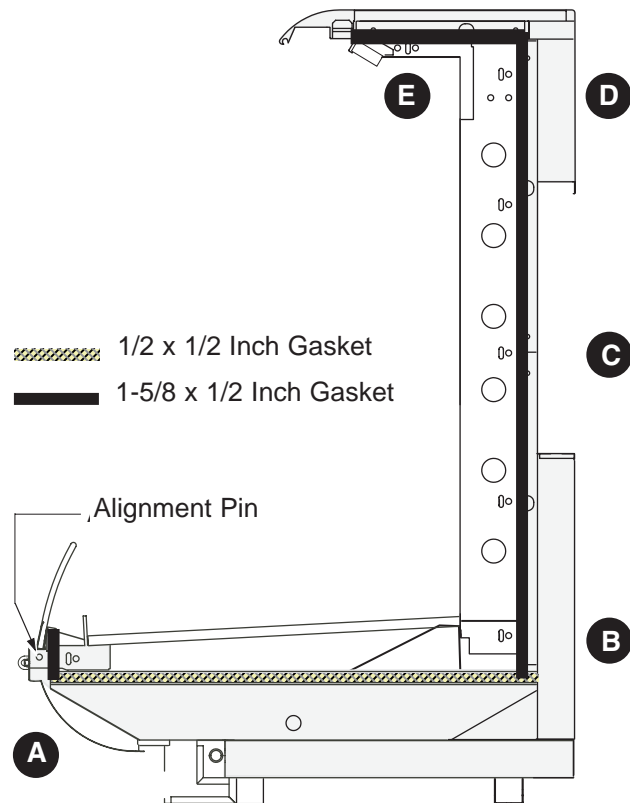

IMPORTANT

- Do not stretch gasket, especially around corners.
- Do not butt gaskets; always lap them as shown.
- Remove paper backing after gasket has been applied.

Tighten in Order Shown

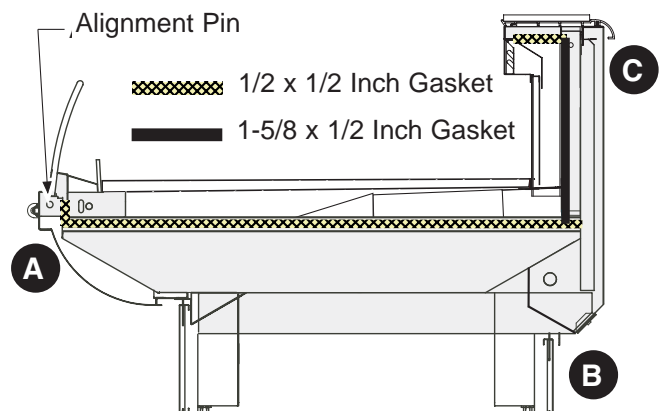

Insert Alignment Rod and Pins

1. Insert the alignment rod into the right end of the left case as indicated in the detail below. Verify alignment pins are properly seated in the left case.

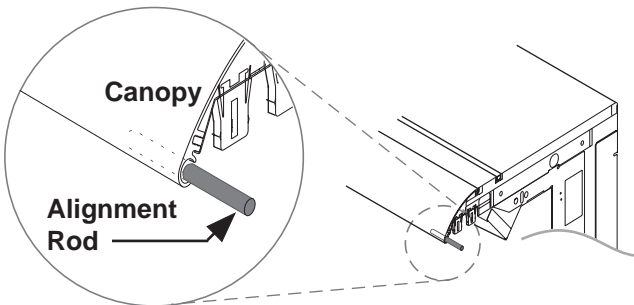

Fasten Cases

1. Move the second merchandiser into position against the first. Match the alignment rod and pin with the corresponding holes.
2. Fasten fronts together using cap screws, flat washers, lock washers and nuts. Tighten only until front panels touch. **Do not tighten fully.**
3. Use the cap screws, flat washers and lock washers provided in the joint kit to draw the merchandisers together at rear. **Do not tighten fully.**
4. Tighten joints in the order shown (A, B, C, D, E) until gaskets are compressed, and cases join smoothly.

Join Plexiglass

Parts List

- Acrylic Solvent Cement (IPS Weldon #40 or comparable, mixing instructions on product)
- Masking tape and duct tape (not supplied)

Instructions

1. Prepare front plexiglass for cement application by placing masking tape not more than $\frac{1}{16}$ in. (6 mm) from the seam, on both sides, front and back. Tape is to protect plexiglass from cement spill over. Scarring will occur if cement touches clear plexiglass.
2. Separate front plexiglass pieces enough to apply a bead of #40 cement down one edge inside of seam.
3. Apply cement with applicator to one or both surfaces. **Join immediately.**
4. Realign front plexiglass and push together tightly.
5. Apply just enough pressure to remove any air bubbles. Do not squeeze joint so hard as to force cement out of the joint—a dry joint may result.
6. Apply tape (2 in. duct tape recommended) across face of seam to secure plexiglass from shifting while cement dries.
7. Allow approximately 4 hours to dry at 70°F.

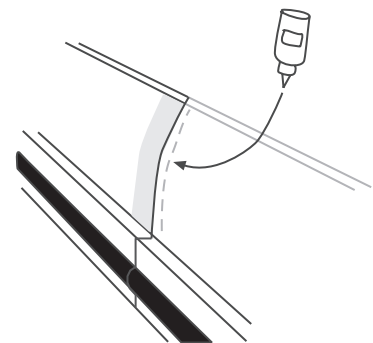

1-6 INSTALLATION

Seal Merchandisers

1. Apply butyl tape across the bottom joint. Be sure to extend the tape up the back and front of the case.
2. Use field-supplied silicone to fill any gaps between the front support brackets.

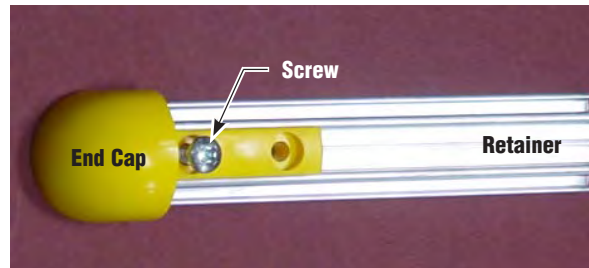
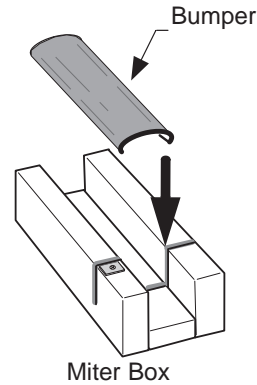
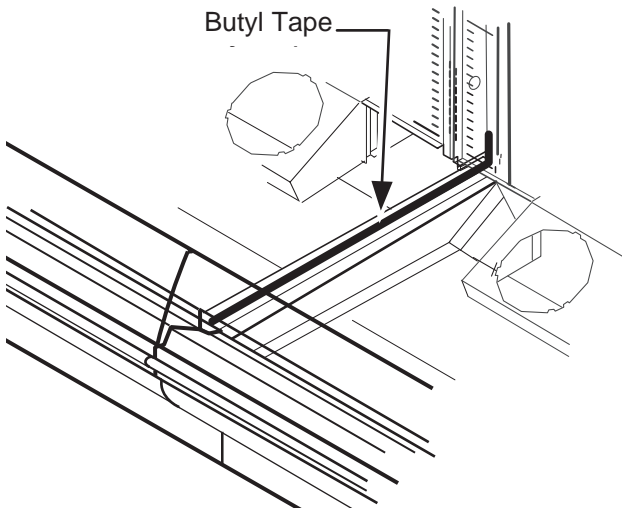

INSTALLING BUMPERS

Elite bumpers are shipped as a continuous roll. Once installed the continuous bumper helps to disguise the joint locations, giving the lineup a smoother look.

1. Unroll the bumper and allow it to rest at room temperature for **24 hours prior to installation** to minimize bumper shrinkage after installation.
2. Slide end caps onto retainer at right and left ends of lineup. Align with slot in retainer, then fasten with screws provided.
3. Measure the distance between inside end of caps and add $\frac{1}{8}$ inch (3 mm) for each 4 ft (1220 mm). Adding the additional material will compensate for stretching which occurs during installation.
4. Cut the bumper to length with a miter saw for a precise, right-angle cut.

5. Lubricate the inside of the vinyl with soapy water or silicone spray.
6. Starting at the left end of the line up, butt end of the vinyl bumper against end cap. While applying pressure, bend back vinyl top so that vinyl legs are positioned within the base grooves. Roll vinyl bumper over full length of retainer, then tap with rubber mallet to ensure vinyl is securely locked into retainer.
7. If necessary wipe clean with any household cleaning product.

INSTALLING PARTITIONS

To join same temperature fixtures on different defrost cycles, an acrylic partition kit is required.

To join unlike fixtures, or like fixtures operating at different temperatures, a 1 in. (26 mm) insulated connecting partition kit is required.

Instructions for installing these partitions are included with the kits.

REFRIGERATION / ELECTRICAL

REFRIGERANT

The correct type of refrigerant will be stamped on each merchandiser's serial plate. The case refrigeration piping is leak tested, factory sealed and pressurized. Before making refrigeration hookups, depress the universal line valve to ensure that coils have maintained pressure during shipment.

! WARNING

**Refrigeration lines are under pressure.
Refrigerant must be recovered before
attempting to make any connections.**

REFRIGERANT PIPING

Connection Location

The refrigerant line connections are at the right-hand end of the merchandiser (as viewed from the front) beneath the display pans. A sticker marks the location of the connection "pod." The installer must saw a hole through the pod to exit the merchandiser.

After connections have been made, seal this outlet thoroughly. Seal both the inside and the outside. We recommend using an expanding polyurethane foam insulation.

Multiplexing

Piping of merchandisers that are operating on the same refrigeration system may be run from merchandiser to merchandiser. **DO NOT RUN REFRIGERANT LINES THROUGH MERCHANDISERS THAT ARE NOT ON THE SAME REFRIGERATION SYSTEM BRANCH** as this may result in poor refrigeration control and compressor failure. Interconnecting piping inside the merchandiser must be located as shown below to allow room for lifting the hinged fan plenums and for clearance beneath the display pans. Or the interconnecting piping may be run outside the case in the raceway area shown.

! WARNING

When brazing pipes, be sure to use the insulation blanket shipped with the merchandiser to prevent damage to the plastic merchandiser bottom.

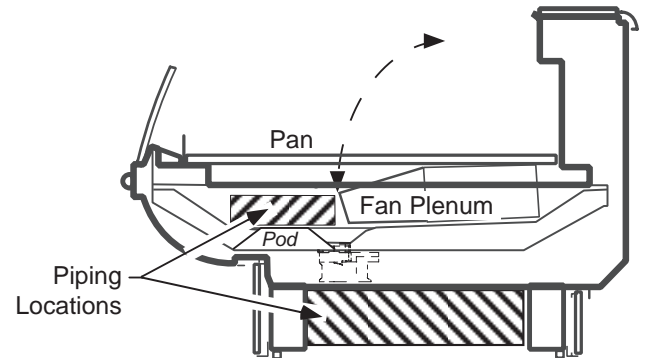

Line Sizing

Refrigerant lines should be sized as shown on the refrigeration legend that is furnished for the store or according to ASHRAE guidelines. Refer to the information on the next page for branch line piping of Hussmann Equipment.

Oil Traps

P-traps (oil traps) must be installed at the base of all suction line vertical risers.

Pressure Drop

Pressure drop can rob the system of capacity. To keep the pressure drop to a minimum, keep the refrigerant line run as short as possible using a minimum number of elbows. Where elbows are required, USE LONG RADIUS ELBOWS ONLY.

INSULATION

The suction and liquid lines should be clamped or taped together and insulated for a minimum of 30 ft (9144 mm) from the merchandiser. Additional insulation for the balance of the liquid and suction lines is recommended wherever condensation drippage is objectionable or lines are exposed to ambient conditions.

SUCTION LINE

- Pitch in direction of flow.
- May be reduced by one size at one third of case run load and again after the second third. Do not reduce below the case suction line size.
- Case suction lines should enter at the top of the branch line.

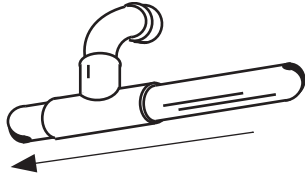

Suction Line Return

LIQUID LINE

- May be reduced by one size after one half the case run load. Do not reduce below the case liquid line connection size.
- Take-offs to case liquid lines should exit the bottom of the branch liquid line. Provide an expansion loop for each evaporator take-off (minimum 3 in. [76 mm] loop).

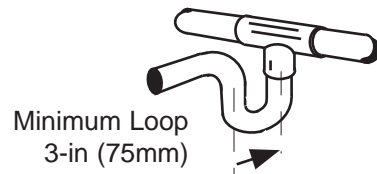

Liquid Line Take Off

Offtime Defrost

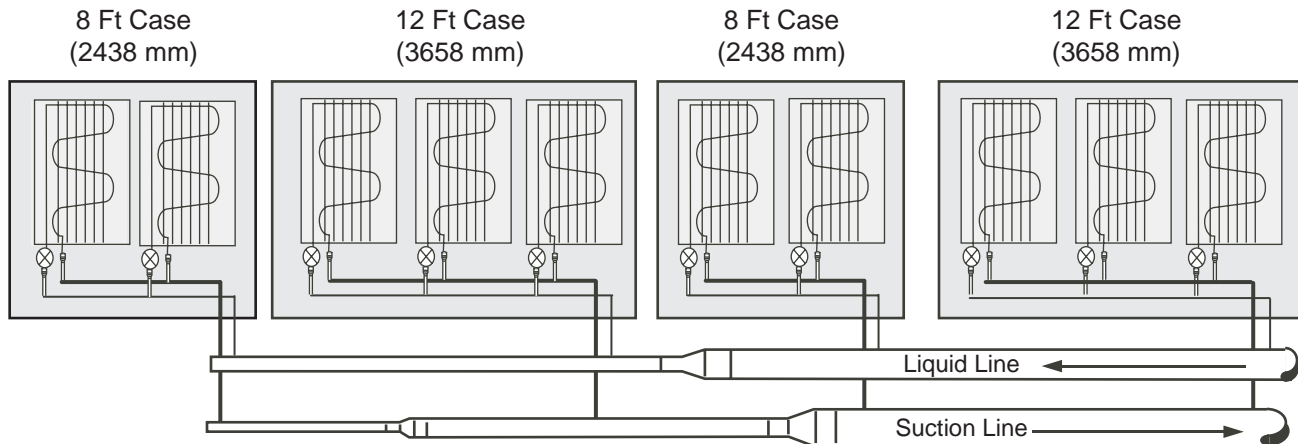

REFRIGERATION THERMOSTAT

The bulb for the optional refrigeration thermostat is located approximately 12 in. (305 mm) above the coil and 6 ft (1829 mm) from the left-hand end (facing front) of the merchandiser. The optional refrigeration thermostat is located 5 ft (1524 mm) from the left-hand end, just past the raceway.

DEFROST TERMINATION THERMOSTAT

The standard disc type defrost termination thermostat is not adjustable. This thermostat is clamped to the suction line of the coil on the left-hand (facing front) end of the merchandiser.

DEFROST SEQUENCES

These merchandisers require defrost cycles for proper operation. Refer to the data sheets for application data.

The Time Clock initiates defrost. The evaporator fans continue to circulate air across the evaporator coil, melting any frost build-up. Defrost can be terminated by either temperature or time.

Temperature Termination

Temperature termination should be used for the following types of installations:

1. Parallel systems with EPRs or suction stop solenoids
2. Single compressor units without pump-down cycle.

Time Termination

Should be used for the following types of installations:

1. Parallel systems with thermostat and liquid solenoid.
2. Single compressor units with pump-down.

To use time termination, simply do not wire the termination thermostat.

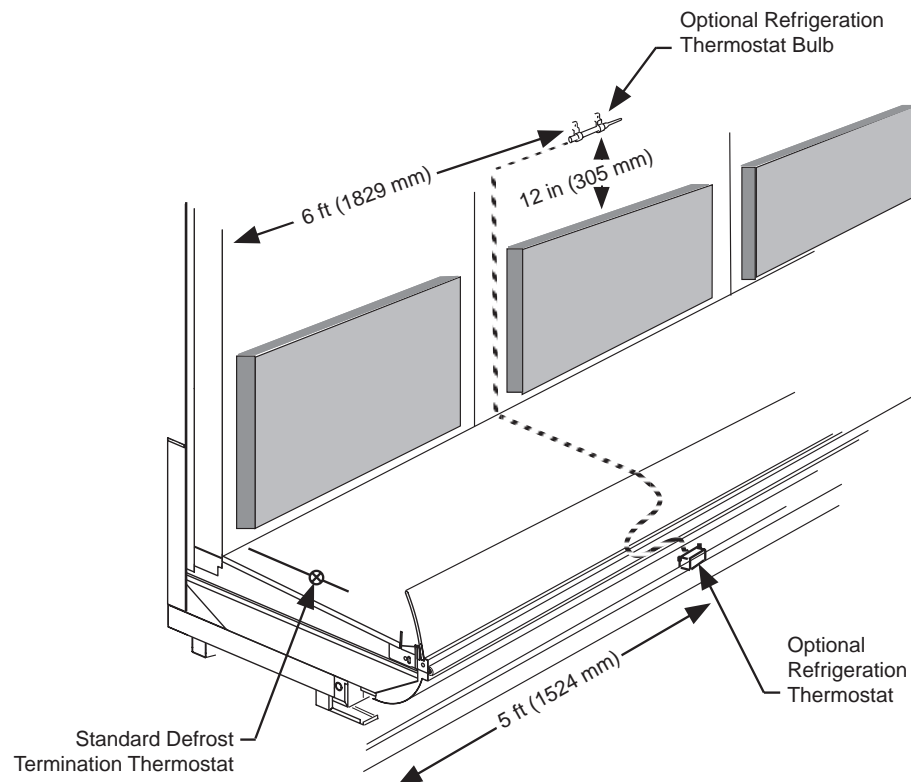

MERCHANDISER ELECTRICAL DATA

Merchandiser data sheets are included with this manual. The data sheets provide case electrical data, electrical schematics, parts lists and performance data. Refer to the merchandiser data sheets and case serial plate for electrical information.

ELECTRICAL CONNECTIONS

All wiring must be in compliance with NEC and local codes. All electrical connections are to be made in the electrical raceway or *Handy Box*.

FIELD WIRING

Field wiring must be sized for component amperes stamped on the serial plate. Actual ampere draw may be less than specified. Field wiring from the refrigeration control panel to the merchandisers is required for defrost termination thermostats and for optional refrigeration thermostats. When multiple merchandisers are on the same defrost circuit, the defrost termination thermostats are wired in series. **ALWAYS CHECK THE SERIAL PLATE FOR COMPONENT AMPERES.**

IDENTIFICATION OF WIRING

Leads for all electrical circuits are identified by colored plastic bands. These bands correspond to the *color code sticker* (shown below) located inside the merchandiser's raceway.

 **WARNING**

Optional T8 rail lights and optional Quick Connect spray hose or field-installed misting system shall not be used together.

WIRING COLOR CODE

Leads for all electrical circuits are identified by a colored plastic band: neutral wire for each circuit has either White insulation or a White plastic sleeve in addition to the color band.

<p>PINK REFRIG. THERMOSTAT LOW TEMP.</p> <p>LIGHT BLUE. REFRIG. THERMOSTAT NORM TEMP.</p> <p>DARK BLUE. DEFROST TERM. THERMOSTAT</p> <p>PURPLE..... CONDENSATE HEATERS</p> <p>BROWN FAN MOTORS</p> <p>GREEN* GROUND</p>	<p>ORANGE OR TANLIGHTS</p> <p>MAROON ..RECEPTACLES</p> <p>YELLOW ...DEFROST HEATERS 120V</p> <p>REDDEFROST HEATERS 208V</p> <p>*EITHER COLORED SLEEVE OR COLORED INSULATION</p>
---	--

ELECTRICIAN NOTE: Use copper conductor wire only.

CASE MUST BE GROUNDED

THESE ARE MARKER COLORS WIRES MAY VARY.

DRIP PIPING AND LOWER PANELS

WASTE OUTLET AND WATER SEAL

The waste outlet is located in front of the fan plenum 6 ft (1829 mm) from the left-hand end of the merchandiser (facing case front). A water seal is supplied with each fixture. The water seal must be installed to the waste outlet to prevent air leakage and insect entrance into the merchandiser.

NOTE:

Water seal outlet must clear front skid rail.

A Tee, adapter, plug and street ell are also supplied with each merchandiser.

INSTALLING DRIP PIPING

Poorly or improperly installed drip pipes can seriously interfere with the merchandiser's operation and result in costly maintenance and product losses. Please follow the recommendations listed below when installing drip pipes to ensure proper installation.

1. Never use drip piping smaller than the nominal diameter of the pipe or water seal supplied with the merchandiser.
2. When connecting drip piping, the "water seal" must be used as part of the drip piping to prevent air leakage or insect entrance. Never use two water seals in series in any one drip pipe. **DOUBLE WATER SEALS IN SERIES WILL CAUSE AN AIR LOCK AND PREVENT DRAINING.**
3. Pitch the drip piping in the direction of flow. There should be a minimum pitch of 1/4 inch per foot (20 mm per 1 m).
4. Avoid long runs of drip piping. Long runs make it impossible to provide the pitch necessary for good drainage.

CAUTION

Splashguard brackets MUST be installed before piping merchandiser.

5. Provide a suitable air break between flood rim of the floor drain and outlet of drip pipe. To meet code on low base merchandisers, it may be necessary to install a field-supplied drip pipe reducer. An alternative is to cut the last section of drip pipe at an angle.
 

6. Prevent drip pipes from freezing:
 - A. Do NOT install drip pipes in contact with uninsulated suction lines. Suction lines should be insulated with a non-absorbent insulation material.
 - B. Where drip pipes are located in dead air spaces, such as between merchandisers or between a merchandiser and a store wall, provide means to prevent freezing.

Do not apply pipe thread sealer to ABS drain fitting or the fitting may crack or become damaged.

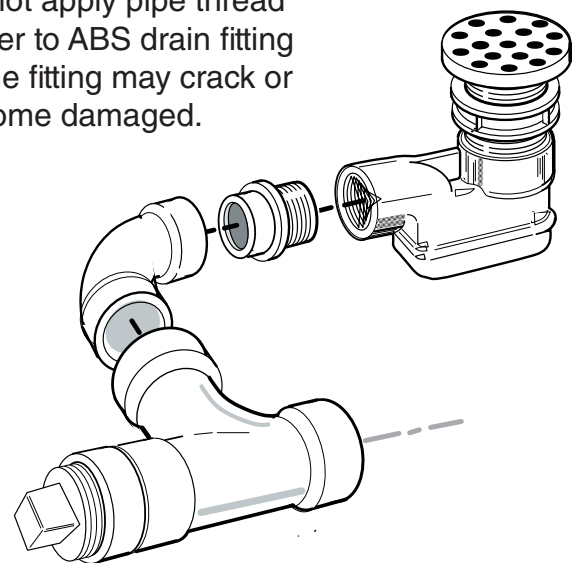

INSTALLING LOWER FRONT PANELS

The lower front panels are shipped inside each merchandiser. **AFTER** merchandisers have been leveled and joined, and all drip piping, electrical and refrigeration work has been completed, install the lower front panel.

To Install Lower Front Panel

1. The lower front panel supports are designed to fit into the slots on the top of the lower front panel.
2. Once the top is positioned, lift the panel up and drop it over the tabs on the front close-off brackets.

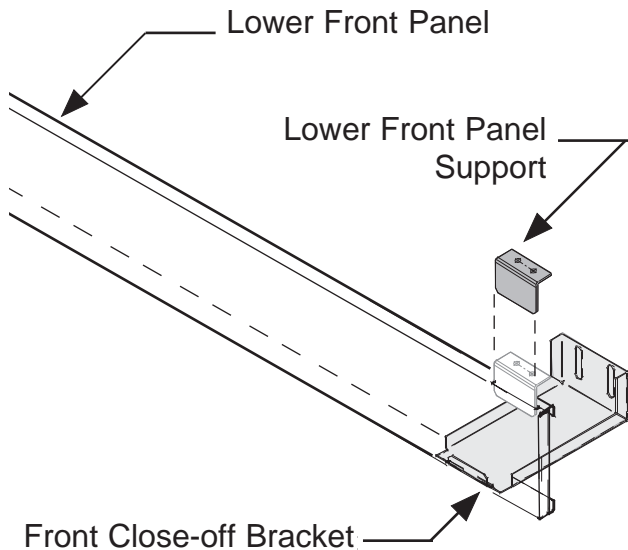

Space between the Lower Front Panel and the floor may be covered using a vinyl cove base trim (field supplied). The size of trim needed will depend on how much the floor is out of level.

To install the trim to the front panel:

1. Remove all dirt, wax and grease from the area of the lower front panel where adhesion will be necessary. This is to ensure a good and secure installation.
2. Apply a good contact cement to the cove trim and allow proper drying time according to the directions supplied with the cement.
3. Install the trim on the lower front panel so that it is lying flush with the floor. **DO NOT SEAL THE TRIM TO THE FLOOR.**
4. **If required by local health codes** the Cove Trim may be sealed to the floor, using a silicone type sealer. Sealant must be removed and replaced when servicing.

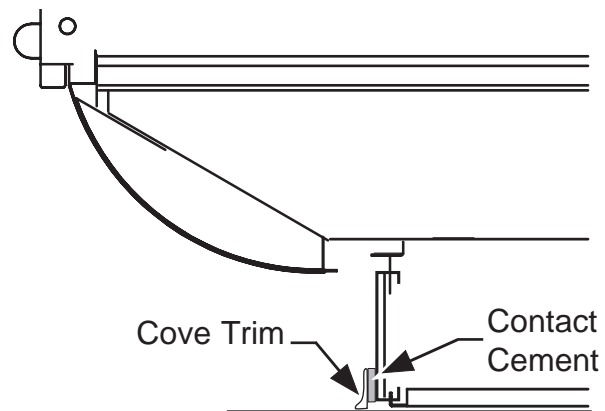

START UP / OPERATION

START UP

See the merchandiser's Data Sheet Set for refrigerant settings and defrost requirements. Bring merchandisers down to the operating temperatures listed on the data sheet.

Each four foot section has its own evaporator coil and pre-set non-adjustable thermostatic expansion valve (TEV). No adjustment is required. **DO NOT REMOVE THE CAP ON THE TEVs.** This cap is to be removed only for valve disassembly. Removal of this cap during case maintenance will result in refrigerant loss unless the system is first isolated and the refrigerant recovered.

The TEV has been factory set to provide the recommended performance settings as specified on the merchandiser data sheets.

 CAUTION
Removal of the TEV cap will result in refrigerant loss unless the system is first isolated and the refrigerant recovered.

LOAD LIMITS

Each merchandiser has a load limit decal. Shelf life of perishables will be short if load limit is violated.

AT NO TIME SHOULD MERCHANDISERS BE STOCKED BEYOND THE LOAD LIMITS INDICATED.

DO NOT BLOCK HONEYCOMB OR RETURN AIR GRILLE.





WARNING

— LOCK OUT / TAG OUT —

To avoid serious injury or death from electrical shock, always disconnect the electrical power at the main disconnect when servicing or replacing any electrical component. This includes, but is not limited to, such items as doors, lights, fans, heaters, and thermostats.

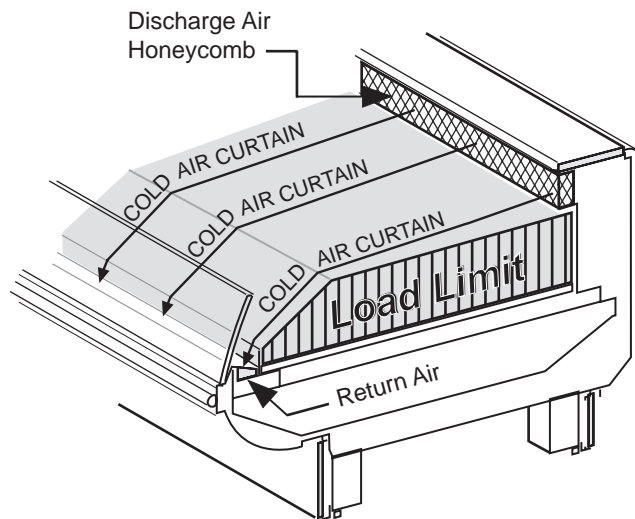
CORRECT



WRONG

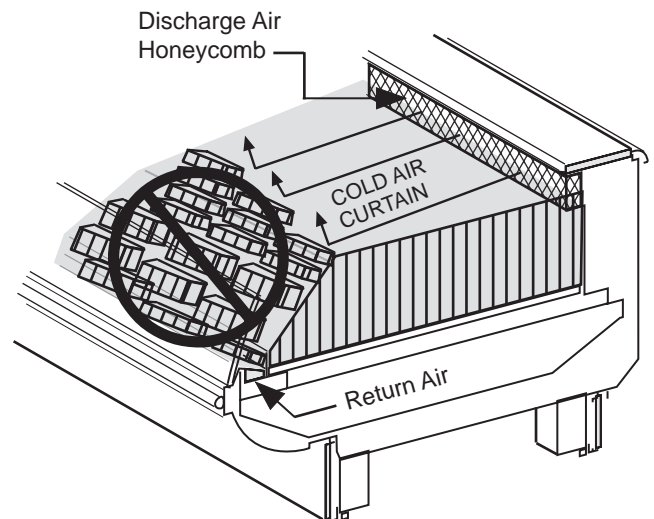

DO NOT OVER STOCK MERCHANDISER

STOCKING

Product should NOT be placed in merchandisers until case is at proper operating temperature.

Proper rotation of product during stocking is necessary to prevent product loss. Always bring the oldest product to the front and set the newest to the back.

AIR DISCHARGE AND RETURN FLUES MUST REMAIN OPEN AND FREE OF OBSTRUCTION AT ALL TIMES to provide proper refrigeration and air curtain performance. Do not allow product, packages, signs, etc. to block these grilles. Do not use non-approved shelving, baskets, display racks, or any accessory that could hamper air curtain performance.

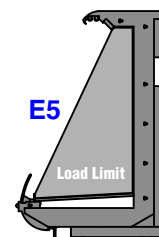
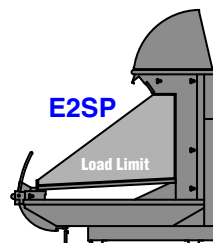
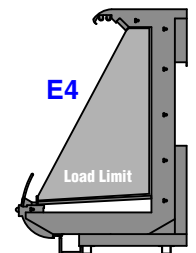
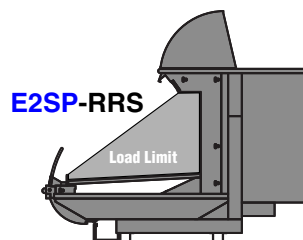
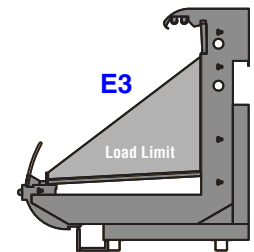
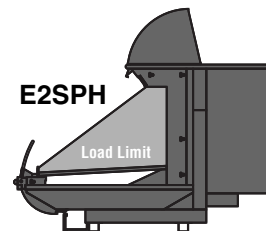
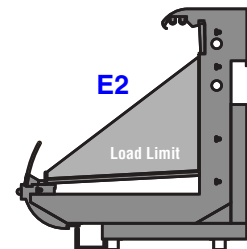
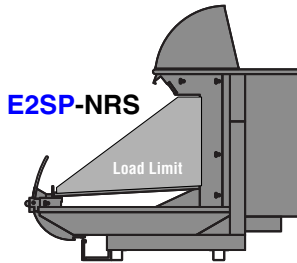
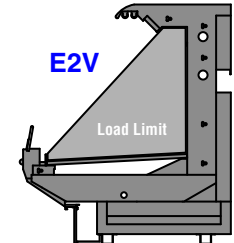
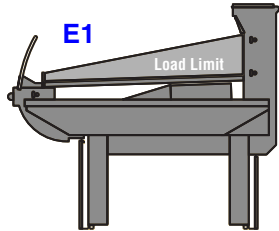
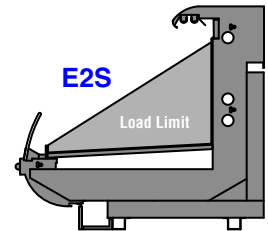
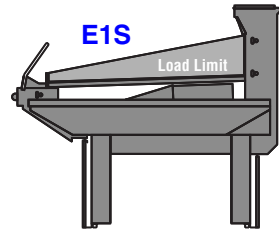
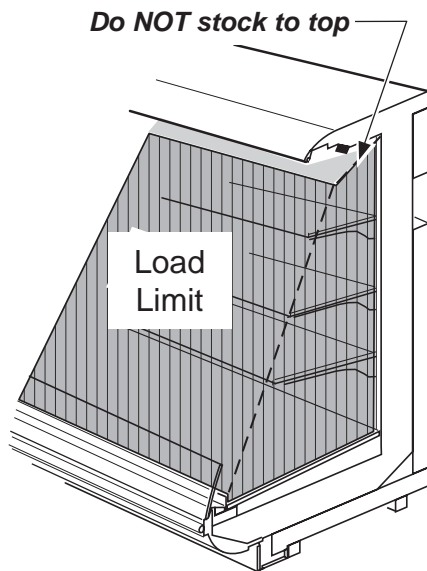

⚠ WARNING

At no time should merchandisers be stocked beyond the load limits indicated. Improper stocking can cause poor performance that results in spoiled food.

INSTALLING SHELVES

Begin with the lowest row of shelves. Verify the shelf brackets are at 90 degrees to shelf. Keep shelf level from side to side while tilting the front down to insert the lowest tab in the shelf upright. Use a level on each shelf, or count slots in each upright and mark with tape to ensure rows of shelves stay level. Tabs must be seated firmly into position in the uprights before loading shelves.

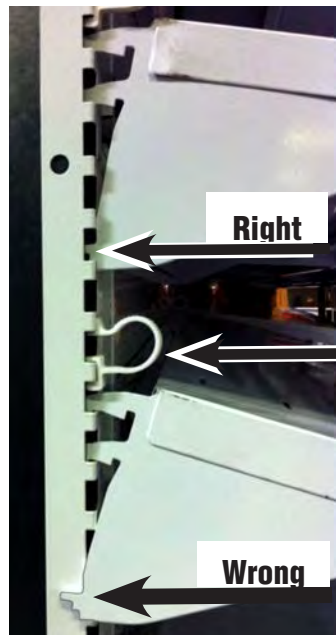
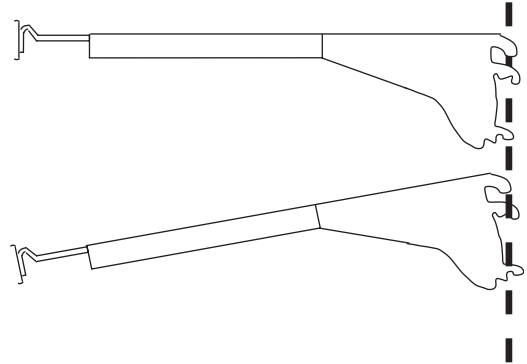

Remove Shipping Clips



Even Vertical Spacing in Upright



Uneven Vertical Spacing in Upright

**MULTI-DECK SHELF ALIGNMENT
(Optional Shelf Alignment Strips)**

Taped to one of the shelves of each merchandiser is a small plastic bag containing shelf alignment strips. These strips are designed to enhance the appearance of the shelves by aligning the front edge of each shelf with that of an adjacent shelf.

When installing shelves:

1. Insert one of the alignment strips into the slot behind the front edge of each shelf.
2. After all shelves are installed, slide the strip across the shelf joint wherever two shelves are adjacent. This will lock them together.

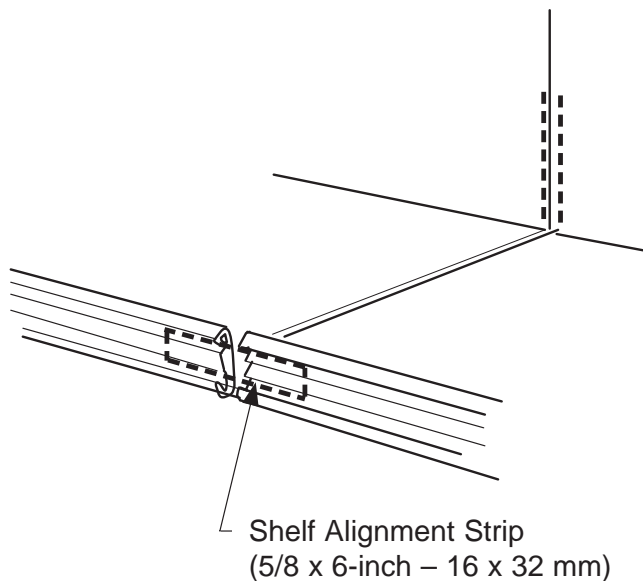

SHELF MAXIMUM WEIGHT LIMITS

Hussmann merchandiser shelves are designed to support the maximum weight load limits as indicated in the table below. Exceeding these maximum weight load limits may cause damage to the shelf or shelves, damage to the merchandiser, damage to store products, and potentially create a hazardous condition for customers and staff.

Exceeding the indicated maximum weight load limits constitutes misuse as described in the Hussmann Limited Warranty.

Weight Limits for Merchandiser Shelving

Nominal Shelf Depth	Maximum Load Limit
10 in. (254 mm)	125 lb (56.7 kg)
12 in. (305 mm)	125 lb (56.7 kg)
14 in. (357 mm)	125 lb (56.7 kg)
16 in. (406 mm)	200 lb (90.7 kg)
18 in. (457 mm)	200 lb (90.7 kg)
20 in. (508 mm)	250 lb (113.4 kg)
22 in. (559 mm)	250 lb (113.4 kg)

*Shelf load limits at 0° tilt

LED LIGHT FIXTURES

If your merchandiser has LED fixtures (light emitting diode), the procedure for installing the lighted shelves is the same. However, instead of ballasts that run fluorescent lamps, your merchandiser is equipped with 24VDC power supply that provides DC power to operate the LEDs. EcoShine II LED lights work well for dimming or on/off operation using an occupancy sensor (optional kits).

They can be turned on and off in a cold environment with no warm-up time and no negative impact on lamp life. Hussmann EcoShine II LED light fixtures normally perform for up to 50,000 hours.

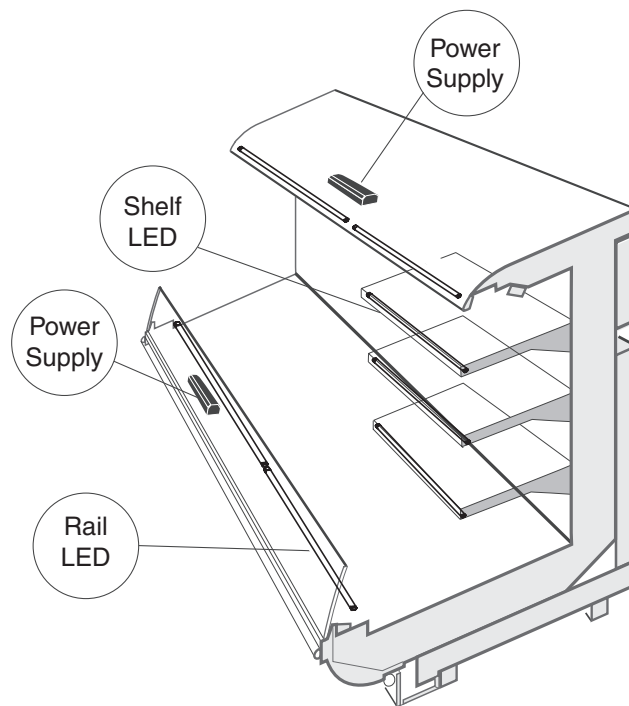

Elite (E3) Shown



LED Shelf Light Plug



LED Shelf Light Receptacle

PROCEDURE FOR INSTALLING LIGHTED SHELVES

Follow these instructions to ensure good contact between male and female connectors.

1. Remove produce from shelf and place in cooler.

SHUT OFF POWER TO THE MERCHANDISER.

2. Turn off Canopy Light Switch. Remove all packed shelves.
3. Remove shelf connectors from power sockets. Always grip shelf connector by the handle when removing from socket. **PULL handle DOWN AND THEN OUT to disengage.** Note that latch tongue must depress to disengage plug.



**Fluorescent
Shelf Light
Plug**



**Fluorescent
Shelf Light
Receptacle**

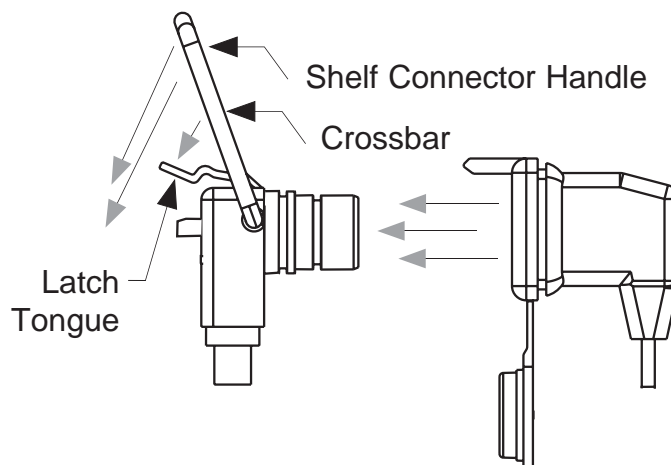

4. **Engage each power socket cap and ensure that each cap is fully seated before cleaning.** Ensure the proper seating of the cap at all times when the plug is not engaged.



5. Clean the merchandiser as described in the **Care and Cleaning** paragraphs of *Section 5 – Maintenance*. **Keep liquid out of sockets.**
6. Verify that power is at the merchandiser and turned on. Verify that the merchandiser light switch is turned “OFF.” Switch is located in the canopy, on the left, behind first row of lamps.

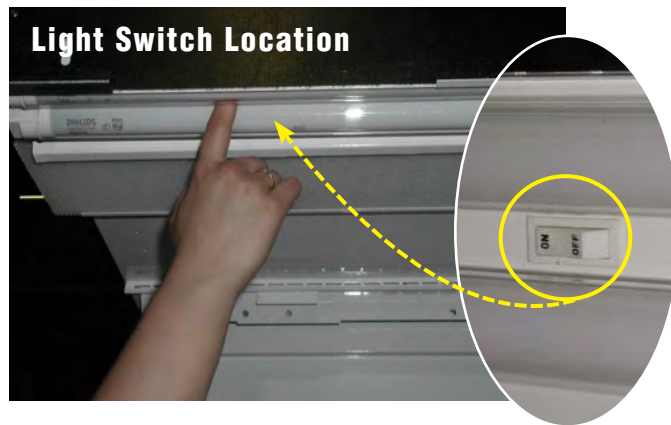

7. Note that some models have fewer rows of shelves. Starting from the left-hand bottom section, choose the location for the first shelf. Secure the shelf in the slotted upright. **It is important that shelf brackets be properly seated in the slotted upright.**
8. Turn “ON” the merchandiser light switch after all rows are installed.

Note: LED lamps use a 24VDC power supply. If a shelf fluorescent light does not operate:

- A. Turn off light switch.
- B. Make certain the shelf lamps are properly engaged in the shelf lamp holders.
- C. Remove and firmly re-insert each shelf plug.
- D. Turn on light switch.

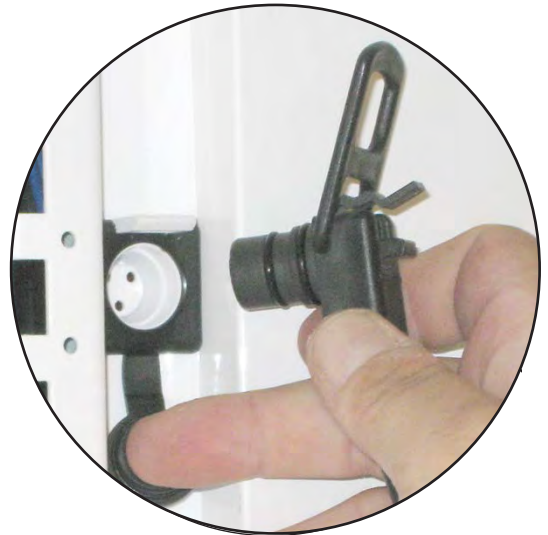

Shelf Socket

FLUORESCENT FIXTURES

The ballasts used in Excel models have built-in anti-arc protection. An electrical arc may occur if a shelf plug is not seated properly, or if a lamp is not properly seated in a lampholder. The ballast will shut down when it detects an arc.

Two to four lamps will be out in the merchandiser when this occurs. Carefully check the plugs to make sure they are fully seated, and check the lamps to ensure they are firmly seated in the lamp-holders on the affected shelves.

To reset a ballast that has ‘tripped’ on anti-arc, turn off the merchandiser light switch for a minimum of 15 seconds, then turn it on.

Note:

The ballasts used in *Elite* models have built-in anti-arc protection. An electrical arc may occur if a shelf plug is not seated properly, or if a lamp is not properly seated in a lampholder.

The ballast will shut down when it detects an arc. Two to four lamps will be out in the merchandiser when this occurs. Carefully check the plugs to make sure they are fully seated, and check the lamps to ensure they are firmly seated in the lamp-holders on the affected shelves.

To reset a ballast that has ‘tripped’ on anti-arc, turn off the merchandiser light switch for a minimum of 15 seconds, then turn it on.

WARNING

— LOCK OUT / TAG OUT —

To avoid serious injury or death from electrical shock, always disconnect the electrical power at the main disconnect when servicing or replacing any electrical component. This includes, but is not limited to, such items as doors, lights, fans, heaters, and thermostats.

INSTALLING FDA/NSF REQUIRED THERMOMETER

The following pages provide the same information that ships with the thermometer.

This requirement does not apply to display refrigerators intended for bulk produce (refer to page 1-1).

Please note that the tape cannot be exposed after installation.

This is an NSF-7 & US FDA Food Code Required Thermometer

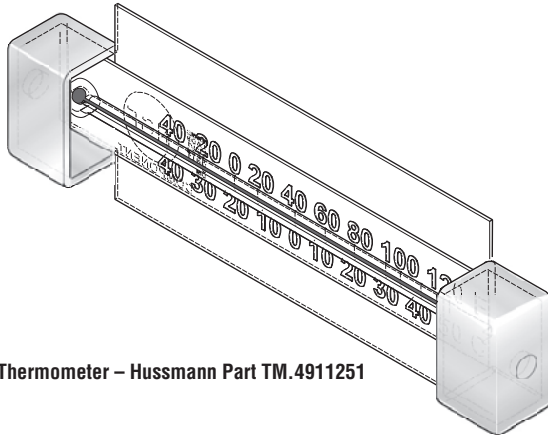

Thermometer – Hussmann Part TM.4911251

Hussmann Corporation • 12999 St. Charles Rock Road • Bridgeton, MO 63044-2483
U.S. & Canada 1-800-922-1919 • Mexico 1-800-522-1900 • www.hussmann.com
© 2007 Hussmann Corporation

Suggested Mounting Locations in Single Deck Glass Front Impact Merchandisers

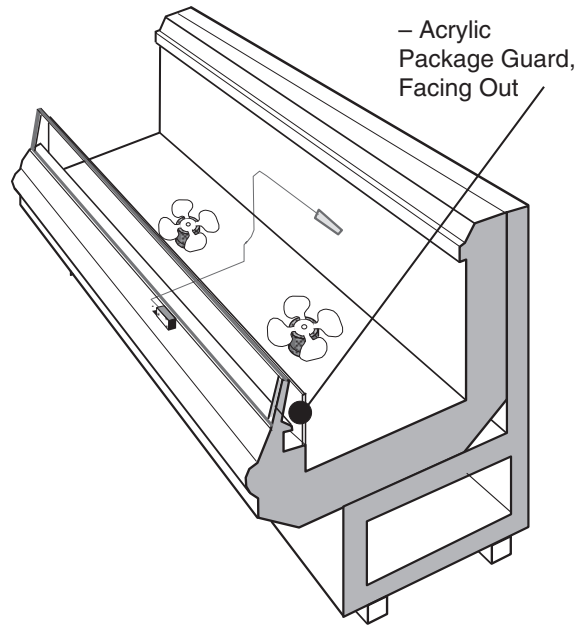

– Acrylic Package Guard, Facing Out

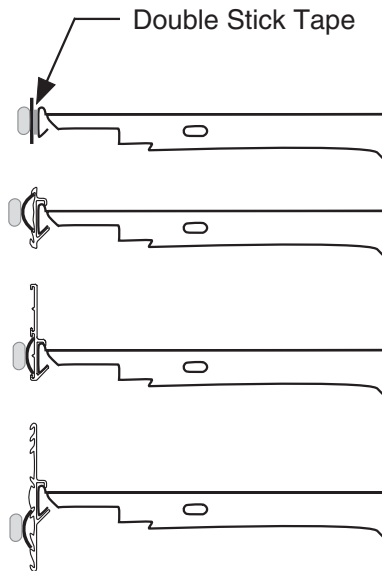

Double Stick Tape

Flexible Plastic Fits in Price Tag Moldings

Hussmann P/N 0429971_C

10/2007

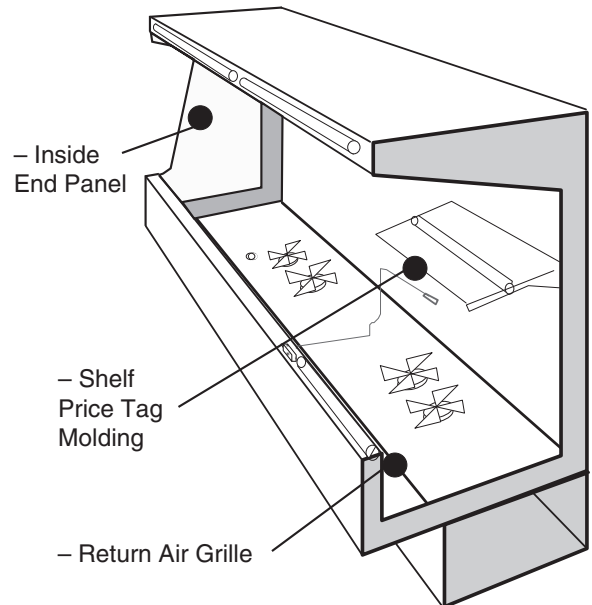

– Inside End Panel

– Shelf Price Tag Molding

– Return Air Grille

Suggested Mounting Locations in Multi-deck Merchandisers

Important – Please read!

This thermometer is provided in response to United States Food and Drug Administration (US FDA) Food Code [<http://www.fda.gov/>] and National Sanitation Foundation (NSF / ANSI) Standard 7 [<http://www.nsf.org/>]

Each installation will be different depending on how the unit is stocked, shopping patterns in the department and ambient conditions of the store. The suggested locations provided herein are possible locations. It is the responsibility of the purchaser / user to determine the location with the food storage area of the unit that best meets the code requirements above.

The thermometer may need to be moved several times to find the warmest location. Mounting options include flexible plastic for price tag molding application, magnet applied to back of flexible plastic for steel end wall, and double stick tape. Tape must not be exposed after installation.

Questions about either code should be addressed to local agencies or other appropriate officials.

**Keep with merchandiser
or give to store manager.**

DO NOT DESTROY.

MAINTENANCE

CARE AND CLEANING

Long life and satisfactory performance of any equipment is dependent upon the care it receives. To ensure long life, proper sanitation and minimum maintenance costs, these merchandisers should be thoroughly cleaned, all debris removed and the interiors washed down, weekly.

Fan Plenum

To facilitate cleaning, the fan plenum is hinged. After cleaning be sure the plenum is properly lowered into position OR PRODUCT LOSS WILL RESULT due to improper refrigeration.



Exterior Surfaces

The exterior surfaces must be cleaned with a mild detergent and warm water to protect and maintain their attractive finish. **NEVER USE ABRASIVE CLEANSERS OR SCOURING PADS.**

Interior Surfaces

The interior surfaces may be cleaned with most domestic detergents, ammonia based cleaners and sanitizing solutions with no harm to the surface.

Do NOT Use:

- Abrasive cleansers and scouring pads, as these will mar the finish.
- A hose on lighted shelves or submerge the shelves in water.
- Solvent, oil or acidic based cleaners on any interior surfaces.
- A hose on rail lights, canopy lights or any other electrical connection.

Do:

- Remove the product and all loose debris to avoid clogging the waste outlet.
- Store product in a refrigerated area such as a cooler. Remove only as much product as can be taken to the cooler in a timely manner.
- First turn off refrigeration, then disconnect electrical power.**
- Thoroughly clean all surfaces with soap and hot water. **DO NOT USE STEAM OR HIGH WATER PRESSURE HOSES TO WASH THE INTERIOR. THESE WILL DESTROY THE MERCHANDISERS' SEALING CAUSING LEAKS AND POOR PERFORMANCE.**
- Lift hinged fan plenum for cleaning. Hook chain in rear panel to secure plenum during cleaning. **BE SURE TO REPOSITION THE FAN PLENUM AFTER CLEANING MERCHANDISER.**
- Take care to minimize direct contact between fan motors and cleaning or rinse water.
- Rinse with hot water, but do NOT flood. **NEVER INTRODUCE WATER FASTER THAN THE WASTE OUTLET CAN REMOVE IT.**
- Allow merchandisers to dry before resuming operation.
- Wipe down lighted shelves with a damp sponge or cloth so that water does not enter the light channel. **DO NOT USE A HOSE OR SUBMERGE SHELVES IN WATER.**
- After cleaning is completed, turn on power to the merchandiser.



CLEANING HONEYCOMB ASSEMBLIES

Honeycombs should be cleaned every six months. Dirty honeycombs will cause merchandisers to perform poorly. The honeycombs may be cleaned with a vacuum cleaner. Soap and water may be used if all water is removed from the honeycomb cells before replacing. Be careful not to damage the honeycombs.

1. Using a flat object such as a screw driver, compress the honeycomb and remove it from its retainer.
2. Clean and dry the honeycomb.
3. After cleaning, replace in reverse order.

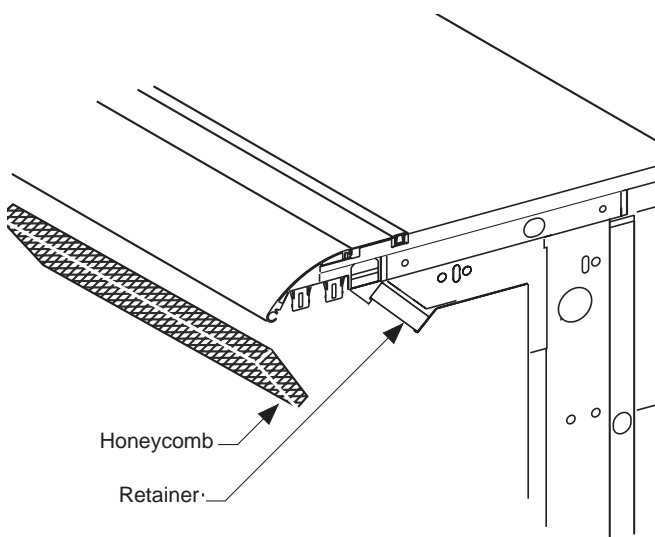

Multi-deck Honeycomb Replacement

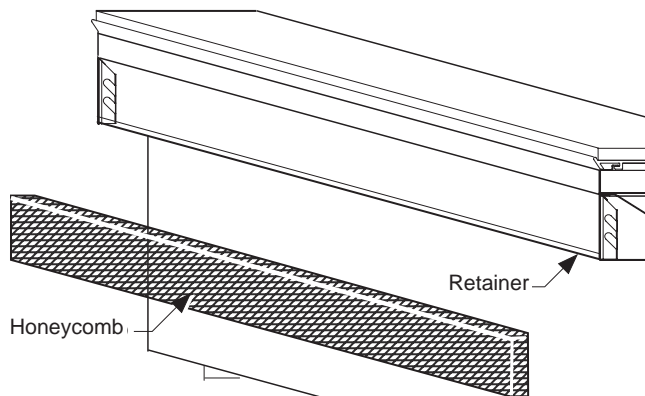

Single Deck Honeycomb Replacement

REMOVING INTERIOR BACK PANELS

The interior back panels may be removed for cleaning and to gain access to the evaporator coils. Remove the rear interior back panels as follows:

1. **DISCONNECT THE ELECTRICAL POWER TO THE MERCHANDISER.**
2. Remove shelving.
3. Remove the lower panel first: lift the panel up, then pull forward and out.
4. Remove the top panel.
5. Replace panels in reverse order, starting with the top panel.
6. After cleaning or servicing the merchandiser, reconnect the electrical power.

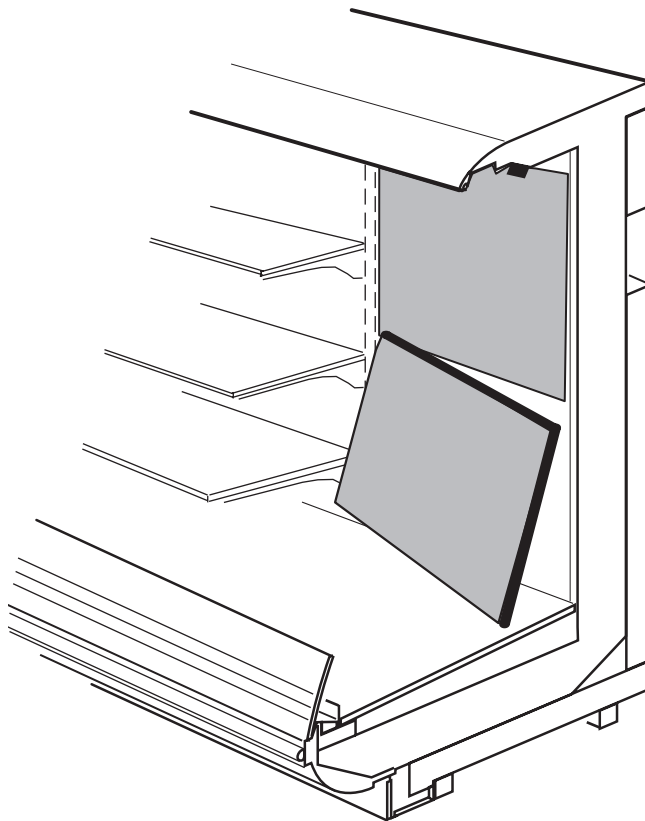

CLEANING COILS

NEVER USE SHARP OBJECTS AROUND COILS. Use a soft brush or vacuum brush to clean debris from coils. Do not puncture coils!

Do not bend fins. Contact an authorized service technician if a coil is punctured, cracked, or otherwise damaged.

ICE in or on the coil indicates the refrigeration and defrost cycle is not operating properly. Contact an authorized service technician to determine the cause of icing and to make adjustments as necessary. To maintain product integrity, move all product to a cooler until the unit has returned to normal operating temperatures.

CLEANING BUMPERS

Clean bumpers with household spray cleaner.

To remove marks from a ballpoint pen, use hair spray or dry erase cleaner.

REMOVING SCRATCHES FROM BUMPER

Most scratches and dings can be removed using the following procedure.

1. Use steel wool to smooth out the surface area of the bumper or top rail.
2. Clean area.
3. Apply vinyl or car wax and polish surface for a smooth glossy finish.

CLEANING UNDER MERCHANDISERS

Remove lower front panels. Use a vacuum with a long wand attachment to remove accumulated dust and debris from under the merchandiser.

CLEANING PREP TOP

Prep areas and bins must be kept clean at all times. Bins and lids lift out for thorough washing. Use paper towels to remove debris that may have fallen below the pans. Do not put water into the area below food bins.

Always follow NSF guidelines and local code.

5-4 MAINTENANCE

CLEANING STAINLESS STEEL SURFACES

Use non-abrasive cleaning materials, and always polish with grain of the steel. Use warm water or add a mild detergent to the water and apply with a cloth. Always wipe rails dry after wetting.

Use alkaline chlorinated or non-chlorine containing cleaners such as window cleaners and mild detergents. Do not use cleaners containing salts as this may cause pitting and rusting of the stainless steel finish. Do not use bleach.

Clean frequently to avoid build-up of hard, stubborn stains. A stainless steel cleaning solution may be used periodically to minimize scratching and remove stains.

Rinse and wipe dry immediately after cleaning. Never use hydrochloric acid (muriatic acid) on stainless steel.



MAINTAINING FLUORESCENT LAMPS

Fluorescent lamps should not be allowed to run to failure. If a re-lamp schedule is not in place, the tubes should be inspected for signs of degradation (blackened ends). Degraded or failed tubes should be replaced.

Allowing severely degraded lamps to operate may cause a ballast failure or could expose the lamp holder to excessive heat. Replacing degraded bulbs is more cost effective than replacing ballast and lamp-holders.

Traditional re-lamp programs are 18- to 24-month intervals. In the absence of a re-lamp program, a yearly inspection of the lightning system is recommended.

1. Inspect all lamp sockets and plug-receptacle connections for signs of arcing. Replace any component that shows signs of arcing.
2. Make sure all unused receptacles have their close-off covers securely installed.
3. Make sure proper cleaning procedures are followed. Lights and fans **MUST** be turned off when a case is cleaned and **MUST** be allowed to dry before turning power back on.
4. Do not use a pressure nozzle to clean inside a case.

SERVICE

REPLACING FAN MOTORS AND BLADES

See cross section for location of evaporator fans. Should it ever be necessary to service or replace the fan motors or blades be certain that the fan blades are re-installed correctly. **THE BLADES MUST BE INSTALLED WITH RAISED EMBOSSED (PART NUMBER ON PLASTIC BLADES) POSITIONED AS INDICATED ON THE PARTS LIST.** (Refer to the case data sheet for each model.)

For access to these fans:

1. Turn off power.
2. Remove bottom display pans.
3. **Disconnect fan from wiring harness.**
4. Remove fan blade.
5. Lift fan plenum and remove screws holding bottom of motor to fan basket.
6. Replace fan motor and blade.
7. Lower fan plenum.
8. Reconnect fan to wiring harness.
9. Turn on power.
10. Verify that motor is working and blade is turning in the correct direction.
11. Close air gaps under fan plenum. Warmer air moving into refrigerated air reduces effective cooling. If the plenum does not rest against the case bottom without gaps, apply foam tape to the bottom of the fan plenum to reduce improper air movement. Use silicone sealant to close other gaps.
12. Replace display pans. Bring merchandiser to operating temperature before restocking.

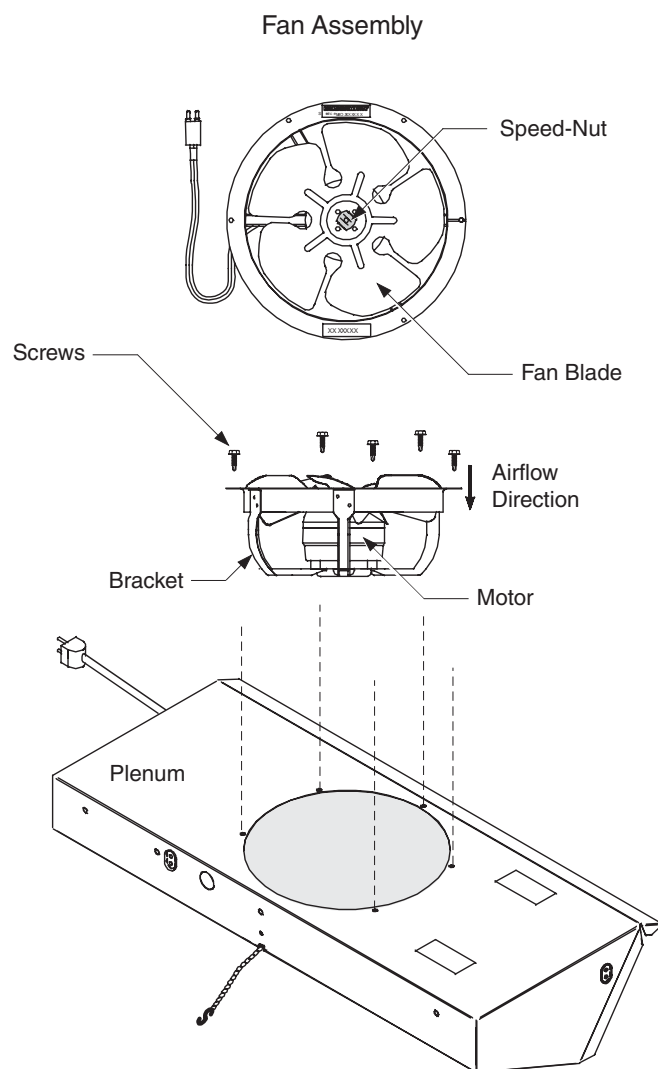

REPLACING LED CANOPY LIGHT BARS

There are always two rows of canopy LED lights. The rear light bar illuminates the upper section of the case and the front light bar illuminates the lower section of the case. The front and rear light bars are labeled **FRONT** and **REAR** respectively and have a different shaped lens. They shall not be interchanged.

Front Canopy LED Light Bar

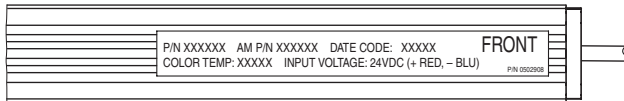

Rear Canopy LED Light Bar

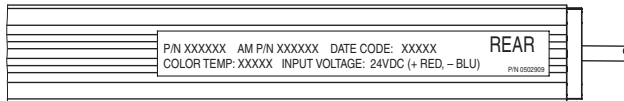

The light bars are attached to the lamp panel using clips. When replacing clips ensure that the part number of the clip is the same as the original clip. The clips are color coded to simplify identification of the proper clip to be used.

The light bars are connected through a two-conductor connector. Push on the release tab on the connector, then pull down on the connector. Do not pull on wires. LED power source is 24-volts for safety.

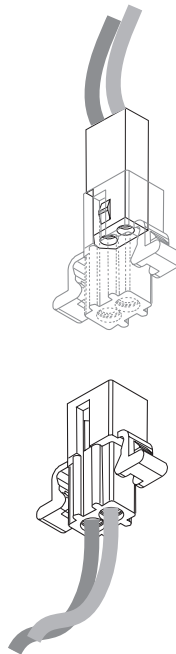

Canopy LED Light Connector

REPLACING LED SHELF LIGHT BARS

The LED shelf light bars are held in place using a magnetic surface on the back of the light bar.

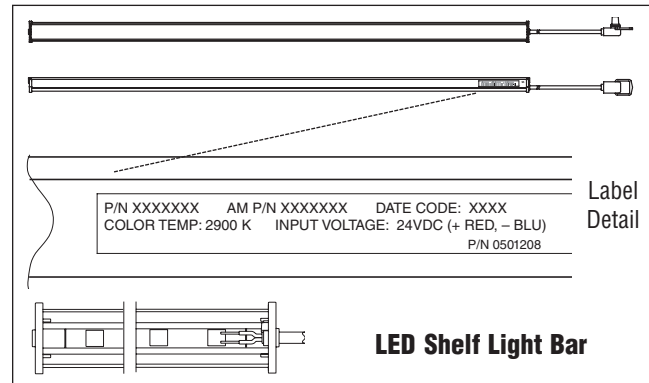

1. Turn off power to the merchandiser, and turn canopy light switch off. Unplug the shelf connector from its socket.

2. Replace with the appropriate Hussmann LED light bar.

REPLACING LED POWER SUPPLIES

The LED power supplies for canopy lights and shelf lights are located at the top of the merchandiser inside the canopy.

1. **DISCONNECT POWER TO THE MERCHANDISER.**

2. Remove light bars from the canopy.

3. Remove the screws that secure the lamp panel.

4. Grasp the lamp panel at its front edge and carefully pull down. It will swing freely from its hinged rear edge.

5. Replace power supply and reassemble parts in reverse order.

6. Reconnect the electrical power.

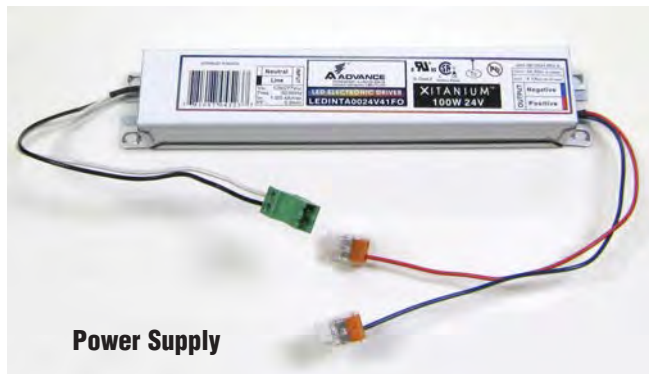

Power Supply

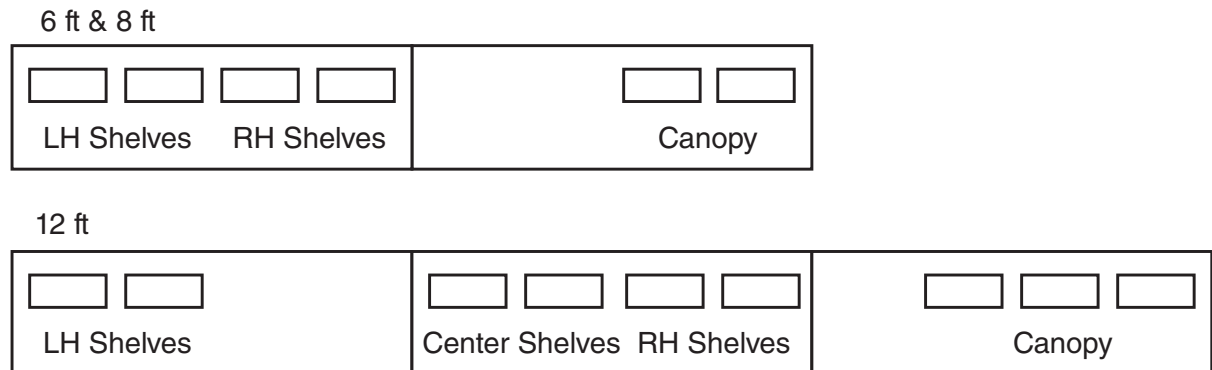

Canopy and Shelf LED Power Supply Arrangement

REPLACING FLUORESCENT LAMPS

Fluorescent lamps are furnished with moisture resistant lamp holders, shields and end caps. Whenever a fluorescent lamp is replaced, be certain to reinstall the lamp shields and end caps.

The switch in the canopy operates both the canopy and the shelf lamps. The rail lamp switch is located on the rail.

Inspect all lamp sockets and plug-receptacle connections for signs of arcing. Replace any component that shows signs of arcing.

Make sure all unused receptacles have their close-off covers securely attached.

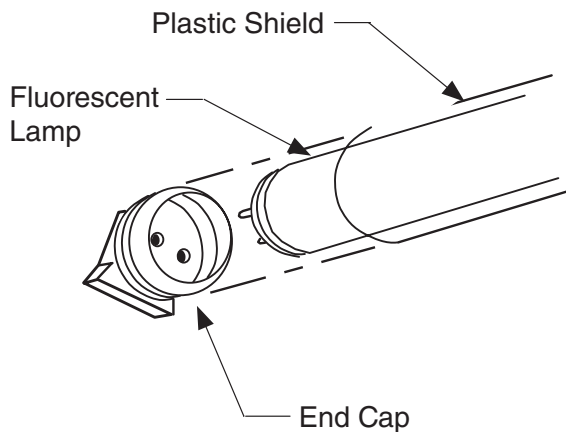

Fluorescent Lamp Disposal: The United States Environmental Protection Agency has information regarding environmentally-safe fluorescent lamp waste management programs. On the Net: EPA Web site: <http://www.epa.gov/osw/hazard/wastetypes/universal/lamps/recycle.htm>

IMPORTANT!

Always replace lamp holders and end caps with Hussmann lamp holders and end caps.

Use of non-Hussmann parts may result in poor electrical contact and short lamp life.

REPLACING LAMP HOLDERS AND END CAPS

The Impact lamp holder is designed to snap into the sheet metal of the case. The lamp holder has a locking 'nub' which fits inside the groove of specially designed end caps.

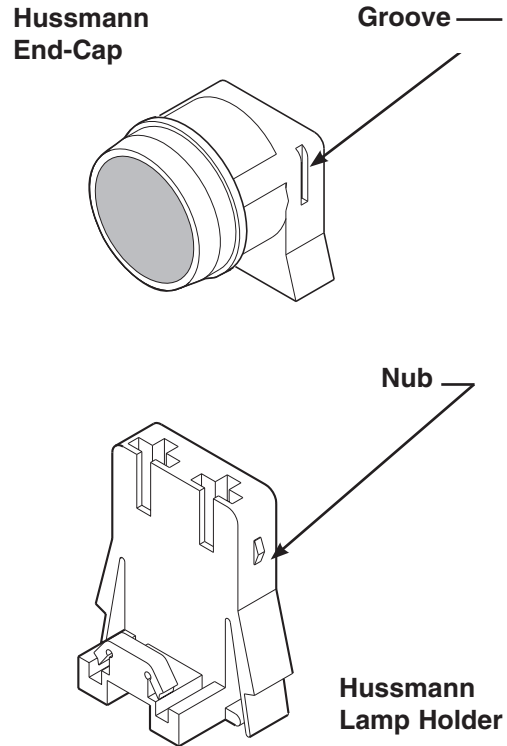

CAUTION

Fluorescent lamps contain mercury vapor. Mercury exposure at high levels can harm the brain, heart, kidneys, lungs, and immune system of people of all ages. Do not break or puncture fluorescent lamps. Dispose of, or store, all fluorescent lamps in accordance with Federal (40 CFR 273), State, and local hazardous waste requirements. Refer to <http://www.epa.gov/mercury/about.htm>

REPLACING ELECTRONIC BALLASTS

Rail Lamp Ballast

The rail lamp ballast is located in the wireway, behind the lower front panel at the left-hand end of the merchandiser. **NOTE:** The switch for the rail lamp is separate from the canopy and shelf lighting. The rail lamp switch is located on the rail.

To gain access:

1. **DISCONNECT THE ELECTRICAL POWER TO THE MERCHANDISER.**
2. Remove the lower front panel by lifting it up and out.
3. Remove screws attaching the wireway cover, then remove cover.
4. Service or replace ballast as required. Reassemble items as they were originally installed.
5. Reconnect the electrical power.

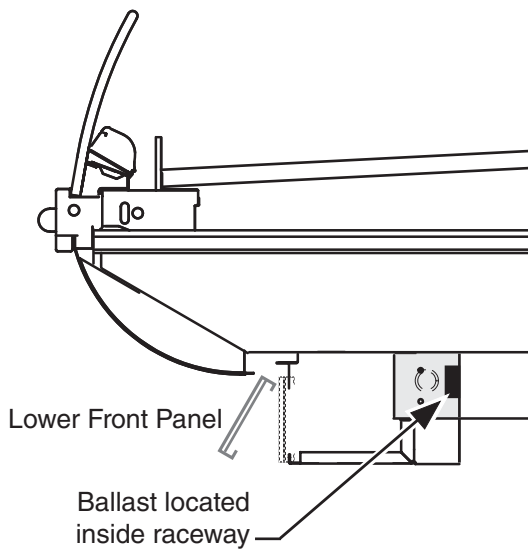

Canopy and Shelf Lamp Ballasts

These ballast are located at the top of the merchandiser inside the canopy. The switch in the canopy operates both the canopy and the shelf lamps. The rail lamp has a separate switch.

1. **DISCONNECT POWER TO THE MERCHANDISER.**
2. Remove 'tee' molding on top of canopy.
3. Remove screws that secure the access panel, then remove the panel.
4. Replace ballast and reassemble parts in reverse order.
5. Reconnect the electrical power.

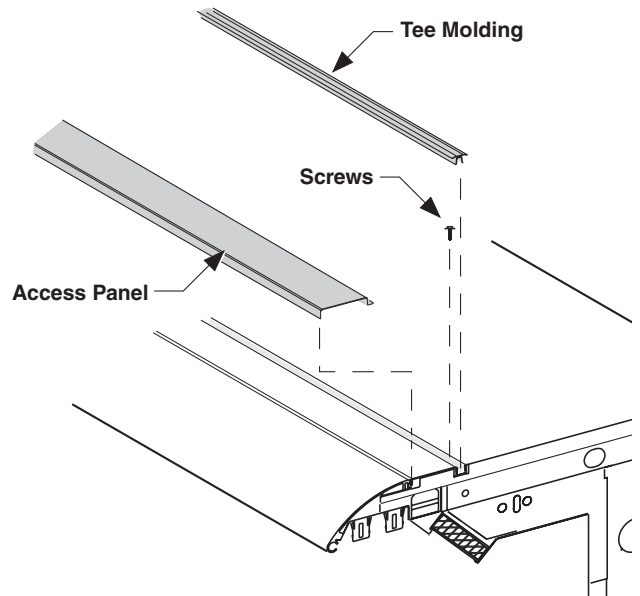

NOTE:
 The ballast are in sequence from the left-hand end of the merchandiser (facing front) as follows: Farthest left, bottom shelf ballast, then center shelf or shelves, top shelf, first row canopy, and last is second row canopy.
 The rail lamp ballast is located in the wireway.

Prep Case Ballast

The prep case ballast is located in the wireway, behind the lower back panel at the left-hand end of the merchandiser.

To gain access:

1. **DISCONNECT THE ELECTRICAL POWER TO THE MERCHANDISER.**
2. Remove screws that secure the access panel, then remove the panel.
3. Remove screws attaching the wireway cover, then remove cover.
4. Service or replace ballast as required. Reassemble items as they were originally installed.
5. Reconnect the electrical power.



Ballast Located
Behind This Panel

REPLACING DAMAGED DRAIN FITTING

The following procedure is for the field repair of a broken drain fitting.

1. Use a drill with a 2 in. (51 mm) hole saw to drill out the bottom of the drain fitting. Be sure to drill completely through fitting and bottom liner.

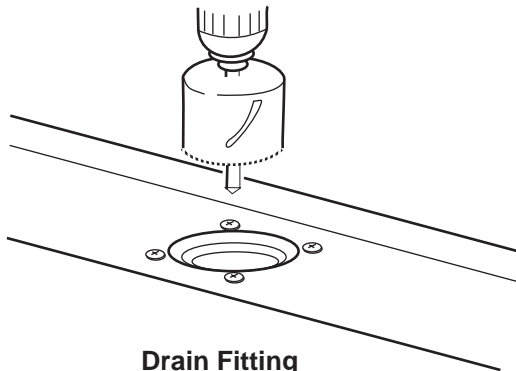

**Drain Fitting
Viewed from Inside Merchandiser**

2. Insert coupling into drain fitting. **Do not apply PVC or ABS pipe sealer to drain fitting, or the drain fitting may become damaged or crack — Hand tighten.**
3. Install a PVC adapter on the drip trap. Apply primer-sealer to a stub piece of PVC pipe and insert between coupling and adapter.

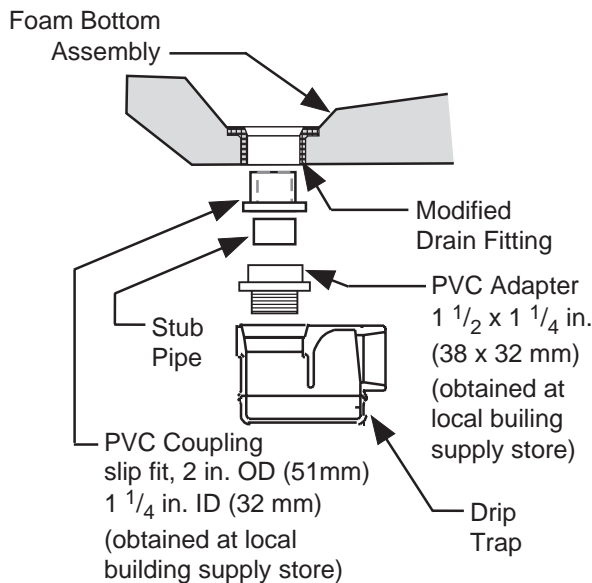

REPAIRING ALUMINUM COIL

The aluminum coils used in Hussmann merchandisers may be easily repaired in the field. Materials are available from local refrigeration wholesalers.

Hussmann recommends the following solders and technique:

Solders

Aladdin Welding Products Inc.
P.O. Box 7188
1300 Burton St.
Grand Rapids, MI 49507

Phone: 1-800-645-3413
Fax: 1-800-645-3414

X-Ergon
1570 E. Northgate
P.O. Box 2102
Irving, TX 75062

Phone: 1-800-527-9916

NOTE:

Hussmann Aluminum melts at 1125°F (607°C)

Aladdin 3-in-1 rod at 732°F (389°C)

X-Ergon Acid core at 455°F (235°C)

REPAIRING ALUMINUM COIL

The aluminum coils used in Hussmann merchandisers may be easily repaired in the field. Materials are available from local refrigeration wholesalers.

Hussmann recommends the following solders and technique:

Solders

Aladdin Welding Products Inc.

1300 Burton St., P.O. Box 7188

Grand Rapids, MI 49507

Phone: 1-800-645-3413

Fax: 1-800-645-3414

X-Ergon

1570 E. Northgate, P.O. Box 2102

Irving, TX 75062

Phone: 1-800-527-9916

NOTE:

Hussmann Aluminum melts at 1125°F (607°C)

Aladdin 3-in-1 rod at 732°F (389°C)

X-Ergon Acid core at 455°F (235°C)



WARNING

REFRIGERANT VAPOR IS HAZARDOUS TO YOUR HEALTH AND CAN CAUSE DEATH.

Be sure that any room where you are working is thoroughly ventilated, especially if a leak is suspected.

Avoid breathing refrigerant and lubrication vapor or mist. Exposure may irritate eyes, nose and throat. If accidental system discharge occurs, ventilate work area before resuming service

Refrigeration lines are under pressure and should be depressurized before attempting to make any connections.

Read all safety information regarding the safe handling of refrigerant and refrigerant oil, including the Material Safety Data Sheet. MSDS sheets can be obtained from your refrigerant supplier.

Always wear safety goggles and protective gloves when working with refrigerants. Contact with refrigerant may cause injury. Disconnect hoses with extreme caution! All hoses may contain liquid refrigerant under pressure.

When brazing pipes, be sure to use the insulation blanket shipped with the merchandiser to prevent fire or damage to the plastic case bottom.



HUSSMANN[®]

**To obtain warranty information
or other support, contact your
Hussmann representative.
Please include the model and
serial number of the product.**

Hussmann Corporation, Corporate Headquarters: Bridgeton, Missouri, U.S.A. 63044-2483 01 October 2012

Husmann Corporation

12999 St. Charles Rock Road
Bridgeton, MO 63044-2483
www.husmann.com