

# HUSSMANN®

## ***Ultra Low Front Multi-deck with EcoVision Doors***

Meat, Delicatessen, Dairy and Produce  
Merchandisers



**IMPORTANT**  
**Keep in store for  
future reference!**

MANUAL- I/O LOW FRONT MEDIUM TEMP ECOVISION

***Installation &  
Operation Manual***  
Shipped with Technical Data Sheets

**P/N 0524109\_H**  
January 2022  
**Spanish 0532248**






# BEFORE YOU BEGIN

Read these instructions completely and carefully.



## ANSI Z535.5 DEFINITIONS

-  • **DANGER** – Indicate[s] a hazardous situation which, if not avoided, will result in death or serious injury.
-  • **WARNING** – Indicate[s] a hazardous situation which, if not avoided, could result in death or serious injury.
-  • **CAUTION** – Indicate[s] a hazardous situation which, if not avoided, could result in minor or moderate injury.
- **NOTICE** – Not related to personal injury – Indicates[s] situations, which if not avoided, could result in damage to equipment.

The information contained in this document is the property of Hussmann Corporation and shall not be used in whole or in part without written permission.

## CAUTION

This manual was written in accordance with originally prescribed equipment that is subject to change. Hussmann reserves the right to change all or part of the equipment for future stores such as, but not limited to, controllers and electrical specifications.

## WARNING

Do not use mechanical devices or other means to accelerate the defrosting process.

Do not use electrical appliances inside the food storage compartments of the case(s).

## WARNING

Case ventilation openings must be clear of any obstructions. Do not damage the refrigerant circuit.

## WARNING

### PERSONAL PROTECTION EQUIPMENT (PPE)

Only qualified personnel should install and service this equipment. Personal Protection Equipment (PPE) is required whenever installing or servicing this equipment. Always wear appropriate PPE as required by OSHA regulations, as well as all other federal, state and local codes. PPE may include, but is not limited to, safety glasses, gloves, protective boots or shoes, long pants, and a long-sleeve shirt. Observe all precautions on tags, stickers, labels and literature attached to this equipment.

## WARNING

**Proper Field Wiring and Grounding Required!**  
Failure to follow code could result in death or serious injury. All field wiring **MUST** be performed by qualified personnel. Improperly installed and grounded field wiring poses **FIRE** and **ELECTROCUTION** hazards. To avoid these hazards, you **MUST** follow requirements for field wiring installation and grounding as described in **NEC** and your local/state electrical codes.

## WARNING

### — LOCK OUT / TAG OUT —

To avoid serious injury or death from electrical shock, always disconnect the electrical power at the main disconnect when servicing or replacing any electrical component. This includes, but is not limited to, such items as controllers, electrical panels, condensers, lights, fans, and heaters.

## WARNING

Case tipping may occur if cases are not properly leveled and secured.

## TABLE OF CONTENTS

INSTALLATION TOOL LIST ..... v

DOOR PARTS IDENTIFICATION ..... vi

### INSTALLATION

NSF Listing .....	1-1
Federal / State regulation .....	1-1
Unloading .....	1-1
Serial Plate Location .....	1-1
Shipping Damage .....	1-2
Exterior Loading .....	1-3
Merchandisers Shipped with End Installed .....	1-3
Shipping Braces .....	1-3
Merchandiser Leveling .....	1-3
Adjusting EcoVision Doors .....	1-6
Adjusting Door Tension .....	1-8
Joining Instructions .....	1-9
Preparation .....	1-9
Apply Gaskets .....	1-9
Align End Frames .....	1-10
Align and Fasten Canopies .....	1-10
Tighten End Frames .....	1-11
Fasten Mullions .....	1-12
Seal Merchandisers .....	1-12
Installing Seismic Restraints .....	1-13
Install Splashguard Brackets .....	1-15
Offsetting Bumper .....	1-15
Installing End Assemblies .....	1-17
Optional Front Rail Light .....	1-23

### REFRIGERATION / ELECTRICAL

Refrigerant .....	2-1
Refrigerant Piping .....	2-1
Connection Location .....	2-1
Multiplexing .....	2-2
Line Sizing .....	2-2
Oil Traps .....	2-2
Pressure Drop .....	2-2
Insulation .....	2-3
Suction Line .....	2-3
Liquid Line .....	2-3
Refrigeration Thermostat .....	2-4
Defrost Termination Thermostat .....	2-4
Defrost Sequences .....	2-4
Merchandiser Electrical Data .....	2-5
Electrical Connections .....	2-5
Field Wiring .....	2-5
Identification of Wiring .....	2-5

### DRIP PIPING AND SPLASHGUARDS

Waste Outlet and Water Seal .....	3-1
Installing Drip Piping .....	3-1
Optional Drip Piping Arrangements .....	3-2
Installing Splashguards .....	3-3

---

IMPORTANT  
KEEP IN STORE FOR FUTURE REFERENCE

*Quality that sets industry standards!*

**HUSSMANN®**

12999 St. Charles Rock Road • Bridgeton, MO 63044-2483

U.S. & Canada 1-800-922-1919 • Mexico 01-800-890-2900

[www.hussmann.com](http://www.hussmann.com)

© 2022

Hussmann Corporation

**START UP / OPERATION**

Start up . . . . . 4-1  
Load Limits . . . . . 4-1  
Stocking . . . . . 4-1  
Door Hold Open . . . . . 4-2  
Multi-deck Shelf Alignment . . . . . 4-2  
Multi-deck Shelf Configuration . . . . . 4-3  
Shelf Maximum Weight Limits . . . . . 4-4  
Installing  
    FDA/NSF Required Thermometer . . . . . 4-4

**MAINTENANCE**

Care and Cleaning . . . . . 5-1  
    Fan Plenum . . . . . 5-1  
    Removable Return Air Grille . . . . . 5-1  
    Fascia Panels . . . . . 5-1  
    Exterior Surfaces . . . . . 5-2  
    Interior Surfaces . . . . . 5-2  
Cleaning Honeycomb Assemblies . . . . . 5-3  
Cleaning EcoVison II Doors . . . . . 5-3  
Cleaning Mirrors . . . . . 5-3  
Cleaning Coils . . . . . 5-4  
Removing Interior Back Panels . . . . . 5-4  
Cleaning Stainless Steel Front Rails . . . . . 5-5  
Removing Scratches from Bumper . . . . . 5-5  
Cleaning Under Merchandisers . . . . . 5-5  
Maintaining Fluorescent Lamps . . . . . 5-5

**SERVICE**

Replacing Fan Motors and Blades . . . . . 6-1  
Replacing LED Canopy Fixtures . . . . . 6-2  
Replacing LED Vertical Mullion  
    Fixtures . . . . . 6-2  
Replacing LED Power Supplies . . . . . 6-3  
Repairing Aluminum Coil . . . . . 6-4

**WARRANTY**

### EXCEL INSTALLATION TOOL LIST

\*\*\*\*\*



#### REVISION HISTORY

#### Unloading From Trailer:

##### REVISION H

- 1. Added Coil Cleaning note, Page 5-4

Lever Bar (also known as a Mule,  
Johnson Bar, J-bar, Lever Dolly, and pry lever)  
Moving Dolly

##### REVISION G

- 1. Updated Door Parts List, Page iv
- 2. Added Seismic Kit, Page 1-19, 1-20
- 3. Updated LEDs, Pages 6-2, 6-3



##### REVISION F

- 1. Updated California Warning

#### Setting Case Line-Up:

##### REVISION E

- 1. Removed Door Parts List

Level, 4 ft suggested

##### REVISION D

- 1. Added California Prop 65 Warning
- 2. Added Drain Warning Page, 3-3
- 3. Added Adjusting EcoVision Doors, Page 1-7

Ratchet

1/4 in. Socket

##### REVISION C

- 1. Added Door Parts Identification, Page vi
- 2. Revised Adjusting Door Tension, Page 1-5.
- 3. Door Hold Open Page 4-2
- 4. Added Maintaining  
Fluorescent Lamps, Page 5-5
- 5. Added Door Parts Lists Page 6-7, 6-8

5/16 in. Socket

1/2 in. Socket

1/2 in. Open End Wrench

Battery Drill/Screw Gun

Caulking Gun

10 in. Adjustable Crescent Wrench

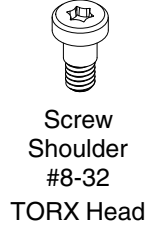
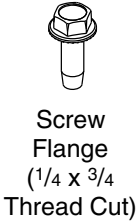
##### REVISION B

- 1. Removed Replacement Parts List, Page vi and vii
- 2. Updated Illustration, Page 1-8

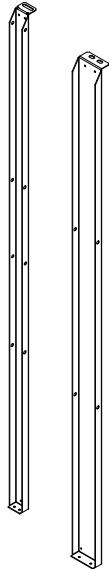
##### REVISION A

- 1. Original issue.

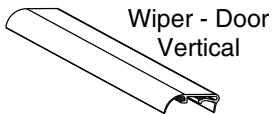
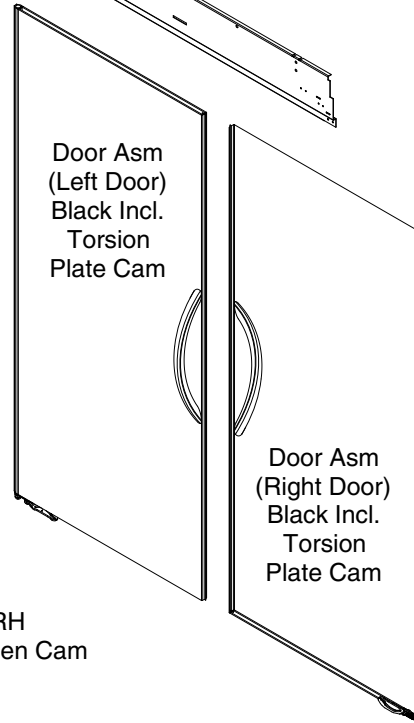
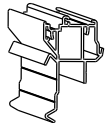
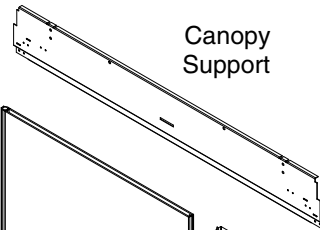
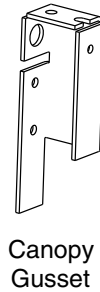
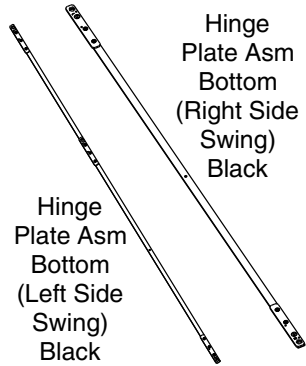
# Door Parts Identification



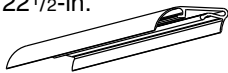
Mullion  
End - Black



Mullion  
Center - Black



Wiper - Horizontal  
Mullion 22 1/2-in.



Door Retainer - Plastic - 44-7/8 in.

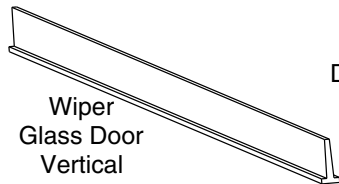
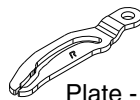


Plate - LH  
Door Hold Open Cam



Plate - RH  
Door Hold Open Cam



## EcoVision II Door Parts Identification

## INSTALLATION

### NSF CERTIFICATION

These merchandisers are manufactured to meet ANSI / UL 471 standard requirements for safety. Proper installation is required to maintain this listing. Near the serial plate, each case carries a label identifying the type of conditions for which the merchandiser was tested.

**ANSI/NSF-7 Type I – Display Refrigerator / Freezer Intended for 75°F / 55%RH Ambient Application**

**ANSI/NSF-7 Type II – Display Refrigerator / Freezer Intended for 80°F / 55%RH Ambient Application**

**ANSI/NSF-7 – Display Refrigerator Intended for Bulk Produce**

### FEDERAL / STATE REGULATION

These merchandisers, at the time they are manufactured, meet all federal and state / provincial regulations.

Excel merchandisers have internal frames. A 3 inch (76 mm) space between the rear of the merchandiser and wall must be maintained for air circulation. However, in high ambient conditions, sweating may still occur. If this happens install a method of forced ventilation such as a fan ventilation kit.

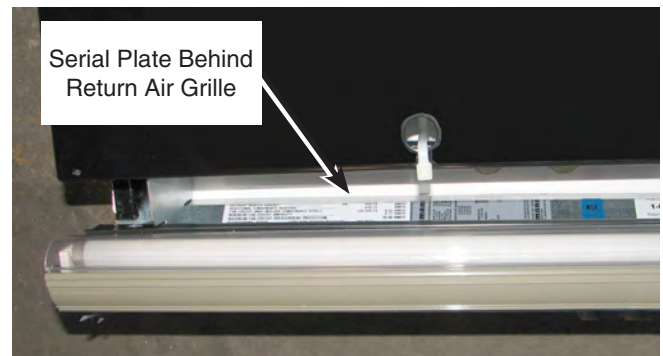
### UNLOADING

Improper handling may cause damage to the merchandiser when unloading. To avoid damage:

1. Do not drag the merchandiser out of the trailer. Use a Johnson bar (mule).
2. Use one dolly to remove the merchandiser from the trailer.
3. Use two dollies to move merchandisers to lineup.

### SERIAL PLATE LOCATION

Direct a flashlight through the return air grille behind the front rail to locate the serial plate on the left end of the ultra-low front model.



## SHIPPING DAMAGE

All equipment should be thoroughly examined for shipping damage before and during unloading.

This equipment has been carefully inspected at our factory. Any claim for loss or damage must be made to the carrier. The carrier will provide any necessary inspection reports and/or claim forms.

### Apparent Loss or Damage

If there is an obvious loss or damage, it must be noted on the freight bill or express receipt and signed by the carrier's agent; otherwise, carrier may refuse claim.

### Concealed Loss or Damage

When loss or damage is not apparent until after equipment is uncrated, retain all packing materials and submit a written request to the carrier for inspection, within 15 days.

Excel merchandisers have internal frames. A 3 inch (76 mm) space between the rear of the merchandiser and wall must be maintained for air circulation. However, in high ambient conditions, sweating may still occur. If this happens install a method of forced ventilation such as a fan ventilation kit.



This warning does not mean that Hussmann products will cause cancer or reproductive harm, or is in violation of any product-safety standards or requirements. As clarified by the California State government, Proposition 65 can be considered more of a 'right to know' law than a pure product safety law. When used as designed, Hussmann believes that our products are not harmful. We provide the Proposition 65 warning to stay in compliance with California State law. It is your responsibility to provide accurate Proposition 65 warning labels to your customers when necessary. For more information on Proposition 65, please visit the California State government website.

**! WARNING**

**Do NOT stand or walk on top of merchandiser. Do not store items or flammable materials atop the unit.**

**! WARNING**

**Do NOT remove shipping braces until the merchandisers are positioned for installation.**

## EXTERIOR LOADING

**Do NOT walk on top of merchandisers** or damage to the merchandisers and serious personal injury could occur. **THEY ARE NOT STRUCTURALLY DESIGNED TO SUPPORT EXCESSIVE EXTERNAL LOADING** such as the weight of a person. Do not place heavy objects on the merchandiser.

## MERCHANDISERS SHIPPED WITH END INSTALLED

If the merchandiser was shipped with the end installed, two long bolts were used to hold the shipping brace to the end. If the shipping bolts are reinserted after removing the brace, they will extend into the product area. **THEREFORE, BE SURE TO REPLACE THESE BOLTS WITH THE SHORTER BOLTS PROVIDED.** NSF requires any bolt or screw in the product area be capped or cut off if it has more than three exposed threads.

**NOTE:**

Be careful not to damage the factory installed end while moving the merchandiser. Make sure that tools are positioned past the end and beneath the merchandiser's support bar.

## SHIPPING BRACES

Move the merchandiser as close as possible to its permanent location, then remove all packaging. Check for damage before discarding packaging. Remove all separately packed accessories such as kits and shelves.

Do not remove end braces until joining begins. Recycle braces and hardware.

## MERCHANDISER LEVELING

Merchandisers must be installed level to ensure proper operation of the refrigeration system and to ensure proper drainage of defrost water. During all steps of setting, joining and leveling merchandisers, close attention to position and operation must be maintained.

**NOTE: BEGIN LINEUP LEVELING FROM THE HIGHEST POINT OF THE STORE FLOOR.**

### Preparation

1. Using store blueprints, measure off and mark on floor the exact dimensions/locations of the merchandiser footprint. **A 3 inch space is required behind each merchandiser to prevent condensation.**
2. Snap a chalk line for the front and rear positions of the base legs.
3. Mark the location of each joint from front to back lines.
4. **FLOORS ARE NOT LEVEL!!!** When working with two or more merchandisers to be joined, the whole lineup must be leveled on the same plane, left to right and front to back. This means that the entire lineup must be brought up to the level of the highest case in the lineup.

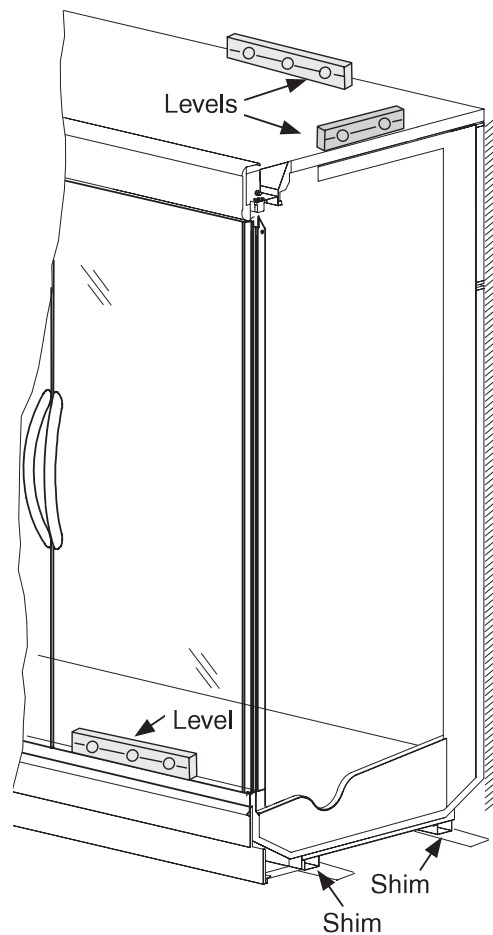
Along the lines previously marked, find the highest point of the floor by:

- Walking the floor and noticing any dips or mounds;
- Using a string level; and
- Using a transit.

### Leveling

Position the first merchandiser at the highest point on the floor. Work outward from that point to create the merchandiser lineup. Use a 48 inch (1220 mm) or longer level for end-to-end leveling. The rear edge of the top foam panel of the merchandiser is a good location for the level at the rear of the case, and the top rail is a good location for the level at the front of the merchandiser. For leveling the merchandiser front-to-rear, a 24 inch (610 mm) level should be placed on the lower flange of the merchandiser end frame. If the merchandiser has a factory installed end, the level should be placed on the canopy support brackets on top of the merchandiser. Suggested level locations are shown in the following illustration.

Level the merchandiser by all four corners. Start at the rear by placing as needed the provided shims under each end of the rear base rail. The shims are long enough to allow the adjoining merchandiser to be leveled with the same shim.

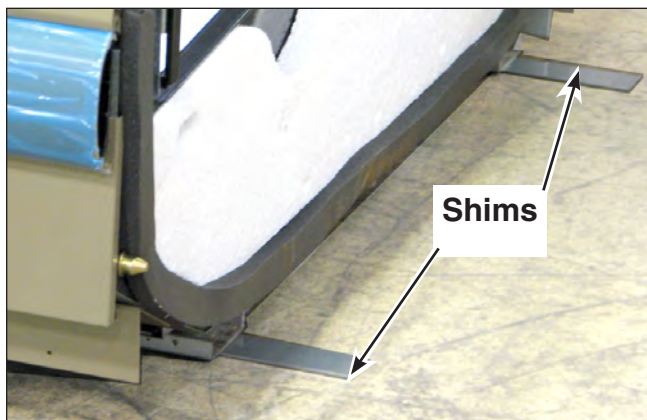


**NOTE:** Do not place levels on Display Pans or on Shelves.

When the rear of the merchandiser is level end-to-end, move to the front of the merchandiser. Use shims at each front corner so that the front is also level from end-to-end. At this point, check to see if the merchandiser is level front-to-rear. If it is not, add shims until the merchandiser is level front-to-rear.

Merchandisers with optional front rail light must have end caps installed. See Page 1-16 for details.

Merchandisers must be level to ensure proper opening and closing speed of the doors.



The merchandiser should be solidly supported at least every 4 feet (1220 mm). Once the merchandiser is level, if any gaps are present under the rails, shims should be inserted under the in line with the center supports.

It is the installing contractor's responsibility to ensure the merchandiser has adequate support under each cross-member. Leveling and supporting are critical to prevent air and water leaks.

**ADJUSTING ECOVISION II DOORS**

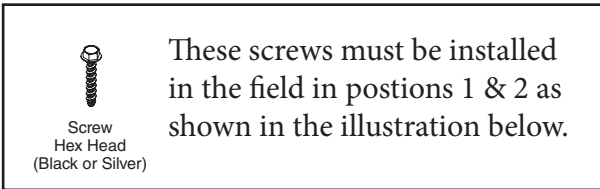
A. Leveling — Merchandisers must be installed level to ensure proper operation of the refrigeration system, and to ensure proper drainage of defrost water.

Glass alignment is also affected with improper leveling of the merchandisers. All steps of setting, joining and case leveling attention to the glass position is critical. Do not attempt to make glass adjustments prior to case leveling.

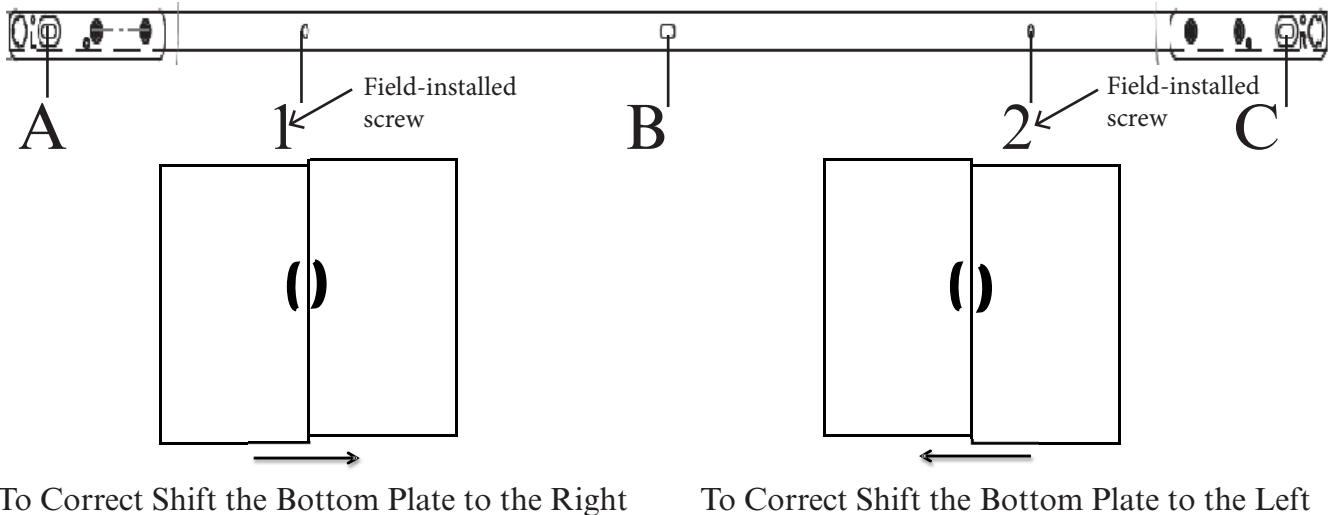
B. Door Adjustment — Loosen the screws A, B and C as shown below (Do not remove the screws completely).

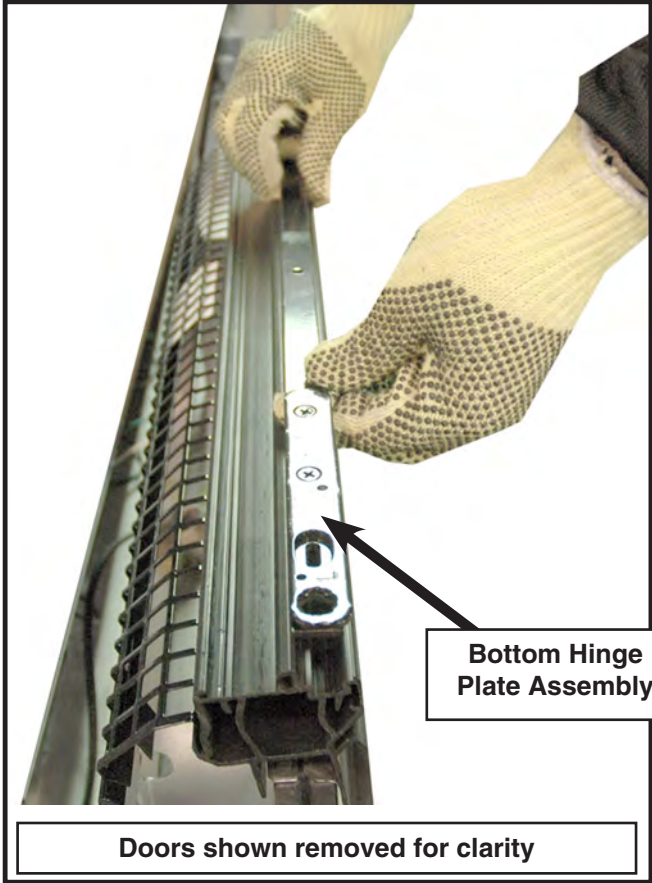
C. Slide the bottom plate left and right until proper alignment is achieved. Retighten the screws A, B and C, and secure screws 1 & 2 into their respective holes. Screws 1 & 2 are located in the installation pack out kit.

The bottom hinge plate can be modulated to assist in door alignment. Location of the bottom hinge plate is shown on following page.



**EcoVision II Door Alignment - Modular Bottom Hinge Plate**





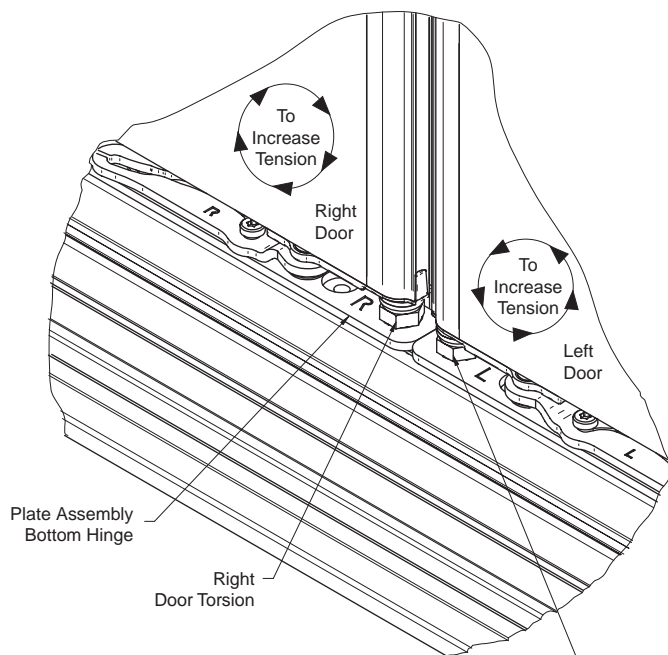
## 1-8 INSTALLATION

### ADJUSTING DOOR TENSION

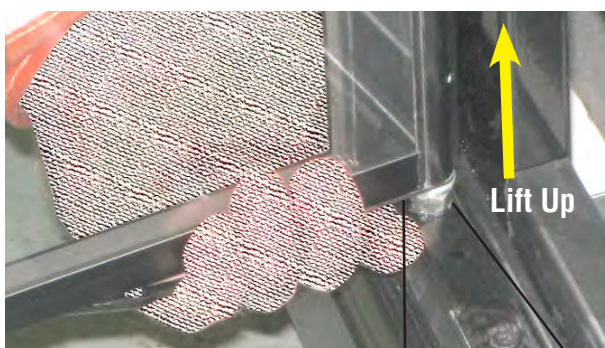
**1.** Check that each EcoVision II door opens and closes properly. The door's closing speed may be adjusted by rotating the adjustable tension rods near the hinge of each door.

**2.** Use a ½ inch wrench to adjust torsion rod. To increase tension, turn wrench toward the door handle until torsion rod seats in bottom hinge plate assembly. An audible “click” is heard while adjusting. Generally, the torsion rod should be adjusted to 4 or 5 clicks. The maximum amount of clicks is 6. Do not over-torque. See next step if the wrench can not be put on the torsion rod because of interference with the contour / rectangular end.

**3.** Do not over-torque the hinge spring assembly. Lift door up and out of bottom hinge plate to remove door tension. Do not use wrench to decrease door tension as this may damage the star pattern on the bottom hinge plate assembly.



Rod Assembly LH Door Torsion  
Turn towards door 1 “click” or 1 turn to lock torsion into next set of teeth. Make sure torsion rod is seated into bottom hinge plate.



(Not Properly Engaged in Hinge Plate)

Door must be properly seated inside bottom hinge plate after door tension is applied.

## JOINING INSTRUCTIONS

Sectional construction means that two or more merchandisers may be joined in line yielding one long continuous display requiring one pair of ends.

ALL JOINTS MUST BE AIR-TIGHT TO PREVENT FORMATION OF ICE OR CONDENSATION.

### Prep Merchandiser

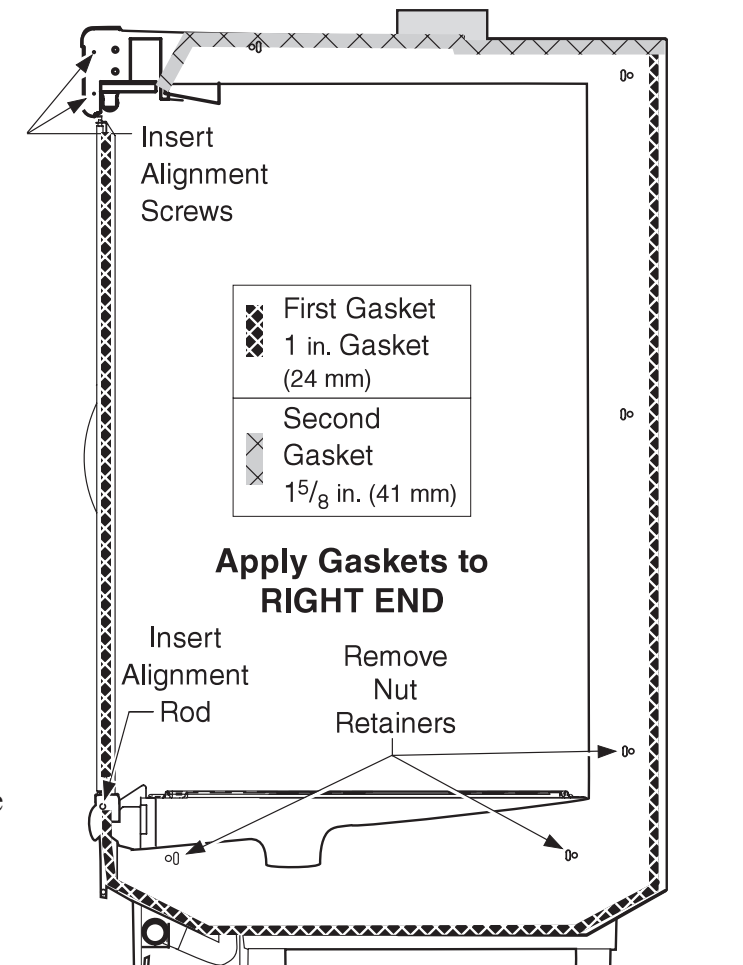
1. Check to be sure that merchandisers are level and that the factory-installed nut retainers are in place. Locate the Joining Kit and check contents.
2. Remove shelves (if installed), display racks, pans and front air grilles from the right end.
3. Remove the lower back interior panel(s) from the right end. To remove a panel, lift it up from its bottom edge and out. No tools are required.

### Apply Gaskets as Follows:

#### Right End

1. Apply the 1 inch (25 mm) gasket around the perimeter of the merchandiser as shown. It must be at the edge. Check to be sure that there are no gaps between gasket and merchandiser.
2. Apply the 1<sup>5</sup>/<sub>8</sub> in. (41 mm) gasket so that one edge is on the metal merchandiser frame and the parallel edge laps the 1 inch gasket. Check to be sure that there are no gaps between merchandiser and gaskets.

A continuous bead of silicone sealant/ caulk may be used in addition to gaskets on mating surfaces but must not be used in lieu of gaskets.



### IMPORTANT

- Do not stretch gasket, especially around corners.
- Do not butt gaskets; always overlap them as shown.
- Remove paper backing after gasket has been applied.
- *Perimeter gasket required by NSF.*
- End caps required for rail light.

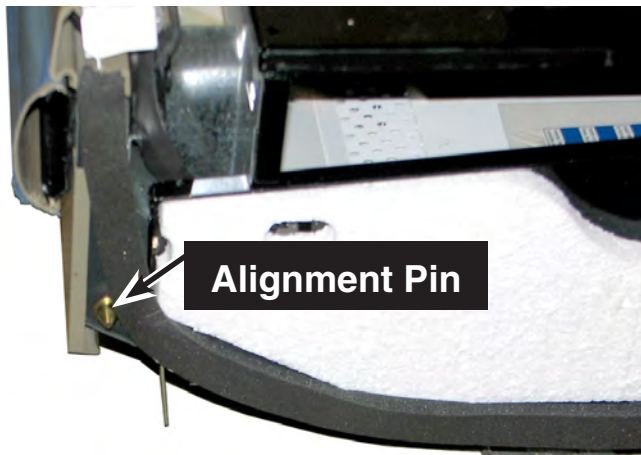
Medium Temperature Ultra Low Front,  
**Excel with EcoVision II Doors**

### Align End Frames

NOTE THAT ALIGNMENT ORDER IS DIFFERENT FROM TIGHTENING ORDER! REFER TO THE ILLUSTRATION.

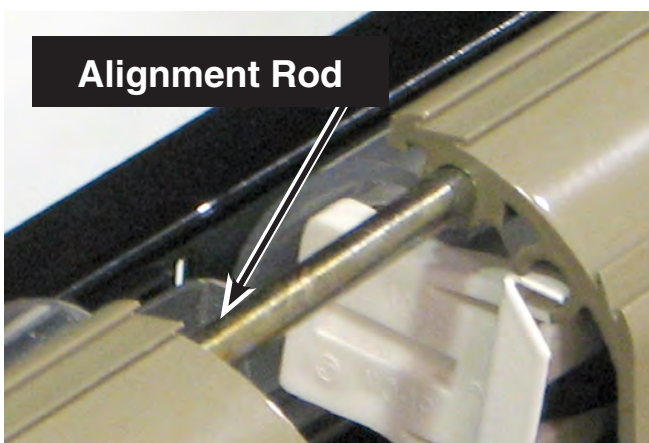
**NOTE: cases must be level before joining.**

1. Insert alignment pin at lower front and lower back.



2. Insert the alignment rod ( $\frac{1}{4}$  in. diameter x 6 in.) through hole in top rail, align and insert into second to rail.

3. *Move the second case as close to the first as possible by pushing or using lever bar (mule).*



4. Match alignment pins with corresponding holes in foam bottom and canopy.

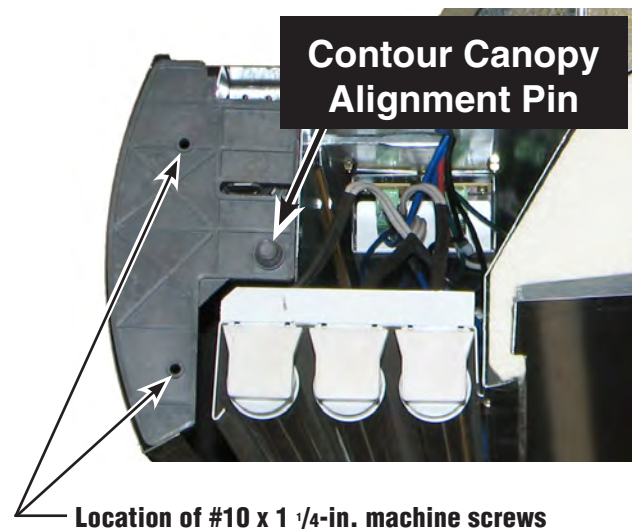
5. In both holes in bottom shoe, place a 2 inch neoprene washer between end frame and metal washer of each merchandiser. Loosely assemble bolt, washers, lockwasher and nut as shown below.

**DO NOT TIGHTEN FULLY.**

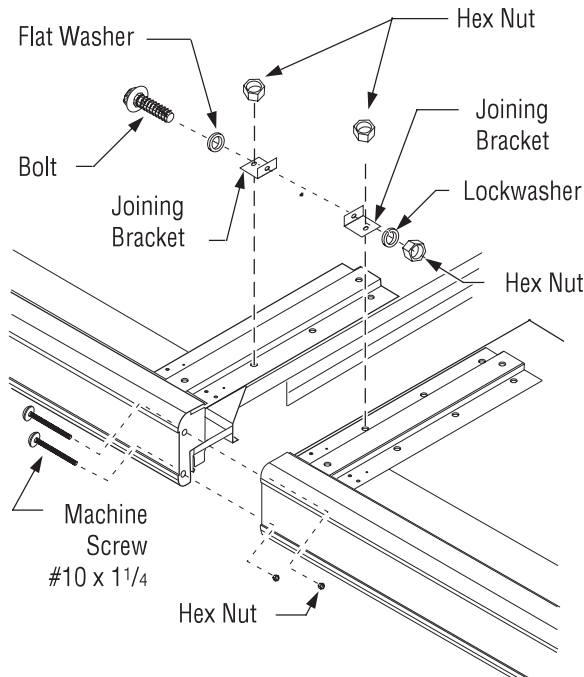
**Do not attempt to draw merchandisers together using nut and bolt.**

### Align and Fasten Canopies

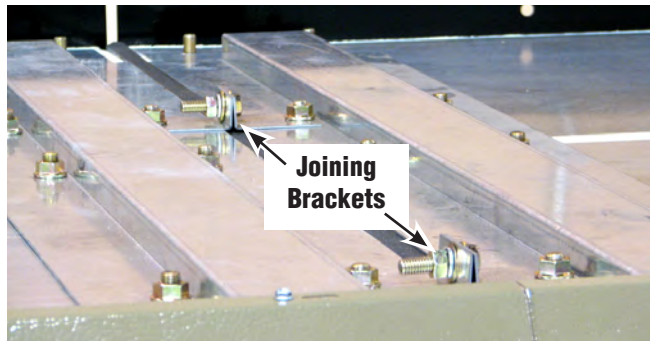
6. Insert a machine screw ( $\#10 \times 1\frac{1}{4}$  in.) through each hole in canopy end cap, align and insert into joining canopy end cap. Fasten with nuts. See detail below. **Do not tighten fully.**



7. Draw canopies of multi-deck wall merchandisers together by using a bolt, flat washers, lockwasher and nut in the joining brackets atop the canopy. See detail below. **Tighten only until canopies touch.**



**Detail for Connecting Canopies of Multi-deck Wall Merchandisers**



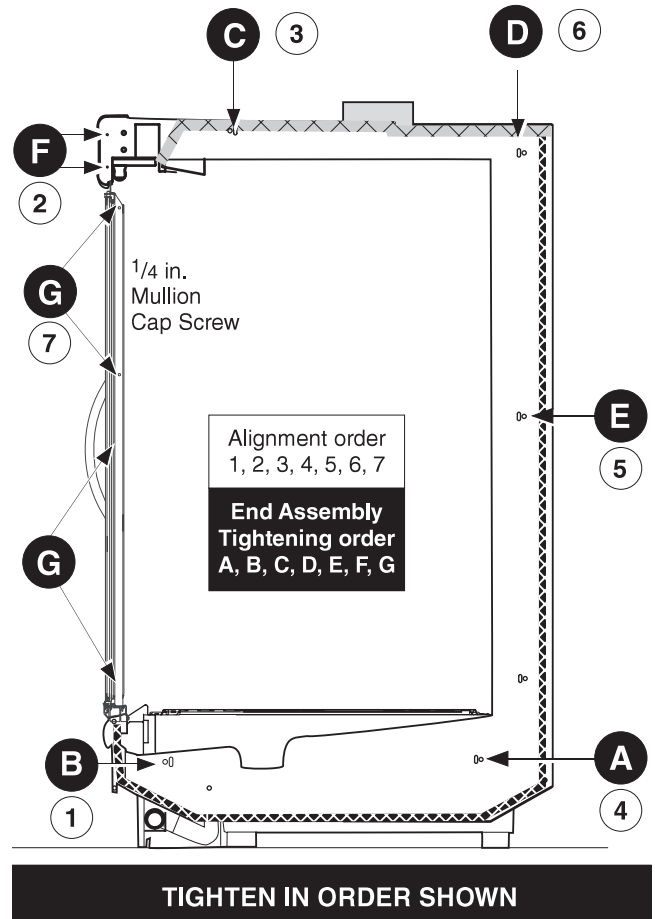
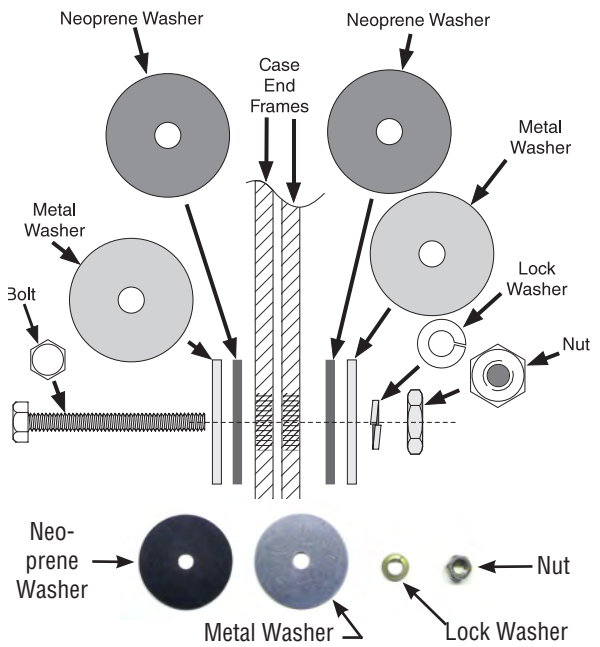
**Detail for Connecting Canopies of Rear Load Ultra Low Front Merchandisers**

**Fasten End Frames**

1. Begin at lower back to draw end frames tight.
2. Tighten joints in the order shown (A, B, C, D, E) until the gaskets are compressed, and merchandisers join smoothly.
3. Tighten screws in canopy end cap ( F ) to complete smooth fit.

**Tighten End Frames**

1. Begin at lower back to draw end frames.



2. Tighten joints following the diagrams until gaskets are compressed, and merchandisers join smoothly.

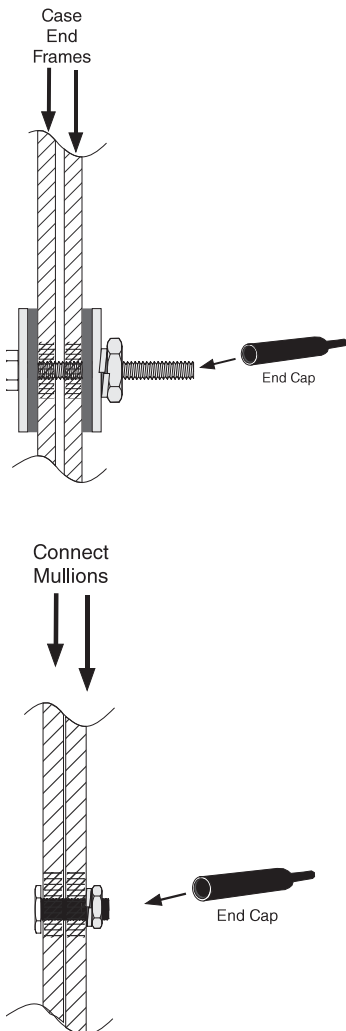
3. Tighten screws in canopy to complete smooth fit.

4. Place plastic end caps over exposed threads.

**NOTE: End caps must be placed over exposed threads in food product areas to maintain NSF compliance.**

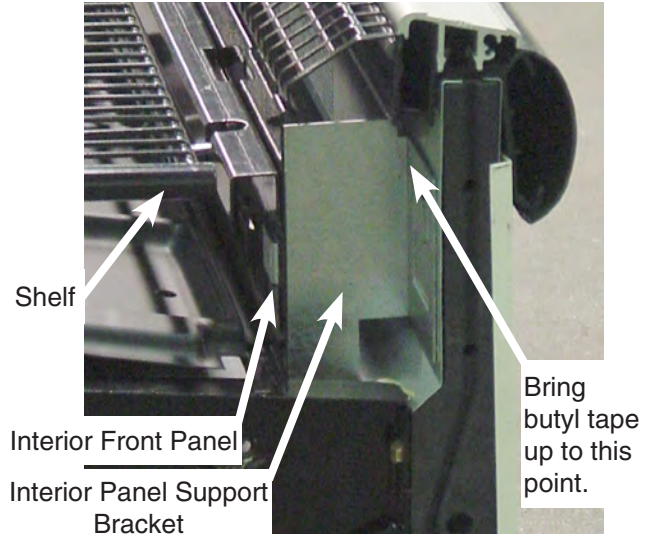
**Fasten Mullions**

1. Fasten mullions together with cap screws and hex nuts as shown on Page 1-8 at location **G**.

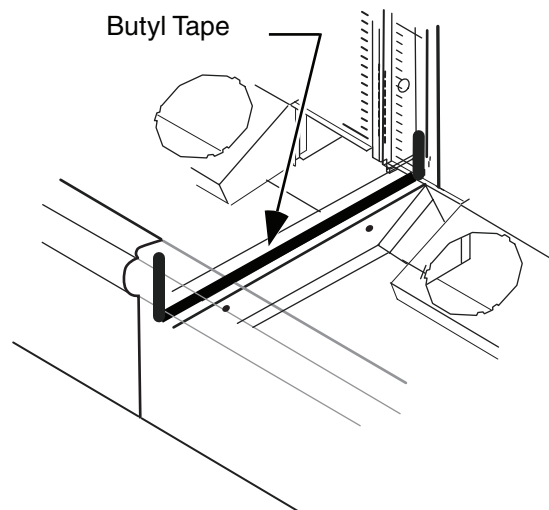


**Seal Merchandisers**

1. Remove interior front panel and interior panel support bracket to apply butyl tape. (Display pans were removed in earlier step.)



2. Apply butyl tape across the end shoe joint. Be sure to extend the tape up the back and front of the merchandiser. Silicone sealer may be applied around joining bolts on both sides in bottom shoe but isn't necessary if neoprene washers are used.



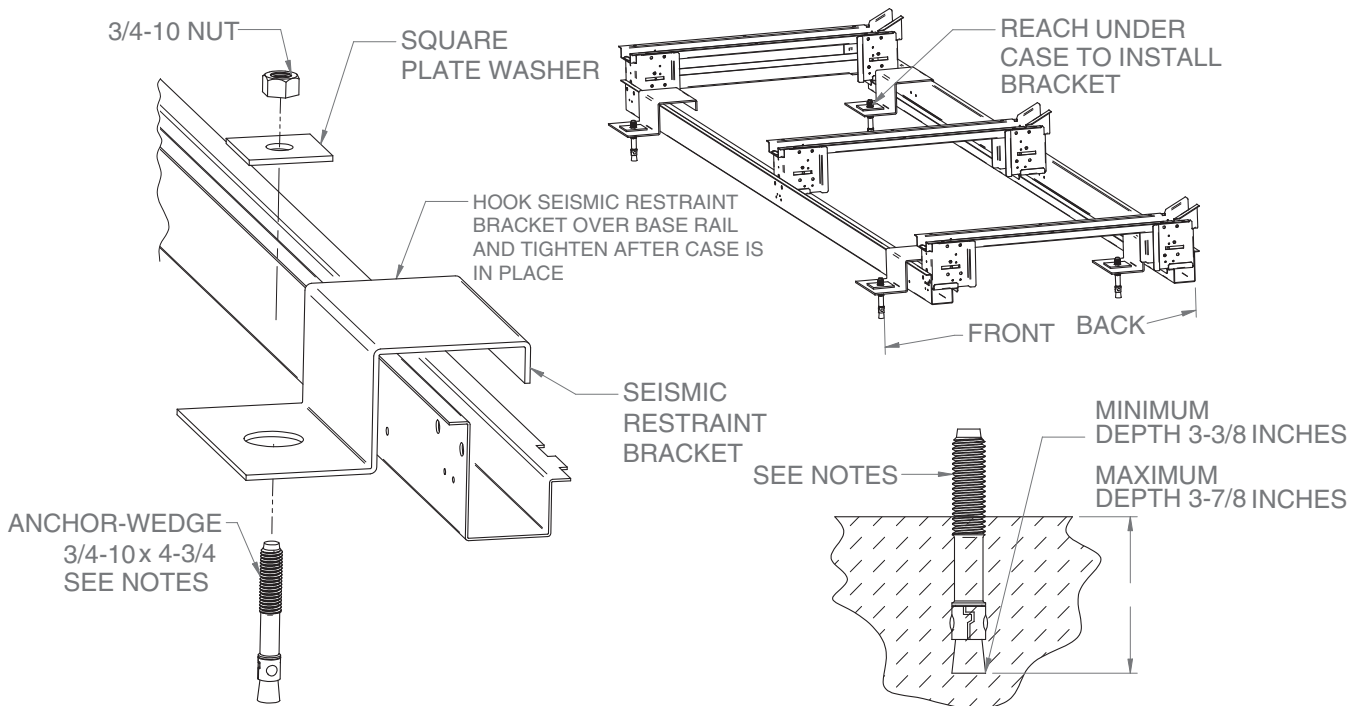
## INSTALLING SEISMIC RESTRAINTS

Door cases may require restraints in locations where cases are subject to potential seismic activity or in any instances where there is the potential for unwanted movement or tipping of the case(s).

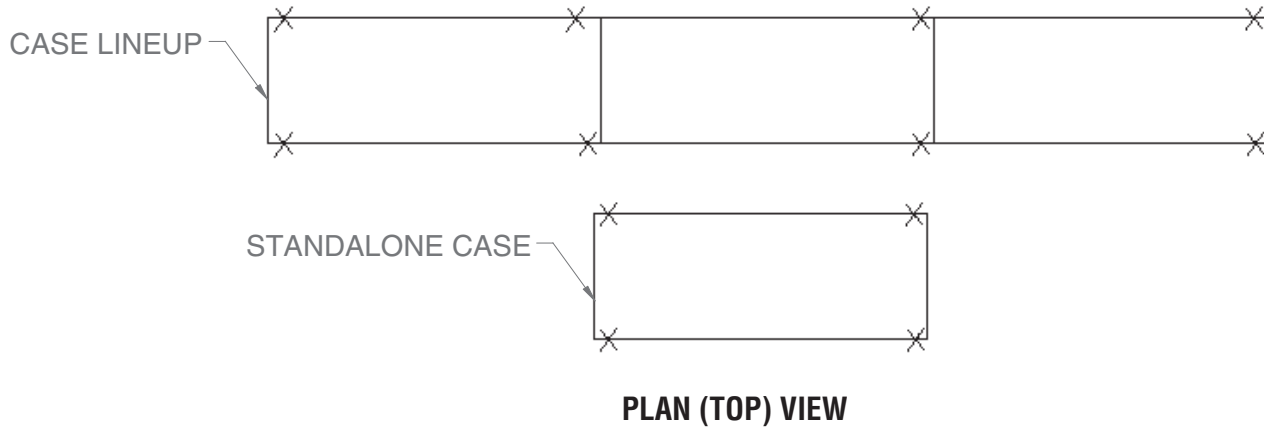
### To install these restraints:

Determine hole locations and set all anchors before case is in place. Avoid obstructions under case or on floor when planning anchor locations. Two brackets are required at each case joint and case end. See plan view on the next page. Equal number of brackets should be on front and back of case.

### FIELD INSTALLATION OF SEISMIC RESTRAINTS



**ANCHORS REPRESENTED BY "X"**



 **CAUTION**

**Caution: Tipping Hazard**  
**Case tipping may occur if cases are not properly leveled and secured.**

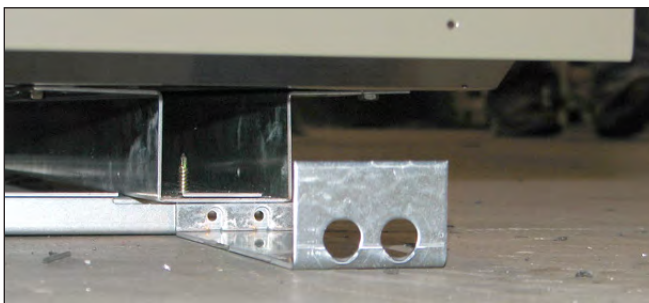


**Splashguard brackets MUST be installed before piping merchandiser.**

### INSTALL SPLASHGUARD BRACKETS

Position splashguard brackets at the front of the merchandiser, on the floor, at 4 foot intervals. Each bracket has a  $\frac{3}{8}$  in. (10 mm) slot at the rear of the bracket to allow some adjustment where it attaches to the merchandiser. Use a driver extension to tighten screws that secure the brackets.

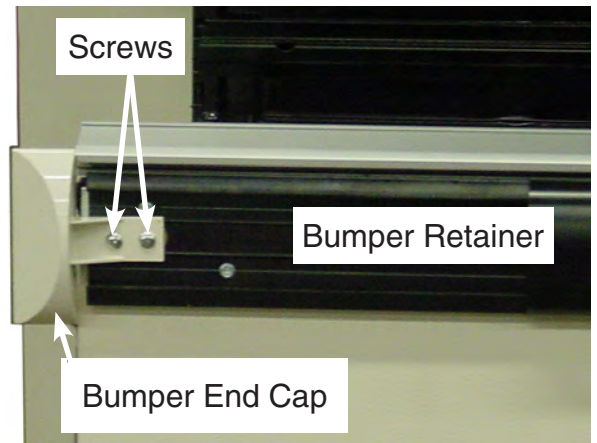
Once drip piping is complete, install splashguards as described in Section 3.



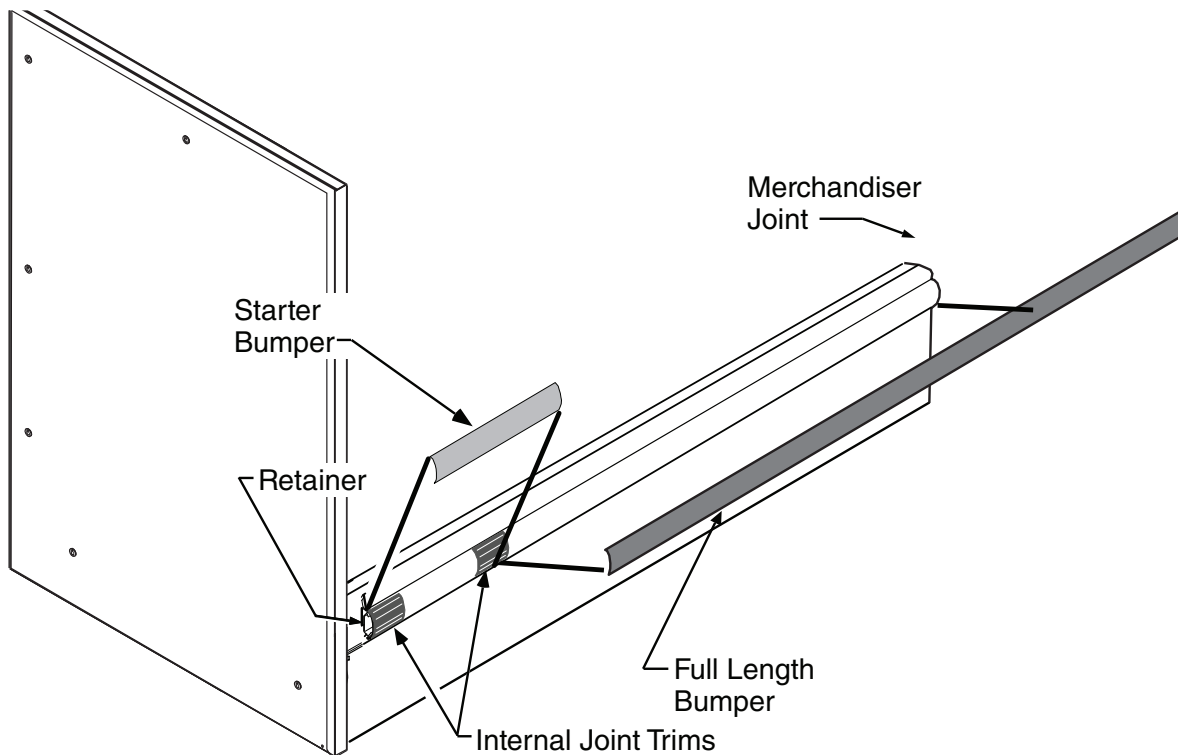
### OFFSETTING BUMPER

Offsetting the bumper helps to disguise the joint locations, giving the lineup a smoother look.

1. Locate starter bumper shipped with the left-end kit.
2. Remove factory installed bumper by pulling bumper away from bumper retainer. Be careful not to lose the internal joint trim on the bumper.
3. If not installed, install bumper end caps as shown.



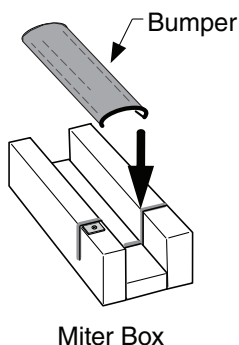
4. Starting at the left end of the line up, install the bumper starter section first. To install,
  - a. Position internal joint trims so that the first is flush to the left-end panel and the second is centered between the starter bumper and the full length bumper as shown.
  - b. Install full length bumpers and internal trims offset across joints. Make sure that no gaps exist between sections. Continue installing the bumpers the length of line up.



5. Once all except the last section of bumper have been installed refrigerate the merchandiser line up for at least six (6) hours. **The last section of bumper should be kept inside a cooler or refrigerated merchandiser during this time.** This will allow the bumper to contract.

6. Go to the right end of the line up and tap the bumper to close any gaps.

7. Measure and cut last sections of bumper. Use a miter box and fine-tooth saw to cut last bumper to length. Install the last section.



8. Remove protective film from bumper once installation is complete.



## INSTALLING END ASSEMBLIES

View End assemblies must be factory-installed. Solid End assemblies are normally factory installed. The following information is provided for retrofit or field installation.

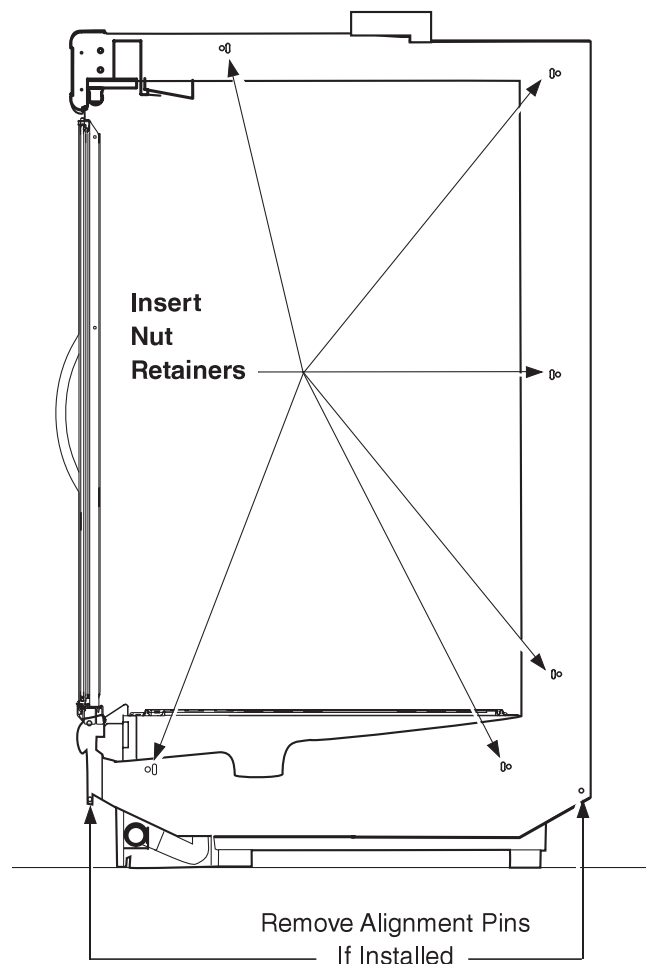
### 1. Prepare Merchandiser

- a. Install Nut Retainers into right end frame at locations shown.
- b. **Optional Front Rail Light Only**  
Check that end cap is in place before gaskets are applied. See Page 1-15 for details.

### 2. Apply Gaskets to End Frame as Follows:

- a. Apply the 1<sup>5</sup>/<sub>8</sub>-inch gasket around the top of the case as shown. It must be at the edge. Check to be sure that there are no gaps between gasket and merchandiser.
- b. Apply the 1<sup>5</sup>/<sub>8</sub> in. (41 mm) gasket on the metal frame upright as shown. Check to be sure that there are no gaps between merchandiser and gasket.
- c. Apply the 1 inch (25 mm) gasket on the metal merchandiser frame as shown across the bottom. Check to be sure that there are no gaps between merchandiser and gasket.
- d. Apply the 1<sup>5</sup>/<sub>8</sub> in. (41 mm) gasket on the metal case frame as shown the rear. Check to be sure that there are no gaps between merchandiser and gaskets.

### Ultra Low Front

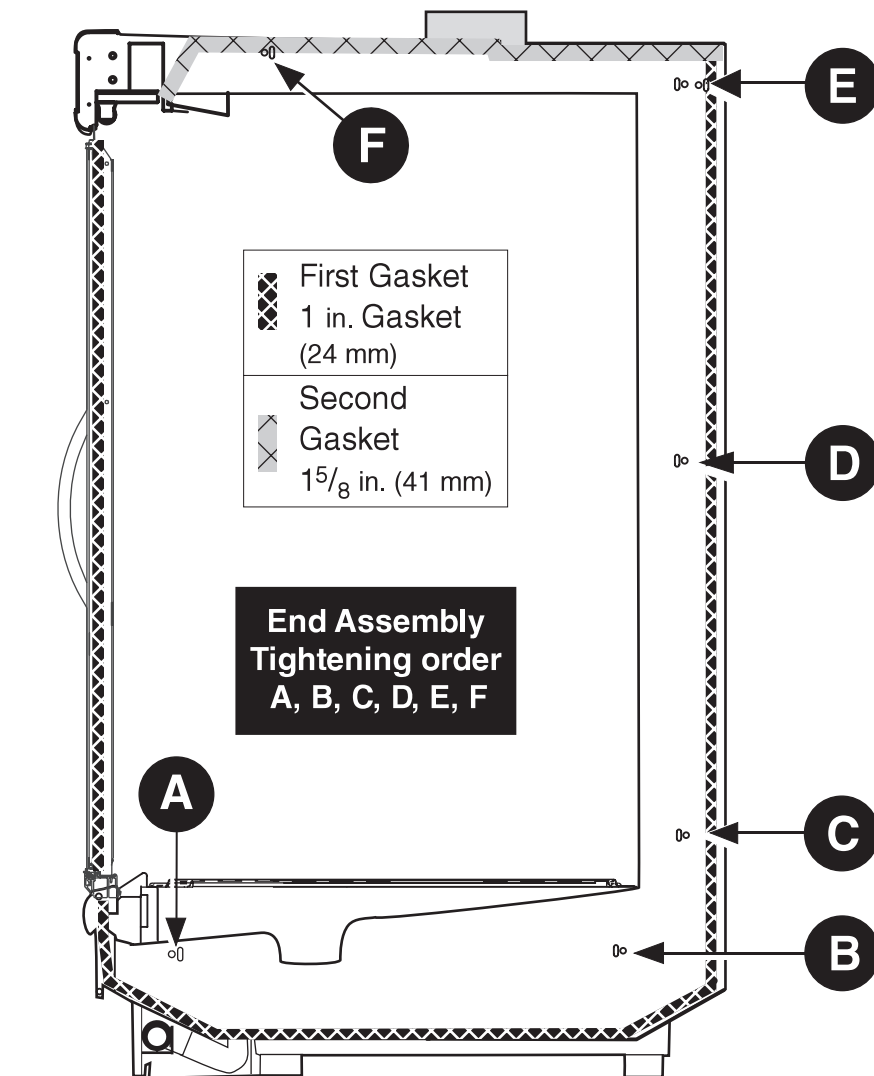


### IMPORTANT

- Do not stretch gasket, especially around corners.
- Do not butt gaskets; always overlap them as shown.
- Remove paper backing after gasket has been applied.
- *Perimeter gasket required by NSF.*
- End caps required for rail light.

Medium Temperature Ultra Low Front,  
**Excel with EcoVision II Doors**

Ultra Low Front



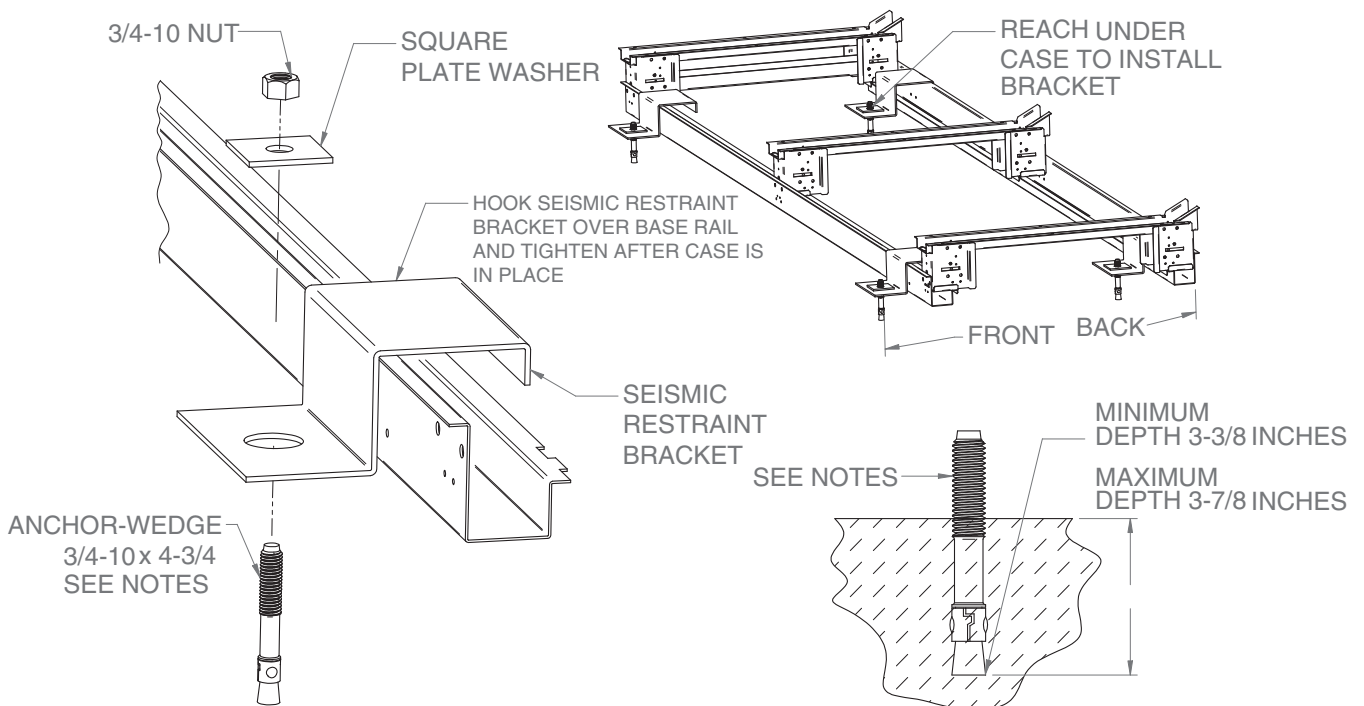
## INSTALLING SEISMIC RESTRAINTS

Door cases may require restraints in locations where cases are subject to potential seismic activity or in any instances where there is the potential for unwanted movement or tipping of the case(s).

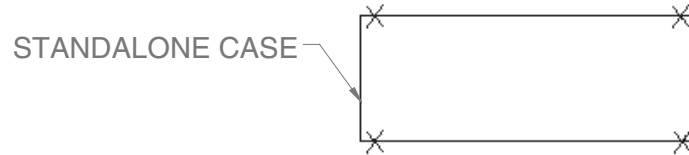
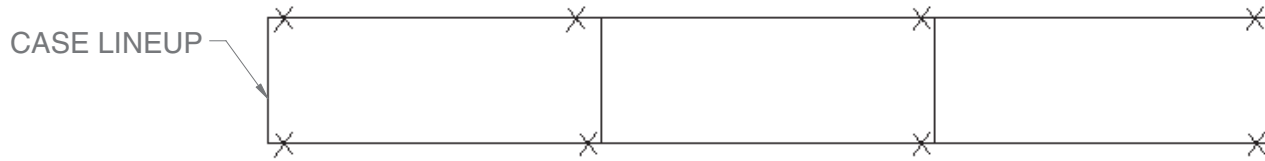
### To install these restraints:

Determine hole locations and set all anchors before case is in place. Avoid obstructions under case or on floor when planning anchor locations. Two brackets are required at each case joint and case end. See plan view on the next page. Equal number of brackets should be on front and back of case.

### FIELD INSTALLATION OF SEISMIC RESTRAINTS



**ANCHORS REPRESENTED BY "X"**



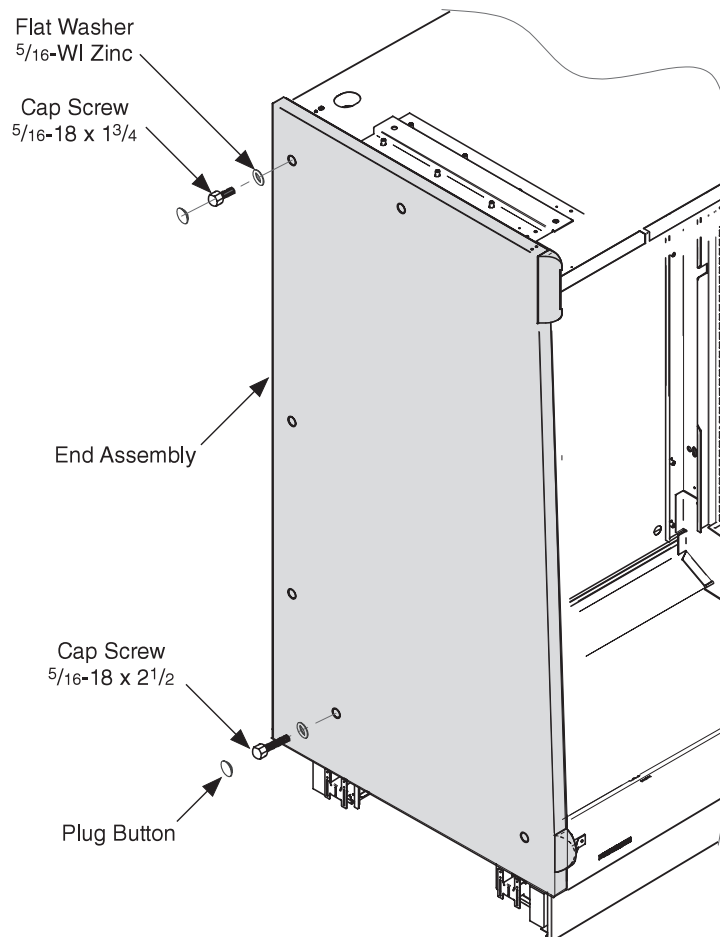
**PLAN (TOP) VIEW**

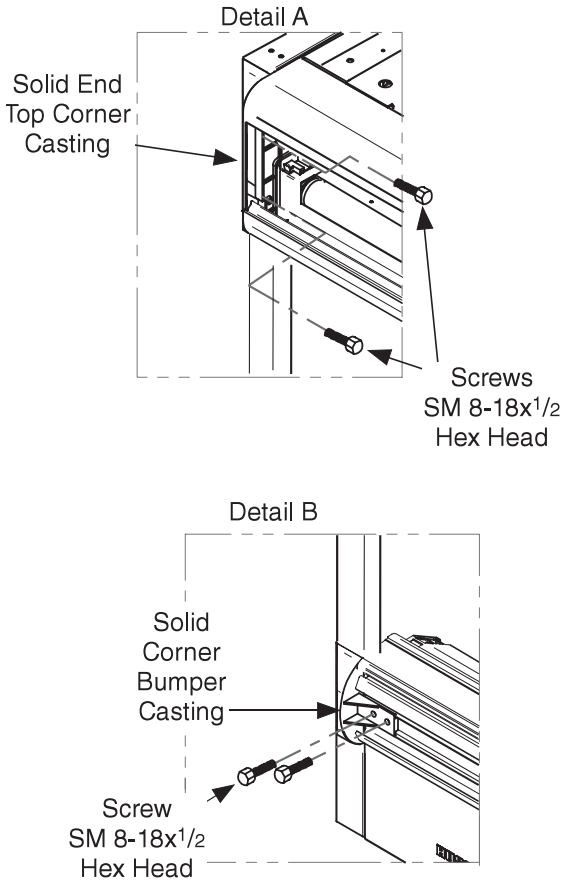
 **CAUTION**

**Caution: Tipping Hazard**  
**Case tipping may occur if cases are not properly leveled and secured.**

### 3. Fasten End Assembly to Merchandiser

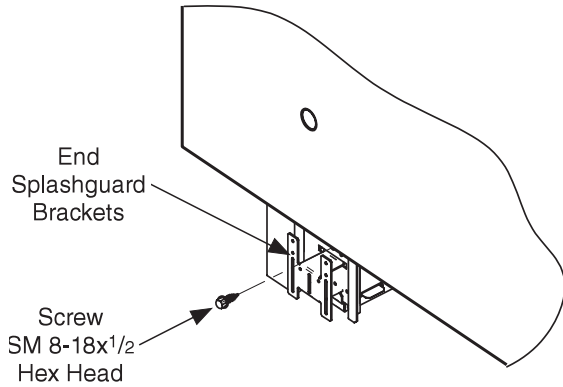
- a. Use Bolt and washer to fasten end assembly to merchandiser
- b. Use washer with Hex Nut to secure bolt and washer at front and canopy (Detail A and B), similar to joining process.
- c. Tighten in order shown on previous page. After fasteners have been tightened, insert Plug Buttons.
- d. Install Top and Bottom Corner Castings as shown below.





6. Install End Splashguard

a. Insert back of bracket through slot in leg. Use Screws to attach End Splashguard Retainers to end frame.

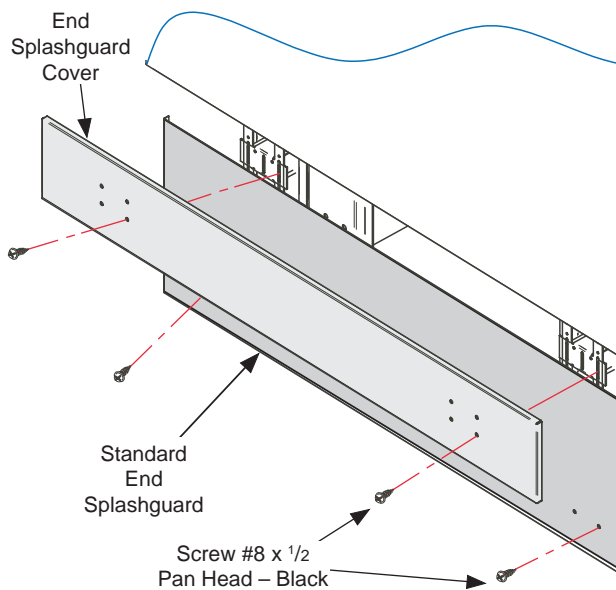
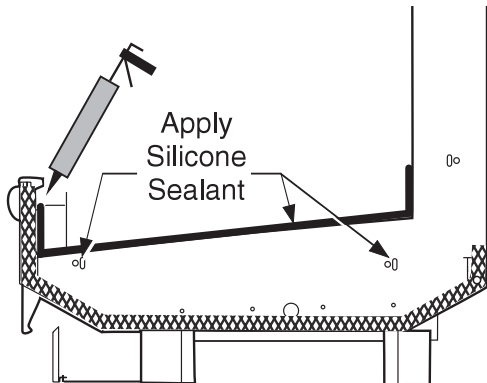


Align forward edge of End Splashguard with front splashguard, with lower edge resting on floor. Fasten End Splashguard to bracket with Screws.

c. Seal splashguard to floor with silicone.

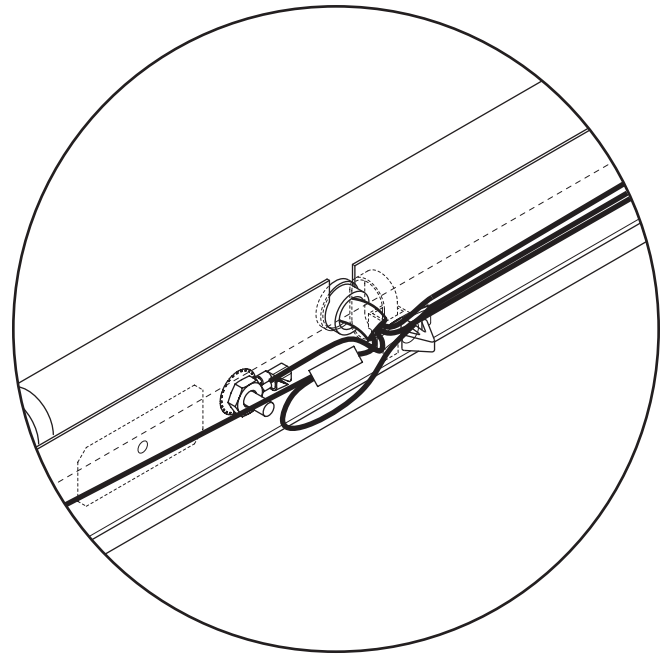
5. Seal End to End Frame

Remove front shelf and shelf support bracket. Apply a 1/2 in. bead of Silicone at the back of the case, starting at the first slot. Continue across the bottom and up the front as shown below. Use field-supplied silicone in any gap between front support bracket and end assembly.



Re-install bumpers as described beginning on Page 1-10. Note: Optional end bumpers are factory-installed only.

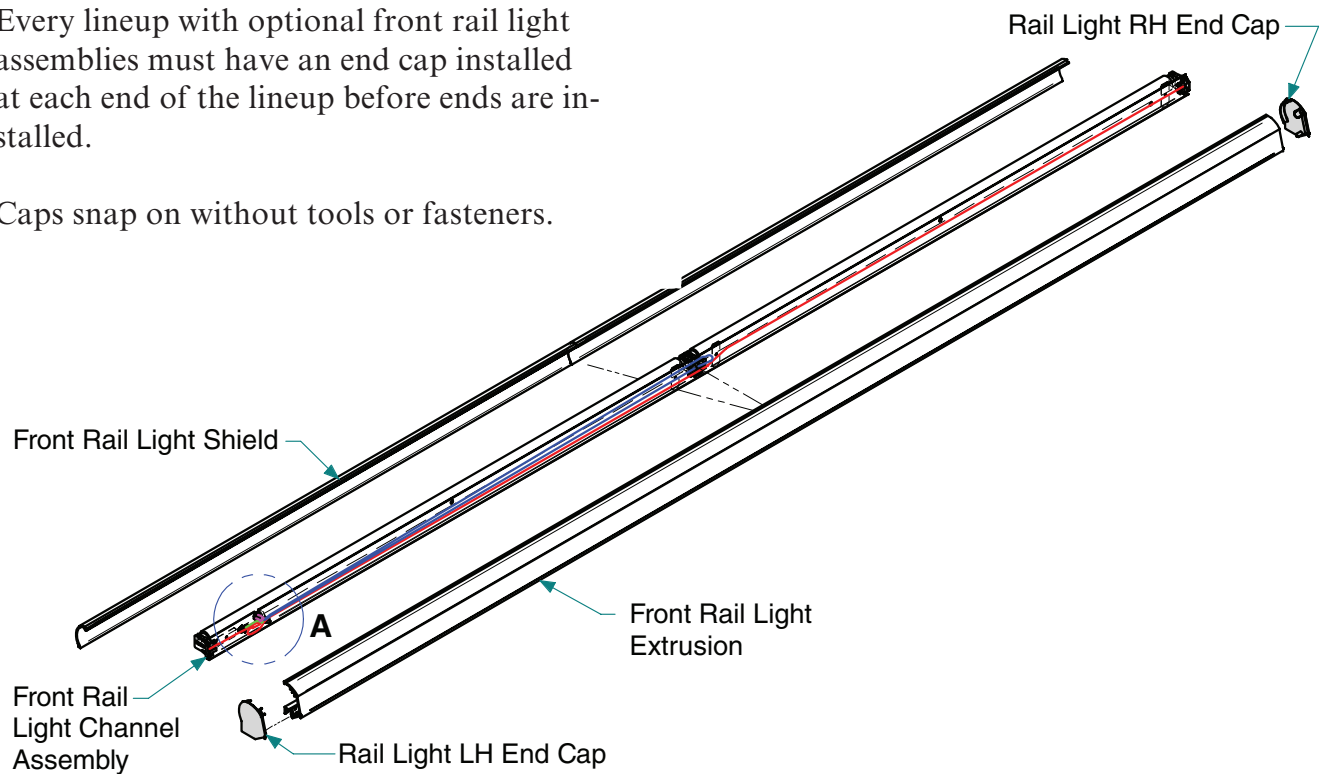
For reference, additional wiring detail is shown on the next page.

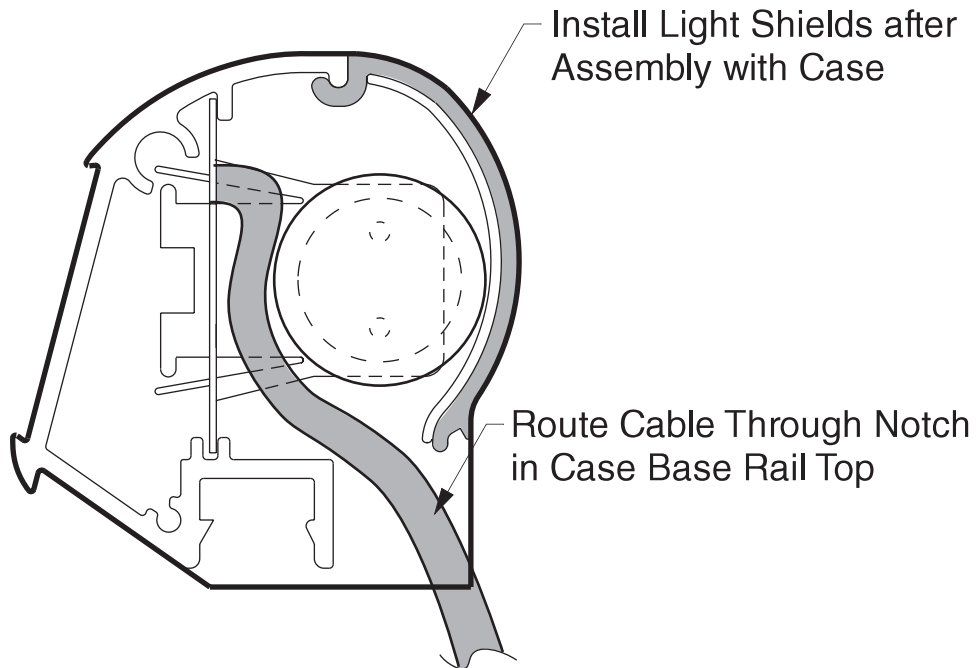


### OPTIONAL FRONT RAIL LIGHT

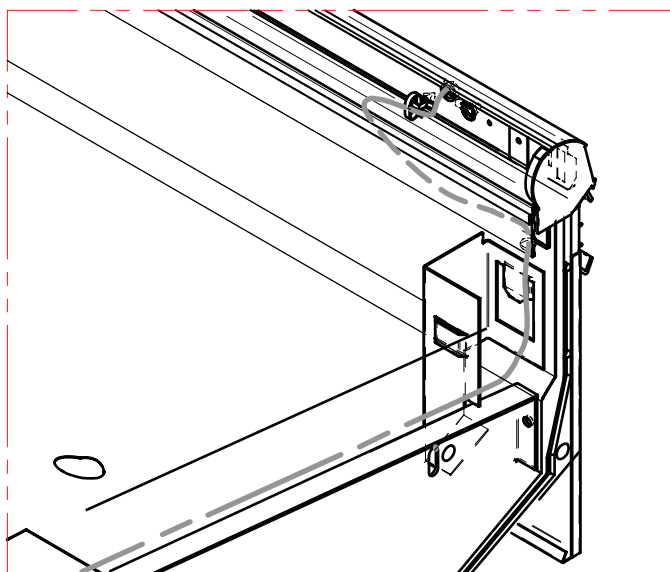
Every lineup with optional front rail light assemblies must have an end cap installed at each end of the lineup before ends are installed.

Caps snap on without tools or fasteners.





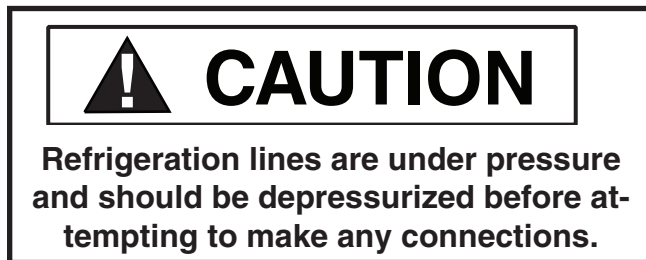
Rail Light End Cap LH View



## REFRIGERATION / ELECTRICAL

### REFRIGERANT

The correct type of refrigerant will be stamped on each merchandiser's serial plate. The merchandiser refrigeration piping is leak tested, factory sealed and pressurized. Before making refrigeration hookups, depress the universal line valve to ensure that coils have maintained pressure during shipment.



### REFRIGERANT PIPING

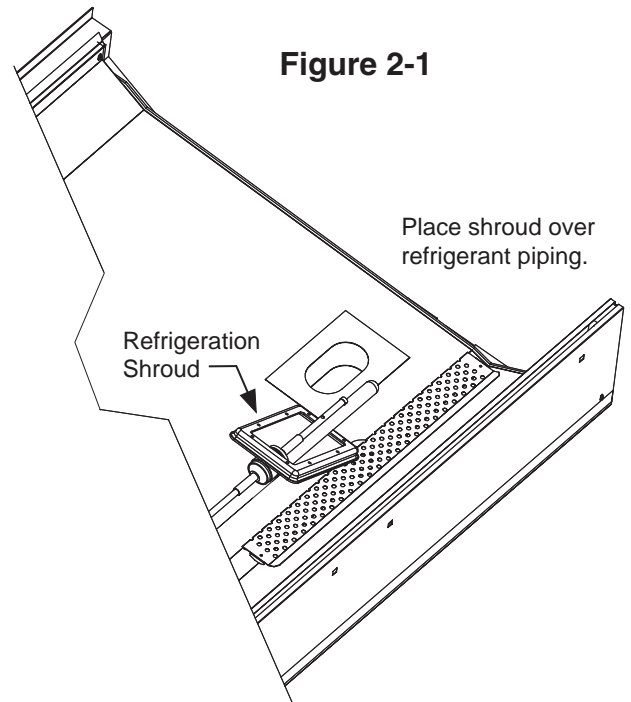
#### Connection Location

The refrigerant line connections are at the right-hand end of the merchandiser (as viewed from the front) beneath the display pans. A sticker marks the location of the connection. The installer must saw a hole to exit the merchandiser.

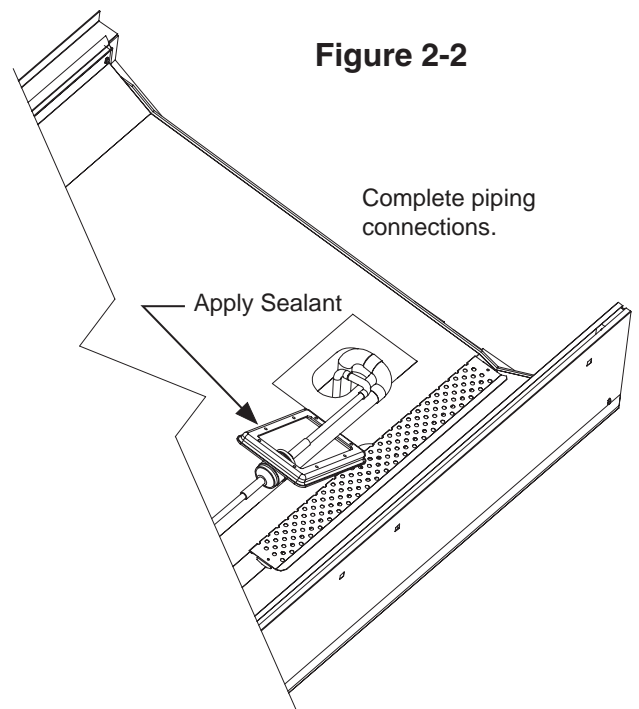
A refrigeration shroud ships with each merchandiser. Before making connections, place the refrigeration shroud over refrigeration piping so that when the shroud is rotated into place, it will be in the upright position. The Figure 2-1 shows the correct orientation.

Be careful not to burn, scorch or over-heat the shroud when making connections.

Once connections have been made, apply silicone sealant to the bottom of the shroud as shown in Figure 2-2.

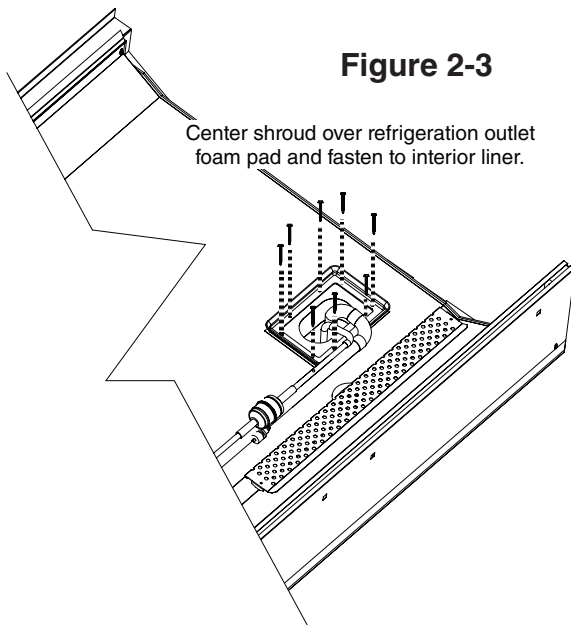


**Figure 2-1**



**Figure 2-2**

As shown in Figure 2-3, rotate and center the shroud over the refrigeration outlet foam pad, then fasten to the interior liner of the bottom.

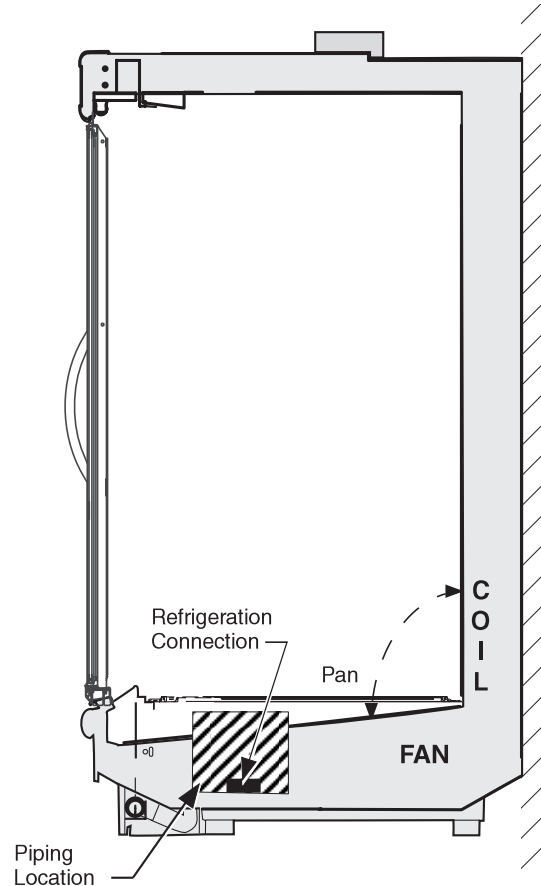


After connections have been made, seal this outlet thoroughly. Seal both the inside and the outside. We recommend using an expanding polyurethane foam insulation. Cover foam with silicone to prevent water from entering foam.

### Multiplexing

Piping of merchandisers operating on the same refrigeration system may be run from merchandiser to case. **DO NOT RUN REFRIGERANT LINES THROUGH MERCHANDISERS THAT ARE NOT ON THE SAME REFRIGERATION SYSTEM BRANCH** as this may result in poor refrigeration control and compressor failure.

Interconnecting piping inside the merchandiser must be located as shown below to allow room for lifting the hinged fan plenums and for clearance beneath the display pans. Alternately, the interconnecting piping may be run outside the merchandiser in the area shown.



### Line Sizing

Refrigerant lines should be sized as shown on the refrigeration legend that is furnished for the store or according to ASHRAE guidelines. Refer to the information on the next page for branch line piping of Hussmann Equipment.

### Oil Traps

P-traps (oil traps) must be installed at the base of all suction line vertical risers.

### Pressure Drop

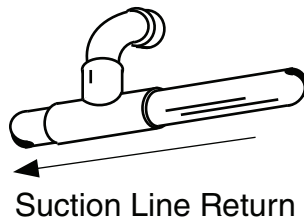
Pressure drop can rob the system of capacity. To keep the pressure drop to a minimum, keep the refrigerant line run as short as possible using a minimum number of elbows. Where elbows are required, USE LONG RADIUS ELBOWS ONLY.

## INSULATION

Additional insulation for the balance of the liquid and suction lines is recommended whenever condensation drippage is objectionable or lines are exposed to ambient conditions.

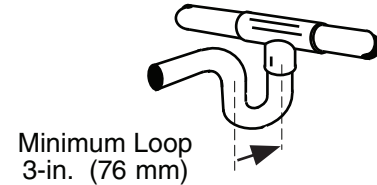
## SUCTION LINE

- Pitch in direction of flow.
- May be reduced by one size at one third of merchandiser run load and again after the second third. Do not reduce below the merchandiser suction line size.
- Merchandiser suction lines should enter at the top of the branch line.



## LIQUID LINE

- May be reduced by one size after one half the merchandiser run load. Do not reduce below the merchandiser liquid line connection size.
- Take-offs to merchandiser liquid lines should exit the bottom of the branch liquid line. Provide an expansion loop for each evaporator take-off (minimum 3 in. [76 mm] loop).



Liquid Line Take Off

## REFRIGERATION THERMOSTAT

The bulb for the optional refrigeration thermostat is located approximately 12 in. (305 mm) above the coil and 6 ft (1829 mm) from the left-hand end (facing front) of the merchandiser.

The optional refrigeration thermostat is located 3½ ft (1067 mm) from the left-hand end, just past the raceway. On wide island models, the thermostat body is located on the serial plate side (front) of the merchandiser.

## DEFROST TERMINATION THERMOSTAT

The standard disc type defrost termination thermostat is not adjustable. This thermostat is clamped to the suction line of the coil on the left-hand (facing front) end of the merchandiser.

**E-Plus** models do not use a defrost termination thermostat and are to be time terminated only.

## DEFROST SEQUENCES

These merchandisers require defrost cycles for proper operation. Refer to the data sheets for application data.

The Time Clock initiates defrost. The evaporator fans continue to circulate air across the evaporator coil, melting any frost build-up. Defrost can be terminated by either temperature or time.

### Temperature Termination

Temperature termination should be used for the following types of installations:

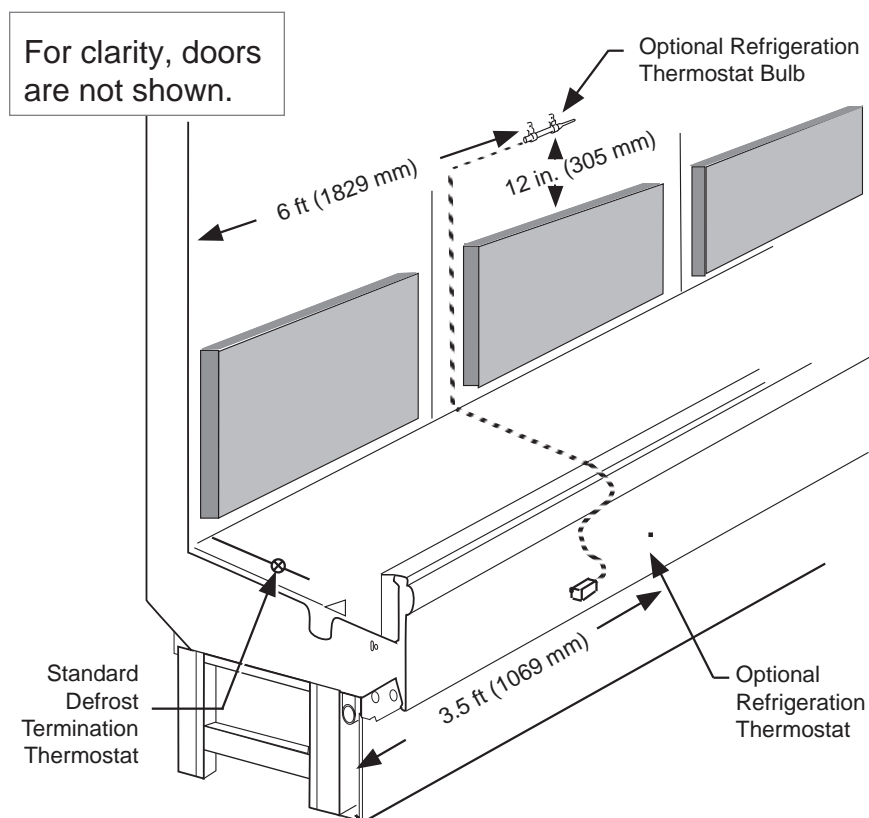
1. Parallel systems with EPRs or suction stop solenoids
2. Single compressor units without pump-down cycle.

### Time Termination

Time termination should be used for the following types of installations:

1. All E-Plus models;
2. Parallel systems with thermostat and liquid solenoid; and
3. Single compressor units with pump-down.

To use time termination, simply do not wire the termination thermostat.



**MERCHANDISER ELECTRICAL DATA**

Technical data sheets are included with this manual. The data sheets provide merchandiser electrical data, electrical schematics, parts lists and performance data. Refer to the technical data sheets and merchandiser serial plate for electrical information.


**ELECTRICAL CONNECTIONS**

All wiring must be in compliance with NEC and local codes. All electrical connections are to be made in the electrical raceway or *Handy Box*.

**FIELD WIRING**

Field wiring must be sized for component amperes stamped on the serial plate. Actual ampere draw may be less than specified. Field wiring from the refrigeration control panel to the merchandisers is required for defrost termination thermostats and for optional refrigeration thermostats. When multiple merchandisers are on the same defrost circuit, the defrost termination thermostats are wired in series.

**ALWAYS CHECK THE SERIAL PLATE FOR COMPONENT AMPERES.**



**CAUTION**

**Optional T8 rail lights and optional Quick Connect spray hose or field-installed misting system shall not be used together.**

**IDENTIFICATION OF WIRING**

Leads for all electrical circuits are identified by colored plastic bands. These bands correspond to the *color code sticker* (shown below) located inside the merchandiser’s raceway cover.

**WIRING COLOR CODE**

Leads for all electrical circuits are identified by a colored plastic band: neutral wire for each circuit has either White insulation or a White plastic sleeve in addition to the color band.

PINK..... REFRIG. THERMOSTAT LOW TEMP.	ORANGE OR
LIGHT BLUE . REFRIG. THERMOSTAT NORM TEMP.	TAN.....LIGHTS
DARK BLUE.. DEFROST TERM. THERMOSTAT	MAROON...RECEPTACLES
PURPLE ..... CONDENSATE HEATERS	YELLOW....DEFROST HEATERS 120V
BROWN..... FAN MOTORS	RED .....DEFROST HEATERS 208V
GREEN* ..... GROUND	*EITHER COLORED SLEEVE OR COLORED INSULATION

**ELECTRICIAN NOTE: Use copper conductor wire only.  
MERCHANTISER MUST BE GROUNDED**

**THESE ARE MARKER COLORS WIRES MAY VARY.**

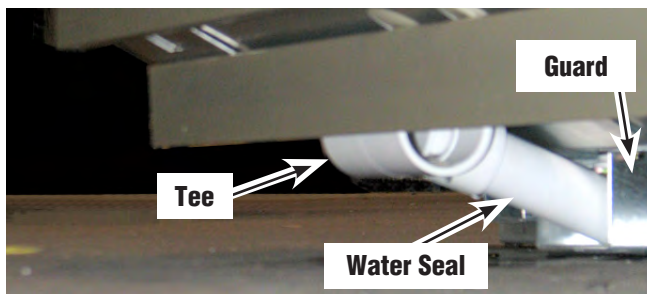
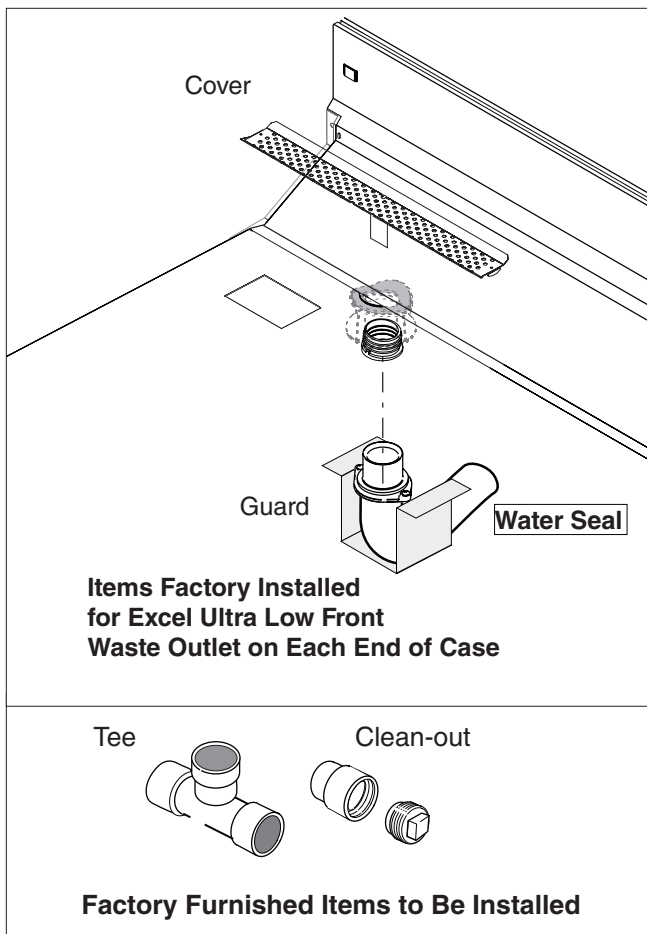
**2-6 REFRIGERATION / ELECTRICAL**

Notes:

## DRIP PIPING AND SPLASHGUARDS

### WASTE OUTLET AND WATER SEAL

Each ultra low front merchandiser has two waste outlets located in front of the fan plenum 12 inches (305 mm) from either end. Water seals are factory-installed with waste outlets to prevent air leakage and insect entrance into the merchandiser. Do not remove the guard installed under the water seal—it prevents damage during shipment, installation and use. Two tees and clean-outs are supplied for each merchandiser.



**Splashguard brackets MUST be installed before piping merchandiser.**

### INSTALLING DRIP PIPING

Poorly or improperly installed drip pipes can seriously interfere with the merchandiser’s operation and result in costly maintenance and product losses.

Optional drip pipe arrangements are shown on the next page. It is the installing contractor’s responsibility to consult local agencies for local code requirements. Assemble the components using field-supplied PVC primer and glue according to the manufacturers direction.

Please follow the recommendations listed below when installing drip pipes to ensure proper installation.

1. Never use drip piping smaller than the nominal diameter of the pipe or water seal supplied with the merchandiser.
2. When connecting drip piping, the “water seal” must be used as part of the drip piping to prevent air leakage or insect entrance. Never use two water seals in series in any one drip pipe. **DOUBLE WATER SEALS IN SERIES WILL CAUSE AN AIR LOCK AND PREVENT DRAINING.**
3. Pitch the drip piping in the direction of flow. **There should be a minimum pitch of 1/4 in. per ft (20 mm per 1 m).**
4. Avoid long runs of drip piping. Long runs make it impossible to provide the pitch necessary for good drainage.

**DRIP PIPING AND SPLASHGUARDS**

5. Provide a suitable air break between flood rim of the floor drain and outlet of drip pipe. To meet code on low base merchandisers, it may be necessary to install a field-supplied drip pipe reducer.



An alternative is to cut the last section of drip pipe at an angle.

6. Prevent drip pipes from freezing:

- a. Do NOT install drip pipes in contact with uninsulated suction lines. Suction lines should be insulated with a nonabsorbent insulation material.
- b. Where drip pipes are located in dead air spaces, such as between merchandisers or between a merchandiser and a store wall, provide means to prevent freezing.

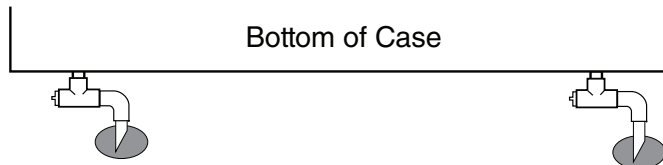


**ATTENTION  
INSTALLER**

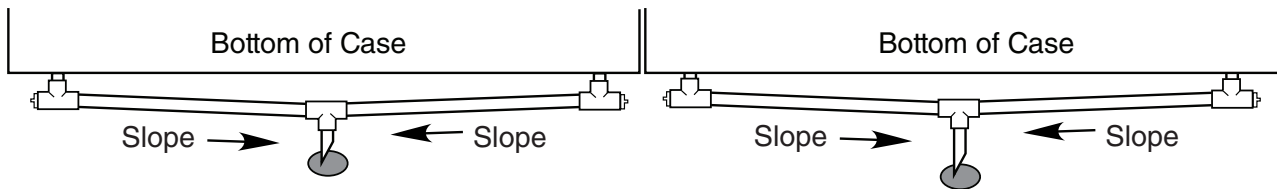
**It is the installing contractor's responsibility to consult local agencies for local code requirements.**

**IMPORTANT**

**ONE FLOOR DRAIN IS REQUIRED FOR EACH MERCHANDISER**



Attach tee to factory-installed water seal ó Do NOT install additional water seals!



Always Slope Toward Floor Drain

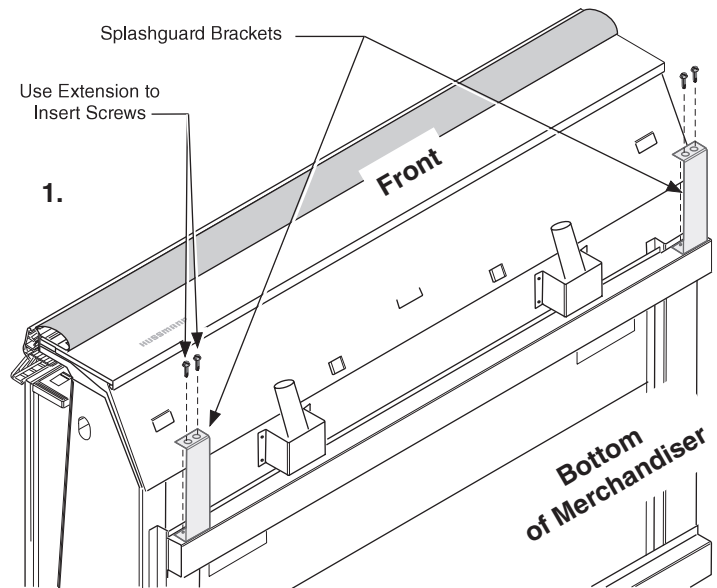
**Optional Excel Ultra Low Front Drip Piping Arrangements**

## INSTALLING SPLASHGUARDS

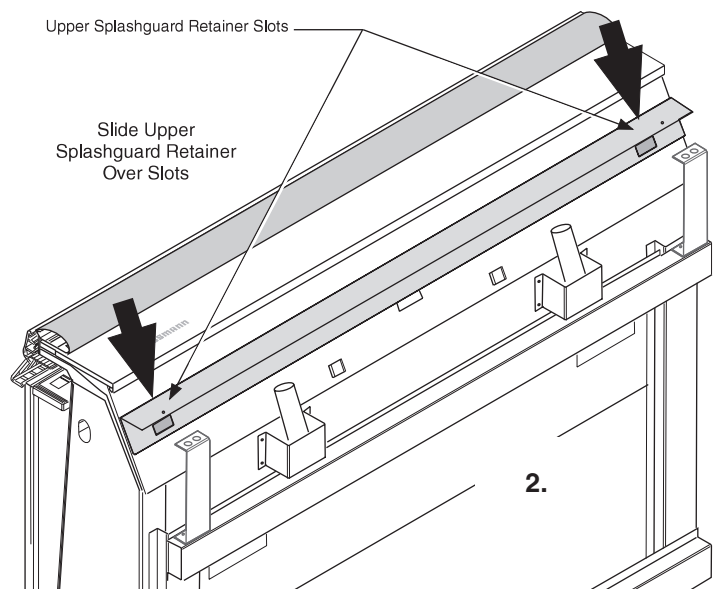
The splashguard is shipped inside each merchandiser. **AFTER** merchandisers have been leveled and joined, and all drip piping, electrical and refrigeration work has been completed, install the splashguard.

### To Install Splashguards:

1. Check to be sure that all splashguard retainers are level with the floor and fastened to the rail.



2. Align the tabs in the upper splashguard support with the slots extending out from the front color panel, then slide the upper splashguard into place. The upper splashguard support should be level.



3. Position splashguard bottom slot over the splashguard retainer on each end of the merchandiser, and align the screw slots with the hold in the upper support. Fasten the splashguard to the upper support with self-drilling screws.

4. Seal the splashguard to the floor using silicone sealant.

If silicone will not fill gaps caused by uneven floor, field-supplied cove trim should be used.

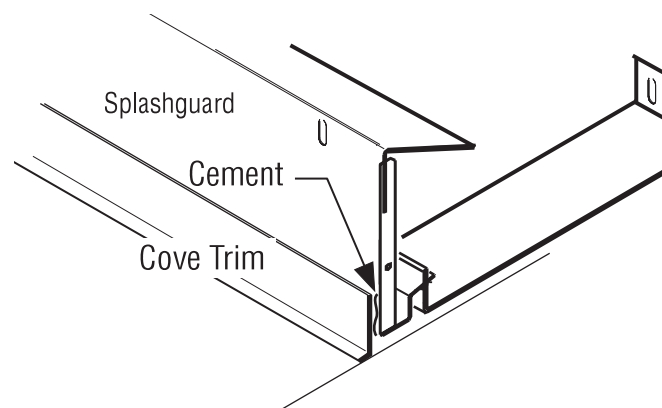
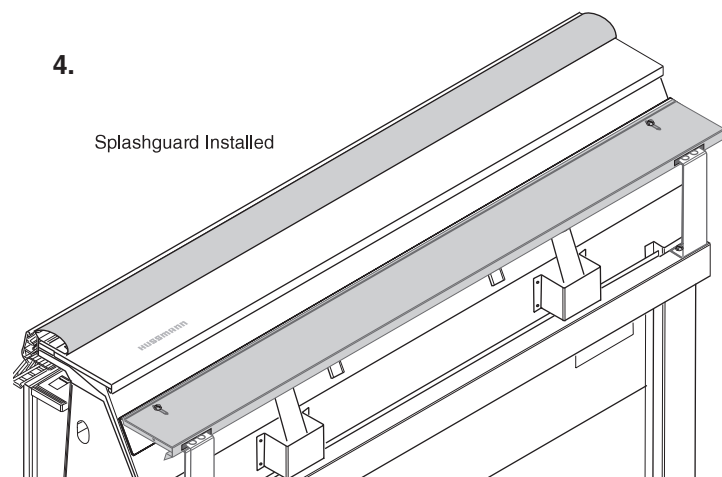
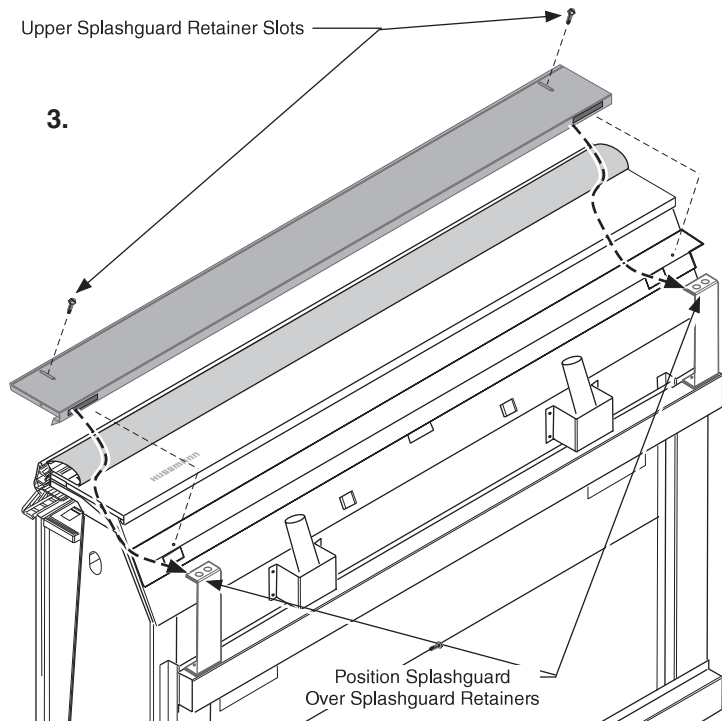
**To install the cove trim to the splashguard:**

1. Remove all dirt, wax and grease from the area of the splashguard where adhesion will be necessary to ensure a secure installation.

2. Apply a good contact cement to the cove trim and allow proper drying time according to the directions supplied with the cement.

3. Install the trim to the splashguard so that it is lying flush with the floor. **DO NOT SEAL THE TRIM TO THE FLOOR.**

4. **If required by local health codes** the Cove Trim may be sealed to the floor, using a silicone type sealer. Sealant must be removed and replaced when servicing.

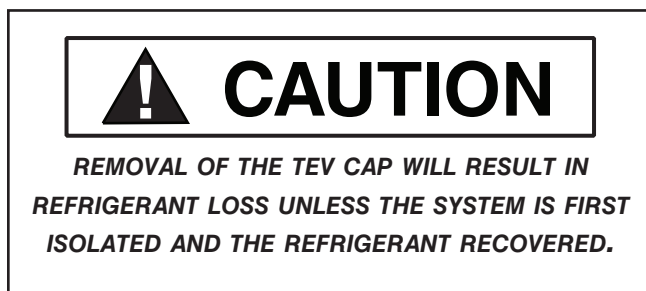


## START UP / OPERATION

### START UP

See the merchandiser's Technical Data Sheet (TDS) for refrigerant settings and defrost requirements. Bring merchandisers down to the operating temperatures listed on the data sheet.

Each four foot section has its own evaporator coil and pre-set non-adjustable thermostatic expansion valve (TEV). No adjustment is required. **DO NOT REMOVE THE CAP ON THE TEVs.** This cap is to be removed only for valve disassembly. Removal of this cap during case maintenance will result in refrigerant loss unless the system is first isolated and the refrigerant recovered.



The TEV has been factory set to provide the recommended performance settings as specified on the merchandiser data sheets.

### LOAD LIMITS

Each merchandiser has a load limit. Shelf life of perishables will be short if load limit is violated. **AT NO TIME SHOULD MERCHANDISERS BE STOCKED BEYOND THE LOAD LIMITS INDICATED.**

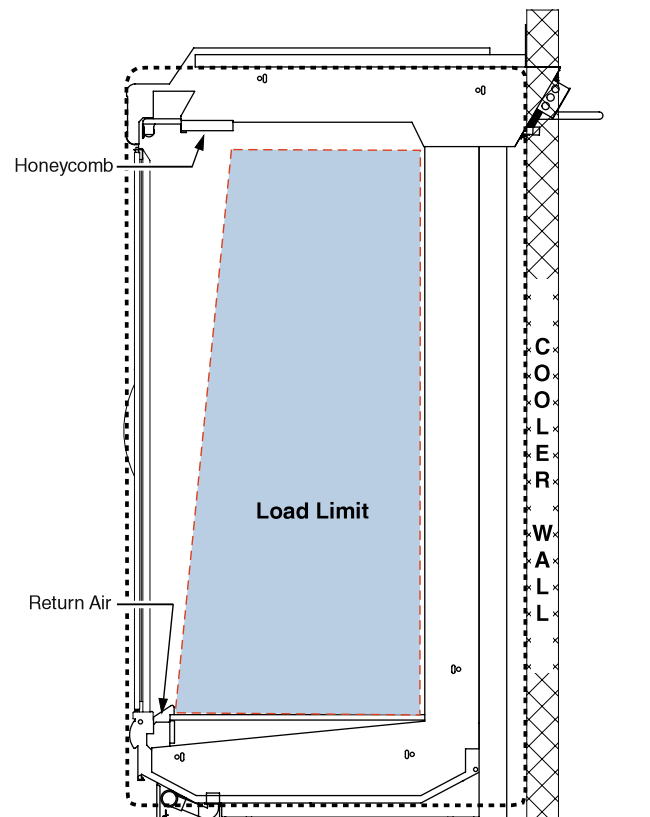
**DO NOT BLOCK HONEYCOMB OR RETURN AIR GRILLE.**

### STOCKING

Product should **NOT** be placed inside of merchandisers until merchandiser is at proper operating temperature.

Proper rotation of product during stocking is necessary to prevent product loss. Always bring the oldest product to the front and set the newest to the back.

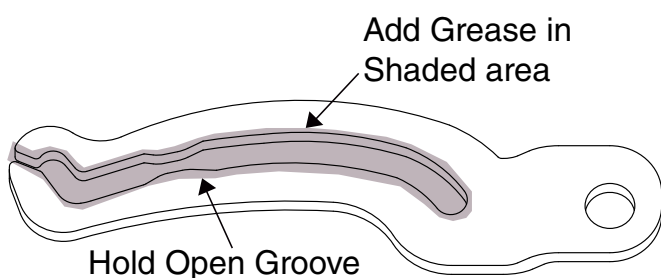
AIR DISCHARGE AND RETURN FLUES MUST REMAIN OPEN AND FREE OF OBSTRUCTION AT ALL TIMES to provide proper refrigeration and air curtain performance. Do not allow product, packages, signs, etc. to block these grilles. Do not use non-approved shelving, baskets, display racks, or any accessory that could hamper air curtain performance.



Medium Temperature Ultra Low Front,  
**Excel with EcoVision II Doors**

## DOOR HOLD OPEN

The merchandiser's EcoVision II doors have a hold open latch that allows the doors to remain in an open position. This feature is especially useful for stocking the merchandiser with product or cleaning the merchandiser's interior. The hold open latch is located on each door near the bottom door. Apply grease every six months to the door hold open cam to ensure smooth operation.

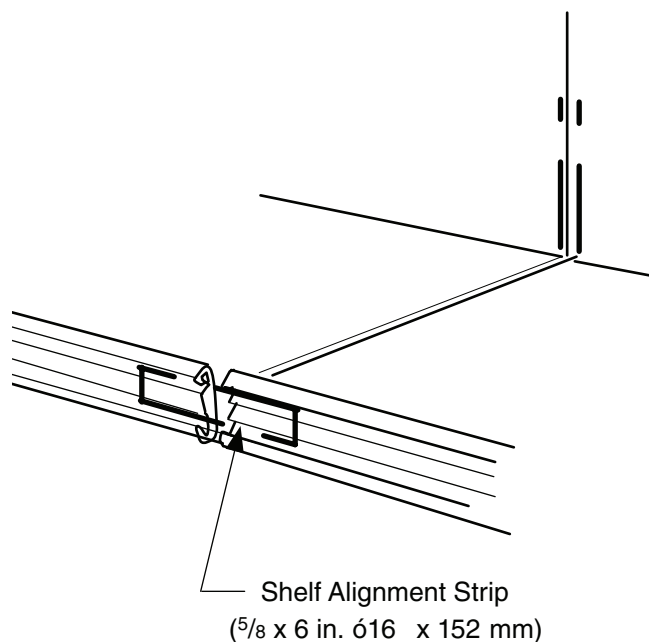


## MULTI-DECK SHELF ALIGNMENT (Optional)

Taped to one of the shelves of each merchandiser is a small plastic bag containing shelf alignment strips. These strips are designed to enhance the appearance of the shelves by aligning the front edge of each shelf with that of an adjacent shelf.

When installing shelves:

1. Insert one of the alignment strips into the slot behind the front edge of each shelf.
2. After all shelves are installed, slide the strip across the shelf joint wherever two shelves are adjacent. This will lock them together.

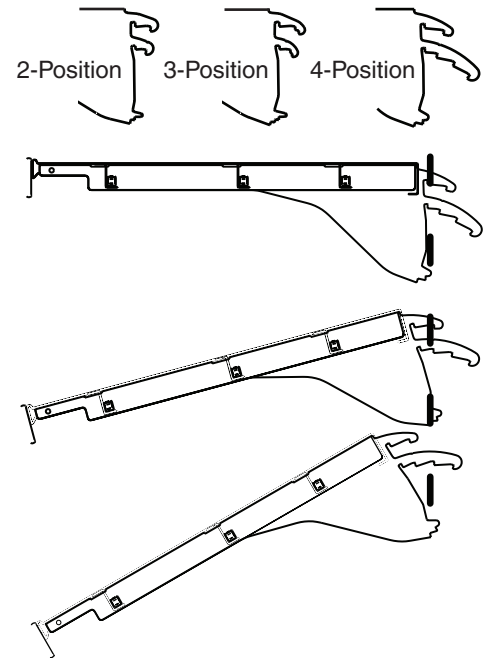


## MULTI-DECK SHELF CONFIGURATION

The bottom display shelves can be adjusted to accommodate shallow or volume displays (bulky items such as hams or chickens). The upper shelves are individually mounted in 1 in. (25 mm) increments and have two-, three-, or four-position brackets permitting shelves to be placed in a flat or down-tilt position (see illustration). Front product stops are recommended when shelves are placed in the down-tilt position.

Merchandise performance will be degraded if peg shelves are used without baffles.

Unauthorized specialty shelving may cause poor merchandise performance also. Consult your Hussmann representative to ensure optimum performance of all Hussmann equipment.



### SHELF MAXIMUM WEIGHT LIMITS

Hussmann merchandiser shelves are designed to support the maximum weight load limits as indicated in this table.

Exceeding these maximum weight load limits may cause damage to the shelf or shelves, damage to the merchandiser, damage to store products, and potentially create a hazardous condition for customers and staff. Exceeding the indicated maximum weight load limits constitutes misuse as described in the Hussmann Limited Warranty.

### INSTALLING FDA/NSF REQUIRED THERMOMETER

The following pages provide the same information that ships with the thermometer.

**This requirement does not apply to display refrigerators intended for bulk produce** (refer to page 1-1).

Please note that the tape cannot be exposed after installation.

### Weight Limits for Merchandiser Shelving

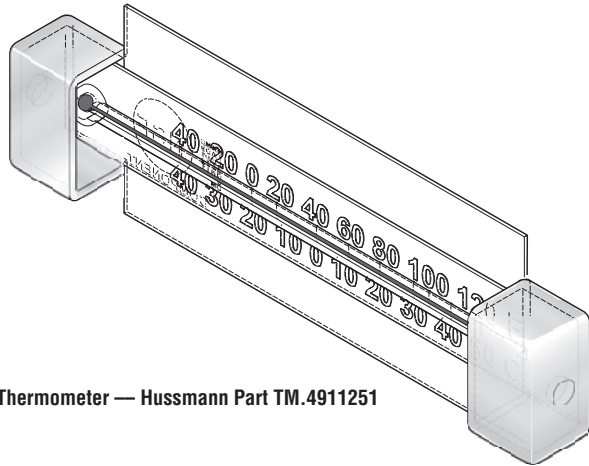
Nominal Shelf Depth	Maximum Load Limit
12 in. (305 mm)	125 lb (56.7 kg)
14 in. (357 mm)	125 lb (56.7 kg)
16 in. (406 mm)	200 lb (90.7 kg)
18 in. (457 mm)	200 lb (90.7 kg)
20 in. (508 mm)	250 lb (113.4 kg)
22 in. (559 mm)	250 lb (113.4 kg)
24 in. (610 mm)	250 lb (113.4 kg)
Heavy Duty Beverage Shelf 16 in. (406 mm)	300 lb (136 kg)
Heavy Duty Beverage Shelf 18 in. (457 mm)	320 lb (145.1 kg)
Heavy Duty Beverage Shelf 20 in. (508 mm)	350 lb (158.8 kg)
Heavy Duty Beverage Shelf 22 in. (559 mm)	350 lb (158.8 kg)
Heavy Duty Beverage Shelf 24 in. (610 mm)	350 lb (158.8 kg)

\*Shelf load limits at 0° tilt

### Merchandiser Shelf Depths

	Recommended	Maximum
Narrow (37 in. Merchandiser Depths)	16 in. (406 mm)	18 in. (457 mm)
Standard (42 in. Merchandiser Depths)	22 in. (559 mm)	24 in. (610 mm)

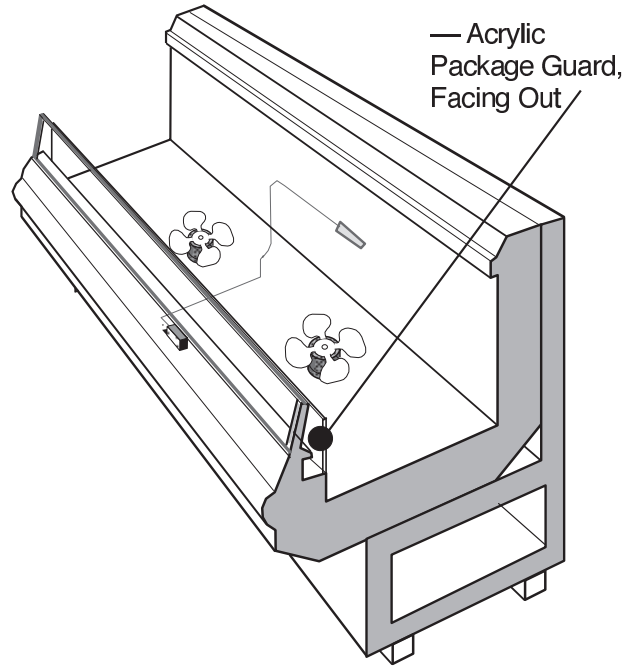
# This is an NSF-7 & US FDA Food Code Required Thermometer



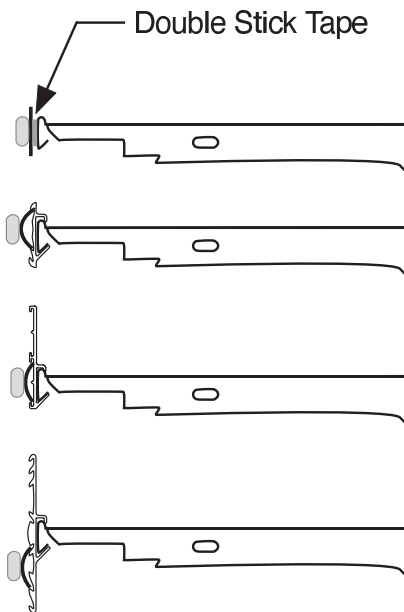
Thermometer — Hussmann Part TM.4911251

Hussmann Corporation • 12999 St. Charles Rock Road • Bridgeton, MO 63044-2483  
U.S. & Canada 1-800-922-1919 • Mexico 1-800-522-1900 • www.hussmann.com  
© Hussmann Corporation

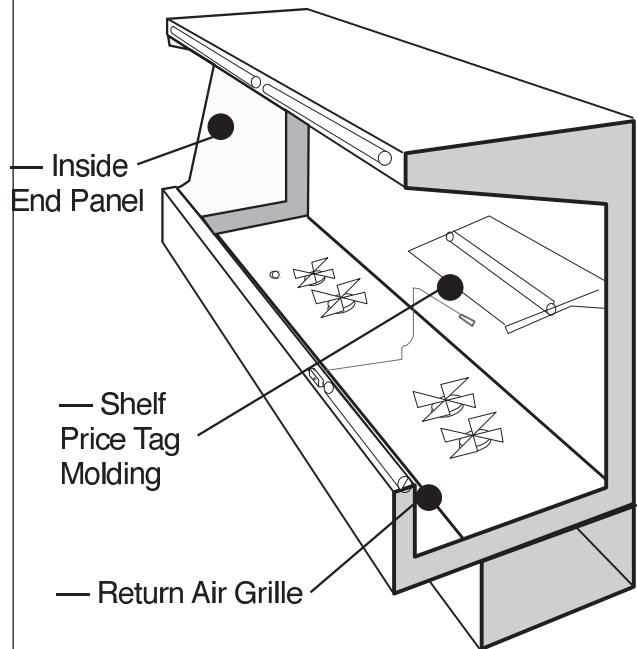
## Suggested Mounting Locations in Single Deck Glass Front Impact Merchandisers



— Acrylic Package Guard, Facing Out



Flexible Plastic Fits in Price Tag Moldings



— Inside End Panel

— Shelf Price Tag Molding

— Return Air Grille

## Suggested Mounting Locations in Multi-deck Merchandisers

Medium Temperature Ultra Low Front,  
**Excel with EcoVision II Doors**

# Important – Please read!

---

This thermometer is provided in response to United States Food and Drug Administration (US FDA) Food Code [ <http://www.fda.gov/> ] and National Sanitation Foundation (NSF / ANSI) Standard 7 [ <http://www.nsf.org/> ]

---

Each installation will be different depending on how the unit is stocked, shopping patterns in the department and ambient conditions of the store. The suggested locations provided herein are possible locations. It is the responsibility of the purchaser / user to determine the location with the food storage area of the unit that best meets the code requirements above.

The thermometer may need to be moved several times to find the warmest location. Mounting options include flexible plastic for price tag molding application, magnet applied to back of flexible plastic for steel end wall, and double stick tape. Tape must not be exposed after installation.

Questions about either code should be addressed to local agencies or other appropriate officials.

---

**Keep with merchandiser  
or give to store manager.**

# DO NOT DESTROY.

## MAINTENANCE

### CARE AND CLEANING

Long life and satisfactory performance of any equipment is dependent upon the care it receives. To ensure long life, proper sanitation and minimum maintenance costs, these merchandisers should be thoroughly cleaned, all debris removed and the interiors washed down, weekly.

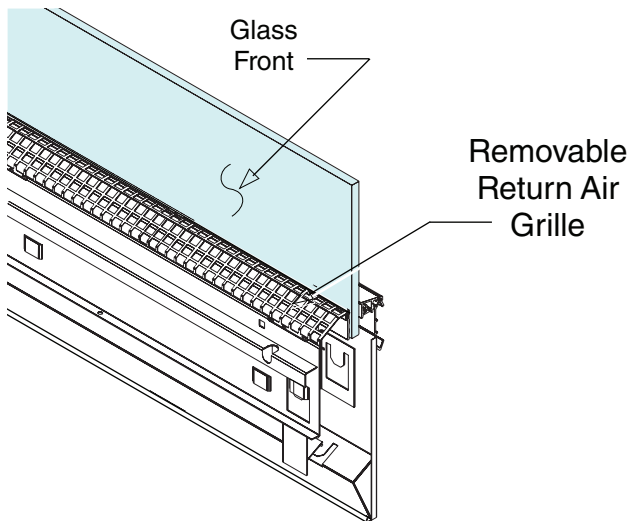
#### Fan Plenum

To facilitate cleaning, the fan plenum is hinged. After cleaning be sure the plenum is properly lowered into position OR PRODUCT LOSS WILL RESULT due to improper refrigeration.



#### Removable Return Air Grille

The return air grille may be removed to facilitate cleaning. Simply lift a four foot section up and out as shown below.



#### Fascia Panels

The fascia panels lift out, left to right, and should be cleaned with a mild detergent and warm water.

**DO NOT USE AMMONIA-BASED PRODUCTS TO CLEAN OPTIONAL ACRYLIC PANELS. NEVER USE ABRASIVE CLEANSERS OR SCOURING PADS.**



### Exterior Surfaces

The exterior surfaces must be cleaned with a mild detergent and warm water to protect and maintain their attractive finish. **NEVER USE ABRASIVE CLEANSERS OR SCOURING PADS.**

### Interior Surfaces

The interior surfaces may be cleaned with most domestic detergents, ammonia based cleaners and sanitizing solutions with no harm to the surface. Always read and follow the manufacturer's instructions when using any cleaning product.



## WARNING

**Do NOT allow cleaning agent or cloth to contact food product.**

### *Do NOT Use:*

- Abrasive cleansers and scouring pads, as these will mar the finish.
- Coarse paper towels on coated glass.
- Ammonia-based cleaners on acrylic parts.
- A hose on lighted shelves or submerge the shelves in water.
- Solvent, oil or acidic based cleaners on any interior surfaces.
- A hose on rail lights, canopy lights or any other electrical connection.

### *Do:*

- **First turn off refrigeration, then disconnect electrical power.**
- Remove the product and all loose debris to avoid clogging the waste outlet.
- Store product in a refrigerated area such as a cooler. Remove only as much product as can be taken to the cooler in a timely manner.
- Thoroughly clean all surfaces with soap and hot water. **DO NOT USE STEAM OR HIGH WATER PRESSURE HOSES TO WASH THE INTERIOR. THESE WILL DESTROY THE MERCHANDISERS' SEALING CAUSING LEAKS AND POOR PERFORMANCE.**
- Lift hinged fan plenum for cleaning. Hook chain in rear panel to secure plenum during cleaning. **BE SURE TO REPOSITION THE FAN PLENUM AFTER CLEANING MERCHANDISER.**
- Take care to minimize direct contact between fan motors and cleaning or rinse water.
- Rinse with hot water, but do NOT flood. **NEVER INTRODUCE WATER FASTER THAN THE WASTE OUTLET CAN REMOVE IT.**
- Allow merchandisers to dry before resuming operation.
- Wipe down lighted shelves with a damp sponge or cloth so that water does not enter the light channel. **DO NOT USE A HOSE OR SUBMERGE SHELVES IN WATER.**
- After cleaning is completed, turn on power to the merchandiser.

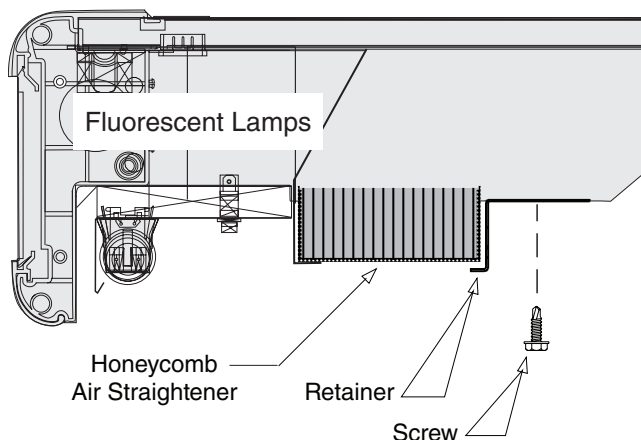
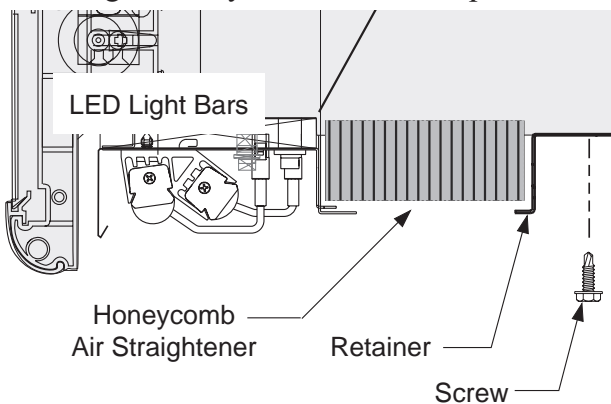
## CLEANING HONEYCOMB ASSEMBLIES

Honeycombs should be cleaned every six months. Dirty honeycombs will cause merchandisers to perform poorly. The honeycombs may be cleaned with a vacuum cleaner. Soap and water may be used if all water is removed from the honeycomb cells before replacing. Be careful not to damage the honeycombs.

### Multi-deck Cases

1. Loosen or remove screw to free honeycomb.
2. Clean and dry the honeycomb.
3. After cleaning, replace honeycomb and slide retainer forward. Reinstall screw.

Damaged honeycomb must be replaced.



## CLEANING ECOVISION II DOORS

Standard glass cleaning solutions may be used to clean the glass surfaces of the merchandiser's EcoVision II doors. Wipe all surfaces dry after cleaning.

- Use only mild cleaning solutions that do not leave residue, such as a weak (10%) solution of vinegar, or isopropyl alcohol and water.
- Never use dirty cloths, scrapers or any other abrasive materials for cleaning.

## CLEANING MIRRORS

Mirrors are sheets of clear glass that have very thin reflective and protective coatings applied to one side. These coatings are susceptible to deterioration if certain cleaning solutions and even water are allowed to come in contact with them. Every precaution should be taken to keep all liquids away from the coated side of the mirrors. IF LIQUIDS ARE ALLOWED TO FLOW ALONG THE FACE SIDE OF THE MIRROR TO ITS EDGE, THE LIQUID CAN SEEP UP BETWEEN THE COATING AND THE GLASS, CAUSING SERIOUS DAMAGE.

### To Help Prolong the Life of the Mirrors:

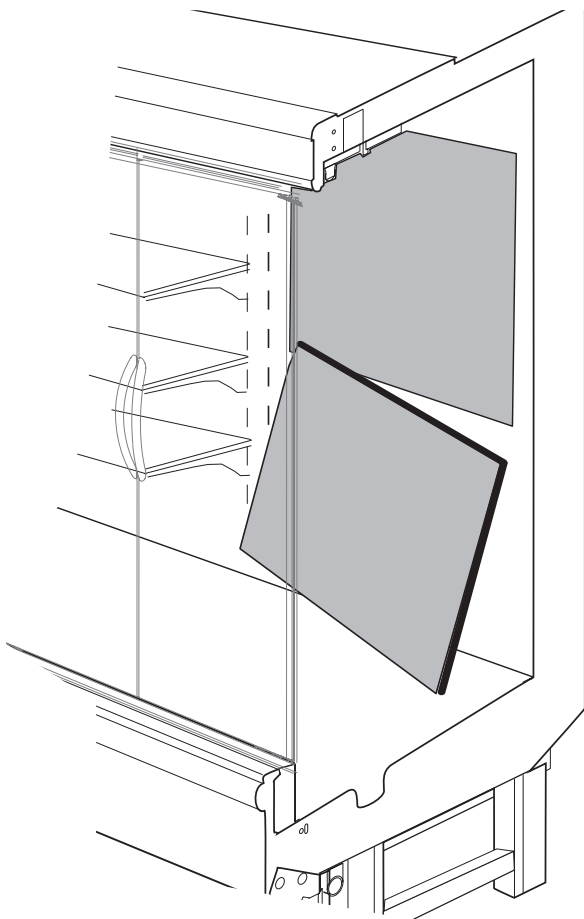
- Use only mild cleaning solutions that do not leave residue, such as a weak (10%) solution of vinegar and water.
- Do NOT spray liquids on the mirrors. Away from food, dampen the cleaning cloth, then use the cloth to wipe the mirror.
- Wipe water from the mirrors immediately to prevent difficult to remove water spots and also to prevent the water from reaching the mirror's edge.
- Never use dirty cloths, scrapers or any other abrasive materials for cleaning.

### CLEANING COILS

**NEVER USE SHARP OBJECTS AROUND COILS.** Use a soft brush or vacuum brush to clean debris from coils. Do not puncture coils! Do not bend fins. Contact an authorized service technician if a coil is punctured, cracked, or otherwise damaged.

ICE in or on the coil indicates the refrigeration and defrost cycle is not operating properly. Contact an authorized service technician to determine the cause of icing, and to make adjustments as necessary. To maintain product integrity, move all product to a cooler until the unit has returned to normal operating temperatures.

**Do NOT use chlorine or ammonia-based cleaners to clean aluminum coils.**



### REMOVING INTERIOR BACK PANELS

The interior back panels may be removed for cleaning and to gain access to the evaporator coils. Remove the rear interior back panels as follows:

1. **DISCONNECT THE ELECTRICAL POWER TO THE MERCHANDISER.**
2. Unplug shelf lights and insert plastic protective cap. Remove shelving.
3. Remove the lower panel
4. Remove the top panel
5. Replace panels in reverse order, starting with the top panel.
6. After cleaning or servicing the merchandiser, allow shelf lights to fully dry. Reconnect shelf lights, and return power to the merchandiser.

## CLEANING STAINLESS STEEL FRONT RAILS

Use non-abrasive tools, and always polish with grain of the steel.

Use alkaline chlorinated or non-chlorine containing cleaners. Do not use cleaners containing salts as this may cause pitting and rusting of the stainless steel finish.

Clean frequently to avoid build-up of hard, stubborn stains. Rinse and wipe dry immediately after cleaning. Never use hydrochloric acid (muratic acid) on stainless steel.

## REMOVING SCRATCHES FROM BUMPER

Most scratches and dings can be removed using the following procedure.

- Use steel wool to smooth out the surface area of the bumper.
- Clean area.
- Apply vinyl or car wax and polish surface for a smooth glossy finish.

## CLEANING UNDER MERCHANDISERS

Remove splashguards not sealed to floor.

Use a vacuum with a long wand attachment to remove accumulated dust and debris from under the merchandiser.

## MAINTAINING FLUORESCENT LAMPS

Fluorescent lamps should not be allowed to run to failure. If a re-lamp schedule is not in place, the tubes should be inspected for signs of degradation (blackened ends). Degraded or failed tubes should be replaced.

Allowing severely degraded lamps to operate may cause a ballast failure or could expose the lamp holder to excessive heat. Replacing degraded bulbs is more cost effective than replacing ballast and lamp-holders.

Traditional re-lamp programs are 18-to-24 month intervals. In the absence of a re-lamp program, a yearly inspection of the lighting system is recommended.

1. Inspect all lamp sockets and plug-receptacle connections for signs of arching. Replace any component that shows signs of arching.
2. Make sure all unused receptacles have their close-off covers securely installed.
3. Make sure proper cleaning procedures are followed. Lights and fans **MUST** be turned off when a case is cleaned and **MUST** be allowed to dry before turning power back on.
4. Do not use a pressure nozzle to clean inside of case.

**5-6 MAINTENANCE**

**NOTES:**

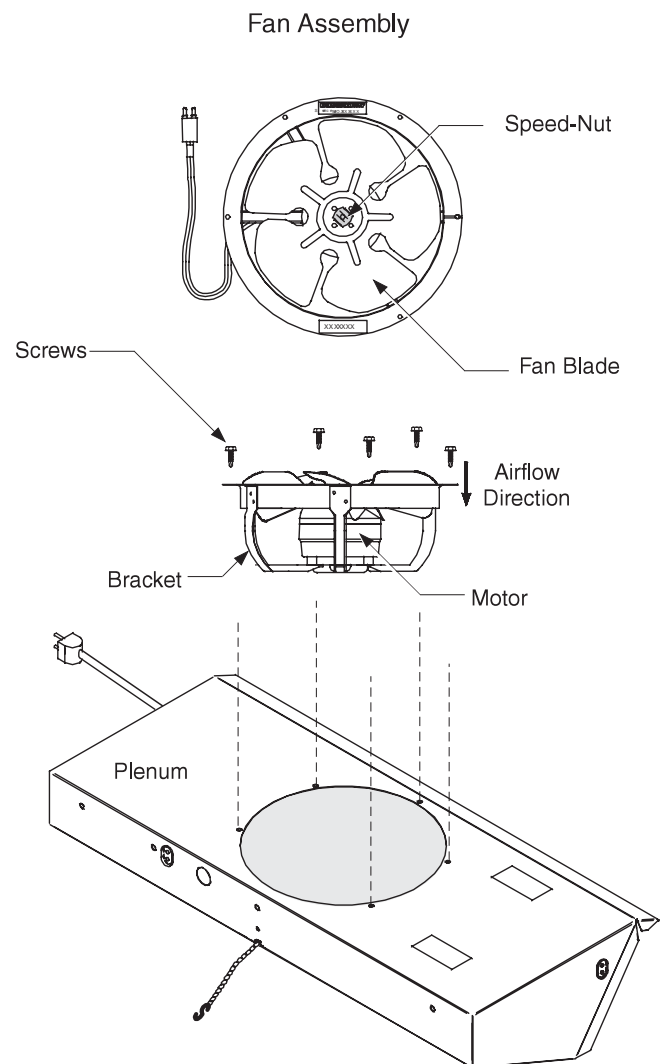
## SERVICE

### REPLACING FAN MOTORS AND BLADES

See cross section for location of evaporator fans. Should it ever be necessary to service or replace the fan motors or blades be certain that the fan blades are re-installed correctly.

For access to these fans:

1. Turn off power.
2. Remove bottom display pans.
3. **Disconnect fan from wiring harness.**
4. Remove fan blade.
5. Remove screws holding fan motor/bracket assembly to plenum and remove assembly.
6. Replace fan motor/bracket assembly and reinstall screws.
7. Reinstall fan blade.
8. Reconnect fan to wiring harness.
9. Turn on power.
10. Verify that motor is working and blade is turning in the correct direction.
11. Close air gaps under fan plenum. Warmer air moving into refrigerated air reduces effective cooling. If the plenum does not rest against the case bottom without gaps, apply foam tape to the bottom of the fan plenum to reduce improper air movement. Use silicone sealant to close other gaps.
12. Replace display pans. Bring merchandiser to operating temperature before restocking.



Medium Temperature Ultra Low Front,  
**Excel with EcoVision II Doors**

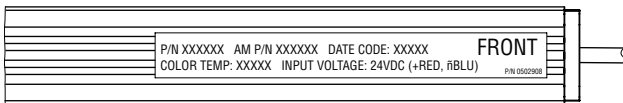
## REPLACING LED CANOPY FIXTURES

LED canopy lights are an available lighting option for EcoVision II doors. They may be ordered with one or two rows.

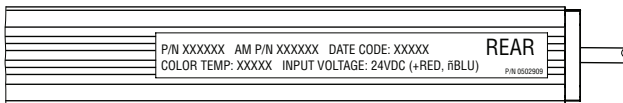
The rear light bar row illuminates the upper section of the case and the front light bar row illuminates the lower section of the case. The front and rear light bars are labeled **FRONT** and **REAR** respectively and have a different shaped lens. They shall not be interchanged.

The light bars are attached to the lamp panel using clips. When replacing clips ensure that the part number of the clip is the same as the original clip. The clips are color coded to simplify identification of the proper clip to be used.

**Front Canopy LED Light Bar**



**Rear Canopy LED Light Bar**

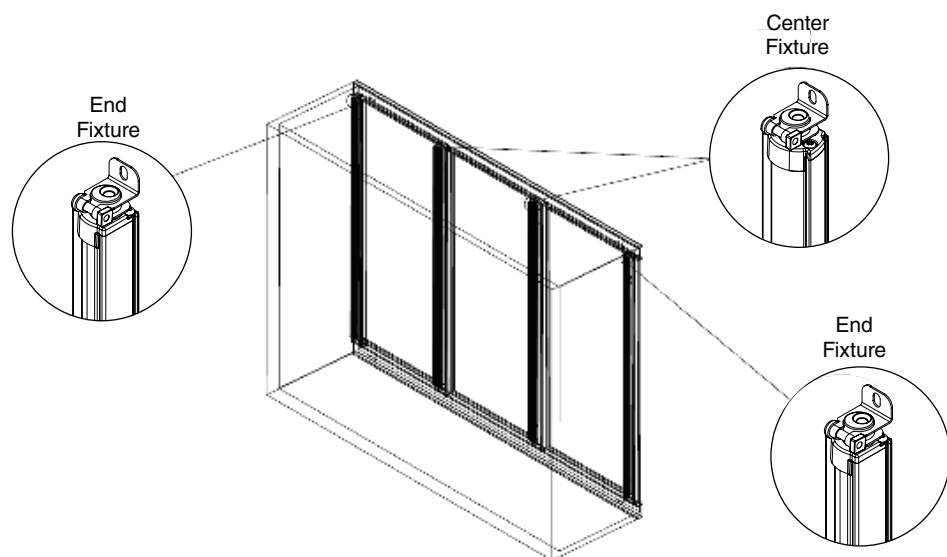


## REPLACING LED VERTICAL MULLION FIXTURES

LED vertical mullion lights are an available lighting option for EcoVision II doors.

Center fixtures illuminate the middle of the case, and the end fixtures illuminate the ends, or sides of the case. These fixtures have different shaped lenses. They are not to be interchanged.

The light bars are attached to the door mullions with mounting clips.



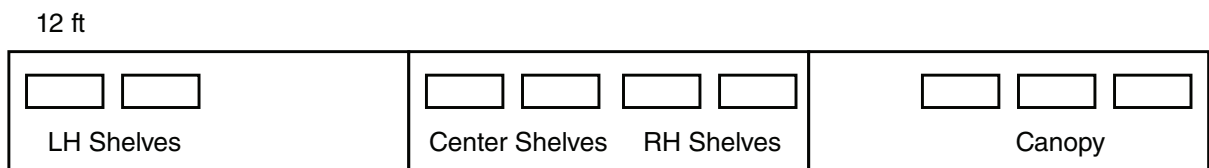
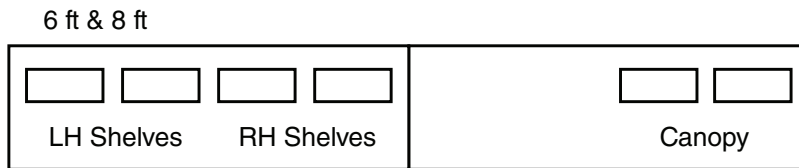
### REPLACING LED POWER SUPPLIES

The LED power supplies for canopy lights are located at the top of the merchandiser inside the canopy.



Power Supply

1. **DISCONNECT POWER TO THE MERCHANDISER.**
2. Remove light bars from the canopy.
3. Remove the screws that secure the lamp panel.
4. Grasp the lamp panel at its front edge and carefully pull down. It will swing freely from its hinged rear edge.
5. Replace power supply and reassemble parts in reverse order.
6. Reconnect the electrical power.



LED Power Supply Locations

Canopy and Shelf LED Power Supply Arrangement

**REPAIRING ALUMINUM COIL**

The aluminum coils used in Hussmann merchandisers may be easily repaired in the field. Materials are available from local refrigeration wholesalers.

Hussmann recommends the following solders and technique:

**Solders**

Aladdin Welding Products Inc.

P.O. Box 7188

1300 Burton St.

Grand Rapids, MI 49507

Phone: 1-800-645-3413

Fax: 1-800-645-3414

X-Ergon

1570 E. Northgate

P.O. Box 2102

Irving, TX 75062

Phone: 1-800-527-9916

**NOTE:**

Hussmann Aluminum melts at 1125°F (607°C)

Aladdin 3-in-1 rod at 732°F (389°C)

X-Ergon Acid core at 455°F (235°C)

**Technique:**

1. Locate Leak.
2. REMOVE ALL PRESSURE.
3. Brush area UNDER HEAT.
4. Use PRESTOLITE TORCH ONLY. Number 6 tip.
5. Maintain separate set of stainless steel brushes and USE ONLY ON ALUMINUM.
6. Tin surface around area.
7. Brush tinned surface UNDER HEAT, thoroughly filling the open pores around leak.
8. Repair leak. Let aluminum melt solder, NOT the torch.
9. Don't repair for looks. Go for thickness.
10. Perform a leak check.
11. Wash with water.
12. Cover with a good flexible sealant.

# **HUSSmann<sup>®</sup>**

To obtain warranty information  
or other support, contact your Hussmann  
representative.

Please include the model and  
serial number of the product.

**Hussmann Corporation**  
12999 St. Charles Rock Road  
Bridgeton, MO 63044-2483  
[www.hussmann.com](http://www.hussmann.com)