

We reserve the right to change or revise specifications and product design in connection with any feature of our products. Such changes do not entitle the buyer to corresponding changes, improvements, additions or replacements for equipment previously sold or shipped.

Item	Part #	Description	Wiring Item #	Item	Part #	Description	Wiring Item #
FAN ASSEMBLIES AND THERMOSTATS				LAMPS AND BALLASTS			
A.	7W Fan Assembly		(1)	D.	0428648	Ballast, Electronic	2 lamps (4)
	0058698	Fan Motor, Evaporator			0428649	Ballast, Electronic	3 lamps
	0142780	Fan Blade embossing toward motor		E.		Fluorescent Lamp	(5)
B.	0398558	Standard Non-adjustable Defrost Thermostat	(2)			<i>Replace with like fixtures</i>	
C.	0144732	Optional Adjustable Refrigeration Thermostat	(3)				

Datasheet-Excel CW2GE

Note: Revision C: Added high glide refrigerant note. Other changes marked by bar, underline or circle.

Engineering Plan Views





PHYSICAL DATA	
Merchandiser Drip Pipe (in.)	1 1/4
Merchandiser Liquid Line (in.)	1/2
Merchandiser Suction Line (in.)	1 1/8

Dimensions shown as inches and (mm).

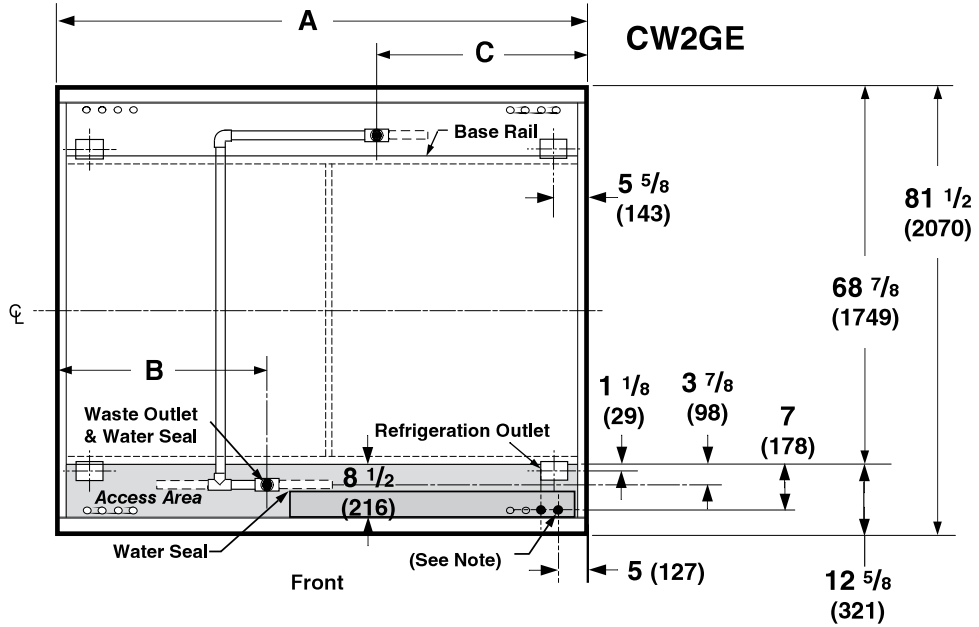
Convertible Island

05-2003



General	4 ft
(A) Case Length (<i>without ends or partitions</i>)	48 1/4 (1226)
Maximum O/S dimension of case back to front (<i>includes bumper</i>)	81 1/2 (2070)
Front of splashguard to O/S edge of front base rail	8 1/2 (216)
Front of case to O/S edge of front base rail	12 5/8 (321)
Back of case to O/S edge of front base rail	68 7/8 (1749)
Width of base rail	2 1/8 (54)
Stub-up area between front base rail and splashguard	7 1/4 (184)
Electrical Service 	
Note: Electrical Field Wiring connection point	
Center of Electrical service to O/S edge of front base rail	7 (178)
Right end of case to center of knockout	5 (127)
Length of electrical wireway	32 5/8 (829)
Waste Outlet 	
(B) LH end of case to the center of waste outlet	38 1/8 (968)
Center of waste outlet to outside of front base rail	3 7/8 (98)
(C) RH end of case to center of rear waste outlet	38 1/8 (968)
Water Seal 	
Water seal length	11 (279)
Schedule 40 PVC drip pipe	1 1/4 (32)
Refrigeration Outlet 	
Center of refrigeration outlet to O/S edge of front base rail	1 1/8 (29)
RH end of case to center of refrigeration outlet	5 5/8 (143)

Impact CW2GE Convertible Island

Dimensions shown as inches and (mm).

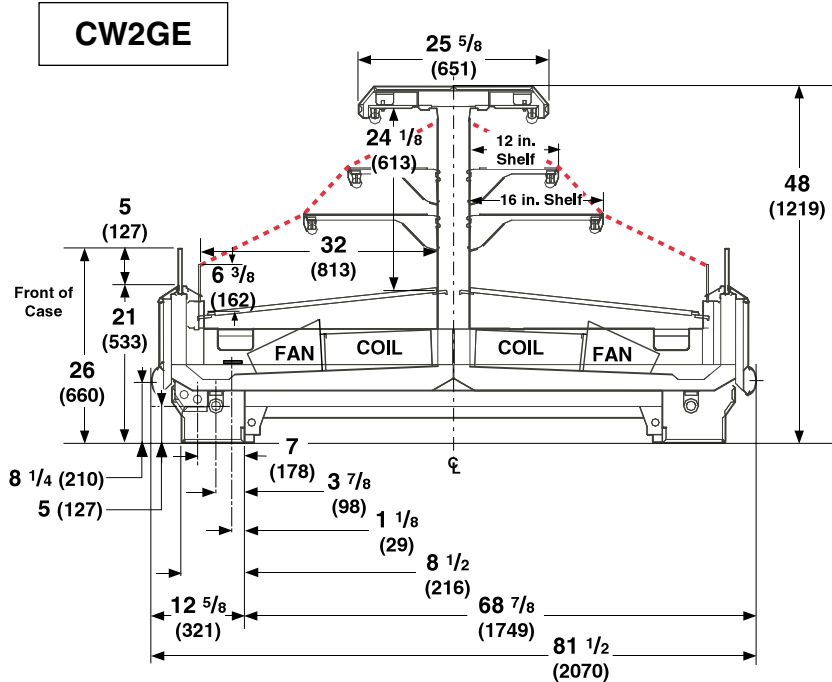

NSF Certification

This merchandiser model is manufactured to meet NSF/ANSI (National Sanitation Foundation) Standard #7 requirements for construction, materials & cleanability.

PHYSICAL DATA

Estimated Charge ****

4 ft 2.3 lb 37 oz 1.0 kg

****This is an average for all refrigerant types. Actual refrigerant charge may vary by approximately half a pound.

Length (in.) added to Lineup by:

Each Flat End or Partition 1 1/2
Each Contoured End 5

REFRIGERATION DATA

Note: This data is based on store temperature and humidity that does not exceed 75°F and 55% R.H.

	CW2GE§
Discharge Air (°F)	28
Avg Evaporator (°F)*	21
Unit Sizing (°F)	19

*For high glide refrigerants, evaporator temperatures listed represent average coil temperature as measured throughout the coil.

§ Average evaporator temperature shown. Use dew point for high glide refrigerants for unit sizing. Care should be taken to use the dew point in PT tables for measuring and adjusting superheat. Adjust evaporator pressure as needed to maintain discharge air temperature shown.

<i>Btu/h/ft</i>	CW2GE
Parallel	1480
Conventional	1640

DEFROST DATA

	CW2GE
Frequency (hr)	6
Defrost Water (lb/ft/day)	10

(± 15% based on case configuration and product loading).

<i>OFF TIME</i>	CW2GE
Temp Term (°F)	48°F
Failsafe (minutes)	45

ELECTRIC OR GAS Not Recommended

Standard Defrost Thermostat

Close on rise: close 48°F — open 33°F

CONVENTIONAL CONTROLS

Low Pressure Backup Control

	CW2GE
C/CO***	17°F / 7°F

Indoor Unit Only, Pressure Defrost

Termination*** 48°F

***Use a Temperature Pressure Chart to determine PSIG conversions.

Impact CW2GE Convertible Island
--

Electrical Data

			4 ft	
Number of Fans—7W			2	
			Amperes	Watts
			4 ft	4 ft
Evaporator Fan				
120V	60Hz	Standard	1.00	78
120V	50Hz	Standard	NA	
230V	60Hz	Export	NA	
230V	50Hz	Export	NA	
120V	60Hz	Energy Efficient	0.38	28
230V	60Hz	Energy Efficient	NA	
Cycling Anti-sweat Heaters			None	
Minimum Circuit Ampacity				
120V	60Hz	Standard	1.20	
120V	50Hz	Standard	NA	
230V	60Hz	Export	NA	
230V	50Hz	Export	NA	
120V	60Hz	Energy Efficient	0.58	
230V	60Hz	Energy Efficient	NA	
Maximum Over Current Protection 120V			20	
Maximum Over Current Protection 230V			15	
208V Electric Defrost Heaters			None	
Standard Lighting (T-8 Fluorescent)				
1 Row Canopy			0.51	59
Optional Lighting (T-8 Fluorescent)				
Additional 1 Row Canopy				
Additional 2 Row Canopy			1.02	118
Optional Shelf Lighting (T-8 Fluorescent)				
1 Rows of Shelves			0.51	59
2 Rows of Shelves			1.02	118

Product Data

Recommended Usable Cube ¹ (Cu Ft/Ft)	6.15 ft ³ /ft (0.57 m ³ /m)
AHRI Total Display Area ² (Sq Ft/Ft)	5.34 ft ² /ft (1.63 m ² /m)
Shelf Area ³ (Sq Ft/Ft)	9.96 ft ² /ft (3.05 m ² /m)

¹ AHRI Refrigerated Volume less shelving and other unusable space: Refrigerated Volume/Unit of Length, ft³/ft [m³/m]

² Computed using AHRI 1200 standard methodology: Total Display Area, ft² [m²]/Unit of Length, ft [m]

³ Shelf surface area is composed of bottom deck plus standard shelf complement, as shown in the Hussmann **Product Reference Guide**. The standard shelf complement for this model is (2) rows of 12-inch shelves and (2) rows of 18-inch shelves.

ESTIMATED SHIPPING WEIGHT⁴

Case	4 ft	Solid End
lb (kg)	700 (318)	(each) 100 (45)

⁴ Actual weights will vary according to optional kits included.

Fan Wiring Offtime Defrost

4 & 6 Fans

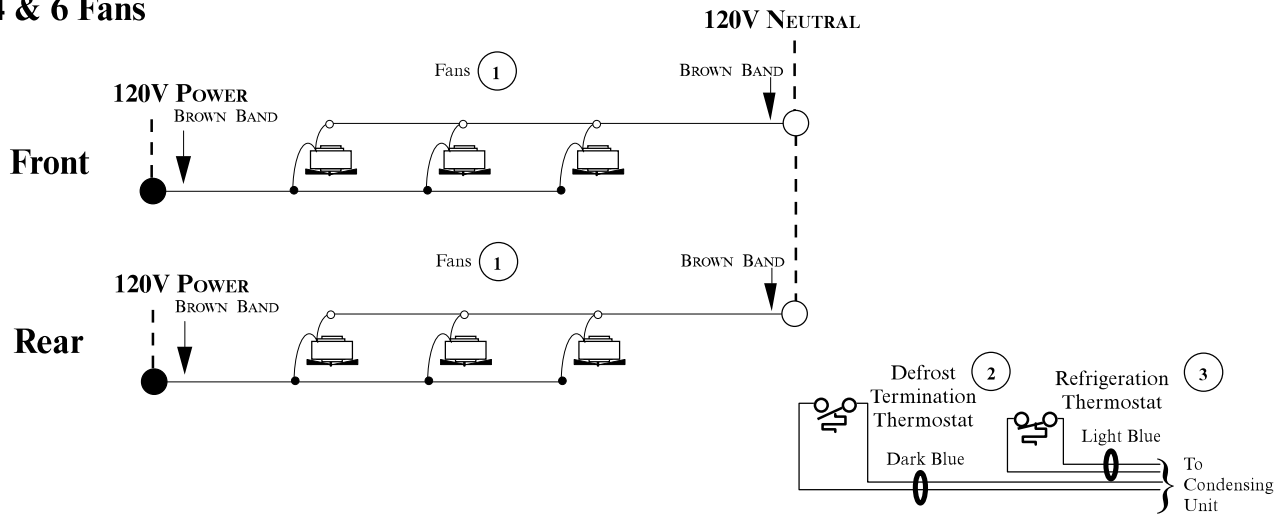

Optional Shelf Lighting

Optional Shelf Harness and Light Circuits for One Row of Shelves

Shelf Harness

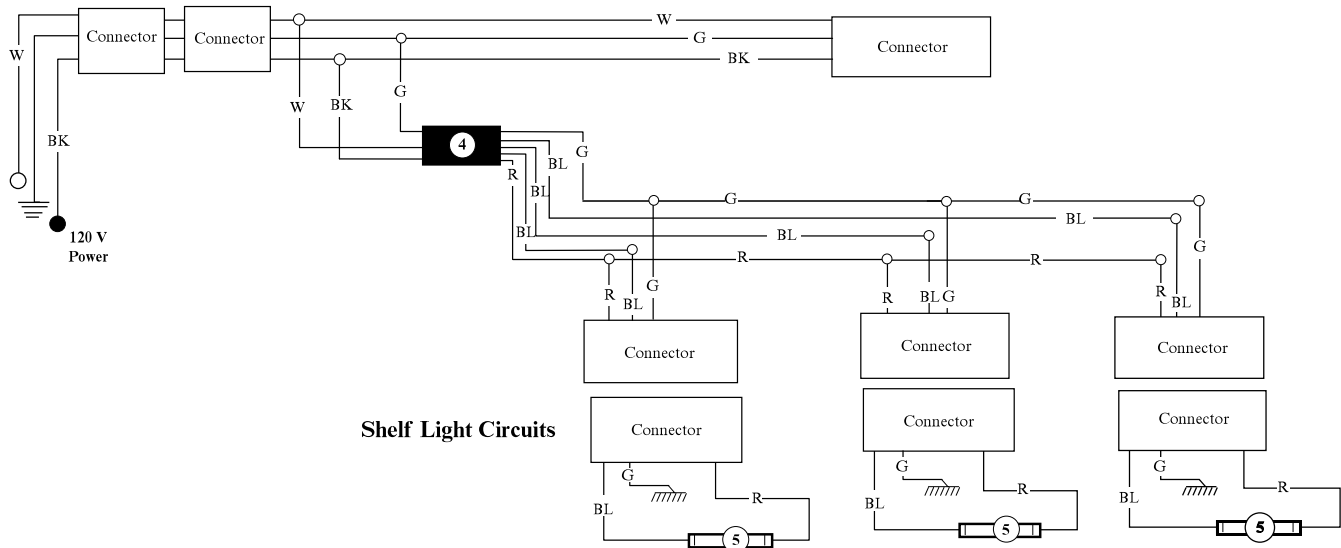

WARNING

All components must have mechanical ground, and the merchandiser must be grounded.

CIRCLED NUMBERS = PARTS LIST ITEM NUMBERS

R = Red Y = Yellow G = Green BL = Blue BK = Black W = White

● = 120V POWER ○ = 120V NEUTRAL ≡ = Field GROUND ≡≡ = Case GROUND

Standard Lighting 1 Row Canopy or Optional 1 Row Rail

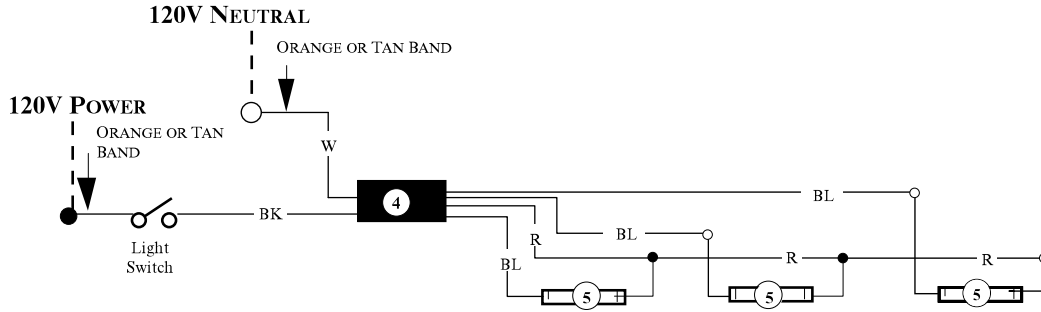

Optional Lighting 2 Rows Canopy

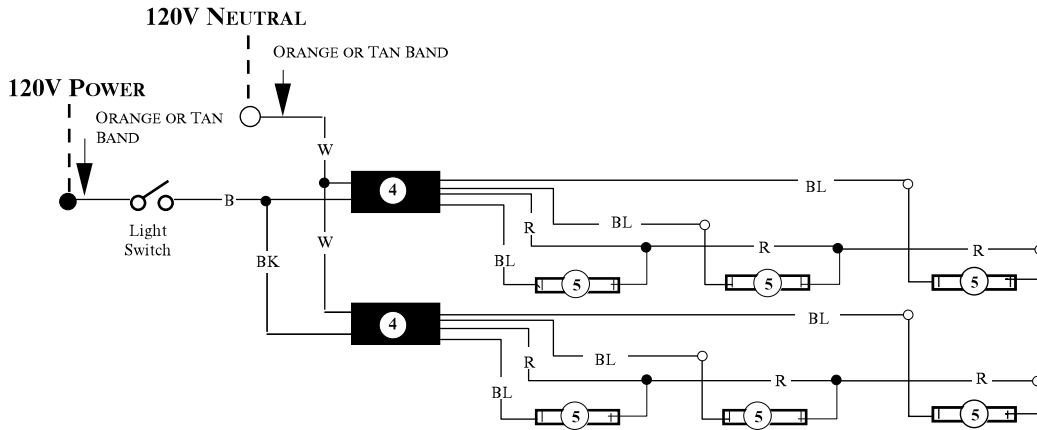

WARNING

All components must have mechanical ground, and the merchandiser must be grounded.

CIRCLED NUMBERS = PARTS LIST ITEM NUMBERS

R = Red Y = Yellow G = Green BL = Blue Bk = Black W = White

● = 120V POWER ○ = 120V NEUTRAL