

HUSSMANN[®]/CHINO
R3HV (CR3HV)-M/F
COMBINATION SERVICE AND SELF-SERVICE MEAT/FISH CASE

Installation
& Operation
Manual

REV. 1123

HUSSMANN[®]

R3HV (CR3HV)-M/F **COMBINATION SERVICE AND SELF-SERVICE MEAT/FISH CASE**



General Instructions

Table of Contents

General Instructions..... 2
Cut and Plan Views 3
Installation..... 4
 Location..... 4
 Uncrating the Stand 4
 Exterior Loading 4
 Leveling 4
 Glass Installation/Balancing 6
 Level Minitop Hardware 6
 R3HV Glass Alignment Field Instructions7
 Joint Trim.....11
 Bumper Installation Instructions11
Plumbing 12
 Waste Outlet and P-TRAP 12
 Installing Condensate Drain 12
Refrigeration 13
 Piping 13
 Refrigeration Lines 13
 Control Settings..... 13
 Access to Thermostatic Expansion Valve (TEX) and Drain Lines..... 13
 Electronic Expansion Valve EEV (Optional) 13
 Thermostatic Expansion Valve Location 13
 Expansion Valve Adjustment 13
 Measuring the Operating Superheat 13
 Evaporator Pressure Regulator..... 13
 Service Case Temperature Control 13
 Thermostat (T-STAT) Location 13
 Specification Sheet 14
Electrical..... 15
 Wiring Color Code 15
 Electrical Circuit Identification 15
 Electrical Service Receptacles (When Applicable)..... 15
 Field Wiring and Serial Plate Amperage 15
 LED Driver Location 15
User Information..... 16
 Stocking 16
 Evaporator Fans..... 16
 Copper Coils 16
 Aluminum Coils 16
 Non-Glare Glass (Optional)..... 16
 Plexiglass and Acrylic Care..... 16
 Cleaning 16
 Antistatic Coatings 16
 Tips and Troubleshooting 16
 Case Cleaning..... 17
 Stainless Steel Cleaning and Care 18
Wiring Diagram Index..... 19
Wiring Diagrams 20
Appendices 26
 Appendix A. - Temperature Guidelines..... 26
 Appendix B. - Application Recommendations 26
 Appendix C. - Field Recommendations..... 26
 Appendix D. - Recommendations to User..... 27

This Booklet Contains Information on:

R3HV-MF: Refrigerated Service Top for Meat with Gravity Coil and Refrigerated Self-Service Front Case

Shipping Damage

All equipment should be thoroughly examined for shipping damage before and during unloading.

This equipment has been carefully inspected at our factory and the carrier has assumed responsibility for safe arrival. If damaged, either apparent or concealed, claim must be made to the carrier.

Apparent Loss or Damage

If there is an *obvious loss or damage*, it must be noted on the freight bill or express receipt and signed by the carrier's agent; otherwise, carrier may refuse claim. The carrier will supply necessary claim forms.

Concealed Loss or Damage

When loss or damage is *not apparent until after equipment is uncrated*, a claim for concealed damage is made. Make request in writing to carrier for inspection within 15 days, and retain all packaging. The carrier will supply inspection report and required claim forms.

Shortages

Check your shipment for any possible shortages of material. If a shortage should exist and is found to be the responsibility of Hussmann Chino, *notify Hussmann Chino*. If such a shortage involves the carrier, *notify the carrier immediately*, and request an inspection. Hussmann Chino will acknowledge shortages within ten days from receipt of equipment.

Hussmann Chino Product Control

The serial number and shipping date of all equipment has been recorded in Hussmann's files for warranty and replacement part purposes. All correspondence pertaining to warranty or parts ordering must include the serial number of each piece of equipment involved, in order to provide the customer with the correct parts.



**ATTENTION
INSTALLER**

This equipment is to be installed to comply with the applicable NEC, Federal, State, and Local Plumbing and Construction Code having jurisdiction.

Keep this booklet with the case at all times for future reference.

HUSSMANN®/CHINO

A publication of HUSSMANN® Chino
13770 Ramona Avenue • Chino, California 91710
(909) 628-8942 FAX
(909) 590-4910
(800) 395-9229

Cut and Plan Views

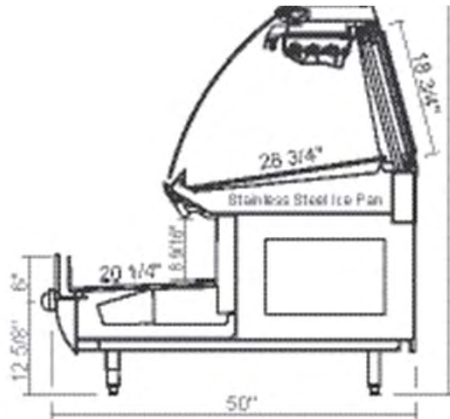

CR3HV-F
High Volume Fish Case with Curved Glass,
Gravity Coil and Ice Pans
Scale = 1/2"

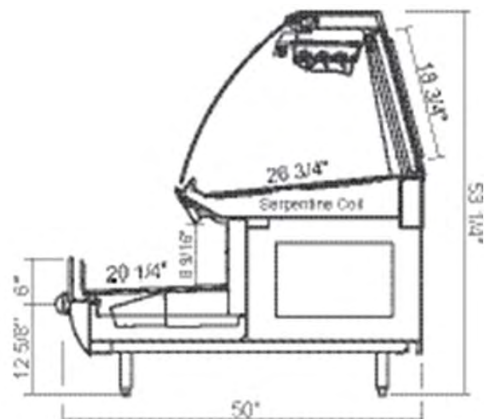

CR3HV-M
High Volume Meat Case with Curved Glass,
Gravity and Conduction Coil
Scale = 1/2"

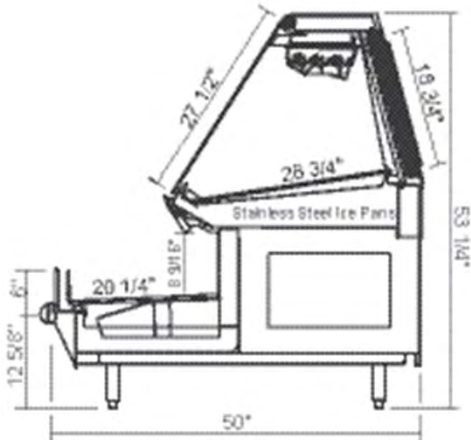

R3HV-F
High Volume Service - Fish Case with
Straight Glass, Gravity Coil and Ice Pans
Scale = 1/2"

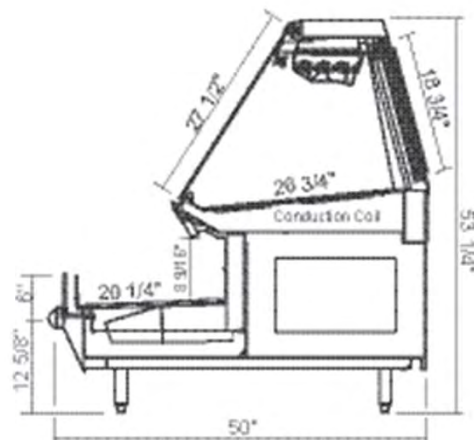

R3HV-M
High Volume Meat Case with Straight Glass,
Gravity and Conduction Coil
Scale = 1/2"

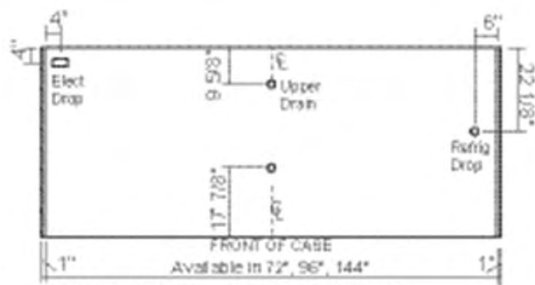

FRONT OF CASE
Available in 72", 96", 144"
R3HV CR3HV R3HV-F CR3HV-F
R3HV-M CR3HV-M
Service Cases with Self Service Front
Plan View
Scale = 1/4"

Installation



INFORMATION

Please read these instructions completely before beginning case installation

Location

The refrigerated merchandisers have been designed for use only in air conditioned stores where temperature and humidity are maintained at or below 75°F and 55% relative humidity. **DO NOT** allow air conditioning, electric fans, ovens, open doors or windows (etc.) to create air currents around the merchandiser, as this will impair its correct operation.

Product temperature should always be maintained at a constant and proper temperature. This means that from the time the product is received, through storage, preparation and display, the temperature of the product must be controlled to maximize life of the product.

Uncrating the Stand

Place the fixture as close to its permanent position as possible. Remove the top of the crate. Detach the walls from each other and remove from the skid. Unbolt the case from the skid. The fixture can now be lifted off the crate skid. **Lift only at base of stand!**

Exterior Loading

These models have **not** been structurally designed to support excessive external loading. **Do not walk on their tops;** This could cause serious personal injury and damage to the fixture.

Leveling

IMPORTANT!: TO AVOID REMOVING CONCRETE FLOORING, WHEN INSTALLING A LINEUP OF CASES, IT IS IMPERATIVE THAT THE HIGHEST SPOT OF THE STORE FLOOR IN THE AREA WHERE THE CASES ARE TO BE SET IS DETERMINED. BEGIN SETTING THE LINEUP WITH THE CASE THAT IS NEAREST TO THE HIGHEST PART OF THE FLOOR. IF A WEDGE IS A PART OF THE LINEUP NEAR THE HIGH SPOT, SET IT FIRST.

IMPORTANT!: WHEN REMOVING LOOSE PARTS FROM INSIDE OR ON TOP OF THE CASE SUCH AS INSTALLATION KITS, HARDWARE OR FASTENERS, ICE PANS, DISPLAY PANS, SPLASH GUARDS, AND INSTRUCTION MANUALS TO GAIN ACCESS TO THE SIDE BULKHEADS AT EACH END OF THE CASE OR TO BEGIN PREPARATION FOR INSTALLATION: DO NOT LOSE THEM OR PUT THEM WHERE THEY CAN BECOME DAMAGED.

LEVELING: ALL CASES WERE LEVELED AND JOINED WHERE NECESSARY PRIOR TO SHIPMENT TO ENSURE THE CLOSEST POSSIBLE FIT WHEN CASES ARE JOINED IN THE FIELD. WHEN JOINING, USE A CARPENTERS LEVEL AND SHIM LEGS ACCORDINGLY. CASES MUST BE RAISED CORRECTLY: LIFT UNDER LEGS OR WOOD LEG BRACES WHERE SUPPORT IS BEST, TO PREVENT DAMAGE TO THE CASE.

1. It is imperative that the cases be leveled from front to back and side to side as they are being joined beginning with the first case that is set in place. Remember: the first case in a line-up to be set should be the one closest to the highest spot of the store floor. A level case is necessary to ensure proper operation, water drainage, and glass alignment. Remove any skids or shipping supports that are **under** the legs. Leave the leg supports attached to the sides of the legs on the case until the case has been set and leveled.

Front to back plumb should be checked by placing the level on the top of the side bulkhead of the lower case after the lower deck pans have been removed. Make sure that the area on the bulkhead where the level is placed is smooth and free of debris. Check plumb at both ends of the case at the side bulkheads.

Side to side plumb should be checked both at the front and rear of the case. At the front, a level can be placed on the stainless steel liner cap at the front of the lower case interior or on the stainless steel bumper box between the bumper and front Plexiglass. At the rear of the case, place the level on the stainless steel rear ledge. **Check plumb at the center and ends** to ensure that the case is truly level and that **all** legs of the case are supporting the weight of the case equally, front and rear and side to side.

2. Set the first case, and adjust the legs over the highest part of the floor so that case is level as described above. Prevent case damage: if lifting the case, it must be raised under the legs, the leg tubes or by the use of the wood 2" x 6" or 2" x 4" leg braces if applicable. Remove the side and back leg braces **after** the case is set.
3. Set the second case as close as possible to the first case, and level the second case to the first using the instructions in step 1. This will be a mock-up only. The final leveling of the case will be rechecked once they are bolted together in steps 7 and 8.
4. Apply masking tape 1/8" in from end of case on the inside and outside rear mullion and to the side bulkheads on both cases to be joined. The tape will minimize cleanup from sealant overflow when the cases are drawn together. (It can also be left in place on the upper case mullions and exterior bodywork for finish caulking with silicone in step 9.)

Installation (Cont'd)

- 5. Apply liberal beads of case joint sealant (butyl) to the areas (solid dark lines) shown in the diagram below (Fig.2, #1) of the first case.

DO NOT USE PLUMBER'S PUTTY!

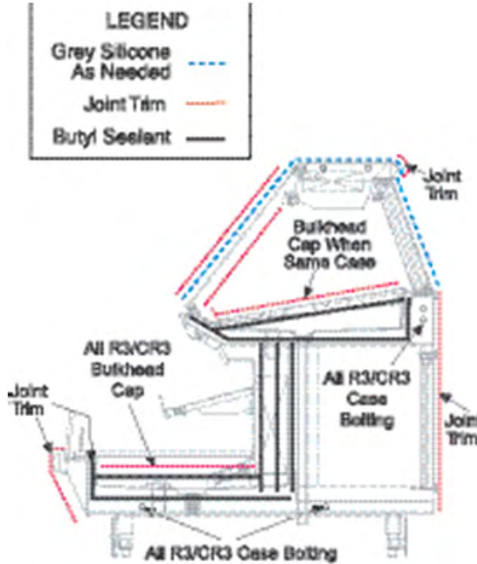



Fig.2, #1

DO NOT USE PLUMBER'S PUTTY!

Plumber's putty will not allow the cases to be fully drawn together which will cause gaps between the cases resulting in poor bodywork fit, finish and case sealing. Only use Plumber's putty where necessary after the cases have been bolted and drawn tightly together.



ATTENTION INSTALLER

This equipment is to be installed to comply with the applicable NEC, Federal, State, and Local Plumbing and Construction Code having jurisdiction.

- 6. Slide the second case up to the first case snugly. Then align the second case to the first case so that the glass, front bumper, bodywork, and top are flush.

- 7. To compress the sealant at the joints, use two Jurgenson® or similar hand screw type wood clamps. Make sure the case is level from front to back and side to side per the instructions in step 1. If using clamps on the plastic sprayed interior liner use scrap wood (as wide as possible) under the clamps so that the liner is not damaged. Be careful to observe the area where the clamp is being tightened so that the case is not damaged as pressure is applied.
- 8. Attach cases together via 2 bolts located in the end leg tubes at the base of the cases and 1 bolt in the rear raceway end brackets. On fixed glass Meat and Fish cases, there are 2 additional bolts in the top of the case that are accessible by removing the top insert. The top insert is removed by pushing up on the bottom side of the insert from inside of the case.
- 9. Remove the masking tape from the bulkheads only and trial fit the stainless steel bulkhead caps. Once proper fit is confirmed, apply a bead of silicone to the tops of the bulkheads and install the stainless steel bulkhead cap. Also, sparingly apply silicone to seal case interior and exterior bodywork as needed to ensure a water-tight seal, and a cleanable and professional appearance. Use a finger in a clean rag, as you go, to smooth the silicone as thin as possible on the inside and outside of the case, while it is still fluid. (Apply additional silicone if necessary). Immediately remove the masking tape applied in step 3.



DANGER

GLASS BREAKAGE MAY OCCUR!
Retighten glass along glass clamp after leveling and first time case is brought to full operating temperature!

Installation (Cont'd)

Glass Installation/Balancing

Glass Adjustment

The top cylinders, which allow the raising and lowering of the glass, have been carefully tested for proper tension. However, during shipment, the lubricant inside may have settled. This settling may cause excessive or uneven tension on the glass - to the point of breakage. Perform the three easy steps listed below before completely raising the front glass.

1. Slowly raise and lower each glass section 6 times to a height of 6 inches.
2. Increase the height to 12 inches, and raise and lower the glass 6 more times.
3. Finally raise the glass to its full extension, and lower.

These steps should release any settled lubricant within the cylinders and prevent any stress on the front glass.

Additionally, after installing NEW cylinders, it is advisable to perform these three easy steps before completely raising the front glass.



CYLINDERS ARE A "WEAR" ITEM
Glass is HEAVY and can cause bodily harm.
Cylinders are designed to:

- Support the glass when fully open
- Allow the glass to close slowly

Have your Service Contractor replace the cylinders when required.

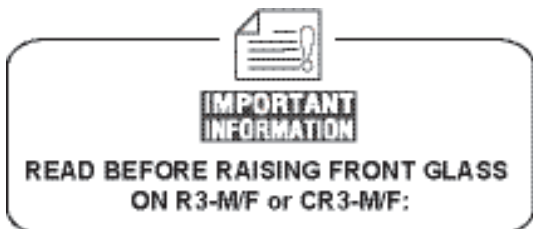

Level Minitop Hardware IF GLASS DOES NOT CLOSE/STAY OPEN PROPERLY - Level MINI TOP HARDWARE

During shipping, it is possible that the mini top hardware housing the pistons and armature has been jostled out of position. This affects the opening angle of the glass.

1. Be sure mini top hardware is level front to back by placing a level along the top of the mini top housing at each hinge location. **If it is not, you will need a shim kit before you can correct. Order from Hussmann.**
2. Remove top glass and panel at top of hardware housing.
3. Mark position of hardware (glass) in relation to case before loosening hex screw using masking tape applied on mini top hardware and case, and pen. Hex screw allows realignment of glass angle and position front to back.
4. Raise glass and loosen hex screw. (See diagram on page 9.)
5. Shim to adjust until level using shims available from Hussmann (16 or 20 gauge stainless steel).
6. Check angle by using level placed on top of mini top hardware. Note: a 6" level will fit perfectly within access area.
7. Tighten hex screw.
8. If there is still a problem with glass staying open over-level by adding an addition shim under front of case.

NOTE: Before making any of the recommended adjustments, Verify that the case(s) have been leveled properly.

Installation (Cont'd)

R3HV Glass Alignment Field Instructions

These field instructions have been developed to help resolve a glass alignment issue with R3HV cases in the field.

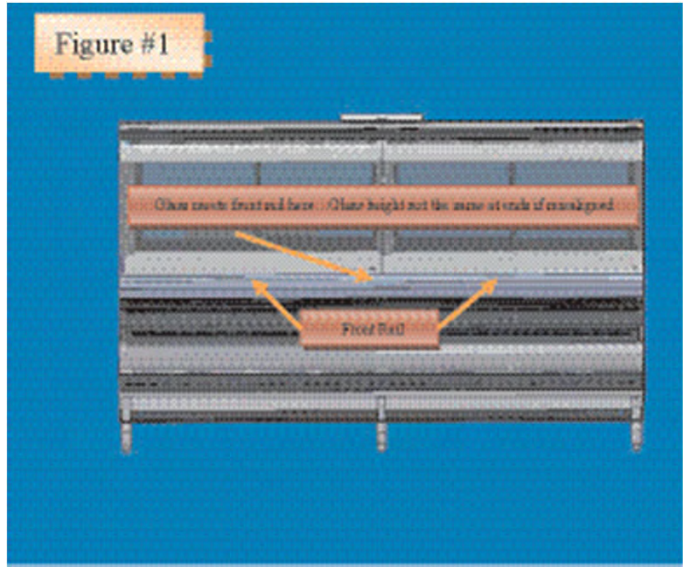

Figure #1 will show how the glass should be level when touching the front rail of the case in the middle section. If glass is misaligned then on the end of the case, where it meets the front rail, the glass could be higher.

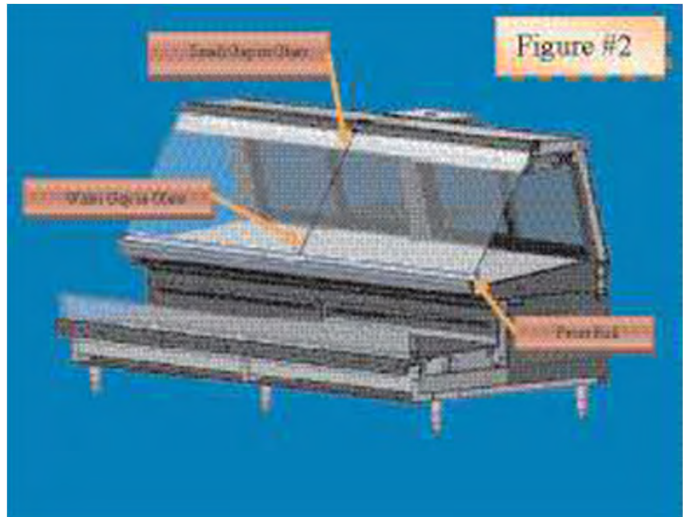

Figure #2 will show how, if there is misalignment the upper section of the glass, there will be a smaller gap than the lower section.

This will also lead to the outward ends of the glass being higher as referenced above.

Installation (Cont'd)

The following is the sequence of steps that should be taken to correct glass misalignment issues; Step 1

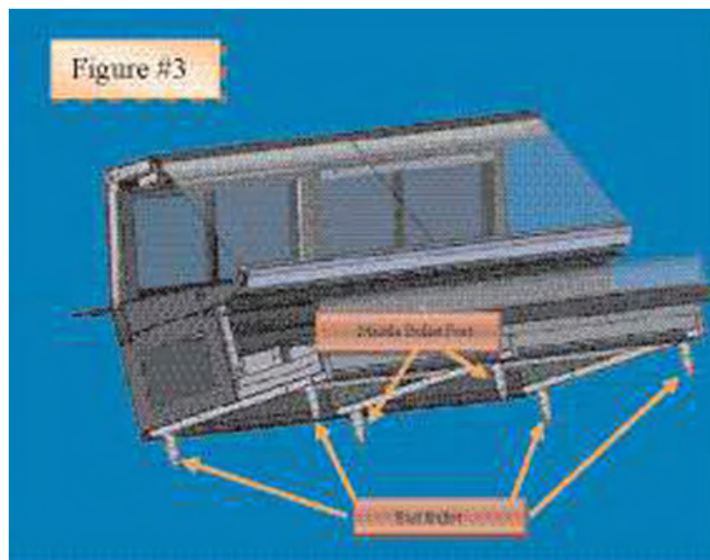

Figure #3 will show Step 1 procedures.

- Always check to see if case has been leveled properly
- Ensure that the middle case bullet feet are touching the floor
- Case load is distributed evenly across all case bullet feet

Step 2

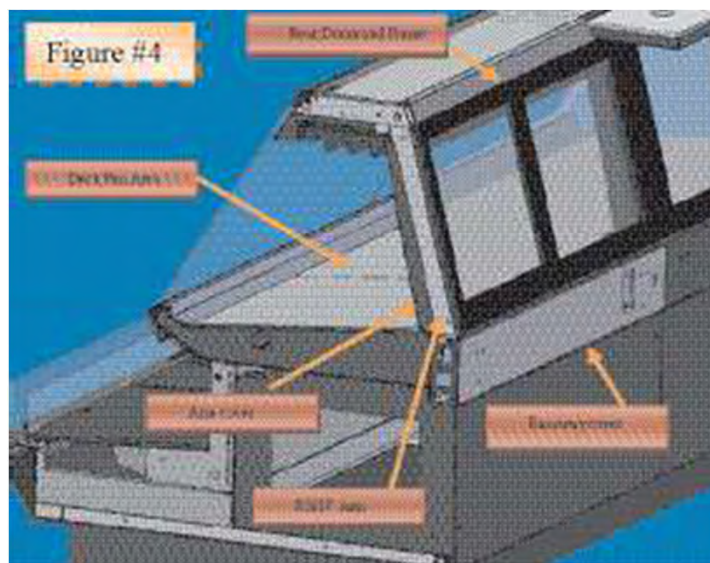

Figure #4 will show Step 2 procedures.

- Remove electrical raceway cover by removing screws
- From inside of the case lift and remove pans
- Remove arm covers by taking out rear door and frame then cut away silicone

Installation (Cont'd)

Step 3

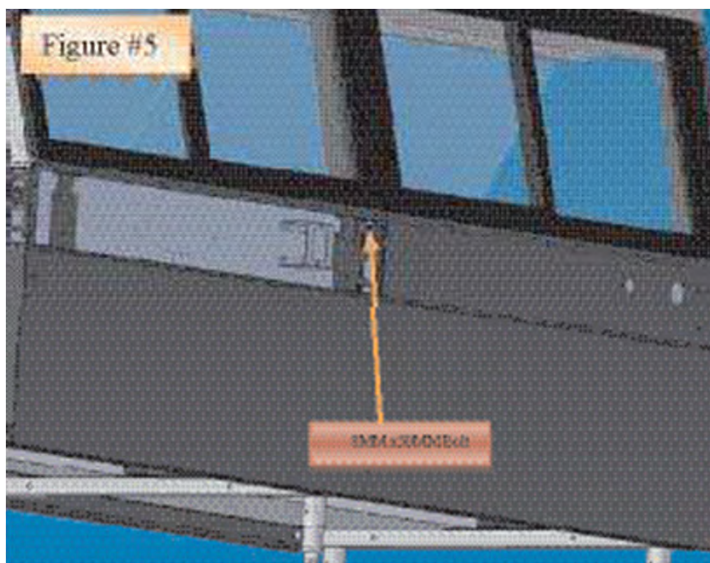

Figure #5 will show Step 3 procedures.

- Loosen bolt in raceway to allow arm freedom to move
- Bolt size is 8mm x 50mm

Step 4

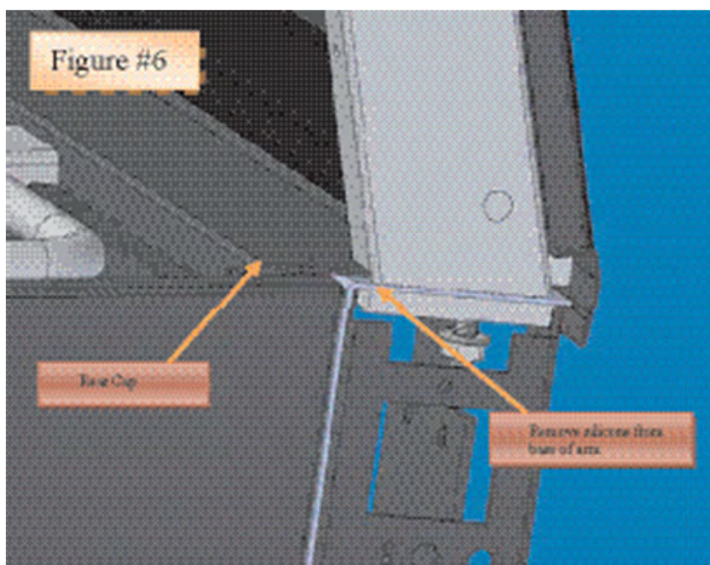

Figure #6 will show Step 4 procedures.

- Remove rear cap from rear of case
- Cut out silicone to gain access to base of arm
- ❖ **DEPENDING ON THE DEGREE OF MISALIGNMENT IT MAY BE NECESSARY TO LOOSEN THE STRUTS ON EITHER SIDE OF THE GAP**

Installation (Cont'd)

Step 5

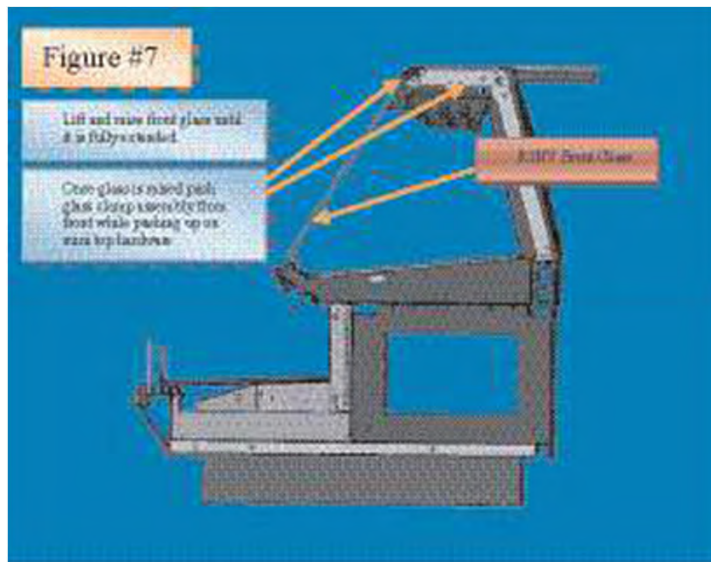

Figure #7 will show Step 5 procedures.

- ❖ BEFORE BEGINNING NEXT STEP ENSURE THERE ARE TWO PEOPLE AVAILABLE TO DO WORK
- Lift front glass and open until glass is at full extension
- Once glass is fully extended gently push the glass clamp assembly
- At the same time push up on mini top hardware to raise case arms

Step 6

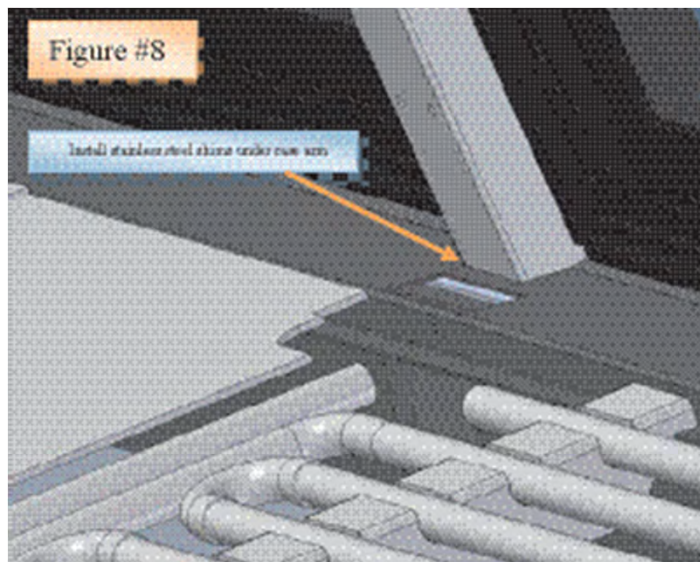

Figure #7 will show Step 6 procedures.

- Insert stainless steel shims in the gap created
- Once done check glass alignment for correct position
- Once done tighten bolts in rear raceway on case arms
- Re-install arm cover and apply silicone sealer
- Re-install deck pans
- Re-install rear raceway cover

Installation (Cont'd)

Joint Trim

After cases have been leveled and joined, and refrigeration, electrical, and waste piping work completed, install the splashguards and joint trim where necessary. Fasten the splash guards along the top edge, or center, with 3/8" long sheet metal screws. If needed, use silicone sparingly to caulk the joint trim and exterior body panels with an appropriate colored silicone to ensure that a cleanable and professional appearance is achieved. Use a finger in a clean rag, as you go, to create smooth and neat joints, while the silicone is still fluid.

DO NOT SEAL JOINT TRIM OR SPLASHGUARDS TO THE FLOOR!

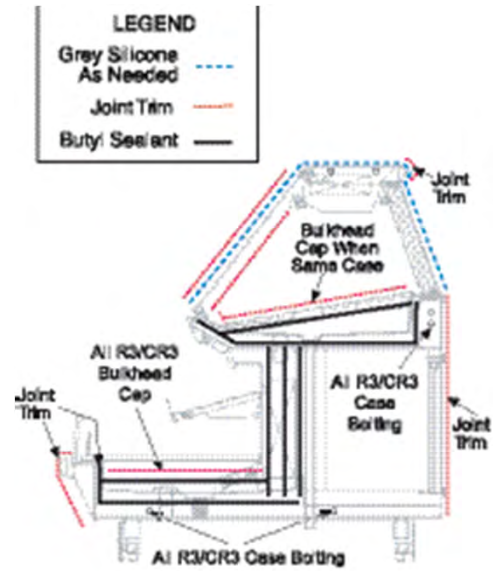

Bumper Installation Instructions



Step 1: Make sure the aluminum channel and end caps are installed.



Step 2: Use silicone lubricant to help the bumper slide into the channel.



Step 3: Starting on one end: while inserting the bumper, push it up against the end cap to prevent the bumper from shrinking after installation (when it gets cold).



Step 4: As you insert the bumper into the channel with one hand, pull the bumper toward you with the other to open the inside lips. Slowly apply pressure by rolling the bumper into the track.

Plumbing

Waste Outlet and P-TRAP

The waste outlet is located off the center of the case on one side allowing drip piping to be run lengthwise under the fixture. There are 2 drains in each fixture that can be easily located.

P-traps must be installed at the base of all refrigerated cases. The 1 ½" P-TRAP and threaded adapter must be installed to prevent air leakage and insect entrance into the fixture.

Installing Condensate Drain

Poorly or improperly installed condensate drains can seriously interfere with the operation of this refrigerator, and result in costly maintenance and product losses. Please follow the recommendations listed below when installing condensate drains to insure a proper installation:

1. Never use pipe for condensate drains smaller than the nominal diameter of the pipe or P-TRAP supplied with the case.
2. When connecting condensate drains, the P-TRAP must be used as part of the condensate drain to prevent air leakage or insect entrance. Store plumbing system floor drains should be at least 14" off the center of the case to allow use of the P-TRAP pipe section. Never use two water seals in series in any one line. Double P-TRAPS in series will cause a lock and prevent draining.

3. Always provide as much down hill slope ("fall") as possible; 1/8" per foot is the preferred minimum. PVC pipe, when used, must be supported to maintain the 1/8" pitch and to prevent wrapping.
4. Avoid long runs of condensate drains. Long runs make it impossible to provide the "fall" necessary for good drainage.
5. Provide a suitable air break between the flood rim of the floor drain and outlet of condensate drain. 1" is ideal.
6. Prevent condensate drains from freezing:
 - a. Do not install condensate drains in contact with non-insulated suction lines. Suction lines should be insulated with a non absorbent insulation material such as Armstrong's Armaflex.
 - b. Where condensate drains are located in dead air spaces (between refrigerators or between a refrigerator and a wall), provide means to prevent freezing. The water seal should be insulated to prevent condensation.

WARNING!
Do NOT apply thread sealer to ABS P-Trap.



Refrigeration

Piping

The refrigerant line outlets are located under the case. Locate first the electrical box, the outlets are then on the same side of the case but at the opposite end. Insulate suction lines to prevent condensation drippage.

Refrigeration Lines

Liquid	Suction
3/8" O.D.	5/8" O.D.

NOTE: The standard coil is piped at 5/8" (suction); however, the store tie-in may vary depending on the number of coils and the draw the case has. Depending on the case setup, the connecting point in the store may be 5/8", 7/8", or 1 1/8". Refer to the particular case you are hooking up.

Refrigerant lines should be sized as shown on the refrigeration legend furnished by the store.

Oil traps must be installed at the base of all suction line vertical risers on refrigerated cases.

Pressure drop can rob the system of capacity. To keep the pressure drop to a minimum, keep refrigerant line run as short as possible, using the minimum number of elbows. Where elbows are required, use long radius elbows only.

Control Settings

See R3(CR3)-M/F technical data sheet for the appropriate settings for your merchandiser. Maintain these parameters to achieve near constant product temperatures. Product temperature should be measured first thing in the morning, after having been refrigerated overnight. Defrost times should be as follows: OFF CYCLE - Defrost times should be as directed in the R3HV (CR3HV)-M/F technical data sheet. The number of defrosts per day and the duration of the defrost cycle may be adjusted to meet conditions present at your location.

Access to Thermostatic Expansion Valve (TEX) and Drain Lines

Mechanical - Remove product from end of case. Remove product racks. Remove refrigeration and drain access panels (labeled). TEX valve (mechanical only) and drain are located under each access panel at end of the case.

Electronic - The Electronic Expansion valve master and slave cylinder(s) are located within the electrical access panel(s).

Electronic Expansion Valve EEV (Optional)

A wide variety of electronic expansion valves and case controllers can be utilized. Please refer to EEV and controller manufacturers information sheet. Sensors for electronic expansion valves will be installed on the coil inlet, coil outlet, and in the discharge air. (Some supermarkets require a 4th sensor in the return air). Case controllers will be located in the electrical raceway or under the case.

Thermostatic Expansion Valve Location

This device is located on the same side as the refrigeration stub. A balanced port expansion valve model is furnished as standard equipment, unless otherwise specified by customer.

Expansion Valve Adjustment

Expansion valves must be adjusted to fully feed the evaporator. Before attempting any adjustments, make sure the evaporator is either clear or very lightly covered with frost, and that the fixture is within 10°F of its expected operating temperature.

Measuring the Operating Superheat

1. Determine the suction pressure with an accurate pressure gauge at the evaporator outlet.
2. From a refrigerant pressure temperature chart, determine the saturation temperature at the observed suction pressure.
3. Measure the temperature of the suction gas at the thermostatic remote bulb location.
4. Subtract the saturation temperature obtained in step No. 2 from the temperature measured in step No. 3. The difference is superheat.
5. Set the superheat for 5°F - 7°F.

Evaporator Pressure Regulator

An Evaporator Pressure Regulator is installed in the front of the self service section to maintain a constant discharge temperature. It is located at the front right side of the case, under the fan plenum near the TEX Valve.

Service Case Temperature Control

Temperature control in the upper section of the CR3 with the Service Option is done by means of a thermostat and suction solenoid valve. This controls both temperature and humidity.

Thermostat (T-STAT) Location

Thermostats are located within the electrical raceway. Refer to diagram below. There are also labels on the back of the case indicating T-STAT location(s).

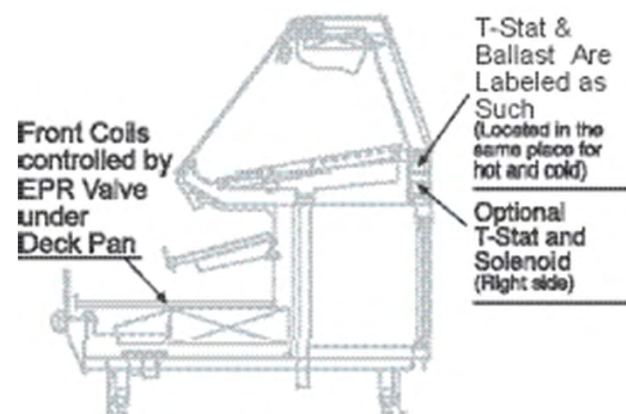

Figure #3

Specification Sheet



DELI SERVICE - SELF SERVICE
HUSSMANN - R3HV-M, CR3HV-M, R3HV-F, CR3HV-F (CHINO)

REVISION DATE 01/11/16

DOE 2017 Energy Efficiency Compliant
 Hussmann refrigerated merchandisers configured for sale for use in the United States meet or surpass the requirements of the DOE 2017 energy efficiency standards.

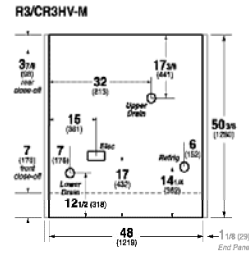
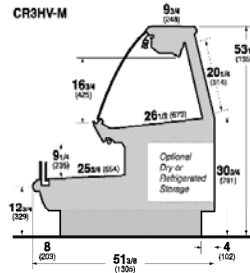
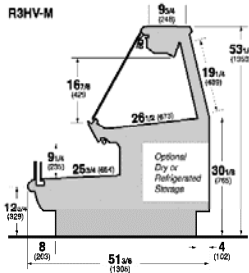
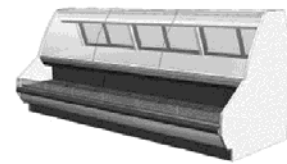

REFRIGERATION DATA:

CASE LENGTHS/ WEDGES	CASE USAGE	CAPACITY TOP/FRONT *** (BTU/HR/FT)		TEMPERATURE (°F)			VELOCITY (TOP/FRONT) (FT/MIN)
		RATING CONDITION		EVAPORATOR (TOP/FRONT)		DISCHARGE AIR (TOP/FRONT**)	
		NSF 7	AHRI 1200	NSF 7	AHRI 1200	NSF 7	
4', 6', 8', 12'	MEAT / FISH	260/740	120/335	20/20	24/24	26 / 30	50~75 / 175~200
REAR STORAGE	MEAT / FISH	110	90	20	26	32~34	380~600

CASE LENGTHS	EST. REFG. CHRGS. (R404A) (LBS)	20°F GLYCOL 6° RISE INLET TOP		20°F GLYCOL 6° RISE INLET FRONT		20° GLYCOL 6° RISE INLET OPTION REFRIGERATED REAR STORAGE	
		GPM	PSI	GPM	PSI	GPM	PSI
4'	1.8	0.4	0.7	1.1	2.7	0.2	0.1
6'	2.6	0.5	2.0	1.5	6.2	0.2	0.3
8'	3.5	0.7	3.7	2.0	2.9	0.3	0.5
12'	5.2	1.0	8.7	3.0	5.8	0.5	1.1

**FRONT DISCHARGE AIR MEASURED INSIDE AIR CURTAIN HONEYCOMB

***REFRIGERATION NOTES:

- 1) BTUS INCLUDE 2 ROWS (1 TOP; 1 FRONT) CANOPY LED LIGHTS AND NO SHELF LIGHTS
- 2) ADD 10 BTUS PER FOOT/PER SHELF FOR OPTIONAL LED SHELF LIGHTS
- 3) AHRI 1200 RATING POINT FOR ENERGY CONSUMPTION COMPARISON ONLY
- 4) USE DEW POINT FOR HIGH GLIDE REFRIGERANTS. CARE SHOULD BE TAKEN TO USE THE DEW POINT IN P/T TABLES FOR MEASURING AND ADJUSTING SUPERHEAT. ADJUST EVAPORATOR PRESSURE AS NEEDED TO MAINTAIN THE DISCHARGE AIR TEMPERATURE SHOWN.
- 5) THE PRINCIPAL COOLING EFFECT IN FISH CASES IS ACCOMPLISHED WITH A TRADITIONAL ICE BED. THE REFRIGERATION PRESERVES THE ICE AND MAINTAINS A COLD PROTECTIVE LAYER OVER THE PRODUCT.
- 6) RATING CONDITION IS NSF TYPE I, 75°F/55% RH

REFRIGERATION DATA CONTINUED:

LOCATION	ELEC. THERMOSTAT / AIR SENSOR SETTINGS		DE FROST TYPE	DE TIME (MIN)	DE FROSTS PER DAY	TERM. TEMP (°F) AIR TEMP	DRIP TIME	DEFROST WATER (LBS /DAY/FT)	FAN BLADE DIA.	FAN BLADE PITCH	
	USAGE	CUT IN (°F)									CUT OUT (°F)
TOP	MEAT / FISH	29	26	OFF TIME	40	4	NA	0.34	6.75"	N/A	
FRONT	MEAT / FISH	31	28								48
REFRIGERATED REAR STORAGE	MEAT / FISH	37	36								

END PANEL WIDTH KEY

# OF END PNLS	END PNL WIDTH (IN.)	TOTAL ADDED LENGTH (IN.)
1	1.125	1.125
2	1.125	2.25

ELECTRICAL DATA:

STANDARD FANS, HEATERS, LED LIGHTS (115 VOLT)

CASE LENGTH	TOTAL EVAPORATOR FANS			CANOPY LIGHTS LED TOP & FRONT		OPTIONAL LED SHELF LIGHTS (FRONT AND TOP)		OPTIONAL LED 2ND SHELF (TOP)		MAX. LED LOAD (W ALL OPTIONS)		ANTI-SWEAT HEATERS		REFRIGERATED REAR STORAGE (OPTIONAL) EVAP FANS			CONVENIENCE OUTLETS (OPTIONAL)		
	# OF EVAP FANS	AMPS	WATTS	AMPS	WATTS	AMPS	WATTS	AMPS	WATTS	AMPS	WATTS	AMPS	WATTS	# OF EVAP FANS	AMPS	WATTS	# OUTLETS	VOLTS	AMPS
4'	2	0.2	16	0.2	28	0.1	10	0.1	10	0.4	49	0.8	97	1	0.3	8.8	1	115	15
6'	2	0.2	16	0.4	41	0.1	15	0.1	15	0.6	72	1.3	147	1	0.3	8.8	1	115	15
8'	4	0.5	32	0.5	57	0.2	21	0.2	21	0.9	98	1.7	197	1	0.3	8.8	1	115	15
12'	6	0.7	48	0.7	85	0.3	31	0.3	31	1.3	147	2.6	297	1	0.3	8.8	2	115	30

OPTIONAL HIGH OUTPUT LED LIGHTS (115 VOLT)

CASE LENGTH	CANOPY LIGHTS H.O. LED TOP & FRONT		OPTIONAL SHELF (FRONT AND TOP)		OPTIONAL 2ND SHELF (TOP)		MAX. H.O. LED LOAD	
	AMPS	WATTS	AMPS	WATTS	AMPS	WATTS	AMPS	WATTS
4'	0.4	46	0.1	15	0.1	15	0.7	76
6'	0.7	78	0.2	26	0.2	26	1.1	130
8'	0.8	91	0.3	30	0.3	30	1.3	152
12'	1.2	137	0.4	46	0.4	46	2.0	228

Electrical

Wiring Color Code

STANDARD CASE WIRE COLOR CODE CODIGO DE COLORES DE LOS ALAMBRES PARA LAS VITRINAS ESTANDAR CODE COULER POUR FILS DE BOITIER NORMALISE		
COLOR DESCRIPTION	DESCRIPCION	DESCRIPTION
GROUND	TIERRA MASA	MASSE
ANTI-SWEAT	ANTICONDENSACION	ANTI-SUITEMENT
LIGHTS	LUCES	ECLAIRAGE
RECEPTACLES	ENCHUFES	PRISE DE COURANT
T-STAT/SOLENOID 230VAC	TERMOSTATO/SOLENOIDE (230VAC)	SOUPAPE A SOLENOID (230 VAC)
T-STAT/SOLENOID 115VAC	TERMOSTATO/SOLENOIDE (115VAC)	SOUPAPE A SOLENOID (115 VAC)
T-STAT/SOLENOID 24VAC	TERMOSTATO/SOLENOIDE (24VAC)	SOUPAPE A SOLENOID (24 VAC)
FAN MOTORS	VENTILADORES	VENTILATEUR
BLUE CONDENSING UNIT	UNIDAD DE CONDENSACION	UNITE DE CONDENSATION

USE COPPER CONDUCTORS ONLY
UTILISEZ LES CONDUCTEURS DE CUIVRE SEULEMENT
UTILICE LOS CONDUCTORES DE COBRE SOLAMENTE
 430-01-0338 R101003

CASE MUST BE GROUNDED

NOTE: Refer to label affixed to case to determine the actual configuration as checked in the "TYPE INSTALLED" boxes.

Electrical Circuit Identification

Standard lighting for all models will be full length LED lamps located within the case at the top.

The switch controlling the lights, the plug provided for digital scale, and the thermometer are located at the rear of the case mullion.

The receptacle that is provided on the exterior back of these models is intended for computerized scales with a five amp maximum load, not for large motors or other high wattage appliances. It should be wired to a dedicated circuit.

Electrical Service Receptacles (When Applicable)

The receptacles located on the exterior of the merchandiser are intended for scales and lighted displays. They are not intended nor suitable for large motors or other external appliances.



DANGER

BEFORE SERVICING
ALWAYS DISCONNECT ELECTRICAL
POWER AT THE MAIN DISCONNECT
WHEN SERVICING OR REPLACING ANY
ELECTRICAL COMPONENT.
This includes (but not limited to) Fans, Heater
Thermostats, and Lights.

Field Wiring and Serial Plate Amperage

Field Wiring must be sized for component amperes printed on the serial plate. Actual ampere draw may be less than specified. Field wiring from the refrigeration control panel to the merchandisers is required for refrigeration thermostats. Case amperes are listed on the wiring diagram, but always check the serial plate.

LED Driver Location

Drivers are located within the access panel (Electrical raceway) that runs the length of the rear of the case.

User Information

Stocking

Improper temperature and lighting will cause serious product loss. Discoloration, dehydration and spoilage can be controlled with proper use of the equipment and handling of product. Product temperature should always be maintained at a constant and proper temperature. This means that from the time the product is received, through storage, preparation and display, the temperature of the product must be controlled to maximize life of the product. Hussmann cases were not designed to “heat up” or “cool down” product - but rather to maintain an item’s proper temperature for maximum shelf life. To achieve the protection required always:

1. Minimize processing time to avoid damaging temperature rise to the product. Product should be at proper temperature.
2. Keep the air in and around the case area free of foreign gasses and fumes or food will rapidly deteriorate.
3. Maintain the display merchandisers temperature controls as outlined in the refrigerator section of this manual.
4. Do not place any product into these refrigerators until all controls have been adjusted and they are operating at the proper temperature. Allow merchandiser to operate a minimum of 6 hours before stocking with any product.
5. When stocking, never allow the product to extend beyond the recommended load limit. **Air discharge and return air flow must be unobstructed at all times to provide proper refrigeration.**
6. Keep the service doors closed (when applicable). Refrigeration performance will be seriously affected if left open for a prolonged period of time.
7. Avoid the use of supplemental flood or spot lighting. Display light intensity has been designed for maximum visibility and product life at the factory. The use of higher output LED lamps (H.O. and V.H.O.), will shorten the shelf life of the product.

Evaporator Fans

The evaporator fans are located at the center front of these merchandisers directly beneath the display pans. *Should fans or blades need servicing, always replace fan blades with the raised embossed side of the blade TOWARD THE MOTOR.*

Copper Coils

The copper coils used in Hussmann merchandisers may be repaired in the field. Materials are available from local refrigeration wholesalers.

Hussmann recommends using #15 Sil-Fos for repairs.

Aluminum Coils

The aluminum coils should be replaced if damaged.

Non-Glare Glass (Optional)

The high optical clarity of this glass is possible due to special coatings on the glass surface itself. To preserve this coating and the optical clarity, keep the glass clean.

Water is the only solution recommended to be used to clean the non-glare glass. The damage to the glass from improper, caustic solutions is irreparable.

In addition to cleaning the glass with the recommended product, there are precautions that should be taken when working and cleaning the inside of the case.

- When cleaning the inside of the cases, we recommend that the glass be fully opened and covered to prevent solutions from splashing onto the glass and ruining the coating on the inside.
- Only use a soft cloth and water (in a spray bottle) for cleaning any glass or mirrored components. Be sure to rinse and/or dry completely.
- **Never use hot water on cold glass surfaces! It may shatter and cause serious injury!** Allow glass surfaces to warm to room temperature.

Plexiglass and Acrylic Care

Improper cleaning not only accelerates the cleaning cycle but also degrades the quality of this surface. Normal daily buffing motions can generate static cling attracting dust to the surface. Incorrect cleaning agents or cleaning cloths can cause micro scratching of the surface, causing the plastic to haze over time.

Cleaning

Hussmann recommends using a clean damp chamois, or a paper towel marketed as dust and abrasive free with **210® Plastic Cleaner and Polish** available by calling Sumner Labs at **1-800-542-8656**. Hard, rough cloths or paper towels will scratch the acrylic and should not be used.

Antistatic Coatings

The product **210®** has proven to be very effective in not only cleaning and polishing the Plexiglass surface, but also providing anti-static and anti-fog capabilities. This product also seals pores and provides a protective coating.

Tips and Troubleshooting

Before calling for service, check the following:

1. Check electrical power supply to the equipment for connection.
2. Check fixture loading. Overstocking case will affect its proper operation.
3. If frost is collecting on fixture and/or product, check that no outside doors or windows are open allowing moisture to enter store. These merchandisers were designed for use in stores where temperature & humidity does not exceed 75° F and 55% H.
4. If front self-service case is not performing check proper installation of lower deck pan refer to case cleaning section.

User Information (Cont'd)

Case Cleaning

Long life and satisfactory performance of any equipment are dependent upon the care given to it. To insure long life, proper sanitation and minimum maintenance costs, the refrigerator should be thoroughly cleaned frequently.

SHUT OFF FAN DURING CLEANING PROCESS. It can be unplugged within the case, or shut off case at the source. The interior bottom may be cleaned with any domestic soap or detergent based cleaners. Sanitizing solutions will not harm the interior bottom, however, these solutions should always be used according to the manufacturer's directions.

It is essential to establish and regulate cleaning procedures. This will minimize bacteria causing discoloration which leads to degraded product appearance and significantly shortening product shelf life.

Soap and hot water are NOT enough to kill this bacteria. A sanitizing solution MUST be included with each cleaning process to eliminate this bacteria.

Remove all food stuffs, ice, debris, etc., and either access the case from the rear or the front of the case. Allow the case to come to room temperature.

the front glass is "lift up glass" and is NOT sealed. IT WILL LEAK.) Keep all water within the base of the case.

3. Apply the sanitizing solution according to the manufacturer's directions.
4. Rinse thoroughly.
5. Dry completely before resuming operation.

CAUTION

CLEANING PRECAUTIONS

- When cleaning:
- Do not use high pressure water hoses
 - Do not introduce water faster than waste outlet can drain
 - NEVER INTRODUCE WATER ON SELF CONTAINED UNIT WITH AN EVAPORATOR PAN
 - NEVER USE A CLEANING OR SANITIZING SOLUTION THAT HAS AN OIL BASE (these will dissolve the butyl sealants) or an AMMONIA BASE (this will corrode the copper components of the case)
 - TO PRESERVE THE ATTRACTIVE FINISH:
 - DO USE WATER AND A MILD DETERGENT FOR THE EXTERIOR ONLY
 - DO NOT USE A CHLORANITED CLEANER ON ANY SURFACE
 - DO NOT USE ABRASIVES OR STEEL WOOL SCOURING PADS (these will mar the finish)



CAUTION
 WHEN CLEANING, DO NOT SPRAY GLASS!
 FRONT AND BACK GLASS IS NOT SEALED AND WILL LEAK!!!
 Front glass is "Lift Up Glass" that is NOT SEALED and back access doors ARE NOT SEALED and WILL LEAK if sprayed with any liquid!



CAUTION
 If you access the case from the front, be certain the glass is FULLY upright before beginning the cleaning process.

1. Scrub thoroughly, cleaning all surfaces, with soap and hot water.
2. Rinse with hot water, but DO NOT flood or spray glass. (If you are working from the rear of the case,

User Information (Cont'd)

Front Deck Pan Placement

ATTENTION!

When reassembling the front self-service portion of the case, assure proper installation of bottom deck pan. If the deck pan is NOT installed properly, the front self service section will NOT maintain safe product temperature.



Stainless Steel Cleaning and Care

There are three basic things, which can break down your stainless steel's passivity layer and allow corrosion.

1. Mechanical Abrasion

Mechanical Abrasion means those things that will scratch the steel's surface. Steel Pads, wire Brushes, and Scrapers are prime examples.

2. Water

Water comes out of our tap in varying degrees of hardness. Depending on what part of the country you live in, you may have hard or soft water. Hard water may leave spots. Also, when heated, hard water leaves deposits behind that if left to sit, will break down the passive layer and rust your stainless steel. Other deposits from food preparation and service must be properly removed.

3. Chlorides

Chlorides are found nearly everywhere. They are in water, food and table salt. One of the worst perpetrators of chlorides can come from household and industrial cleaners.

Don't Despair! Here are a few steps that can help prevent stainless steel rust.

1. Use the Proper Tools

When cleaning your stainless steel products, take care to use non-abrasive tools. Soft Clothes and plastic scouring pads will NOT harm the steel's passive layer. Stainless steel pads can also be used but the scrubbing motion must be in the same direction of the manufacturer's polishing marks.

2. Clean With the Polish Lines

Some stainless steels come with visible polishing lines or "grain". When visible lines are present, you should ALWAYS scrub in a motion that is parallel to them. When the grain cannot be seen, play it safe and use a soft cloth or plastic scouring pad.

3. Use Alkaline, Alkaline Chlorinated or Non-chloride Containing Cleaners

While many traditional cleaners are loaded with chlorides, the industry is providing an ever increasing choice of non-chloride cleaners. If you are not sure of your cleaner's chloride content contact your cleaner supplier. If they tell you that your present cleaner contains chlorides, ask for an alternative. Also, avoid cleaners containing quaternary salts as they also can attack stainless steel & cause pitting and rusting.

4. Treat your Water

Though this is not always practical, softening hard water can do much to reduce deposits. There are certain filters that can be installed to remove distasteful and corrosive elements. Salts in a properly maintained water softener are your friends. If you are not sure of the proper water treatment, call a treatment specialist.

5. Keep your Food Equipment Clean

Use alkaline, alkaline chlorinated or non-chlorinated cleaners at recommended strength. Clean frequently to avoid build-up of hard, stubborn stains. If you boil water in your stainless steel equipment, remember the single most likely cause of damage is chlorides in the water. Heating cleaners that contain chlorides has a similar effect.

6. RINSE, RINSE, RINSE

If chlorinated cleaners are used you must rinse, rinse, rinse and wipe dry immediately. The sooner you wipe off standing water, especially when sit contains cleaning agents, the better. After wiping the equipment down, allow it to air dry for the oxygen helps maintain the stainless steel's passivity film.

7. Never Use Hydrochloric Acid (Muriatic Acid) on Stainless Steel

8. Regularly Restore/Passivate Stainless Steel

Electrical Wiring Diagrams

R3M/F - HV HIGH VOLUME	4'	1H23786
	6'	1H23787
	8'	1H23788
	12'	1H23789

CIRCUIT #1

LOADING	
120V	
L1	1.5

NOTE: CASE MUST BE GROUNDED

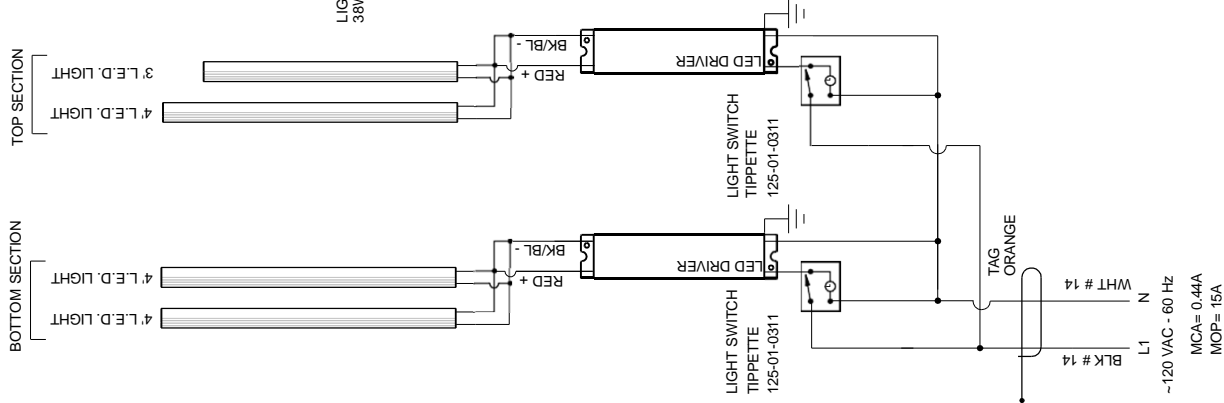

EV/APFANS
(2) 3174935
0.07A 12W @ 120V

RL-45 NETWORK JACK
125-01-0200
125-01-0203
125-01-0204
COMMUNICATION
CONNECTION TO BE
DONE IN FIELD



CIRCUIT #2 (optional)

LOADING	
120V	
L1	15.0

BUNDLE YELLOW

ALL SINGLE RECEPTACLES TO BE TIED TO DUPLEX GFCI RECEPTACLE

NOTE FOR GFCI PROTECTION: IF MORE THAN ONE SINGLE RECEPTACLE IS USED IN CONJUNCTION WITH A GFCI DUPLEX RECEPTACLE "DOWNSTREAM" ON THE LOAD SIDE, THE SUM OF ALL RECEPTACLES SHOULD NOT BE MORE THAN 15A

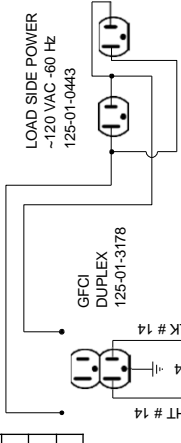

LIGHT CIRCUIT (INPUT)
38W 0.35A @ 120VAC

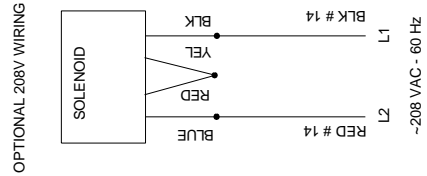

OPTIONAL

SUCTION SOLENOID
.14A @ 120VAC

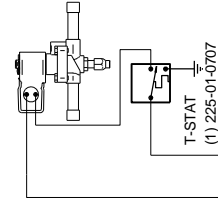

OPTIONAL

SUCTION SOLENOID
.14A @ 120VAC

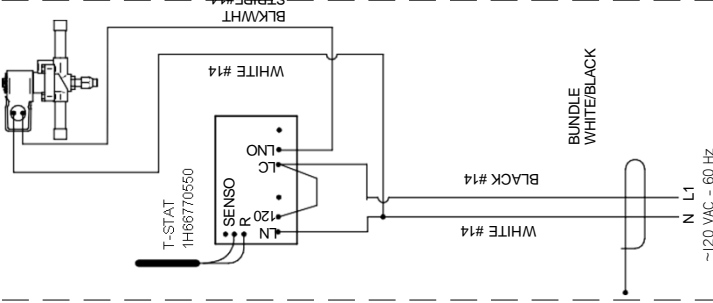

HTR ELMT
97W 0.84A @ 120V
1H96920550

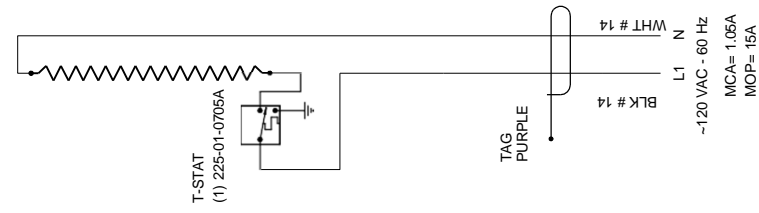

REVISIONS:

#:	DESCRIPTION:	DATE:	BY:	CHECKED BY:	DATE:
C	ECN-CAP-0000255 REMOVED ARM HEATERS	6/7/16	CB	JESSE RIOS	6/5/09
D	ECN-CAP-0012690 ADDED FAN, DIGITAL T-STAT	5/4/18	CB		
E	ECN-COD-0018141 CHANGED FAN MOTOR	7/5/23	CB		

PROJECT TITLE: **R3-HV-M/F- 4FT**
DRAWING TITLE: **DIAGRAM-R3-HV-MEAT/FISH 4FT**

DRAWING #: **1H23786**
PAGE 1 OF 1

CIRCUIT #1

LOADING	
120V	
L1	2.3

NOTE: CASE MUST BE GROUNDED

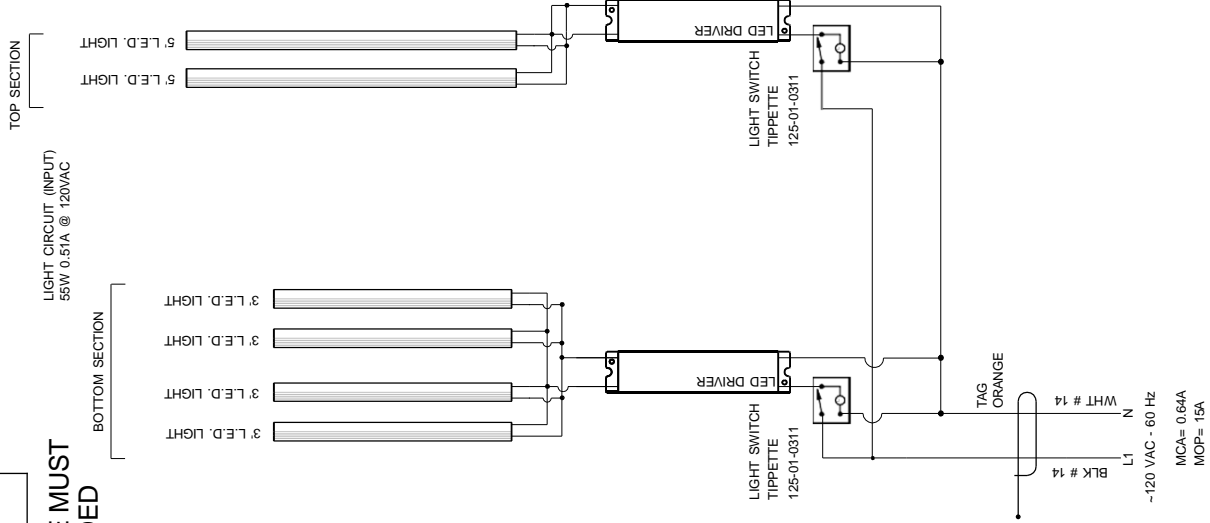

RJ-45 NETWORK JACK
125-01-0200
125-01-0203
125-01-0204
COMMUNICATION
CONNECTION TO BE
DONE IN FIELD



CIRCUIT # 2 (optional)

LOADING	
120V	
L1	15.0

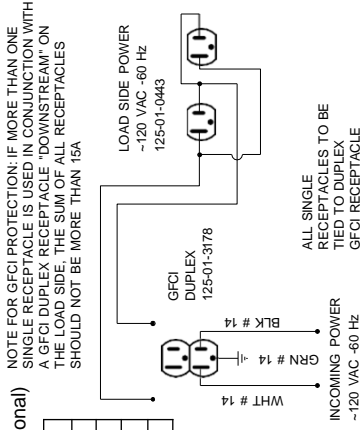

ALL SINGLE RECEPTACLES TO BE TIED TO DUPLEX GFCI RECEPTACLE

OPTIONAL 208V WIRING

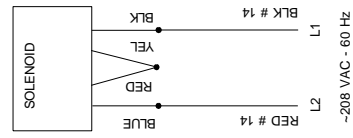

SUCTION SOLENOID
(1) 225-01-3202
.16A @ 120VAC

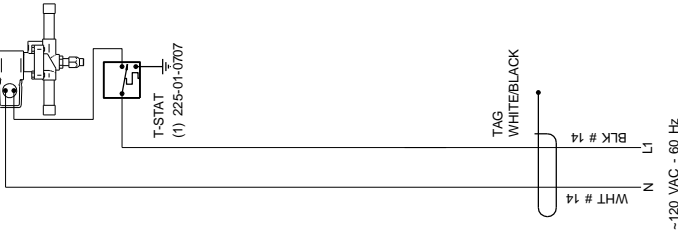

EVAP FANS
(3) 3174935
12W 0.07A @ 120V

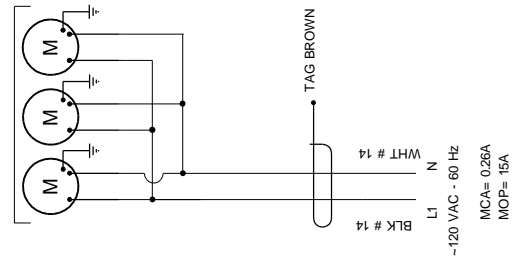

HTR ELMT
147W 1.28A @ 120V
1H86821550

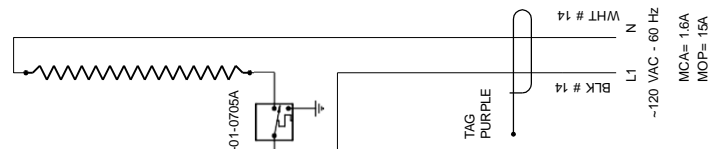

DRAWN BY: JESSE RIOS

CHECKED BY:

DATE: 6/5/09

PRODUCTION ORDER #:

FILE LOCATION:

REVISIONS:

#	DESCRIPTION:	DATE:	BY:
C	ECN-CAP-0000255, ADDED DUAL VOLTAGE WIRING	6/2/16	CB
D	ECN-CAP-0012698, ADDED REAR STORAGE OPTION	5/31/18	CB
E	ECN-COD-0018141, CHANGED FAN MOTOR	7/5/23	CB

HUSSMANN
Hussmann Corporation, Intl.
13770 Ramona Avenue
Chino, CA, 91710
(909)-590-4910 Lic.#: 644406

PROJECT TITLE: R3-HV-F/M-6

DRAWING TITLE:

DIAGRAM-R3-HV-MEAT/FISH 6FT

DRAWING #: 1H23787

OPTIONAL REAR STORAGE

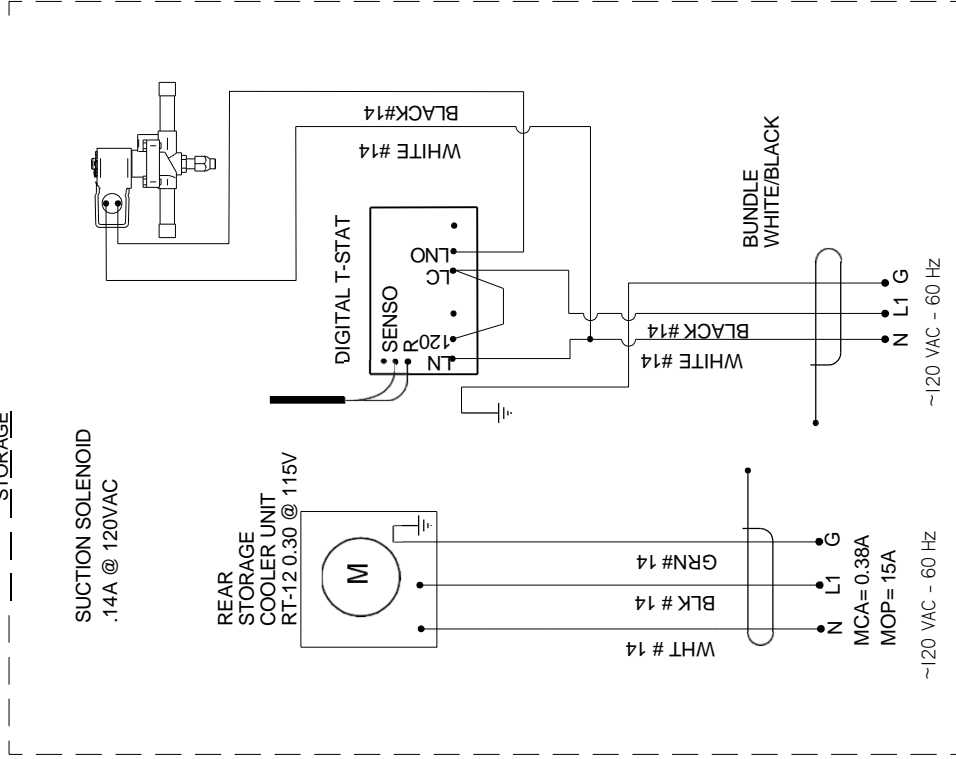

SUCTION SOLENOID
.14A @ 120VAC

REAR STORAGE COOLER UNIT
RT-12 0.30 @ 115V

DIGITAL T-STAT

SENSE
R
L
N
L1
L2
L3
G

WHT # 14
BLK # 14
GRN # 14

N
L1
G

MCA= 0.38A
MOP= 15A

~120 VAC - 60 HZ

BUNDLE
WHITE/BLACK

WHT # 14
BLK # 14

N
L1
G

~120 VAC - 60 HZ

REVISIONS:

#	DESCRIPTION:	DATE:	BY:
C	ECN-CAP-0000255, ADDED DUAL VOLTAGE WIRING	6/2/16	CB
D	ECN-CAP-0012698, ADDED REAR STORAGE OPTION	5/31/18	CB
E	ECN-COD-0018141, CHANGED FAN MOTOR	7/5/23	CB

DRAWN BY: JESSE RIOS	DATE: 6/5/09
CHECKED BY:	PRODUCTION ORDER #:
FILE LOCATION:	

CIRCUIT #1

LOADING	
120V	
L1	3.0

NOTE: CASE MUST BE GROUNDED

LIGHT CIRCUIT (INPUT)
75W 0.68A @ 120VAC

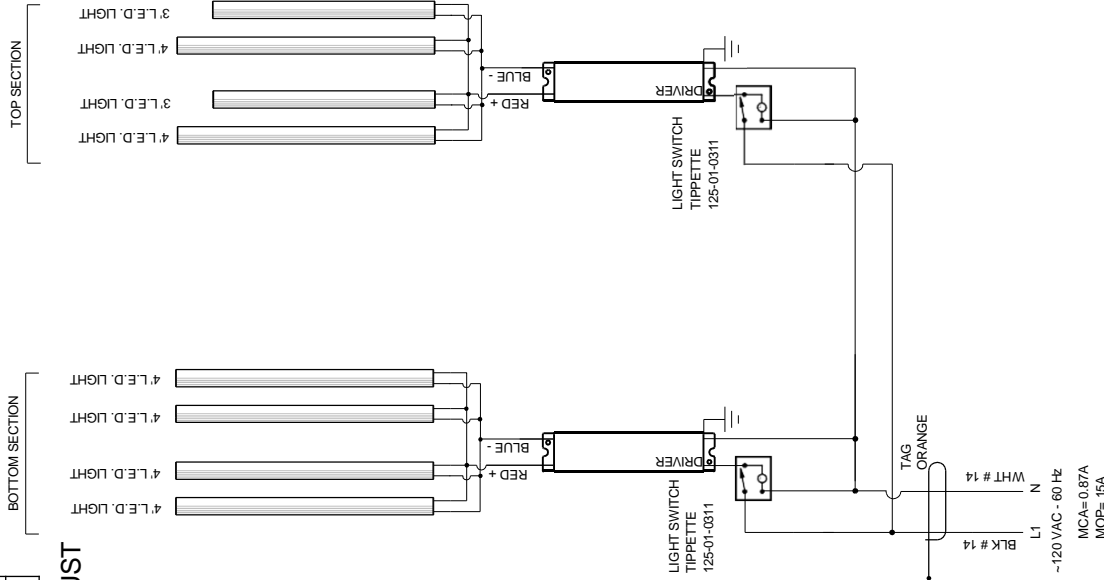

RA45 NETWORK JACK
125-01-0203
125-01-0203
125-01-0204
COMMUNICATION
CONNECTION TO BE
DONE IN FIELD

CIRCUIT # 2 (optional)

LOADING	
120V	
L1	15.0

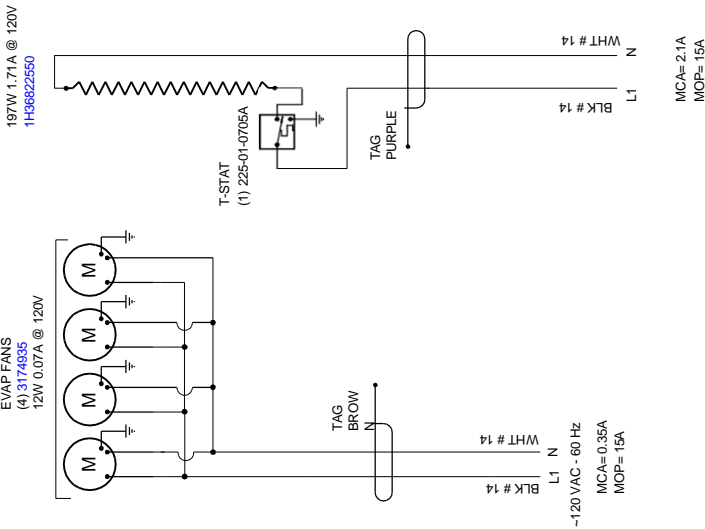
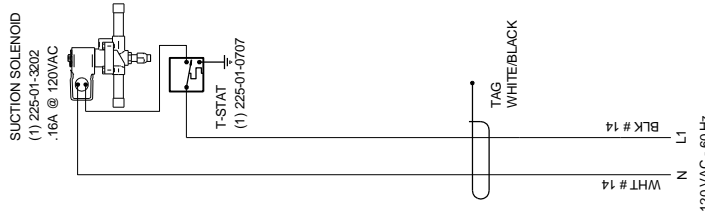
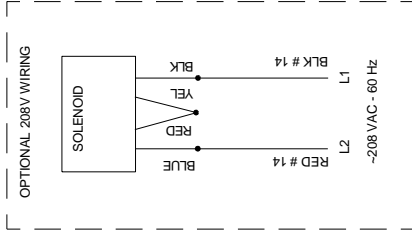
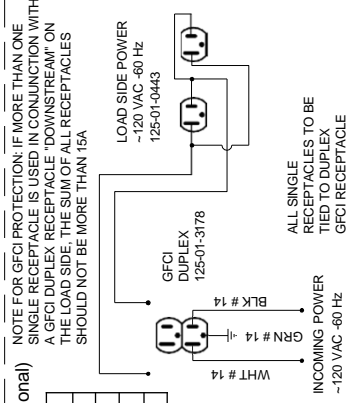

REVISIONS:

#	DESCRIPTION:	DATE:	BY:	CHECKED BY:	DATE:
C	ECN-CAP-0000255 REMOVED ARM HEATERS	6/7/16	CB		6/5/09
D	ECN-CAP-0012698 ADDED REAR STORAGE OPTION	5/31/18	CB		
E	ECN-COD-0018141 CHANGED FAN MOTOR	7/5/23	CB		

DRAWN BY: JESSE RIOS
PROJECT TITLE: R3-HV-M/F
DRAWING TITLE: DIAGRAM-R3-HV-MEAT/FISH 8FT

OPTIONAL REAR
STORAGE

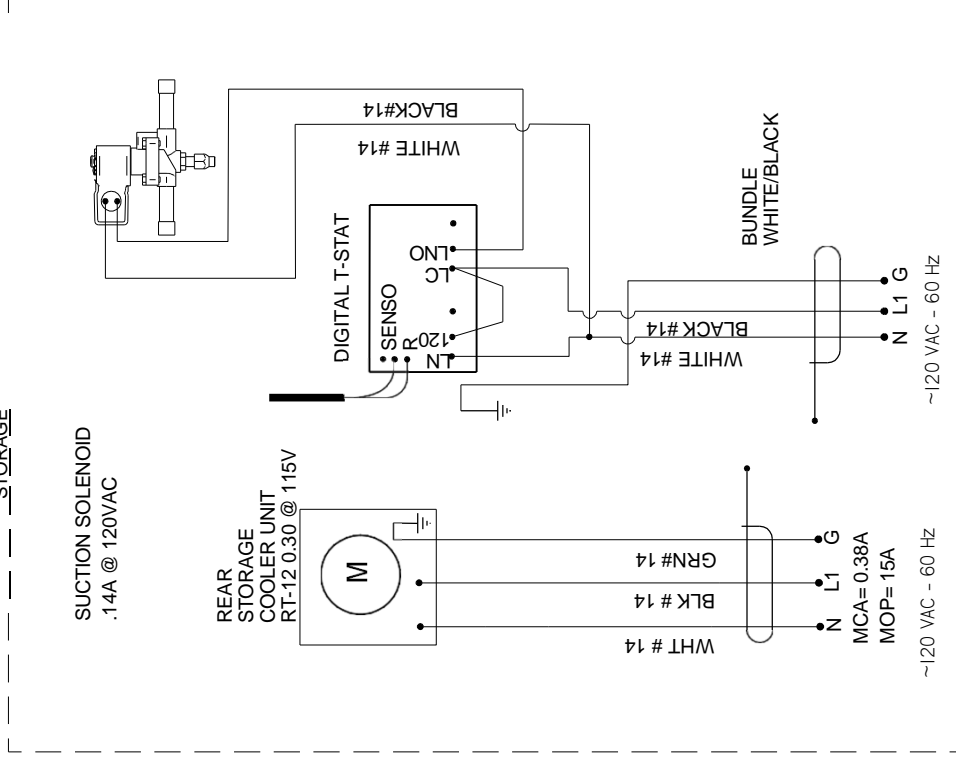

REVISIONS:

#	DESCRIPTION:	DATE:	BY:	CHECKED BY:	DATE:
C	ECN-CAP-0000255 REMOVED ARM HEATERS	6/7/16	CB		6/5/09
D	ECN-CAP-0012698 ADDED REAR STORAGE OPTION	5/31/18	CB		
E	ECN-COD-0018141 CHANGED FAN MOTOR	7/5/23	CB		

DRAWN BY: JESSE RIOS	PROJECT TITLE: R3-HV-M/F	DRAWING #: 1H23788
FILE LOCATION:	DIAGRAM-R3-HV-MEAT/FISH 8FT	
PRODUCTION ORDER #:		

CIRCUIT #1

LOADING	
120V	
L1	4.4

NOTE: CASE MUST BE GROUNDED

LIGHT CIRCUIT (INPUT)
113W 1.04A @ 120VAC

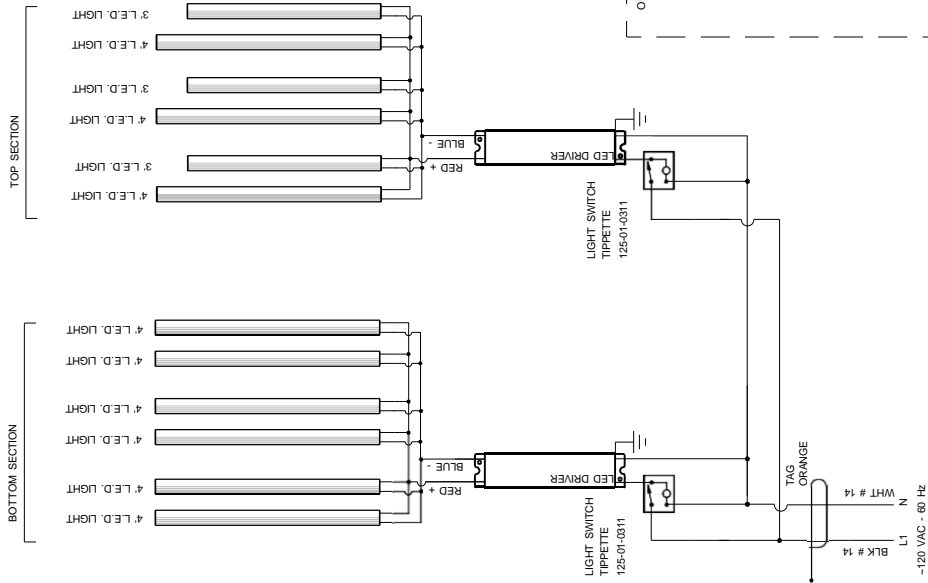

RL45 NETWORK JACK
125-01-0200
125-01-0203
125-01-0204
CONNECTION
COMPLETION TO BE
DONE IN FIELD

LOADING	
120V	
L1	15.0

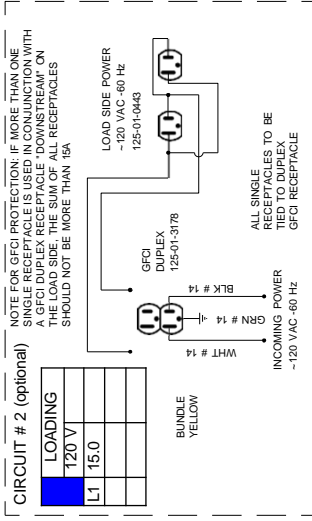

SUCTION SOLENOID
(1) 225-01-1302
.16A @ 120VAC

HTR ELMT 138"
287W 2.5A @ 120V
1H08823550

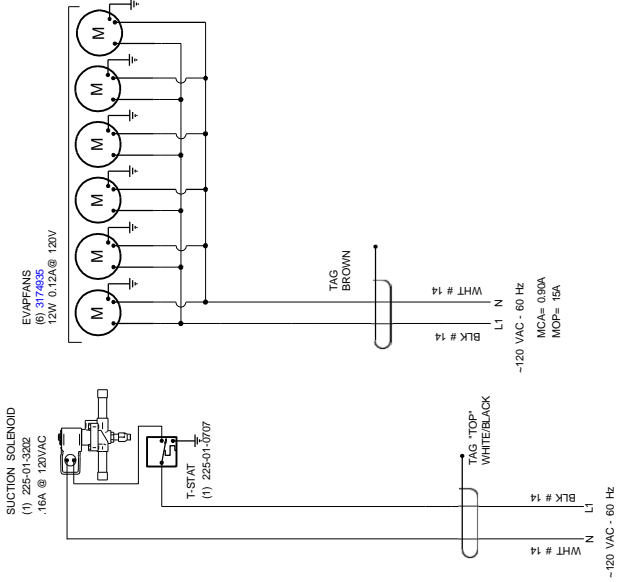

EVAPFANS
(6) 3174935
12W 0.12A @ 120V

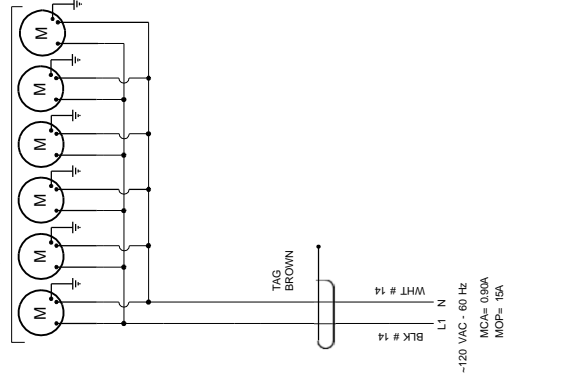

REVISIONS:

#	DESCRIPTION:	DATE:	BY:
B	CHGD TO L.E.D.	10/28/11	CB
C	ECN-CAP-0000255 REMOVED ARM HEATERS	6/7/16	CB
D	ECN-COD-0018141 CHANGED FAN MOTORS	7/5/23	CB

DRAWN BY: JESSE RIOS

CHECKED BY: DATE: 6/5/09

PROJECT TITLE: R3-HV-M/F

DRAWING TITLE:

DRAWING #: 1H23789

DIAGRAM-R3-HV-MEAT/FISH 12FT

PAGE 1 OF 1

Appendices

Appendix A. - Temperature Guidelines

The refrigerators should be operated according to the manufacturer's published engineering specifications for entering air temperatures for specific equipment applications. Table 1 shows the typical temperature of the air entering the food zone one hour before the start of defrost and one hour after defrost for various categories of refrigerators. Refer to Appendix C for Field Evaluation Guidelines.

Type of Refrigerator	Typical Entering Air Temperature
I. OPEN DISPLAY	
A. Non frozen:	
1) Meat	28°F
2) Dairy/Deli	32°F
3) Produce	
a. Processed	36°F
b. Unprocessed	45°F
B. Frozen	0°F
C. Ice Cream	-5°F
II. CLOSED DISPLAY	
A. Non frozen:	
1) Meat	34°F
2) Dairy/Deli	34°F
3) Produce	
a. Processed	36°F
b. Unprocessed	45°F
B. Frozen	0°F
C. Ice Cream	-5°F

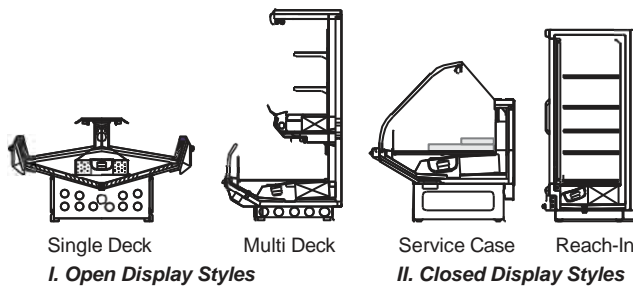

Appendix B. - Application Recommendations

1. Temperature performance is critical for controlling bacteria growth. Therefore, the following recommendations are included in the standard. They are based on confirmed field experience over many years.
2. The installer is responsible for following the installation instructions and recommendations provided by Hussmann for the installation of each individual type refrigerator.
2. Refrigeration piping should be sized according to the equipment manufacturer's recommendations and installed in accordance with normal refrigeration practices. Refrigeration piping should be insulated according to Hussmann's recommendations.

- 1.3 A clogged waste outlet blocks refrigeration. The installer is responsible for the proper installation of the system which dispenses condensate waste through an air gap into the building indirect waste system.
4. The installer should perform a complete start-up evaluation prior to the loading of food into the refrigerator, which includes such items as:
 - a) Initial temperature performance, Coils should be properly fed with a refrigerant according to manufacturer's recommendations.
 - b) Observation of outside influences such as drafts, radiant heating from the ceiling and from lamps. Such influence should be properly corrected or compensated for.
 - c) At the same time, checks should be made of the store dry-bulb and wet-bulb temperatures to ascertain that they are within the limits prescribed by Hussmann.
 - d) Complete start-up procedures should include checking through a defrost to make certain of its adequate frequency and length without substantially exceeding the actual needs. This should include checking the electrical or refrigerant circuits to make sure that defrosts are correctly programmed for all the refrigerators connected to each refrigeration system.
 - e) Recording instruments should be used to check performance.

Appendix C. - Field Recommendations
Recommendations for field evaluating the performance of retail food refrigerators and hot cases

- 1.0 The most consistent indicator of display refrigerator performance is temperature of the air entering the product zone (see Appendix A). In practical use, the precise determination of return air temperature is extremely difficult. Readings of return air temperatures will be variable and results will be inconsistent. The product temperature alone is not an indicator of refrigerator performance.

NOTE: Public Health will use the temperature of the product in determining if the refrigerator will be allowed to display potentially hazardous food. For the purpose of this evaluation, product temperature above the FDA Food Code 1993 temperature for potentially hazardous food will be the first indication that an evaluation should be performed. It is expected that all refrigerators will keep food at the FDA Food Code 1993 temperature for potentially hazardous food.

Appendices (Cont'd)

1. The following recommendations are made for the purpose of arriving at easily taken and understood data which, coupled with other observations, may be used to determine whether a display refrigerator is working as intended:
 - a) INSTRUMENT - A stainless steel stem-type thermometer is recommended and it should have a dial a minimum of 1 inch internal diameter. A test thermometer scaled only in Celsius or dually scaled in Celsius and Fahrenheit shall be accurate to 1°C (1.8°F). Temperature measuring devices that are scaled only in Fahrenheit shall be accurate to 2°F. The thermometer should be checked for proper calibration. (It should read 32°F when the stem is immersed in an ice water bath).
 - b) LOCATION - The probe or sensing element of the thermometer should be located in the airstream where the air first enters the display or storage area, and not more than 1 inch away from the surface and in the center of the discharge opening.
 - c) READING - It should first be determined that the refrigerator is refrigerating and has operated at least one hour since the end of the last defrost period. The thermometer reading should be made only after it has been allowed to stabilize, i.e., maintain a constant reading.
 - d) OTHER OBSERVATIONS - Other observations should be made which may indicate operating problems, such as unsatisfactory product, feel/appearance.
 - e) CONCLUSIONS - In the absence of any apparent undesirable conditions, the refrigerator should be judged to be operating properly. If it is determined that such condition is undesirable, i.e., the product is above proper temperature, checks should be made for the following:
 1. Has the refrigerator been loaded with warm product?
 2. Is the product loaded beyond the "Safe Load Line" markers?
 3. Are the return air ducts blocked?
 4. Are the entering air ducts blocked?
 5. Is a dumped display causing turbulent air flow and mixing with room air?
 6. Are spotlights or other high intensity lighting directed onto the product?
7. Are there unusual draft conditions (from heating/air-conditioning ducts, open doors, etc.)?
8. Is there exposure to direct sunlight?
9. Are display signs blocking or diverting airflow?
10. Are the coils of the refrigerator iced up?
11. Is the store ambient over 75°F, 55% RH as set forth in ASHRAE Standard 72 and ASHRAE Standard 117?
12. Are the shelf positions, number, and size other than recommended by Hussmann?
13. Is there an improper application or control system?
14. Is the evaporator fan motor/blade inoperative?
15. Is the defrost time excessive?
16. Is the defrost termination, thermostat (if used) set too high?
17. Are the refrigerant controls incorrectly adjusted?
18. Is the air entering the condenser above design conditions? Are the condenser fins clear of dirt, dust, etc.?
19. Is there a shortage of refrigerant?
20. Has the equipment been modified to use replacements for CFC-12, CFC-502 or other refrigerant? If so, have the modifications been made in accordance with the recommendations of the equipment manufacturer? Is the refrigerator charged with the proper refrigerant and lubricant? Does the system use the recommended compressor?

Appendix D. - Recommendations to User

- 1.0 Hussmann Corporation provides instructions and recommendations for proper periodic cleaning. The user will be responsible for such cleaning, including the cleaning of low temperature equipment within the compartment and the cooling coil area(s). Cleaning practices, particularly with respect to proper refrigerator unloading and warm-up, must be in accordance with applicable recommendations.

Appendices (Cont'd)

- 1.1 Cleaning of non frozen food equipment should include a weekly cleaning of the food compartment as a minimum to prevent bacteria growth from accumulating. Actual use and products may dictate more frequent cleaning. Circumstances of use and equipment design must also dictate the frequency of cleaning the display areas. Weekly washing down of the storage compartment is also recommended, especially for equipment subject to drippage of milk or other liquids, or the collection of vegetable, meat, crumbs, etc. or other debris or litter. Daily cleaning of the external areas surrounding the storage or display compartments with detergent and water will keep the equipment presentable and prevent grime buildup.
2. Load levels as defined by the manufacturer must be observed.
3. The best preservation is achieved by following these rules:
 - a) Buy quality products.
 - b) Receive perishables from transit equipment at the ideal temperature for the particular product.
 - c) Expedite perishables to the store's storage equipment to avoid unnecessary warm-up and prolonged temperature recovery. Food store refrigerators are not food chillers nor can they reclaim quality lost through previous mishandling.
 - d) Care must be taken when cross merchandising products to ensure that potentially hazardous vegetable products are not placed in non refrigerated areas.
 - e) Display and storage equipment doors should be kept closed during periods of inactivity.
 - f) Minimize the transfer time of perishables from storage to display.
 - g) Keep meat under refrigeration in meat cutting and processing area except for the few moments it is being handled in processing. When a cut or tray of meat is not to be worked on immediately, the procedure should call for returning it to refrigeration.
 - h) Keep tools clean and sanitized. Since mechanical equipment is used for fresh meat processing, all such equipment should be cleaned at least daily and each time a different kind of meat product comes in contact with the tool or equipment.
 - i) Make sure that all refrigeration equipment is installed and adjusted in strict accordance with the manufacturer's recommendations.
 - j) See that all storage and refrigeration equipment is kept in proper working order by routine maintenance.



This warning does not mean that Hussmann products will cause cancer or reproductive harm, or is in violation of any product-safety standards or requirements. As clarified by the California State government, Proposition 65 can be considered more of a ‘right to know’ law than a pure product safety law. When used as designed, Hussmann believes that our products are not harmful. We provide the Proposition 65 warning to stay in compliance with California State law. It is your responsibility to provide accurate Proposition 65 warning labels to your customers when necessary. For more information on Proposition 65, please visit the California State government website.

Service Record

Last service date: By:

_____	_____
_____	_____
_____	_____
_____	_____
_____	_____
_____	_____
_____	_____
_____	_____

HUSSMANN®/Chino

Additional copies of this publication may be obtained by contacting:
 Hussmann® Chino
 13770 Ramona Avenue • Chino, California 91710
 (909) 628-8942 FAX
 (909) 590-4910
 (800) 395-9229

<p>The <i>MODEL NAME</i> and <i>SERIAL NUMBER</i> is required in order to provide you with the correct parts and information for your particular unit. They can be found on a small metal plate on the unit. Please note them below for future reference.</p> <p>MODEL:</p> <p>SERIAL NUMBER:</p>
