

R3B, R3D, R3P, R3TO

REFRIGERATED BAKERY, SERVICE-
SELF-SERVICE MERCHANDISER,
REFRIGERATED DELI SERVICE
TOP/SELF SERVICE FRONT, PREP
WITH REFRIGERATED SELF SERVICE
FRONT, R3TO SERVICE TOP ONLY FOR
IN-COUNTER INSTALLATION

REV. 1123



HUSSMANN®

R3B, R3D, R3P, R3TO
REFRIGERATED BAKERY, SERVICE- SELF-SERVICE
MERCHANDISER, REFRIGERATED DELI SERVICE
TOP/SELF SERVICE FRONT, PREP WITH
REFRIGERATED SELF SERVICE FRONT, R3TO
SERVICE TOP ONLY FOR IN-COUNTER INSTALLATION

1. General Instructions

HUSSMANN®/CHINO

A publication of HUSSMANN® Chino
13770 Ramona Avenue • Chino, California 91710
(909) 628-8942 FAX
(909) 590-4910
(800) 395-9229

www.hussmann.com

This Booklet Contains Information on:

R3B: Refrigerated Straight or Curved Glass, Service-Self-Service Bakery Merchandiser with Rear Storage

R3D: Refrigerated Service Deli Top/Self Service Front Merchandiser

R3P: Service Prep Top/Refrigerated Self-Service Front Case

R3TO: Service Top only for in-counter installation

Shipping Damage

All equipment should be thoroughly examined for shipping damage before and during unloading.

This equipment has been carefully inspected at our factory and the carrier has assumed responsibility for safe arrival. If damaged, either apparent or concealed, claim must be made to the carrier.

Apparent Loss or Damage

If there is an obvious loss or damage, it must be noted on the freight bill or express receipt and signed by the carrier's agent; otherwise, carrier may refuse claim. The carrier will supply necessary claim forms.

Concealed Loss or Damage

When loss or damage is not apparent until after equipment is uncrated, a claim for concealed damage is made. Make request in writing to carrier for inspection within 15 days, and retain all packaging. The carrier will supply inspection report and required claim forms.

Shortages

Check your shipment for any possible shortages of material. If a shortage should exist and is found to be the responsibility of Hussmann Chino, notify Hussmann Chino. If such a shortage involves the carrier, *notify the carrier immediately*, and request an inspection. Hussmann Chino will acknowledge shortages within ten days from receipt of equipment.

Hussmann Chino Product Control

The serial number and shipping date of all equipment has been recorded in Hussmann's files for warranty and replacement part purposes. All correspondence pertaining to warranty or parts ordering must include the serial number of each piece of equipment involved, in order to provide the customer with the correct parts.

Keep this booklet with the case at all times for future reference.

2. Table of Contents

1. General Instructions.....	2
2. Table of Contents	3
3. Cut and Plan Views	4
4. Installation.....	5
5. Plumbing	10
6. Refrigeration	10
7. Electrical.....	15
8. User Information.....	16
9. Shelf Weight Limits	18
10. Electrical Wiring Diagrams.....	19
11. Wiring Diagrams	20
12. Troubleshooting Guide	50

3. Cut and Plan Views

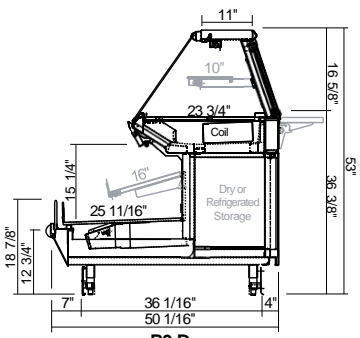

R3-D
Deli with Straight Glass,
Optional Shelves and Wrapping Board
Scale = 1/2"

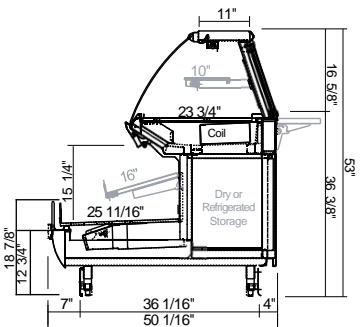

CR3-D
Deli with Curved Glass,
Optional Shelves and Wrapping Board
Scale = 1/2"

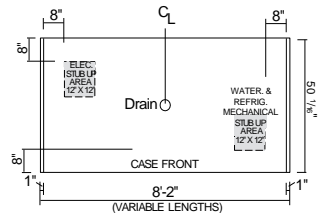

R3 / CR3
Plan View

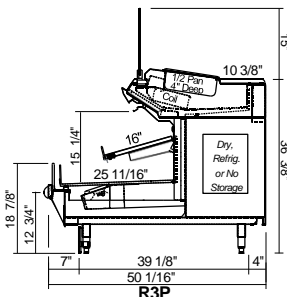

R3P
Straight Glass - Prep Top with
Refrigerated Self Service Front
Scale = 1/2"

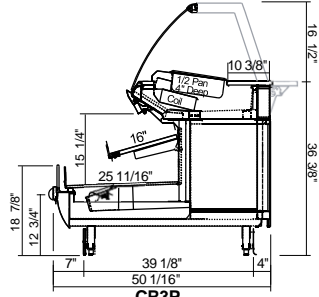

CR3P
Curved Glass - Prep Top with
Refrigerated Self Service Front
Scale = 1/2"

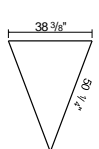

R3P 45°
INSIDE WEDGE

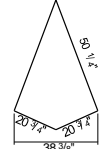

R3P 45°
OUTSIDE WEDGE

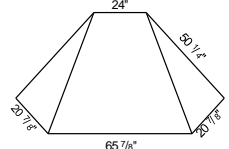

R3P 90°
OUTSIDE WEDGE

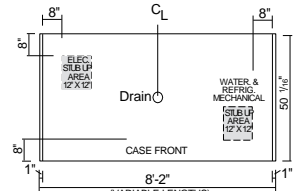

R3 / CR3
Plan View
Scale = 1/4"

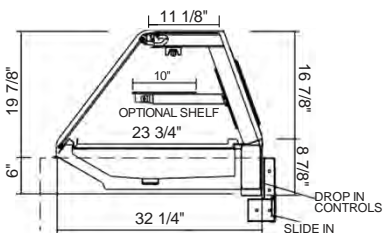

R3TO
Standard "Drop-In" with
Controls Mounted on Rear Counter Face
Scale = 1/2"

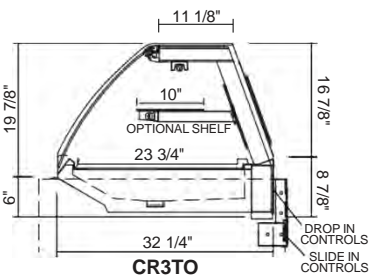

CR3TO
Refrigerated
Service / Self Service / Prep Case
Scale = 1/2"

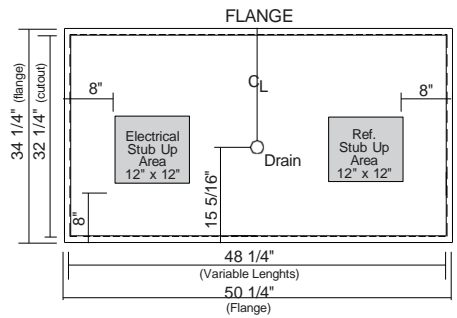

R3TO / CR3TO
Plan View

4. Installation

Location

The refrigerated merchandisers have been designed for use only in air conditioned stores where temperature and humidity are maintained at or below 75°F and 55% relative humidity. DO NOT allow air conditioning, electric fans, ovens, open doors or windows (etc.) to create air currents around the merchandiser, as this will impair its correct operation.

Product temperature should always be maintained at a constant and proper temperature. This means that from the time the product is received, through storage, preparation and display, the temperature of the product must be controlled to maximize life of the product.

Uncrating the Stand

Place the fixture as close to its permanent position as possible. Remove the top of the crate. Detach the walls from each other and remove from the skid. Unbolt the case from the skid. The fixture can now be lifted off the crate skid. **Lift only at base of stand!**

Exterior Loading

These models have not been structurally designed to support excessive external loading. **Do not walk on their tops;** This could cause serious personal injury and damage to the fixture.



Glass Adjustment

During shipment, the lubricant inside the cylinders may have settled. This settling may cause excessive or uneven tension on the glass - to the point of breakage. To avoid any damage, please follow these three easy steps:

1. Slowly raise and lower each glass section 6 times to a height of 6 inches.
2. Increase the height to 12 inches, and raise and lower the glass 6 more times.
3. Finally raise the glass to its full extension, and lower.

These steps should release any settled lubricant within the cylinders and prevent any stress on the front glass.

Setting and Joining

The sectional construction of these models enable them to be joined in line to give the effect of one continuous display. A joint trim kit is supplied with each joint.

Leveling

IMPORTANT! IT IS IMPERATIVE THAT CASES BE LEVELED FROM FRONT TO BACK AND SIDE TO SIDE PRIOR TO JOINING. A LEVEL CASE IS NECESSARY TO INSURE PROPER OPERATION, WATER DRAINAGE, PLEXIGLASS ALIGNMENT.

NOTE: A. To avoid removing concrete flooring, begin lineup leveling from the highest point of the store floor.

B. When wedges are involved in a lineup, set them first.

All cases were leveled and joined prior to shipment to insure the closest possible fit when cases are joined in the field. When joining, use a carpenters level and shim legs accordingly. Case must be raised correctly, under legs where support is best, to prevent damage to case.

1. Check level of floor where cases are to be set. Determine the highest point of the floor; cases will be set off this point.
2. Set first case, and adjust legs over the highest part of the floor so that case is level. Prevent damage - case must be raised under leg or by use of 2x6 or 2x4 leg brace. Remove side and back leg braces after case is set.
3. Set second case as close as possible to the first case and level case to the first using the instructions in step one.
4. Apply masking tape 1/8" in from end of case on inside and outside rear mullion on both cases to be joined.
5. Apply liberal bead of case joint sealant (butyl) to (dotted area shown in figure) first case. Apply heavy amount to cover entire shaded area.

DO NOT USE PERMAGUM!



6. Slide second case up to first case snugly. Then level second case to the first case so glass front, bumper and top are flush.

Installation (Cont'd)

7. To compress silicone at joint, use two Jurgenson wood clamps. Make sure case is level from front to back and side to side on inside bulkheads at joint.
8. Attach sections together via a 2 bolts located in the base of the case. Secure the overhead structure by bolting the bracket, located inside behind lights.
9. Apply bead of silicone to top of bulkheads and slip on stainless steel bulkhead cap. Also apply silicone to seam between overhead light tubes.
10. Use finger to smooth silicone as thin as possible at masking tape on inside and outside of rear mullion (apply additional silicone if necessary). Remove tape applied on line #3.

Corner Wedges

Corner wedges are attached via front and rear camlocks. Use a 7mm allen wrench to turn the locks. Do not over-tighten! Join the top by using a joint bracket (included in joint kit) with 3/8" bolts.

Joint Trim

After cases have been leveled and joined, and refrigeration, electrical, and wasted piping work completed, install the splashguards. Fasten along the top edge, or center, with #10 X 3/3" sheet metal screws.

DO NOT SEAL JOINT TRIM TO FLOOR!

Scale Stand Installation Instructions



1.- Set Scale Stand to desire location



2.- Drill holes and screw in place
(with screws provided – Hex Tek S/S
10-16 X 1/2")



Note: Use hole pattern

Installation (Cont'd)

Wrapping Boards Installation Instructions

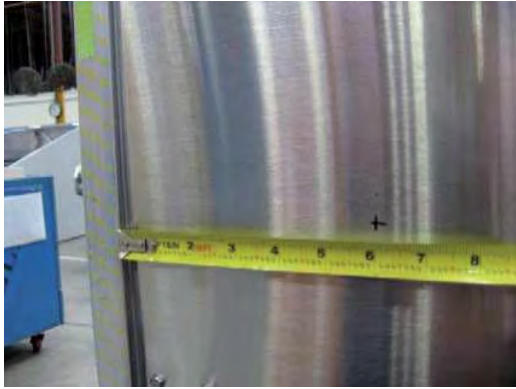

Step 1: Measure 6 inches from wrapping board end.



Step 2: Measure 10 inches from top of the case.

Note: Line up 6 inch mark with 10 inch mark.



Step 3: Use bracket center hole to align with cross mark.

Note: Use pencil/marker to mark hole pattern.



HOLE PATTERN

Step 4: Drill holes (7/32")

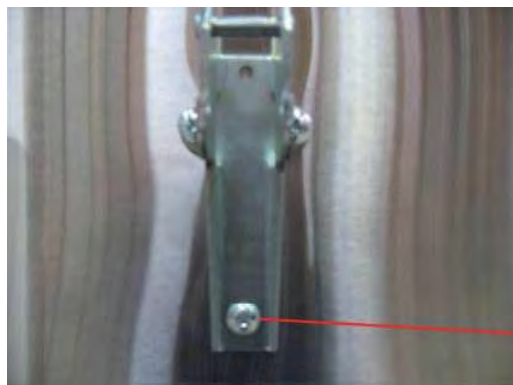

Step 5: Install bracket with screws (provided)

Note: Repeat Steps 1 Thru 5 for Second Bracket Installation.

Installation (Cont'd)



Step 6: Install upper support bracket



Step 7: Mount wrap board on top of bracket using a 1/4" spacer to have a gap between rear wall and board.



Step 8: screw bracket into wrap board (screws provided -#8 X 1 1/4")



Installation Complete

Installation (Cont'd)

Bumper Installation Instructions



Step 1: Make sure the aluminum channel and end caps are installed.



Step 2: Use silicone lubricant to help the bumper slide into the channel.



Step 3: Starting on one end: while inserting the bumper, push it up against the end cap to prevent the bumper from shrinking after installation (when it gets cold).



Step 4: As you insert the bumper into the channel with one hand, pull the bumper toward you with the other to open the inside lips. Slowly apply pressure by rolling the bumper into the track.

5. Plumbing

Waste Outlet and P-TRAP

The waste outlet is located off the center of the case on one side allowing drip piping to be run lengthwise under the fixture. There are 2 drains in each fixture that can be easily located.

P-traps must be installed at the base of all refrigerated cases. The 1 1/2" P-TRAPS and threaded adapters must be installed to prevent air leakage and insect entrance into the fixture.

Installing Condensate Drain

Poorly or improperly installed condensate drains can seriously interfere with the operation of this refrigerator, and result in costly maintenance and product losses. Please follow the recommendations listed below when installing condensate drains to insure a proper installation:

1. Never use pipe for condensate drains smaller than the nominal diameter of the pipe or P-TRAP supplied with the case.
2. When connecting condensate drains, the P-TRAP must be used as part of the condensate drain to prevent air leakage or insect entrance. Store plumbing system floor drains should be at least 14" off the center of the case to allow use of the P-TRAP pipe section. Never use two water seals in series in any one line. Double P-TRAPS in series will cause a lock and prevent draining.
3. Always provide as much down hill slope ("fall") as possible; 1/8" per foot is the preferred minimum. PVC pipe, when used, must be supported to maintain the 1/8" pitch and to prevent warping.
4. Avoid long runs of condensate drains. Long runs make it impossible to provide the "fall" necessary for good drainage.
5. Provide a suitable air break between the flood rim of the floor drain and outlet of condensate drain. 1" is ideal.
6. Prevent condensate drains from freezing:
 - a. Do not install condensate drains in contact with non-insulated suction lines. Suction lines should be insulated with a non - absorbent insulation material such as Armstrong's Armaflex.
 - b. Where condensate drains are located in dead air spaces (between refrigerators or between a refrigerator and a wall), provide means to prevent freezing. The water seal should be insulated to prevent condensation.

6. Refrigeration

Refrigerant Type

The standard refrigerant will be R-404A unless otherwise specified on the customer order. Check the serial plate on the case for information.

Piping

The refrigerant line outlets are located under the case. Locate first the electrical box, the outlets are then on the same side of the case but at the opposite end. Insulate suction lines to prevent condensation drippage.

Refrigeration Lines

<u>Liquid</u>	<u>Suction</u>
3/8" O.D.	5/8" O.D.

NOTE: The standard coil is piped at 5/8" (suction); however, the store tie-in may vary depending on the number of coils and the draw the case has. Depending on the case setup, the connecting point in the store may be 5/8", 7/8", or 1 1/8". Refer to the particular case you are hooking up.

Refrigerant lines should be sized as shown on the refrigeration legend furnished by the store.

Oil traps must be installed at the base of all suction line vertical risers on refrigerated cases.

Pressure drop can rob the system of capacity. To keep the pressure drop to a minimum, keep refrigerant line run as short as possible, using the minimum number of elbows. Where elbows are required, use long radius elbows only.

Control Settings

Maintain these parameters to achieve near constant product temperatures. Product temperature should be measured first thing in the morning, after having been refrigerated overnight. Defrost times should be as follows: OFF CYCLE - The number of defrosts per day and the duration of the defrost cycle may be adjusted to meet conditions present at your location.

Refrigeration (Cont'd)

Access to TX Valves and Drain Lines

Mechanical - Remove product from end of case. Remove product racks. Remove refrigeration and drain access panels (labeled). TX valve (mechanical only) and drain are located under each access panel at end of the case.

Electronic - The Electronic Expansion valve master and slave cylinder(s) are located within the electrical access panel(s).

Electronic Expansion Valve (Optional)

A wide variety of electronic expansion valves and case controllers can be utilized. Please refer to EEV and controller manufacturers information sheet. Sensors for electronic expansion valves will be installed on the coil inlet, coil outlet, and in the discharge air. (Some supermarkets require a 4th sensor in the return air). Case controllers will be located in the electrical raceway or under the case. The front Self Service Evaporator has an EPR valve installed to maintain a constant discharge temperature. It is located in the front at the right side of the case under the fan plenum near the TX valve.

Thermostatic Expansion Valve Location

This device is located on the same side as the refrigeration stub. A Sporlan balanced port expansion valve model is furnished as standard equipment, unless otherwise specified by customer.

Expansion Valve Adjustment

Expansion valves must be adjusted to fully feed the evaporator. Before attempting any adjustments, make sure the evaporator is either clear or very lightly covered with frost, and that the fixture is within 10°F of its expected operating temperature.

Measuring the Operating Superheat

1. Determine the suction pressure with an accurate pressure gauge at the evaporator outlet.
2. From a refrigerant pressure temperature chart, determine the saturation temperature at the observed suction pressure.
3. Measure the temperature of the suction gas at the thermostatic remote bulb location.
4. Subtract the saturation temperature obtained in step No. from the temperature measured in step No. 3. The difference is superheat.
5. Set the superheat for 5°F - 7°F.

Evaporator Pressure Regulator

An Evaporator Pressure Regulator is installed in the front of the self service section to maintain a constant discharge temperature. It is located at the front right side of the case, under the fan plenum near the TX Valve.

Service Case Temperature Control

Temperature control in the upper section of the R3 with the Service Option is done by means of a thermostat and suction solenoid valve. This controls both temperature and humidity.

T-STAT Location

T-STATS are located within the electrical raceway. Refer to diagram below.

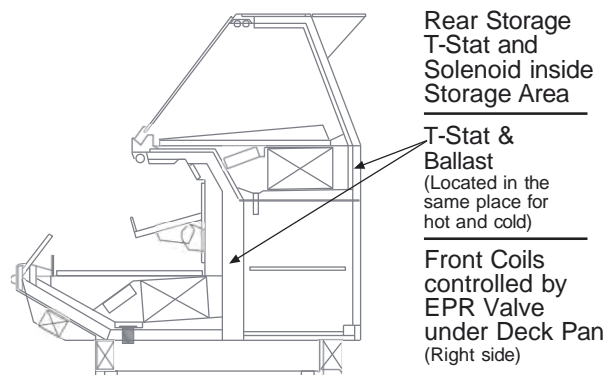

WARNING!
Do NOT apply thread sealer to ABS P-Trap.





DELI SERVICE - SELF SERVICE
 HUSSMANN - R3D & B/CR3D & B SH, +2H, & +4H OPTIONS (CHINO)

REVISION DATE 01/11/18



Hussmann refrigerated merchandisers configured for sale for use in the United States meet or surpass the requirements of the DOE 2017 energy efficiency standards.

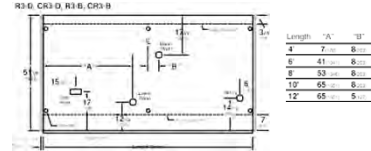
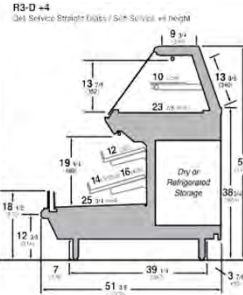
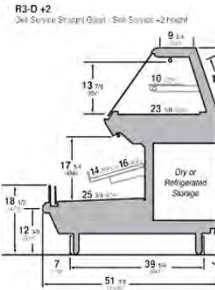
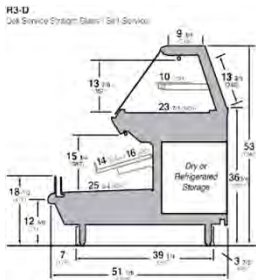

REFRIGERATION DATA:

CASE LENGTHS/ %EDGES	CASE USAGE	CAPACITY TOP/FRONT (BTU/HR/FT)		TEMPERATURE (F)			DISCHARGE AIR VELOCITY (FT/MIN)
		RATING CONDITION		EVAPORATOR		DISCHARGE AIR TEMP	
		NSF +	AHRI *2,1	NSF +	AHRI *2,1	NSF +	NSF +
4'x5'x6' & 8'x10'x12'	DELI / BA(ER#)	250 / 600	160 / 540	20	24	TO 26 *RONT 30	TO 1500175 *RONT 1750200
4'x5'x6' & 8'x10'x12'	REAR STORAGE	110	90	20	26	32034	3800600

CASE LENGTH H	EST/ REFG/ CHRG((4,4A) (LBS)	2, °F GLICOL - ° RISE TOP		2, °F GLICOL - ° RISE FRONT		2, °F GLICOL - ° RISE REAR STORAGE	
		GPM	PSI	GPM	PSI	GPM	PSI
		4'	1.0	0.4	0.7	1.1	2.2
5'	1.3	0.4	1.3	1.3	3.4	0.2	0.2
6'	1.5	0.5	2.0	1.5	4.9	0.2	0.3
8'	2.1	0.7	3.7	2.0	2.4	0.3	0.5
10'	2.7	0.8	6.0	2.5	4.1	0.4	0.8
12'	3.2	1.0	8.7	3.0	4.8	0.5	1.1

FRONT DISCHARGE AIR MEASURED INSIDE AIR CURTAIN HONEYCOMB

REFRIGERATION NOTES:

- 1) BTU'S INCLUDE 3 ROWS (2 TO 1 1 *RONT) CANO # LED LIS%TS AND NO S%EL' LIS%TS
- 2) ADD 10 BTU'S ER *OOT/ ER S%EL' *OR O TIONAL LED S%EL' LIS%TS
- 3) 2% O TION! ADD 30 BTU%/R/T *OR T%E *RONT& ADD 5 BTU%/R/T *OR T%E REAR STORAGE.
- 4) 4% O TION! ADD 110 BTU%/R/T *OR T%E *RONT& ADD 10 BTU%/R/T *OR T%E REAR STORAGE.
- 5) A%RI 1200 RATIN\$ OINT *OR ENER\$# CONSU' TION C O' ARISON ONL#
- 6) USE DEW OINT *OR %S% SLIDE RE'RISERANTS. CARE S%OULD BE TA(EN TO USE T%E DEW OINT IN /T TABLES *OR 'EASURIN\$ AND ADJUSTIN\$ SU ER%EAT. ADJUST EVA ORATOR RESSURE AS NEEDED TO 'AINTAIN T%E DISC*AR\$E AIR TE' ERATURE S%OWN.
- 7) RATIN\$ CONDITION IS NS' T' E & 75**/55+ R%

REFRIGERATION DATA CONTINUED:

ELEC(THERMOSTAT / AIR SENSOR SETTINGS			DEFROST OST TIPE	TIME (MIN)	DEFROST FRE(UENC! (\$/DA1)	TERM(TEMP (*F) COIL ONL!	DRIP TIME	DEFROST %ATER (LBS/DA/FT)	FAN BLADE DIA(FAN BLADE PITCH
USAGE	CUT IN (F)	CUT OUT (F)								
TO	29	26	O** TI'E	30	4	45	N/A	0.34	6.75,	NO S%EL"- '3' . 4'/10"1 5' /15" W S%EL"- 15"
*RONT	31	28				48	N/A	2.8	6.75,	3' . 4'-15" ! 5'- 20"
REAR STORAGE	37	36				45	N/A	0.15	6.75,	30"

ELECTRICAL DATA:

STANDARD FANS, HEATERS, LED LIGHTS (** VOLT)

CASE LENGTH	TOTAL EVAPORATOR FANS			CANOPI LIGHTS LED TOP & FRONT		OPTIONAL LED SHELF LIGHTS (FRONT AND TOP)		OPTIONAL LED 2ND SHELF (FRONT) +2H & +4H ONLI		MA.(LED LOAD (%/ ALL OPTIONS)		ANTI-S%EAT HEATERS		REFRIGERATED REAR STORAGE (OPTIONAL) EVAP FANS		CONVENIENCE OUTLETS (OPTIONAL)			
	\$ OF EVAP FANS	AMPS	%ATTS	AMPS	%ATTS	AMPS	%ATTS	AMPS	%ATTS	AMPS	%ATTS	AMPS	%ATTS	\$ OF EVAP FANS	AMPS	%ATTS	\$ OUTLE TS	VOLTS	AMPS
4'	3	0.4	24	0.3	31	0.2	21	0.1	10	0.5	62	0.8	97	1	0.3	8.8	1	115	15
5'	3	0.4	24	0.3	39	0.2	26	0.1	13	0.7	78	1.1	122	1	0.3	8.8	1	115	15
6'	5	0.6	40	0.4	46	0.3	31	0.1	15	0.8	93	1.3	147	1	0.3	8.8	1	115	15
8'	6	0.7	48	0.5	62	0.4	41	0.2	21	1.1	124	1.7	197	1	0.3	8.8	1	115	15
10'	6	0.7	48	0.7	78	0.5	52	0.2	26	1.4	156	2.1	247	1	0.3	8.8	1	115	15
12'	9	1.1	72	0.8	93	0.5	62	0.3	31	1.6	185	2.6	297	1	0.3	8.8	2	115	30

OPTIONAL HIGH OUTPUT LED LIGHTS (** VOLT)

CASE LENGTH	CANOPI LIGHTS H(O) LED TOP & FRONT		OPTIONAL SHELF (FRONT AND TOP)		OPTIONAL 2ND SHELF (FRONT) +2H & +4H ONLI		MA.(H(O) LED LOAD	
	AMPS	%ATTS	AMPS	%ATTS	AMPS	%ATTS	AMPS	%ATTS
4'	0.4	46	0.1	15	0.1	15	0.7	76
5'	N/A	N/A	N/A	N/A	N/A	N/A	N/A	N/A
6'	0.7	78	0.2	26	0.2	26	1.1	130
8'	0.8	91	0.3	30	0.3	30	1.3	152
10'	N/A	N/A	N/A	N/A	N/A	N/A	N/A	N/A
12'	1.2	137	0.4	46	0.4	46	2.0	228

END PANEL %IDTH & E!

\$ OF END PNLS	EN D PNL %IDTH (IN)	TOTAL ADDED LENGTH (IN)
1	1.125	1.125
2	1.125	2.25



DELI SERVICE - TOP ONLY

HUSSMANN - R3TO (CHINO)

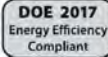

Hussmann refrigerated merchandisers configured for sale for use in the United States meet or surpass the requirements of the DOE 2017 energy efficiency standards.

REVISION DATE

1/4/17



R3TO

Refrigerated Drop-In Counter

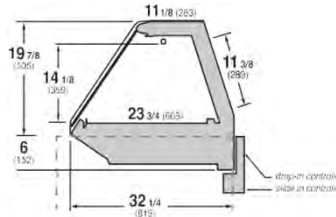

CR3TO

Refrigerated Drop-In Counter-Curved Glass

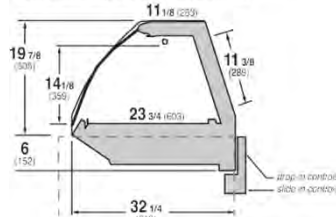

R3TO / CR3TO Plan View

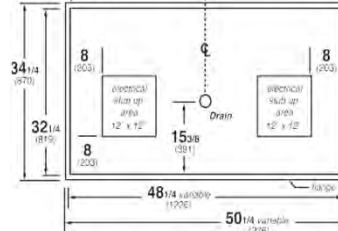

REFRIGERATION DATA:

CASE LENGTHS	CASE USAGE	CAPACITY *** (BTU/HR/FT)		TEMPERATURE (°F)			VELOCITY (FT/MIN)
		RATING CONDITION		EVAPORATOR		DISCHARGE AIR ** (°F)	
		NSF 7	AHRI 1200	NSF 7	AHRI 1200	NSF 7	
4'-5'6" (1219)	DEL	25	22	25	22	25-27	150-200

**FRONT DISCHARGE AIR MEASURED INSIDE AIR CURTAIN HONEYCOMB

***REFRIGERATION NOTES:

- 1) BTU'S INCLUDE CANOPY LIGHTS. ADD 10 BTUS/SHELF/FT FOR EACH SHELF (LIGHT)
- 2) AHRI 1200 RATING POINT FOR ENERGY CONSUMPTION COMPARISON ONLY
- 3) USE DEW POINT FOR HIGH GLIDE REFRIGERANTS. CARE SHOULD BE TAKEN TO USE THE DEW POINT IN P/T TABLES FOR MEASURING AND ADJUSTING SUPERHEAT. ADJUST EVAPORATOR PRESSURE AS NEEDED TO MAINTAIN THE DISCHARGE AIR TEMPERATURE SHOWN.
- 4) RATING CONDITION IS NSF TYPE I, 75°F/55% RH

CASE LENGTHS	EST. REFG - CHRGR - 404A (LBS)	GLYCOL (20°F INLET, 6° RISE)	
		GPM	PSI
4'	0.5	0.4	0.5
5'	0.6	0.5	0.9
6'	0.8	0.5	1.4
8'	1.1	0.7	0.6
12'	1.7	1.0	1.4

REFRIGERATION DATA CONTINUED:

ELEC. THERMOSTAT / AIR SENSOR SETTINGS			DEFROST TYPE	TIME (MIN)	DEFROST FREQUENCY (#/DAY)	TERM. TEMP (°F) COIL ONLY	DRI P TIME	DEFROST WATER (LBS/DAY/FT)
USAGE	CUT IN (°F)	CUT OUT (°F)						
DEL	25	22	OFF TIME	40	4	45	N/A	0.3

END PANEL WIDTH KEY		
# OF END PNLS	END PNL WIDTH (IN.)	TOTAL ADDED LENGTH (IN.)
1	1.125	1.125
2	1.125	2.25

ELECTRICAL DATA:

STANDARD FANS, HEATERS, LED LIGHTS (115 VOLT)

CASE LENGTH	EVAPORATOR FANS				CANOPY LIGHTS LED		OPTIONAL LED SHELF LIGHTS		MAX. LED LOAD (W/ ALL OPTIONS)		ANTI-SWEAT HEATERS (ON FAN CIRCUIT)		CONVENIENCE OUTLETS (OPTIONAL)			
	# OF EVAP FANS	BLADE DIA. (IN.)	BLADE PITCH (°)	AMPS	WATTS	AMPS	WATTS	AMPS	WATTS	AMPS	WATTS	AMPS	WATTS	# OUTLETS	VOLTS	AMPS
4'	2	6.7	10	0.2	16	0.1	10	0.1	10	0.2	21	N/A	N/A	N/A	N/A	N/A
5'	2	6.7	15	0.2	16	0.1	13	0.1	13	0.2	26	N/A	N/A	N/A	N/A	N/A
6'	2	6.7	10	0.2	16	0.1	15	0.1	15	0.3	31	N/A	N/A	N/A	N/A	N/A
8'	2	6.7	10	0.5	32	0.2	21	0.2	21	0.3	31	N/A	N/A	N/A	N/A	N/A
12'	6	6.7	10	0.7	50	0.3	31	0.3	31	0.3	31	N/A	N/A	N/A	N/A	N/A
CASE LENGTH	CANOPY LIGHTS H.O. LED		OPTIONAL SHELF LED		LED LOAD											
	AMPS	WATTS	AMPS	WATTS	AMPS	WATTS										
4'	0.1	15	0.1	15	0.3	30										
5'	N/A	N/A	N/A	N/A	N/A	N/A										
6'	N/A	N/A	N/A	N/A	N/A	N/A										
8'	0.3	30	0.3	30	0.5	61										
12'	0.4	46	0.4	46	0.8	91										



DELI SERVICE - SELF SERVICE
 RUSSMANN - R3P/CR3P SH, +2H, & +4H OPTIONS (CHINA)

REVISION DATE 11/01/18



Russmann refrigerated merchandisers configured for sale for use in the United States meet or surpass the requirements of the DOE 2017 energy efficiency standards.

R3P
 Prep Service Straight Glass / Self Service

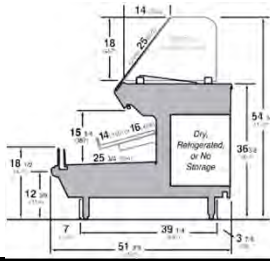

CR3P
 Prep Service Straight Glass / Self Service

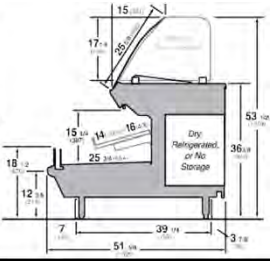

R3/CR3-P

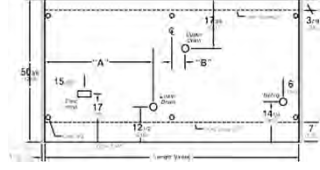

Length	"A"	"B"
4'	7'-11/16"	8'-0"
5'	35'-0"	5'-11/16"
6'	41'-11/16"	8'-0"
8'	53'-11/16"	8'-0"
10'	65'-11/16"	8'-0"
12'	65'-11/16"	5'-0"



REFRIGERATION DATA:

CASE LENGTHS	CASE USAGE	CAPACIT# TOP/FRONT (STU/HR/FT)		TEMPERATURE (F)			VELOCIT# TOP/FRONT (FT/MIN)
		RATING CONDITION		EVAPORATOR TOP/FRONT		DISCHARGE AIR TOP/FRONT**	
		NSF	AHRI 2 !!!	NSF	AHRI 2 !!!	NSF	
4'5"6"	DELI / BA)ER!	250 / 650	N/A / 540	20 / 22	N/A / 24	26 / 32	100-150 / 175-200
4'5"6"	(EAT)	250 / 750	N/A / 540	20 / 20	N/A / 24	26 / 24	100-150 / 225-275
REAR STORA*E	DELI / BA)ER!	110	90	20	26	30-34	380-600

CASE LENGTHS	EST. REFG* CHRGR* 4140 (LSS)	21) F GL#COL /) RISE INLET TOP		21) F GL#COL /) RISE INLET FRONT		21) GL#COL /) RISE INLET OPTION REFRIGERATED REAR STORAGE	
		GPM	PSI	GPM	PSI	GPM	PSI
		4'	1.0	0.4	8.0	0.9	2.3
5'	1.2	0.4	12.8	1.1	3.7	0.2	0.1
6'	1.4	0.5	4.2	1.3	5.3	0.2	0.2
8'	1.8	0.7	7.9	1.8	2.4	0.3	0.5
10'	2.4	0.8	12.5	2.2	4.2	0.4	0.7
12'	2.7	1.0	7.9	2.6	5.0	0.4	0.9

**FRONT DISCHARGE AIR MEASURED INSIDE AIR CURTAIN HONE#COMS
 ***REFRIGERATION NOTES:

- 1) BTUS INCLUDE 1 ROW (SERVICE SECTION) CANO ! LED LI*#TS AND NO S#EL\$ LI*#TS
- 2) ADD 10 BTUS ER \$OOT/ ER S#EL\$ ROW \$OR O TIONAL LED S#EL\$ LI*#TS
- 3) %2# O TION& SUBTRACT 15 BTU/#R/\$T \$OR T#E \$RONT
- 4) 2# O TION& ADD 30 BTU/#R/\$T \$OR T#E \$RONT' ADD 5 BTU/#R/\$T \$OR T#E REAR STORA*E
- 4# O TION& ADD 110 O TION BTU/#R/\$T \$OR T#E \$RONT' ADD 10 BTU/#R/\$T \$OR T#E REAR STORA*E
- 5) A#R1 1200 RATIN* OINT \$OR ENER*1 CONSU TION CO (ARISON ONL!
- 7) USE DEW OINT \$OR #1*# *LIDE RESRI*ERANTS. CARE S#OULD BE TA)EN TO USE T#E DEW OINT IN /T TABLES \$OR (EASURIN* AND AD*USTIN* SU ER#EAT. AD*UST EVA ORATOR RESSURE AS NEEDED TO (AINTAIN T#E DIS#AR*E AIR T#E (ERATURES S#OWN.
- 8) RATIN* CONDITION IS NSS T! E I 75+\$/55, R#

REFRIGERATION DATA CONTINUED:

LOCATION	ELEC THERMOSTAT / AIR SENSOR SETTINGS		DEFROST T#PE	TIME (MIN)	DEFROSTS PER DA#	TERM TEMP (F) COIL ONL#	DRIP TIME	DEFROST %ATER (LSS/DA#/FT)
	USAGE	CUT N (F)						
TO	DELI	29	26	OSS T! (E	40	4	NA	45
\$RONT	DELI	31	28					48
\$RONT	(EAT)	26	22					48
RESRI*ERATED REAR STORA*E	DELI	31	28					48

END PANEL %IDTH &#		
(OF END PNLS	END PNL %IDTH (IN)	TOTAL ADDED LENGTH (IN)
1	1.125	1.125
2	1.125	2.25

ELECTRICAL DATA:

STANDARD FANS, HEATERS, LED LIGHTS (' VOLT)

CASE LENGTH	TOTAL EVAPORATOR FANS (INCLUDING CONDIMENT RAIL)				REFRIGERATED REAR STORAGE EVAP FANS (OPTIONAL)				CANOP# LIGHTS LED (SERVICE SECTION)		OPTIONAL LED SHELF LIGHTS (SERVICE SECTION)		OPTIONAL LED 2+ SHELF (SERVICE SECTION) +2H & +4H ONL#		MA-* LED LOAD (% ALL OPTIONS)		ANTI-S#EAT HEATERS	
	(OF EVAP FANS (TOP/FRONT))	FAN SLADE PITCH (FRONT))	AMPS	%ATTS	(OF EVAP FANS	AMPS	%ATTS	AMPS	%ATTS	AMPS	%ATTS	AMPS	%ATTS	AMPS	%ATTS	AMPS	%ATTS	
4	2 / 2	15	0.4	32	1	0.3	8.8	0.1	10	0.1	10	0.1	10	0.3	31	0.2	23	
5	2 / 2	20	0.4	32	1	0.3	8.8	0.1	13	0.1	13	0.1	13	0.3	39	0.2	29	
6	4 / 3	15	0.8	56	1	0.3	8.8	0.1	15	0.1	15	0.1	15	0.4	46	0.3	34	
8	4 / 4	15	0.9	64	1	0.3	8.8	0.2	21	0.2	21	0.2	21	0.5	62	0.4	46	
10	4 / 4	20	0.9	64	1	0.3	8.8	0.2	26	0.2	26	0.2	26	0.7	78	0.5	57	
12	6 / 6	15	1.3	96	1	0.3	8.8	0.3	31	0.3	31	0.3	31	0.8	93	0.6	68	

OPTIONAL HIGH OUTPUT LED LIGHTS (' VOLT)

CASE LENGTH	CANOP# LIGHTS H*O LED (SERVICE SECTION)		OPTIONAL SHELF (SERVICE SECTION)		OPTIONAL SHELF (SERVICE SECTION) +2H & +4H ONL#		MA-* H*O LED LOAD	
	AMPS	%ATTS	AMPS	%ATTS	AMPS	%ATTS	AMPS	%ATTS
4	0.1	15	0.1	15	0.1	15	0.4	46
5	N/A	N/A	N/A	N/A	N/A	N/A	N/A	N/A
6	N/A	N/A	N/A	N/A	N/A	N/A	N/A	N/A
8	0.3	30	0.3	30	0.3	30	0.6	51
10	N/A	N/A	N/A	N/A	N/A	N/A	N/A	N/A
12	0.4	46	0.4	46	0.4	46	1.2	137

CONVENIENCE OUTLETS (OPTIONAL)		
(OUTLETS	VOLTS	AMPS
1	115	15
1	115	15
1	115	15
1	115	15
2	115	30

7. Electrical

Wiring Color Code

STANDARD CASE WIRE COLOR CODE CODIGO DE COLORES DE LOS ALAMBRES PARA LAS VITRINAS ESTANDAR CODE COULER POUR FILS DE BOITIER NORMALISE		
COLOR DESCRIPTION	DESCRIPCION	DESCRIPTION
GROUND	TIERRA MASA	MASSE
ANTI-SWEAT	ANTICONDENSACION	ANTI-SUITEMENT
LIGHTS	LUCES	ECLAIRAGE
RECEPTACLES	ENCHUFES	PRISE DE COURANT
T-STAT/SOLENOID 230VAC	TERMOSTATO/SOLENOIDE (230VAC)	SOUPAPE A SOLENOID (230 VAC)
T-STAT/SOLENOID 115VAC	TERMOSTATO/SOLENOIDE (115VAC)	SOUPAPE A SOLENOID (115 VAC)
T-STAT/SOLENOID 24VAC	TERMOSTATO/SOLENOIDE (24VAC)	SOUPAPE A SOLENOID (24 VAC)
FAN MOTORS	VENTILADORES	VENTILATEUR
BLUE CONDENSING UNIT	UNIDAD DE CONDENSACION	UNITE DE CONDENSATION

USE COPPER CONDUCTORS ONLY
UTILISEZ LES CONDUCTEURS DE CUIVRE SEULEMENT
UTILICE LOS CONDUCTORES DE COBRE SOLAMENTE
430-01-0338 R101003

CASE MUST BE GROUNDED

NOTE: Refer to label affixed to case to determine the actual configuration as checked in the “TYPE INSTALLED” boxes.

Electrical Circuit Identification

Standard lighting for all refrigerated models will be full length fluorescent lamps located within the case at the top.

The switch controlling the lights, the plug provided for digital scale, and the thermometer are located at the rear of the case mullion.

The receptacle that is provided on the exterior back of these models is intended for computerized scales with a five amp maximum load, not for large motors or other high wattage appliances. It should be wired to a dedicated circuit.

Electrical Service Receptacles (When Applicable)

The receptacles located on the exterior of the merchandiser are intended for scales and lighted displays. They are not intended nor suitable for large motors or other external appliances.



DANGER

**BEFORE SERVICING
ALWAYS DISCONNECT ELECTRICAL
POWER AT THE MAIN DISCONNECT
WHEN SERVICING OR REPLACING ANY
ELECTRICAL COMPONENT.**
This includes (but not limited to) Fans, Heaters
Thermostats, and Lights.

Field Wiring and Serial Plate Amperage

Field Wiring must be sized for component amperes printed on the serial plate. Actual ampere draw may be less than specified. Field wiring from the refrigeration control panel to the merchandisers is required for refrigeration thermostats. Case amperes are listed on the wiring diagram, but always check the serial plate.

LED Driver Location

Drivers are located within the access panel that runs the length of the rear of the case.

8. User Information

Stocking

Improper temperature and lighting will cause serious product loss. Discoloration, dehydration and spoilage can be controlled with proper use of the equipment and handling of product. Product temperature should always be maintained at a constant and proper temperature. This means that from the time the product is received, through storage, preparation and display, the temperature of the product must be controlled to maximize life of the product. Hussmann cases were not designed to “heat up” or “cool down” product - but rather to maintain an item’s proper temperature for maximum shelf life. To achieve the protection required always:

1. Minimize processing time to avoid damaging temperature rise to the product. Product should be at proper temperature.
2. Keep the air in and around the case area free of foreign gasses and fumes or food will rapidly deteriorate.
3. Maintain the display merchandisers temperature controls as outlined in the refrigerator section of this manual.
4. Do not place any product into these refrigerators until all controls have been adjusted and they are operating at the proper temperature. Allow merchandiser to operate a minimum of 6 hours before stocking with any product.
5. When stocking, never allow the product to extend beyond the recommended load limit. Air discharge and return air flow must be unobstructed at all times to provide proper refrigeration.
6. Keep the service doors closed (when applicable). Refrigeration performance will be seriously affected if left open for a prolonged period of time.
7. Avoid the use of supplemental flood or spot lighting. Display light intensity has been designed for maximum visibility and product life at the factory. The use of higher output fluorescent lamps (H.O. and V.H.O.), will shorten the shelf life of the product.

Cleaning Glass and Mirrors

Only use a soft cloth and mild glass cleaning for cleaning any glass or mirrored components. Be sure to rinse and/or dry completely.

Never use hot water on cold glass surfaces! It may shatter and cause serious injury! Allow glass surfaces to warm first.



IMPORTANT INFORMATION

FOR PROMPT SERVICE

**When Contacting the Factory regarding problems.
Be sure to have the Case MODEL and
SERIAL NUMBER Handy. This Information
is on a plate located on the case itself.**

User Information (Cont'd)

Non-glare Glass

Windex® or Glass Plus® are the only solutions recommended to be used to clean the non-glare glass. The damage to the glass from improper, caustic solutions is irreparable.

In addition to cleaning the glass with the recommended product, there are precautions that should be taken when working and cleaning the inside of the case.

- When cleaning the inside of the cases, we recommend that the glass be fully opened and covered to prevent to prevent solutions from splashing onto the glass and ruining the coating on the inside.

Plexiglass and Acrylic Care

Improper cleaning not only accelerates the cleaning cycle but also degrades the quality of this surface. Normal daily buffing motions can generate static cling attracting dust to the surface. Incorrect cleaning agents or cleaning cloths can cause micro scratching of the surface, causing the plastic to haze over time.

Cleaning

Hussmann recommends using a clean damp chamois, or a paper towel marketed as dust and abrasive free with **210® Plastic Cleaner and Polish** available by calling Sumner Labs at **1-800-542-8656**. Hard, rough cloths or paper towels will scratch the acrylic and should not be used.

Antistatic Coatings

The 210® has proven to be very effective in not only cleaning and polishing the Plexiglass surface, but also providing antistatic and anti-fog capabilities. This product also seals pores and provides a protective coating.

CAUTION

CLEANING PRECAUTIONS

When cleaning:

- Do not use high pressure water hoses
- Do not introduce water faster than waste outlet can drain
- NEVER INTRODUCE WATER ON SELF CONTAINED UNIT WITH AN EVAPORATOR PAN
- NEVER USE A CLEANING OR SANITIZING SOLUTION THAT HAS AN OIL BASE (these will dissolve the butyl sealants) or an AMMONIA BASE (this will corrode the copper components of the case)
- TO PRESERVE THE ATTRACTIVE FINISH:
- DO USE WATER AND A MILD DETERGENT FOR THE EXTERIOR ONLY
- DO NOT USE A CHLORANITED CLEANER ON ANY SURFACE
- DO NOT USE ABRASIVES OR STEEL WOOL SCOURING PADS (these will mar the finish)

Evaporator Fans

The evaporator fans are located at the center front of these *merchandisers directly beneath the display pans*. *Should fans or blades need servicing, always replace fan blades with the raised embossed side of the blade TOWARD THE MOTOR.*

Copper Coils

The copper coils used in Hussmann merchandisers may be repaired in the field. Materials are available from local refrigeration wholesalers.

Hussmann recommends using #15 Sil-Fos for repairs.

Tips and Troubleshooting

Before calling for service, check the following:

1. Check electrical power supply to the equipment for connection.
2. Check fixture loading. Overstocking case will affect its proper operation.
3. If frost is collecting on fixture and/or product, check that no outside doors or windows are open - allowing moisture to enter store. These merchandisers were designed for use in stores where temperature & humidity does not exceed 75° F and 55% H.

Stainless Steel Cleaning and Care

There are three basic things, which can break down your stainless steel's passivity layer and allow corrosion.

1. Mechanical Abrasion

Mechanical Abrasion means those things that will scratch the steel's surface. Steel Pads, wire Brushes, and Scrapers are prime examples.

2. Water

Water comes out of our tap in varying degrees of hardness. Depending on what part of the country you live in, you may have hard or soft water. Hard water may leave spots. Also, when heated, hard water leaves deposits behind that if left to sit, will break down the passive layer and rust your stainless steel. Other deposits from food preparation and service must be properly removed.

3. Chlorides

Chlorides are found nearly everywhere. They are in water, food and table salt. One of the worst perpetrators of chlorides can come from household and industrial cleaners.

Don't Despair! Here are a few steps that can help prevent stainless steel rust.

1. Use the Proper Tools

When cleaning your stainless steel products, take care to use non-abrasive tools. Soft Clothes and plastic scouring pads will NOT harm the steel's

User Information (Cont'd)

passive layer. Stainless steel pads can also be used but the scrubbing motion must be in the same direction of the manufacturer's polishing marks.

2. Clean With the Polish Lines

Some stainless steels come with visible polishing lines or "grain". When visible lines are present, you should ALWAYS scrub in a motion that is parallel to them. When the grain cannot be seen, play it safe and use a soft cloth or plastic scouring pad.

3. Use Alkaline, Alkaline Chlorinated or Non-chloride Containing Cleaners

While many traditional cleaners are loaded with chlorides, the industry is providing an ever increasing choice of non-chloride cleaners. If you are not sure of your cleaner's chloride content contact your cleaner supplier. If they tell you that your present cleaner contains chlorides, ask for an alternative. Also, avoid cleaners containing quaternary salts as they also can attack stainless steel & cause pitting and rusting.

4. Treat your Water

Though this is not always practical, softening hard water can do much to reduce deposits. There are certain filters that can be installed to remove

distasteful and corrosive elements. Salts in a properly maintained water softener are your friends. If you are not sure of the proper water treatment, call a treatment specialist.

5. Keep your Food Equipment Clean

Use alkaline, alkaline chlorinated or non-chlorinated cleaners at recommended strength. Clean frequently to avoid build-up of hard, stubborn stains. If you boil water in your stainless steel equipment, remember the single most likely cause of damage is chlorides in the water. Heating cleaners that contain chlorides has a similar effect.

6. RINSE, RINSE, RINSE

If chlorinated cleaners are used you must rinse, rinse, rinse and wipe dry immediately. The sooner you wipe off standing water, especially when it contains cleaning agents, the better. After wiping the equipment down, allow it to air dry for the oxygen helps maintain the stainless steel's passivity film.

7. Never Use Hydrochloric Acid (Muriatic Acid) on Stainless Steel

8. Regularly Restore/Passivate Stainless Steel

9. Shelf Weight Limits

Depth of Shelf	Maximum Load Limit
10 in (254 mm)	250 lb (113.4 kg)
12 in (305 mm)	250 lb (113.4 kg)
14 in (356 mm)	250 lb (113.4 kg)
16 in (407 mm)	250 lb (113.4 kg)
18 in (457 mm)	250 lb (113.4 kg)

* Shelf load limits at 0° tilt

Hussmann® merchandiser shelves are designed to support the maximum weight load limits as indicated in the table above. Exceeding these maximum weight load limits may cause damage to the shelf or shelves, damage to the merchandiser, damage to store products, and potentially create a hazardous condition for customers and staff. Exceeding the indicated maximum weight load limits constitutes misuse as described in the Hussmann® Limited Warranty.

CIRCUIT #1	LOADING
120V	
115	

REV	ECN	DATE	REVISION DESCRIPTION	REV BY	CHKD BY	APPR BY
A	ECN-CAP-0004590	2016/04/4	RELEASED TO PRODUCTION	CB	CB	CB
B	ECN-CAP-0006979	2017/01/13	REVISED REAR STORAGE COIL	CB	CB	CB
C	ECN-CAP-0006207	2017/01/25	REVISED REAR STORAGE T-STAT	CB	CB	CB
D	ECN-COD-0016253	2022/02/28	NEW LIGHTS	AL	CB	CB
E	ECN-COD-0016140	2023/06/28	CHANGED FANS AND LIGHTS	CB	CB	CB

LOWER FRONT SECTION
LIGHT CIRCUIT= 11A 124W

TOP SECTION
4 LED LIGHT - NUA

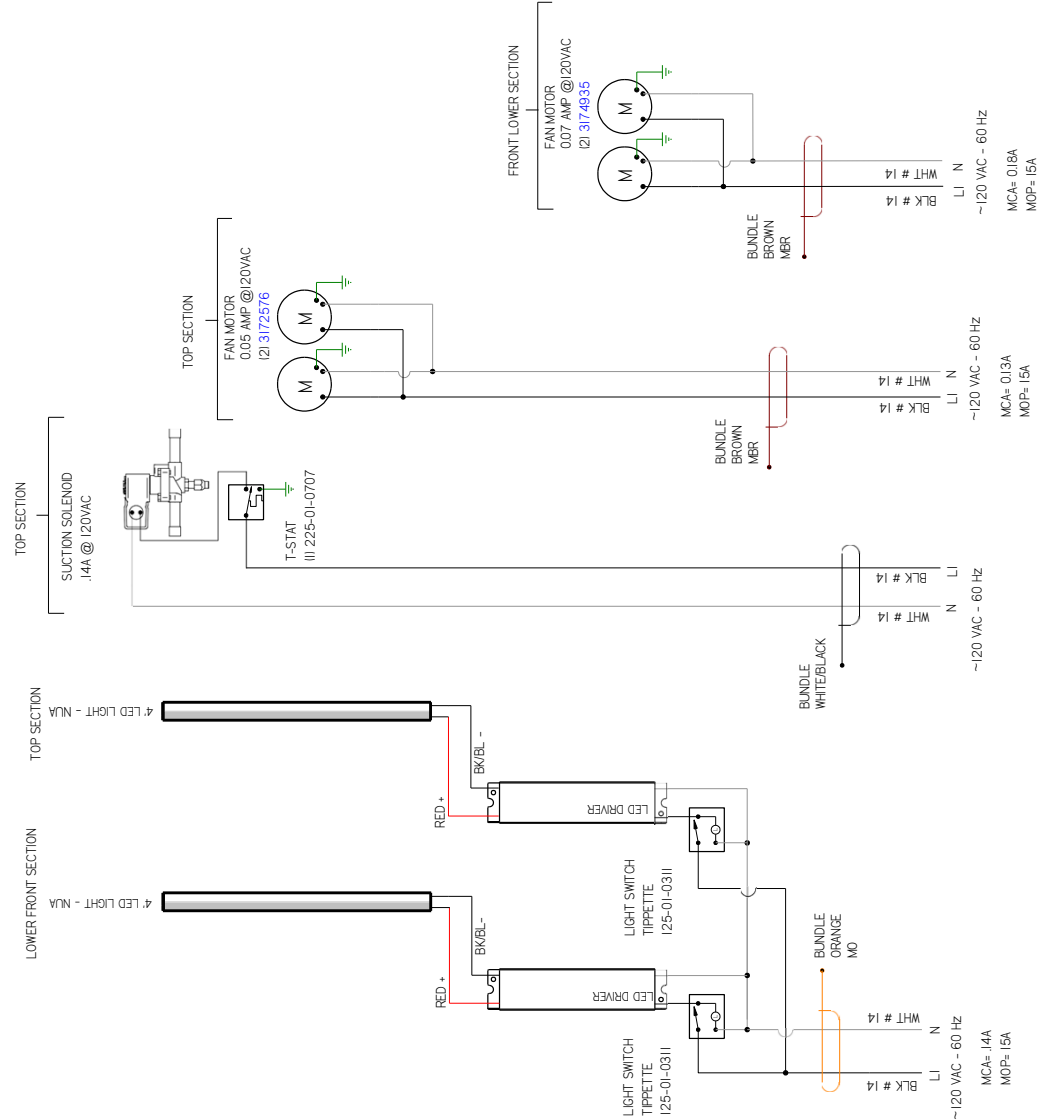

HTR ELMT 55"
100W 0.99A @ 120V
IH38820550

HUSSMANN
DIAGRAM=R3/CR3-
4- R DELI/BAKERY

MATERIAL - NUA
DATE DRAWN - 10-4-16
DRAWN BY - CRAIG BOOREY
REVIEWED BY - CRAIG BOOREY
UNLESS OTHERWISE SPECIFIED DIMENSIONS ARE IN INCHES.
TOLERANCES ARE:
DECIMALS .XX +0.3 .XXX
ANGLES ± 2°

ECN-CAP-0004590
REF -
SHEET 1 OF 2
THIRD PROJECTION

3016443 | E

NOTES:
CASE MUST BE GROUNDED
WHEN PASSING WIRES THROUGH METAL HOLES A GROMMET MUST BE USED

REVISION HISTORY				
REV	ECN	DATE	REV BY	APP BY
A	ECN-CAP-0004590	2016/04/4	CB	CB
B	ECN-CAP-00045979	2017/01/13	CB	CB
C	ECN-CAP-0006207	2017/01/25	CB	CB
D	ECN-COD-0019253	2022/02/08	AL	CB
E	ECN-COD-0019140	2023/08/28	CB	CB

REVISION DESCRIPTION				
A	RELEASED TO PRODUCTION			
B	REVISED REAR STORAGE COIL			
C	REVISED REAR STORAGE T-STAT			
D	NEW LIGHTS			
E	CHANGED FANS AND LIGHTS			

LOWER FRONT SECTION
"OPTIONAL B"

SUCTION SOLENOID
14A @ 120VAC

T-STAT
III 225-01-0707

REAR STORAGE COOLER UNIT
RT-12 0.30 @ 115V

DIGITAL T-STAT
SENSOR

SUCTION SOLENOID
14A @ 120VAC

OPTIONAL REAR STORAGE

TOP SECTION
SHELF LIGHT
"OPTIONAL D"

LED LIGHT -N/A

LED DRIVER

LED LIGHT -N/A

LOWER FRONT SECTION
"OPTIONAL A"

LIGHT CIRCUIT= 06A 6.2W

TOP SECTION
SHELF LIGHT
"OPTIONAL D"

LED LIGHT -N/A

LED DRIVER

LED LIGHT -N/A

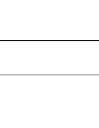
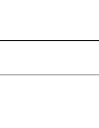
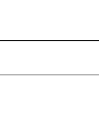
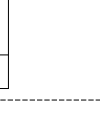
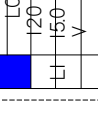
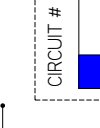
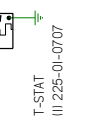
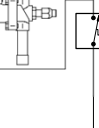
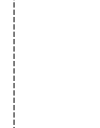
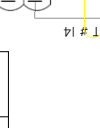
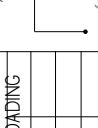
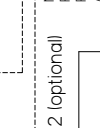
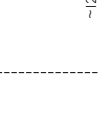
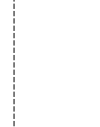
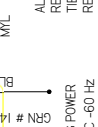
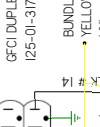
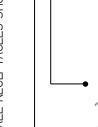
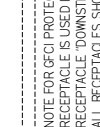
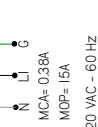
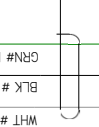
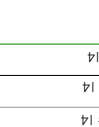
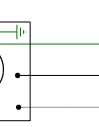
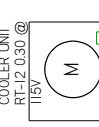
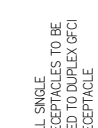
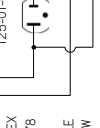
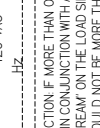
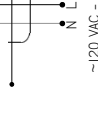
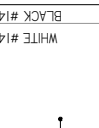
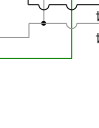
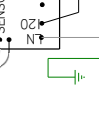
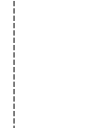
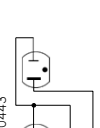
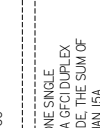
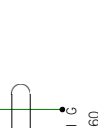
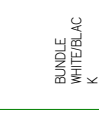
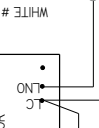
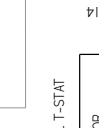
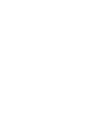
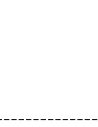
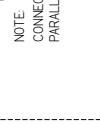
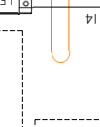
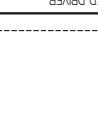
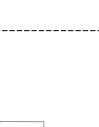
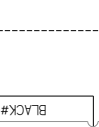
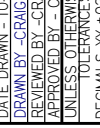
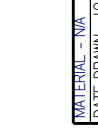
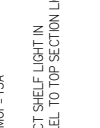
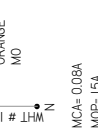
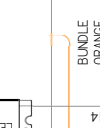
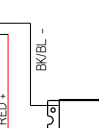
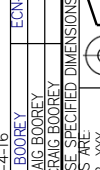
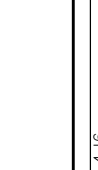
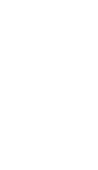

CIRCUIT #1	LOADING
120V	
117	

REVISION HISTORY						
REV	ECN	DATE	DESCRIPTION	REV BY	CHKD BY	APPR BY
A	ECN-CAP-0004590	2016/01/04	RELEASED TO PRODUCTION	CS	CS	CS
B	ECN-CAP-0003979	2017/01/15	REVISED REAR STORAGE COIL	CS	CS	CS
C	ECN-CAP-0006207	2017/01/25	REVISED REAR STORAGE T-STAT	CS	CS	CS
D	ECN-COD-2011253	2012/02/08	NEW LIGHTS	AL	CS	CS
E	ECN-COD-2018140	2012/08/28	CHANGED FANS AND LIGHTS	CS	CS	CS

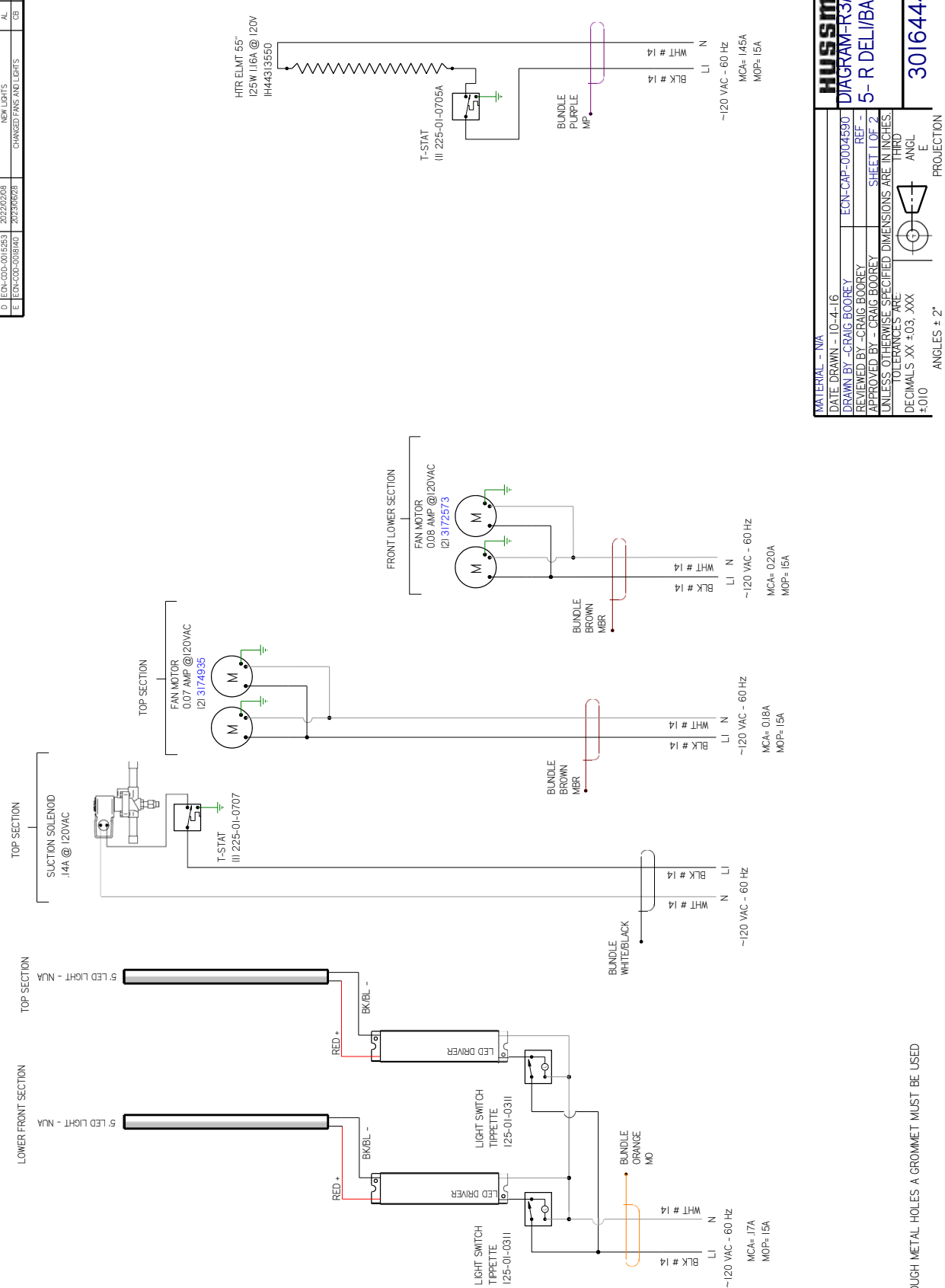

MATERIAL - N/A

DATE DRAWN - 10-4-16
 DRAWN BY - CRAIG BOOREY
 REVIEWED BY - CRAIG BOOREY
 APPROVED BY - CRAIG BOOREY

ECN-CAP-0004590
 REF -
 SHEET 1 OF 2

UNLESS OTHERWISE SPECIFIED DIMENSIONS ARE IN INCHES.
 TOLERANCES ARE:
 FRACTIONS .XX
 DECIMALS .XX +03 .XXX
 ANGLES ± 2°

HUSSMANN
DIAGRAM-R3/CR3-
5- R DELI/BAKERY

3016444 | E

NOTES:
 CASE MUST BE GROUNDED
 WHEN PASSING WIRES THROUGH METAL HOLES A GROMMET MUST BE USED

CIRCUIT #1
LOADING

120V	
21	

LOWER FRONT SECTION

3 LED LIGHT - NUA

3 LED LIGHT - NUA

TOP SECTION

3 LED LIGHT - NUA

SUCTION SOLENOID
J4A @ 120VAC

T-STAT
III 225-0-10707

TOP SECTION

FAN MOTOR
0.05 AMP @ 120VAC
(3) 3172576

M

M

M

FRONT LOWER SECTION

FAN MOTOR
0.07 AMP @ 120VAC
(3) 3174935

M

M

M

HTR ELMT 67"
150W 139A @ 120V
IH38821550

T-STAT
III 225-0-10705A

BUNDLE
PURPLE
MP

WHT # 14
LI N
BLK # 14
~120 VAC - 60 Hz
MCA= 174A
MOP= 15A

WHT # 14
LI N
BLK # 14
~120 VAC - 60 Hz
MCA= 019A
MOP= 15A

WHT # 14
LI N
BLK # 14
~120 VAC - 60 Hz
MCA= 026A
MOP= 15A

WHT # 14
LI N
BLK # 14
~120 VAC - 60 Hz
MCA= 026A
MOP= 15A

WHT # 14
LI N
BLK # 14
~120 VAC - 60 Hz
MCA= 174A
MOP= 15A

WHT # 14
LI N
BLK # 14
~120 VAC - 60 Hz
MCA= 174A
MOP= 15A

REV	EN	DATE	REVISION DESCRIPTION	REV BY	CHKD BY	APPR BY
B	EN-CAP-0005979	2017/01/13	REVISED REAR STORAGE COIL	CS	CS	CS
C	EN-CAP-0006207	2017/01/25	REVISED REAR STORAGE T-STAT	CS	CS	CS
D	EN-CAP-0013273	2018/07/17	REVISED LIGHT OPTIONS	CS	CS	CS
E	EN-COD-0018263	2022/02/28	NEW LIGHTS	AL	CS	CS
F	EN-CAP-0018140	2023/06/29	CHANGED FANS AND LIGHTS	CS	CS	CS

HUSSMANN
DIAGRAM=R3/CR3-
6- R DELI/BAKERY

MATERIAL - N/A
DATE DRAWN - 10-4-16
DRAWN BY - CRAIG BOOREY
REVIEWED BY - CRAIG BOOREY
APPROVED BY - CRAIG BOOREY
UNLESS OTHERWISE SPECIFIED DIMENSIONS ARE IN INCHES.
TOLERANCES ARE:
DIMENSIONS .XX +.03, .XXX
+0.0 ANGLE
E PROJECTION
ANGLES ± 2°

ECN-CAP-00024590 REF -
SHEET 1 OF 2
THIRD

3016445 | F

NOTES:
CASE MUST BE GROUNDED
WHEN PASSING WIRES THROUGH METAL HOLES A GROMMET MUST BE USED

REV	EN	DATE	REVISION DESCRIPTION	REV BY	CHKD BY	APPR BY
B	EN-CAP-0005979	2017/01/13	REVISED REAR STORAGE COIL	CB	CB	CB
C	EN-CAP-0006207	2017/01/25	REVISED REAR STORAGE T-STAT	CB	CB	CB
D	EN-CAP-0013273	2018/07/17	REVISED LIGHT OPTIONS	CB	CB	CB
E	EN-C03-0018263	2022/02/28	NEW LIGHTS	AL	CB	CB
F	EN-CAP-0018140	2023/06/29	CHANGED FANS AND LIGHTS	CB	CB	CB

TOP SECTION SHELF LIGHT 'OPTION D'

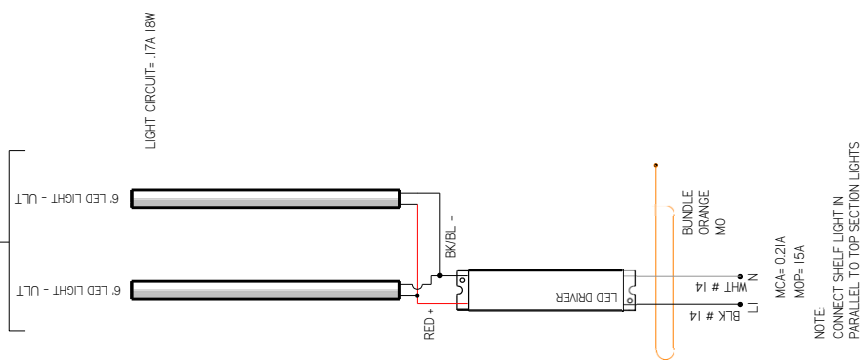

OPTIONAL REAR STORAGE

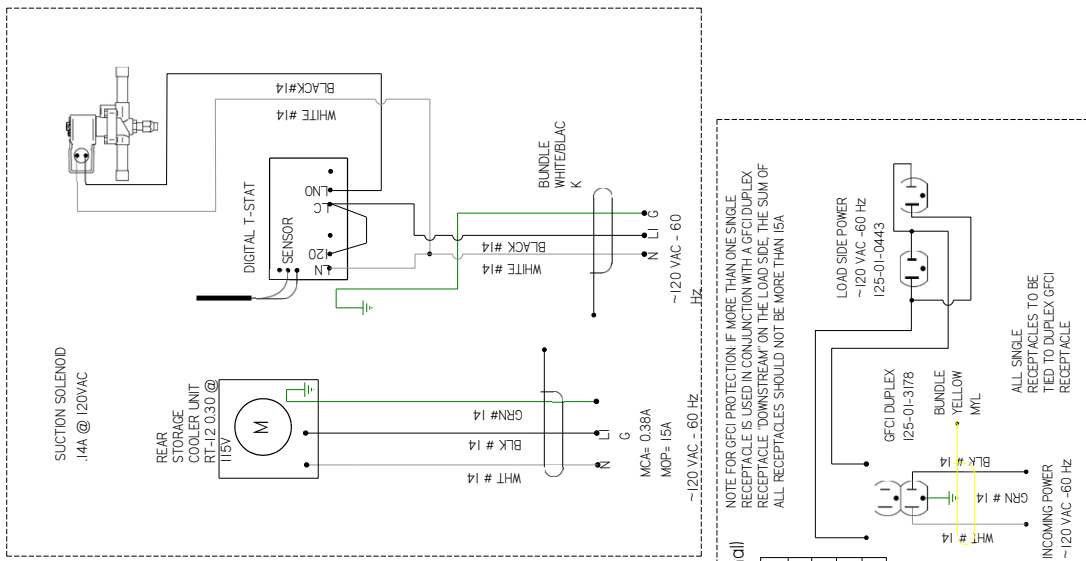

LOWER FRONT SECTION 'OPTION B'

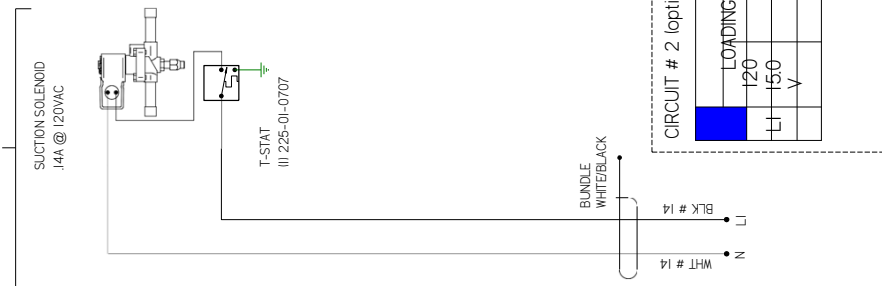

LOWER FRONT SECTION 'OPTION A'

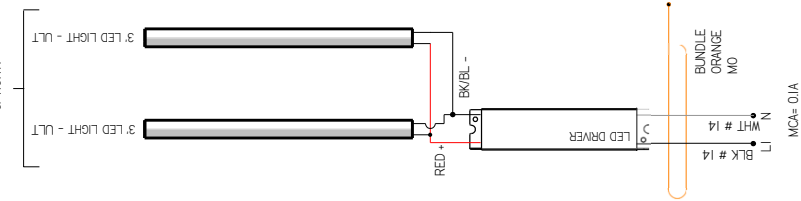

HUSSMANN
DIAGRAM=R3/CR3-
6- R DELI/BAKERY

MATERIAL - N/A
 DATE DRAWN - 10-4-16
 DRAWN BY - CRAIG BOOREY
 REVIEWED BY - CRAIG BOOREY
 APPROVED BY - CRAIG BOOREY
 UNLESS OTHERWISE SPECIFIED DIMENSIONS ARE IN INCHES.
 TO TOLERANCES SHOWN
 DECIMALS .XX +0.3 .XXX
 ANGLES ± 2°

ECN-CAP-0004590 REF -
 SHEET 2 OF 2
 DIMENSIONS ARE IN INCHES.
 TO TOLERANCES SHOWN
 DECIMALS .XX +0.3 .XXX
 ANGLES ± 2°

3016445 | F

NOTES:
 CASE MUST BE GROUNDED
 WHEN PASSING WIRES THROUGH METAL HOLES A GROMMET MUST BE USED

CIRCUIT #1	LOADING
120V	
1-1	2-7

REV	ECN	DATE	REVISION HISTORY	REV BY	CHKD BY	APPR BY
A	ECN-CAP-0004590	2016/04/04	RELEASED TO PRODUCTION	CB	CB	CB
B	ECN-CAP-0005979	2017/01/13	REVISED REAR STORAGE COIL	CB	CB	CB
C	ECN-CAP-0006207	2017/01/25	REVISED REAR STORAGE T-STAT	CB	CB	CB
D	ECN-COD-0019253	2022/02/08	NEW LIGHTS	AL	CB	CB
E	ECN-COD-0018140	2023/09/29	CHANGED FANS AND LIGHTS	CB	CB	CB

LOWER FRONT SECTION
4 LED LIGHT - NUA

TOP SECTION
4 LED LIGHT - NUA

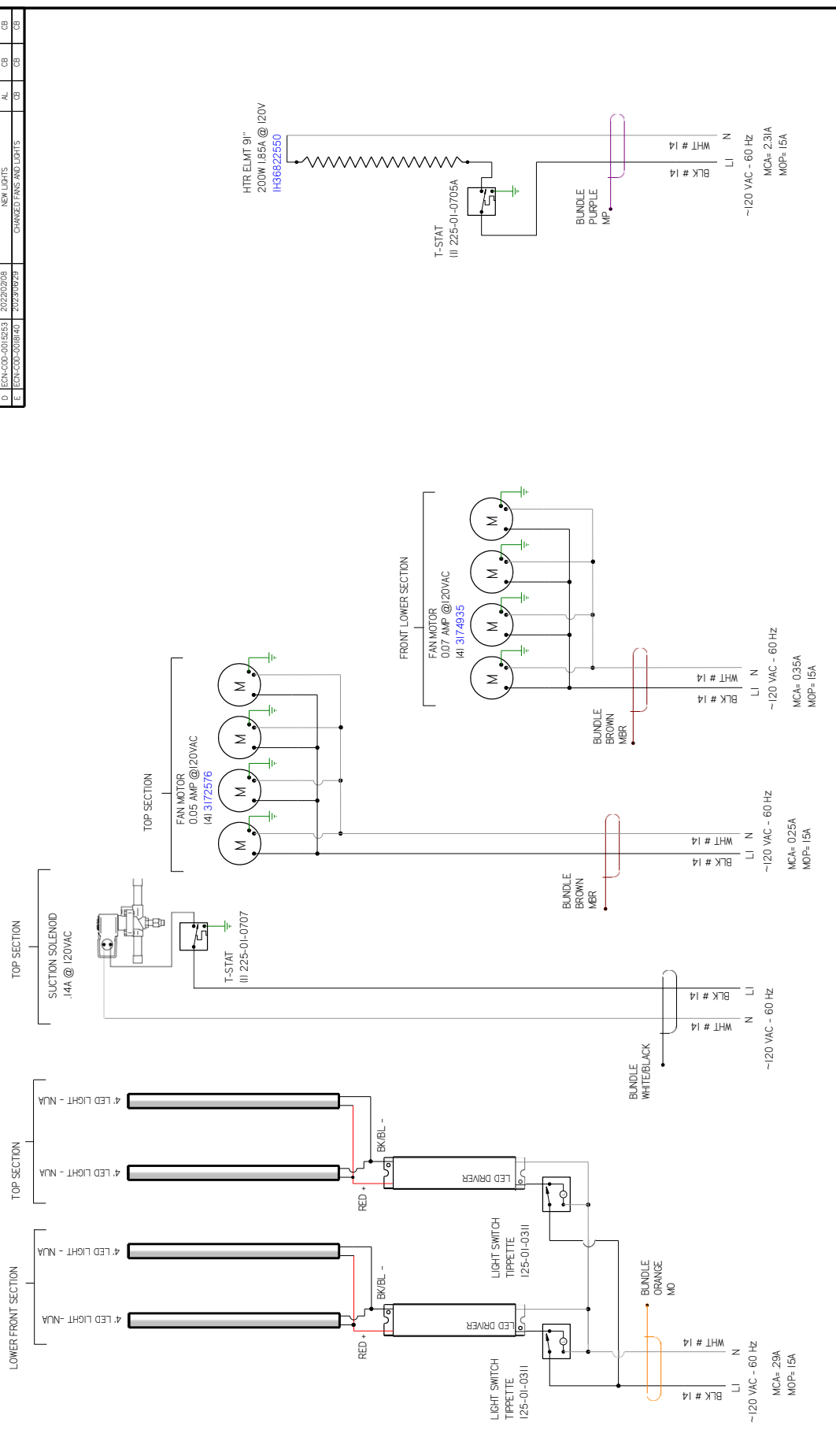

HUSSMANN
DIAGRAM=R3/CR3-
8- R DELI/BAKERY

MATERIAL - NUA
DATE DRAWN - 10-4-16
DRAWN BY - CRAIG BOOREY
REVIEWED BY - CRAIG BOOREY
APPROVED BY - CRAIG BOOREY
UNLESS OTHERWISE SPECIFIED DIMENSIONS ARE IN INCHES.
TOLERANCES ARE:
FRACTIONS - AS SHOWN
DECIMALS .XX +03 .XXX
ANGLES ± 2°

ECN-CAP-0004590
REF -
SHEET 1 OF 2
THIRD PROJECTION

3016446 | E

NOTES:
CASE MUST BE GROUNDED
WHEN PASSING WIRES THROUGH METAL HOLES A GROMMET MUST BE USED

REV	EN	DATE	REVISION DESCRIPTION	REV BY	CHKD BY	APPR BY
A	ECN-CAP-0004590	2016/04/04	RELEASED TO PRODUCTION	CB	CB	CB
B	ECN-CAP-0005979	2017/01/13	REVISED REAR STORAGE COIL	CB	CB	CB
C	ECN-CAP-0006207	2017/01/25	REVISED REAR STORAGE T-STAT	CB	CB	CB
D	ECN-COD-0015253	2022/02/08	NEW LIGHTS	AL	CB	CB
E	ECN-COD-0018140	2023/09/29	CHANGED PANS AND LIGHTS	CB	CB	CB

TOP SECTION
SHELF LIGHT
"OPTION D"

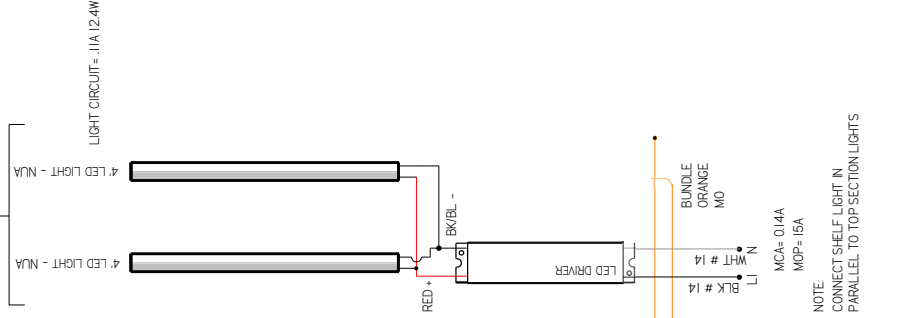

NOTE
CONNECT SHELF LIGHT IN
PARALLEL TO TOP SECTION LIGHTS

OPTIONAL REAR STORAGE

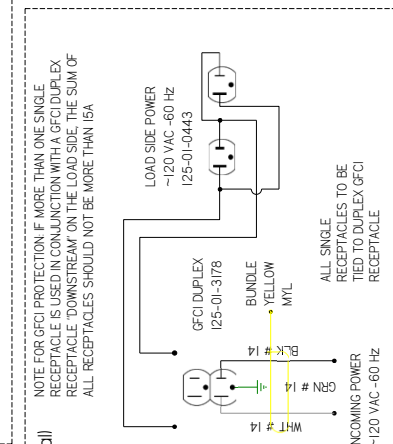
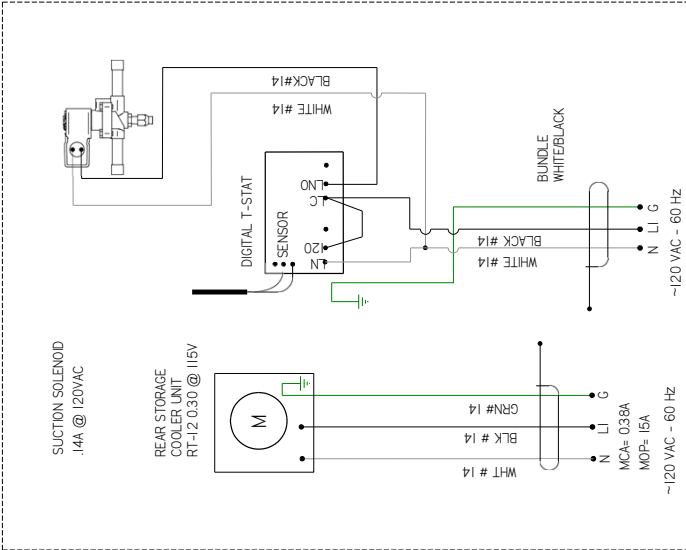

CIRCUIT # 2 (optional)

LOADING	120 V	150
LI		

NOTE FOR GFCI PROTECTION IF MORE THAN ONE SINGLE RECEPTACLE IS USED IN CONJUNCTION WITH A GFCI DUPLEX RECEPTACLE "DOWNSTREAM" ON THE LOAD SIDE, THE SUM OF ALL RECEPTACLES SHOULD NOT BE MORE THAN 15A

ALL SINGLE RECEPTACLES TO BE TIED TO DUPLEX GFCI RECEPTACLE

LOWER FRONT SECTION
"OPTION B"

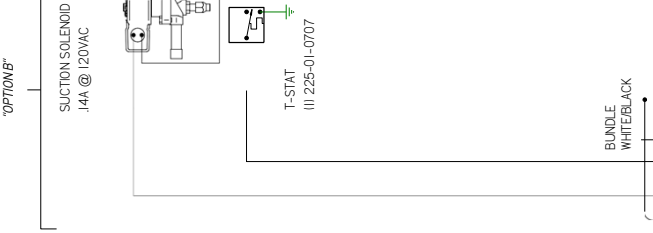

LOWER FRONT SECTION
"OPTION A"

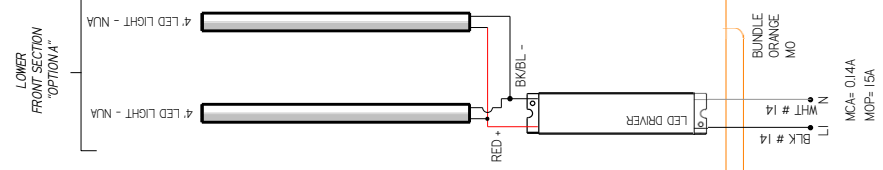

NOTE
CONNECT SHELF LIGHT IN
PARALLEL TO LOWER FRONT
SECTION LIGHTS

HUSSMANN
DIAGRAM-R3/CR3-
8- R DELI/BAKERY

MATERIAL - N/A
DATE DRAWN - 10-4-16
DRAWN BY - CRAIG BOOREY
REVIEWED BY - CRAIG BOOREY
APPROVED BY - CRAIG BOOREY
UNLESS OTHERWISE SPECIFIED DIMENSIONS ARE IN INCHES.
TOLERANCES ARE:
FRACTIONS .XXX
DECIMALS .XX +0.3, .XXX
ANGLES ± 2°

ECN-CAP-0004590 REF -
SHEET 2 OF 2
THIRD
ANGI
E
PROJECTION

3016446 | E

NOTES:
CASE MUST BE GROUNDED
WHEN PASSING WIRES THROUGH METAL HOLES A GROMMET MUST BE USED

CIRCUIT #1				
LOADING				
120V				
115				

REV	ECN	DATE	REVISION DESCRIPTION	REV BY	CHKD BY	APPR BY
A	ECN-CAP-0004590	2018/06/04	RELEASED TO PRODUCTION	CB	CB	CB
B	ECN-CAP-0005979	2017/01/03	REVISED REAR STORAGE COIL	CB	CB	CB
C	ECN-CAP-0006207	2017/01/25	REVISED REAR STORAGE T-STAT	CB	CB	CB
D	ECN-COD-0015253	2022/02/08	NEW LIGHTS	AL	CB	CB
E	ECN-COD-0018140	2023/06/29	CHANGED FANS AND LIGHTS	CB	CB	CB

LIGHT CIRCUIT= 27A 236W

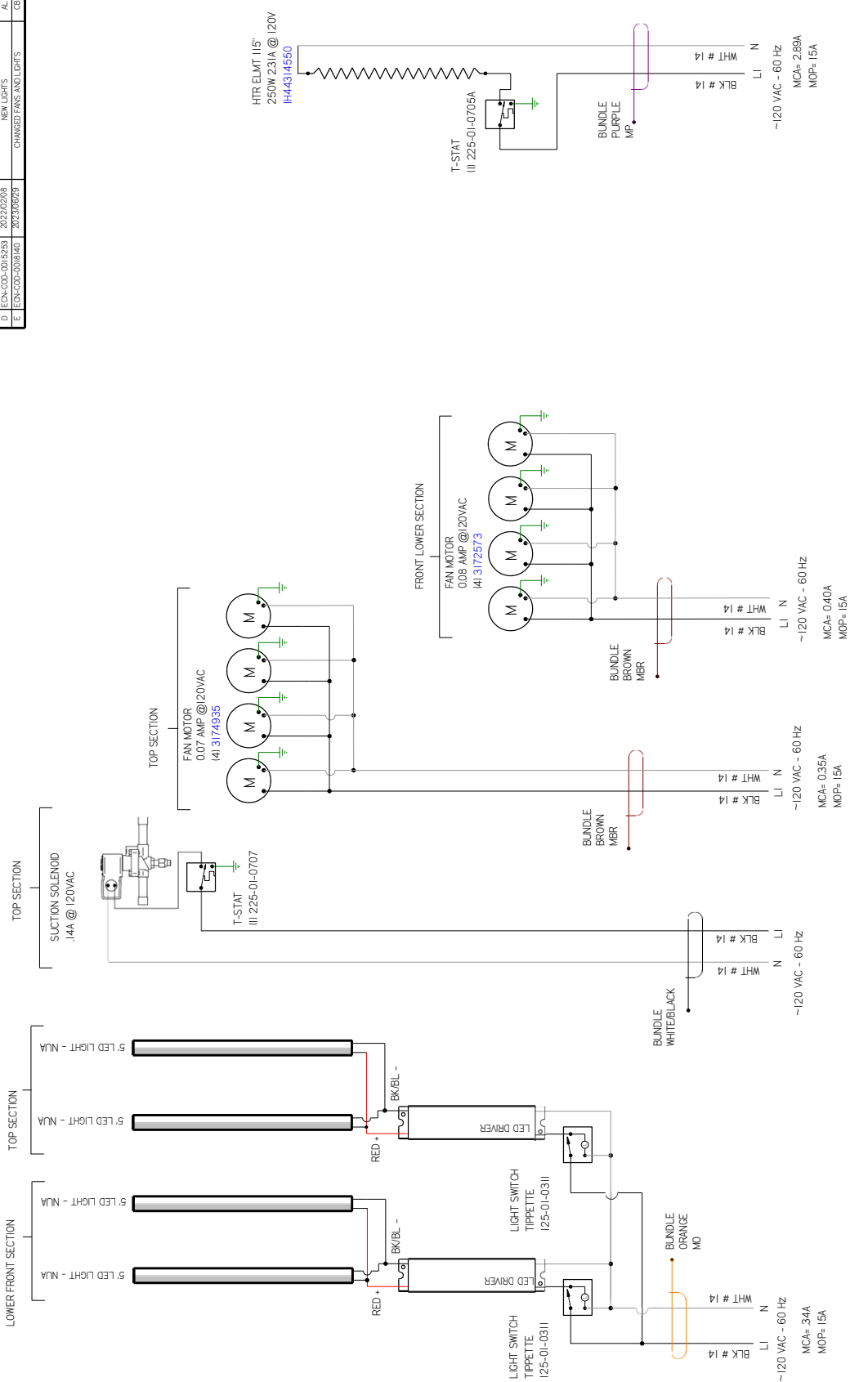

HUSSMANN
DIAGRAM=R3/CR3-10
-R DELI/BAKERY

MATERIAL - N/A
DATE DRAWN - 10-4-16
DRAWN BY - CRAIG BOOREY
REVIEWED BY - CRAIG BOOREY
APPROVED BY - CRAIG BOOREY
UNLESS OTHERWISE SPECIFIED DIMENSIONS ARE IN INCHES.
TOLERANCES ARE:
FRACTIONS
DECIMALS .XX +03 .XXX
ANGLES ± 2°

ECN-CAP-0004590
REF -
SHEET 1 OF 2
THIRD

PROJECTION
E
3016447

NOTES:
CASE MUST BE GROUNDED
WHEN PASSING WIRES THROUGH METAL HOLES A GROMMET MUST BE USED

REV	ECN	DATE	REVISION DESCRIPTION	REV BY	CHK BY	APPR BY
A	ECN-CAP-0004590	2018/01/04	RELEASED TO PRODUCTION	CB	CB	CB
B	ECN-CAP-0005979	2017/01/13	REVISED REAR STORAGE COIL	CB	CB	CB
C	ECN-CAP-0006207	2017/01/25	REVISED REAR STORAGE T-STAT	CB	CB	CB
D	ECN-COD-0015251	2022/02/08	NEW LIGHTS	AL	CB	CB
E	ECN-COD-0018140	2023/06/29	CHANGED FANS AND LIGHTS	CB	CB	CB

REVISION HISTORY



NOTE:
CONNECT SHELF LIGHT IN
PARALLEL TO LOWER FRONT
SECTION LIGHTS

OPTIONAL REAR STORAGE

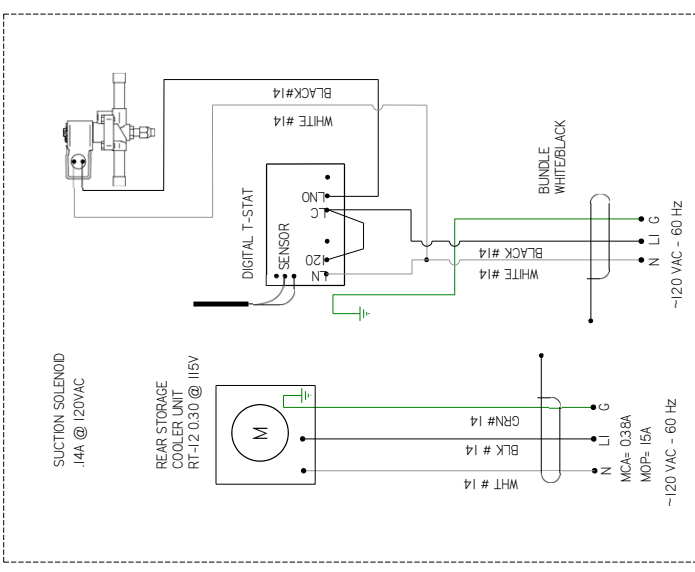

NOTE FOR GFCI PROTECTION IF MORE THAN ONE SINGLE RECEPTACLE IS USED IN CONJUNCTION WITH A GFCI DUPLEX RECEPTACLE, DOWNSTREAM ON THE LOAD SIDE, THE SUM OF ALL RECEPTACLES SHOULD NOT BE MORE THAN 15A

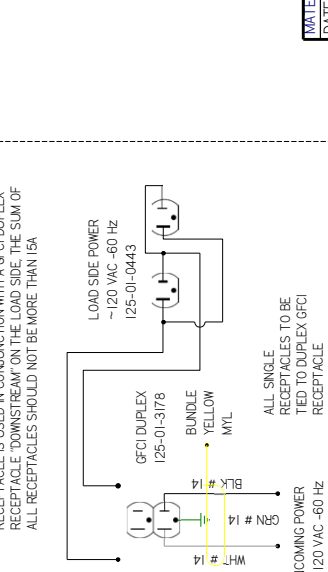

LOWER FRONT SECTION
"OPTION B"

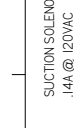

NOTE:
CONNECT SHELF LIGHT IN
PARALLEL TO LOWER FRONT
SECTION LIGHTS

LOWER
FRONT SECTION
"OPTION A"

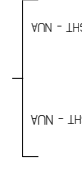

NOTE:
CONNECT SHELF LIGHT IN
PARALLEL TO LOWER FRONT
SECTION LIGHTS

NOTE:
CASE MUST BE GROUNDED
WHEN PASSING WIRES THROUGH METAL HOLES A GROMMET MUST BE USED

TOP SECTION
SHELF LIGHT
"OPTION D"



NOTE:
CONNECT SHELF LIGHT IN
PARALLEL TO TOP SECTION LIGHTS

HUSSMANN
DIAGRAM=R3/CR3-10
-R DELI/BAKERY

MATERIAL - N/A
DATE DRAWN - 10-4-16
DRAWN BY - CRAIG BOOREY
REVIEWED BY - CRAIG BOOREY
APPROVED BY - CRAIG BOOREY
UNLESS OTHERWISE SPECIFIED DIMENSIONS ARE IN INCHES.
TOLERANCES ARE:
FRACTIONS - AS SHOWN
DECIMALS .XX +0.3 .XXX
+0.0

ECN-CAP-0004590
REF -
SHEET 2 OF 2
THIRD
ANGU
E
PROJECTION

3016447 | E

NOTE:
CASE MUST BE GROUNDED
WHEN PASSING WIRES THROUGH METAL HOLES A GROMMET MUST BE USED

CIRCUIT #1			
LOADING	120V		
	115		
	110		

REV	ECN	DATE	REVISION DESCRIPTION	REV BY	CHKD BY	APPR BY
A	ECN-CAP-0004590	2016/01/04	RELEASED TO PRODUCTION	CB	CB	CB
B	ECN-CAP-0005979	2017/01/13	REVISED REAR STORAGE COIL	CB	CB	CB
C	ECN-CAP-0006207	2017/01/25	REVISED REAR STORAGE T-STAT	CB	CB	CB
D	ECN-COD-0015251	2022/02/08	NEW LIGHTS	AL	CB	CB
E	ECN-COD-0018140	2023/06/29	CHANGED FANS AND LIGHTS	CB	CB	CB

LIGHT CIRCUIT= 34A 372W

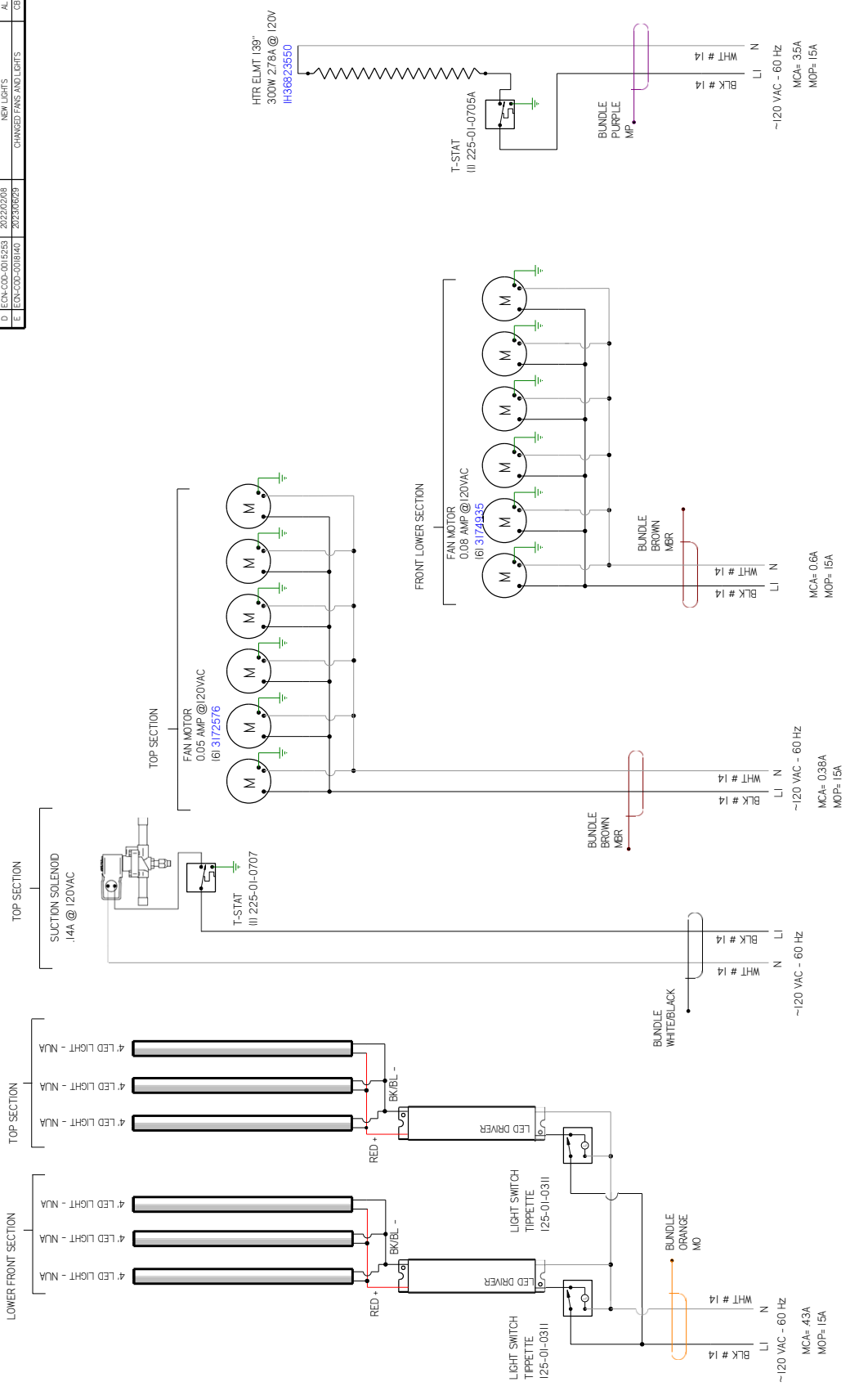

HUSSMANN
DIAGRAM=R3/CR3-12
-R DELI/BAKERY

MATERIAL - N/A
DATE DRAWN - 10-4-16
DRAWN BY - CRAIG BOOREY
REVIEWED BY - CRAIG BOOREY
APPROVED BY - CRAIG BOOREY
UNLESS OTHERWISE SPECIFIED DIMENSIONS ARE IN INCHES.
TOLERANCES ARE TO FRACTIONS PARTS
DECIMALS .XX +03 .XXX
+0.0 ANGL
E PROJECTION
ANGLES ± 2°

ECN-CAP-0004590 REF -
SHEET 1 OF 2
THIRD

3016451 | E

NOTES:
CASE MUST BE GROUNDED
WHEN PASSING WIRES THROUGH METAL HOLES A GROMMET MUST BE USED

REV	ECN	DATE	REVISION DESCRIPTION	REV BY	CHKD BY	APPR BY
A	ECN-CAP-0004590	2016/01/04	RELEASED TO PRODUCTION	CB	CB	CB
B	ECN-CAP-0005979	2017/01/13	REVISED REAR STORAGE COIL	CB	CB	CB
C	ECN-CAP-0006207	2017/01/25	REVISED REAR STORAGE T-STAT	CB	CB	CB
D	ECN-COD-0015251	2022/02/08	NEW LIGHTS	AL	CB	CB
E	ECN-COD-0018140	2023/06/29	CHANGED FANS AND LIGHTS	CB	CB	CB

TOP SECTION
SHELF LIGHT
"OPTION D"

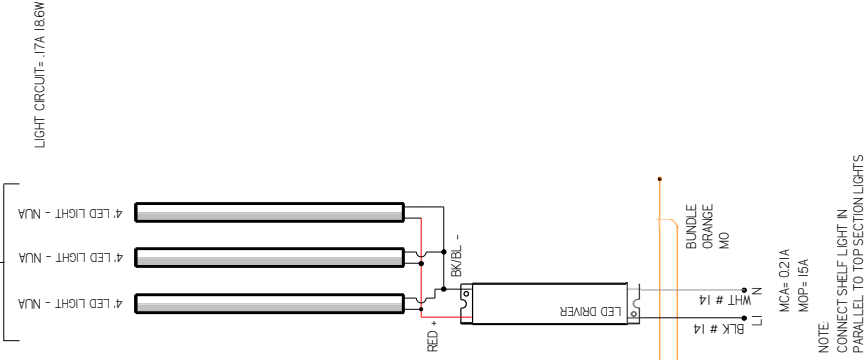

OPTIONAL REAR STORAGE

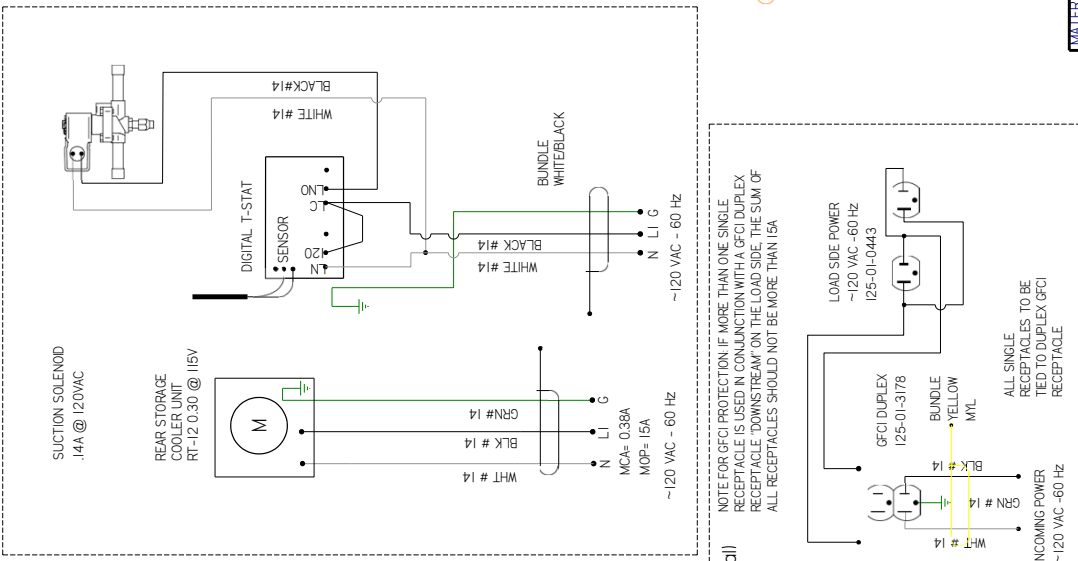

LOWER FRONT SECTION
"OPTION B"

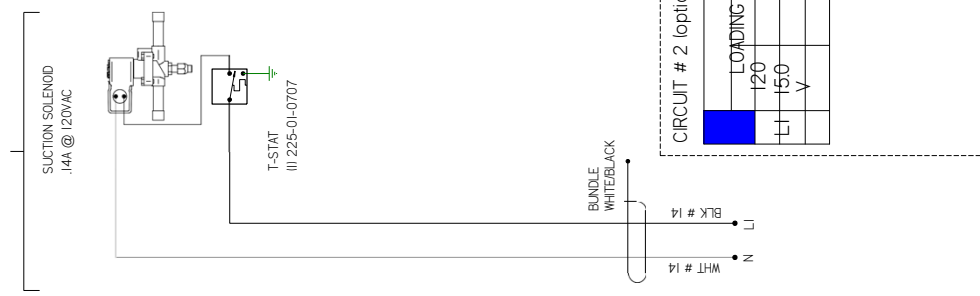

LOWER
FRONT SECTION
"OPTION A"

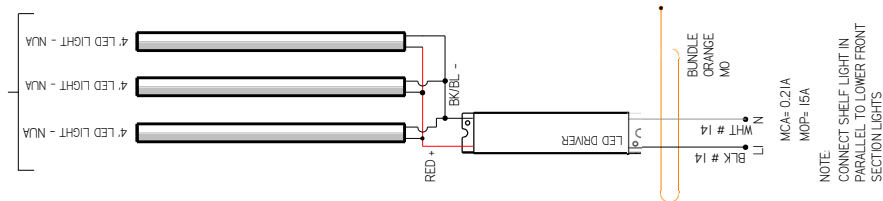

HUSSMANN
DIAGRAM=R3/CR3-1Z
-R DELI/BAKERY

MATERIAL - N/A

DATE DRAWN - 10-4-16

DRAWN BY - CRAIG BOOREY

REVIEWED BY - CRAIG BOOREY

APPROVED BY - CRAIG BOOREY

UNLESS OTHERWISE SPECIFIED DIMENSIONS ARE IN INCHES.
TOLERANCES ARE:
DIMENSIONS .XX +.03 .XXX
+0.0

ECN-CAP-0004590 REF -

SHEET 2 OF 2

TO LEARNES PART

ANGLES ± 2°

PROJECTION

3016451 | E

NOTES:
CASE MUST BE GROUNDED
WHEN PASSING WIRES THROUGH METAL HOLES A GROMMET MUST BE USED

CIRCUIT #1
LOADING

120V	
115V	
110V	
105V	

LIGHT CIRCUIT = .06A 62W

LOWER FRONT
SECTION

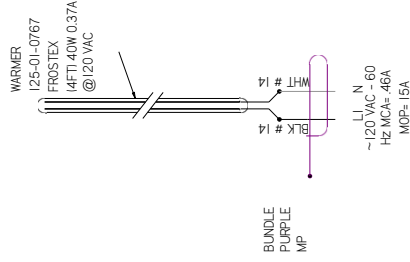
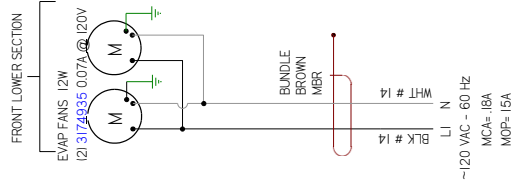
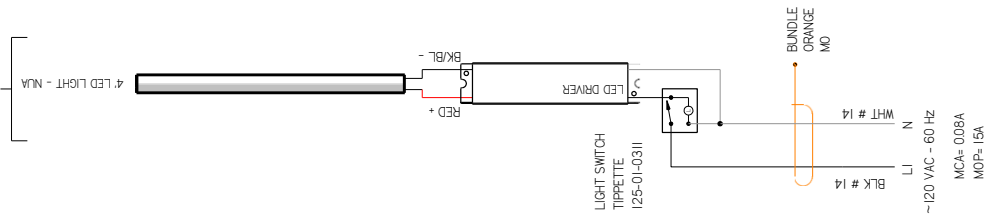

REV	EN	DATE	REVISION DESCRIPTION	REV BY	CHKD BY	APPR BY
D	ECN-CAP-0013865	2018/07/26	CHANGED HEATER TO FOIL TAPE	CB	CB	CB
E	ECN-CAP-0014508	2018/09/13	CHANGED HEATER TO FRUSTEX	CB	CB	CB
F	ECN-COD-0015253	2022/02/09	NEW LIGHTS	AL	CB	CB
G	ECN-COD-0015623	2022/02/07	NEW FANS FN	AL	CB	CB
H	ECN-COD-0018145	2023/07/24	CHANGED EVAP FAN	CB	CB	CB

MATERIAL - N/A

DATE DRAWN - 1-26-17

DRAWN BY - CRAIG BOOREY

ECN-CAP-0005712

REF -

SHEET 1 OF 2

UNLESS OTHERWISE SPECIFIED DIMENSIONS ARE IN INCHES.

TOLERANCES ARE:

DECIMALS .XX +03, .XXX

ANGLES ± 2°

HUSSMANN

DIAGRAM-R3/CR3-

P- 4R

3024010

H

PROJECTION

ANGL

E

±0.0

±0.0

REV	EN	DATE	REVISION DESCRIPTION	REV BY	CHKD BY	APPR BY
D	ECN-CAP-0003865	2018/07/26	CHANGED HEATER TO FOL TAPE	CB	CB	CB
E	ECN-CAP-0004508	2018/09/13	CHANGED HEATER TO FRIGILEX	CB	CB	CB
F	ECN-COD-0005253	2022/02/09	NEW LIGHTS	AL	CB	CB
G	ECN-COD-0005823	2023/07/07	NEW FANS FN	AL	CB	CB
H	ECN-COD-0008145	2023/07/24	CHANGED BWP FAN	CB	CB	CB

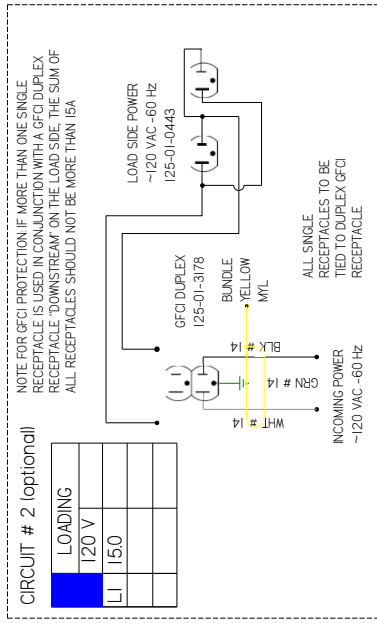
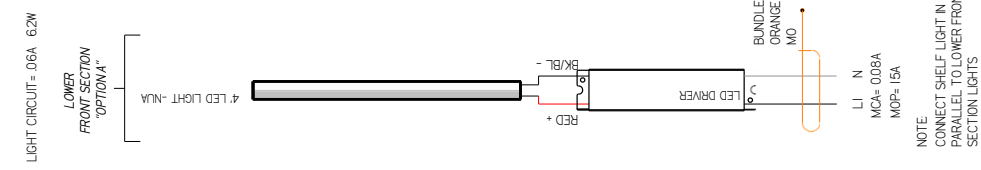
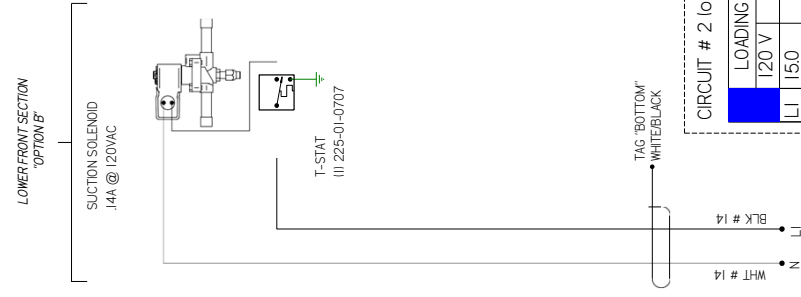
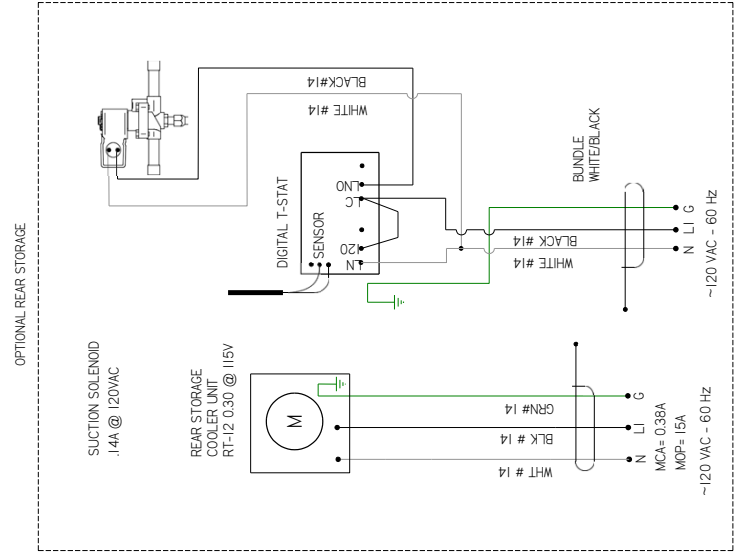

NOTE:
CONNECT SHELF LIGHT IN PARALLEL TO LOWER FRONT SECTION LIGHTS

HUSSMANN
DIAGRAM=R3/CR3-
P- 4R

MATERIAL - N/A

DATE DRAWN - 1-26-17

DRAWN BY - CRAIG BOOREY

REVIEWED BY - CRAIG BOOREY

APPROVED BY - CRAIG BOOREY

UNLESS OTHERWISE SPECIFIED DIMENSIONS ARE IN INCHES. THIRD ANGLE PROJECTION

DECIMALS .XX +03 .XXX

ANGLES ± 2°

CON-CAP-0005712 REF -

SHEET 2 OF 2

3024010 | H

NOTES:
CASE MUST BE GROUNDED WHEN PASSING WIRES THROUGH METAL HOLES A GROMMET MUST BE USED

CIRCUIT #1
LOADING

120V			
110			

LOWER FRONT SECTION

LIGHT CIRCUIT - 07A 7.4W

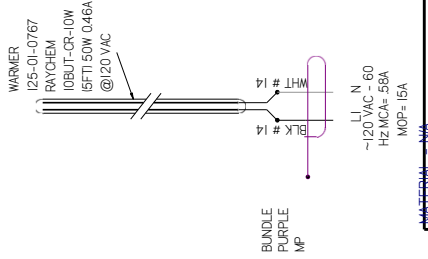
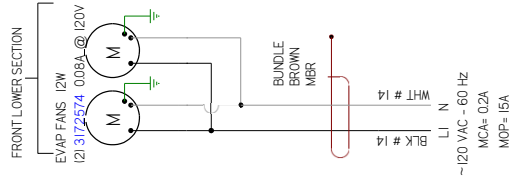
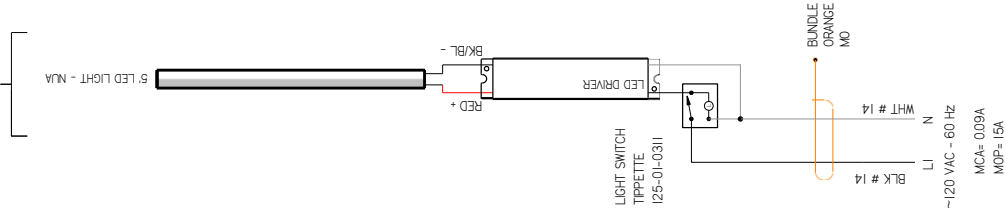

NOTES:
CASE MUST BE GROUNDED
WHEN PASSING WIRES THROUGH METAL HOLES A GROMMET MUST BE USED

REV	ECN	DATE	REVISION DESCRIPTION	REV BY	CHKD BY	APPR BY
B	ECN-CAP-00063919	2017/03/08	CHANGED 1 STAR WIRING	CB	CB	CB
C	ECN-CAP-00072822	2017/03/24	CHANGED HEATER	CB	CB	CB
D	ECN-COD-00156253	2022/02/09	NEW LIGHTS	AL	CB	CB
E	ECN-COD-00156253	2023/02/07	NEW FANS FN	AL	CB	CB
F	ECN-COD-00181451	2023/07/24	CHANGED EVAP DWS	CB	CB	CB
G	ECN-COD-00181715	2023/10/04	NEW FAN MOTOR	CB	CB	CB

HUSSMANN
DIAGRAM=R3/CR3-
P- 5R

DATE DRAWN - 1-26-17
DRAWN BY - CRAIG BOOREY
REVIEWED BY - CRAIG BOOREY
APPROVED BY - CRAIG BOOREY
UNLESS OTHERWISE SPECIFIED DIMENSIONS ARE IN INCHES.
TOLERANCES ARE:
DECIMALS .XX +0.3 .XXX
ANGLES ± 2°

PROJECTION

3024011 | G

REV	ECN	DATE	REVISION DESCRIPTION	REV BY	CHKD BY	APPR BY
B	ECN-CAP-0006319	2017/03/08	CHANGED T-STAT WIRING	CB	CB	CB
C	ECN-CAP-0007282	2017/03/24	CHANGED HEATER	CB	CB	CB
D	ECN-COD-0015623	2022/02/09	NEW LIGHTS	AL	CB	CB
E	ECN-COD-0015623	2023/02/07	NEW FANS FPN	AL	CB	CB
F	ECN-COD-0018145	2023/07/24	CHANGED EXHP DUNS	CB	CB	CB
G	ECN-COD-0018715	2023/07/24	NEW FAN MOTOR	CB	CB	CB

OPTIONAL REAR STORAGE

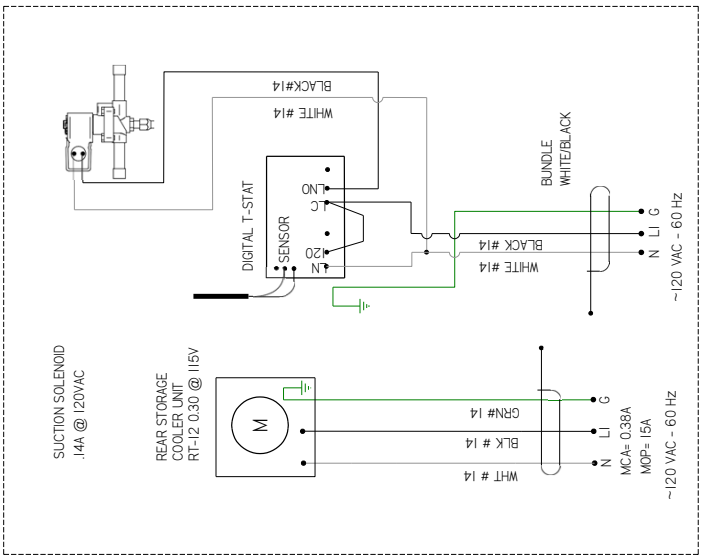

LOWER FRONT SECTION
"OPTION B"

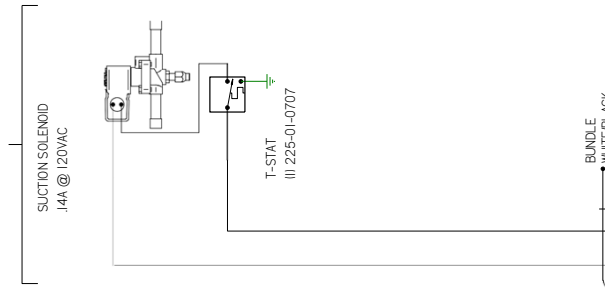

LIGHT CIRCUIT- 07A 7.4W

LOWER FRONT SECTION
"OPTION A"

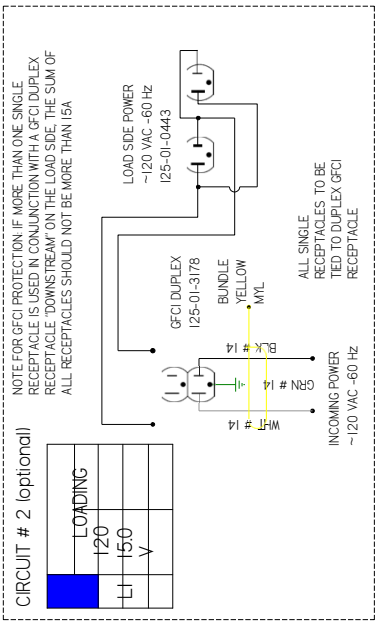
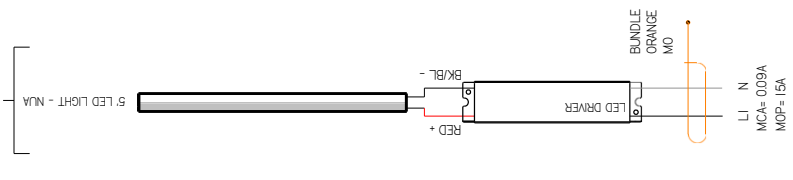

HUSSMANN
DIAGRAM=R3/CR3-
P- 5R

MATERIAL - N/A

DATE DRAWN - 1-26-17
DRAWN BY - CRAIG BOOREY
REVIEWED BY - CRAIG BOOREY

ECN-CAP-0005712
REF -
SHEET 2 OF 2

UNLESS OTHERWISE SPECIFIED DIMENSIONS ARE IN INCHES.
TOLERANCES ARE:
FRACTIONS .XX
DECIMALS .XX +03 .XX
ANGLES ± 2°

3024011 | G

NOTES:
CASE MUST BE GROUNDED
WHEN PASSING WIRES THROUGH METAL HOLES A GROMMET MUST BE USED

CIRCUIT #1			
LOADING	120V	15A	

LIGHT CIRCUIT - 08A 9W

LOWER FRONT SECTION

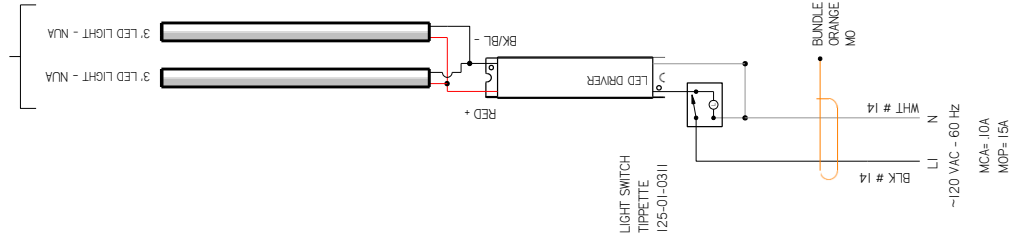

TOP SECTION

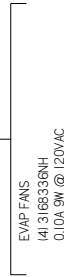

FRONT LOWER SECTION

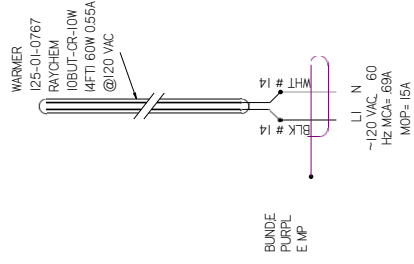
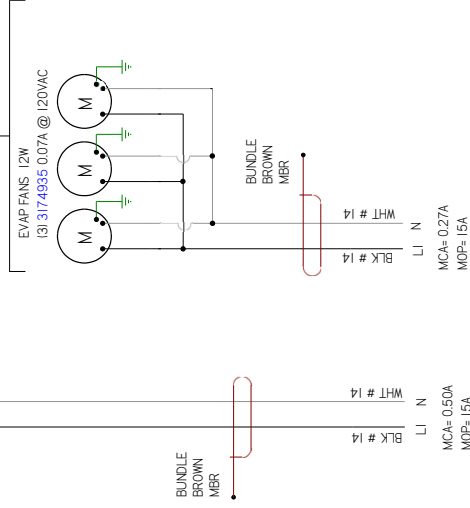

MATERIAL - N/A

DATE DRAWN - 1-26-17

DRAWN BY - CRAIG BOOREY

REVIEWED BY - CRAIG BOOREY

APPROVED BY - CRAIG BOOREY

UNLESS OTHERWISE SPECIFIED DIMENSIONS ARE IN INCHES.

TO LEADERS START HERE

DECIMALS .XX +03 .XXX

ANGLES ± 2°

HUSSMANN

DIAGRAM=R3/CR3-

P- 6R

3024013

G

PROJECTION

ANGL

E

ANGLES ± 2°

REVISION HISTORY			
REV	ECN	DATE	DESCRIPTION
C	ECN-CAP-0007282	2017/03/24	CHANGED HEATER
D	ECN-CAP-0018863	2018/08/10	ADDED LIGHT OVER PREP TOP
E	ECN-COD-2015253	2022/02/09	NEW LIGHTS
F	ECN-COD-2018623	2023/02/07	NEW FANS PM
G	ECN-COD-2018145	2023/07/24	CHANGED DWP FANS

OPTIONAL REAR STORAGE

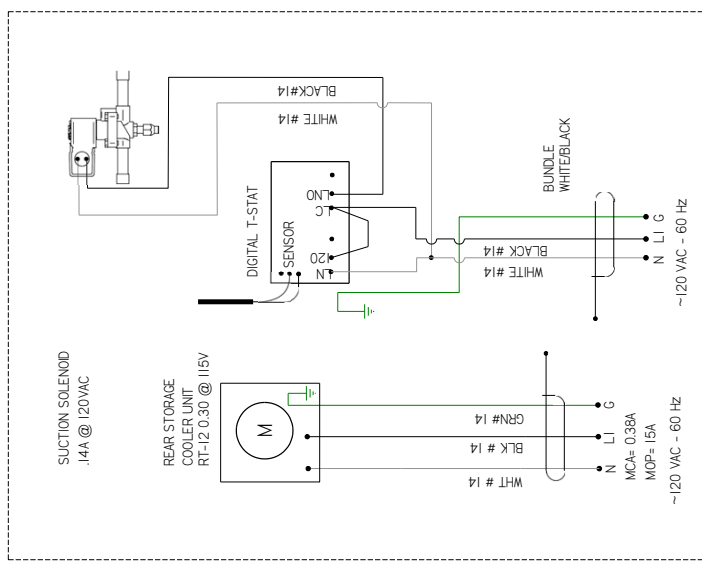

LOWER FRONT SECTION "OPTION B"

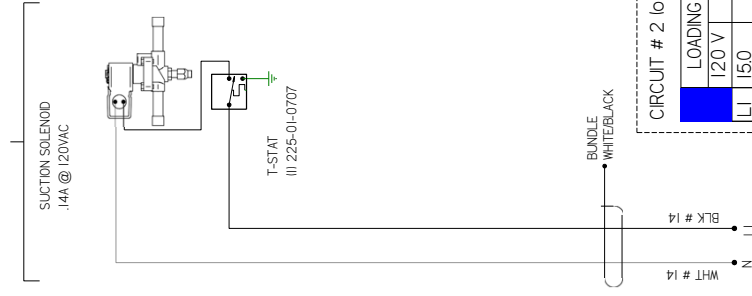

LOWER FRONT SECTION "OPTION A"

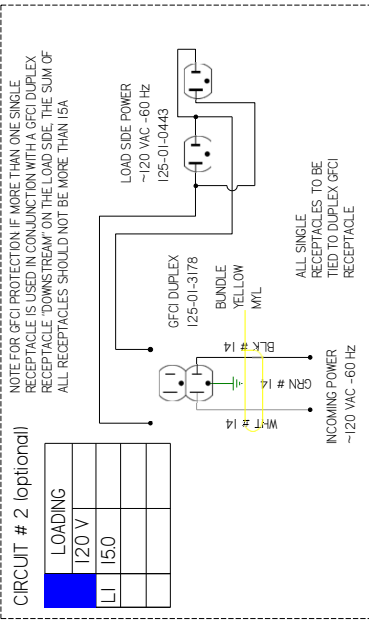
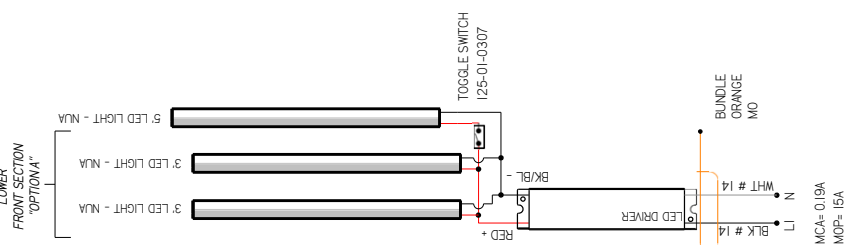

HUSSMANN
DIAGRAM=R3/CR3-
P- 6R

MATERIAL - N/A
 DATE DRAWN - 1-26-17
 DRAWN BY - CRAIG BOOREY
 REVIEWED BY - CRAIG BOOREY
 APPROVED BY - CRAIG BOOREY
 UNLESS OTHERWISE SPECIFIED DIMENSIONS ARE IN INCHES.
 TOLERANCES ARE:
 FRACTIONS AS SHOWN
 DECIMALS .XX +0.3, .XXX
 ANGLES ± 2°

PROJECTION

3024013 | G

NOTES:
 CASE MUST BE GROUNDED
 WHEN PASSING WIRES THROUGH METAL HOLES A GROMMET MUST BE USED

REV	ECN	DATE	REVISION HISTORY	REV BY	CHKD BY	APPR BY
C	ECN-CAP-000282	2017/03/24	CHANGED HEATER	CB	CB	CB
D	ECN-CAP-0020443	2020/03/03	ADDED OPTIONAL SHOW CASE LIGHTS	CB	CB	CB
E	ECN-COD-0015253	2022/02/09	NEW LIGHTS	AL	CB	CB
F	ECN-COD-0015823	2023/02/07	NEW FANS PIN	AL	CB	CB
G	ECN-COD-0018145	2023/07/24	CHANGED EVAP FANS	CB	CB	CB

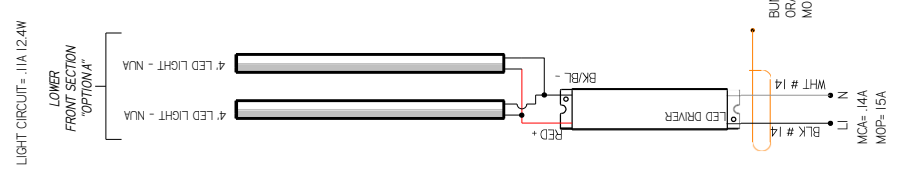
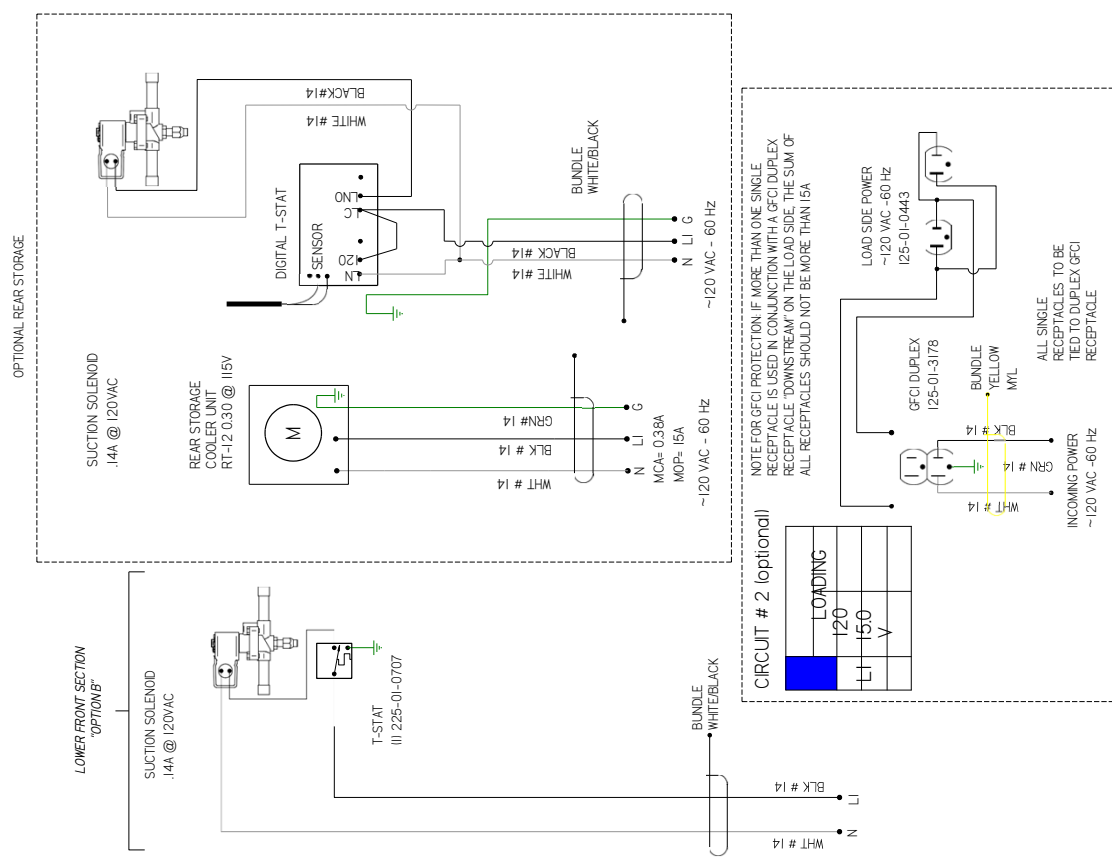

NOTES:
CASE MUST BE GROUNDED
WHEN PASSING WIRES THROUGH METAL HOLES A GROMMET MUST BE USED

MATERIAL - N/A
DATE DRAWN - 1-26-17
DRAWN BY - CRAIG BOOREY
REVIEWED BY - CRAIG BOOREY
APPROVED BY - CRAIG BOOREY
UNLESS OTHERWISE SPECIFIED DIMENSIONS ARE IN INCHES.
TOLERANCES ARE:
FRACTIONS XX ±0.000
DECIMALS .XX ±0.03 .XXX ±0.10
ANGLES ± 2°

HUSSMANN
DIAGRAM=R3/CR3-
P- 8R
3024014 | **G**

CIRCUIT #1
LOADING

120V	
110V	
200V	

LIGHT CIRCUIT= 14A 148W

LOWER FRONT SECTION

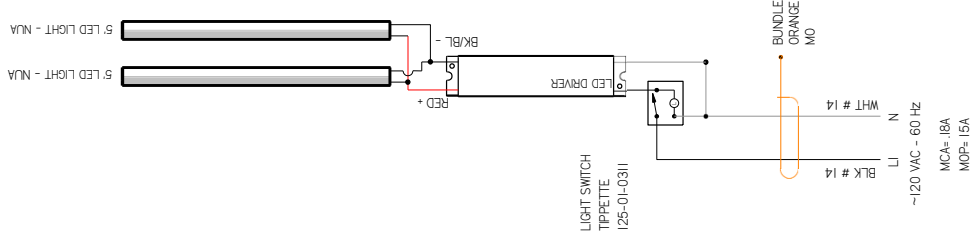

TOP SECTION

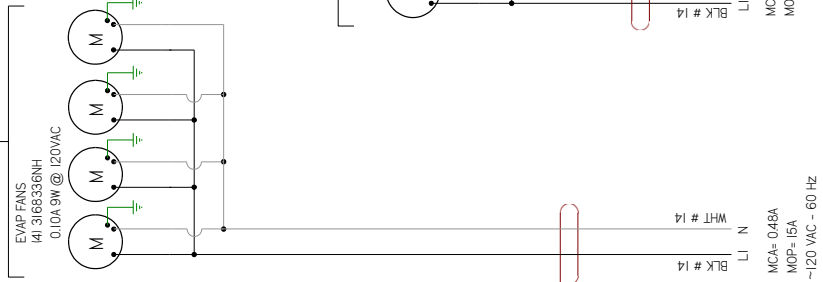

FRONT LOWER SECTION

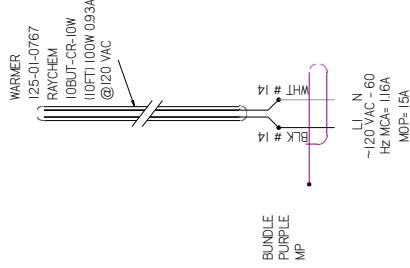
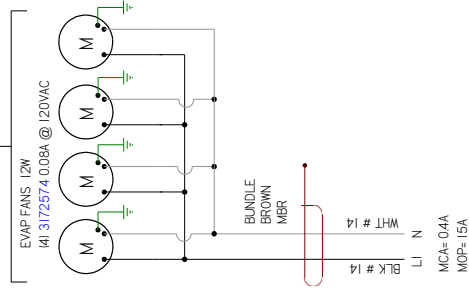

REV	ECN	DATE	REVISION DESCRIPTION	REV BY	CHKD BY	APPR BY
B	ECN-CAP-0006318	208/02/098	CHANGED 1-5' AT WIRING	CB	CB	CB
C	ECN-CAP-0007282	208/02/098	CHANGED HEATER	CB	CB	CB
D	ECN-COD-0015253	2022/02/09	NEW LIGHTS	AL	CB	CB
E	ECN-COD-0015253	2022/02/09	NEW FANS FN	AL	CB	CB
F	ECN-COD-0018145	2023/07/24	CHANGED EVAP FANS	CB	CB	CB
G	ECN-COD-0018715	2023/10/09	NEW FAN MOTOR	CB	CB	CB

HUSSMANN
DIAGRAM=R3/CR3-
P-10R

MATERIAL - N/A
DATE DRAWN - 1-26-17
DRAWN BY - CRAIG BOOREY
REVIEWED BY - CRAIG BOOREY
APPROVED BY - CRAIG BOOREY
UNLESS OTHERWISE SPECIFIED DIMENSIONS ARE IN INCHES.
TOLERANCES ARE:
DIMENSIONS .XX +0.3 .XXX
+0.0
ANGLES ± 2°

ECN-CAP-0005712
REF -
SHEET 1 OF 2
THIRD ANGLE PROJECTION

3024015 | G

NOTES:
CASE MUST BE GROUNDED
WHEN PASSING WIRES THROUGH METAL HOLES A GROMMET MUST BE USED

REV	ECN	DATE	REVISION DESCRIPTION	REV BY	CHKD BY	APPR BY
B	ECN-CAP-0006318	208/10/2018	CHANGED T-STAT WIRING	CB	CB	CB
C	ECN-CAP-0007282	208/10/2018	CHANGED HEATER	CB	CB	CB
D	ECN-COD-0015253	2022/02/09	NEW LIGHTS	AL	CB	CB
E	ECN-COD-0015253	2022/02/09	NEW FANS FPN	AL	CB	CB
F	ECN-COD-0018145	2023/07/24	CHANGED EMP FANS	CB	CB	CB
G	ECN-COD-0018175	2023/10/09	NEW FAN MOTOR	CB	CB	CB

OPTIONAL REAR STORAGE

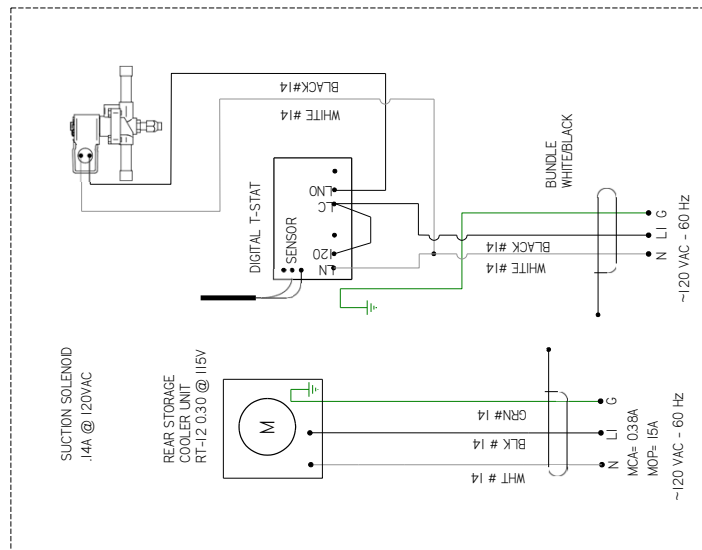

LOWER FRONT SECTION "OPTIONAL"

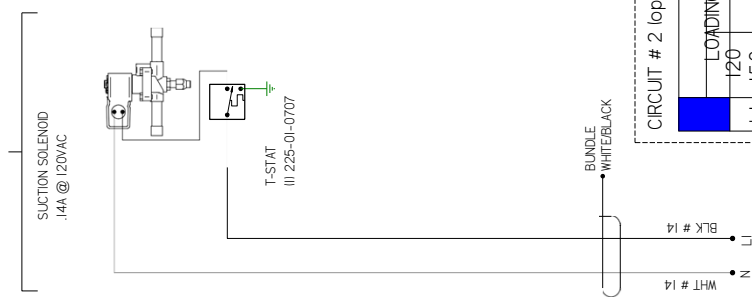

LIGHT CIRCUIT= J4A 14 BW

LOWER FRONT SECTION "OPTIONAL"

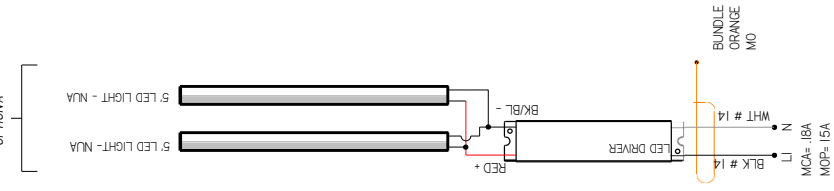

CIRCUIT # 2 (optional)

LOADING
120
150
V

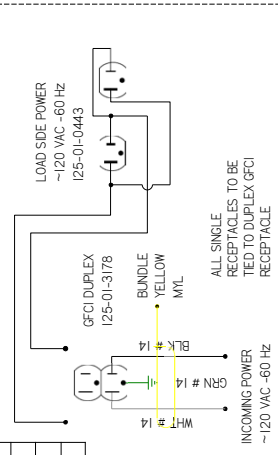

NOTE FOR GFCI PROTECTION IF MORE THAN ONE SINGLE RECEPTACLE IS USED IN CONJUNCTION WITH A GFCI DUPLEX RECEPTACLE, DOWNSTREAM ON THE LOAD SIDE, THE SUM OF ALL RECEPTACLES SHOULD NOT BE MORE THAN 15A

ALL SINGLE RECEPTACLES TO BE TIED TO DUPLEX GFCI RECEPTACLE

NOTES:
CASE MUST BE GROUNDED
WHEN PASSING WIRES THROUGH METAL HOLES A GROMMET MUST BE USED

HUSSMANN
DIAGRAM=R3/CR3-
P-10R

DATE DRAWN - 1-26-17
DRAWN BY - CRAIG BOOREY
REVIEWED BY - CRAIG BOOREY
APPROVED BY - CRAIG BOOREY
UNLESS OTHERWISE SPECIFIED DIMENSIONS ARE IN INCHES.
TOLERANCES ARE:
DECIMALS .XX +0.03, .XXX
ANGLES ± 2°

MATERIAL - N/A
ECON-CAP-0005712
REF -
SHEET 2 OF 2
THIRD
DIMENSIONS ARE IN INCHES.
TOLERANCES ARE:
DECIMALS .XX +0.03, .XXX
ANGLES ± 2°

3024015 | G

CIRCUIT #1
LOADING

120V			
20			

LIGHT CIRCUIT - 17A 16.6W

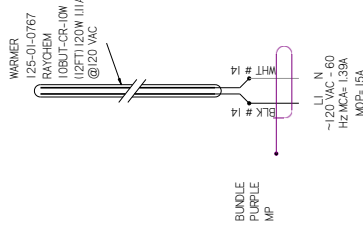
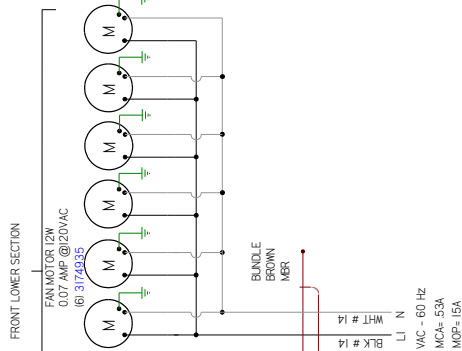
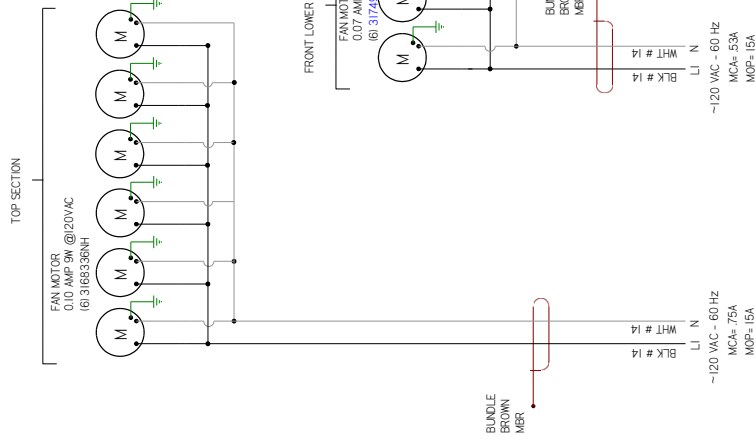
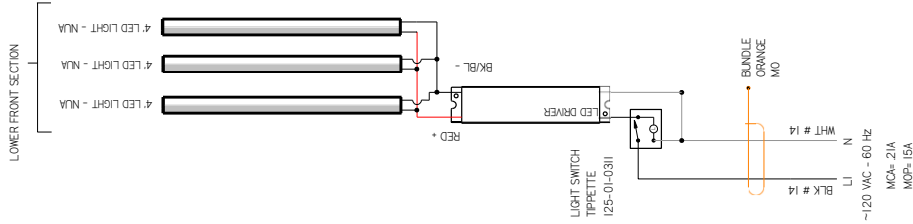

MATERIAL - N/A	
DATE DRAWN - 1-26-17	ECN-CAP-0005712
DRAWN BY - CRAIG BOOREY	REF -
REVIEWED BY - CRAIG BOOREY	SHEET 1 OF 2
UNLESS OTHERWISE SPECIFIED DIMENSIONS ARE IN INCHES.	
TOLERANCES ARE:	
DECIMALS .XX +03 .XXX	FRACTIONS
+0.0	ANGL
	E
	PROJECTION

HUSSMANN	
DIAGRAM=R3/CR3-	
P-12R	
3024017	
F	

NOTES:
CASE MUST BE GROUNDED
WHEN PASSING WIRES THROUGH METAL HOLES A GROMMET MUST BE USED

REVISION HISTORY

REV	ECN	DATE	REVISION DESCRIPTION	REV BY	CHKD BY	APPR BY
B	ECN-CAP-0006389	2017/02/08	CHANGED 1-5 STAT WIRING	CB	CB	CB
C	ECN-CAP-0007282	2017/03/24	CHANGED HEATER	CB	CB	CB
D	ECN-COD-0012953	2022/02/09	NEW LIGHTS	AL	CB	CB
E	ECN-COD-0018623	2023/02/07	NEW FANS PN	AL	CB	CB
F	ECN-COD-0018145	2023/07/24	CHANGED 6VWP FANS	CB	CB	CB

REV	ECN	DATE	REVISION DESCRIPTION	REV BY	CHKD BY	APPR BY
B	ECN-CAP-0006389	2017/02/08	CHANGED T-STAT WIRING	CB	CB	CB
C	ECN-CAP-0007282	2017/03/24	CHANGED HEATER	CB	CB	CB
D	ECN-COD-0018253	2022/02/09	NEW LIGHTS	AL	CB	CB
E	ECN-COD-0018623	2023/02/07	NEW FANS PM	AL	CB	CB
F	ECN-COD-0018145	2023/07/24	CHANGED EVAP FANS	CB	CB	CB

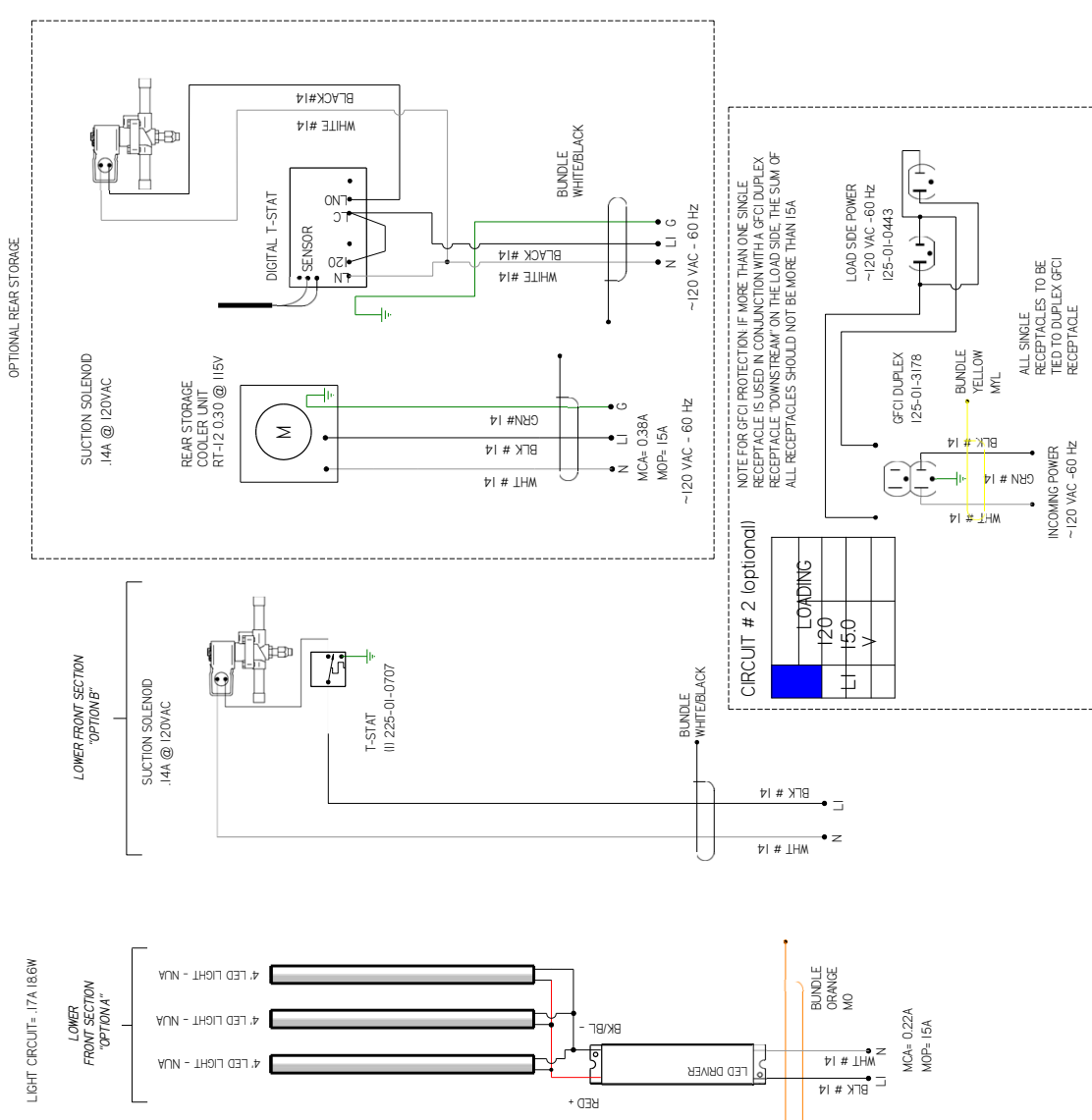

HUSSMANN
DIAGRAM=R3/CR3-P-12R

DATE DRAWN - 1-26-17
DRAWN BY - CRAIG BOOREY
REVIEWED BY - CRAIG BOOREY
APPROVED BY - CRAIG BOOREY

ECN-CAP-0005712
REF -
SHEET 2 OF 2

UNLESS OTHERWISE SPECIFIED DIMENSIONS ARE IN INCHES.
TOLERANCES ARE:
FRACTIONS .XX
DECIMALS .XX +03, .XXX
ANGLES ± 2°

PROJECTION

3024017 | F

NOTES:
CASE MUST BE GROUNDED
WHEN PASSING WIRES THROUGH METAL HOLES A GROMMET MUST BE USED

CIRCUIT #1

LOADING	120V		
	L1	0.54	

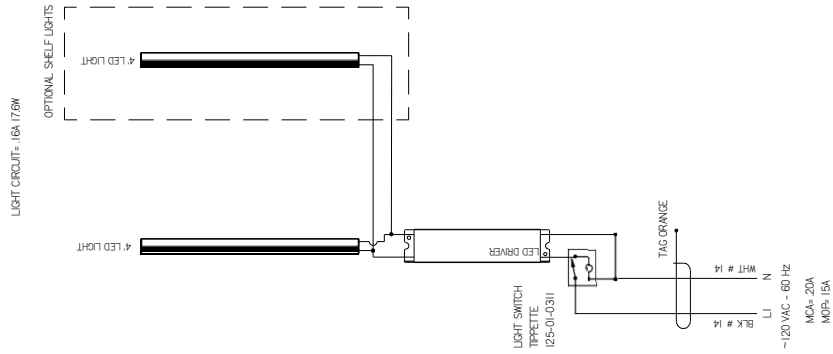

CIRCUIT # 2 optional

LOADING	120 V		
	L1	1.50	

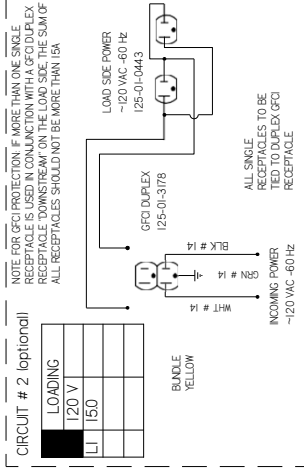

NOTE FOR GFCI PROTECTION IF MORE THAN ONE SINGLE RECEPTACLE IS USED IN CONJUNCTION WITH A GFCI DUPLEX RECEPTACLE, DOWNSTREAM ON THE LOAD SIDE, THE SUM OF ALL RECEPTACLES SHOULD NOT BE MORE THAN 15A.

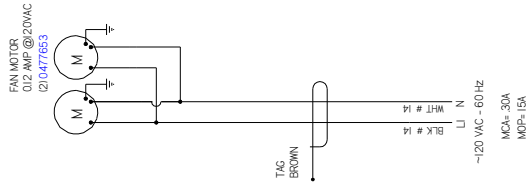

REV	EN	DATE	REVISION HISTORY	REV BY	CHKD BY	APPR BY
1	ECN-CAP-0004590	2/10/2011	RELEASED TO PRODUCTION	CB	GP	CB

MATERIAL - N/A

DATE DRAWN - 10-11-16

DRAWN BY - CRAIG BOOREY

REVIEWED BY - CRAIG BOOREY

APPROVED BY - CRAIG BOOREY

UNLESS OTHERWISE SPECIFIED DIMENSIONS ARE IN INCHES

TOLERANCES ARE

DECIMALS .XX ±0.3 .XXX ±0.1

ANGLES ± 2

PROJECTION

ANCL
E

3016886 | A

HUSSMANN
DIAGRAM R3/CR3 TO
-4-R

ECN-CAP-0004590

SHEET 1 OF 1

THIRD

HUSSMAN.LOCF.L1 SHEET SIZE D

NOTES:
CASE MUST BE GROUNDED
WHEN PASSING WIRES THROUGH METAL HOLES A GROMMET MUST BE USED

CIRCUIT #1

LOADING	120V			
	L1	0.75		

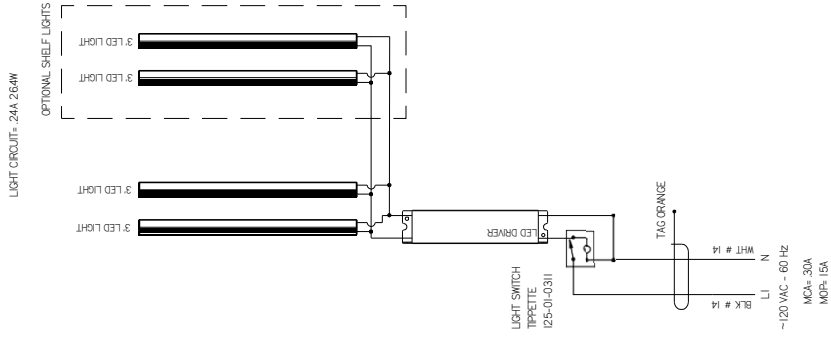

CIRCUIT #2 optional

LOADING	120V			
	L1	1.50		

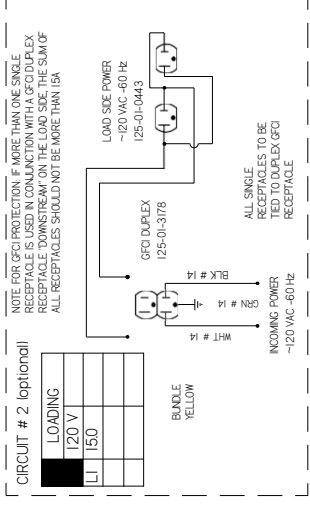

NOTE FOR GFCI PROTECTION IF MORE THAN ONE SINGLE RECEPTACLE IS USED IN CONJUNCTION WITH A GFCI DUPLEX RECEPTACLE, DOWNSTREAM ON THE LOAD SIDE, THE SUM OF ALL RECEPTACLES SHOULD NOT BE MORE THAN 15A.

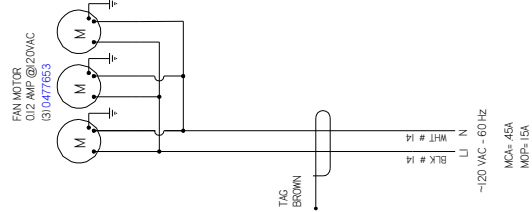

REV	EN	DATE	REVISION HISTORY
1	EN	2/10/2011	RELEASED TO PRODUCTION
			REV BY CHAD BY APPR BY
			CG

MATERIAL - N/A
 DATE DRAWN - 10-11-16
 DRAWN BY - CRAIG BOOREY
 REVIEWED BY - CRAIG BOOREY
 APPROVED BY - CRAIG BOOREY
 UNLESS OTHERWISE SPECIFIED DIMENSIONS ARE IN INCHES
 TOLERANCES ARE
 DECIMALS .XX ±0.3 .XXX
 ANGLES ± 2

HUSSMANN
 DIAGRAM R3/CR3-10
 -6-R

3016888 | A

ECN-CAP-0004590
 SHEET 1 OF 1
 THIRD ANCL
 PROJECTION

NOTES:
 CASE MUST BE GROUNDED
 WHEN PASSING WIRES THROUGH METAL HOLES A GROMMET MUST BE USED

CIRCUIT #1				
LOADING	120V			
	LI	0.95		

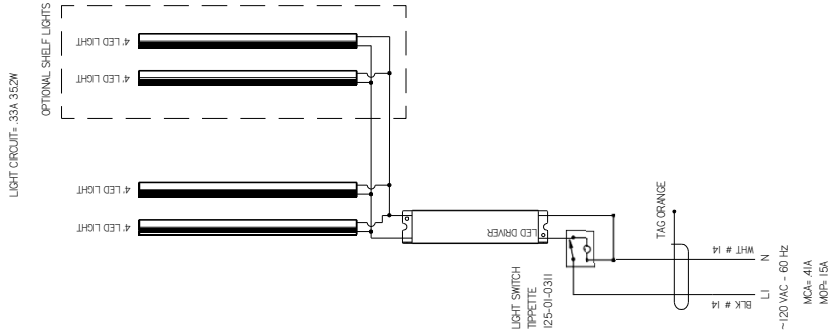

CIRCUIT #2				
LOADING	120V			
	LI	1.50		

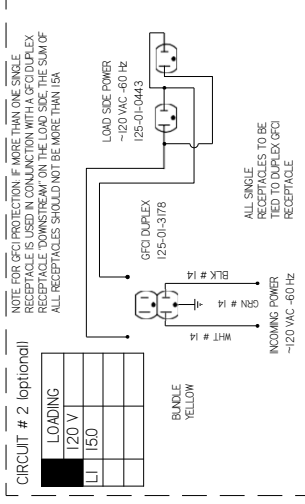

NOTE FOR GFCI PROTECTION: IF MORE THAN ONE SINGLE RECEPTACLE IS USED IN CONJUNCTION WITH A GFCI DUPLEX RECEPTACLE, DOWNSTREAM ON THE LOAD SIDE, THE SUM OF ALL RECEPTACLES SHOULD NOT BE MORE THAN 15A.

REV	EN	DATE	REVISION HISTORY
1	EN	2/20/2011	RELEASED TO PRODUCTION
			REV BY / CHD BY / APPR BY
			CG / GP / CG

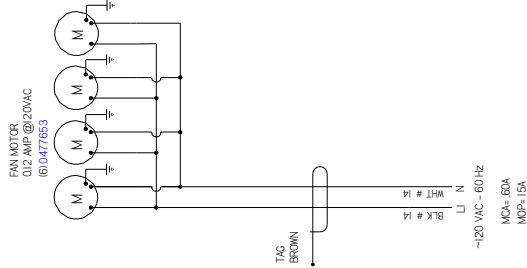

HUSSMANN
DIAGRAM R3/CR3-10
-8-R

MATERIAL - N/A
DATE DRAWN - 10-11-16
DRAWN BY - CRAIG BOOREY
REVIEWED BY - CRAIG BOOREY
APPROVED BY - CRAIG BOOREY
SHEET 1 OF 1
UNLESS OTHERWISE SPECIFIED DIMENSIONS ARE IN INCHES
TOLERANCES ARE:
DECIMALS .XX ±0.3 .XXX
±0.0 ANGL
E
PROJECTION

3016889 | A

NOTES:
CASE MUST BE GROUNDED
WHEN PASSING WIRES THROUGH METAL HOLES A GROMMET MUST BE USED

HUSSMANN_C03F11_SHEET_SIZE D

CIRCUIT #1
LOADING

120V			
L1	10		

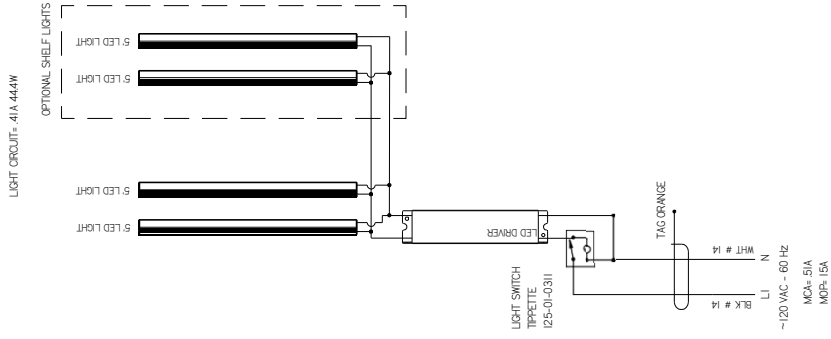

OPTIONAL SHELF LIGHTS



CIRCUIT # 2 optional

LOADING			
L1	150		

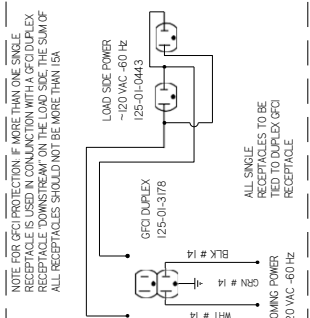

NOTE FOR GFCI PROTECTION IF MORE THAN ONE SINGLE RECEPTACLE IS USED IN CONJUNCTION WITH A GFCI DUPLEX RECEPTACLE, DOWNSTREAM ON THE LOAD SIDE, THE SUM OF ALL RECEPTACLES SHOULD NOT BE MORE THAN 15A.

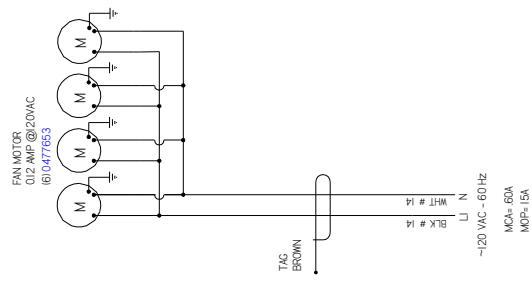

REV	EN	DATE	REVISION HISTORY
1	EN	2/10/2011	RELEASED TO PRODUCTION
			REV BY CHAD BY APPR BY
			CG

HUSSMANN
DIAGRAM R3/CR3 TO
-10-R

MATERIAL - N/A
DATE DRAWN - 10-11-16
DRAWN BY - CRAIG BOOREY
REVIEWED BY - CRAIG BOOREY
APPROVED BY - CRAIG BOOREY
SHEET 1 OF 1
UNLESS OTHERWISE SPECIFIED DIMENSIONS ARE IN INCHES
TOLERANCES ARE
DECIMALS .XX ±0.3 .XXX
±0.0
ANCL
E
PROJECTION

3016890 | A

NOTES:
CASE MUST BE GROUNDED
WHEN PASSING WIRES THROUGH METAL HOLES A GROMMET MUST BE USED

CIRCUIT #1
LOADING

120V			
L1	14		

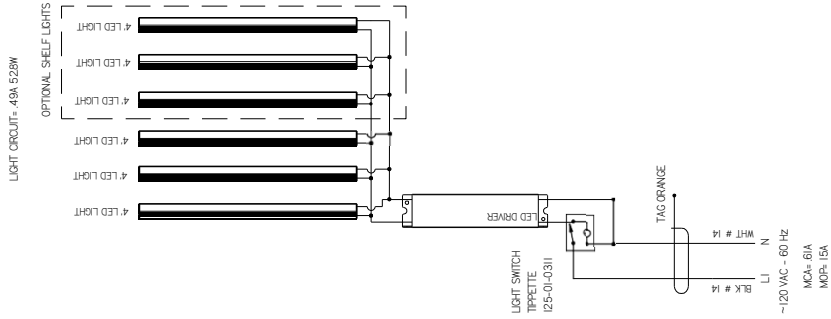

REVISION HISTORY

REV	EN	DATE	REVISION DESCRIPTION	REV BY	CHKD BY	APPROV BY
X	ESL-CAP-0004590	2/10/2011	RELEASED TO PRODUCTION	ES	GP	GP

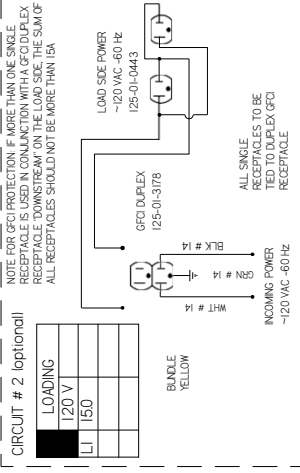

LOADING

120 V			
L1	150		

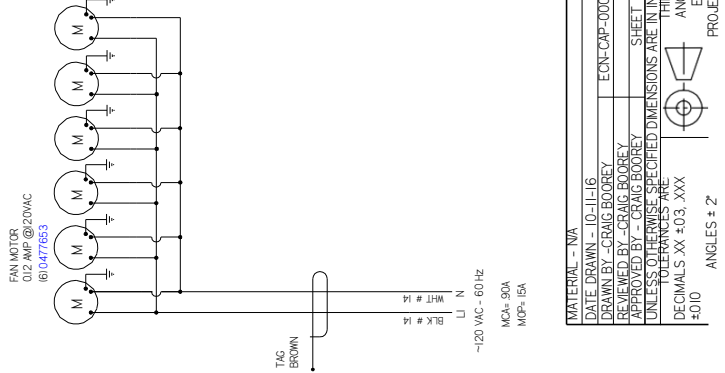

MATERIAL - N/A

DATE DRAWN - 10-11-16

DRAWN BY - CRAIG BOOREY

REVIEWED BY - CRAIG BOOREY

APPROVED BY - CRAIG BOOREY

SHEET 1 OF 1

UNLESS OTHERWISE SPECIFIED DIMENSIONS ARE IN INCHES

TOLERANCES ARE

DECIMALS .XX ±0.3 .XXX ±0.1

ANGLES ± 2°

PROJECTION

HUSSMANN
DIAGRAM R31CR3 TO
-12-R

3016891 | A

NOTES:
CASE MUST BE GROUNDED
WHEN PASSING WIRES THROUGH METAL HOLES A GROMMET MUST BE USED

12. Troubleshooting Guide

Problem	Possible Cause	Possible Solution
Case temperature is too warm.	Ambient conditions may be affecting the case operation.	Check case position in store. Is the case located near an open door, window, electric fan or air conditioning vent that may cause air currents? Case must be located minimum 15 Ft away from doors or windows. Cases are designed to operate at 55% Relative humidity and a temperature of 75°F.
	Discharge air temp is out of spec.	Check evaporator fan operation. Check electrical connections and input voltage.
		Fans are installed backwards. Check airflow direction.
		Fan blades are installed incorrectly. Make sure fan blades have correct pitch and are per specification.
		Check to see that fan plenum is installed correctly. It should not have any gaps.
		Check suction pressure and insure that it meets factory specifications.
	Case is in defrost.	Check defrost settings. See Technical Specifications section.
	Product load may be over its limits blocking airflow.	Redistribute product so it does not exceed load level. There is a sticker on the inside of the case indicating what the maximum load line is.
	Coil is freezing over.	Return air is blocked, make sure debris is not blocking the intake section.
Coil close-offs are not installed. Inspect coil to make sure these parts are on the case.		
Condensing coil or evaporator coil is clogged or dirty.	Clean coil.	
Case temperature is too cold.	The t-stat temp is set too low.	Check settings. See Technical Specifications section.
	Ambient conditions may be affecting the case operation.	Check case position in store. Is the case located near an open door, window, electric fan or air conditioning vent that may cause air currents? Case must be located minimum 15 Ft away from doors or windows. Cases are designed to operate at 55% Relative humidity and a temperature of 75°F.
Condensation on glass.	Ambient conditions may be affecting the case operation.	Check case position in store. Is the case located near an open door, window, electric fan or air conditioning vent that may cause air currents? Case must be located minimum 15 Ft away from doors or windows. Cases are designed to operate at 55% Relative humidity and a temperature of 75°F.
	Inadequate air circulation.	Check if air sweep fans are functioning, check electrical connections.
	There is not enough heat provided in the airflow.	Check if air sweep heater is functioning, check electrical connections.
	There are glass gaps on the side of the case.	See glass adjustment section.
	Glass is not completely shut.	Close glass correctly.

Troubleshooting Guide (Cont'd)

Problem	Possible Cause	Possible Solution
Water has pooled under case.	Case drain is clogged.	Clear drain.
	PVC drains under case may have a leak.	Repair as needed.
	Case tub has unsealed opening.	Seal as needed.
	If the case is in a line-up, case to case joint is missing or unsealed.	Install case to case joint and seal as needed.
	Evaporator pan is overflowing (if applicable).	Check electrical connection to evaporator pan. Check float assembly, it should move freely up and down the support stem. Clear any debris.
Case is not draining properly.	Case is not level.	Level the case.
	Drain screen is plugged.	Clean drain screen and remove any debris.
	Drain or P-trap is clogged.	Clear any debris.
Frost or ice on evaporator coil.	Evaporator fans are not functioning.	Check electrical connections.
	Defrost clock is not functioning.	Case should be serviced by a qualified service technician.
	Coil is freezing over.	Return air is blocked, make sure debris is not blocking the intake section.
Coil close-offs are not installed. Inspect coil to make sure these parts are on the case.		
Large gap is visible on bottom of front glass or glass can't be opened because it is too low.	Glass Height adjusters need to be adjusted.	See Glass Adjustment section.
Large gaps are visible in between glass panels or glass rubs against end panel.	Glass/glass clamp assembly needs to be adjusted.	See Glass Adjustment section.
Front glass does not stay open and falls closed.	Glass shock/piston may need to be replaced.	Case should be serviced by a qualified service technician.
Lights do not come on.	LED Driver/light socket wiring.	Check electrical connections. See Electrical Section and check wiring diagram.
	LED Driver needs to be replaced.	Case should be serviced by a qualified service technician. See Electrical Section.
	Lamp socket needs to be replaced.	Case should be serviced by a qualified service technician.
	Lamp needs to be replaced.	See Maintenance Section.
	Light Switch needs to be replaced.	Case should be serviced by a qualified service technician.

For further technical information, please log on to http://www.husmann.com/products/R3D_R3P_R3TO.htm



This warning does not mean that Hussmann products will cause cancer or reproductive harm, or is in violation of any product-safety standards or requirements. As clarified by the California State government, Proposition 65 can be considered more of a ‘right to know’ law than a pure product safety law. When used as designed, Hussmann believes that our products are not harmful. We provide the Proposition 65 warning to stay in compliance with California State law. It is your responsibility to provide accurate Proposition 65 warning labels to your customers when necessary. For more information on Proposition 65, please visit the California State government website.