

We reserve the right to change or revise specifications and product design in connection with any feature of our products. Such changes do not entitle the buyer to corresponding changes, improvements, additions or replacements for equipment previously sold or shipped.

Item	Part #	Description	Wiring	Item	Part #	Description	Wiring
<b>FAN ASSEMBLIES</b>				<b>LAMPS AND BALLASTS</b>			
<b>8 Ft &amp; 12 Ft</b>				D.	Ballast, Electronic		(4)
A.	<b>12W Standard Energy Efficient Fan Assembly</b>	(1)		0480130	2 lamps		
	0477655	Fan Motor, Evaporator		0480131	3 lamps		
	0461805	Fan Blade		0480132	4 lamps		
<b>6 Ft Only</b>				E.	Fluorescent Lamp		(5)
A.	<b>7W Standard Energy Efficient Fan Assembly</b>	(1)		<i>Replace with like fixtures</i>			
	0477654	Fan Motor, Evaporator		<b>LED FIXTURES AND POWER SUPPLY</b>			
	0142780	Fan Blade		F.	0501213	Power Supply	(6)
<b>THERMOSTATS</b>				G.	LED Canopy Fixture		(7)
B.	Optional Adjustable Refrigeration Thermostat	(2)		<i>Replace with like fixtures</i>			
<b>HEATERS</b>				H.	LED Shelf Fixture		(8)
C.	Canopy Anti-Sweat Heater	(3)		<i>Replace with like fixtures</i>			
	0488622	6 ft					
	0488623	8 ft					
	0488624	12 ft					

Datasheet-Excel-C3X-LGEP

Note: Revision N: April 2017. Updated LED energy values. Other changes marked with a bar, circle or underline.

# Engineering Plan Views

PHYSICAL DATA	
Merchandiser Drip Pipe (in.)	1 1/4
Merchandiser Liquid Line (in.)	3/8
Merchandiser Suction Line (in.)	7/8

## Dairy/Delicatessen Precut & Packaged Produce

Dimensions shown as inches and (mm).

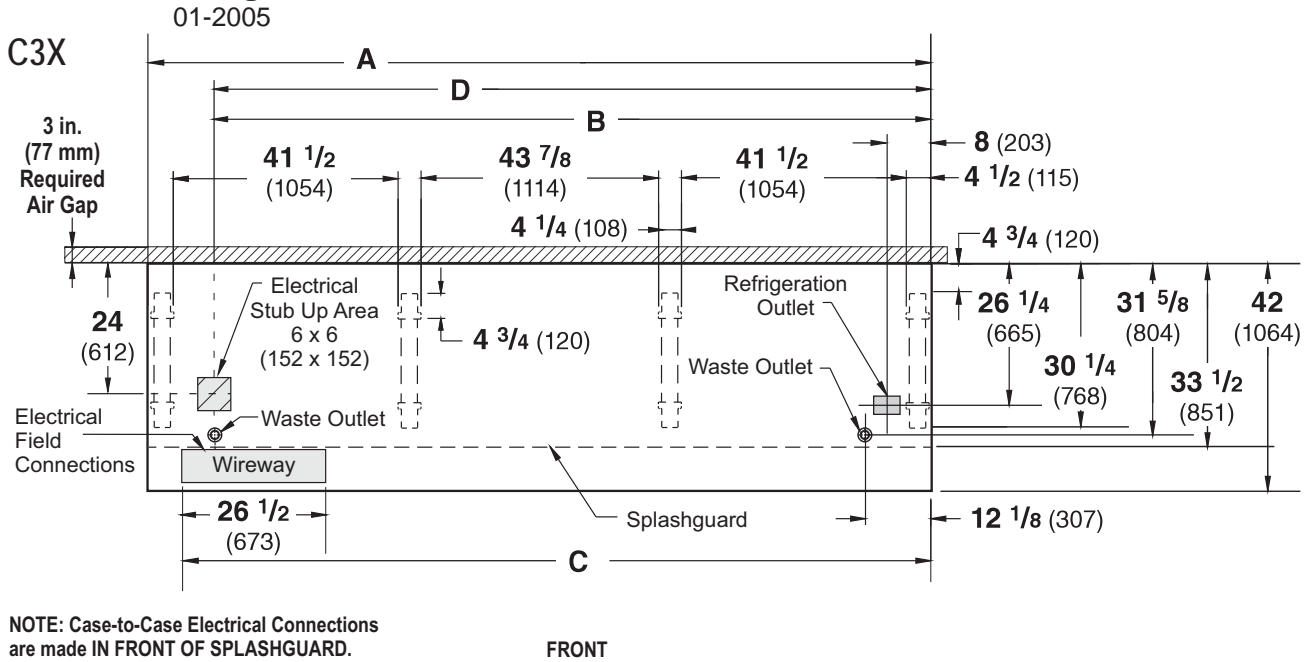

	6 ft	8 ft	12 ft
<b>General</b>			
<b>(A)</b> Case Length (without ends or partitions) (Each end and insulated partition adds 1 1/2 in. (38 mm) to case line up.) Maximum O/S dimension of case back to front (includes bumper)	72 3/8 (1838)	96 3/8 (2448)	144 1/2 (3670)
Back of case to front of splashguard	42 (1064)	42 (1064)	42 (1064)
Back of case to O/S edge of front leg	33 1/2 (851)	33 1/2 (851)	33 1/2 (851)
Distance between edges of external legs and center legs	30 1/4 (768)	30 1/4 (768)	30 1/4 (768)
Distance between edges of center legs	29 1/2 (750)	41 1/2 (1054)	41 1/2 (1054)
Distance between front legs and splashguard	NA	NA	43 7/8 (1114)
	2 3/4 (70)	2 3/4 (70)	2 3/4 (70)
<b>Electrical Service</b> (Electrical Field Wiring connection point)			
<b>(B)</b> RH End of case to center of stub up area	60 1/4 (1530)	84 1/4 (2140)	132 3/8 (3363)
Back of case to center of stub up area	24 (612)	24 (612)	24 (612)
Length of electrical wireway	26 1/2 (673)	26 1/2 (673)	26 1/2 (673)
<b>(C)</b> RH End of case to LH end of wireway	66 1/8 (1680)	90 1/8 (2289)	138 1/4 (3511)
<b>Waste Outlets</b> (One each end)			
<b>(D)</b> RH End of case to the center of LH waste outlet	60 1/4 (1530)	84 1/4 (2140)	132 3/8 (3363)
RH End of case to the center of RH waste outlet	12 1/8 (307)	12 1/8 (307)	12 1/8 (307)
Back O/S of case to center of waste outlets	31 5/8 (804)	31 5/8 (804)	31 5/8 (804)
Schedule 40 PVC drip pipe	1 1/4 (32)	1 1/4 (32)	1 1/4 (32)
<b>Refrigeration Outlet</b>			
Back of case to center of refrigeration outlet	26 1/4 (665)	26 1/4 (665)	26 1/4 (665)
RH end of case to center of refrigeration outlet	8 (203)	8 (203)	8 (203)

Multi-deck, 4 Display Levels, Low Front with Glass



Hussmann refrigerated merchandisers configured for sale for use in the United States meet or surpass the requirements of the DOE 2017 energy efficiency standards.

Dimensions shown as inches and (mm).

**C3X-LGEP**

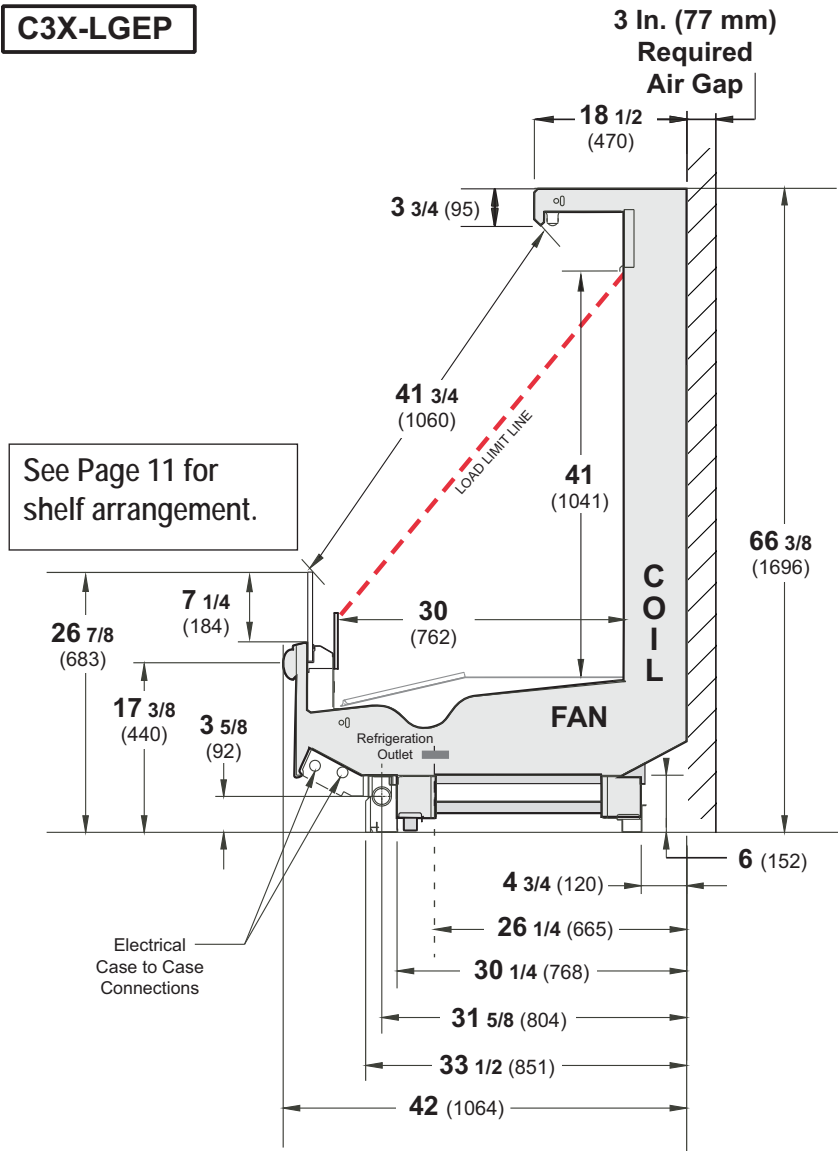

**Excel C3X-LGEP**  
Dairy / Delicatessen  
Precut and Packaged Produce

**REFRIGERATION DATA**

Note: This data is based on store temperature and humidity that does not exceed 75°F and 55% R.H.

C3X-LGEP <sup>§</sup>	Unlit	Lit
Discharge Air °F	32	30
Evaporator °F	28	26
Unit Sizing °F	26	24

§ Average evaporator temperature shown. Use dew point for high glide refrigerants for unit sizing. Care should be taken to use the dew point in PT tables for measuring and adjusting superheat. Adjust evaporator pressure as needed to maintain discharge air temperature shown.

*Btu/hr/ft — Unlit Shelves<sup>‡</sup>*

C3X-LGEP	Parallel	Conventional
UNLIT	1118	1193

<sup>‡</sup> Add 10 Btu/hr/ft *per shelf row* for LED fixtures.  
Add 20 Btu/hr/ft *per shelf row* for fluorescent lamps.

**DEFROST DATA**

	C3X-LGEP
Frequency (hr)	8
Defrost Water (lb/ft/day)	6
(±15% based on case configuration and product loading.)	
<b>OFFTIME</b>	<b>C3X-LGEP</b>
Failsafe Minutes	30
<b>ELECTRIC OR GAS</b>	Not Recommended

**CONVENTIONAL CONTROLS**

Low Pressure Backup Control	C3X-LGEP
CI/CO*	19°F / 9°F

**Indoor Unit Only, Pressure Defrost**

Termination*	48°F
*Use a Temperature Pressure Chart to determine PSIG conversions.	

**NSF Certification**

This merchandiser model is manufactured to meet NSF/ANSI (National Sanitation Foundation) Standard #7 requirements for construction, materials & cleanability.

**Estimated Charge (lb)\*\*C3X-LGEP**

6 ft	2.8
8 ft	3.7
12 ft	5.1

\*\*This is an average for all refrigerant types. Actual refrigerant charge may vary by approximately half a pound (8 oz/0.2 kg).

<b>Excel C3X-LGEP</b> <b>Dairy / Delicatessen</b> <b>Precut and Packaged Produce</b>
--

**Electrical Data**

	<b>6 ft</b>	<b>8 ft</b>	<b>12 ft</b>		<b>6 ft</b>	<b>8 ft</b>	<b>12 ft</b>
<b>Number of Fans—12W</b>	—	2	3				
<b>Number of Fans—7W</b>	2	—	—				
		<b>Amperes</b>			<b>Watts</b>		
	<b>6 ft</b>	<b>8 ft</b>	<b>12 ft</b>		<b>6 ft</b>	<b>8 ft</b>	<b>12 ft</b>
<b>Evaporator Fan</b>							
120V 50/60Hz Standard Energy Efficient	0.38	0.60	0.90		28	36	54
230V 50/60Hz Standard Energy Efficient	0.20	0.30	0.45		28	36	54
230V 60Hz Export	0.50	0.66	0.99		78	100	150
230V 50Hz Export	0.56	0.76	1.14		84	114	171
<b>Minimum Circuit Ampacity</b>							
120V 50/60Hz Standard Energy Efficient	0.58	0.80	1.10				
230V 50/60Hz Standard Energy Efficient	0.40	0.50	0.65				
230V 60Hz Export	0.70	0.86	1.19				
230V 50Hz Export	0.76	0.96	1.34				
<b>Maximum Over Current Protection 120V</b>	<b>20</b>	<b>20</b>	<b>20</b>				
<b>Maximum Over Current Protection 230V</b>	<b>15</b>	<b>15</b>	<b>15</b>				
<b>Anti-sweat Heaters</b>							
120V 50/60Hz Standard	0.15	0.20	0.30		18	24	36
<b>Standard Lighting (T-8 Fluorescent)</b>							
1 Row Canopy	0.51	0.51	0.77		59	59	85
<b>ONLY LIGHTING CONFIGURATIONS THAT ARE COMPLIANT WITH THE U.S. DEPT. OF ENERGY (DOE) 2017 REGULATION ARE AVAILABLE FOR SALE FOR USE IN THE U.S.A.</b>							
<b>Optional Lighting (T-8 Fluorescent)</b>							
Additional 1 Row Canopy	0.51	0.51	0.77		59	59	85
1 Row Rail Light	NA — Glass front does not accept rail light						
1 Row of Shelves	0.51	0.51	0.77		59	59	85
2 Rows of Shelves	1.02	1.02	1.54		118	118	170
3 Rows of Shelves	1.53	1.53	2.31		177	177	255
<b>EcoShine II Canopy</b>							
EcoShine II	0.24	0.32	0.48		28.9	38.6	58.0
EcoShine II HO	0.33	0.44	0.66		39.5	53.0	79.4
<b>EcoShine II Shelves</b>							
1 Row of Shelves	0.12	0.16	0.25		14.1	19.8	29.7
2 Rows of Shelves	0.23	0.33	0.49		28.2	39.5	59.3
3 Rows of Shelves	0.35	0.49	0.74		42.3	59.3	89.0

120V Lighting Circuit Total = Standard Lighting + Total Optional Lighting + Optional Shelf Lighting  
 120V LED Lighting Circuit Total = Canopy Lighting + Shelf Lighting  
 230V Lighting Circuit Total = Multiply 120V Lighting Circuit Total by 0.52

*Please note: some combinations of fluorescent lights on this case model may not be compliant with DOE 2017 and may not be available to order in the US and Canada. More lighting options are available with LED lights. The Hussmann Product Configurator will not allow lighting options that do not comply with the DOE 2017 standards.*

**Product Data**

<i>Recommended Usable Cube</i> <sup>1</sup> (Cu Ft/Ft)	4.77 ft <sup>3</sup> /ft (0.44 m <sup>3</sup> /m)
<i>AHRI Total Display Area</i> <sup>2</sup> (Sq Ft/Ft)	4.02 ft <sup>2</sup> /ft (1.23 m <sup>2</sup> /m)
<i>Shelf Area</i> <sup>3</sup> (Sq Ft/Ft)	6.02 ft <sup>2</sup> /ft (1.84 m <sup>2</sup> /m)

<sup>1</sup> AHRI Refrigerated Volume less shelving and other unusable space: Refrigerated Volume/Unit of Length, ft<sup>3</sup>/ft [m<sup>3</sup>/m]  
<sup>2</sup> Computed using AHRI 1200 standard methodology: Total Display Area, ft<sup>2</sup> [m<sup>2</sup>]/Unit of Length, ft [m]  
<sup>3</sup> Shelf surface area is composed of bottom deck plus standard shelf complement, as shown in the Hussmann *Product Reference Guide*. The standard shelf complement for this model is (1) row of 12-inch shelf, (1) row of 14-inch shelf and (1) row of 16-inch shelf.

<b>ESTIMATED SHIPPING WEIGHT <sup>4</sup></b>				
Case				Solid End
	<i>6 ft</i>	<i>8 ft</i>	<i>12 ft</i>	<i>(each)</i>
<b>lb (kg)</b>	800 (363)	1000 (454)	1200 (544)	100 (45)

<sup>4</sup> Actual weights will vary according to optional kits included.

# Fan Wiring Offtime Defrost

## 2 & 3 Fans

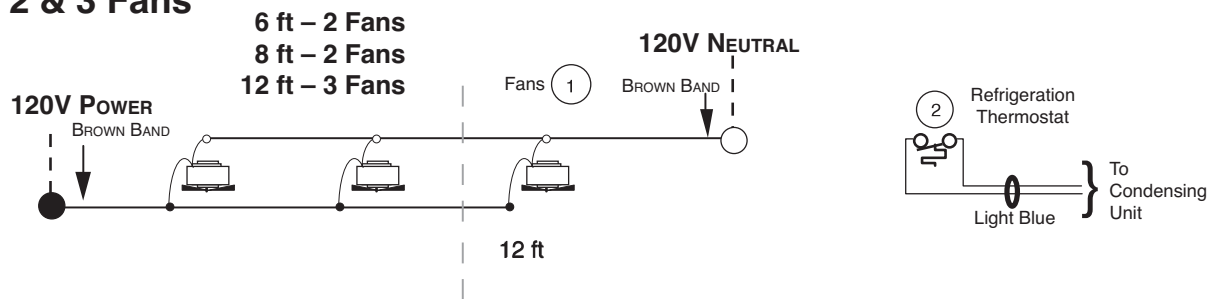

# Canopy Light Circuits — Fluorescent Fixtures

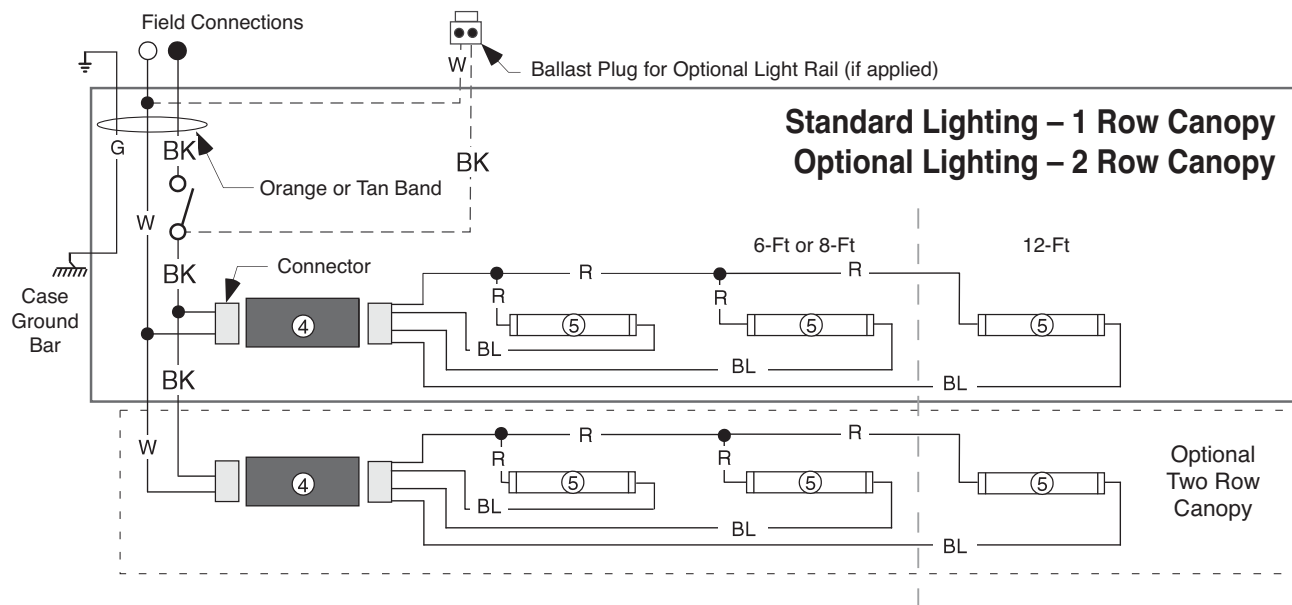

## WARNING

All components must have mechanical ground, and the merchandiser must be grounded.

CIRCLED NUMBERS = PARTS LIST ITEM NUMBERS

R = Red    Y = Yellow    G = Green    BL = Blue    BK = Black    W = White

● = 120V POWER    ○ = 120V NEUTRAL    ⊥ = FIELD GROUND    ≡ = CASE GROUND

# Canopy Anti-Sweat Heater

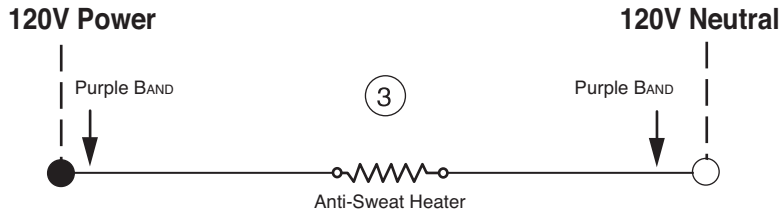

# Optional Shelf Lighting Fluorescent Fixtures

## Optional Shelf Harness and Light Circuits for Three Rows of Shelves

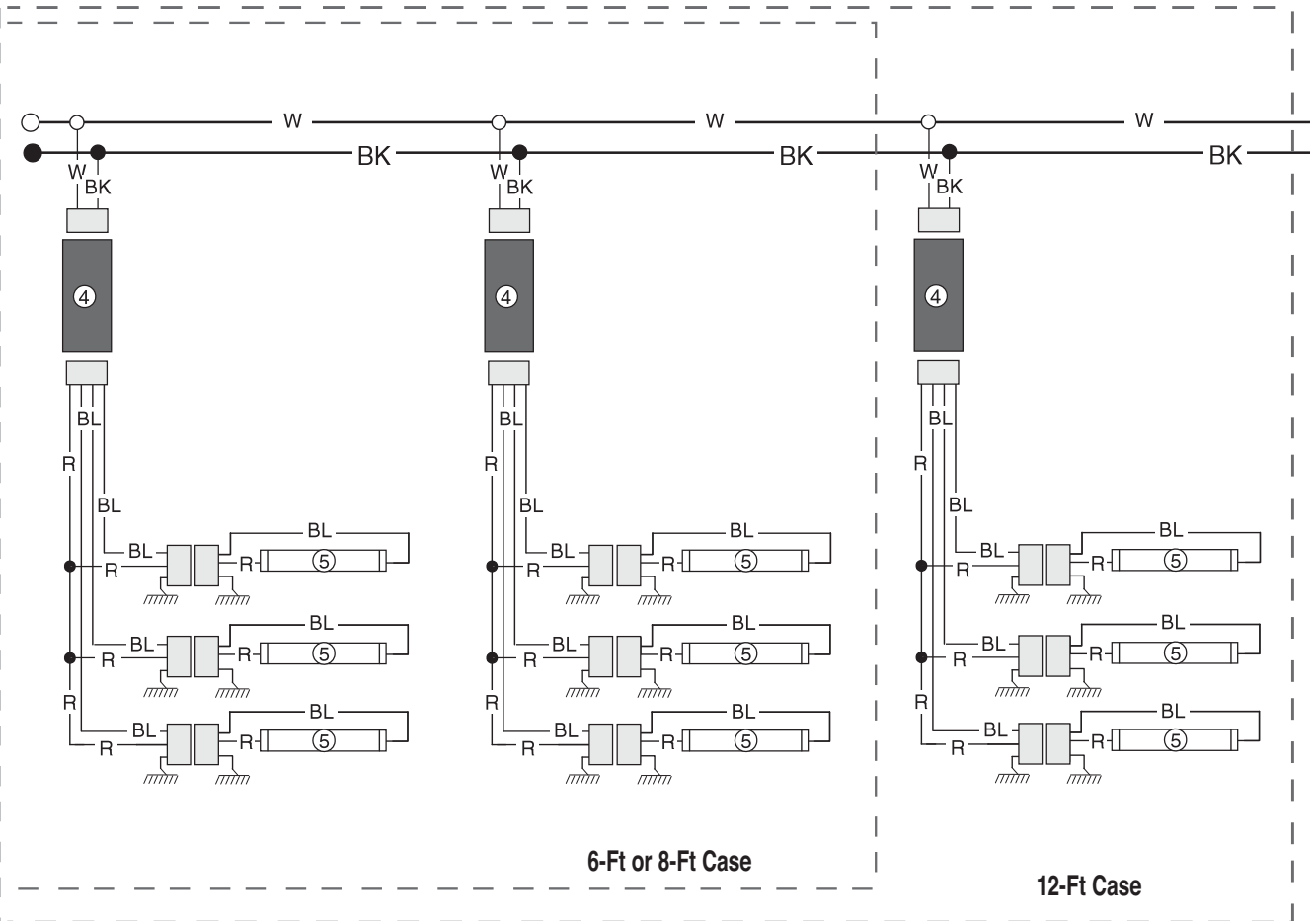

### WARNING

All components must have mechanical ground, and the merchandiser must be grounded.

CIRCLED NUMBERS = PARTS LIST ITEM NUMBERS

R = Red    Y = Yellow    G = Green    BL = Blue    BK = Black    W = White  
 ● = 120V POWER    ○ = 120V NEUTRAL    ⏏ = FIELD GROUND    ⏏ = CASE GROUND

# Optional Canopy Light Circuits — LED Fixtures

## EcoShine II LED Canopy Lighting – 1 Row

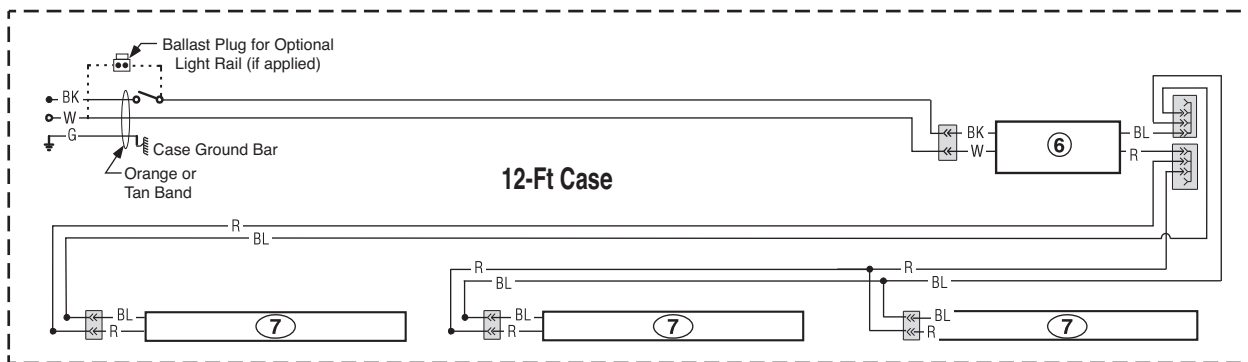
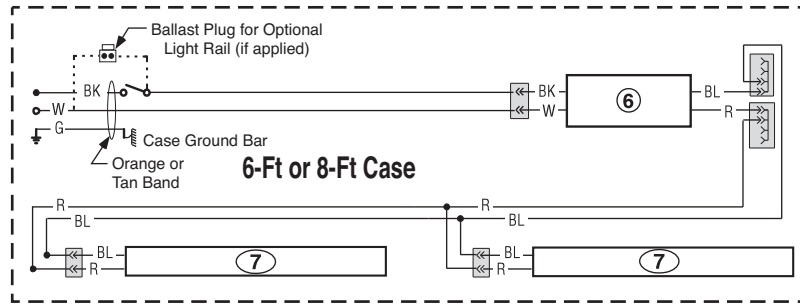

### WARNING

All components must have mechanical ground, and the merchandiser must be grounded.

CIRCLED NUMBERS = PARTS LIST ITEM NUMBERS

R = Red    Y = Yellow    G = Green    BL = Blue    BK = Black    W = White

● = 120V POWER    ○ = 120V NEUTRAL    ⚡ = FIELD GROUND    ⏏ = CASE GROUND

# Optional Shelf Lighting LED Fixtures

## Optional Shelf Harness and LED Light Circuits for 2 or 3 Rows of Shelves

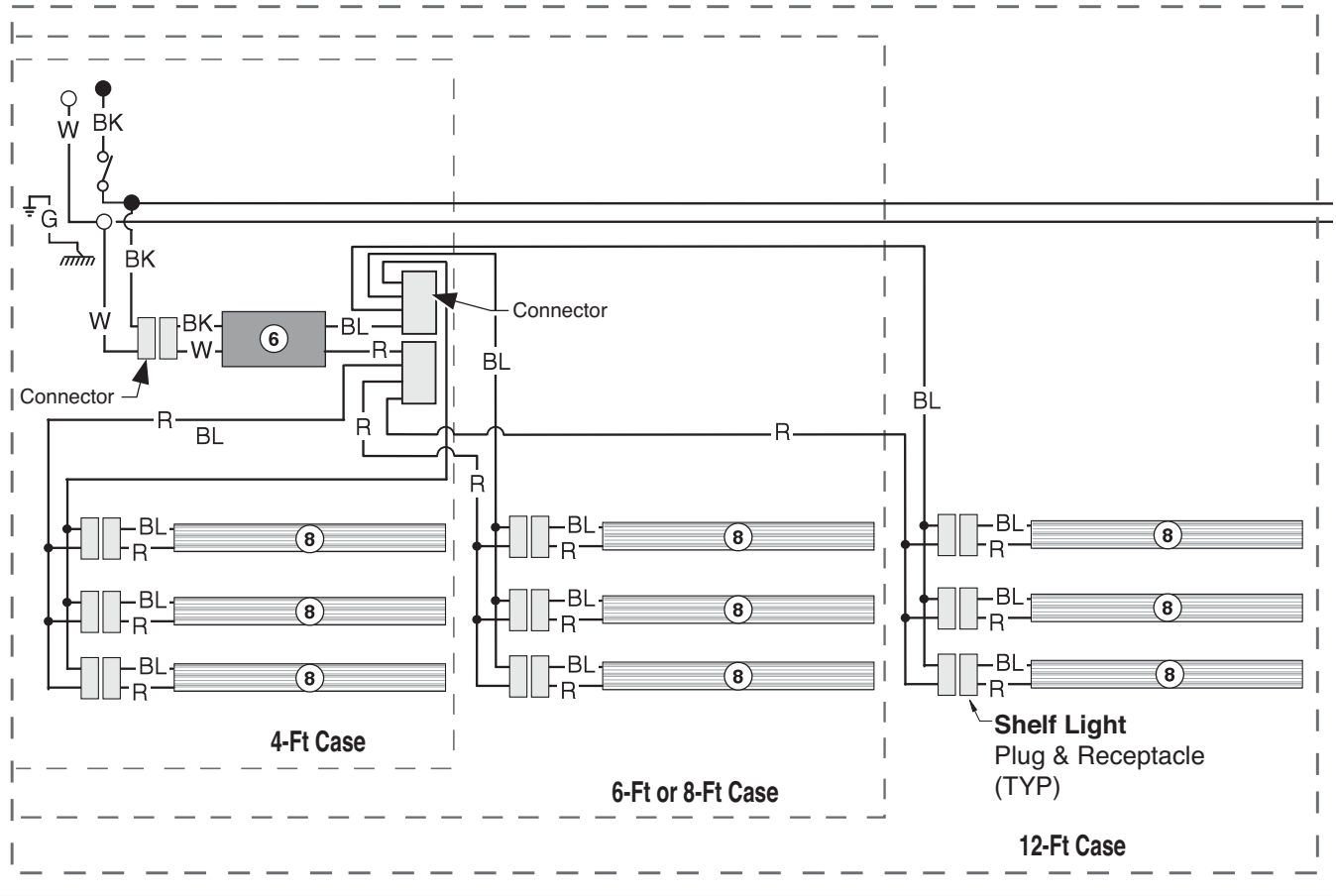

### WARNING

All components must have mechanical ground, and the merchandiser must be grounded.

CIRCLED NUMBERS = PARTS LIST ITEM NUMBERS

R = Red      G = Green      BL = Blue      BK = Black      W = White

● = 120V POWER      ○ = 120V NEUTRAL      ⚡ = FIELD GROUND      mm = CASE GROUND

## Excel **C3X-LGEP**

**Dairy/Delicatessen**

**Precut & Packaged Produce**

The ballast for the canopy and shelf lamps is located behind the canopy on the left-hand end (when facing case) of the merchandiser.

To access the ballast:

1. Remove screws at bottom edge of canopy and rear of light channel.
2. Lower light channel which will pivot on hinge.
3. Service or replace ballasts as required.
4. Reassemble items as they were originally installed.

**NOTE:** Rail lamp ballast is located in the electrical raceway.

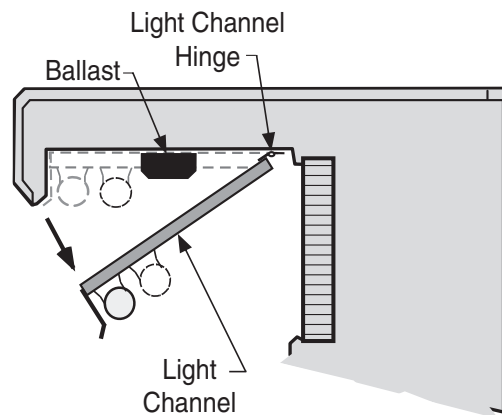
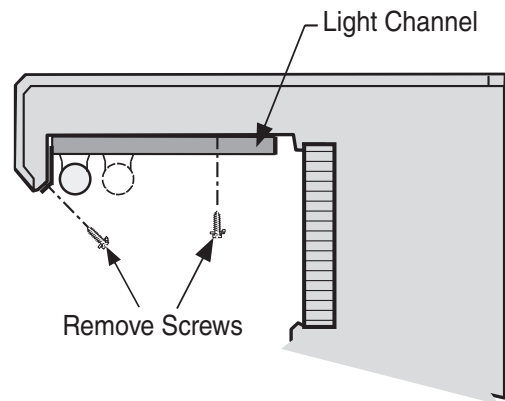

## **CANOPY ANTI-SWEAT HEATER**

The canopy anti-sweat heater location is shown below. Connections are in the electrical wireway.

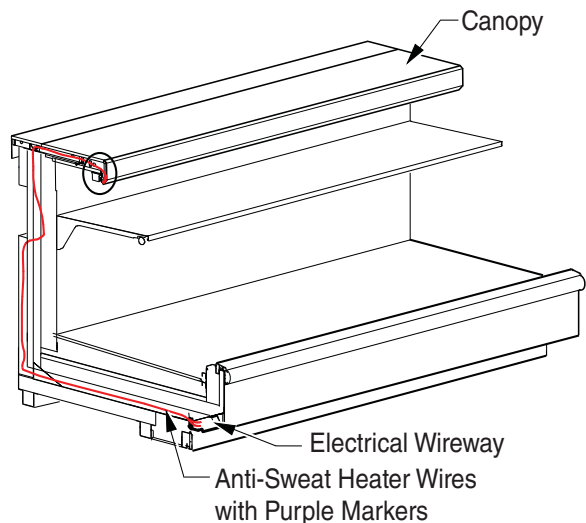
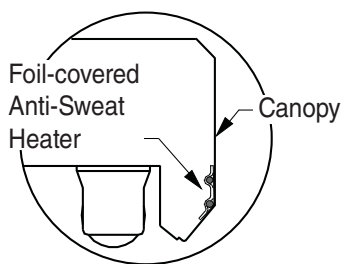

## SHELF CONFIGURATION

This case is designed for three (3) shelves.

The depth of the shelves used are critical to case performance.

The use of peg shelves is NOT recommended on C3X-LGEP cases. Depth and angle requirements are listed below.

<b>Top Shelf</b>	
Shelf Depth	Shelf Angle
12 inches	0°,10°,15°,30°,45°
14 inches	30°,45°

<b>Second Shelf</b>	
Shelf Depth	Shelf Angle
14 inches	0°,10°,15°,30°,45°
16 inches	30°,45°

<b>Third Shelf</b>	
Shelf Depth	Shelf Angle
16 inches	0°,10°,15°,30°,45°
18 inches	30°,45°

