

Scan QR code to
access product
information on your
mobile device.

We reserve the right to change or revise specifications and product design in connection with any feature of our products. Such changes do not entitle the buyer to corresponding changes, improvements, additions or replacements for equipment previously sold or shipped.

Item	Part #	Description	Wiring Item #	Item	Part #	Description	Wiring Item #
FAN ASSEMBLIES				LAMPS AND BALLAST			
4 Ft, 8 Ft & 12 Ft				E.		Ballast, Electronic	(5)
A.	7W Standard Energy Efficient Fan Assembly	(1)		0480130		2 lamps (BA.4481676)	
	0477654	Fan Motor, Evaporator		0480131		3 lamps (BA.4481654)	
		(MO.4410545)		0480132		4 lamps (BA.4481677)	
	0142780	Fan Blade (FB. 0142780)		F.		Fluorescent Lamp	(6)
						<i>Replace with like fixtures</i>	
THERMOSTATS				LED FIXTURES AND POWER SUPPLY			
B.	0411744	Standard Non-adjustable Defrost Thermostat	(2)	G.	0501213	Power Supply (EP.4481861)	(7)
		(CT. 0411744)		H.		LED Canopy Fixture	(8)
						<i>Replace with like fixtures</i>	
C.		Optional Adjustable Refrigeration Thermostat	(3)	I.		LED Shelf Fixture	(9)
						<i>Replace with like fixtures</i>	
HEATERS							
D.		Canopy Anti-Sweat Heater	(4)				
	0512499	4 ft (HE.4851174)					
	0512501	8 ft (HE.4851176)					
	0512503	12 ft (HE.4851178)					

Data sheet-Excel-C2X-XLGE

Note: Revision N: April 2017. Updated LED energy values. Other changes marked with a bar, circle or underline.

Engineering Plan Views

PHYSICAL DATA	
Merchandiser Drip Pipe (in.)	1 1/4
Merchandiser Liquid Line (in.)	3/8
Merchandiser Suction Line (in.)	7/8

Dairy/Delicatessen Precut & Packaged Produce

Dimensions shown as inches and (mm).

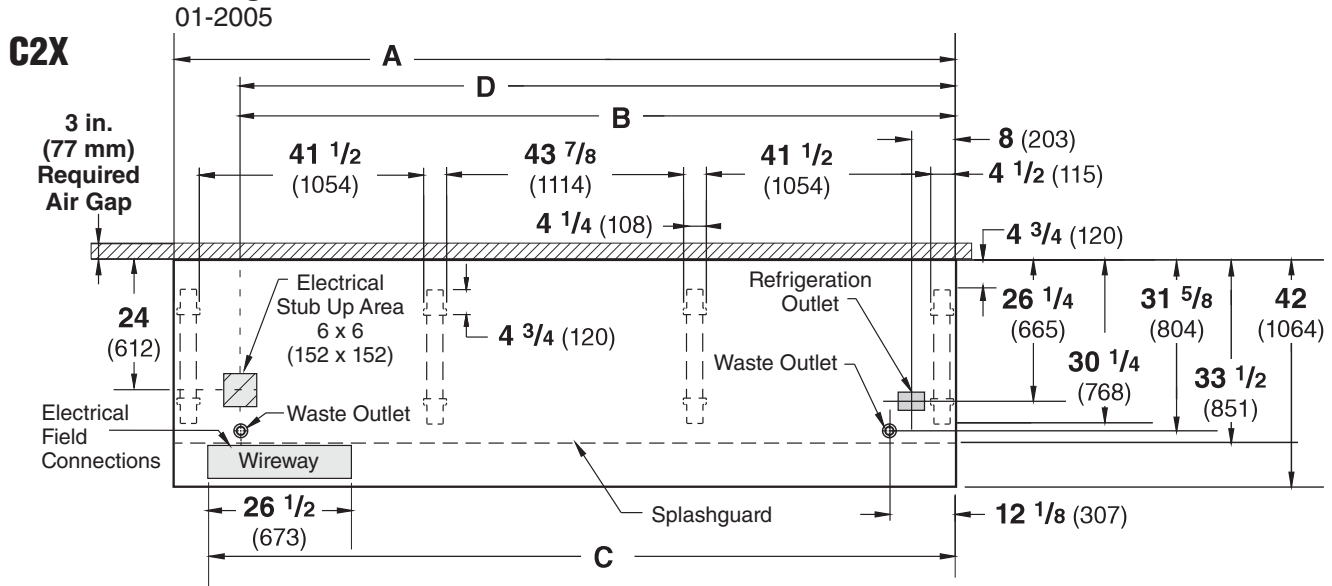

NOTE: Case-to-Case Electrical Connections are made IN FRONT OF SPLASHGUARD.

FRONT

	4 ft	8 ft	12 ft
General			
(A) Case Length (<i>without ends or partitions</i>) (Each end and insulated partition adds 1 1/2 in. (38 mm) to case line up.) Maximum O/S dimension of case back to front (includes bumper)	48 3/8 (1229)	96 3/8 (2448)	144 1/2 (3670)
Back of case to front of splashguard	42 (1064)	42 (1064)	42 (1064)
Back of case to O/S edge of front leg	33 1/2 (851)	33 1/2 (851)	33 1/2 (851)
Distance between edges of external legs and center legs	NA	41 1/2 (1054)	41 1/2 (1054)
Distance between edges of center legs	NA	NA	43 7/8 (1114)
Distance between front legs and splashguard	2 3/4 (70)	2 3/4 (70)	2 3/4 (70)
Electrical Service (<i>Electrical Field Wiring connection point</i>)			
(B) RH End of case to center of stub up area Back of case to center of stub up area Length of electrical wireway	36 1/4 (921) 24 (612) 26 1/2 (673)	84 1/4 (2140) 24 (612) 26 1/2 (673)	132 3/8 (3363) 24 (612) 26 1/2 (673)
(C) RH End of case to LH end of wireway	42 1/8 (1070)	90 1/8 (2289)	138 1/4 (3511)
Waste Outlets (<i>One each end</i>)			
(D) RH End of case to the center of LH waste outlet RH End of case to the center of RH waste outlet Back O/S of case to center of waste outlets Schedule 40 PVC drip pipe	36 1/4 (921) 12 1/8 (307) 31 5/8 (804) 1 1/4 (32)	84 1/4 (2140) 12 1/8 (307) 31 5/8 (804) 1 1/4 (32)	132 3/8 (3363) 12 1/8 (307) 31 5/8 (804) 1 1/4 (32)
Refrigeration Outlet			
Back of case to center of refrigeration outlet RH end of case to center of refrigeration outlet	26 1/4 (665) 8 (203)	26 1/4 (665) 8 (203)	26 1/4 (665) 8 (203)

Multi-deck, 4 Display Levels, Low Front with Glass, 55 In. Back



Hussmann refrigerated merchandisers configured for sale for use in the United States meet or surpass the requirements of the DOE 2017 energy efficiency standards.

Dimensions shown as inches and (mm).

C2X-XLGE

See Page 10 for shelf arrangement.

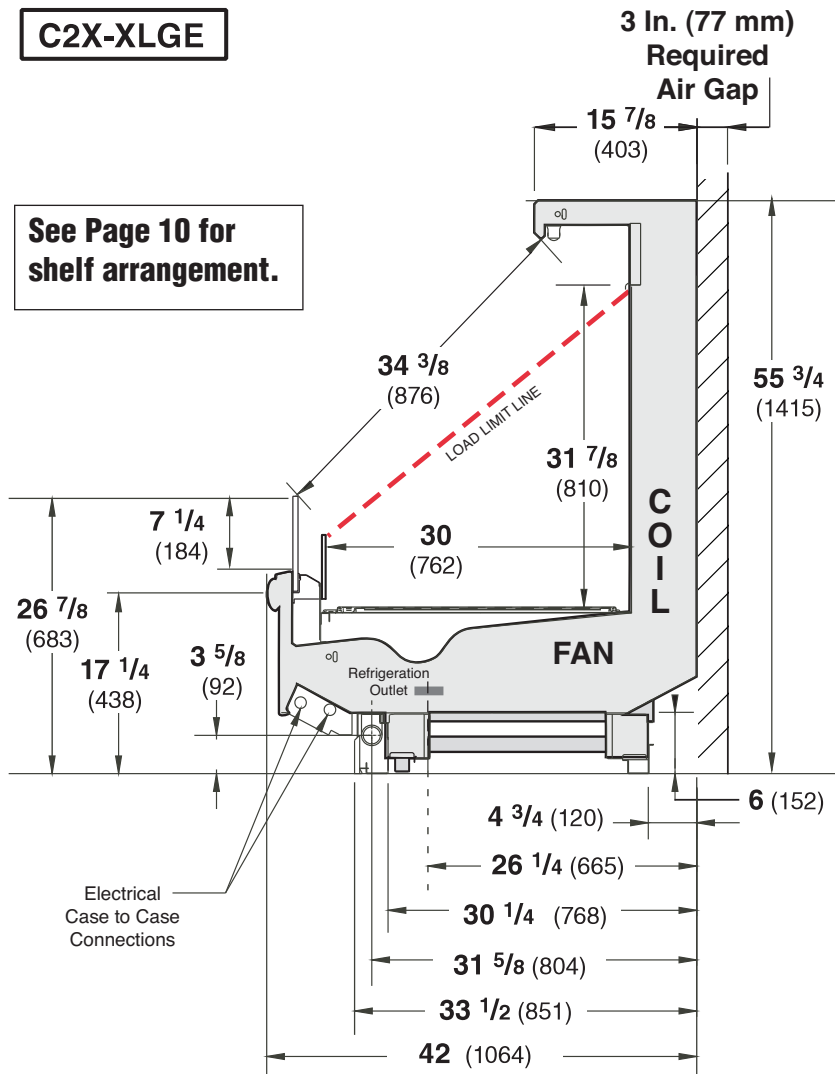

NSF Certification

This merchandiser model is manufactured to meet NSF/ANSI (National Sanitation Foundation) Standard #7 requirements for construction, materials & cleanability.

Estimated Charge **	C2X-LGE	
4 ft	1.2	19 oz 0.5 kg
8 ft	2.3	37 oz 1.0 kg
12 ft	3.3	53 oz 1.5 kg

**This is an average for all refrigerant types. Actual refrigerant charge may vary by approximately half a pound (8 oz/0.2 kg).

Excel C2X-XLGE
Dairy/Delicatessen
Precut & Packaged Produce

REFRIGERATION DATA

Note: This data is based on store temperature and humidity that does not exceed 75°F and 55% R.H.

	C2X-XLGE§
Discharge Air °F	29
Evaporator °F	21
Unit Sizing °F	19

§ Average evaporator temperature shown. Use dew point for high glide refrigerants for unit sizing. Care should be taken to use the dew point in PT tables for measuring and adjusting superheat. Adjust evaporator pressure as needed to maintain discharge air temperature shown.

Btu/hr/ft — Unlit Shelves ‡

C2X-XLGE	Parallel	Conventional
UNLIT	1059	1114

‡Add 10 Btu/hr/ft per shelf row for LED fixtures.
Add 20 Btu/hr/ft per shelf row for fluorescent lamps.

DEFROST DATA

	C2X-XLGE
Frequency (hr)	6
Defrost Water (lb/ft/day)	7
(±15% based on case configuration and product loading.)	
OFFTIME	C2X-XLGE
Temp Term °F	48°F
Failsafe Minutes	30

ELECTRIC OR GAS Not Recommended

Standard Defrost Thermostat

Close on rise: close 48°F – open 33°F

CONVENTIONAL CONTROLS

Low Pressure Backup Control

	C2X-XLGE
CI/CO*	14°F / 4°F

Indoor Unit Only, Pressure Defrost

Termination* 48°F

*Use a Temperature Pressure Chart to determine PSIG conversions.

Excel C2X-XLGE
Dairy/Delicatessen
Precut & Packaged Produce

Electrical Data

	4 ft	8 ft	12 ft			
Number of Fans—7W	1	2	3			
	Amperes			Watts		
	4 ft	8 ft	12 ft	4 ft	8 ft	12 ft
Evaporator Fan						
120V 50/60Hz Standard Energy Efficient	0.19	0.38	0.57	14	28	42
230V 50/60Hz Standard Energy Efficient	0.10	0.20	0.30	14	28	42
230V 60Hz Export	0.25	0.50	0.75	39	78	117
230V 50Hz Export	0.28	0.56	0.84	42	84	126
Minimum Circuit Ampacity †						
120V 50/60Hz Standard Energy Efficient	0.39	0.58	0.77			
230V 50/60Hz Standard Energy Efficient	0.30	0.40	0.50			
230V 60Hz Export	0.45	0.70	0.95			
230V 50Hz Export	0.48	0.76	1.04			
Maximum Over Current Protection 120V	20	20	20			
Maximum Over Current Protection 230V	15	15	15			
Anti-sweat Heaters						
120V 50/60Hz Standard	0.10	0.20	0.30	12	24	36
Standard Lighting (T-8 Fluorescent)						
1 Row Canopy	0.26	0.51	0.77	30	59	85
ONLY LIGHTING CONFIGURATIONS THAT ARE COMPLIANT WITH THE U.S. DEPT. OF ENERGY (DOE) 2017 REGULATION ARE AVAILABLE FOR SALE FOR USE IN THE U.S.A.						
Optional Lighting (T-8 Fluorescent)						
Additional 1 Row Canopy	0.26	0.51	0.77	30	59	85
1 Row Rail Light	NA — Glass front does not accept rail light					
3 Rows of Shelves	0.77	1.53	2.31	59	177	255
EcoShine II Canopy						
1 Row Canopy — EcoShine II	0.16	0.32	0.48	19.3	38.6	58.0
1 Row Canopy — EcoShine II HO	0.22	0.44	0.66	26.5	53.0	79.4
EcoShine II Shelf						
2 Rows of Shelves	0.16	0.33	0.49	19.8	39.5	59.3
3 Rows of Shelves	0.25	0.49	0.74	29.7	59.3	89.0

120V Fluorescent Lighting Circuit Total = Standard Lighting + Total Optional Lighting + Optional Shelf Lighting

120V LED Lighting Circuit Total = Canopy Lighting + Shelf Lighting

230V Lighting Circuit Total = Multiply 120V Lighting Circuit Total by 0.52

† MCA does not include Canopy A/S Heaters because heaters are wired separately from fans.

Please note: some combinations of fluorescent lights on this case model may not be compliant with DOE 2017 and may not be available to order in the US and Canada. More lighting options are available with LED lights. The Hussmann Product Configurator will not allow lighting options that do not comply with the DOE 2017 standards.

Product Data

<i>Recommended Usable Cube</i> ¹ (Cu Ft/Ft)	3.61 ft ³ /ft (0.34 m ³ /m)
<i>AHRI Total Display Area</i> ² (Sq Ft/Ft)	3.36 ft ² /ft (1.02 m ² /m)
<i>Shelf Area</i> ³ (Sq Ft/Ft)	6.36 ft ² /ft (1.94 m ² /m)

- ¹ AHRI Refrigerated Volume less shelving and other unusable space: Refrigerated Volume/Unit of Length, ft³/ft [m³/m]
- ² Computed using AHRI 1200 standard methodology: Total Display Area, ft² [m²]/Unit of Length, ft [m]
- ³ Shelf surface area is composed of bottom deck plus standard shelf complement, as shown in the Hussmann **Product Reference Guide**. The standard shelf complement for this model is (1) row of 12-inch shelf, (1) row of 16-inch shelf and (1) row of 18-in shelf.

ESTIMATED SHIPPING WEIGHT ⁴				
Case	<i>4 ft</i>	<i>8 ft</i>	<i>12 ft</i>	Solid End
lb (kg)				<i>(each)</i>
	600 (272)	1000 (454)	1200 (544)	75 (34)

⁴ Actual weights will vary according to optional kits included.

Fan Wiring Offtime Defrost

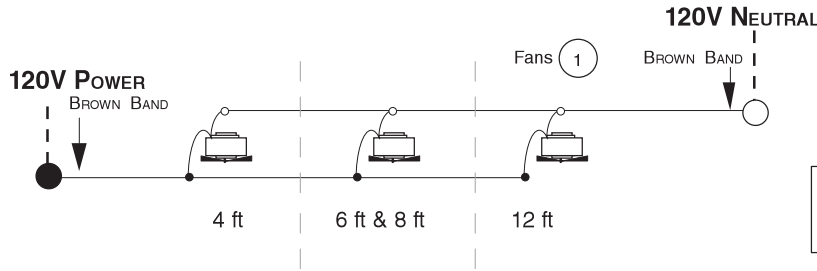

1, 2 & 3 Fans

- 4 ft — 1 Fan
- 6 ft — 2 Fans
- 8 ft — 2 Fans
- 12 ft — 3 Fans

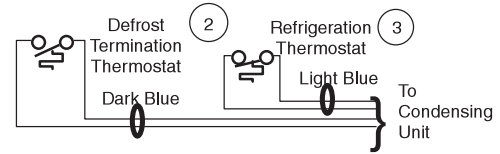

Canopy Fluorescent Light Circuits

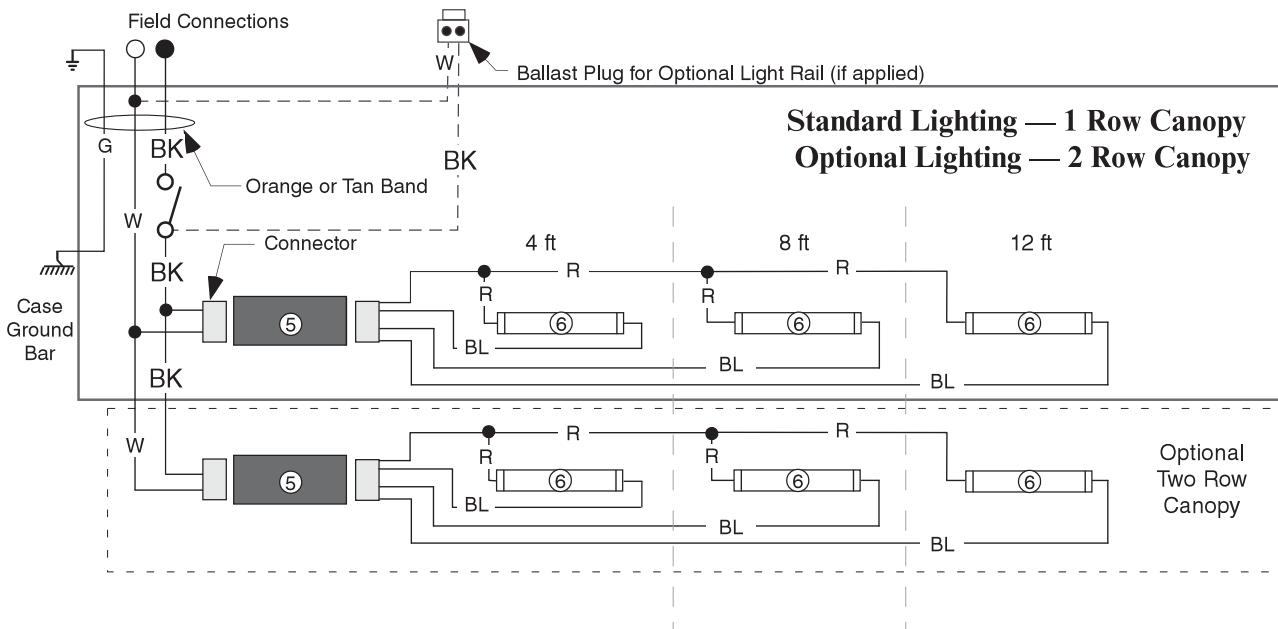

WARNING

All components must have mechanical ground, and the merchandiser must be grounded.

CIRCLED NUMBERS = PARTS LIST ITEM NUMBERS

R = Red Y = Yellow G = Green BL = Blue BK = Black W = White

● = 120V POWER ○ = 120V NEUTRAL ⊥ = FIELD GROUND $\overline{\text{mm}}$ = CASE GROUND

Canopy Anti-Sweat Heater

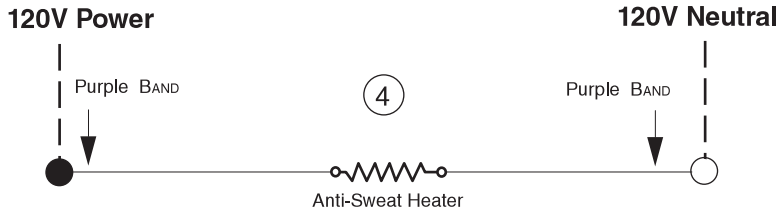

Optional Shelf Lighting Fluorescent Fixtures

Optional Shelf Harness and Light Circuits for Three Rows of Shelves

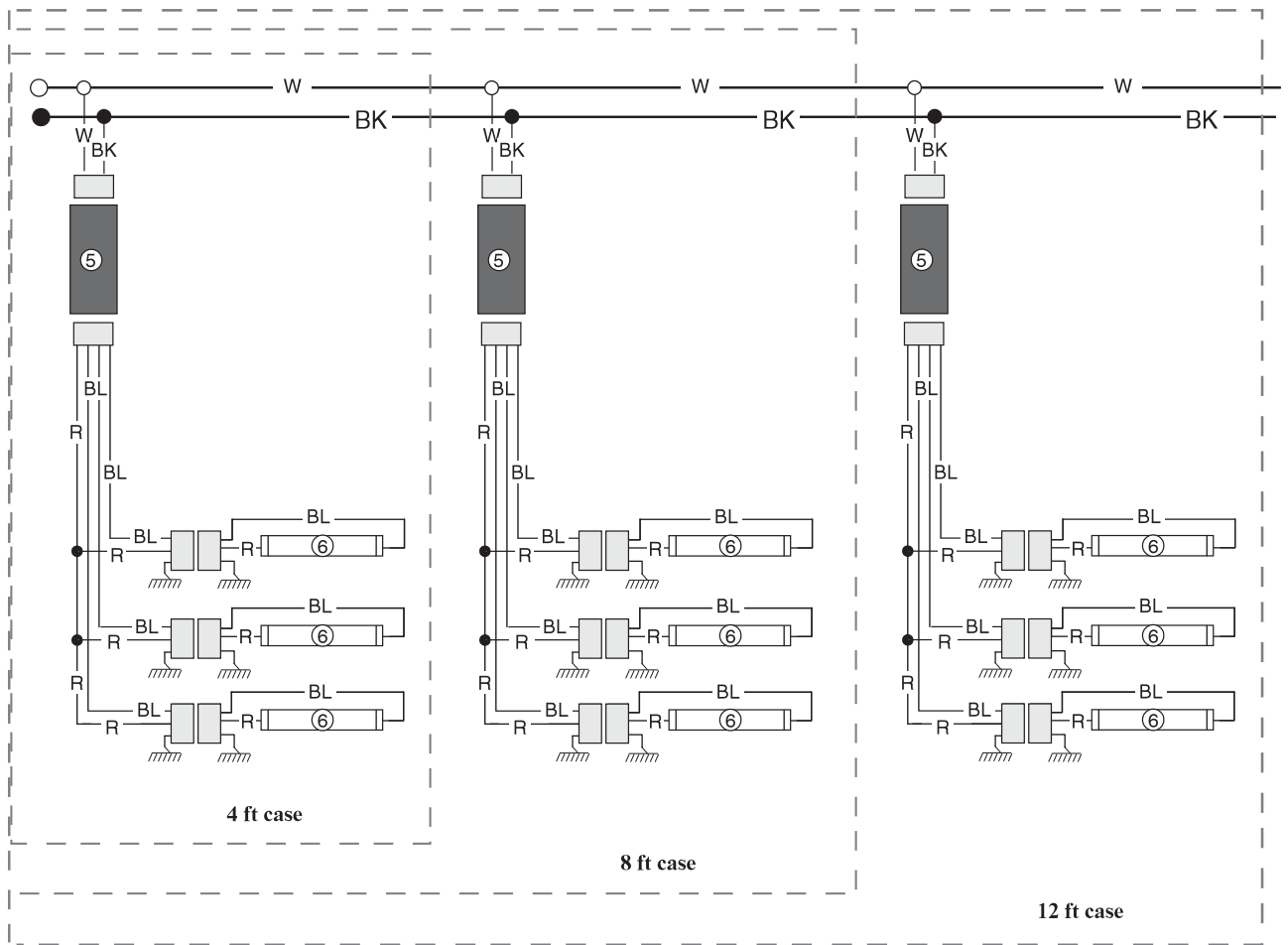

WARNING

All components must have mechanical ground, and the merchandiser must be grounded.

CIRCLED NUMBERS = PARTS LIST ITEM NUMBERS

R = Red Y = Yellow G = Green BL = Blue BK = Black W = White

● = 120V POWER ○ = 120V NEUTRAL ⚡ = FIELD GROUND ≡ = CASE GROUND

Optional Shelf Lighting LED Fixtures

Optional Shelf Harness and LED Light Circuits for 2 or 3 Rows of Shelves

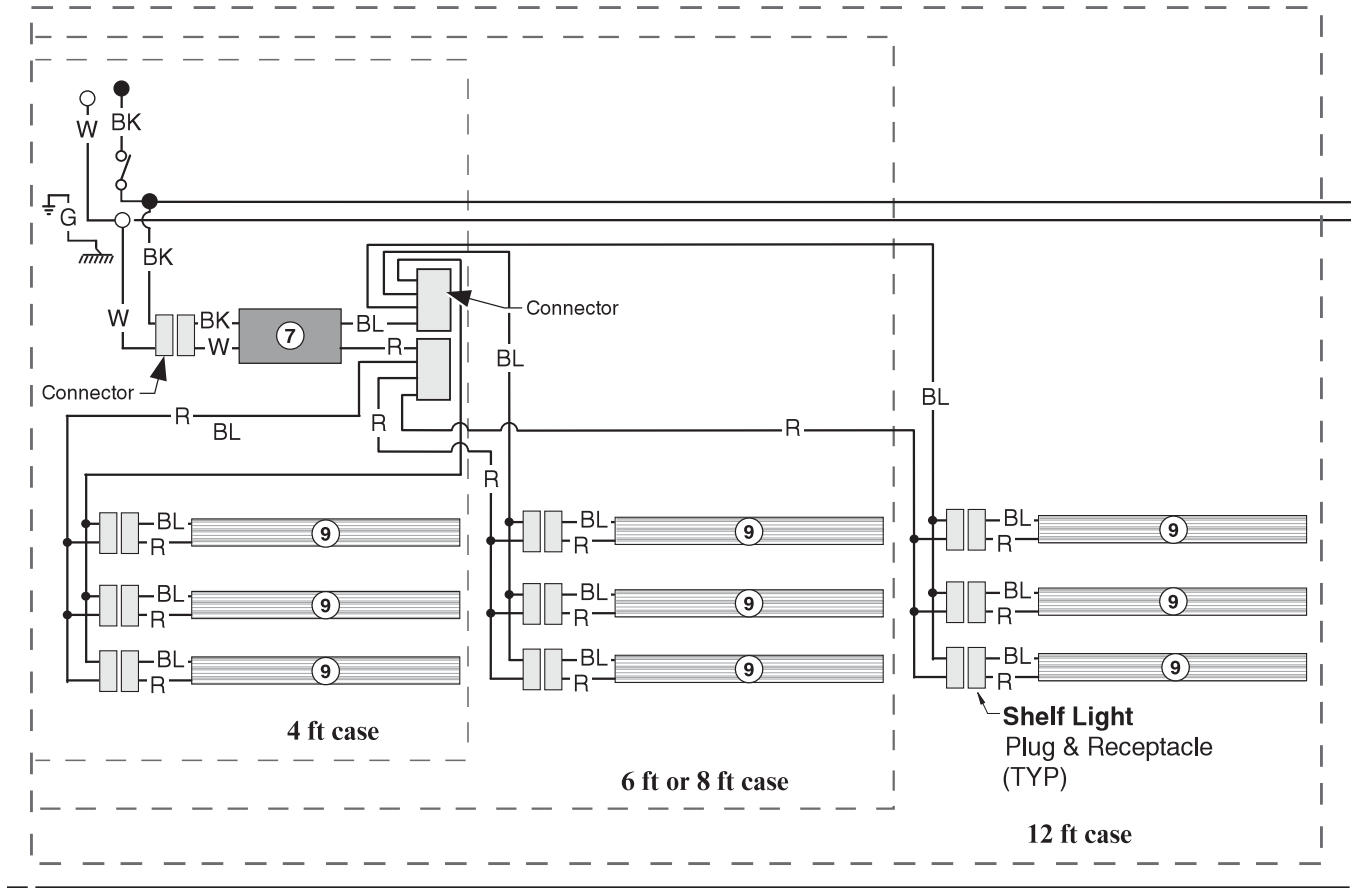

WARNING

All components must have mechanical ground, and the merchandiser must be grounded.

CIRCLED NUMBERS = PARTS LIST ITEM NUMBERS

R = Red G = Green BL = Blue BK = Black W = White

● = 80V POWER ○ = 80V NEUTRAL ⚡ = FIELD GROUND ⏚ = CASE GROUND

Excel C2X-XLGE

Dairy/Delicatessen

Precut & Packaged Produce

SHELF CONFIGURATION

This merchandiser is designed for two or three shelves.

The depth of the shelf used in the top eight (8) shelf hole locations is critical to case performance.

If a shelf is placed in one of the top eight (8) locations it must comply with the angle/depth requirements listed below.

Shelf Angle	Maximum Shelf Depth
0 °	12 in.
15 °	14 in. or less
30 °	18 in. or less
45 °	18 in. or less

NOTE: Shelves placed in the lower positions may be up to 18 in. deep when positioned at a 0 ° angle.

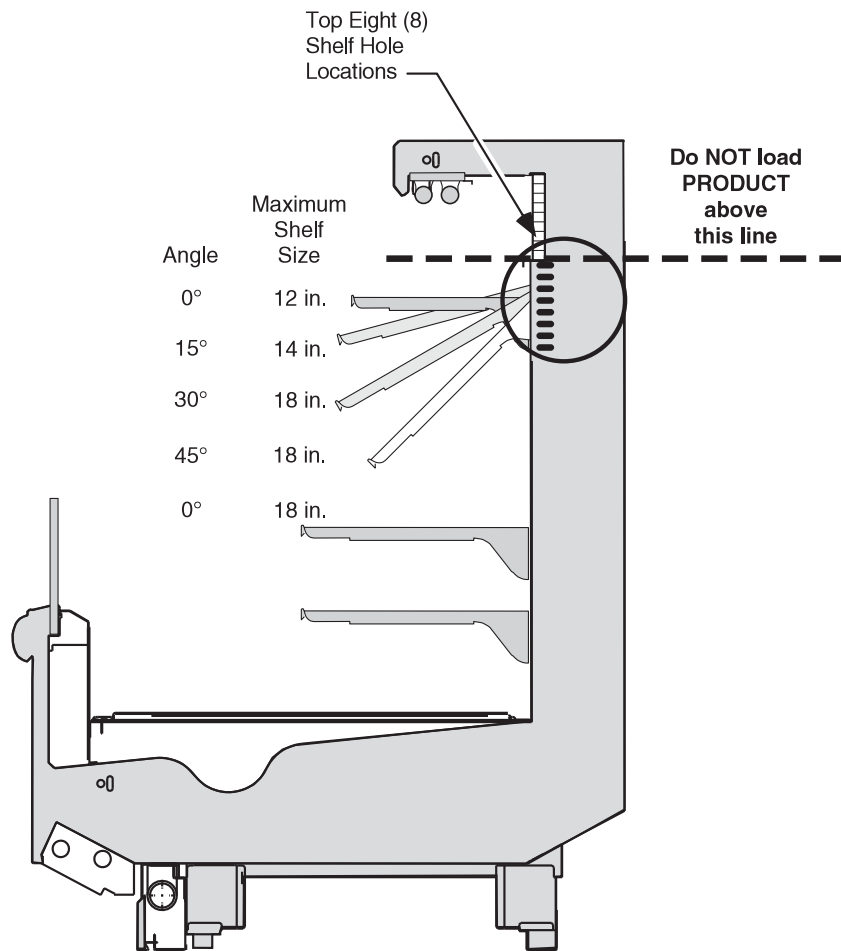

Excel C2X-XLGE
Dairy/Delicatessen
Precut & Packaged Produce

The ballast for the canopy and shelf lamps is located behind the canopy on the left-hand end (when facing case) of the merchandiser.

To access the ballast:

1. Remove screws at bottom edge of canopy and rear of light channel.
2. Lower light channel which will pivot on hinge.
3. Service or replace ballasts as required.
4. Reassemble items as they were originally installed.

NOTE: Rail lamp ballast is located in the electrical raceway.

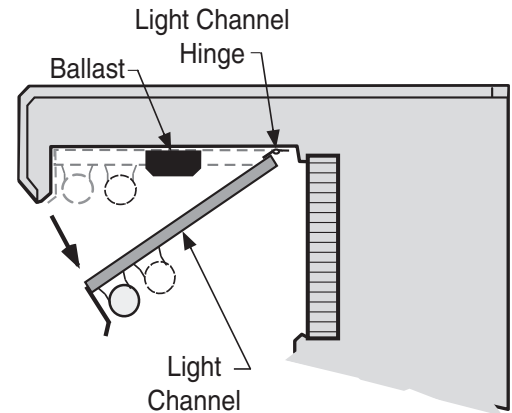
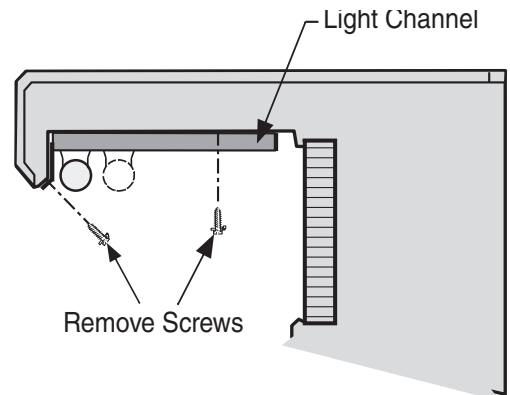

CANOPY ANTI-SWEAT HEATER

The canopy anti-sweat heater location is shown below. Connections are in the electrical wireway.

