

**OPERATING AND MAINTENANCE MANUAL FOR
COMMERCIAL HORIZONTAL CEILING-HUNG
ELECTRIC WATER HEATER**

HubbellTM
ELECTRIC HEATER COMPANY

BASE MODELS “ HE and HSE ”

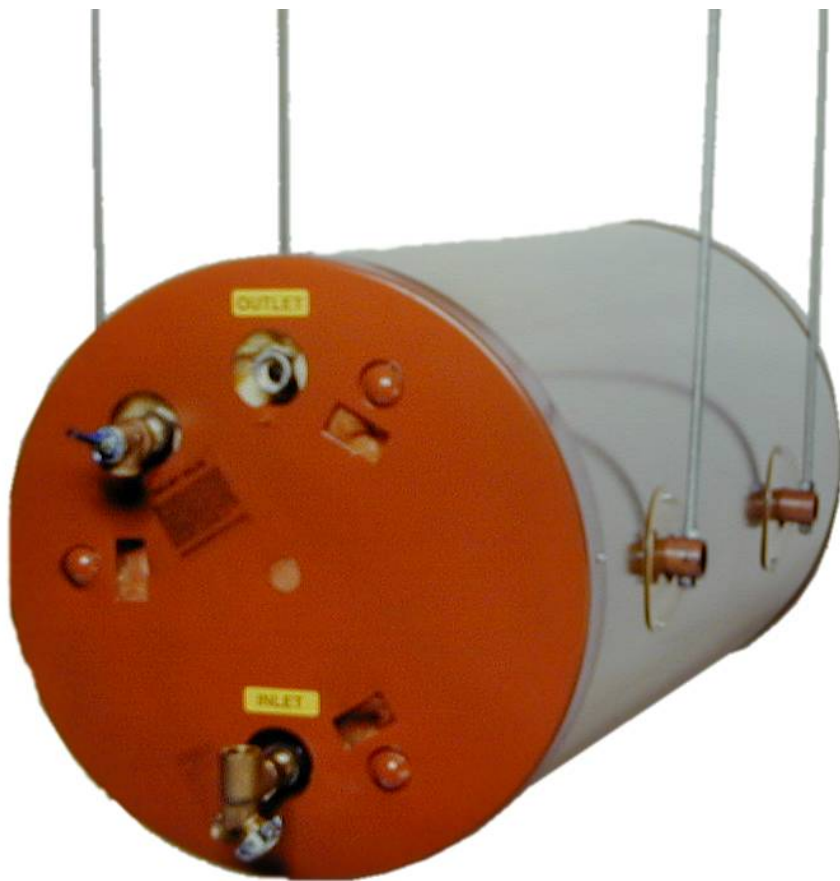

**HUBBELL
ELECTRIC HEATER COMPANY
P.O. BOX 288
STRATFORD, CT 06615**

PHONE: (203) 378-2659

FAX: (203) 378-3593

INTERNET: <http://www.hubbellheaters.com/>

-- IMPORTANT --

Always reference the full model number and serial number when calling the factory.

WARNING / CAUTION

1. Tank is to be completely filled with water and all air is to be vented before energizing.
2. Due to the rigors of transportation, all connections should be checked for tightness before heater is placed in operation.
3. Safety relief valve must be installed in tapping provided.
4. The refractory material used in heating elements may absorb some moisture during transit, periods of storage, or when subjected to a humid environment. This moisture absorption results in a cold insulation resistance of less than one (1) megohms. If this heater has been subjected to the above condition, each heating element must be checked for insulation resistance before energizing. A low megohm condition can be corrected by removing the terminal hardware and baking the element in an oven at 300°F -500°F for several hours or until the proper megohm reading is obtained.
5. **KEEP AWAY FROM LIVE ELECTRICAL CIRCUITS.**
Do not perform any maintenance, make any adjustments, or replace any components inside the control panel with the high voltage power supply turned on. Under certain circumstances, dangerous potentials may exist even when the power supply is off. To avoid casualties, always turn the power supply safety switch to off, turn the charge or ground the circuit before performing any maintenance or adjustment procedure.
6. The unit is designed to operate at pressure not more than 150 psi.
7. Generalized instructions and procedures cannot anticipate all situations. For this reason, only qualified installers should perform the installations. A qualified installer is a person who has licensed training and a working knowledge of the applicable codes regulation, tools, equipment, and methods necessary for safe installation of an electric resistance water heater. If questions regarding installation arise, check your local plumbing and electrical inspectors for proper procedures and codes. If you cannot obtain the required information, contact the company.

TABLE OF CONTENTS

SECTION	TITLE	PAGE No.
I	GENERAL DESCRIPTION AND CONSTRUCTION	4
II	INSTALLATION	5
III	SCHEDULED MAINTENANCE AND OPERATION	7
IV	TROUBLESHOOTING	8
V	SERVICING AND REPLACEMENT OF PARTS	9
VI	MISCELANEOUS CHARTS AND FORMULAS	13

OUTLINE DIMENSIONS

Base Models	Storage Capacity (Gallons)	Dimensional Data (Inches)		Dry Weight (LBS)
		Overall Diameter	Overall Length	
HE20 HSE20	20	20	37	135
HE30 HSE30	30	20	45.5	165

Note: Contractor to supply $\frac{3}{8}$ " diameter Tie Rod for hanging installation.

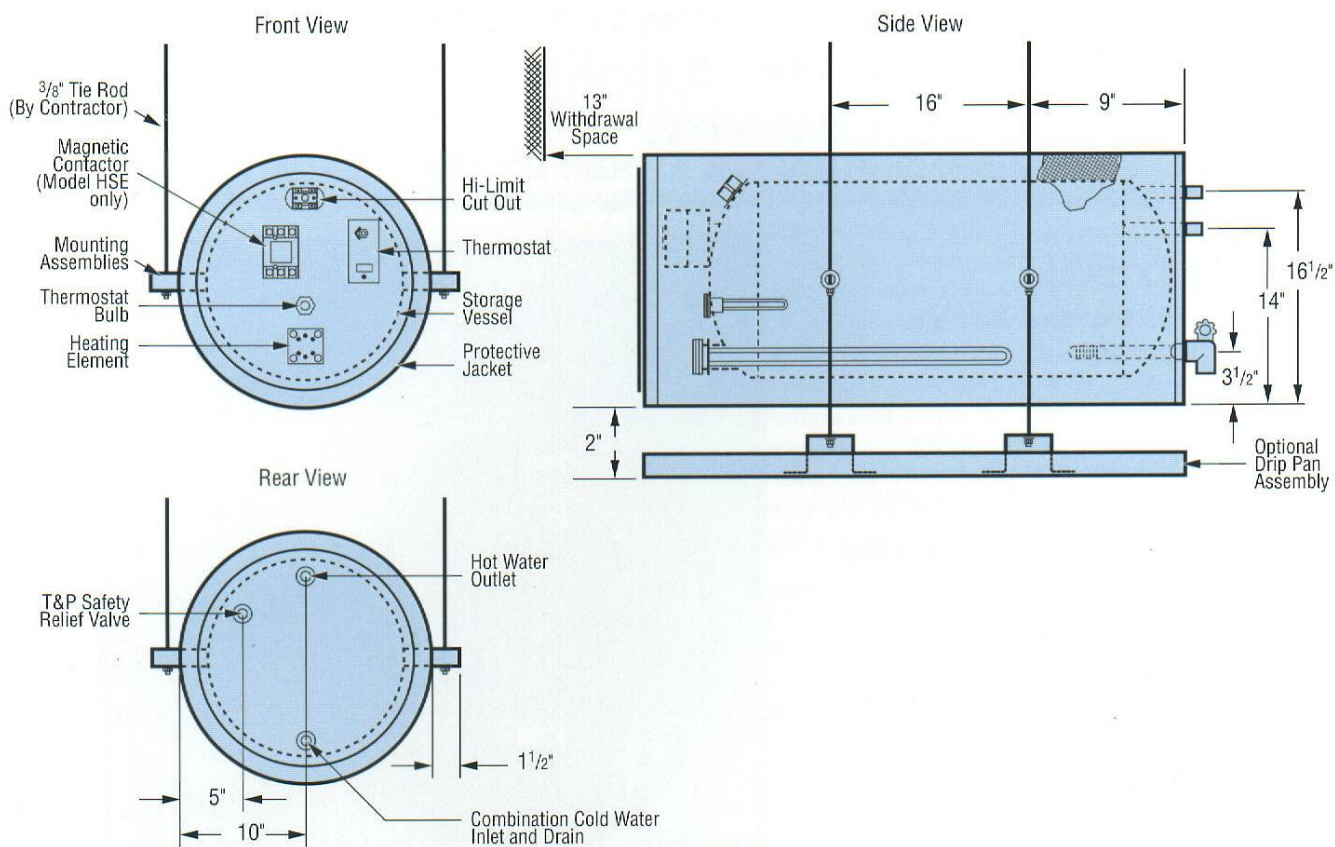

SECTION I - GENERAL DESCRIPTION AND CONSTRUCTION

GENERAL DESCRIPTION

This book describes a packaged electric water heater that is a stationary, self-contained unit. The complete assembly consists of the storage tank, immersion electric heating element(s), thermostat, safety relief valve, safety high temperature cut out, and any other required electrical operating control. Optional equipment may be supplied with your unit. Please consult the product drawing for details specific to your assembly. The unit is factory assembled, insulated, jacketed, wired, tested, and ready for electrical and plumbing service connections.

CONSTRUCTION

TANK

The standard storage tank is constructed of steel and internally lined with specially formulated Hydrastone cement to a 1/2-inch minimum thickness. The tank is designed for a maximum allowable working pressure of 150 psi (300 psi TP).

TANK CONNECTIONS

The heater is supplied with separate cold water and hot water connections. Water entering the cold water inlet is deflected by means of a baffle within the tank. A 3/4-inch FNPT connection is located on the side of the heater for mounting a combination safety temperature and pressure relief valve. An overflow line should be utilized from the relief valve outlet to a floor drain. A 3/4-inch GHT connection is supplied for draining. See drawing for locations and sizes.

CONTROL THERMOSTAT

The water heater is supplied with an immersion thermostatic switch that is installed and wired at the factory. The immersion thermostat can be adjusted through a range of 100° - 190° F and is adjustable with a flat tip screwdriver. An optional low range (30° - 110° F) thermostat may be supplied.



TEMPERATURE HIGH LIMIT SWITCH

As a safety device, a surface mounted high temperature cut-off switch with manual reset, factory set at 190° F is provided. In the event of an over-temperature condition, the thermostat will disengage the power from the unit, (in the HSE model the thermostat will disengage the operating coils in the magnetic contactor). The high limit must be manually reset thereafter to restart the heater.

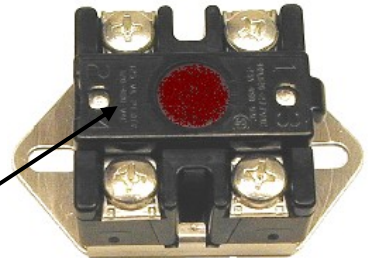

Manual Reset

HEATING ELEMENT

The water heater is supplied with an electric immersion heating element assembly(s), composed of incoloy or copper sheathed elements that are brazed into a brass flange. Each assembly is fastened to a corresponding tank flange using a gasket and four (4) 3/8-16 x 1-inch long hex head steel bolts and nuts. See drawing for voltage and power ratings.



Single Phase Copper Sheathed Element



3-Phase Incoloy Sheathed Element

MAGNETIC CONTACTOR (HSE Models Only)

The magnetic contactor(s) is a heavy-duty resistive load type rated for 100,000 cycles. The contactor supplies power to the heating element(s) based on the resistive load (non-inductive) of the heater only when the thermostatic switch is engaged, thereby pulling in the contacts until the desired temperature is reached. At this point, the contacts will drop out, which in turn disconnects power from the elements.



OUTER SHELL AND INSULATION

The tank is encapsulated in 2-inch thick polyurethane foam insulation. The insulation is protected by a high impact non-corroding colored composite protective jacket.

DRIP PAN (Optional)

A drip pan assembly may be supplied as an option with the unit. It is designed to mount directly beneath the water heater as shown in the sketch on page 4.

SWAY RESISTANT MOUNTS (Optional)

Optional sway resistant mounts may be supplied to further secure the tank from longitudinal movement. Additional 3/8" diameter threaded rods (not supplied) are fastened into additional nuts that are welded to the support mount.

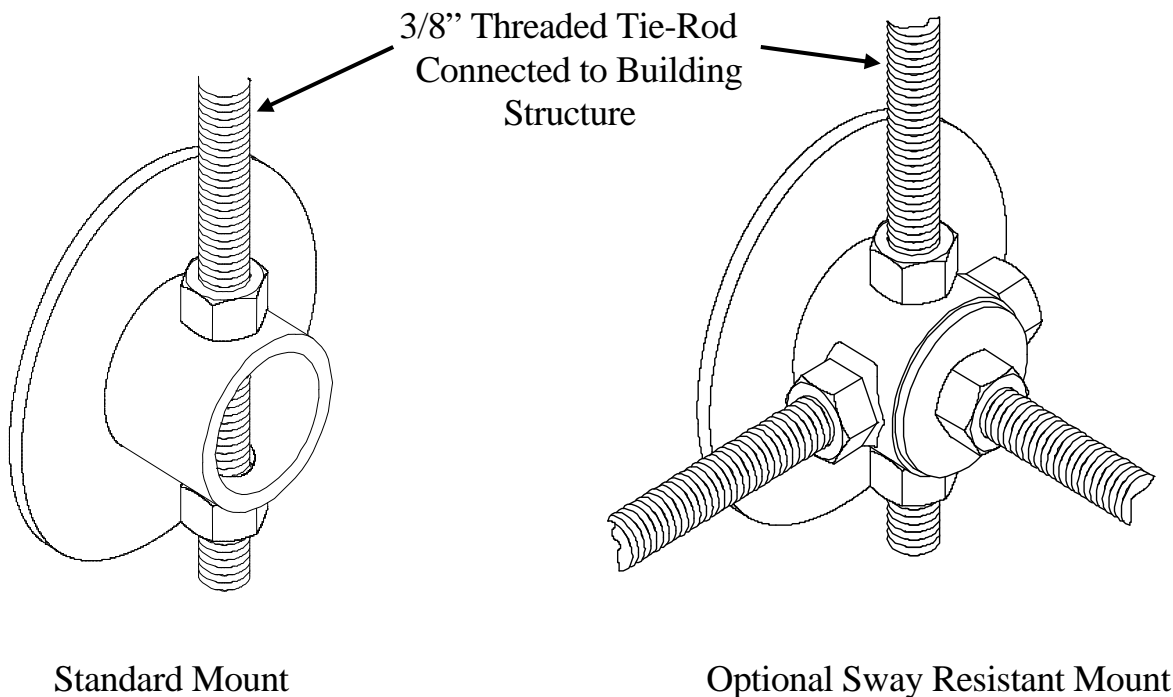

SECTION II – INSTALLATION

WARNING / CAUTION

DO NOT TURN ON THE ELECTRIC POWER SUPPLY to this equipment until heater is completely filled with water and all air has been released. *If the heater is NOT filled with water when the power is turned on, the heating elements will burn out.*

For protection against excessive pressures and temperatures, local codes require the installation of a temperature-and-pressure (T&P) relief valve certified by a nationally recognized laboratory that maintains periodic inspection of production of listed equipment of materials, as meeting the requirements for Relief Valves and Automatic Gas Shutoff for Hot Water Supply Systems. ANSI Z21.22-1971. **THE CUSTOMER IS RESPONSIBLE TO PROTECT PROPERTY AND PERSONNEL FROM HARM WHEN THE VALVE FUNCTIONS.**

All water heaters have a risk of leakage at some unpredictable time. **IT IS THE CUSTOMER'S RESPONSIBILITY TO PROVIDE A CATCH PAN OR OTHER ADEQUATE MEANS, SO THAT THE RESULTANT FLOW OF WATER WILL NOT DAMAGE FURNISHINGS OR PROPERTY.**

WATER HEATER PLACEMENT

1. Locate heater in a dry location nearest to the point of most frequent hot water use
2. Mount tank using 3/8" diameter threaded rod (not supplied) to suitable ceiling supports (not supplied).
3. Install 3/8" diameter threaded rod (not supplied) into the four (4) mounting assemblies on the tank.
4. Install drip pan, if supplied.

5. The water heater should be protected from freezing and waterlines insulated to reduce energy and water waste.
6. Leave a minimum of 13” clearance for element withdrawal, if necessary.
7. Do not install in an area where flammable liquids or combustible vapors are present.

PIPING INSTALLATION

NOTE: The most effective means for preventing deterioration from accelerated corrosion due to galvanic and stray current is the installation of dielectric fittings/unions. The installation of these fittings is the responsibility of the installing contractor.

1. Thread cold water inlet and diffuser assembly into tank. Diffuser slots must be pointing down toward the bottom of the tank.

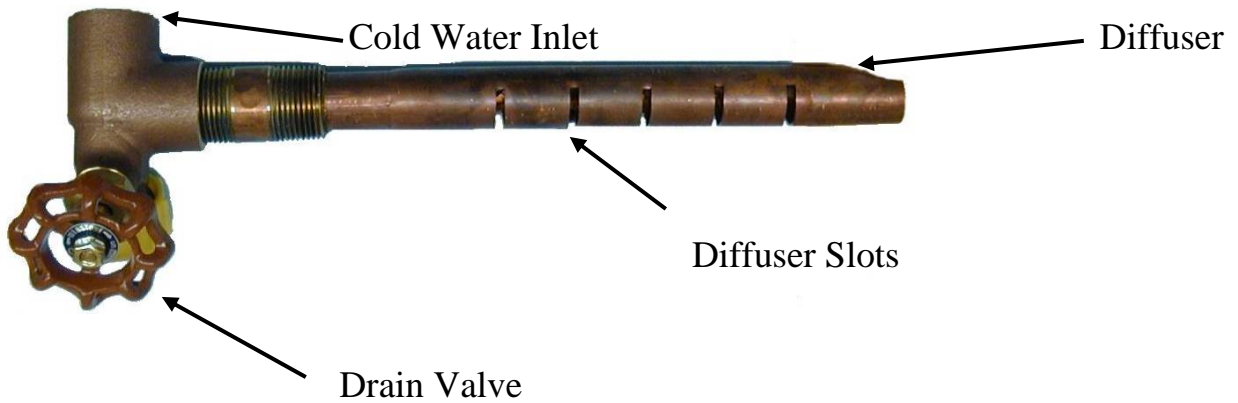

2. Connect the cold water inlet and hot water outlet to the appropriate connections as shown; refer to the drawing for location and sizes.
3. Install in-line vacuum breaker, if supplied.
4. Install in-line pressure and temperature gauge, if supplied.
5. Install the combination temperature and pressure safety relief valve in the tapping provided. Note that this is required by law for safety considerations.

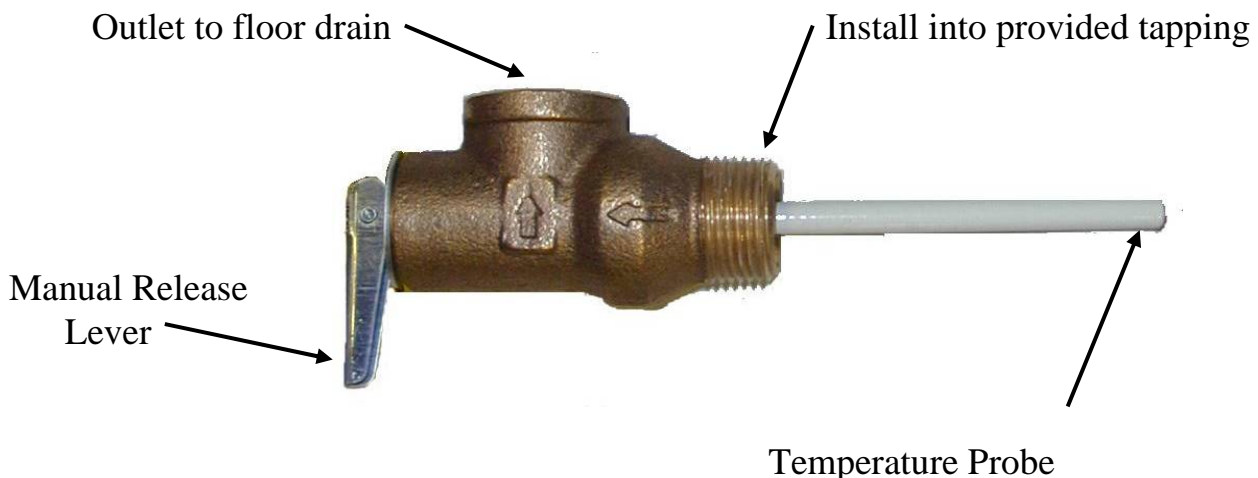

6. Install a relief valve overflow pipe to a nearby floor drain. **CAUTION:** No valve of any type should be installed between the relief valve and tank or in the drain line.

FILLING THE HEATER

1. Completely close the drain valve.
2. Open the highest hot water faucet to allow all air to escape from piping.
3. Open the valve to the cold water inlet and allow the heater and piping system to completely fill, as indicated by a steady flow of water from the open faucet.

ELECTRICAL INSTALLATION

1. Enter electric enclosure with properly sized feeder leads. Single-phase installations require two (2) leads; three phase installations require three (3) leads.
2. Install these power leads onto terminals ‘1’ and ‘3’ of the high temperature cut-off, for single phase installation, or the magnetic contactor for 3-phase installation.
3. Torque screws per torque chart included in Section VI.
4. All other electrical connections are made at the factory; therefore, no other electrical connections are necessary.

FINAL CHECKS

1. Check all connections for tightness.
2. Ensure that all the above steps are completed
3. After the water is heated for the first time, monitor the water temperature as described in Section III, Quarterly Inspection.

SECTION III - SCHEDULED MAINTENANCE AND OPERATION

WARNING / CAUTION

Before performing any maintenance procedure, make certain power supply is OFF and cannot accidentally be turned on.

MAINTENANCE AND OPERATION

The water heater is automatic in its operation. It will maintain a full tank of water at the temperature setting of the thermostat. The water heater should not be turned on without first making sure that the tank is full of water and that all air has been released.

FREEZING

The tank should be fully drained in the event the electricity has been turned off and if there is danger of freezing.

QUARTERLY INSPECTION

1. Monitor thermostat
 - a. Let water heater completely heat to a designated thermostat setting.
 - b. After thermostat satisfies (that is, when the thermostat actually clicks off), draw water from heater.
 - c. Compare water temperature of drawn water to the temperature setting of the thermostat when it satisfies. Normal variation between the two points is approximately $\pm 5^{\circ}\text{F}$.
 - d. If these two readings do not coincide within acceptable tolerances and verification has been made of the accuracy of the temperature-reading gauge, replace the thermostat.
2. Lift test lever on relief valve and let water run through valve for a period of approximately 10 seconds. This will help flush away any sediment that might build up in water passageways.
3. Inspect element flange for leakage as follows:
 - a. Shut off Power Supply.
 - b. Remove element housing cover.
 - c. Visually inspect heating element gasket for evidence of leaks.
 - d. Rub finger around gasket that is between the heating element and tank flange for any evidence of moisture. If moisture is present or a water drip is observed, follow procedure outlined in Section V.
4. Inspect ceiling supports for tightness and/or damage.
5. Check for loose electrical connections. Tighten as necessary.

ANNUAL INSPECTION

1. Flush tank as follows
 - a. Shut off power supply.
 - b. Close valve on hot water outlet piping.
 - c. Open valve on drain piping.
 - d. Cold water inlet line pressure will be strong enough to flush sediment from the bottom of the tank out through the drain. Let water run for 3-4 minutes.
 - e. Close drain valve.
 - f. Open hot water valve.
 - g. Turn power supply ON.

SECTION IV – TROUBLESHOOTING

Symptom	Probable Cause	Corrective Action / Remedy
No hot water	Circuit breaker tripped at source.	Reset circuit breaker.
	High limit switch tripped.	Reset high limit switch.
	Loose wires.	Tighten wires. Torque screws per torque chart included in Section VI.
	Heating element inoperable.	Check heating element operation by clamping an Amprobe around each wire to the element. The ampere reading should agree with the nameplate 'AMP' figure.
	Low line voltage.	Have source electrical system checked by an electrician.
	Faulty thermostat.	Move thermostat dial through full range. A definite 'click' should be heard. If not, replace thermostat.
	Magnetic contactor does not energize.	Replace complete magnetic contactor. Because of the design of this particular contactor, it is more desirable to replace complete control rather than rebuilding coil, contacts and springs, etc.
Water temperature below settings at all times	Faulty thermostat.	Check thermostat adjustment. Monitor thermostat as described in Section III, Quarterly Inspection. Replace if necessary.
	Heating element not working on all phases	Check to see that heating element is working on all phases, by checking the resistance (ohms) value for each element and comparing with the chart included in Section VI.
	Heater improperly sized	Verify heater is properly sized for the flow rate and temperature rise of your system. See formulas included in Section VI. Replace elements with proper size as necessary.
Relief valve discharges continuously	Excessive temperature or pressure in tank	Temperature and pressure relief valves are made to operate if the water temperature exceeds 210°F or water pressure exceeds the pressure rating of the safety relief valve. If trouble is excessive temperature, then thermostat is not shutting off at the right setting and thermostat must be replaced.

SECTION V - SERVICING & REPLACEMENT OF PARTS

WARNING / CAUTION

Before servicing or replacing any part make sure to turn the power supply switch to the OFF position.

SURFACE TEMPERATURE HIGH LIMIT CUT-OFF

1. Disconnect power from unit.
2. Remove access cover.
3. Disconnect the four (4) 14 gauge wires.

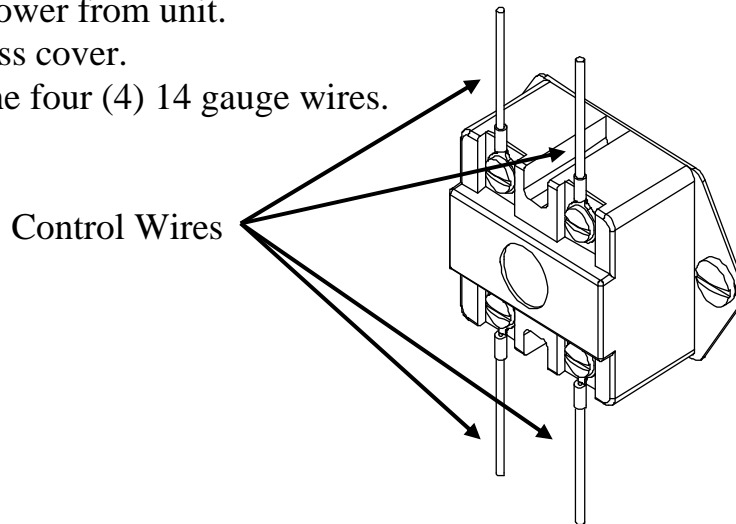

4. Remove the two (2) mounting screws.

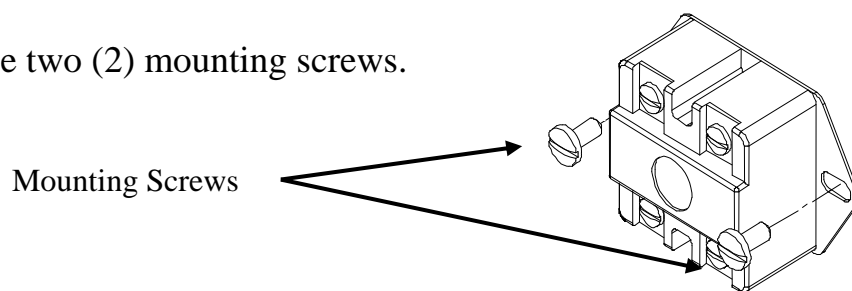

5. Replace control and install new high limit switch by performing above steps in reverse order.

HEATING ELEMENT

1. Disconnect power from unit.
2. Shut off incoming water supply.
3. Attach hose to drain connection.
4. Lift manual release lever on relief valve to let air into system or break union on outgoing water line.
5. Drain water from tank.
6. Disconnect the wires from the heating element terminals.
7. Remove the 3/8-16 nuts.

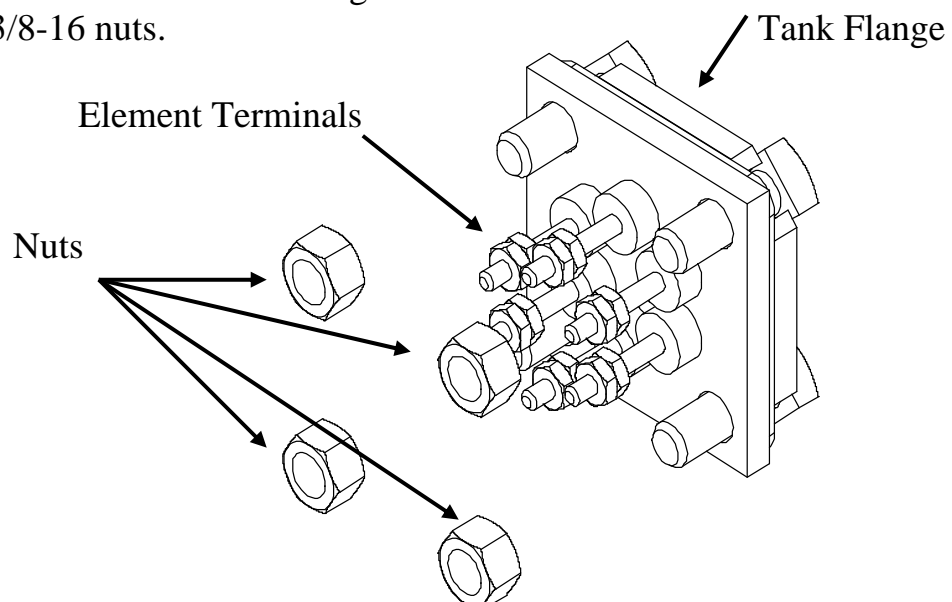

8. Withdraw element assembly and remove gasket.

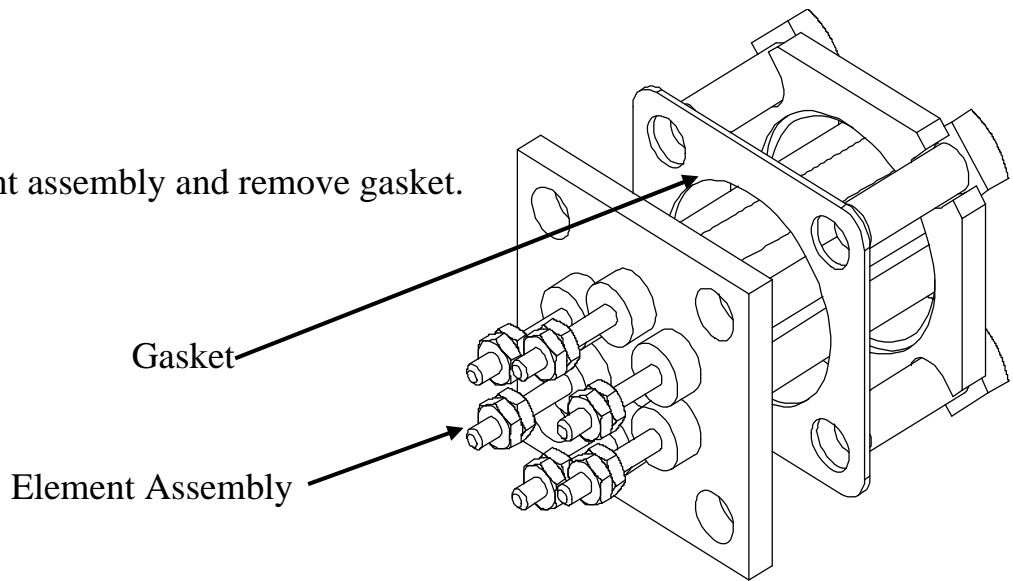

9. Install new gasket and insert new heating element.

10. For 3-phase heaters, rewire the element according to the voltage and phase rating of the unit as shown below. For single phase operations, connect wires to terminals.

11. Fill tank and check around gasket for any leaks.

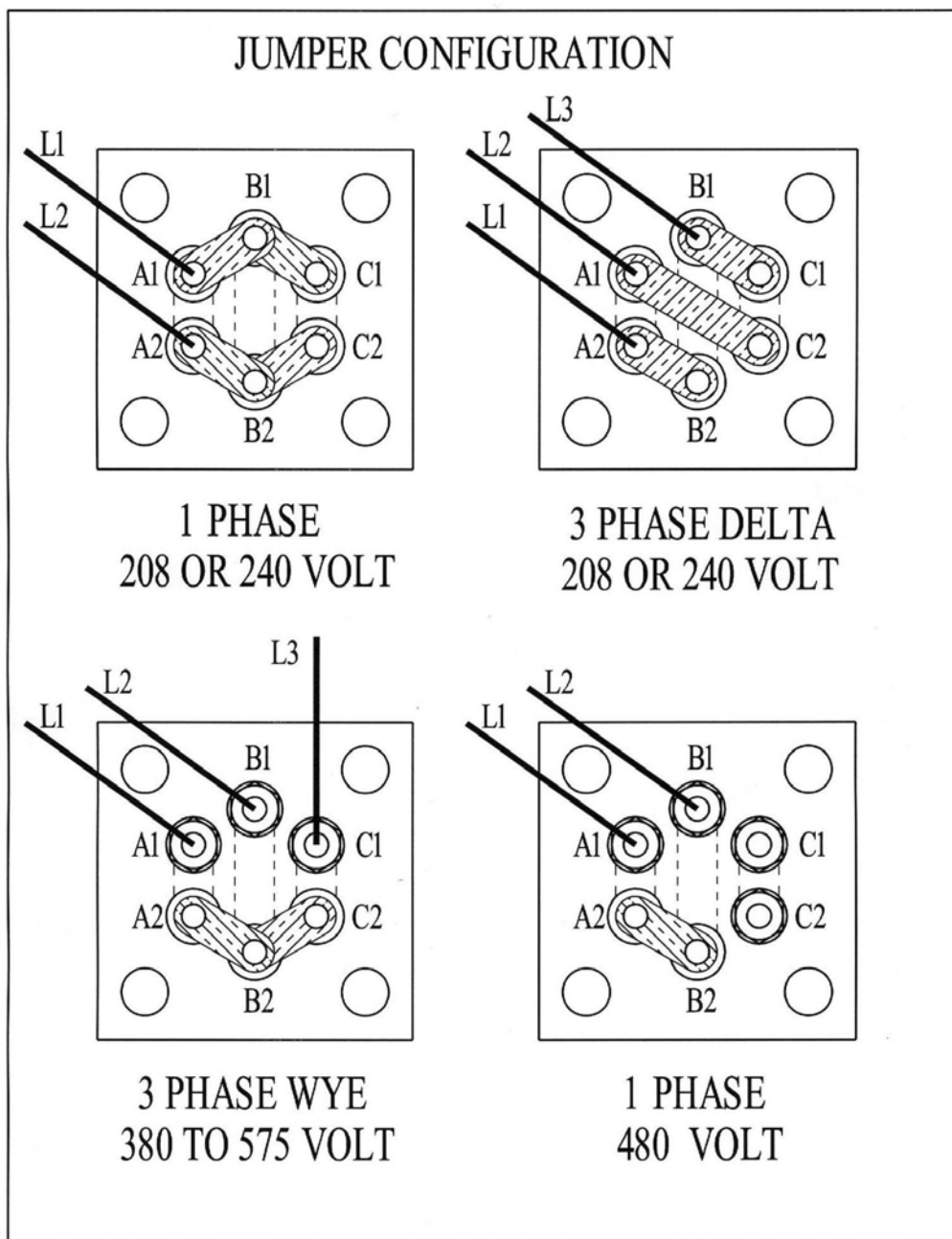

IMMERSION THERMOSTAT

1. Disconnect power from unit.
2. Remove access cover and locate thermostat.
3. Remove high limit cover screw and cover.

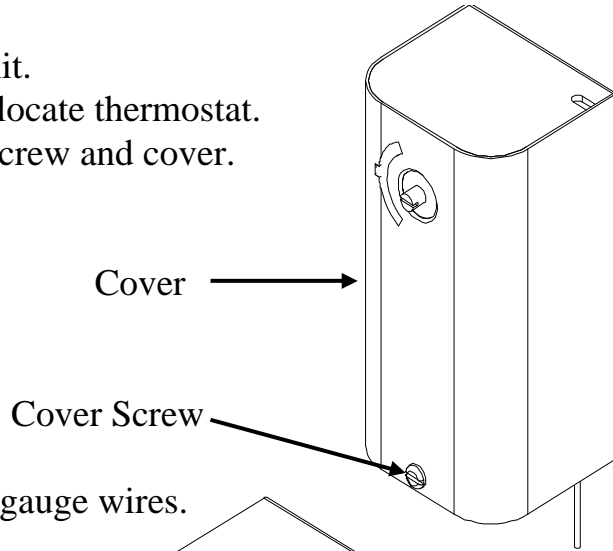

4. Disconnect the two (2) 14 gauge wires.

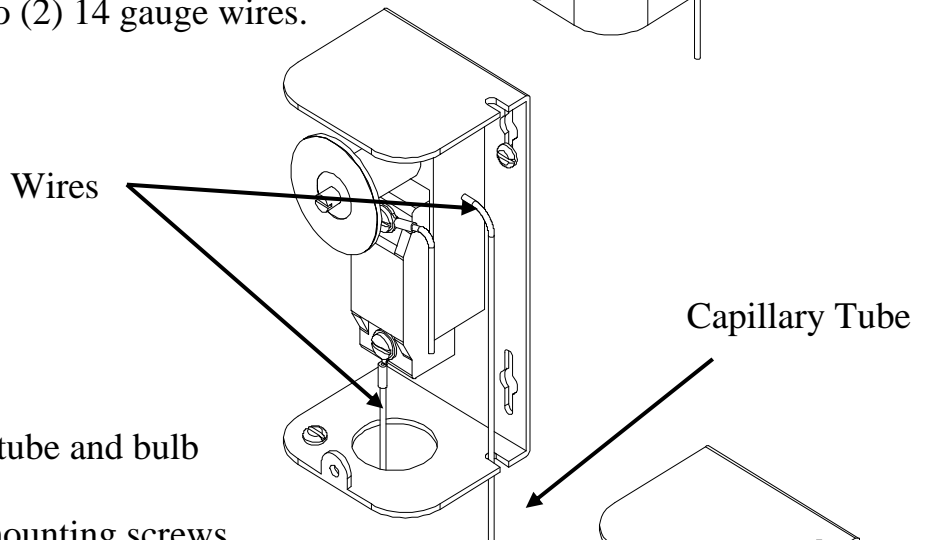

5. Remove capillary tube and bulb from thermowell.
6. Remove two (2) mounting screws.

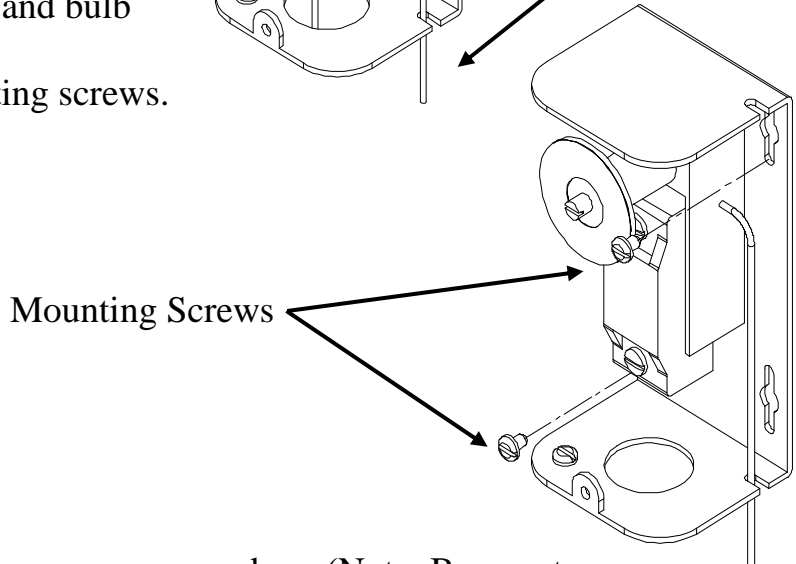

7. Replace thermostat using reverse procedure. (Note: Be sure to place capillary tube into slot in base prior to installing cover.)

MAGNETIC CONTACTOR

1. Disconnect power from unit.
2. Disconnect line and load wires to contactor.
3. Disconnect two (2) 14 gauge control circuit wires.

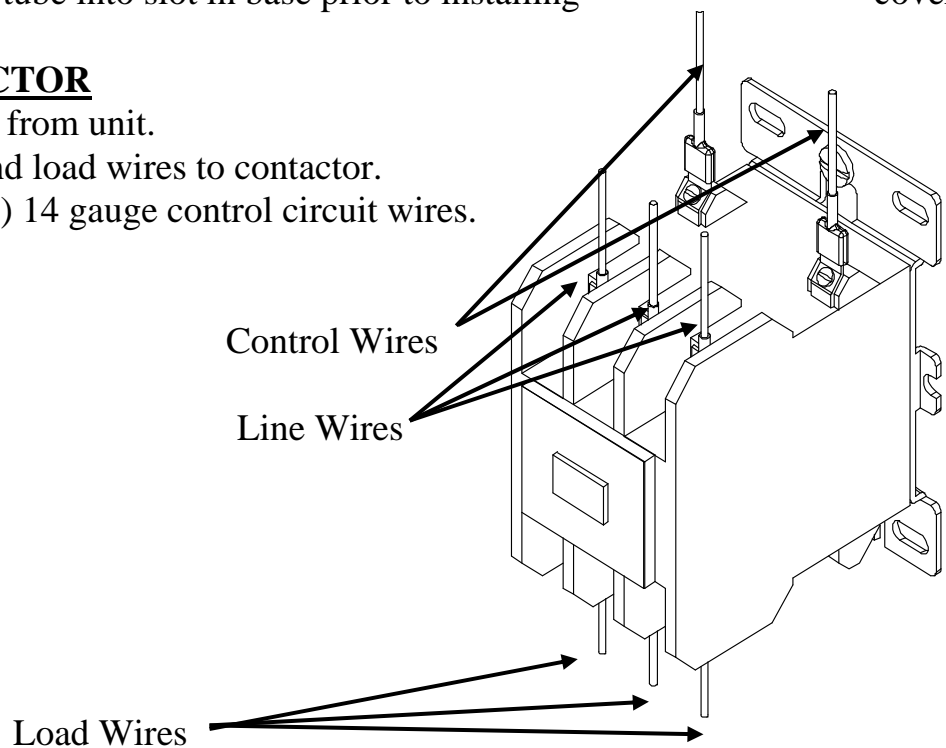

4. Loosen two (2) holding screws and remove contactor.

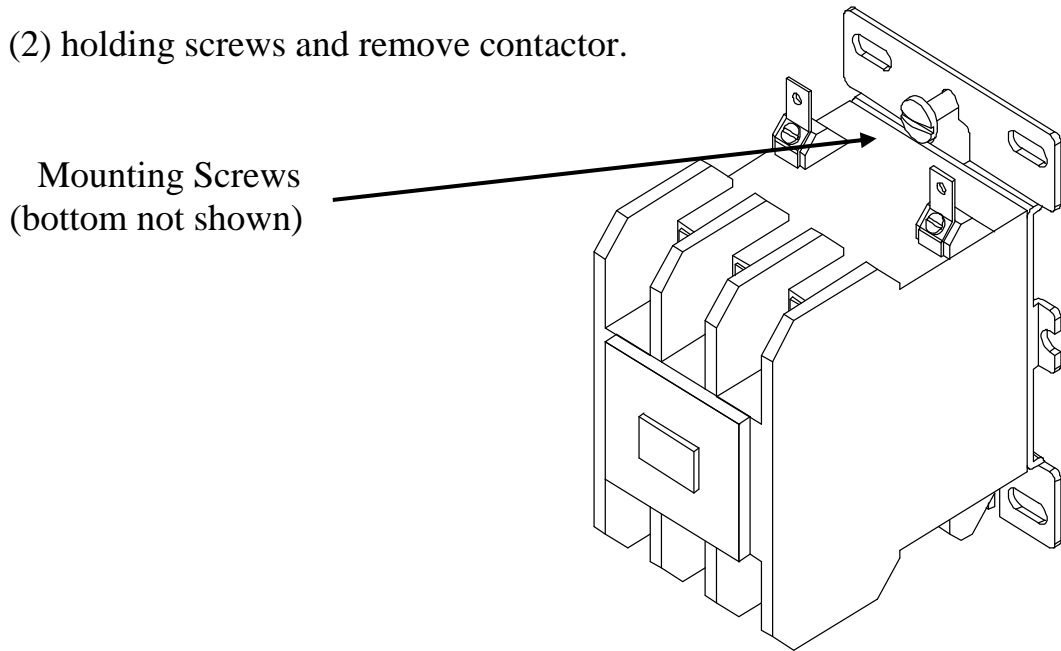

5. Replace with new contactor using reverse procedure.

RELIEF VALVE

1. Disconnect power from unit.
2. Shut off incoming water supply.
3. Lift test lever on relief valve to relieve pressure in tank.
4. Disconnect overflow piping.
5. Unscrew relief valve, remove assembly and replace with new one.
6. Connect overflow piping.
7. Turn on incoming water supply and check for leaks.
8. Turn safety switch to ON position.

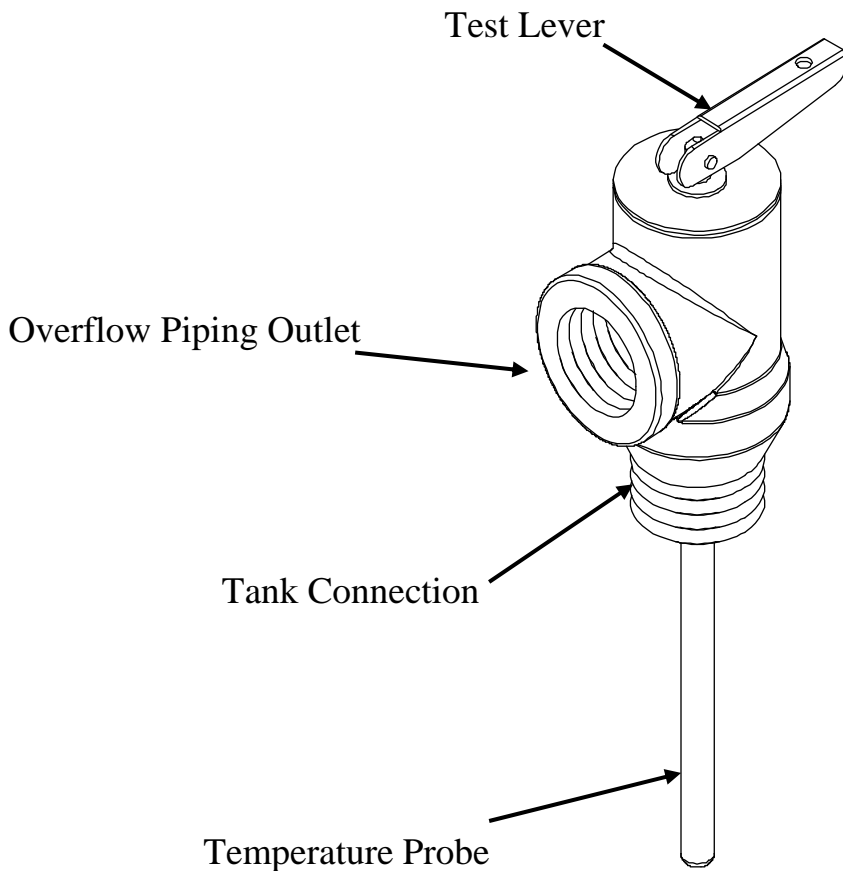

SECTION VI – MISCELLANEOUS CHARTS AND FORMULAS

FORMULAS

RECOVERY

$$\text{GPH} \times \text{_____} \text{ } ^\circ\text{F } \Delta\text{T} \times 0.00244 = \text{KW}$$

$$\text{KW} \times 410 \div \text{GPH} = \text{_____} \text{ } ^\circ\text{F } \Delta\text{T}$$

$$\text{KW} \times 410 \div \text{_____} \text{ } ^\circ\text{F } \Delta\text{T} = \text{GPH}$$

Note: 1 KW will heat 4.1 GPH at a 100°F ΔT

ELECTRICAL

$$\frac{\text{KW} \times 1000}{\text{Volts}} \div 1.73 = \text{Amps } 3 \Phi$$

$$\frac{\text{KW} \times 1000}{\text{Volts}} = \text{Amps } 1 \Phi$$

METRIC CONVERSION

$$\text{Liters} \times 0.2641 = \text{Gallons}$$

$$\text{Gallons} \times 3.79 = \text{Liters}$$

$$\text{Gallons} \times 0.003785 = \text{m}^3$$

$$\text{m}^3 \times 264.2 = \text{Gallons}$$

$$1^\circ\text{C } \Delta\text{T} = 1.8^\circ\text{F } \Delta\text{T}$$

$$^\circ\text{F} = (^\circ\text{C} \times 1.8) + 32$$

$$^\circ\text{C} = (^\circ\text{F} - 32) \times 0.556$$

$$\text{psi} \times 0.06896 = \text{Bar}$$

$$\text{Bar} \times 14.5 = \text{psi}$$

$$\text{psi} \times 6.86 = \text{kPa}$$

$$\text{kPa} \times 0.1456 = \text{psi}$$

$$\text{Lbs} \times 0.4536 = \text{Kg}$$

$$\text{Kg} \times 2.2 = \text{Lbs}$$

$$\text{Watts/Sq.Cm.} \times 6.4 = \text{Watts/Sq.In.}$$

$$\text{Watts/Sq.In.} \times 0.155 = \text{Watts/Sq.Cm.}$$

3-PHASE ELEMENT CHART

Element Part #	Power (kW)			Immersion Length	Resistance (Ohms)			
	208V	240V	480V		Hairpin	1 Φ	3 Φ DELTA	3 Φ WYE
2-38683N	2.5	3	4	13"	57.6	19.2	57.6	38.6
3-38683N	3	4	5	13"	43.2	14.4	43.2	28.9
4-38683N	4	5	6	13"	34.4	11.5	34.4	23.0
5-38683N	5	6	8	13"	27.9	9.3	27.9	18.7
6-38683N	6	8	10	13"	21.6	7.2	21.6	14.5
7-38683N	8	10	12	13"	17.1	5.7	17.1	11.5
8-38683N	10	12	15	13"	14.4	4.8	14.4	9.6
9-38683N	12	15	20	15"	12.1	4.0	12.1	8.1
10-38683N	15	20	----	15"	9.1	3.0	9.1	6.1
11-38683N	17.3	----	----	15"	7.5	2.5	7.5	5.0

SINGLE PHASE ELEMENT CHART

Element Part #	Power (Watts)					Immersion Length	Element Resistance (Ohms)
	120V	208V	240V	277V	480V		
CH-FO-358	----	3500	----	----	----	11 3/8"	12.36
CH-FO-408	----	4000	----	----	----	11 3/8"	10.82
CH-FO-508	----	5000	----	----	----	13 1/4"	8.65
CH-FO-608	2000	6000	----	----	----	13 3/8"	7.21
CH-FO-304	----	----	3000	4000	----	9 3/4"	19.20
CH-FO-354	----	2500	3500	----	----	9 3/4"	16.46
CH-FO-404	----	3000	4000	----	----	11 1/2"	14.40
CH-FO-454	----	----	4500	----	----	11 1/2"	12.80
CH-FO-504	----	----	5000	----	----	11 1/2"	11.52
CH-FO-604	1500	4500	6000	----	----	13 1/2"	9.60
TGB-1203-480	----	----	----	----	2000	7 5/8"	83.23
TGB-1353-480	----	500	----	1000	3500	12 1/2"	47.56
TGB-2257L	2500	----	----	----	----	9 5/8"	5.76
TGB-1207-240	500	1500	2000	2500	----	13 3/8"	28.80
TGB-1303-480	----	----	----	990	3000	10 1/2"	55.49
TGB-1403-480	----	----	1000	1350	4000	13 5/8"	41.62
TGB-2257-240	----	2000	2500	3500	----	10 5/8"	23.04
TGB-2257-480	----	----	----	----	2500	13 1/4"	66.59
TGB-2457-277	----	----	----	4500	----	13 1/8"	17.05
TGB-2457-480	----	----	----	1500	4500	13 1/4"	36.99
TGB-2503-480	----	1000	----	----	5000	9 3/4"	33.29
TGB-2507-277	----	----	----	5000	----	15"	15.35
TGB-2603-277	----	----	----	6000	----	15 1/2"	12.79
TGB-2603-480	----	----	1500	2000	6000	15 1/2"	27.74

*Red wattage indicates the stamped element rating

TORQUE VALUES

BOLT SIZE	18-8 S/S IN.-LBS.	BRASS IN.-LBS.	SILICON BRONZE IN.-LBS.	ALUMINUM 2024-T4 IN.-LBS.	316 S/S IN.-LBS.	MONEL IN.-LBS.
4-40	5.2	4.3	4.8	2.9	5.5	5.3
4-48	6.6	5.4	6.1	3.6	6.9	6.7
5-40	7.7	6.3	7.1	4.2	8.1	7.8
5-44	9.4	7.7	8.7	5.1	9.8	9.6
6-32	9.6	7.9	8.9	5.3	10.1	9.8
6-40	12.1	9.9	11.2	6.6	12.7	12.3
8-32	19.8	16.2	18.4	10.8	20.7	20.2
8-36	22.0	18.0	20.4	12.0	23.0	22.4
10-24	22.8	18.6	21.2	13.8	23.8	25.9
10-32	31.7	25.9	29.3	19.2	33.1	34.9
1/4-20	75.2	61.5	68.8	45.6	78.8	85.3
1/4-28	94.0	77.0	87.0	57.0	99.0	106.0
5/16-18	132	107	123	80	138	149
5/16-24	142	116	131	86	147	160
3/8-16	236	192	219	143	247	266
3/8-24	259	212	240	157	271	294
7/16-14	376	317	349	228	393	427
7/16-20	400	327	371	242	418	451
1/2-13	517	422	480	313	542	584
1/2-20	541	443	502	328	565	613
9/16-12	682	558	632	413	713	774
9/16-18	752	615	697	456	787	855
5/8-11	1110	907	1030	715	1160	1330
5/8-18	1244	1016	1154	798	1301	1482
3/4-10	1530	1249	1416	980	1582	1832
3/4-16	1490	1220	1382	958	1558	1790
7/8-9	2328	1905	2140	1495	2430	2775
7/8-14	2318	1895	2130	1490	2420	2755
1-8	3440	2815	3185	2205	3595	4130
1-14	3110	2545	2885	1995	3250	3730



THE ELECTRIC HEATER COMPANY

P.O. BOX 288

STRATFORD, CT 06615-0288

PHONE: (203) 378-2659

FAX: (203) 378-3593

INTERNET: <http://www.hubbellheaters.com/>