

# INSTALLATION, OPERATION, AND MAINTENANCE MANUAL FOR CONDENSING GAS STORAGE WATER HEATER

## **Hubbell**<sup>TM</sup> WATER HEATERS

### BASE MODEL “GSE”



**WARNING:** If the information in these instructions is not followed exactly, a fire or explosion may result causing property damage, personal injury or death.

- Do not store or use gasoline or other flammable vapors and liquids in the vicinity of this or any other appliance.
- **WHAT TO DO IF YOU SMELL GAS**
  - Do not try to light any appliance.
  - Do not touch any electrical switch; do not use any phone in your building.
  - Immediately call your gas supplier from a neighbor's phone. Follow the gas supplier's instructions.
  - If you cannot reach your gas supplier, call the fire department.
- Installation and service must be performed by a qualified installer, service agency or the gas supplier.

## Table of Contents

|     |   |    |
|-----|---|----|
| 1.0 | INTRODUCTION .....  | 4  |
|     | Operating Principle .....   | 4  |
|     | Safety Information and Precautions .....                                      | 4  |
|     | Outline Dimensions .....  | 8  |
|     | Electrical .....  | 10 |
|     | Gas .....   | 10 |
| 2.0 | INSTALLATION .....  | 11 |
|     | Installation Safety Notes .....   | 11 |
|     | Installer Responsibilities .....  | 12 |
|     | Water Heater Placement .....  | 12 |
|     | Ventilation .....   | 12 |
|     | Removing an Existing Water Heater from Common Venting System .....            | 13 |
|     | Direct Vent Installation .....  | 13 |
|     | Combustion Air-inlet Contamination .....                                      | 14 |
|     | Water Heater Vent/Air Piping .....  | 14 |
|     | Vent and Air-inlet Pipe Length Determination .....                            | 15 |
|     | Termination– Direct Vent Installation .....                                   | 16 |
|     | Venting Rules and Guidelines: .....   | 20 |
|     | Flammable Solvents and Plastic Piping .....                                   | 23 |
|     | Mandatory Pre-commissioning Procedure for Plastic Venting (PVC or CPVC) ..... | 23 |
|     | Condensate Drain .....  | 24 |
|     | Gas Installation .....  | 25 |
|     | Gas Valve and Burner Set-up .....   | 27 |
|     | Water Piping Installation .....   | 30 |
|     | Space Heating Application .....   | 31 |
|     | Filling the Water Heater .....  | 32 |
|     | Electrical Installation .....   | 32 |
|     | Final Checks .....  | 32 |
|     | Lighting the Water Heater .....   | 33 |
|     | Initial Start-Up .....  | 33 |
|     | Turning Off the Water Heater .....  | 34 |
|     | Turning On the Water Heater .....   | 34 |
| 3.0 | CONTROLLER OPERATION .....  | 34 |
|     | LCD Display .....   | 34 |
|     | Button Layout .....   | 35 |
|     | Temperature Adjustments via Status Overview .....                             | 36 |
|     | Showing Errors on the Status Overview .....                                   | 37 |
|     | User Menu .....   | 37 |
|     | Installer Menu .....  | 38 |
|     | Warnings .....  | 39 |
| 4.0 | SCHEDULED MAINTENANCE .....   | 40 |
|     | Freezing .....  | 40 |
|     | Manual Inspection .....   | 40 |
| 5.0 | TROUBLESHOOTING .....   | 41 |
|     | Controller Error Messages and Procedures .....                                | 42 |
|     | Lockout Codes .....   | 42 |
|     | Blocking Errors .....   | 43 |
| 6.0 | MAINTENANCE & SERVICING .....   | 44 |

Surface Temperature Hi-Limit Cutout Switch .....44  
Removing the Condensate Outlet .....44  
Removing the Fan Assembly.....44  
Heat Exchanger.....44  
Relief Valve.....45  
Heating Element (If Equipped).....45  
7.0 REPLACEMENT OF PARTS.....47  
WARRANTY .....49  
List of Figures.....49  
List of Tables .....51



**! WARNING**

Read and understand instruction manual and safety messages before installing, operating or servicing this water heater.

Failure to follow instructions and safety messages could result in death or serious injury.

Instruction manual must remain with water heater.

## **1.0 INTRODUCTION**

### **Operating Principle**

The Hubbell Condensing Gas Water Heater is a Category IV water heater — a water heater that operates with a positive vent static pressure and with a vent gas temperature that may cause excessive condensate production in the vent. The unit uses combusted gas to transfer heat from the air to water. In comparison, traditional electric water heaters use resistive heating elements to directly heat the water. A benefit of a gas water heater is that gas heaters are less expensive to operate than electric resistance heaters.

This water heater utilizes the natural principles of combustion and fluid dynamics to achieve heat transfer. Natural gas is a combustible substance, and when exposed to flames will combust. This causes the bonds within the molecules to break, releasing the energy contained in these bonds. This energy becomes heat energy and is how the water contained within the tank becomes hot.

After the gas has combusted, it will produce hot carbon dioxide and water vapor. These substances will transfer heat through the stainless steel condensing unit tubing to the water contained within the tank, resulting in hot water.

**HUBBELL HEATER COMPANY  
45 SEYMOUR STREET  
P.O. BOX 288  
STRATFORD, CT 06615**

**PHONE: (203) 378-2659  
FAX: (203) 378-3593  
INTERNET: <http://www.hubbellheaters.com>**

**-- IMPORTANT --**

**Always reference the full model number and serial number when calling the factory.**

### **Safety Information and Precautions**

Please read the following safety information before proceeding:

#### **Hazards and Definitions**

**DANGER:** Indicates a hazardous situation which, if not avoided, will result in serious injury or death.

**WARNING:** Indicates a hazardous situation which, if not avoided, could result in serious injury or death.

**CAUTION:** Indicates a hazardous situation which, if not avoided, could result in minor or moderate injury.

**NOTICE:** Indicates a hazardous situation which, if not avoided, could result in property damage.

**WARNING:** If the information in these instructions is not followed exactly, a fire or explosion may result causing property damage, personal injury or death.



- Do not store or use gasoline or other flammable vapors and liquids in the vicinity of this or any other appliance.
- Installation and service must be performed by a qualified installer, service agency or the gas supplier.
- This water heater does not have a pilot. It is equipped with an ignition device which automatically lights the burner. Do not try to light the burner by hand.
- BEFORE operating, smell around the water heater area for gas. Be sure to smell next to the floor because some gas is heavier than air and will settle on the floor. What to do if you smell gas:
  - Do not try to light any appliance.
  - Do not touch any electric switch.
  - Do not use any phone in your building.
  - Immediately call your gas supplier from a neighbor's phone and follow the gas supplier's instructions.
  - If you cannot reach your gas supplier, call the fire department.
- Use only your hand to push in or turn the gas control knob. Never use tools. If the knob will not push in or turn by hand, don't try to repair it; call a certified service technician. Force or attempted repair may result in a fire or explosion.
- Do not use this water heater if any part has been under water. Immediately call a qualified service technician to inspect the water heater and to replace any part of the control system and any gas control which has been underwater.

**WARNING:** Void Warranty - This Water heater must be filled with water whenever the burner is on or it will damage the unit and void the warranty. Failure to follow these instructions may result in serious injury or death.



- Water temperature over 125°F can cause severe burns instantly or death from scalds.
- Children, disabled and elderly are at the highest risk of being scalded.
- See instruction manual before setting temperature at the water heater.
- Feel water before bathing or showering.
- Temperature limiting valves are available, see manual.

The temperature of the water in the heater is regulated by an adjustable, automatic, temperature control which uses surface mounted thermistors located behind the jacket. These automatic controls are set at the factory to maintain a water temperature of 120°F. Although these controls are designed to industry standards,

they can fail to control temperature properly without any notice, and therefore should be tested periodically for your protection.

To perform the test: Turn on the hot water faucet and measure the maximum temperature with an accurate thermometer. If the temperature is above the safe limits for your circumstances call a service technician to adjust or replace the control.

**DANGER:** IF YOU DISCOVER EXTREME HOT WATER COMING FROM THE FAUCET, IMMEDIATELY SHUT OFF THE ELECTRICITY AND GAS AT THE MAIN SWITCH AND CALL COMPETENT SERVICE PERSONNEL. ANY OVERHEATED WATER HEATER IS A POTENTIAL HAZARD TO LIFE AND PROPERTY. DO NOT OPERATE UNTIL THE SOURCE OF THE PROBLEM HAS BEEN DETERMINED AND ELIMINATED.

**WARNING:** Corrosion of the flue ways and vent system may occur if air for combustion contains certain chemical vapors. This can result in failure and risk of suffocation.

**WARNING:** Attic and/or exhaust fans operating in conjunction with a water heater can result in carbon monoxide poisoning and death.

\*Operating these fans can produce a negative draft in the area of the water heater and prevent the products of combustion from exhausting through the chimney or vent pipe. The venting of the water heater should be inspected by a qualified service technician at the time of installation and periodically thereafter to ensure a down-draft condition does not exist. Do not obstruct the flow of combustion and ventilating air.

**WARNING:** Generally, after two weeks or more of non-use, hydrogen gas can be produced in a hot water system. Hydrogen gas is extremely flammable. To reduce risk of injury caused by this hydrogen, it is recommended to run the hot water faucet for several minutes at the kitchen sink before using any electrical appliance connected to the hot water system. If hydrogen is present, typically there will be an unusual noise similar to air escaping through the pipes. There should be no smoking or open flame near the faucet at the time it is open.

**NOTICE:** Should overheating occur or the gas supply fails to shut off, turn off the manual gas control valve to the appliance.

**IN THE STATE OF MASSACHUSETTS ONLY**  
**(Check up to date local codes and regulations for other jurisdictions)**

(a) For all horizontally vented gas fueled equipment installed in every dwelling, building or structure used in whole or in part for residential purposes, including those owned and operated by the Commonwealth and where the side wall exhaust vent termination is less than seven (7) feet above finished grade in the area of the venting, including but not limited to decks and porches, the following requirements shall be satisfied:

1. **INSTALLATION OF CARBON MONOXIDE DETECTORS** At the time of installation of the side wall horizontal vented gas fueled equipment, the installing plumber or gas fitter shall observe that a hard wired carbon monoxide detector with an alarm and battery back-up is installed on the floor level where the gas equipment is to be installed and on each additional level of the dwelling, building or structure served by the equipment. It shall be the responsibility of the property owner to secure the services of qualified licensed professionals for the installation of hard wired carbon monoxide detectors.
  - a. In the event that the side wall horizontally vented gas fueled equipment is installed in a crawl space or an attic, the hard wired carbon monoxide detector with alarm and battery back-up may be installed on the next adjacent floor level.
  - b. In the event that the requirements of this subdivision cannot be met at the time of completion of installation, the owner shall have a period of 30 days to comply with the above requirements; provided, however, that during said 30 day period a battery operated carbon monoxide detector with an alarm shall be installed.
2. **APPROVED CARBON MONOXIDE DETECTORS** Each carbon monoxide detector as required in accordance with the above provisions shall comply with NFPA 720 and be ANSI/UL 2034 listed and IAS certified.
3. **SIGNAGE** A metal or plastic identification plate shall be permanently mounted to the exterior of the building at a minimum height of eight (8) feet above grade directly in line with the exhaust vent terminal for the horizontally vented gas fueled heating water heater or equipment. The sign shall read, in print size no less than one-half (1/2) inch in size, "GAS VENT DIRECTLY BELOW. KEEP CLEAR OF ALL OBSTRUCTIONS" (plate included with water heater).
4. **INSPECTION** The state or local gas inspector of the side wall horizontally vented gas fueled equipment shall not approve the installation unless, upon inspection, the inspector observes carbon monoxide detectors and signage installed in accordance with the provisions of 248 CMR 5.08(2)(a)1 through 4.

(b) **EXEMPTIONS:** The following equipment is exempt from 248 CMR 5.08(2)(a)1 through 4:

1. The equipment listed in Chapter 10 entitled "Equipment Not Required To Be Vented" in the most current edition of NFPA 54 as adopted by the Board; and
2. Product Approved side wall horizontally vented gas fueled equipment installed in a room or structure separate from the dwelling, building or structure used in whole or in part for residential purposes.

(c) **MANUFACTURER REQUIREMENTS – GAS EQUIPMENT VENTING SYSTEM PROVIDED:** When the manufacturer of Product Approved side wall horizontally vented gas equipment provides a venting system design or venting system components with the equipment, the instructions provided by the manufacturer for installation of the equipment and the venting system shall include:

1. Detailed instructions for installation of the venting system design or the venting system components; and
2. A complete parts list for the venting system design or venting system.

(d) **MANUFACTURER REQUIREMENTS – GAS EQUIPMENT VENTING SYSTEM NOT PROVIDED:** When the manufacturer of a Product Approved side wall horizontally vented gas fueled equipment does not provide the parts for venting the flue gases, but identifies "special venting systems", the following requirements shall be satisfied by the manufacturer:

1. The referenced "special venting system" instructions shall be included with the water heater or equipment installation instructions; and
2. The "special venting system" shall be Product Approved by the Board, and the instructions for that system shall include a parts list and detailed installation instructions.

(e) A copy of all installation instructions for all Product Approved side wall horizontally vented gas fueled equipment, all venting instructions, all parts list for venting instructions, and/or all venting design instructions shall remain with the water heater or equipment at the completion of the installation.

# Outline Dimensions

## Figure 1 - Tank Assembly (55k Btu Unit on top, 110k Unit on bottom)

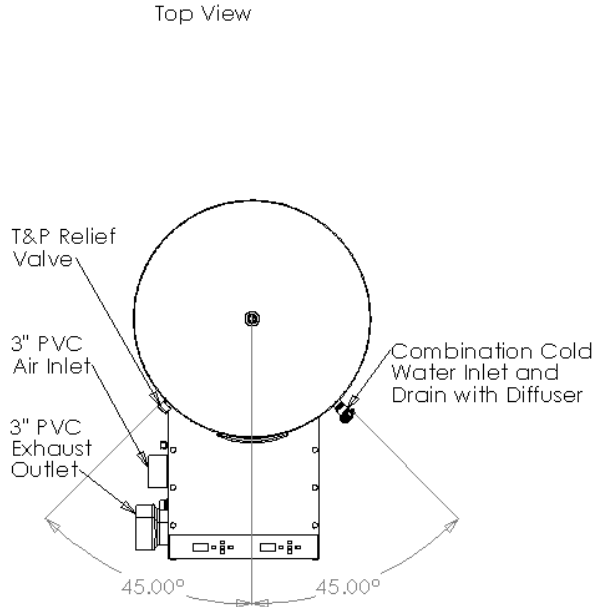
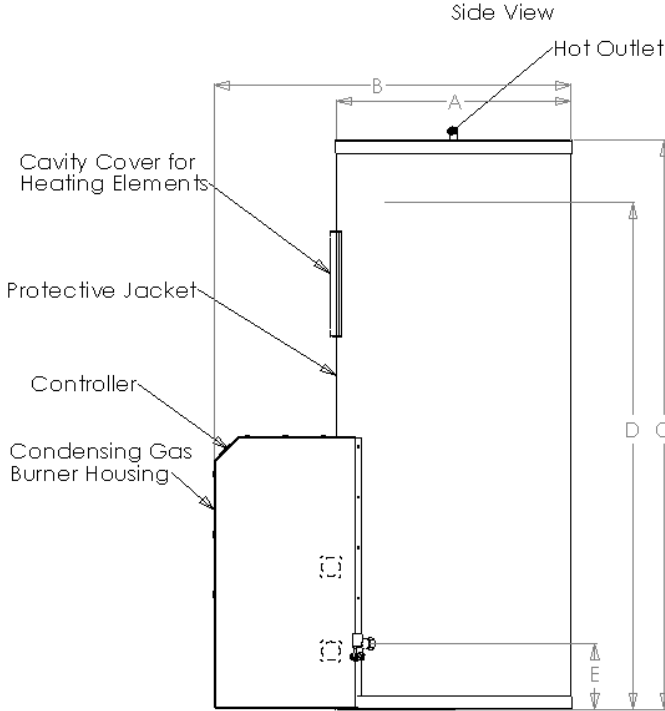
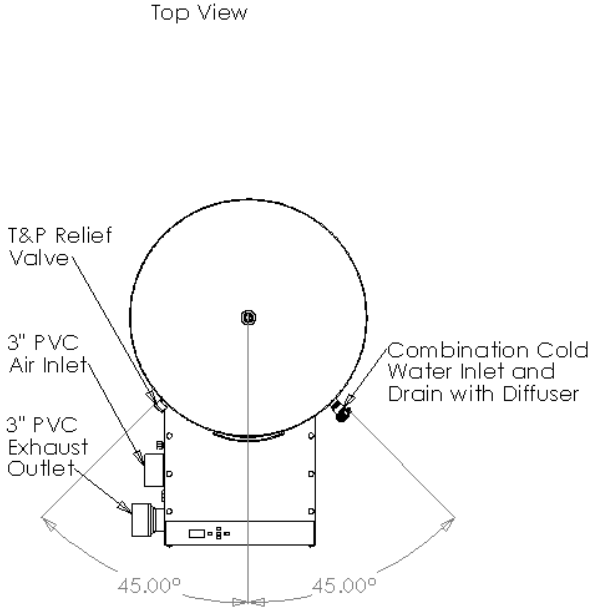
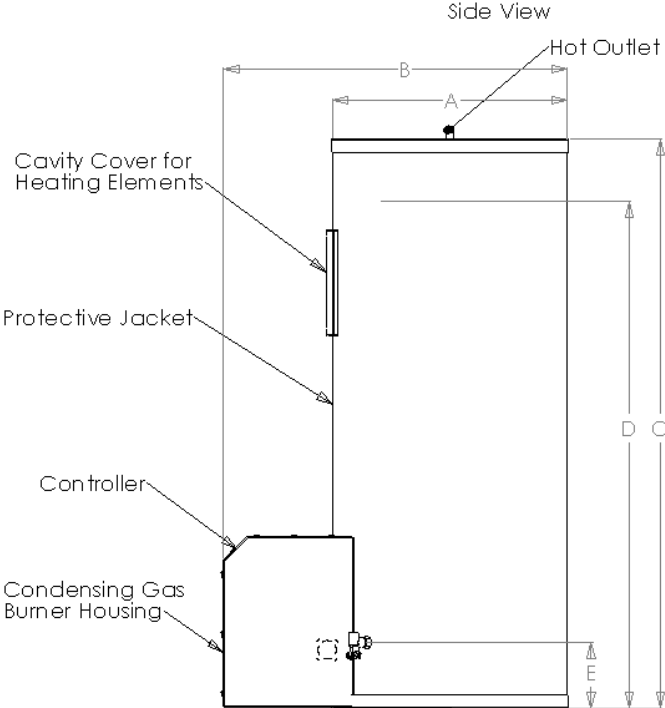

**Table 1- Model Specific Dimensional Data**

| Base Model Number | Storage Capacity (Gallons) | Dimensions (Inches) |                   |                    |                           |                               | Shipping Weight (lbs.) |
|-------------------|----------------------------|---------------------|-------------------|--------------------|---------------------------|-------------------------------|------------------------|
|                   |                            | Tank Diameter "A"   | Overall Depth "B" | Overall Height "C" | Floor to Relief Valve "D" | Floor to Cold Water Inlet "E" |                        |
| GSE55-C-40SL      | 40                         | 26                  | 38.625            | 31.5               | 25.25                     | 7.75                          | 246                    |
| GSE55-C-50SL      | 50                         | 28                  | 40.625            | 36                 | 27.5                      | 7.75                          | 286                    |
| GSE55-C-65SL      | 65                         | 26                  | 38.625            | 46.25              | 39.375                    | 7.875                         | 294                    |
| GSE55-C-80SL      | 80                         | 26                  | 38.625            | 57.25              | 49.875                    | 7.875                         | 351                    |
| GSE55-C-100SL     | 100                        | 26                  | 38.625            | 67.50              | 60.375                    | 7.875                         | 409                    |
| GSE55-C-120SL     | 120                        | 28                  | 40.625            | 67.75              | 60.375                    | 7.875                         | 438                    |
| GSE110-C-40SL     | 40                         | 26                  | 40.025            | 31.5               | 25.25                     | 7.75                          | 286                    |
| GSE110-C-50SL     | 50                         | 28                  | 42.025            | 36                 | 27.5                      | 7.75                          | 326                    |
| GSE110-C-65SL     | 65                         | 26                  | 40.025            | 46.25              | 39.375                    | 7.875                         | 334                    |
| GSE110-C-80SL     | 80                         | 26                  | 40.025            | 57.25              | 49.875                    | 7.875                         | 411                    |
| GSE110-C-100SL    | 100                        | 26                  | 40.025            | 67.50              | 60.375                    | 7.875                         | 469                    |
| GSE110-C-120SL    | 120                        | 28                  | 42.025            | 67.75              | 60.375                    | 7.875                         | 498                    |

## **Electrical**

- This water heater has a power cord with a standard 120V three-prong plug.
- Power cord should be plugged directly into a proper 120V wall outlet. Power strips and extension cords should not be used.
- Maximum amperage draw is .7 amps for single heat exchanger model, 1.4 amps for double heat exchanger model.

## **Gas**

- The maximum BTU input is 55,000 BTU per hour for single heat exchanger model, 110,000 BTU per hour for double heat exchanger model.
- The minimum BTU input is 18,000 BTU per hour.
- This water heater has a 1/2 inch female NPT gas fitting.
- See Gas Installation section for more information.



## 2.0 INSTALLATION

### **WARNING / CAUTION**

DO NOT TURN ON THE ELECTRIC POWER SUPPLY to this equipment until heater is completely filled with water and all air has been released. *If the heater is NOT filled with water when the power is turned on, the heating elements will burn out (if equipped), and can cause damage to gas heat exchanger.*

For protection against excessive pressures and temperatures, local codes require the installation of a temperature-and-pressure (T&P) relief valve certified by a nationally recognized laboratory that maintains periodic inspection of production of listed equipment of materials, as meeting the requirements for Relief Valves and Automatic Gas Shutoff for Hot Water Supply Systems, ANSI Z21.22. THE CUSTOMER IS RESPONSIBLE TO PROTECT PROPERTY AND PERSONNEL FROM HARM WHEN THE VALVE FUNCTIONS.

All water heaters have a risk of leakage at some unpredictable time. IT IS THE CUSTOMER'S RESPONSIBILITY TO PROVIDE A CATCH PAN OR OTHER ADEQUATE MEANS, SO THAT THE RESULTANT FLOW OF WATER WILL NOT DAMAGE FURNISHINGS OR PROPERTY.

Before doing anything, inspect the tank and all parts to assure that no parts are faulty or damaged from shipping.

### **Installation Safety Notes**

1. Tank is to be completely filled with water and all air is to be vented before energizing. Do not turn on water heater if cold water supply shut off valve is closed.
2. Due to the rigors of transportation, all connections should be checked for tightness before heater is placed in operation.
3. Safety relief valve must be installed in the tapping provided.
4. The refractory material used in heating elements may absorb some moisture during transit, periods of storage, or when subjected to a humid environment. This moisture absorption results in a cold insulation resistance of less than twenty (20) megohms. If this heater has been subjected to the above condition, each heating element must be checked for insulation resistance before energizing. A low megohm condition can be corrected by removing the terminal hardware and baking the element in an oven at 350°F -700°F for several hours or until the proper megohm reading is obtained.
5. **KEEP AWAY FROM LIVE ELECTRICAL CIRCUITS.**  
Do not perform any maintenance, make any adjustments, or replace any components inside the control panel with the high voltage power supply turned on. Under certain circumstances, dangerous potentials may exist even when the power supply is off. To avoid casualties, always turn the power supply safety switch to off, turn the charge or ground the circuit before performing any maintenance or adjustment procedure.
6. The unit is designed to operate at pressure not more than 150 psi.
7. Generalized instructions and procedures cannot anticipate all situations. For this reason, only qualified installers should perform the installations. A qualified installer is a person who has licensed training and a working knowledge of the applicable codes regulation, tools, equipment, and methods necessary for safe installation of an electric resistance water heater. If questions regarding installation arise, check your local plumbing and electrical inspectors for proper procedures and codes. If you cannot obtain the required information, contact the company.

8. In the event of overheating, fire, flood, or physical damage, turn off all power and gas to your water heater. Do not power the heater until it has been examined by a trained professional.
9. Do not store or use gasoline or other flammable vapors and liquids, such as adhesives or paint thinner, in the vicinity of this water heater. If such flammable materials must be used near the unit, open nearby doors and windows to allow for ventilation.

### **Installer Responsibilities**

A qualified installer is a licensed person who has appropriate training and a working knowledge of the applicable codes, regulations, tools, equipment and methods necessary to install a water heater. The Installer assumes all responsibility for a safe installation and that it meets the requirements of the water heater instruction manuals, as well as National and local installation codes. It is also the installer's responsibility to inform the User/Owner of their obligation with respect to the description under "User Responsibilities". Failure to follow this warning could result in fire, serious injury, or death.

### **Water Heater Placement**

1. Place the heater on a solid foundation in a clean, dry location nearest to the point of most frequent hot water use. If the heater is to be raised off the floor, the entire bottom of the heater should be supported by a solid surface.
2. The water heater must be installed with a minimum clearance of 12" on top of the water heater, 24" in front of the housing, and 18" to the left of the housing.
3. If the water heater is installed directly on carpeting, a metal or wood panel extending beyond the full width and depth of the appliance by at least 3 in (76.2 mm) in any direction. If the water heater is installed in an alcove or closet, the entire floor shall be covered by the panel.
4. Do not install in an area where flammable liquids or combustible vapors are present.
5. The water heater should be protected from freezing and waterlines insulated to reduce energy and water waste.
6. Locations with warmer ambient air (ex. furnace rooms) are more advantageous as they provide "free" heat.
7. The water heater will produce exhaust gas which must be piped outdoors, so installation must be in a location where proper ventilation can be set up. See the following section on venting for proper installation of ventilation.

**NOTICE:** If a water heater is installed in a closed water supply system, such as one having a backflow preventer in the cold water supply line, means shall be provided to control thermal expansion. Contact the water supplier or local plumbing inspector on how to control this situation.

**WARNING:** Do not store or use gasoline or other flammable vapors and liquids in the vicinity of this or any other appliance. Failure to follow instructions could result in explosion causing property damage, serious injury, or death.

### **Ventilation**

The Hubbell Condensing Gas Water Heater is a water heater requiring a "direct venting system" designed for pressurized venting. The exhaust vent must be piped to the outdoors, using the vent materials and rules outlined in this section. Under no conditions may this unit vent gases into a masonry chimney unless it is vacant and utilizes the approved venting material and rules.

**NOTE:** Common venting or two separate direct vents can be used if you are installing a 110k Btu unit, as this unit has two separate condensing heat exchangers that need exhaust to be vented outdoors. If this unit is

commonly vented, it may only be commonly vented with itself and must satisfy all relating safety codes and regulations including use of backflow preventers and increasing pipe diameter when additional exhaust lines connect. It is recommended to increase the pipe diameter to at least 4" PVC if the exhaust lines are combined.

**DANGER:** Vent and Air-inlet are to be piped separately. This water heater cannot share a common vent or air-inlet with multiple appliances. Failure to comply will result in serious injury or death.

### **Removing an Existing Water Heater from Common Venting System**

**DANGER:** Do not install this water heater into a common venting system with any other appliances. Failure to comply with this warning will cause flue gas spillage and leech carbon monoxide emissions into the surrounding air resulting in serious injury or death.

**WARNING:** When an existing water heater is removed from a common venting system, the common venting system is likely to be too large for proper venting of the remaining appliances connected to it.

### **Direct Vent Installation**

As a direct vent water heater, the combustion air-inlet must also be piped directly to the outdoors using the methods described in this section and in accordance with the National Fuel Gas Code, ANSI Z223.1 (U.S.), or CSA B149.1 (Canada) and local requirements.

**Figure 2 - Ventilation Connections**

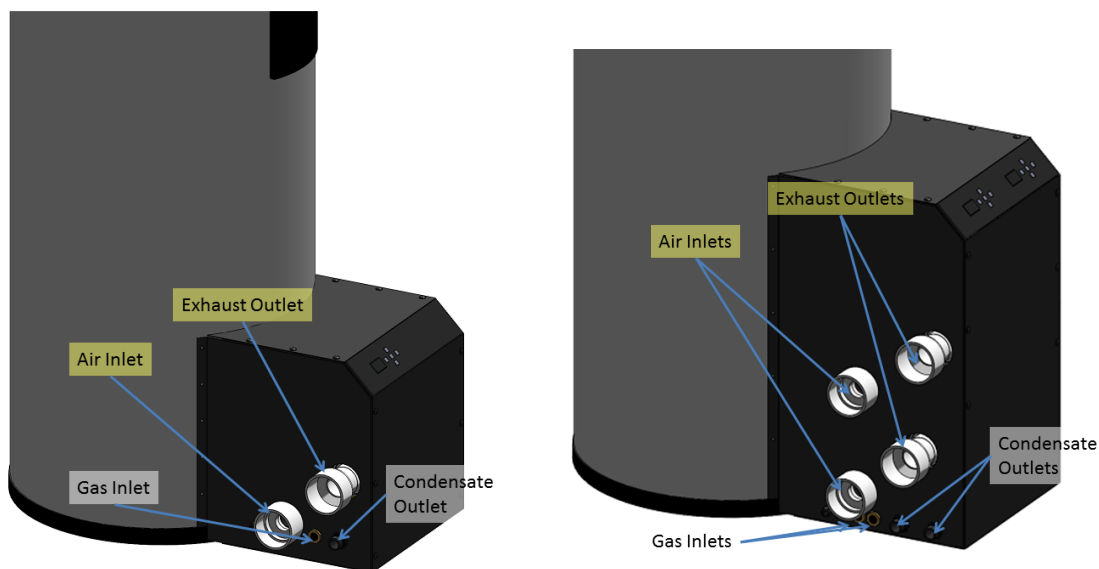

Single Unit Heater on Left, Double Unit Heater on Right

**WARNING:** Make up air requirements for the operation of exhaust fans, kitchen ventilation systems, clothes dryers, and fireplaces shall be considered in determining the adequacy of a space to provide combustion air requirements. Failure to ensure adequate make up air to all appliances may result in personal injury or death.

**NOTICE:** The water heater shall be located so as not to interfere with proper circulation of combustion, ventilation, and dilution of air.

## **Combustion Air-inlet Contamination**

Be careful not to locate the air-inlet termination in an area where contaminants can be drawn in and used for combustion. When deciding on a location for the vent and combustion air-inlet terminals on an exterior wall, be sure to allow at least 12 in. between them to prevent drawing in exhaust with the air. These terminals should also be located at least 1 ft. above grade or average snowfall height (whichever height is greater) to prevent blockage. Combustion air containing dust, debris, or airborne contaminants will drastically increase the required maintenance and may cause a corrosive reaction in the heat exchanger, which could result in premature failure, fire, serious injury, or death. See the following table for a list of areas to avoid when terminating air-intake piping.

**Table 2 - Possible Ventilation Contaminants**

| <b>Products to Avoid</b>  | <b>Contaminated Sources to Avoid</b>              |
|---|---|
| Antistatic fabric softeners, bleaches, detergents, cleaners       | Laundry facilities                                |
| Perchloroethylene (PCE), hydrocarbon based cleaners               | Dry cleaning facilities                           |
| Chemical fertilizer, herbicides/pesticides, dust, methane gas     | Farms or areas with livestock and manure          |
| Paint or varnish removers, cements or glues, sawdust              | Wood working or furniture refinishing shops       |
| Water chlorination chemicals (chloride, fluoride)                 | Swimming pools, hot tubs                          |
| Solvents, cutting oils, fiberglass, cleaning solvents             | Auto body or metal working shops                  |
| Refrigerant charge with CFC or HCFC                               | Refrigerant repair shops                          |
| Permanent wave solutions  | Beauty shops                                      |
| Fixer, hydrochloric acid (muriatic acid), bromide, iodine         | Photo labs, chemical / plastics processing plants |
| Cement powder, crack fill dust, cellulose, fiber based insulation | Concrete plant or construction site               |

**WARNING:** Do not store or use gasoline or other flammable vapors and liquids in the vicinity of this or any other appliance. Failure to follow instructions may result in serious injury or death.

## **Water Heater Vent/Air Piping**

Each water heater is equipped with a (or two, if you have the 110k Btu dual heat exchanger unit) short piece(s) of approved CPVC vent pipe. Insert one end into the water heater flue outlet adapter and cement the other to field venting. The CPVC vent pipe should extend fully into the water heater flue outlet adapter and seal with the O-ring provided. Ensure that the venting system does not apply a load or strain on the water heater flue outlet adapter. The manufacturer recommends using two elbows to create a swing joint to reduce potential strain on vent piping and cemented joints.

**WARNING:** Gasket Seating – Improper seating can cause leakage and eventual failure of the sealing gasket. Failure to follow these instructions may result in serious injury or death.

**WARNING:** PVC Exhaust Venting – DO NOT insert PVC pipe directly into the water heater exhaust adapter as it may not seat in the adapter. Use only the manufacturer supplied PVC pipe. Failure to follow these instructions may result in gasket failure and/or the dislodging of the exhaust pipe from the water heater adapter, resulting in property damage, serious injury, or death.

**WARNING:** Polypropylene or Stainless Steel Venting – When using polypropylene or stainless steel piping, the appropriate water heater adapters must be used to transition the water heater vent connections to accept the respective polypropylene or stainless steel venting. Failure to use the correct adapter will result in flue gas leakage resulting in property damage, serious injury, or death.

**DANGER:** Exhaust venting must be supported to reduce strain on piping joints. Failure to follow these instructions may result in damage, serious injury, or death.

**NOTICE:** In Canada, the first 3 ft (915mm) of vent piping must be readily accessible for inspection.

**Table 3 - Vent/Air-inlet Pipe Materials**

| Items                    | Materials          | Installation Standards |  |
|--------------------------|--------------------|------------------------|--|
|                          |                    | United States          | Canada   |
| Vent Piping and Fittings | PVC - DWV          | ANSI/ASTM D2265        | All venting material in Canada must be <b>ULC S636 approved.</b> |
|                          | PVC Schedule 40    | ANSI/ASTM D1785        |  |
|                          | CPVC Schedule 40   | ANSI/ASTM F441         |  |
|                          | AL29-4C            | UL-1738                |  |
|                          | Polypropylene (PP) | -                      |  |
| Pipe Cement              | PVC                | ANSI/ASTM D2564        |  |
|                          | CPVC               | ANSI/ASTM F493         |  |
| Primers                  | PVC / CPVC         | ANSI/ASTM F656         |  |

**WARNING:** All vent and air-inlet-materials installed on gas fired appliances in CAN/US must meet the standards for the region in which they are installed. Failure to comply may result in fire, serious injury, or death.

**WARNING:** The use of cellular core PVC (ASTM F891), cellular core CPVC, or Radel (polyphenol-sulfone) in the exhaust venting system is prohibited. Failure to follow these instructions may result in property damage, personal injury, or death.

**WARNING:** Covering non-metallic vent pipe and fittings with thermal insulation is prohibited. Failure to follow these instructions may result in property damage, personal injury, or death.

### **Vent and Air-inlet Pipe Length Determination**

Use the provided inlet and outlet adapters to attach duct work to the water heater. When using 3” piping, an additional adapter is required from 2” to 3”.

Use the table below to determine the maximum pipe length that can be used. The table calculates sweep, 90° elbows, and 45° elbows at 10 equivalent feet each.

**Table 4 - Combined Length of Vent and Air-Inlet Per Water Heater  
(Single Heat Exchanger Ventilation)**

|           |          | Number of 90° and 45° Elbows                   |    |    |    |    |    |    |    |    |
|-----------|----------|--|----|----|----|----|----|----|----|----|
|           |          | 0  | 1  | 2  | 3  | 4  | 5  | 6  | 7  | 8  |
| Pipe Size | Gas Type | Maximum Combined Vent and Fitting Length (ft.) |    |    |    |    |    |    |    |    |
| 2”        | NG       | 40   | 30 | 20 | 10 | -  | -  | -  | -  | -  |
| 3”        | NG       | 100  | 90 | 80 | 70 | 60 | 50 | 40 | 30 | 20 |

**Table 5 – Combined Length of Vent and Air-Inlet Per Water Heater**

Rev: 3/8/21

**(Common Vented Double Unit)**

|           |          | Number of 90° and 45° Elbows                   |     |     |     |     |     |    |    |    |
|-----------|----------|--|-----|-----|-----|-----|-----|----|----|----|
|           |          | 0  | 1   | 2   | 3   | 4   | 5   | 6  | 7  | 8  |
| Pipe Size | Gas Type | Maximum Combined Vent and Fitting Length (ft.) |     |     |     |     |     |    |    |    |
| 3"        | NG       | 35   | 25  | 15  | 5   | -   | -   | -  | -  | -  |
| 4"        | NG       | 150  | 140 | 130 | 120 | 110 | 100 | 90 | 80 | 70 |

**NOTICE:** 1 foot of piping minimum required before first elbow.

**NOTICE:** The length of one vent pipe (air-inlet or exhaust) may not exceed the length of the other vent pipe by more than 20 equivalent feet.

### **Termination– Direct Vent Installation**

The venting system of this water heater must be terminated using field supplied piping to construct a “Two-Pipe” termination.

**IMPORTANT:** PVC In Canada – Authorities in some jurisdictions may not allow the use of any PVC venting materials with condensing water heaters; check with the local safety inspector to verify compliance prior to installing a PVC Vent Kit with a water heater.

Sidewall Terminations

Figure 3 - Two Pipe Termination (Sidewall)

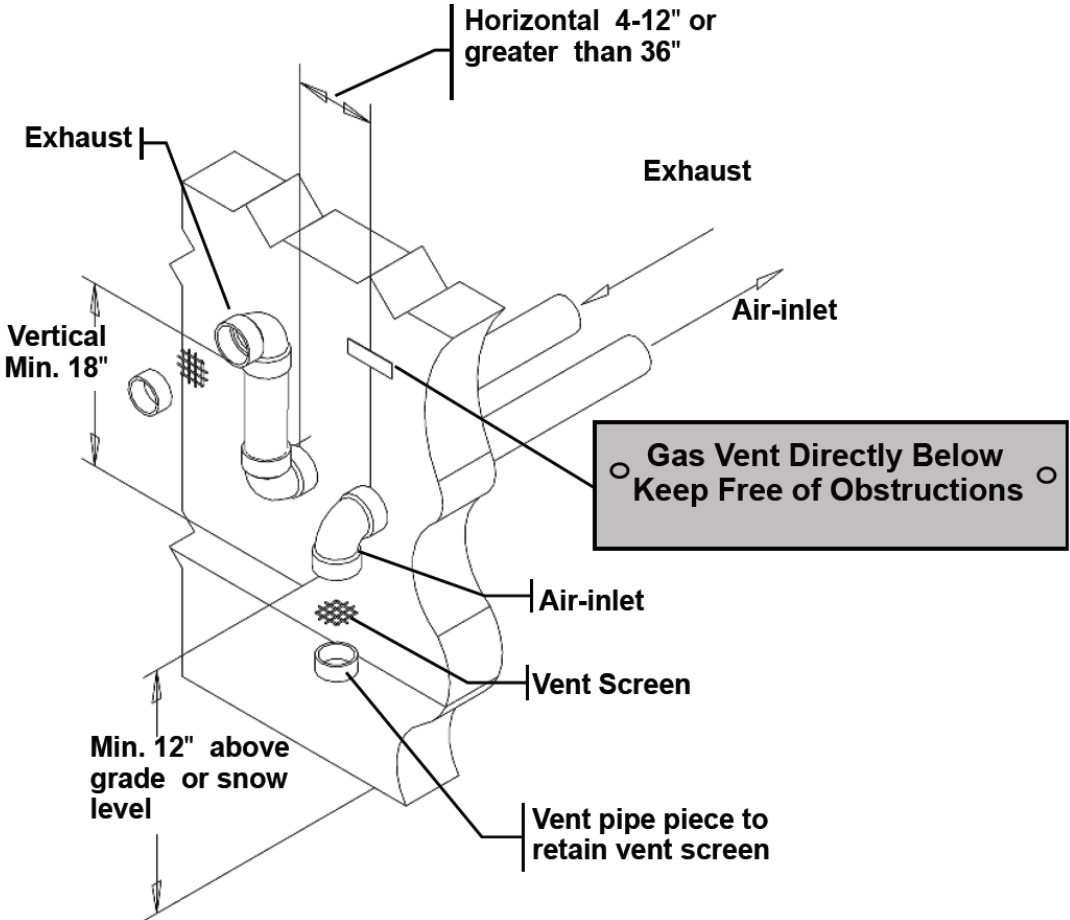

Figure 4 - Two Pipe Low Profile Termination (Sidewall)

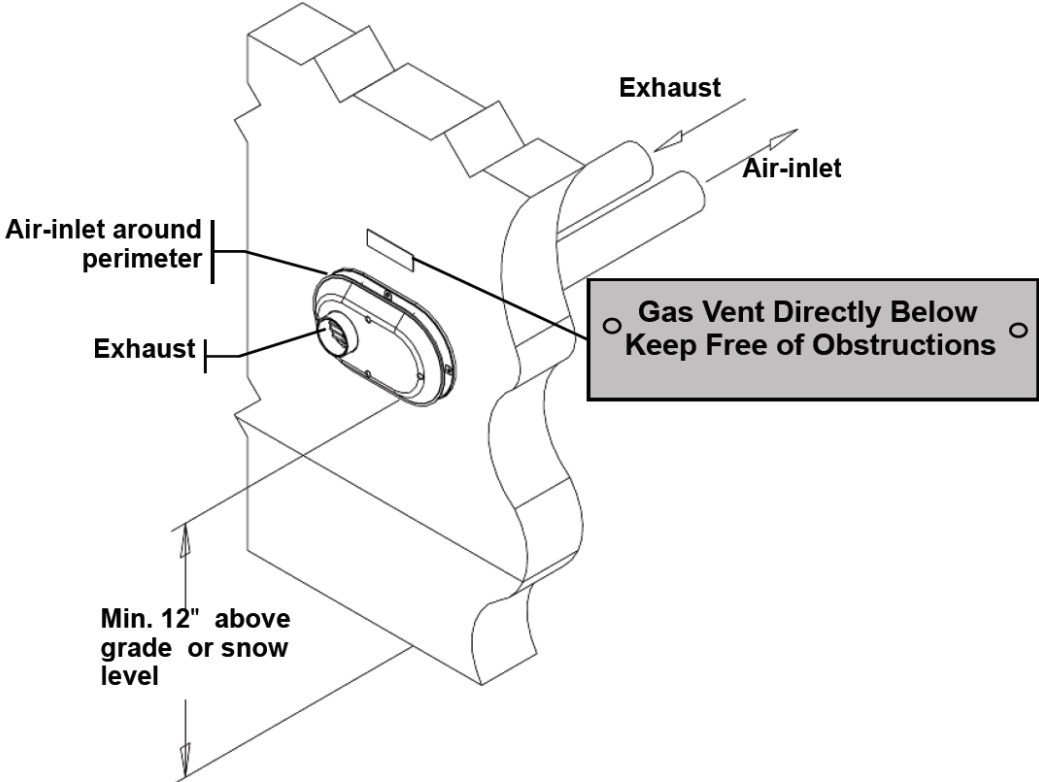
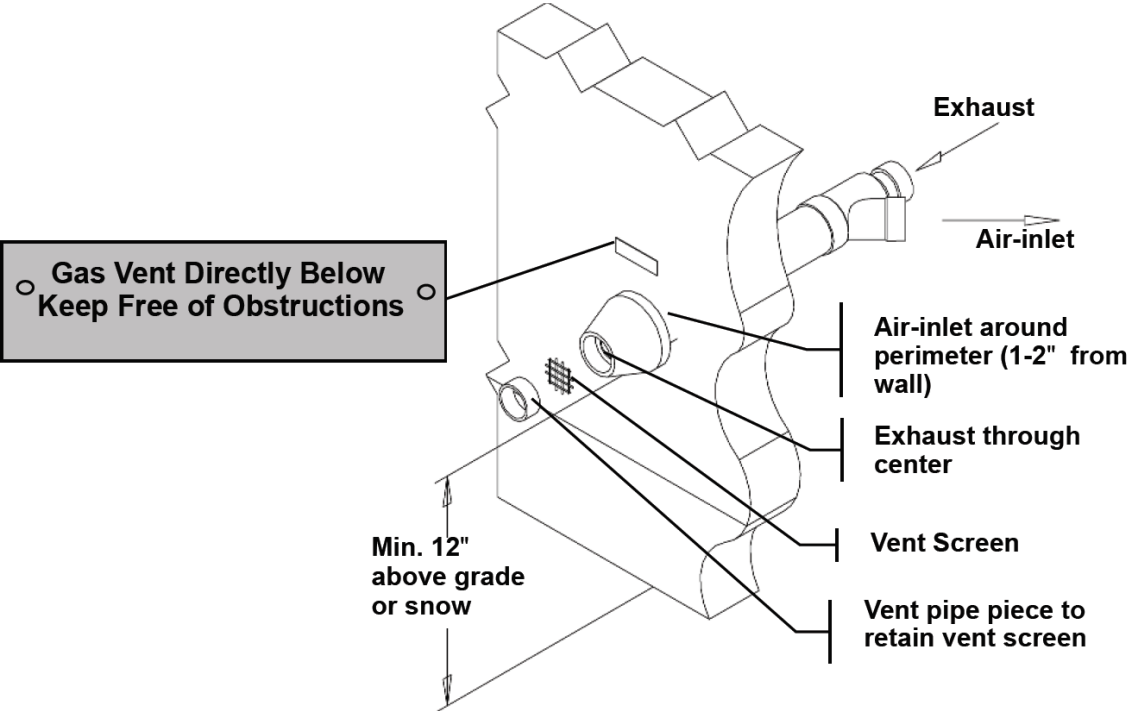

Figure 5 - Two Pipe Concentric Termination (Sidewall)



Roof Terminations

Figure 6 - Two Pipe Termination (Roof)

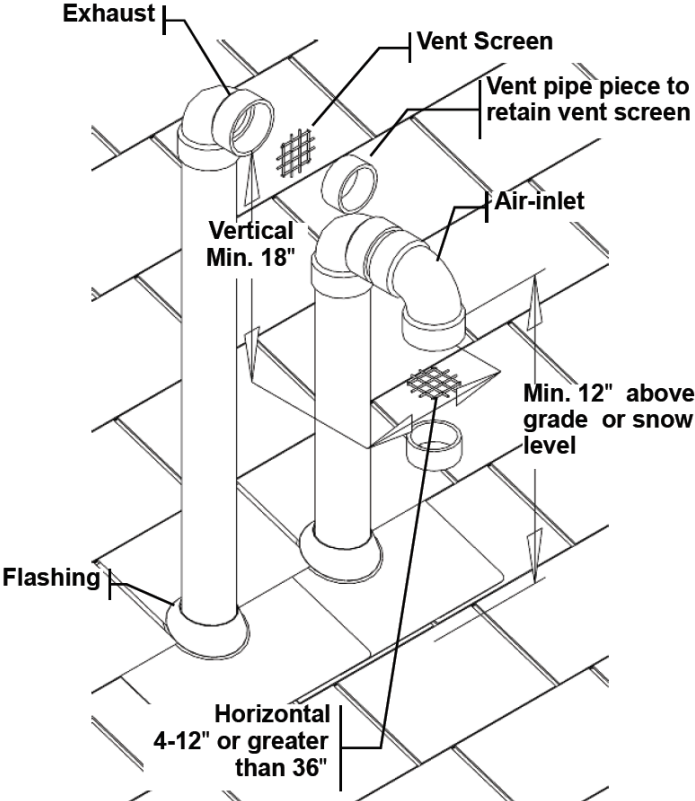
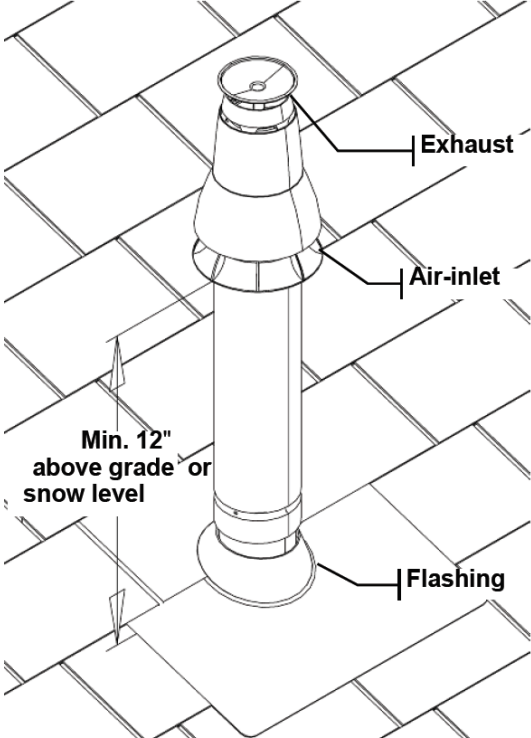

Figure 7 - Two Pipe Concentric Termination (Roof)



**Venting Rules and Guidelines:**

1. Prevailing Winds: Ensure the vent is located where it will not be exposed to normal prevailing winds.
2. Combustion Air-inlet Contamination: Air for combustion must be drawn from an area free of dust and contaminants. Combustion air containing chemicals such as chloride, fluoride, bromine, iodine, or dust and debris will cause corrosion damage of the heat exchanger voiding your Hubbell warranty.
3. Vertical Separation: The exhaust must be a minimum of 18 inches above the air inlet, and the air inlet must always be a minimum of 12 inches plus snow allowance above any surface that will support snow (two feet plus snow allowance is highly recommended). Consult your weather office for the maximum typical snowfall for your region.
4. Horizontal Separation: The horizontal distance between the inlet and exhaust must be a minimum of 4 inches center to center.
5. Wall Flashing: Under normal operating conditions this water heater will produce a plume of white gases and should be taken into consideration when selecting an adequate location. A 36 inch diameter stainless, plastic, or vinyl shield can be used to flash the exterior of the building.
6. Flue Gas Hazard: Position the vent termination where vapors cannot make accidental contact with people and pets or damage nearby shrubs or plants.
7. Elbow Extension: Elbows on the outside of a wall must be no more than ½” away from the wall.
8. Vent Sloping: All indoor exhaust piping must be on a slope back to the water heater a minimum of ¼” per linear foot of vent. For applications where excessive condensation is possible, ½” per linear foot is recommended.
9. Vent supports: Where required, vent and air-inlet piping shall be secured to the wall for more rigidity. All interior vent pipe shall be supported a minimum of every 36 inches.
10. Roof Exhaust: In all roof applications the discharge must point away from the pitch of the roof.
11. Roof Flashing: Install adequate flashing where the pipe enters the roof to prevent water leakage.
12. Rain Cap: Install and seal a rain cap over existing chimney openings in vacant chimney applications.
13. Venting Below Grade: For installations that exit the wall below grade, refer to Figure 8.
14. Condensate Hazard: Do not locate vent over public walkways, driveways, or parking lots. Condensate could drip and freeze resulting in slip hazard or damage to vehicles and machinery.
15. Warning Plate: For sidewall venting, install a warning plate “Gas Vent Directly Below” directly above (within 4 ft. vertically) the location of the air-inlet pipe so it is visible from at least 8 ft. away.
16. Wall Thickness: Direct vent terminations are designed to work with any standard wall thickness. Installation guidelines for min/max wall thickness are as follows: min.=1 in., max.=60 in..
17. Venting Options: Due to potential moisture loading (build-up) along the exterior wall, sidewall venting may not be the preferred venting option. Refer to Figure 6 and Figure 7 for roof top venting options.

**WARNING:** The vent for this water heater shall not terminate over public walkways or near soffit vents or crawl space vents or other areas where condensate of vapor could create a nuisance or hazard or cause property damage; or where condensate or vapor could cause damage or could be detrimental to the operation of regulators, relief valves, or other equipment.

**Figure 8 –Venting Below Grade**

For installations that exit the wall below grade:

1. Excavate site to a point below where the pipes are to exit as shown.
2. Ensure the wall is fully sealed where the pipes penetrate.
3. The Vent/Air-inlet piping **MUST** be secured to the side of the building above grade, as shown, to provide rigidity.
4. Ensure that the Vent/Air-inlet clearances are maintained.

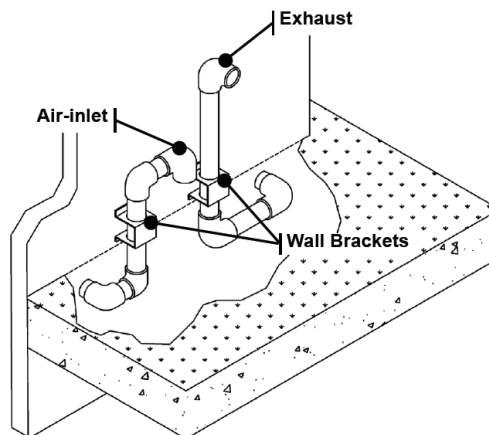
**Figure 9 - Outdoor Venting Guidelines**

Vent piping outside the building is permitted under the following conditions:

1. The maximum length outside the building is 20 ft. Note that outdoor length must be included in the overall vent length calculation.
2. All normal termination clearances are maintained.
3. The pipe is supported every 24 in..
4. The exhaust and inlet are sloped back to the water heater 1/2 in. elevation for every linear foot.

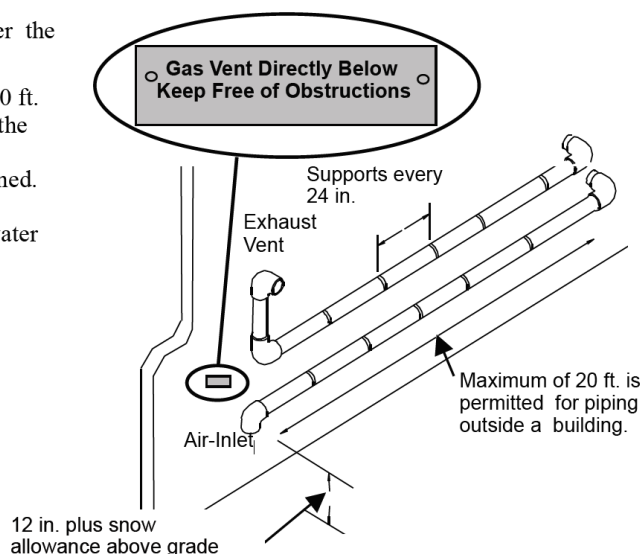
**Figure 10 – Existing Chimney Chase Way**

It is permissible to use an existing chimney as a chase way to run the Vent/Air-inlet piping as long as:

1. The chimney is not being used by any other water heater.
2. Flue gases do not enter the vacant chimney.
3. Only certified venting materials are used.
4. Vent lengths are within the maximums specified.
5. The top of the chimney is capped and the Vent/Air-inlet pipes are flashed to prevent leakage into the vacant chimney.

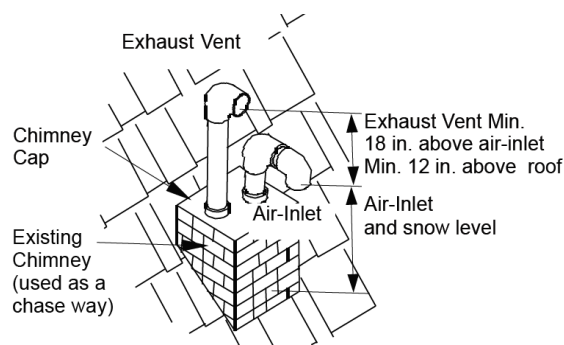

**DANGER:** Under no circumstances may an existing chimney or chase-way be used to vent or provide combustion intake air to the water heater. Failure to follow these instructions will result in fire, property damage, serious injury or death.

**WARNING:** The quick reference table below is to be read in conjunction with the Venting Rules and Guidelines in this section. The instructions detailed in this section are a combination of Hubbell specific and National Gas Code restrictions. Compliance alone doesn't insure a satisfactory installation as good common sense must also be applied. Failure to follow these instructions may result in fire, property damage, serious injury or death.

**Table 6 - Vent and Air-intake Termination Clearances**

| Clearances to Air-Inlet Termination  | USA <sup>1</sup> | Canada <sup>2</sup> |        |
|--|------------------|---------------------|--------|
|  | Min. Distance    | Min. Distance       |        |
| A Above grade/roofline and snow level <sup>8</sup>   | 12 in.           | 12 in.              | 305 mm |
| B Above roof line - Concentric Vent <sup>6, 11, 13</sup>   | 24 in.           | 24 in.              | 610 mm |
| C To exhaust vent from any other water heater  | 36 in.           | 12 in.              | 305 mm |
| Clearances to Exhaust Vent Termination   | Min. Distance    | Min. Distance       |        |
| A Above grade/roofline and snow level <sup>8</sup>   | 12 in.           | 12 in.              | 305 mm |
| D Minimum vertical separation above air inlet <sup>9</sup>   | 18 in.           | 18 in.              | 457 mm |
| E Minimum horizontal separation from air inlet <sup>3</sup>  | 4 in.            | 4 in.               | 102 mm |
| F Window or door that may be opened, or other building opening   | 36 in.           | 12 in.              | 305 mm |
| G To combustion air inlet of any other appliance   | 36 in.           | 12 in.              | 305 mm |
| H Non-mechanical air supply inlet to building  | 36 in.           | 12 in.              | 305 mm |
| I Mechanical air supply inlet to building <sup>4</sup>   | 6 ft.            | 3 ft.               | 915mm  |
| J Soffit, overhang, eave or parapet  | 24 in.           | 24 in.              | 610mm  |
| K Soffit vent or vent opening in an overhang, eave or parapet  | 6 ft.            | 6 ft.               | 1.83 m |
| L Outside corner <sup>10</sup>   | -                | -                   | -      |
| M Inside corner of an L-shaped structure (including walls and fences)  | 36 in.           | 36 in.              | 915 mm |
| N Service regulator / vent outlet  | 36 in.           | 36 in.              | 915mm  |
| P Each side of center line above or below meter / regulator assembly <sup>5</sup>  | 36 in.           | 36 in.              | 915mm  |
| Q Above a paved sidewalk, driveway, or parking lot on public property if adjacent <sup>12</sup>  | 7 ft.            | 7 ft.               | 2.13 m |
| R Above a public walkway   | X                | X                   | X      |
| S Above a sidewalk or paved driveway that is located between two single family dwellings and services both dwellings   | X                | X                   | X      |
| T Under a concrete veranda, porch, deck, or balcony <sup>7</sup>   | 24 in.           | 24 in.              | 610 mm |
| U Above, under or near exterior stairs   | X                | X                   | X      |
| V Into a canopy or carport   | X                | X                   | X      |
| Notes:   |                  |                     |        |
| 1 - Canadian installations must comply with the current CSA B149.1 Natural Gas and Propane Installation Code and local building codes.   |                  |                     |        |
| 2 - US installations must comply with current ANSI Z223.1/ NFPA 54 National Fuel Gas Code and local building codes.  |                  |                     |        |
| 3 - Horizontal separation center-to-center (c.c.) 4"-12" (102-305 mm).   |                  |                     |        |
| 4 - For US installations, an exhaust vent must be 3 ft above a mechanical air supply inlet if within 10 ft. horizontally.  |                  |                     |        |
| 5 - Horizontal clearance must be observed up to a height of 15 ft. [4.6 m] above/below the meter, regulator, or relief devices.  |                  |                     |        |
| 6 - Concentric Vent must protrude from the roof precisely 24"[610 mm] measuring from the terminal end-cap vanes.   |                  |                     |        |
| 7 - Permitted if veranda, porch, deck, or balcony is made of concrete and a minimum of two sides are fully open beneath.   |                  |                     |        |
| 8 - 24" is the recommended snow level allowance above grade/roofline or any surface that will support snow, debris, or ice (i.e. for roof venting clearances - roofline and snow level). If living in a snowfall region, consult your local weather office for the maximum typical snowfall for your area. |                  |                     |        |
| 9 - Note that the vent must maintain a minimum vertical distance above the air-inlet. Example: Vent height = 18" (457 mm) above air inlet + 12" (305 mm) for air inlet above grade/roof line and snow level = 30" (762 mm) above grade and snow level.   |                  |                     |        |
| 10 - Clearances to an outside corner to be in accordance with local installation codes.  |                  |                     |        |
| 11 - In Canada, concentric vent materials are subject to approval by local inspectors.   |                  |                     |        |

Figure 11 - Basic Ventilation Layout

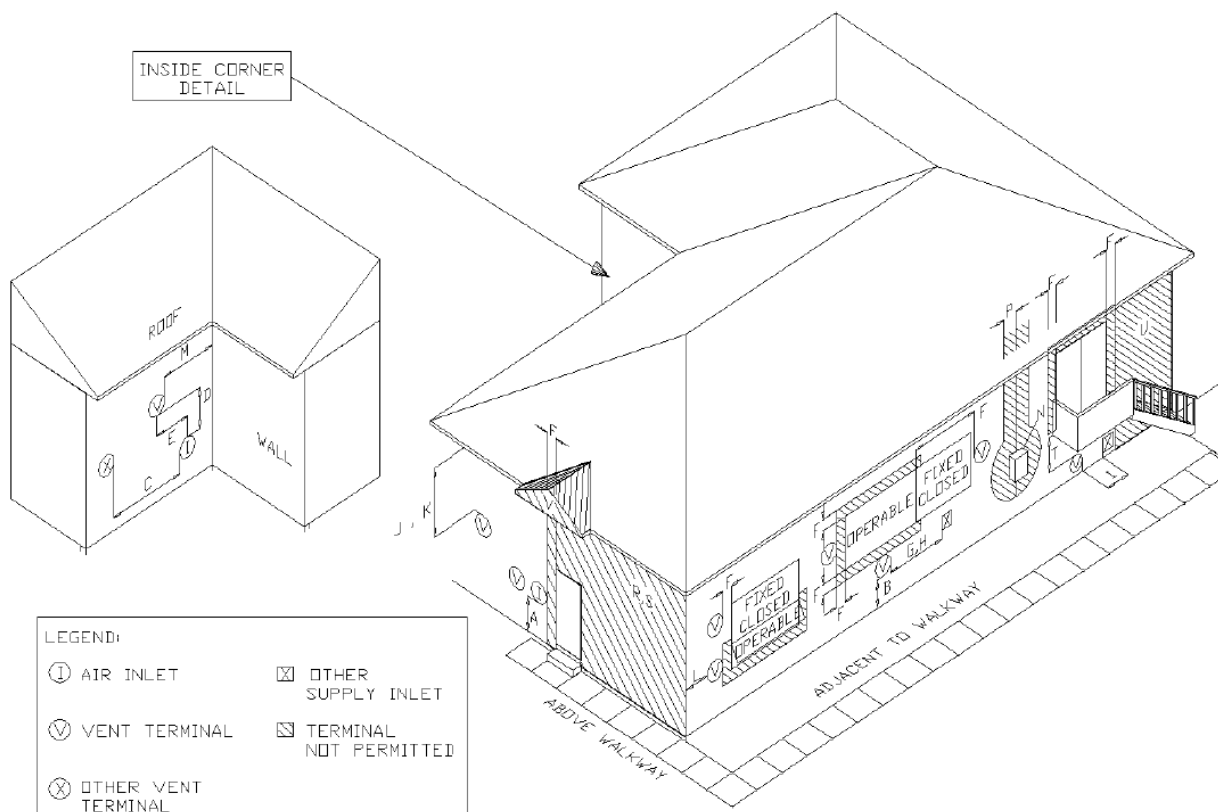

### **Flammable Solvents and Plastic Piping**

Due to the extremely flammable characteristics of most glues, cements, solvents, and primers used in the process of joining plastic vents and air-inlet pipes explosive solvent vapors must be evacuated from the vent and air-intake prior to start-up. Avoid using excess cement or primer that may lead to pooling inside the pipe assembly. Fresh assembled piping assembly should be allowed to cure for a minimum of 8 hours before applying power to the gas fired appliance. Refer to Mandatory Pre-commissioning Procedure for Plastic Venting in this section.

**DANGER:** Flammable Cements and Primers – It is the installers’ responsibility to familiarize themselves with the hazard associated with explosive solvents and to take all precautions to reduce these risks. Failure to follow these instructions can cause explosions, property damage, injury, or death.

### **Mandatory Pre-commissioning Procedure for Plastic Venting (PVC or CPVC)**

**WARNING:** Do not apply power to the water heater prior to step 4 in the Mandatory Pre-commissioning Procedure for Plastic Venting.

**WARNING:** Spark Igniter Cable – Maintaining a minimum 2 inch separation between spark igniter circuit and conductors. Failure to follow instructions may result in component failure, injury, or death.

1. Working with the power turned off to the water heater, completely install the vent and air-inlet system, securely cementing joints together. If possible, allow primers/cements to cure for 8 hours before firing the burner. If curing time is less than 8 hours, proceed with the following steps.

2. Maintain the water heater gas supply shut-off valve in the off position.
3. Disconnect both electrical leads going to the spark igniter. Refer to the warning regarding Spark Igniter Cable.
4. Turn power on to the water heater and apply a heat demand.
5. Allow for 3 complete trials for ignition, consisting of pre and post purge of the combustion blower, until an ignition lockout occurs. Repeat this process two more times (i.e. 9 complete ignition sequences in total).
6. Turn power off and reconnect the electrical leads to the igniter.

## Condensate Drain

This unit produces liquid condensate in the heat exchanger and venting system as a product of combustion. Steps must be taken to ensure that condensate does not collect in the venting system; therefore, all exhaust piping must slope back to the water heater a minimum ¼” per linear foot of vent. Condensate must be drained from the unit into a household drain. Check with your municipality or local gas company to determine if the disposal of combustion condensate is permitted in your area (e.g. in the State of Massachusetts the condensate must be neutralized prior to entering a drain.)

Figure 12 - Condensate Outlet Location

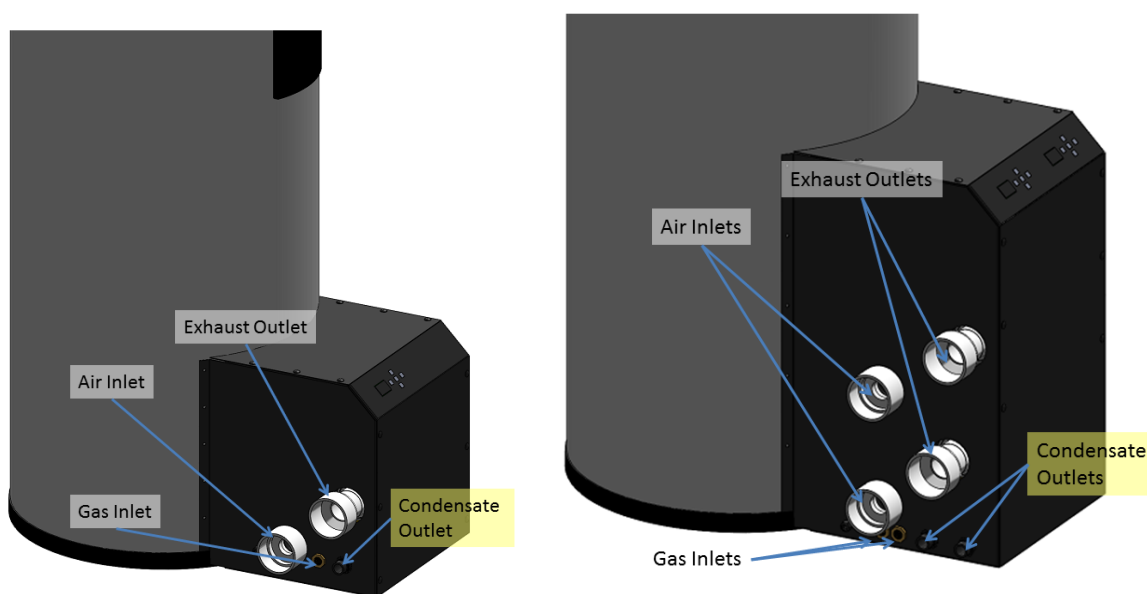

Single Unit Heater on Left, Double Unit Heater on Right

The following are important notes that must be taken into consideration when constructing the condensate drain system:

- **DO NOT** install condensate lines outside, as this could lead to a frozen or blocked drain. A frozen or blocked drain will cause the condensate to fill the combustion chamber. This will result in no heat as the unit will shut down, and damage to the flame sensor and components can occur.
- **NEVER** use copper, steel, or galvanized piping in the construction of the condensate disposal system as condensate is very corrosive and will corrode most metallic drains and sewer pipes.
- When a condensate pump is used or required, select a pump that is designed for residential furnaces.

**WARNING:** If the combustion chamber has been flooded due to the condensate drain backing up, or for any other reason, the combustion chamber door must be removed and the inside of the water heater must be inspected for component damage. Failure to follow these instructions may result in fire, property damage, serious injury, or death.

## Gas Installation

**WARNING:** This device is factory equipped to operate with natural gas. If propane gas is to be used with this device, the installation of a conversion kit is required prior to operation.

**Figure 13 - Gas Inlet Location**

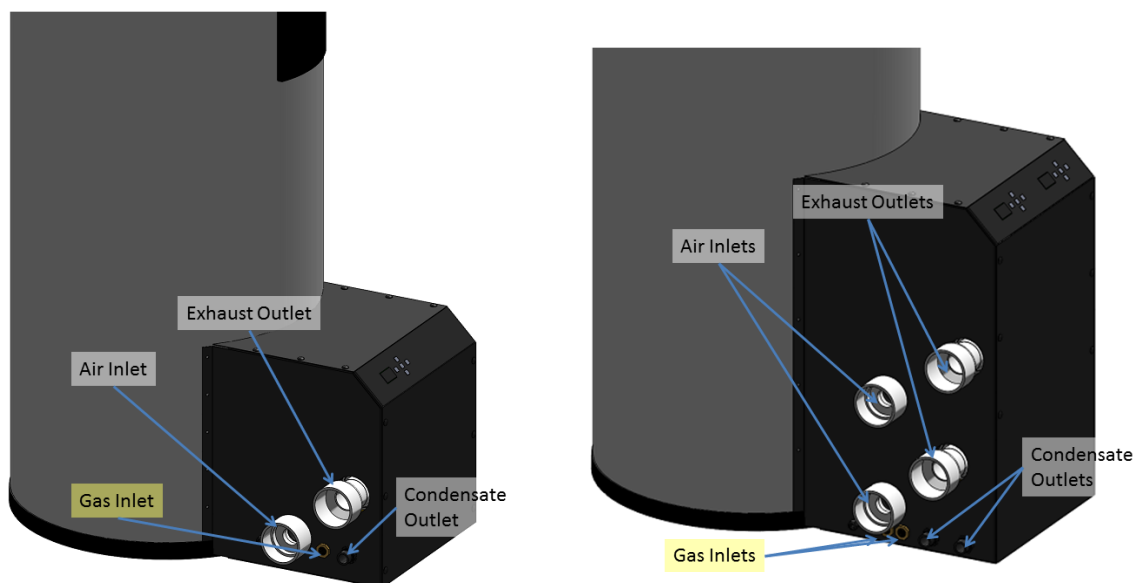

Single Unit Heater on Left, Double Unit Heater on Right

Refer to the current **National Fuel Gas Code ANSI Z223.1/NFPA 54 or CAN/CGA B149.1** installation codes and local codes for gas piping requirements and sizing. Pipe size running to the unit depends on:

- Length of pipe
- Number of fittings
- Type of gas
- Maximum input requirement of all gas appliances

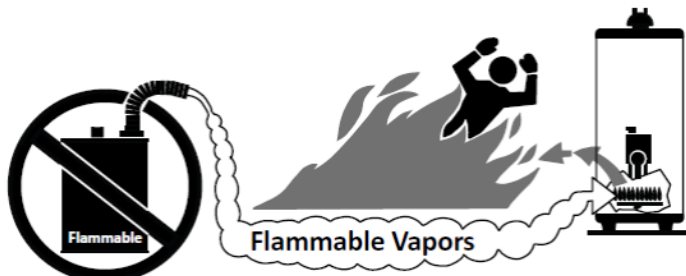
| <b>! DANGER</b>  |  |
|--|--|
|    |  |
| <p><b>!</b> Vapors from flammable liquids will explode and catch fire causing death or severe burns.</p> <p>Do not use or store flammable products such as gasoline, solvents or adhesives in the same room or area near water heater.</p> | <p>Keep flammable products:</p> <ol style="list-style-type: none"> <li>1. far away from heaters</li> <li>2. in approved containers</li> <li>3. tightly closed and</li> <li>4. out of children's reach.</li> </ol> <p>Vapors:</p> <ol style="list-style-type: none"> <li>1. cannot be seen,</li> <li>2. are heavier than air,</li> <li>3. go a long way on the floor and</li> <li>4. can be carried from other rooms to the pilot flame by air currents.</li> </ol> |
| <p><b>Installation:</b><br/>Do not install water heater where flammable products will be stored or used unless the main burner and pilot flame are at least</p>  | <p>18 in (457 mm) above the floor. This will reduce, but not eliminate, the risk of vapors being ignited by the main burner or pilot flame.</p>  |
| <p>Read and follow water heater warnings and instructions.<br/>If owner's manual is missing, contact the retailer or manufacturer.</p>   |  |

Ensure that:

- The gas line connection to the water heater does not apply any weight to the gas valve. Hubbell recommends using approved flexible gas piping (if acceptable by local codes) to connect the water heater to the gas supply.
- You plan the installation so that the piping does not interfere with the vent pipe, or the removal of the valve, burner, and serviceable components.
- The water heater shall be installed such that the gas ignition system components are protected from water (dripping, spraying, rain, etc.) during installation and servicing.
- The gas piping is large enough for all the appliances. No appreciable drop in line pressure should occur when any unit (or combination of units) lights or runs. Use common gas-line size practices.
- Always use a pipe-threading compound that is recommended for natural gas. Apply sparingly to all male threads, starting at two threads from the end. Over doping or applying dope to the female end can result in a blocked gas line.
- **DO NOT TIGHTEN FITTING WITHOUT SUPPORTING THE GAS VALVE** as damage to the gas valve or combustion blower can occur.
- Install a manual "equipment shut-off valve" that is listed by a nationally-recognized testing lab.
- The gas line piping can safely be removed from the water heater for servicing by strategically placing the gas line shutoff and union.

- All gas piping, including gas components in the water heater, are checked for leaks using a “bubble test” prior to operating the water heater.

**WARNING:**

- Strain on the gas valve and fittings may result in vibration, premature component failure and leakage and may result in a fire, explosion, property damage, serious injury, or death.
- Flexible gas piping cannot be used within the water heater cabinet and cannot pass through the cabinet wall, so rigid piping must be used. Failure to follow these instructions may result in fire, property damage, serious injury, or death.
- Do not use an open flame to test for gas leaks. Failure to follow these instructions may result in fire, property damage, serious injury, or death.
- When performing a pressure test on the gas line piping, be sure the water heater is disconnected or isolated if the test pressure is expected to exceed ½ PSI (14”w.c.), as damage to the valve could occur resulting in fire, property damage, serious injury, or death.

**Gas Valve and Burner Set-up**

**WARNING:** The gas valve must be set up by a licensed gas technician. Improper setup may result in incorrect operation, damage to components or property, injury, or death.

**Figure 14 – Multiventuri Operating Principle**

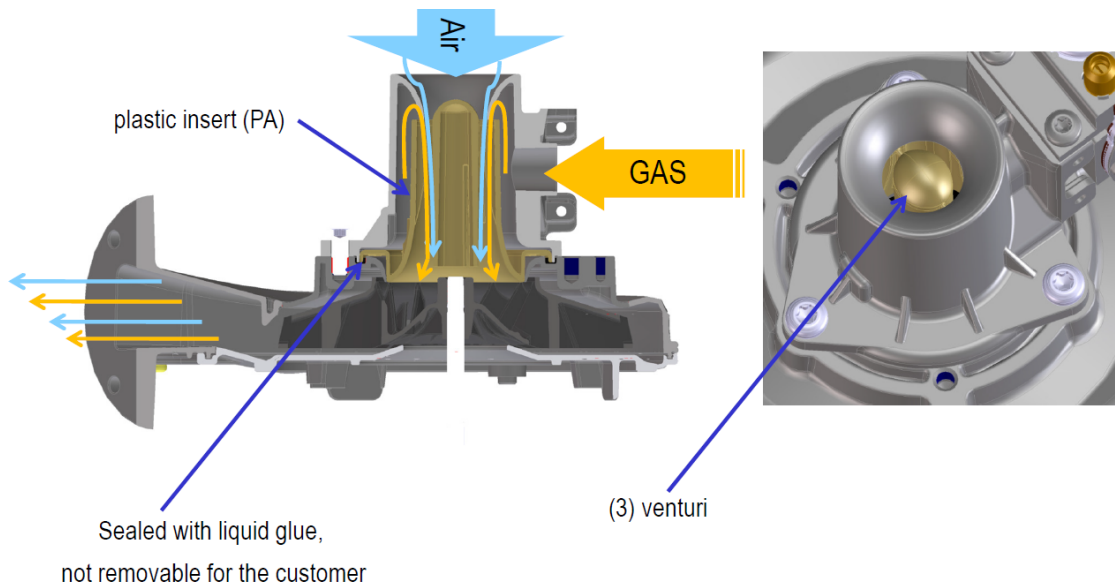

**Figure 15 – Gas Valve Operating Principle**

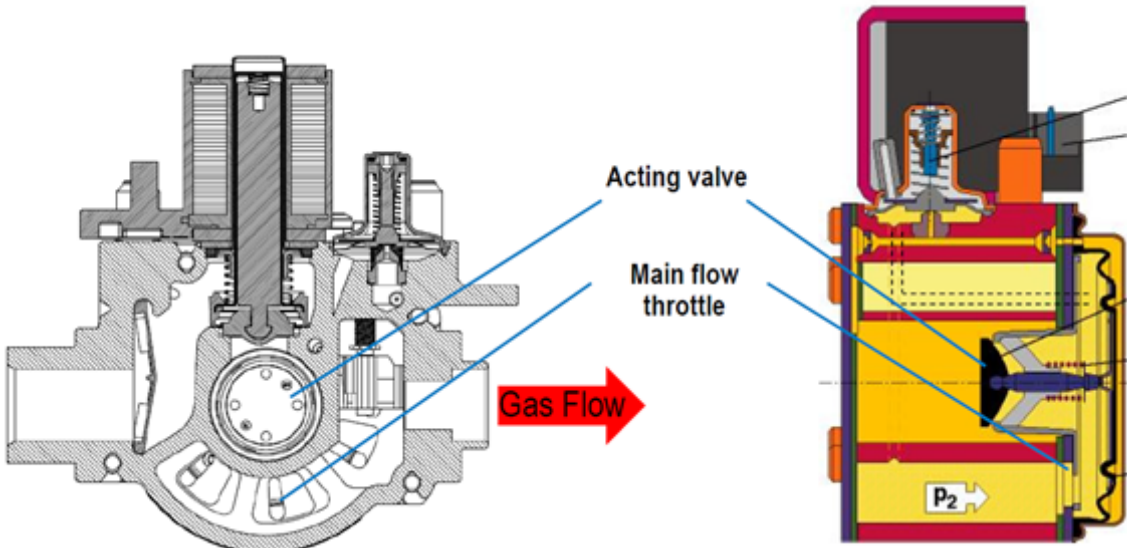

Figure 16 – Gas Valve Diagram

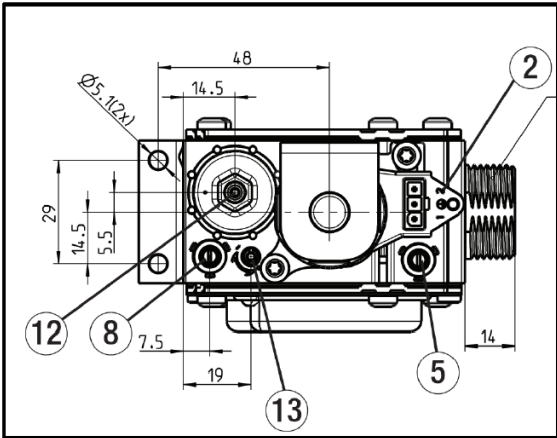

Table 7 - Gas Unit Values

| Gas Type    | Line Pressure (inches W.C.) |     |      | CO2 (%)            |                    | CO (ppm)<br>Max |
|-------------|-----------------------------|-----|------|--------------------|--------------------|-----------------|
|             | Nominal                     | Min | Max  | Min (3000 Fan RPM) | Max (7500 Fan RPM) |                 |
| Natural Gas | 7.0                         | 3.5 | 10.5 | 9.0%               | 9.5%               | 175             |

**Gas Line Pressure**

The water heater gas valve is equipped with a line pressure test port. Use the following procedure to measure the gas line pressure to the water heater to ensure it falls within the range given in Table 7 - Gas Unit Values.

**NOTICE:** The inlet gas pressure must not exceed 10.5” H20.

1. Turn the supply of gas to the water heater off.
2. Open the bleed screw of the line pressure test port (item 8 in Figure 16 – Gas Valve Diagram) approximately 1-1/2 turns. This port is directly connected to the gas line feeding the water heater.

3. Force ¼” ID tubing over the housing of the line pressure test port; install the other end of the tubing to an appropriate line pressure test gauge or manometer. Ensure both ends of the tubing make a tight connection.
4. Open the supply of gas to the water heater and check for gas leaks.
5. Observe the line pressure under static conditions and compare it with the table above. The pressure will be greatest under static conditions.
6. With all other gas appliances running, operate the burner to the maximum firing rate and compare it to the table above. The pressure will be lowest during maximum flow of gas.
7. Adjust the gas line pressure to ensure the parameters in the table above are attained under all conditions. If possible adjust the line pressure to the “Nominal/Desired” value listed in the table above while the unit is operating at the maximum modulation rate.
8. Continue observing the gas line pressure until the completion of the combustion analyses in case adjustments need to be made.
9. Upon the completion of the line pressure testing, return the bleed screw of the line pressure test port to the closed position.

**NOTICE:** The line pressure is a function of the gas supply and is affected solely by field provided parameters such as line size and regulator settings. Under no circumstances can the water heater gas valve influence or be used to adjust the gas line pressure.

**DANGER:** Failure to close the bleed screw of the line pressure test port will cause a severe leakage of gas, resulting in a fire or explosion causing property damage, serious injury, or death.

### Gas Valve Calibration and Flue Analysis Procedure

**WARNING:** Failure to perform the flue gas analysis and adjustment detailed in this section may result in erratic and unreliable burner operation, leading to reduced efficiency, increased fuel consumption, reduced component life, heat exchanger combustion deposits, and general unsafe operation. Failure to follow these instructions may result in serious injury or death.

Figure 17 – Gas Valve Schematic

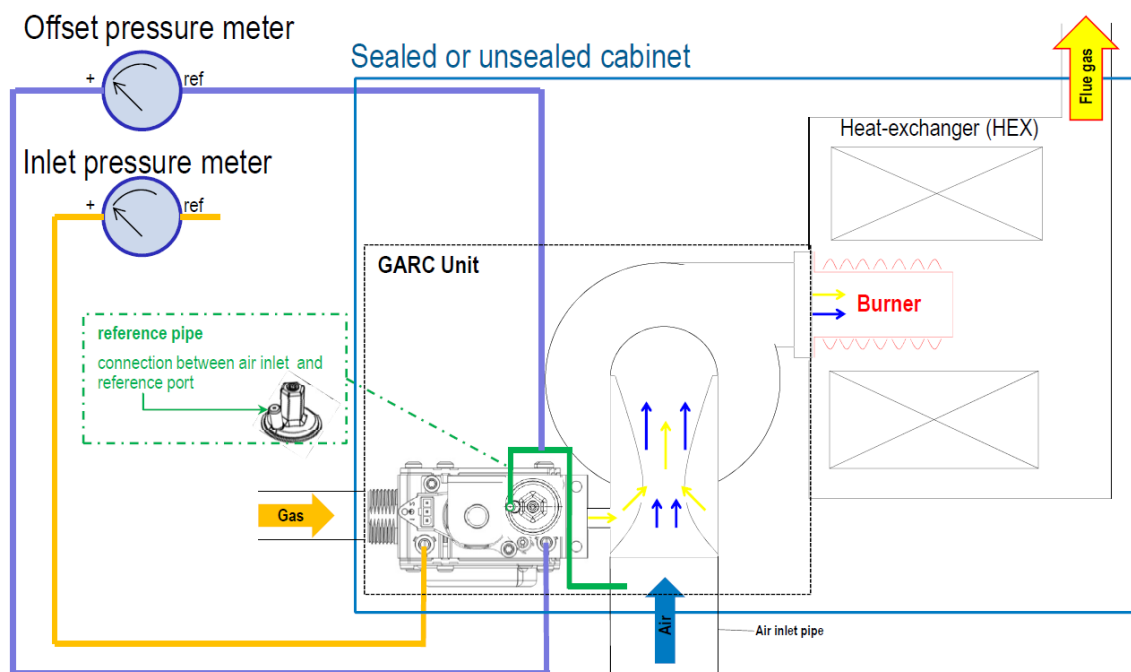

Figure 18 – Gas Valve Calibration

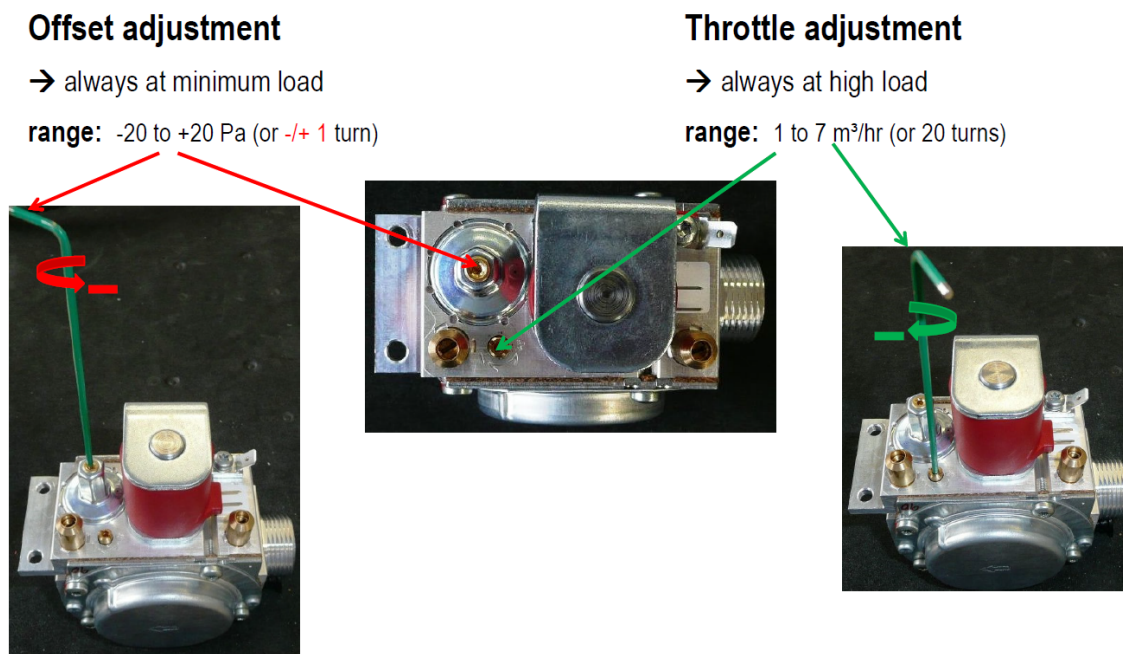

Figure 19 – Test Port Location

1. Read all safety instructions carefully.
2. Assemble and setup the appliance so that it is operational.
3. Connect all the proper combustion analysis equipment and insert combustion analyzer into ventilation.
4. Run boiler at maximum speed (see Installer Menu).
5. Adjust gas flow until optimum CO<sub>2</sub> level at maximum speed is achieved by turning throttle adjustment screw (item 13 in Figure 16 – Gas Valve Diagram) clockwise to obtain lower CO<sub>2</sub> or counterclockwise to obtain higher CO<sub>2</sub>.
6. Run boiler at minimum speed (see Installer Menu).
7. Adjust gas flow until optimum CO<sub>2</sub> level at minimum speed is achieved by offset adjustment screw (item 12 in Figure 16 – Gas Valve Diagram) clockwise to obtain higher CO<sub>2</sub> or counterclockwise to obtain lower CO<sub>2</sub>.
8. Run boiler at maximum speed again and check CO<sub>2</sub> level.
9. If CO<sub>2</sub> level is ok skip next step.
10. If CO<sub>2</sub> level is not ok, repeat steps 5-9.

**NOTE:** If you are installing a Dual Heat Exchanger unit, repeat all steps above exactly the same for the second unit. These two units operate separately, and it is essential to make sure both sets of exchangers have been set up properly.

## Water Piping Installation

1. Connect the cold water inlet and hot water outlet to the appropriate connections as shown; refer to the drawing for location and sizes.
2. Install the combination temperature and pressure safety relief valve in the tapping provided. Note that this is required by law for safety considerations.

3. Install a relief valve overflow pipe to a nearby floor drain.
4. When the system requires water for space heating at temperatures higher than required for other uses, a means such as a mixing valve shall be installed to temper the water for those uses in order to reduce scald hazard potential. (See Figure 21 – Mixing Valve Water Piping Installation Diagram)

**CAUTION:** No valve of any type should be installed between the relief valve and tank or in the drain line.

**NOTICE:** The designed water supply temperature is to be below 160°F.

**NOTICE:** The water heater that will be used to supply potable water shall not be connected to any heating system or component(s) previously used with a non-potable water heating appliance.

## Space Heating Application

1. Water heaters for combination water/space heating shall not be used space-heating-only applications.
2. All piping and components connected to the water heater for the space heating application shall be suitable for use with potable water.
3. Toxic chemicals, such as used for boiler treatment, shall not be introduced into the potable water used for space heating.
4. To install piping for the space heating application, attach the space heating return and space heating supply to the coil in the top of the tank.

**Figure 20 – Water Piping Installation Diagram**

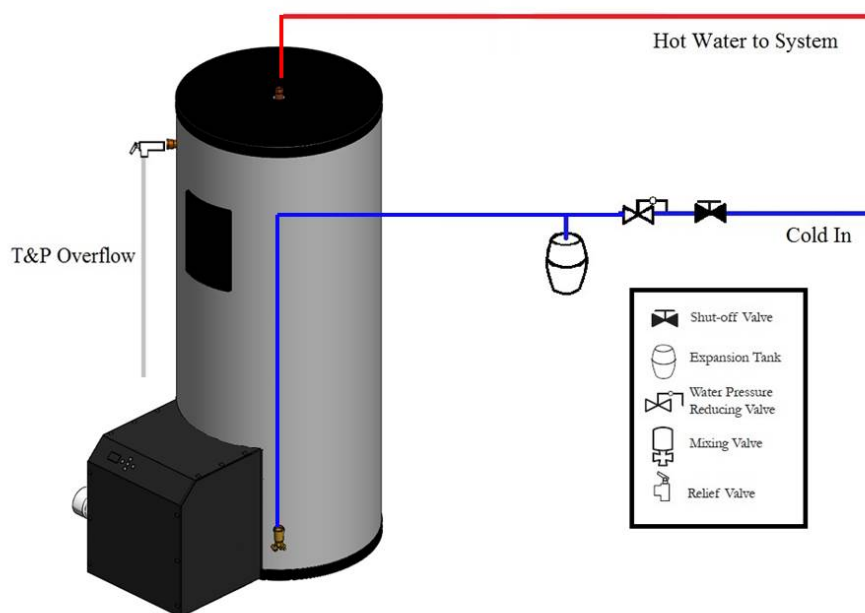
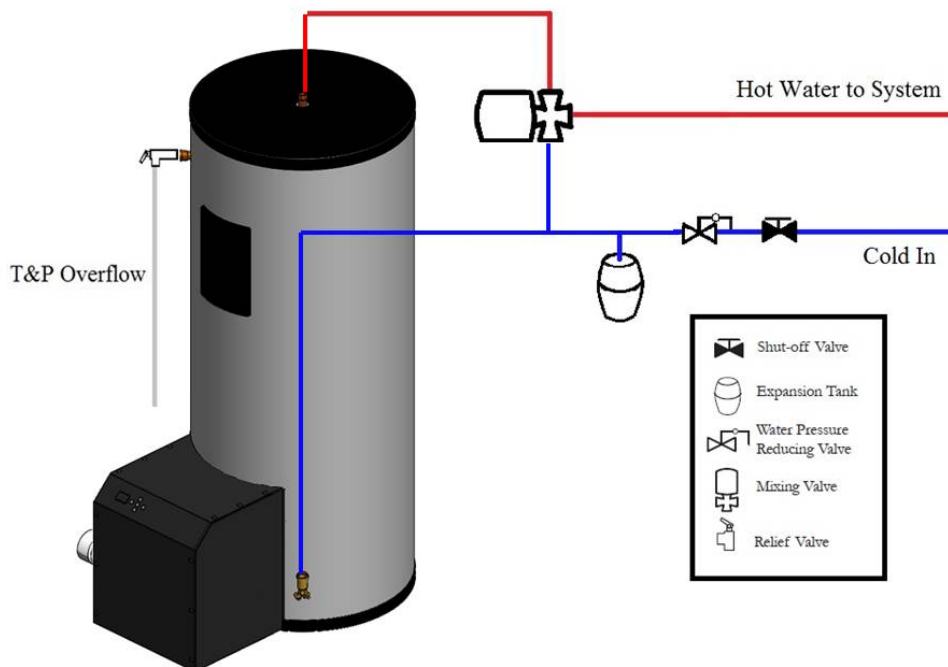

Figure 21 – Mixing Valve Water Piping Installation Diagram



### Filling the Water Heater

1. Completely close the drain valve.
2. Open the highest hot water faucet to allow all air to escape from piping.
3. Open the valve to the cold water inlet and allow the heater and piping system to completely fill, as indicated by a steady flow of water from the open faucet.
4. Close the faucets.

### **Electrical Installation**

1. Power cord should be plugged directly into a proper 120V wall outlet. Power strips and extension cords should not be used.
2. If equipped with elements, enter junction box with properly sized feeder leads. Note that overcurrent circuit protection is required. For the standard model the overcurrent protection must be rated 25 amp minimum.
3. Connect these power leads to wires enclosed in junction box with wire nuts.
4. All other electrical connections are made at the factory; therefore, no other electrical connections are necessary.

**CAUTION:** Label all wires prior to disconnection when servicing controls. Wiring errors can cause improper and dangerous operation. Verify proper operation after servicing.

### **Final Checks**

1. Check all connections for tightness.
2. Check for gas and water leaks.

3. Ensure that all the above steps are completed.

## Lighting the Water Heater

**DANGER:** Before Start-up refer to Mandatory Pre-commissioning Procedure for Plastic Venting in section Mandatory Pre-commissioning Procedure for Plastic Venting (PVC or CPVC). Failure to follow these instructions can result in explosion, injury, or death.

**DANGER:** Prior to turning the gas supply on and lighting the water heater, ensure all aspects of installation are complete and in conformance with the instructions provided in this manual, including the Vent/Air-intake, Condensate Drain, and System Water Piping. Failure to precisely follow these instructions will cause fire or explosion resulting in property damage, serious injury, or death.

**WARNING:** Should overheating occur or the gas supply fails to shut off, turn off the manual gas control valve to the water heater. Failure to follow instructions could result in explosion, causing property damage, serious injury, or death.

Before lighting the heater at any point, ensure the following:

- The water heater is wired, and plumbed in accordance with this manual.
- The gas shut-off valve is turned on, and the gas system has been fully tested for leaks.
- The system is completely filled with water, and that ALL the air is purged out, and has been fully tested for leaks.

**WARNING:** The initial lighting of the water heater must be performed by a licensed Gas Technician. Failure to follow instructions may result in property damage, serious injury, or death.

**DANGER:** Allow primers/cements to cure for 8 hours prior to start-up. If curing time is less than 8 hours, first perform steps 2 through 6 of section Mandatory Pre-commissioning Procedure for Plastic Venting (PVC or CPVC). Failure to follow these instructions can result in explosion, serious injury, or death.

**NOTICE:** Should overheating occur or the gas supply fails to shut off, turn off the manual gas control valve to the appliance.

### **Initial Start-Up**

1. Insert 120V plug into outlet to power on gas unit. The water heater should run through a purge, and combustion should occur. The control system has a built in ignition retry, allowing the system to try at least three times before locking out.
2. With the unit operating at full capacity, verify that the gas line pressure is 3.5-13.5 inches W.C. (.125-.5 psi) for natural gas.
3. Using an appropriate oxygen or carbon dioxide analyzer, take a sample of the flue gas. The sample must fall within the acceptable ranges for carbon dioxide, which is 9.0% at low fire, and 9.5% at high fire, for natural gas.  
Perform at least three lights in succession to ensure proper operation.
4. After the three successive lights, switch gas inlet off, and allow the unit to cycle again. Ensure that it tries to light three times and then shuts off.

**NOTE:** For the Dual Heat Exchanger unit, these steps should be repeated for the second heat exchanger after testing the first using these steps; as each heat exchanger operates separately.

**WARNING:** If the unit fails to light consistently and smoothly, contact Hubbell for technical assistance at 1-203-378-2659. Never allow the water heater to operate if the ignition or operation of the burner is rough or erratic. Failure to follow these instructions may result in serious injury or death.

### **Turning Off the Water Heater**

1. Set the thermostat to the lowest setting and then turn off all power to the water heater.
2. Turn the gas shut-off valve to the off position.

### **Turning On the Water Heater**

1. Stop and read these instructions very carefully.
2. This water heater does not have a pilot. It is equipped with an ignition device that automatically lights the burner. Do not try to light the burner by hand.
3. Turn the gas shut-off valve to the off position and then remove the front cover.
4. Wait five minutes to clear out any gas. Then check for gas, including near the floor. If you smell gas, STOP and see the directions in the front of this manual. If you do not detect any gas, proceed.
5. Turn the gas shut-off valve to the on position, wait an additional five minutes, and check for gas.
6. Replace the front cover.
7. Set the thermostat to the desired setting, and then turn on all power to the water heater.
8. The ignition sequence is automatic and combustion will occur after a brief fan purge. Ignition will retry 3 times.
9. If ignition does not occur, turn off the gas and electricity to the water heater and contact a professional service technician or gas supplier.
10. After the water is heated for the first time, monitor the water temperature as described in the Scheduled Maintenance section.

## **3.0 CONTROLLER OPERATION**

### **LCD Display**

The display module contains 13 symbols and three 7-segment blocks (with a minus-sign and a dot, as shown in the figure 1).

Figure 22 - LCD Symbols



The table below describes the function per symbol.

**Table 8 - Status Symbols and Their Meanings**

| 900DI Status Overview |  |
|-----------------------|--|
| Status Symbol         | Description  |
|                       | (---) Connecting display with controller and start communication   |
|                       | (ini) Initializing software  |
|                       | (rdy) Standby  |
|                       | Preheat Domestic Hot Water.  |
|                       | Domestic Hot Water demand:<br>the temperature display shows the actual flow temperature  |
|                       | Indicates the appliance burner is ON   |
|                       | Alarm condition*: the alarm code is displayed (blinking) on the temp. display:<br>A xx = Lockout error number; E xx = Blocking error number                  |
|                       | Demand for frost protect is active:<br>the temperature display shows the actual flow temperature   |
| °C                    | Temperature in °Celsius, this value is displayed with a comma (e.g. 20,5 °C).<br>If the value of the temp. is set to °F, the °C- icon will <u>not</u> show . |
|                       | Located on top and bottom corner on the left side of the screen.<br>This symbol is shown when scrolling through the User menu.                               |
|                       | Located on the top and bottom corner on the right side of the screen.<br>Indicates when the up/down buttons should be used to set a parameter.               |

**Button Layout**

5 different buttons are present on the 900DI LCD Display for operating the module, which are positioned the right side of the display. Figure 2 shows the location of the buttons.

**Figure 23 - Lay-out with Push Buttons**

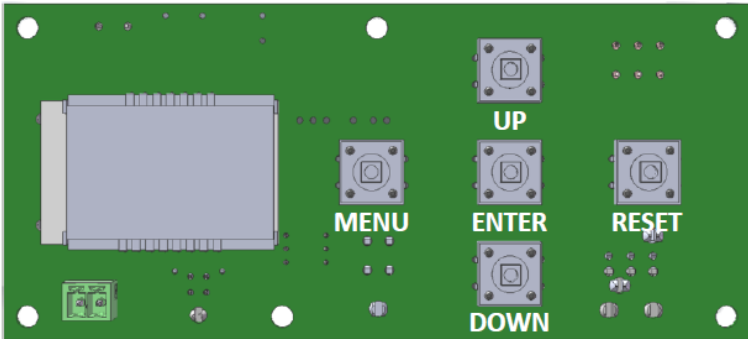

The table below describes the button functions.

**Table 9 - Button Functions**



| 900DI – Button description |   |
|----------------------------|---|
| Button                     | Function  |
| MENU                       | Press to enter the User menu <i>or</i> press for 10 sec. to enter the Installer menu                    |
| ENTER                      | Press to confirm when you have selected a parameter <i>or</i> press to confirm an altered setting       |
| RESET                      | Press to reset the appliance in case of a Lock-out error <i>or</i> press to cancel an altered parameter |
| UP                         | Scroll up <i>or</i> increase the value (of a parameter)   |
| DOWN                       | Scroll down <i>or</i> lower the value (of a parameter)  |

## Temperature Adjustments via Status Overview

Set DHW set point directly via status overview

The DHW set point can be directly adjusted in the Status overview. In that case, the following icons are shown, including the set point temperature that is being altered.

**Table 10 - Important Icon Descriptions**

| User menu  |  | Description   |
|--|--|---|
| Icons shown  |  |   |
|  |  | DHW Setpoint, can be altered by using the [UP] and [DOWN] buttons |

When the DHW set point is being directly adjusted via the Status overview and is set below *DHW\_Setpoint\_Min*, the display will show “OFF” (blinking). This means that the appliance is OFF and will not respond to any DHW demand anymore (and that you cannot lower the value any further).

**DANGER:** When altering the set temperature of the appliance:



- Water temperature over 125°F can cause severe burns instantly or death from scalds.
- Children, disabled and elderly are at the highest risk of being scalded.
- See instruction manual before setting temperature at the water heater.
- Feel water before bathing or showering.
- Temperature limiting valves are available, see manual.

The temperature of the water in the heater is regulated by an adjustable, automatic, temperature control which uses surface mounted thermistors located behind the jacket access panels. These automatic controls are set at the factory to maintain a water temperature of 120°F. Although these controls are designed to industry standards, they can fail to control temperature properly without any notice, and therefore should be tested periodically for your protection.

To perform the test: Turn on the hot water faucet and measure the maximum temperature with an accurate thermometer. If the temperature is above the safe limits for your circumstances call a service technician to adjust or replace the control.

**DANGER: IF YOU DISCOVER EXTREME HOT WATER COMING FROM THE FAUCET, IMMEDIATELY SHUT OFF THE ELECTRICITY AND GAS AT THE MAIN SWITCH AND CALL COMPETENT SERVICE PERSONNEL. ANY OVERHEATED WATER HEATER IS A POTENTIAL HAZARD TO LIFE AND PROPERTY. DO NOT OPERATE UNTIL THE SOURCE OF THE PROBLEM HAS BEEN DETERMINED AND ELIMINATED.**

## Showing Errors on the Status Overview

In case of a Warning or Error/Alarm condition, the Blocking ('E'), Locking ('A'), or Attenuations ('n') error number will be constantly displayed on screen (blinking). The User menu will be inaccessible at this time. When this situation occurs, the Locking error (L) can be reset by pressing [RESET].

**If any errors appear on your controller during operation, reference the error messages section of Troubleshooting or call a qualified technician to examine your water heater.**

## User Menu

Enter the User view menu by pressing the [MENU] button once. This menu can be used to look at the values of a selection of parameters (read-only) or to view the sensor temperatures. The table below shows how to enter/operate the User menu in some simple steps:

**Table 11 - User Menu Guide**

| 1. Enter the User menu     | 2. Scroll through parameter list                                    | 3. Select parameter  | 4. Alter value of parameter  | 5. Confirm/cancel alteration  |
|----------------------------|---|--|--|---|
| - Press [MENU] button once | - Scroll through the parameter list with the [UP] / [DOWN] buttons* | - Select a parameter to alter/read-out its value by pressing [ENTER]** | - Alter a value of the parameter with the [UP] / [DOWN] buttons. When the parameter is being altered, the value on the display will blink. | - Confirm (save) with [ENTER] or<br>- Cancel with [RESET]             |
|                            | - 10 sec. of no action: automatically return to the Status overview | - 10 sec. of no action: automatically return to the Status overview    |  | After saving/cancelling you automatically return to the User menu (1) |

\* If these buttons are no longer operated for 2 sec. the parameter no. and the current value displayed will show with intervals of 2 sec.

\*\* In case of a read-only parameter, the current value will be displayed continuously.

The following table describes the parameters in the User menu, which are all read-only:

**Table 12 - Parameter List and Descriptions**

| 900DI User menu – Parameter list |  |  |
|----------------------------------|--|--|
| Parameter                        | Description                              | Value  |
| 100                              | Sensor 1                                 | °C or °F   |
| 101                              | Sensor 2                                 | °C or °F   |
| 102                              | Sensor 3                                 | °C or °F   |
| 103                              | Sensor 4                                 | °C or °F   |
| 108                              | Ionization current                       | µA   |
| 111                              | DHW pump status                          | ON or OFF  |
| 140                              | Actual fan speed                         | x 10 RPM <sup>1</sup>  |
| 141                              | Ignition fan speed                       | x 10 RPM <sup>1</sup>  |
| 142                              | Min. fan speed                           | x 10 RPM <sup>1</sup>  |
| 143                              | Max. fan speed                           | x 10 RPM <sup>1</sup>  |
| 151                              | Last Lockout error                       |  |
| 152                              | Last Blocking error                      |  |
| 153                              | Number of flame failures                 |  |
| 154                              | Number of successful ignitions           | x 100 <sup>2</sup>   |
| 155                              | Number of failed ignitions               |  |
| 157                              | Total hours of operation for DHW         | x 10 hours <sup>3</sup>  |
| 158                              | Total days of operation of the appliance | x 10 days <sup>4</sup>   |
| 159                              | Interval between Lockout errors          | "00"- "59" = 0-59 minutes<br>"01h"- "23h" = 1-23 hours<br>"01d"- "06d" = 1-6 days<br>"01u"- "63u" = 1-63 weeks |
| 160                              | Interval between Blocking errors         | "00"- "59" = 0-59 minutes<br>"01h"- "23h" = 1-23 hours<br>"01d"- "06d" = 1-6 days<br>"01u"- "63u" = 1-63 weeks |

<sup>1</sup> The value of these parameters is given in RPM. Because the display can only show 3 digits, the number on the screen has to be multiplied times 10. For example, when the display shows the number 20, it means that RPM is 20x10, i.e. RPM is 200.

<sup>2</sup> The value of this parameter is given with a factor of x 100. For example when displaying 001 this means 100 successful ignitions.

<sup>3</sup> The value of this parameter is the number of hours x 10. For example, if the number on the display says 50, it means 50x10, which is 500 hours.

<sup>4</sup> The value of this parameter is the number of days x 10. For example, if the number on the display says 36, it means 36x10, which is 360 days.

## Installer Menu

The table below schematically shows how to enter/operate the Installer menu in some simple steps:

**Table 13 - Installer Menu Guide**

| 1. Enter the Installer menu     | 2. Scroll through parameter list                                    | 3. Select parameter  | 4. Alter value of parameter  | 5. Confirm/cancel alteration   |
|---------------------------------|---|--|--|--|
| - Hold [MENU] button for 5 sec. | - Scroll through the Parameter list with the [UP] / [DOWN] buttons* | - Select a parameter to alter/read-out its value by pressing [ENTER]** | - Alter a value of the parameter with the [UP] / [DOWN] buttons. When the parameter is being altered, the value on the display will blink. | - Confirm (save) with [ENTER] or<br>- Cancel with [RESET]                  |
|                                 | - 10 sec. of no action: automatically return to the Status overview | - 10 sec. of no action: automatically return to the Status overview    |  | After saving/cancelling you automatically return to the Installer menu (1) |

\* If these buttons are no longer operated for 2 sec. the parameter number and the current value displayed will show with intervals of 2 sec.

\*\* In case of a non-adjustable parameter, the current value will be displayed continuously.

The following table shows the available parameters in the Installer menu.

**Table 14 - Installer Menu Parameter List**

| 900DI Installer menu – Parameter list |   |   |
|---------------------------------------|---|---|
| Parameter no.                         | Description   | Value   |
| 207                                   | Setpoint  | Min. 39°C – Max. 70°C. This value is not fixed, but saved in the internal memory. The user can change this value in the Installer menu. |
| 208                                   | Enable DHW  | Turns 'on' or 'OFF' the DHW functionality   |
| 210                                   | System test power   | OFF, FAn, LOu, Ign, Hig, rEg  |
| 214                                   | Display test (press [UP] and all icons and leds will light-up). Press [RESET] to go back in the Installer menu. |   |
| 260                                   | DHW minimal Power   | 1 - 50%   |
| 261                                   | DHW maximum Power   | 1 - 100%  |
| 280                                   | Service Reminder. Status jumps back.  | not implemented   |
| 281                                   | Service Reminder setting.   | not implemented   |

\* When this parameter is being used you will see the letters 'TST' blink (Test).

## Warnings

**Table 15 - Descriptions of Errors**

| Display 'Err' | Error                   | Int nr. | Description   |
|---------------|-------------------------|---------|---|
| 200           | FILL_WARNING            | 200     | Pressure is too low, demand has stopped, but no error needed to be stored at this time  |
| 201           | FLUE_BLOCKED            | 201     | Flue is blocked, demand needs to be stopped with fan at ignition speed*, but no error needed to be stored at this time                  |
| 202           | LOWFLOW_PROTECTION      | 202     | Flow is too low, demand needs to be stopped with fan at ignition speed*, but no error needed to be stored at this time                  |
| 203           | HEATEXCHANGE_PROTECTION | 203     | Heat Exchange Protection active because there's a too high difference in temperature between Supply and Return Heat Exchange Protection |

\* Ignition speed is the same as Pre Purge Speed and Post Purge speed.

**If any errors appear on your controller during operation, reference the error messages section of Troubleshooting or call a qualified technician to examine your water heater.**



## 4.0 SCHEDULED MAINTENANCE

### WARNING / CAUTION

Before performing any maintenance procedure, make certain the power supply is OFF and cannot accidentally be turned on.

### Freezing

The tank should be fully drained in the event the electricity has been turned off and if there is danger of freezing.

### Manual Inspection

1. Monitor temperature as follows:
  - a. Let water heater completely heat to the designated set point.
  - b. When heated (that is, when unit stops running).
  - c. Compare water temperature of drawn water to the temperature set point of the controller. Normal variation between the two points is approximately  $\pm 5^{\circ}\text{F}$ .
  - d. If the two readings do not coincide within acceptable tolerances and verification has been made of the accuracy of the temperature-reading gauge, replace the controller.
2. Lift test lever on relief valve and let water run through valve for a period of approximately 10 seconds. This will help flush away any sediment that might build up in water passageways.
3. Inspect heat exchanger and flange for leakage as follows:
  - a. Shut off power supply, gas supply, and remove housing cover.
  - b. Visually inspect for evidence of leakage.
4. Check that the tank lights smoothly and consistently, that the combustion fan is noise and vibration free, and that condensate is able to exit the unit freely and no sediment has built up within.
  - a. Clean the burner of any residue to prevent any unwanted objects from ending up in the burner.
  - b. If the unit does not run smoothly, turn off the power and gas, and call a qualified licensed technician.
5. Inspect ventilation to be sure that there is no obstruction, leak, or damage that would cause a backup or leak of gas.
6. Check for loose electrical connections. Tighten as necessary.
7. Flush tank as follows
  - a. Shut off power supply and gas supply.
  - b. Close valve on cold water inlet piping.
  - c. Open valve on drain piping.
  - d. Open hot out fixture to let in air.
  - e. Allow tank to empty.
  - f. Close drain valve.
  - g. Open cold water valve.
  - h. Fill tank until water comes out of hot out fixture, and keep open until there is no more air coming out.
  - i. Close hot out fixture.
  - j. Turn power supply and gas ON.

## 5.0 TROUBLESHOOTING

**Table 16 - Troubleshooting for Potential Issues**

| <b>Symptom</b>                                | <b>Probable Cause</b>                     | <b>Corrective Action / Remedy</b>  |
|---|---|--|
| No hot water                                  | Circuit breaker tripped at source         | Reset circuit breaker.   |
|   | High limit switch tripped                 | Reset high limit switch.   |
|   | Loose wires                               | Tighten wire connections.  |
|   | Low line voltage                          | Have source electrical system checked by an electrician.   |
|   | Faulty controller                         | If controller display is not lit and power is available at the controller, check wire connections then replace controller.   |
|   | Faulty temperature sensor(s) / controller | If the temperature indicated by the controller when set to display the actual temperature does not match the actual temperature of the water (within $\pm 5^{\circ}\text{F}$ ), replace controller and/or temperature sensors. |
|   | Controller Error                          | See controller error codes below.  |
|   | Incorrect set point (too low)             | Increase the set point.  |
| <b>Symptom</b>                                | <b>Probable Cause</b>                     | <b>Corrective Action / Remedy</b>  |
| Water temperature below settings at all times | Faulty temperature sensor(s) / controller | If the temperature indicated by the controller when set to display the actual temperature does not match the actual temperature of the water (within $\pm 5^{\circ}\text{F}$ ), replace controller and/or temperature sensors. |
|   | Low line voltage                          | Have source electrical system checked by an electrician.   |
|   | Incorrect set point (too low)             | Increase the set point.  |
|   | Heater improperly sized                   | Verify heater is properly sized for the flow rate and temperature rise of your system. Replace elements with proper size as necessary.   |

|                                      |   |   |
|--------------------------------------|---|---|
| Relief valve discharges continuously | Excessive temperature or pressure in tank | Temperature and pressure relief valves are designed to operate if the water temperature exceeds 210°F or tank pressure exceeds the pressure rating of the safety relief valve. If trouble is excessive temperature, then controller is not shutting off at the set point and controller must be replaced. If pressure, likely cause is thermal expansion. Contact plumber and consider installing a thermal expansion tank. |
|--------------------------------------|---|---|

## Controller Error Messages and Procedures

### Lockout Codes

Errors are indicated starting with an ‘A’:

**Table 17 - Lockout Error Codes**

| Display 'Loc' | Error                   | Int nr. | Description   |
|---------------|-------------------------|---------|---|
| 0             | E2PROM_READ_ERROR       | 0       | Internal software error   |
| 1             | IGNIT_ERROR             | 1       | Three unsuccessful ignition attempts in a row   |
| 2             | GV_RELAY_ERROR          | 2       | Failure detected in the GV relay  |
| 3             | SAFETY_RELAY_ERROR      | 3       | Failure detected in safety relay  |
| 4             | BLOCKING_TOO_LONG       | 4       | Control had a blocking error for more than 20 hours   |
| 5             | FAN_ERROR               | 5       | Fan deviates too much for more than 60 seconds  |
| 6             | FAN_ERROR_TOO_SLOW      | 6       | Fan runs too slow for more than 60 seconds  |
| 7             | FAN_ERROR_TOO_FAST      | 7       | Fan runs too fast for more than 60 seconds  |
| 8             | RAM_ERROR               | 8       | Internal software error   |
| 9             | WRONG_EEPROM_SIGNATURE  | 9       | Contents of E2prom is not up to date  |
| 10            | E2PROM_ERROR            | 10      | Wrong safety parameters in E2prom   |
| 11            | STATE_ERROR             | 11      | Internal software error   |
| 12            | ROM_ERROR               | 12      | Internal software error   |
| 13            | APS_NOT_OPEN            | 13      | Air pressure switch not working   |
| 14            | APS_NOT_CLOSED          | 14      | Air pressure switch not working   |
| 15            | MAX_TEMP_ERROR          | 15      | The external overheat protection is enabled or the <i>T_Supply</i> sensor measures a temperature of over 100°C (212°F)      |
| 16            | FLUE_GAS_ERROR          | 16      | Flue temperature exceeded the maximum flue temperature<br>This error can only be reset when a jumper is placed on the board |
| 17            | STACK_ERROR             | 17      | Internal software error   |
| 18            | INSTRUCTION_ERROR       | 18      | Internal software error   |
| 19            | ION_CHECK_FAILED        | 19      | Internal software error   |
| 20            | FLAME_OUT_TOO_LATE      | 20      | Flame still present 10 seconds after closing the gas valve  |
| 21            | FLAME_BEFORE_IGNIT      | 21      | Flame is detected before ignition   |
| 22            | TOO_MANY_FLAME_LOSS     | 22      | Three time flame lost during 1 demand   |
| 23            | FLOW_SWITCH_NOT_CLSD    | 23      | Flow switch not working   |
| 24            | FLUE_SWITCH_NOT_CLOSING | 24      | The blocked flue sensor is not closed within 10 minutes   |
| 25            | TSUPPLY_DIFF_ERROR      | 25      | The 2 supply sensors deviate too much for more than 60 seconds  |
| 26            | TFLUE_DIFF_ERROR        | 26      | The 2 flue sensors deviate too much for more than 60 seconds  |
| 27            | FILLING_TOO_MUCH        | 27      | Too many automated filling attempts in a short time period  |
| 28            | FILL_TIME_ERROR         | 28      | Filling takes too long  |
| 29            | PSM_ERROR               | 29      | Internal software error   |
| 30            | REGISTER_ERROR          | 30      | Internal software error   |

**NOTICE:** A24 is an error for either a blocked flue or a blocked condensate and requires inspection of both.

## **Blocking Errors**

The following errors are related to the general control functions. Errors are indicated starting with an ‘E’:

**Table 18 - Blocking Error Codes**

| Display 'Err' | Error                        | Int nr. | Description  |
|---------------|------------------------------|---------|--|
| 100           | WD_ERROR_RAM                 | 100     | Internal software error  |
| 101           | WD_ERROR_ROM                 | 101     | Internal software error  |
| 102           | WD_ERROR_STACK               | 102     | Internal software error  |
| 103           | WD_ERROR_REGISTER            | 103     | Internal software error  |
| 104           | WD_ERROR_XRL                 | 104     | Internal software error  |
| 105           | HIGH_TEMP_ERROR              | 105     | Supply temperature exceeds 110°C with gas valve closed                   |
| 106           | REFHI_TOO_HIGH               | 106     | Internal hardware error  |
| 107           | REFHI_TOO_LOW                | 107     | Internal hardware error  |
| 108           | REFLO_TOO_HIGH               | 108     | Internal hardware error  |
| 109           | REFLO_TOO_LOW                | 109     | Internal hardware error  |
| 110           | REFHI2_TOO_HIGH              | 110     | Internal hardware error  |
| 111           | REFHI2_TOO_LOW               | 111     | Internal hardware error  |
| 112           | REFLO2_TOO_HIGH              | 112     | Internal hardware error  |
| 113           | REFLO2_TOO_LOW               | 113     | Internal hardware error  |
| 114           | FALSE_FLAME                  | 114     | Flame is detected in a state in which no flame is allowed to be seen     |
| 115           | LOW_WATER_PRESSURE_ERROR     | 115     | Low water pressure error   |
| 116           | LOW_WATER_PRESSURE_SENSOR    | 116     | Low water pressure   |
| 117           | BLOCKED_DRAIN                | 117     | Block drain switch is active   |
| 118           | WD_COMM_ERROR                | 118     | Watchdog communication error   |
| 119           | RETURN_OPEN                  | 119     | Return sensor open   |
| 120           | SUPPLY_OPEN                  | 120     | Supply sensor open   |
| 121           | SUPPLY2_OPEN                 | 121     | Supply 2 sensor open   |
| 122           | DHW_OPEN                     | 122     | DHW sensor open  |
| 123           | FLUE_OPEN                    | 123     | Flue sensor open   |
| 124           | FLUE2_OPEN                   | 124     | Flue 2 sensor open   |
| 125           | OUTDOOR_OPEN                 | 125     | Outdoor sensor open  |
| 126           | RETURN_SHORTED               | 126     | Return sensor shorted  |
| 127           | SUPPLY_SHORTED               | 127     | Supply sensor shorted  |
| 128           | SUPPLY2_SHORTED              | 128     | Supply 2 sensor shorted  |
| 129           | DHW_SHORTED                  | 129     | DHW sensor shorted   |
| 130           | FLUE_SHORTED                 | 130     | Flue sensor shorted  |
| 131           | FLUE2_SHORTED                | 131     | Flue 2 sensor shorted  |
| 132           | OUTDOOR_SHORTED              | 132     | Outdoor sensor shorted   |
| 133           | GAS_PRESSURE_ERROR           | 133     | Gas pressure switch error  |
| 134           | RESET_BUTTON_ERROR           | 134     | Too many resets in a short time period                                   |
| 135           | PHASE_NEUTRAL_RESERVED_ERROR | 135     | The live and neutral of the main voltage power supply input are reversed |



## **6.0 MAINTENANCE & SERVICING**

### **WARNING / CAUTION**

Before servicing or replacing any part make sure to turn the power supply switch to the OFF position.

#### **Surface Temperature Hi-Limit Cutout Switch**

1. Disconnect power from unit.
2. Remove upper access cover.
3. Disconnect the wires from the four terminals.
4. Remove hi-limit switch.
5. Install new high limit switch.
6. Rewire hi-limit switch according to wiring diagram.
7. Reinstall access cover.

#### **Removing the Condensate Outlet**

1. Disconnect power from the unit.
2. Shut gas valves to stop incoming gas supply.
3. Open the gas unit housing.
4. Undo the PVC union near the left side of the enclosure.
5. Disconnect hose clamps on the condensate drain from PVC side outlet elbow.
6. Remove the two nuts holding the condensate box to the heat exchanger.
7. Remove PVC exhaust/condensate outlet assembly.

#### **Removing the Fan Assembly**

1. Disconnect power from the unit.
2. Shut gas valves to stop incoming gas supply.
3. Open the gas unit housing.
4. Remove hose clamp on air inlet on fan side.
5. Disconnect air hose.
6. Remove gas line from gas valve.
7. Remove Condensate Outlet- see above.
8. Remove the 4 bolts and nuts from the fan connector.
9. Remove fan assembly.

#### **Heat Exchanger**

1. Disconnect power from the unit.
2. Shut gas valves to stop incoming gas supply.
3. Shut off incoming water supply.
4. Attach hose to a drain connection.
5. Open hot water faucet to allow tank to drain completely.
6. Open the gas unit housing.

7. Remove the condensate outlet. See above.
8. Remove the fan assembly. See above.
9. Disconnect wires from the spark electrode and ionization probe.
10. Remove the 8 bolts and nuts.
11. Remove the heat exchanger and replace with a new one.
12. Ensure both O-rings are placed correctly.
13. Replace all nuts and bolts.
14. Replace condensate box.
15. Replace fan assembly.
16. Replace wires.
17. Fill the tank and check around for any leaks.
18. Reopen gas valves and turn on power.

## **Relief Valve**

1. Disconnect power from unit.
2. Shut off incoming water supply.
3. Lift test lever on relief valve to relieve pressure in tank.
4. Disconnect overflow piping.
5. Unscrew relief valve, remove assembly and replace with new one.
6. Connect overflow piping.
7. Turn on incoming water supply and check for leaks.

## **Heating Element (If Equipped)**

1. Disconnect power from unit.
2. Shut off incoming water supply.
3. Attach hose to drain connection.
4. Open hot water faucet to allow tank to drain completely.
5. Remove upper and/or lower access cover, as applicable.
6. Disconnect the wires from the heating element terminals.
7. Remove the element from the tank.
8. Install new gasket and new heating element.
9. Rewire element according to wiring diagram.
10. Fill tank and check around gasket for any leaks. Tighten nuts as required.
11. Reinstall access cover(s).

Figure 24 – Wiring Diagram of Burner Control

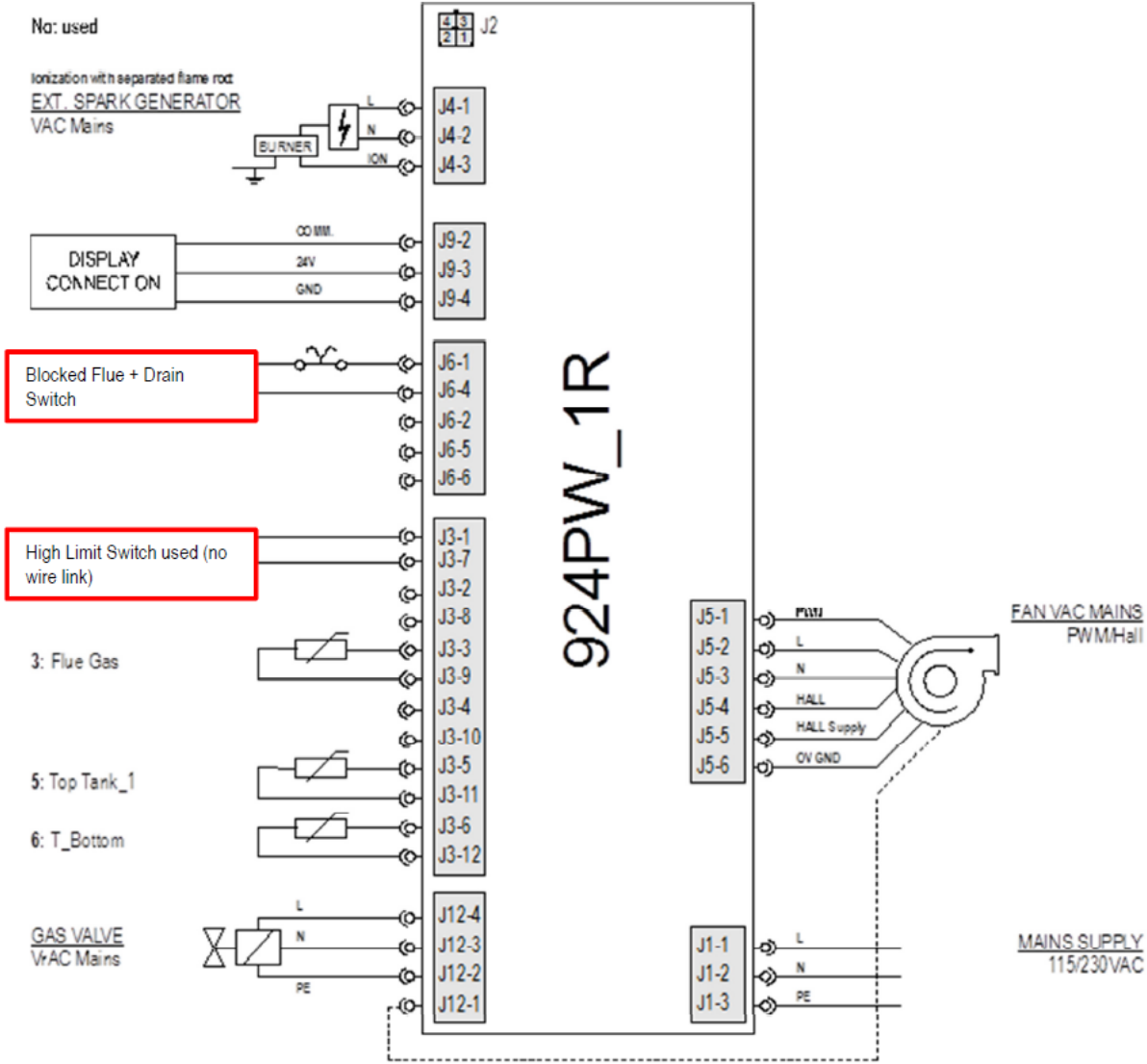

## 7.0 REPLACEMENT OF PARTS

For replacement parts, please reference the list below. All the following parts can be supplied by Hubbell Heater Company.

| HUBBELL DRAWING NUMBER | PART NUMBER                     | DESCRIPTION                                     | QTY. 55k | QTY. 110k |
|------------------------|---------------------------------|---|----------|-----------|
|                        |                                 | Heat Exchanger                                  | 1        | 2         |
| V24S0021               | GA0101625                       | Mounting Plate O Ring                           | 1        | 2         |
| V24S0022               | GA0101675                       | Stretched Mounting Plate O Ring                 | 1        | 2         |
| V24S0023               | FA200102528075                  | 1/4"-28 x 3/4" UNF Stud                         | 4        | 8         |
| V24S0023               | FA050102528125                  | 1/4"-28 x 1 1/4" Bolt                           | 6        | 12        |
|                        | FA2001025200                    | 1/4"-28 x 2" Stud                               | 2        | 4         |
| V24S0024               | FA0401025000                    | 1/4" Washer                                     | 10       | 20        |
|                        | FA1101025000                    | 1/4" Lock Washer                                | 8        | 16        |
| V24S0025               | FA030102528                     | 1/4" (28) UNF Nut                               | 18       | 36        |
| V24S0031               | GP3810000000000                 | Mounting Plate                                  | 1        | 2         |
|                        | <a href="#">GP2000000000000</a> | Display   | 1        | 2         |
|                        | GP2100000000000                 | Burner Control                                  | 1        | 2         |
|                        | GP2300000000000                 | Ignition Transformer                            | 1        | 2         |
|                        | MS051042000001                  | Air Pressure Switch                             | 1        | 2         |
| V24S0080               | GP150253155817                  | Fan Coupler Type                                | 1        | 2         |
| V24S0041               | GP160110047323                  | Burner  | 1        | 2         |
|                        | GP1900000000000                 | Fan   | 1        | 2         |
|                        | GP2403057200000                 | Venturi   | 1        | 2         |
|                        | GP2500000000000                 | Gas Valve                                       | 1        | 2         |
|                        | GP2200005000000                 | Flange Kit 1/2"NPT Straight                     | 1        | 2         |
| V24S0042               | GP170000383840                  | Spark Electrode                                 | 1        | 2         |
| V24S0043               | GP180000385140                  | Ionization Probe                                | 1        | 2         |
| V24S0036               | GA1003374                       | Electrode Seal                                  | 2        | 4         |
| V24S0047               | GA11043140                      | Fan Gasket                                      | 1        | 2         |
| V24S0048               | GA12054726                      | Fan Coupler Gasket                              | 1        | 2         |
| V24S0049               | GA13051063                      | Burner Gasket                                   | 1        | 2         |
| V24S0050               | GA1406449                       | Insulation Pad                                  | 1        | 2         |
| V24S0051               | GA1507827                       | Exhaust Seal                                    | 2        | 4         |
| V24S0044               | FA18011032075                   | #10-32 x 3/4" Allen Head Bolt (Fan)             | 4        | 8         |
| V24S0045               | FA03011032000                   | #10-32 Nut (Fan)                                | 4        | 8         |
| V24S0046               | FA04010010000                   | #10 Washer (Fan)                                | 8        | 16        |
|                        | FA0403008000                    | #8 Internal Thread Washer (Burner)              | 4        | 8         |
|                        | FA1803832025                    | #8-32 x 1/4" Allen Head Bolt (Burner)           | 4        | 8         |
| V24S0070               | FA1801832375                    | #8-32 x 3/8" Allen Head Bolt (Spark/Ionization) | 4        | 8         |
| V24S0052               | FA1607375000                    | Cable Gland                                     | 1        | 1         |

|          |                 |                                 |    |    |
|----------|-----------------|---------------------------------|----|----|
|          | FA0304375000    | Cable Gland Nut                 | 1  | 1  |
| V24S0053 | FA1708075000    | Condensate Connector            | 1  | 2  |
| V24S0074 | FA03083015000   | Condensate Nut                  | 1  | 2  |
| V24S0054 | GP2604005000000 | 1/2" FPT Brass Term Bolt        | 1  | 2  |
| V24S0055 | GP2701005018000 | 1/2" Gas Line S.S.              | 1  | 2  |
| V24A0020 |                 | PVC Exhaust Assembly            | 1  | 1  |
|          |                 | PVC Exhaust Assembly (Upper)    | -  | 1  |
|          | PL041471606     | Flue Plug                       | 1  |    |
| V24S0065 | GA16071428      | O-Ring SSL 35 x 2.0             | 1  |    |
|          | MS0500000000029 | 1/2" NPT Float Switch           | 1  | 2  |
|          | FT36100125000   | 1/8" NPT Barbed Hose Fitting    | 1  | 2  |
| V24S0071 | GP3508002120000 | Condensate Pipe with Loop       | 1  | 2  |
|          | GP3608002100000 | Condensate Joining Sleeve       | 2  | 4  |
|          | FA080820000     | Condensate Hose Clamp           | 4  | 8  |
| V24S0072 | GP3709019700000 | Air Duct                        | 1  | 2  |
| V24S0075 | FA0803200000    | Air Duct Hose Clamp             | 2  | 4  |
|          | FA0301A24000    | #10-24 Nut (Controller/Igniter) | 7  | 14 |
|          | FA0301832000    | #8-32 Nut (Display)             | 8  | 16 |
|          | FA210420000     | Snap Rivet (Mounting Plate)     | 12 | 12 |

## WARRANTY

### Tank/Heat Exchanger Replacement Policy One Year Limited Parts Warranty

Hubbell Heater Company, (hereinafter called the company) offers the following Limited Warranty and Tank Replacement Policy to the purchaser/owner of this stone-lined residential water heater.

This Limited Warranty and Tank Replacement Policy is not transferable beyond the original purchaser/owner and is not valid if tank is removed from initial installation site. The Company reserves the right to require proof of purchase as a condition of this warranty. Excludes any implied warranty of merchantability or fitness for any particular purpose.

#### **LIMITED WARRANTY**

##### **COMPONENT REPLACEMENT POLICY**

**DURATION:** The warranty is effective for (1) year beginning with the date of original purchase.

**COVERAGE:** The warranty covers any component part of the water heater proven to be defective in workmanship or material. Recovery under the terms of this agreement is subject to prior approval by the company.

**COMPANY OBLIGATION:** Repair or replacement is at the option of the company and constitutes the fulfillment of **ALL** obligations of the Company hereunder.

**LIMITATION:** All repairs or replacements will be made F.O.B. the company. The purchaser must pay for transportation service, labor, installation, administrative fees or other costs involving the repair or replacement of such component parts.

**YOUR ACTION:** When you discover a defect, immediately notify your local representative from whom the heater was purchased. If you cannot locate the representative, contact the Company.

##### **TANK REPLACEMENT POLICY**

**DURATION:** (7) years from the date of original purchase. Exception: (10) years for ASME Stamped Vessels, see Limitations below.

**COVERAGE:** Replacement policy covers only the storage tank for leaks caused by the corrosive effects of the water under normal and proper use. Recovery under the terms of this agreement is subject to prior approval by the company. The tank replacement policy excludes any performance warranty implied or specific of merchantability and fitness for its intended use.

**COMPANY OBLIGATION:** Repair of the original tank or replacement of the entire heater with a new comparable model is at the option of the Company and constitutes the fulfillment of all the obligations of the Company hereunder. In replacing or repairing the water heater, the Company reserves the right to make such changes in details of design, construction or material as shall in their judgment constitute an improvement of former practices.

**REPLACEMENT:** When a replacement is made under the terms of this policy, the replacement unit will have a policy of replacement only for the remaining time under the original policy. The Company reserves the right to require return of the defective unit at the expense of the purchaser.

**LIMITATION:** All repairs or replacements will be made F.O.B. the Company. The purchaser must pay for transportation, service, labor installation, administrative fees or other costs involving the repair or replacement of such part

**YOUR ACTION:** When you discover a defect, immediately notify the representative from whom the heater was purchased. If you cannot locate the representative, contact the Company

##### **HEAT EXCHANGER REPLACEMENT POLICY**

**DURATION:** (5) years from the date of original purchase, see Limitations below.

**COVERAGE:** Replacement policy covers only the heat exchanger for leaks caused by the corrosive effects of the water under normal and proper use. Recovery under the terms of this agreement is subject to prior approval by the company. The tank replacement policy excludes any performance warranty implied or specific of merchantability and fitness for its intended use.

**COMPANY OBLIGATION:** Repair of the original heat exchanger or replacement of the entire heat exchanger with a new comparable model is at the option of the Company and constitutes the fulfillment of all the obligations of the Company hereunder. In replacing or repairing the heat exchanger, the Company reserves the right to make such changes in details of design, construction or material as shall in their judgment constitute an improvement of former practices.

**REPLACEMENT:** When a replacement is made under the terms of this policy, the replacement unit will have a policy of replacement only for the remaining time under the original policy. The Company reserves the right to require return of the defective unit at the expense of the purchaser.

**LIMITATION:** All repairs or replacements will be made F.O.B. the Company. The purchaser must pay for transportation, service, labor installation, administrative fees or other costs involving the repair or replacement of such part

**YOUR ACTION:** When you discover a defect, immediately notify the representative from whom the heater was purchased. If you cannot locate the representative, contact the Company

### EXCLUSIONS AND LIMITATIONS

Limited Warranty and Tank/Heat Exchanger Replacement Policy are valid only if you comply with the following conditions and limitations:

1. The water heater must be correctly installed according to the installation manual provided with the unit and all applicable local and national codes.
2. The unit must be operated within the factory calibrated temperature limits and water pressure not exceeding 150 psi.
3. Any failure or malfunction that results from improper or negligent operation, accident, abuse (including freezing), misuse, unauthorized alteration or improper maintenance is specifically excluded.
4. Any failure or malfunction that results from failure to keep the tank full of potable water, free to circulate at all times, and free of damaging water sediment or scale deposits, is specifically excluded. In areas where adverse water conditions are suspected (i.e. calcium and other minerals), it is essential that the water be tested and appropriate action be taken to prevent damage to the water heater.
5. This Limited Warranty and Tank Replacement Policy specifically exclude any implied warranty of merchantability or of fitness for any particular purpose, as well as any performance warranty.

**IN NO EVENT SHALL THE COMPANY BE LIABLE FOR ANY INCIDENTAL OR CONSEQUENTIAL DAMAGES WHATSOEVER.** Some states do not allow the exclusion or limitation of implied warranties or of liability for incidental or consequential damages, so the above limitation(s) or exclusion(s) may not apply to you.

## List of Figures

|   |    |
|---|----|
| Figure 1 - Tank Assembly (55k Btu Unit on top, 110k Unit on bottom) ..... | 8  |
| Figure 2 - Ventilation Connections .....                                  | 13 |
| Figure 3 - Two Pipe Termination (Sidewall).....                           | 17 |
| Figure 4 - Two Pipe Low Profile Termination (Sidewall) .....              | 18 |
| Figure 5 - Two Pipe Concentric Termination (Sidewall).....                | 18 |
| Figure 6 - Two Pipe Termination (Roof).....                               | 19 |
| Figure 7 - Two Pipe Concentric Termination (Roof).....                    | 19 |
| Figure 8 –Venting Below Grade.....  | 21 |
| Figure 9 - Outdoor Venting Guidelines.....                                | 21 |
| Figure 10 – Existing Chimney Chase Way .....                              | 21 |
| Figure 11 - Basic Ventilation Layout .....                                | 23 |
| Figure 12 - Condensate Outlet Location.....                               | 24 |
| Figure 13 - Gas Inlet Location.....                                       | 25 |
| Figure 14 – Multiventuri Operating Principle .....                        | 27 |
| Figure 15 – Gas Valve Operating Principle.....                            | 27 |
| Figure 16 – Gas Valve Diagram .....                                       | 28 |
| Figure 17 – Gas Valve Schematic .....                                     | 29 |
| Figure 18 – Gas Valve Calibration .....                                   | 30 |
| Figure 19 – Test Port Location .....                                      | 30 |
| Figure 20 – Water Piping Installation Diagram.....                        | 31 |
| Figure 21 – Mixing Valve Water Piping Installation Diagram .....          | 32 |
| Figure 22 - LCD Symbols .....   | 34 |
| Figure 23 - Lay-out with Push Buttons .....                               | 35 |
| Figure 24 – Wiring Diagram of Burner Control.....                         | 46 |

## List of Tables

|   |    |
|---|----|
| Table 1- Model Specific Dimensional Data .....  | 9  |
| Table 2 - Possible Ventilation Contaminants .....                                       | 14 |
| Table 3 - Vent/Air-inlet Pipe Materials .....   | 15 |
| Table 4 - Vent and Air-inlet Pipe Length Determination.....                             | 15 |
| Table 5 - Vent and Air-inlet Pipe Length Determination (Common Vented Double Unit)..... | 16 |
| Table 6 - Vent and Air-intake Termination Clearances .....                              | 22 |
| Table 7 - Gas Unit Values .....   | 28 |
| Table 8 - Status Symbols and Their Meanings.....  | 35 |
| Table 9 - Button Functions .....  | 36 |
| Table 10 - Important Icon Descriptions.....   | 36 |
| Table 11 - User Menu Guide .....  | 37 |
| Table 12 - Parameter List and Descriptions .....  | 38 |
| Table 13 - Installer Menu Guide.....  | 38 |
| Table 14 - Installer Menu Parameter List.....   | 39 |
| Table 15 - Descriptions of Errors .....   | 39 |
| Table 16 - Troubleshooting for Potential Issues.....                                    | 41 |
| Table 17 - Lockout Error Codes .....  | 42 |
| Table 18 - Blocking Error Codes.....  | 43 |