



**IMPORTANT NOTE:**

Locate the Specification Label on unit to determine exact Model Name and electrical specifications. This information is needed to identify the correct replacement parts. See exploded view illustration(s) for Specification Label location.



Use of replacement parts other than those supplied by Hatco Corporation may result in damage to unit or injury to personnel and will void all warranties.

# Flav-R-Savor®

## Humidified Large Capacity Display Cabinets

### WFST Series

<u>Model Name</u>	<u>Page</u>
WFST-1X.....	2
WFST-2X.....	2

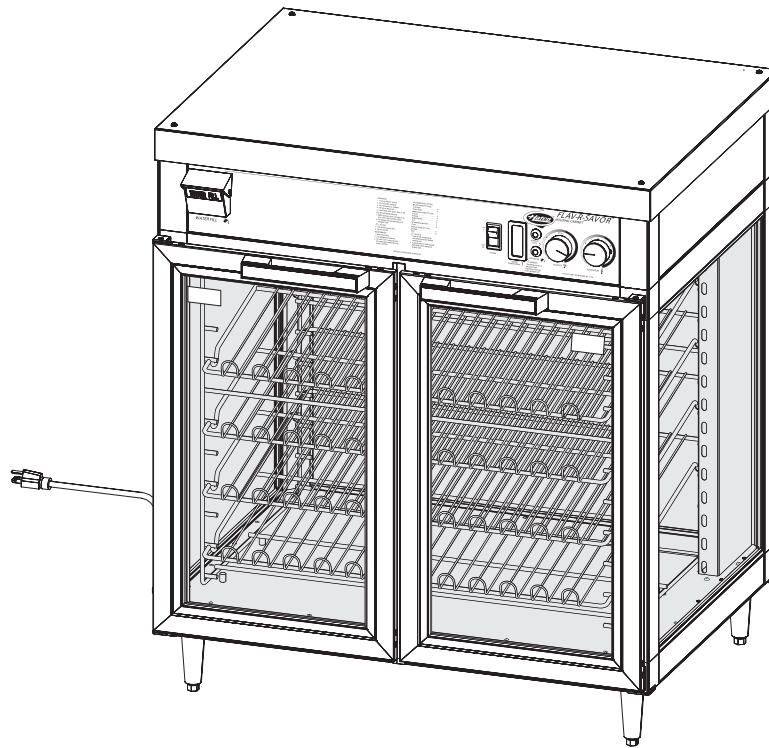

# Replacement Parts List

# Hatco Flav-R-Savor® Humidified Large Capacity Display Cabinets

## WFST Series

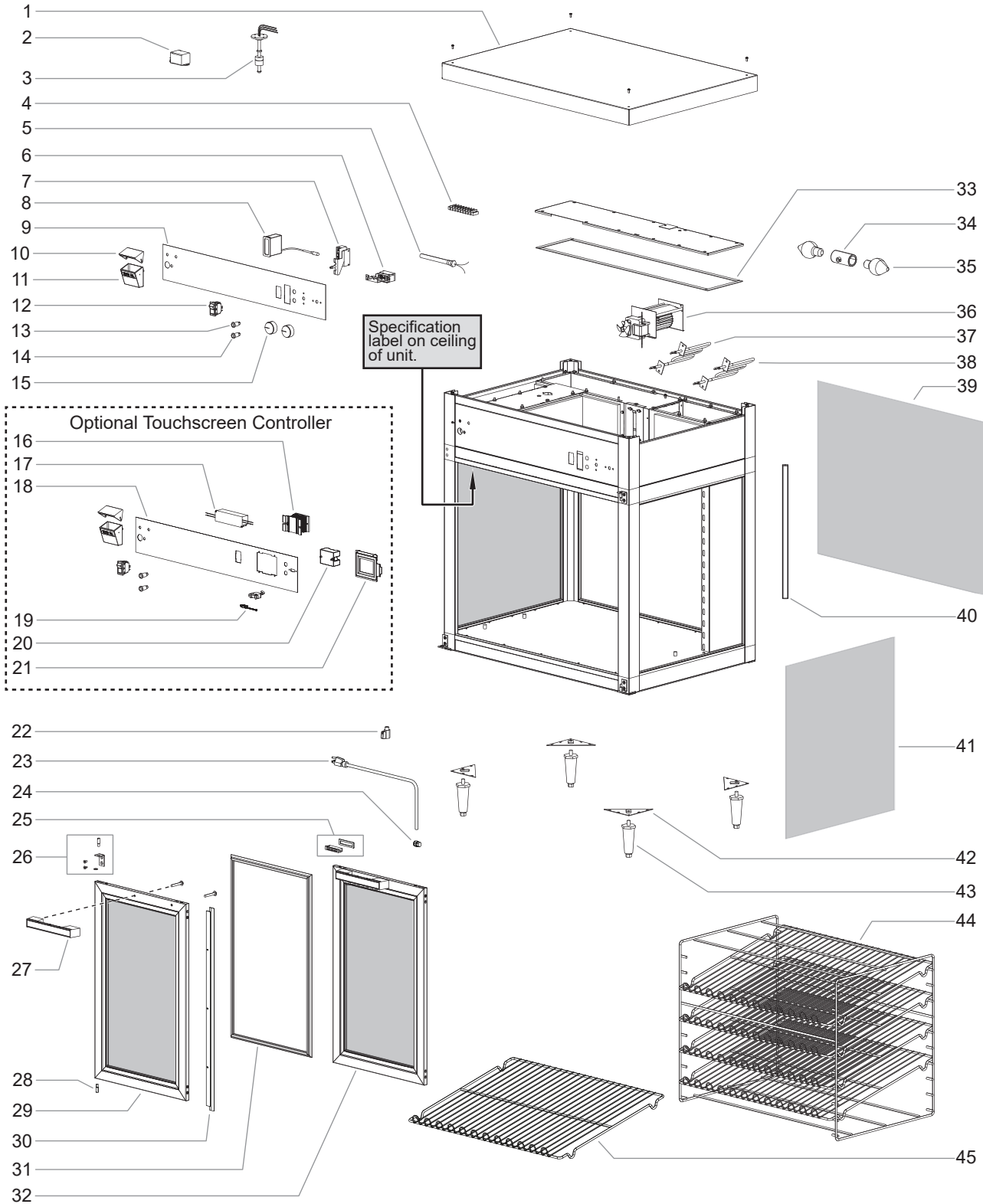

NOTE: Quantities shown as a range (example = "2-4") are dependent upon the number of doors on a unit.

The shaded areas contain information for **international models only**.

NOTE: The last four digits in a ten digit numerical serial number are the manufacturing date code: 962506**2004**

Year 2020  
Week Four

Item	Description	Part No.	Qty.
1	Hood	04.17.438.00	1
2	Relay, Mechanical Controller		
	120 V	02.01.028.00	1
	220 V and 240 V	02.01.043.00	1
3	Float Switch	R02.01.029.00	1
4	Terminal Block	02.15.012.00	1
5	Water Element, 600 W		
	120 V	R02.05.002.00	1
	220 V	R02.05.018.00	1
	240 V	R02.05.003.00	1
6	Thermostat	02.16.002.00	1
7	Humidity Thermostat	02.16.021.00	1
8	Temperature Display	02.16.049.00	1
9	Label, Mechanical Control		
	Humidified	07.03.160.00	1
	Non-Humidified	07.01.113.00	1
10	Fill Cup Cover	05.30.051.00	1
11	Fill Cup w/Cover	R05.30.050.00	1
12	Rocker I/O (on/off) Switch	02.19.015.00	1
13	Pilot Light, Green		
	120 V	02.19.155.00	1
	220 V and 240 V	02.19.150.00	1
14	Pilot Light, Red		
	120 V	02.19.154.00	1
	220 V and 240 V	02.19.151.00	1
15	Knob	05.30.019.00	2
16	Heat Sink	04.09.872.00	1
17	LED Driver	02.01.345.00	1
18	Label, Touchscreen Controller		
	Humidified	07.03.1032.00	1
	Non-Humidified	07.01.1050.00	1
19	USB Cable	02.20.435.00	1
20	Relay, Touchscreen Controller	02.01.355.00	1
21	Touchscreen Controller	R02.01.448.11	1
22	Drain Valve	03.40.105.00	1
23	Power Cord and Plug		
	120 V, NEMA 5-15P	02.18.154.00	1
	120 V, NEMA 5-20P (Canada)	02.18.089.00	1
	120/208-240 V, NEMA L14-20P	02.18.128.00	1
	220 V, CEE 7/7	02.18.077.00	1
	240 V, BS-1363	02.18.068.00	1
24	Cord Grip		
	120 V	02.20.226.00	1
	240 V	02.20.206.00	1
25	Door Magnet Kit (Date Code 1752 and older only)	R05.30.005.00	2-4
26	Door Hinge Kit (includes item 28)	R00.01.0110.00	2-4
	Door Hinge Kit, Self-Closing		
	Right Door	R04.17.512.00	1-2
	Left Door	R04.17.511.00	1-2
27	Handle, Door	R05.30.012.00	2-4
28	Door Hinge Screw	05.04.146.00	4-8

Item	Description	Part No.	Qty.
29	Door Assembly, Left		
	French Door (includes items 26, 27, 30, 31)	R00.01.0108.00	1-2
	Sliding Door (not shown)	R00.01.0041.00	1-2
	Self-Closing Door (not shown)	R00.01.0046.00	1-2
30	Center Gasket, Door	05.06.197.00	1-2
31	Door Gasket	R00.01.0122.00	2-4
32	Door Assembly, Right		
	French Door (includes items 26, 27, 31)	R00.01.0109.00	1-2
	Sliding Door (not shown)	R00.01.0042.00	1-2
	Self-Closing Door (not shown)	R00.01.0047.00	1-2
33	Gasket (sold by the foot)	05.06.028.00	9'
34	Light Socket	R02.30.323.00	2
35	Light Bulb		
	120 V	02.30.265.00	4
	220 V and 240 V	02.30.058.00	4
36	Blower Motor		
	120 V	R02.12.003.00	1
	220 V and 240 V	R02.12.012.00	1
37	Air Element, 800 W		
	120 V	R02.08.010A.00	1
	220 V	R02.08.011F.00	1
	240 V	R02.08.574E.00	1
38	Air Element, 875 W		
	120 V	R02.08.090.00	1
	220 V	R02.08.094E.00	1
	240 V	R02.08.095E.00	1
39	Front, Glass	04.40.079.00	1
40	LED Channel	02.30.205.00	2
41	Side, Glass	04.40.008.00	2
42	Bracket, Leg	R04.17.067.00	4
43	Adjustable Legs, 4"	05.30.007.00	4
44	Rack, 4-Shelf Multi-Purpose (includes item 45)	R04.17.440.00	1
45	Removable Shelf	04.17.440A.00	4
	Wiring Diagrams		
	Humidified Units w/ LED Lighting		
	120 V, 220 V, 240 V	s	
	Mechanical Controls	10-01-1598	
	Touchscreen Controls	10-01-1577	
	120/208-240 V		
	Mechanical Controls	10-01-1599	
	Touchscreen Controls	10-01-1601	
	Non-Humidified Units w/ LED Lighting		
	Mechanical Controls	10-01-1059	
	Touchscreen Controls	10-01-1602	
	Humidified Units w/ Incandescent Lighting		
	120 V	HS1-3596	
	120/208-240 V	10-01-207	
	220 V	HS1-3680	
	240 V	HS1-3681	

# AUTHORIZED PARTS DISTRIBUTORS • AUTORISÉS DISTRIBUTEURS DE PIÈCES

## ALABAMA

Jones McLeod Appl. Svc.  
Birmingham 205-251-0159

## ARIZONA

Tech 24  
Phoenix 602-234-2443

Byassee Equipment Co.  
Phoenix 602-252-0402

## CALIFORNIA

Industrial Electric  
Commercial Parts & Service, Inc.  
Huntington Beach 714-379-7100

Chapman Appl. Service  
San Diego 619-298-7106

P & D Appliance  
Commercial Parts & Service, Inc.  
S. San Francisco 650-635-1900

## COLORADO

Hawkins Commercial Appliance  
Englewood 303-781-5548

## FLORIDA

Whaley Foodservice Repair  
Jacksonville 904-725-7800

Whaley Foodservice Repair  
Orlando 407-757-0851

B.G.S.I./Heritage  
Pompano Beach 954-971-0456

Comm. Appliance Service  
Tampa 813-663-0313

## GEORGIA

Heritage Service Group  
Norcross 866-388-9837

## HAWAII

Burney's Comm. Service, Inc.  
Honolulu 808-848-1466

Food Equip Parts & Service  
Honolulu 808-847-4871

## ILLINOIS

Parts Town  
Addison 708-865-7278

Eichenauer Elec. Service  
Decatur 217-429-4229

Midwest Elec. Appl. Service  
Elmhurst 630-279-8000

Cone's Repair Service  
Moline 309-797-5323

## IOWA

Goodwin Tucker Group  
Des Moines 515-262-9308

## KENTUCKY

Tech 24  
Lexington 859-254-8854

Tech 24  
Louisville 502-451-5411

## LOUISIANA

Chandlers Parts & Service  
Baton Rouge 225-272-6620

## MARYLAND

Electric Motor Service  
Baltimore 410-467-8080

## MASSACHUSETTS

Ace Service Co., Inc.  
Needham 781-449-4220

## MICHIGAN

Bildons Appliance Service  
Detroit 248-478-3320

Commercial Kitchen Service  
Bay City 989-893-4561

Midwest Food Equip. Service  
Grandville 616-261-2000

## MISSOURI

General Parts  
Kansas City 816-421-5400

Commercial Kitchen Services  
St. Louis 314-890-0700

Kaemmerlen Parts & Service  
St. Louis 314-535-2222

## NEBRASKA

Anderson Electric  
Omaha 402-341-1414

## NEVADA

Burney's Commercial  
Las Vegas 702-736-0006

Hi. Tech Commercial Service  
N. Las Vegas 702-649-4616

## NEW JERSEY

Jay Hill Repair  
Fairfield 973-575-9145

Service Plus  
Flanders 973-691-6300

## NEW YORK

Alpro Service Co.  
Maspeth 718-386-2515

Duffy's - AIS  
Buffalo 716-884-7425

3Wire  
Plattsburgh 800-634-5005

Duffy's - AIS  
Sauquoit 800-836-1014

J.B. Brady, Inc.  
Syracuse 315-422-9271

## NORTH CAROLINA

Authorized Appliance  
Charlotte 704-377-4501

## OHIO

Akron/Canton Comm. Svc. Inc.  
Akron 330-753-6634

Tech 24  
Cincinnati 513-772-6600

Commercial Parts and Service  
Columbus 614-221-0057

Electrical Appl. Repair Service  
Brooklyn Heights 216-459-8700

E. A. Wichman Co.  
Toledo 419-385-9121

## OKLAHOMA

Hagar Rest. Service, Inc.  
Oklahoma City 405-235-2184

## OREGON

General Parts Group  
Portland 503-624-0890

## PENNSYLVANIA

Elmer Schultz Services  
Philadelphia 215-627-5401

FAST Comm. Appl. Service  
Philadelphia 215-288-4800

AIS Commercial Parts and Service  
Pittsburgh 412-809-0244

K & D Service Co.  
Harrisburg 717-236-9039

Electric Repair Co.  
Reading 610-376-5444

## RHODE ISLAND

Marshall Electric Co.  
Providence 401-331-1163

## SOUTH CAROLINA

Whaley Foodservice Repair  
Lexington 803-996-9900

## TENNESSEE

Camp Electric  
Memphis 901-527-7543

## TEXAS

Armstrong Repair Service  
Houston 713-666-7100

Cooking Equipment Specialist  
Mesquite 972-686-6666

Commercial Kitchen Repair Co.  
San Antonio 210-735-2811

## UTAH

La Monica's Rest. Equip. Service  
Murray 801-263-3221

## VIRGINIA

Daubers  
Norfolk 757-855-4097

Daubers  
Springfield 703-866-3600

## WASHINGTON

3Wire  
Seattle 800-207-3146

## WISCONSIN

A.S.C., Inc.  
Madison 608-246-3160

A.S.C., Inc.  
Milwaukee 414-543-6460

## CANADA

### ALBERTA

Key Food Equipment Service  
Edmonton 780-438-1690

### BRITISH COLUMBIA

Key Food Equipment Service  
Vancouver 604-433-4484

Key Food Equipment Service  
Victoria 250-920-4888

### MANITOBA

Air Rite, Inc.  
Winnipeg 204-895-2300

### NEW BRUNSWICK

EMR Services, Ltd.  
Moncton 506-855-4228

### ONTARIO

R.G. Henderson Ltd.  
Toronto 416-422-5580

Choquette - CKS, Inc.  
Ottawa 613-739-8458

### QUÉBEC

Choquette - CKS, Inc.  
Montreal 514-722-2000

Choquette - CKS, Inc.  
Québec City 418-681-3944

## UNITED KINGDOM

Marren Group  
Northants +44(0)1933 665313

**HATCO CORPORATION**  
P.O. Box 340500  
Milwaukee, WI 53234-0500 U.S.A.  
414-671-6350  
partsandservice@hatcocorp.com  
www.hatcocorp.com



24 Hour 7 Day Parts and Service  
Assistance available in the United States  
and Canada by calling 414-671-6350.