



OPERATING & SERVICE PARTS MANUAL  
**SCALEMATE OVERWRAPPER**



Model SM-1



Model SM-1 with Left Wing,  
Right Wing with Hood, and  
All purpose Shelf.



Model SM-1 with 12 Hour Timer,  
Right and Left wings, Printer  
Shelf and PS20 Label Dispenser

**READ ALL INSTRUCTIONS CAREFULLY BEFORE OPERATING EQUIPMENT**

# TABLE OF CONTENTS



Operating Instructions .....	3
Film Threading & Mounting .....	4
Recommended Maintenance .....	5
Scalemate Schematic & Parts List .....	6
Troubleshooting Guide .....	7
Electrical Service Information .....	8
Hot Plate Schematic & Parts List .....	9
Electrical Schematics & Replacement Instructions.....	10
Replacing the Fuse & Circuit Board.....	10
Replacing the Hot Rod .....	11
Replacing the Hot Plate Heating Element.....	12

# OPERATING INSTRUCTIONS



## OPERATION

First, mount and plug in any accessories you plan on using with your Scalemate. The accessory outlet is located midway up on the left side of the frame.

Next, plug your Scalemate wrapper into the appropriate power supply. The standard Scalemate wrapper utilizes a 115 volt AC power supply.

To turn on your Scalemate, flip the toggle switch on the left side of the wrapper to the "ON" position. The red indicator light will power on and remain on as long as the switch remains in the "ON" position.

Note: If your Scalemate has the factory option timer, see the instructions below for turning your machine on.

With the unit switched on, the hot plate and hot rod will begin to heat up to their set point temperatures. Once switched on, the unit should become operational in five-seven minutes.

## USING THE FACTORY OPTION TIMER

As a factory option, Scalemates can be ordered with a timer in lieu of the on/off toggle switch. Once set, the timer will begin to power the hot plate and hot rod until time runs out. To operate the timer, the dial must be turned past two hours in order for the unit to begin heating. When finished, the timer can be manually turned back to the off position.

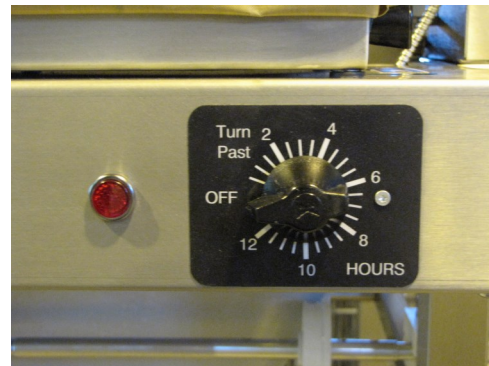

# FILM THREADING & MOUNTING



## THREADING THE FILM

Thread the film as shown, one at a time or as needed.

## FILM SELECTOR

Pull different sized films into film selector and drape unused film in front of roller.

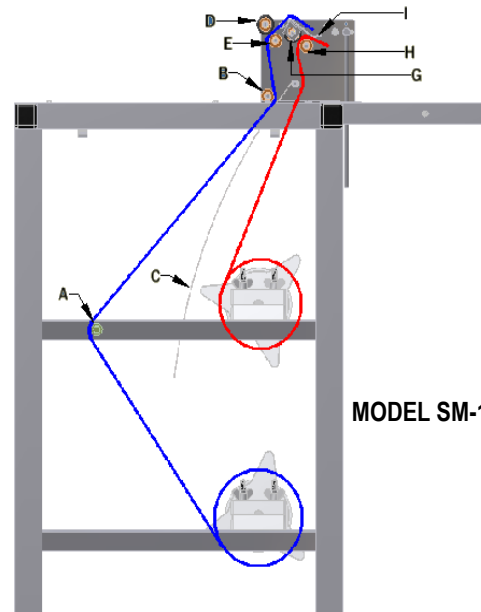

## MOUNTING FILM ON AXLE

1. Loosen four wing nuts (A)
2. Swing out upper bearing blocks (B) on both sides
3. Lift out axle assembly (C) and unscrew movable end cap (D), position fixed end cap (E) for correct film width then secure with pin (F) and o-ring (G)
4. Position the cardboard core of the film roll against the taper of the fixed end cap. Make sure the film is threaded from the bottom of the roll and under film roller (H) (see threading diagrams)
5. Replace adjustable end cap (D) and screw on tightly
6. Replace the axle assembly (C) and film roll onto the lower bearing blocks (J), swing upper bearing blocks (B) back into place and tighten and adjust wing nuts (A) for desired film tension

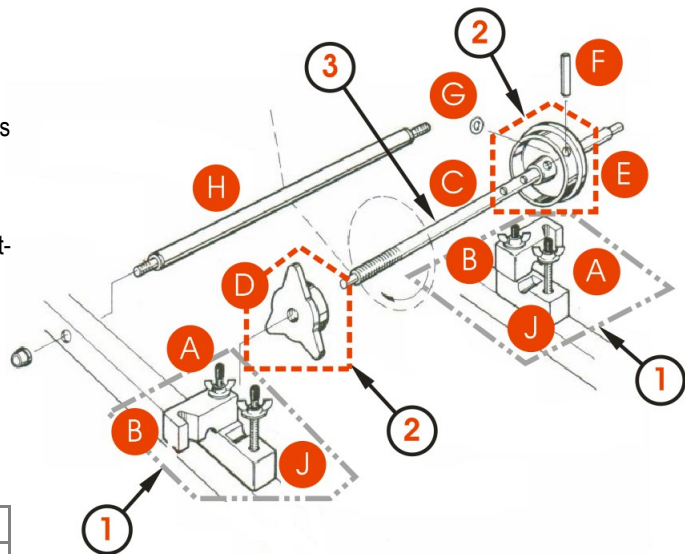

ITEM	PART #	DESCRIPTION
1	6305-018	Bearing Block Set, Includes: Upper Bearing Block, RH Upper Bearing Block, LH Lower Bearing Blocks
2	6110-023	3" Core Adapter Set Includes: 3" Adjustable Core 3" Fixed Core
3	3005-004	Core Axle, 21 15/16" L



- **MAKE SURE TO TURN OFF THE UNIT, PULL THE PLUG AND LET THE MACHINE COOL DOWN BEFORE CLEANING \***

## NON-STICK COVER & HOT PLATE

- It is recommended to replace the Non-stick cover at least once every three months to protect the heating foil and maintain a sanitary surface. The Non-stick cover is used to create a sanitary, stick free surface to seal film with the hot plate. Non-stick covers are porous, meaning liquids or moisture can permeate the cover, get to the surface of the hot plate, and burn off on the hot plate.
- It's recommended that the Non-stick cover be replaced every three (3) months or as needed depending on the level of daily wear and tear. The Non-stick cover should be changed if the surface is soiled, or holes, punctures, excessive wear, or damage are present.
- The hot plate can be cleaned, as needed, with a mild spray degreaser, applied to a soft rag or paper towel and then wiped on the plate while cold.

## CUT OFF ROD

- Make sure that the unit is turned off and the cut off rod is cold to the touch.
- The film cut off rod can be cleaned, as needed. Cover the unit surfaces with paper towels to protect them from over spray and debris.
- Spray and coat the Cut-off Rod generously with an FDA approved "Degreaser" product.
- After soaking for a few minutes, lightly scrub the surface of the Cut-off rod with a Scour Pad (Scotch-Brite™ type pad).
- Wipe the surface clean of debris and residue with clean paper towels or cloths.

## CLEANING THE UNIT

- The machine can be completely wiped down using mild cleaning detergent and soft rags or paper towels. Do not hose down or submerge the unit.

# SCALEMATE REPLACEMENT PARTS

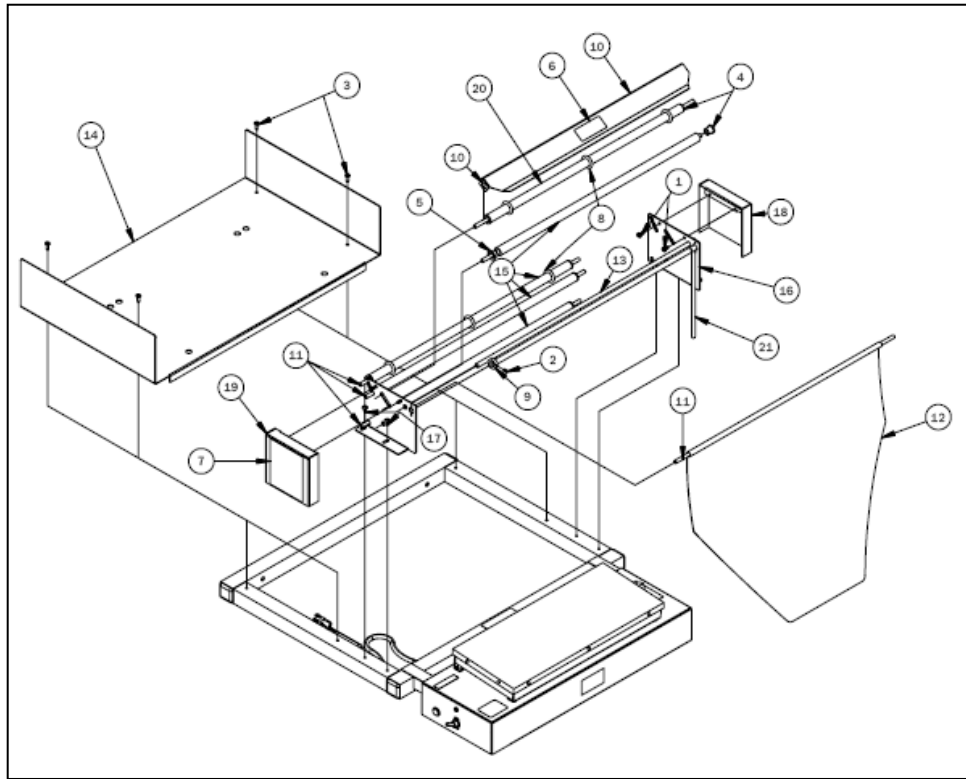

ITEM	QTY	PART #	DESCRIPTION
1	4	1903077	SCR, MACH, PAN HD, SLOT, SS, 8-32 X 3/8 LG.
2	1	1905021	SCR, SET, SOCKET, CUP PT, 8-32 X 1/4, BLACK
3	4	1905055	Screw, Self Tap, Type 23 8-32 x 1/2
4	5	<a href="#">2105009</a>	BEARING, FLANGE, NYLON, 5/16 ID. X 1/2 OD. X 1/2 LG.
5	6	<a href="#">2105057</a>	BEARING, FLANGED, BRONZE,
6	1	2150011	Decal, Film Tension Tightness
7	1	2150143	LABEL, THREADING DIAGRAM
8	6	<a href="#">2185002</a>	O RING, 5/8 ID X 13/16 OD
9	1	<a href="#">3005010</a>	Collar, Cutoff Rod, 3/4 OD x .390 ID, 1/4 THK, 8-32 Tap
10	1	<a href="#">6401020</a>	FLIPPER, FILM SELECTOR
11	6	<a href="#">6401021</a>	SHAFT, FILM SELECTOR/FILM
12	1	6401025	SEPARATOR, FILM - SCALEMATE
13	1	6401027	ROD, SEPERATOR, FILM
14	1	6401062	HOUSING, MOUNTING, SCALE
15	5	6401070	TUBE. FILM GUIDE - 20"
16	1	<a href="#">6401087</a>	Bracket, Tension Roller - Right
17	1	<a href="#">6401088</a>	Bracket, Tension Roller - Left
18	1	6401089	Cover, Bracket - Tension Roller, Right
19	1	6401090	Cover, Bracket - Tension Roller, Left
20	1	6401111	TUBE, FILM GUIDE - 5/8 X 19 3/8
21	1	<a href="#">1824018</a>	Hot Rod Heater

Revised 2017

## GENERAL QUESTIONS

If new machine doesn't turn on (heat up) what should we do?	Ensure power switch is ON. Check if fuse is blown. Check for loose wires in the electrical box, shipping may loosen wire connections.
My unit is tripping the GFCI?	The wires in the hot plate may be shorting and should be insulated with a high temperature electrical tape. If the thermostat is shorting to ground, replace the thermostat.
What is the standard voltage on wrapping machines?	110V - (220V is available)
Does the Heating Element 6110-016 fit all hot plates?	The element fits the 6 by 15, 8 by 15 and 9 by 12 hot plates. The 6 by 9 hot plate uses 6504-022 element.
My timer will not set for short amounts of time?	You must turn knob on the timer past 2 and set back to desired time.
How do I change my Non-stick cover?	When unit is cool, pull cover off it is not attached.
Where can I get transformers?	They are no longer available. You need a hot rod conversion kit.
What kind of film do I use?	PVC stretch film for wrapping meat and produce, its chemical characteristics provide barriers to protect the product. Stretch film for pallet wrap is Polyethylene and not to be used on wrappers.

## ABOUT HOT ROD

My hot rod is cold, what should I do?	<ul style="list-style-type: none"><li>a) Check the fuse, replace if blown.</li><li>b) Check the circuit board for loose wires.</li><li>c) See page 2 for testing the Hot Rod Circuit Board.</li></ul>
My hot rod is not hot enough or too hot, what should I do?	<ul style="list-style-type: none"><li>a) Check the circuit board, if potentiometer has been adjusted the rod will no longer work correctly.</li><li>b) See page 2 for testing the Hot Rod Circuit Board.</li></ul>
My hot plate works but my hot rod doesn't?	<ul style="list-style-type: none"><li>a) Hot Rod, Circuit Board and Fuse Holder work together.</li><li>b) Hot Plate, Thermostat and Element work together.</li><li>c) Hot Plate and Hot Rod are independent of each other.</li></ul>

## ABOUT HOT PLATE

Why is the Hot Plate smoking?	That is excess protective coating on the heating element burning off and should last no more than 10 or 15 minutes.
My hot plate is cold?	Check element then thermostat and wires to thermostat.

**\*\*WHEN REPLACING THE HOT ROD OR CIRCUIT BOARD,  
IT IS RECOMMENDED TO REPLACE BOTH SINCE THEY WORK TOGETHER.\*\***

## ELECTRICAL REQUIREMENTS

All Models are 110 Volts, 10 Amps.

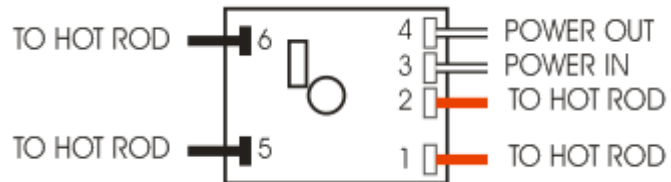

## HOT ROD CIRCUIT BOARD TEST

A standard 115 volt neon circuit tester can be used for these tests.

### CHECKING FUSES

Remove the fuse from their housing units located on the front of the electrical box. If a visual inspection does not verify a blown fuse check for continuity by using the meter to read across the two terminals of the fuse.

If the meter reading does not show continuity, replace the fuse.

### CHECKING THE HOT ROD

With the power turned OFF, remove the red hot rod wires from Terminals 1 and 2. Using the meter, measure the resistance of the rod by connecting the leads of the meter to the red wires.

The meter should read between 130-136 ohms. If the reading is out of this range, replace the hot rod.

### CHECKING THE CIRCUIT BOARD

After the hot rod and both the fuses have passed the above testing procedures, the circuit board can be tested.

With all the wires shown in the example circuit board (above) properly connected and the power ON, use the meter to test the voltage across Terminals 1 and 2. If there is no voltage being read, the board needs to be replaced.

**THIS UNIT SHOULD NOT BE OPERATED IF ROD TEMPERATURE EXCEEDS 300 DEGREES FAHRENHEIT. IF SMOKE OR FUMES ARE DETECTED, DISCONTINUE USE**

**WARNING: MAKE SURE THE MACHINE IS UNPLUGGED AND HEATING ELEMENTS ARE COOL BEFORE SERVICING.**

### ACCESSING ELECTRICAL COMPONENTS

The electrical components are located in the electrical enclosure below the hot plate. To access the components, unscrew the six screws (A) on the bottom of the electrical enclosure. With the screws removed the bottom panel (B) slides out to the left as shown.

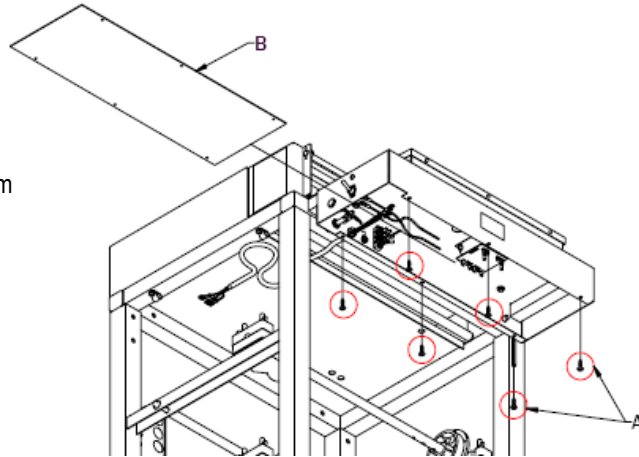

### HOT PLATE ASSEMBLY AND NON-STICK COVER

To replace a worn or torn non-stick cover, turn the machine off and let the hot plate and hot rod cool down. Once the hot plate and non-stick cover are cool, simply lift off the cover (it is not attached) and replace with a new one.

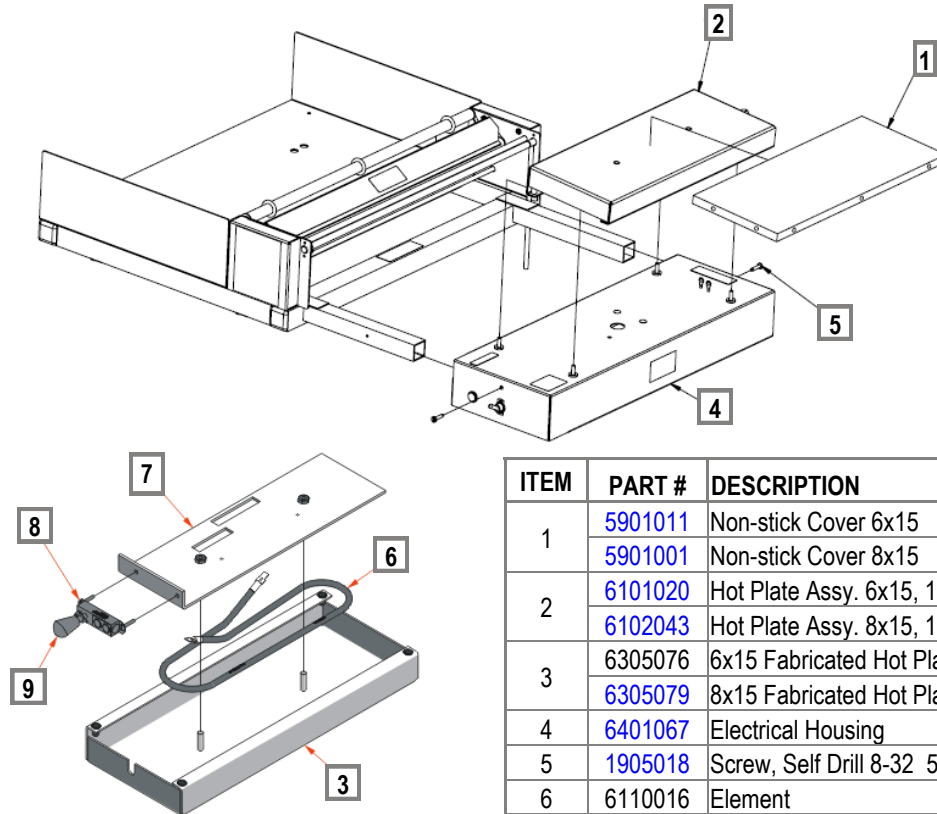

ITEM	PART #	DESCRIPTION
1	5901011	Non-stick Cover 6x15
	5901001	Non-stick Cover 8x15
2	6101020	Hot Plate Assy. 6x15, 115V STD
	6102043	Hot Plate Assy. 8x15, 115V STD
3	6305076	6x15 Fabricated Hot Plate
	6305079	8x15 Fabricated Hot Plate
4	6401067	Electrical Housing
5	1905018	Screw, Self Drill 8-32 5/8" Pan, Phil
6	6110016	Element
7	6305080	Element Support Plate
8	1881002	B-200 Thermostat
9	2145023	Knob

# ELECTRICAL DIAGRAM & CIRCUIT BOARD



ECN

## REPLACING THE FUSE

1. To replace the fuse, locate the fuse holder on the back left portion of the electrical enclosure next to the power cord.
2. Push in slightly and twist counter-clockwise until holder and fuse pop out.
3. Pull the fuse from the holder and insert a new fuse.
4. Insert the fuse holder and new fuse back into the mating portion on the electrical enclosure. Push in and twist clockwise to secure.

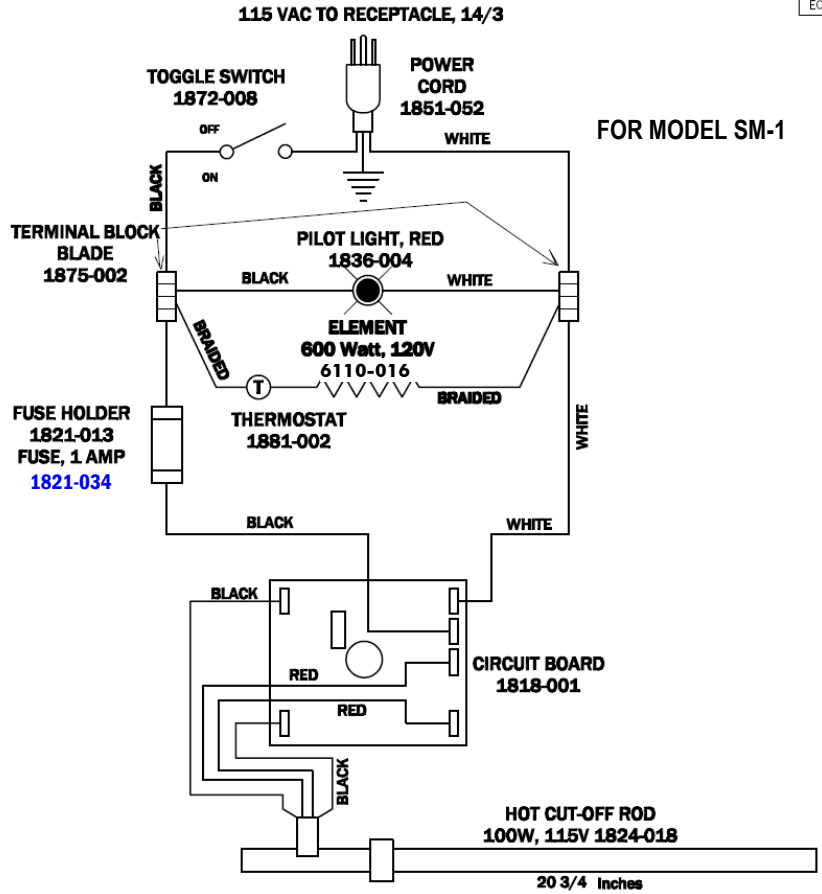

## REPLACING THE CIRCUIT BOARD

1. To replace the circuit board, unplug the machine and let the hot rod and hot plate cool down.
2. Once the hot rod and hot plate are cool, remove the access panel on the bottom of the electrical enclosure (See "Accessing Electrical Components").
3. With the panel removed, locate the circuit board and remove the wires at connection one, two, three, four, five, and six as pictured below. Mark each wire to remember what terminal it belongs on. Failure to reconnect the wires to the proper terminals can cause permanent damage to you machine.
4. Next, locate the four plastic pins (A,B,C,D) supporting the circuit board. Push in the tabs on the top of the plastic pins and pull the board off the posts.
5. Place the new circuit board over the four plastic standoffs and push down until the board snaps into place.
6. Reconnect the wires to the same terminals as on the old board. Verify you have connected the wire to the proper terminals by checking the pictures to the right.
7. Replace the bottom shielding on the electrical enclosure and screw tight.

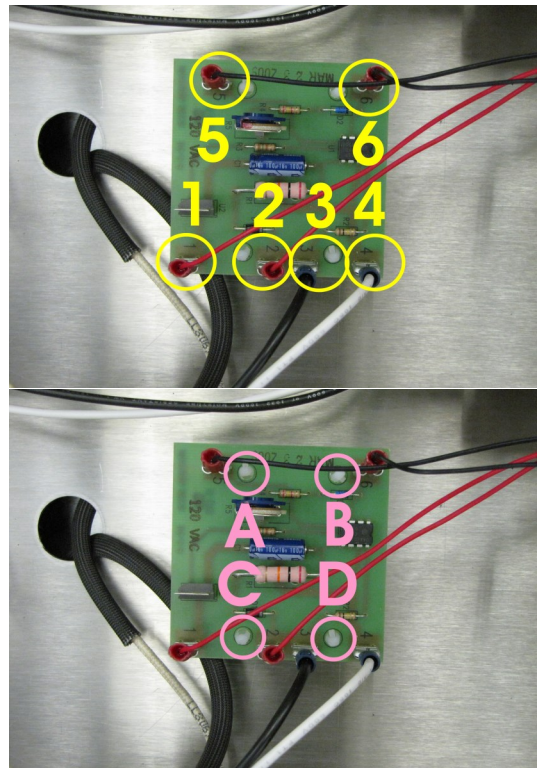

Revised 2017

# REPLACING THE HOT ROD



## REPLACING THE HOT ROD

Tools needed:

Medium Phillips Screwdriver

5/16 Allen Wrench

1. To replace the hot rod, unplug the machine and let the hot rod and hot plate cool down.
2. Once the hot rod is cool, remove the access panel on the bottom of the electrical enclosure (See "Accessing Electrical Components").
3. With the panel is removed, locate the circuit board and remove the wires at connection one, two, five, and six.
4. Next, loosen the set screw in the collar on the left side of the hot rod. Slide the collar over several inches to the right.
5. Slide the hot rod to the left to dislodge the end from the hole in the right side of the frame. Carefully feed the disconnected wires out of the electrical enclosure and slide the hot rod back to the right to remove it from the machine. If your repair requires you to replace the circuit board, go to "Replacing the Circuit Board" on page 8 before proceeding to step six.
6. With the collar set in the middle of the new hot rod, slide the new hot rod into the hole on the left side of the frame and then back into the right side of the frame.
7. Feed the wires (including the metal wire shielding) from the hot rod back into the electrical enclosure.
8. Connect the two black wires to terminals five and six on the circuit board, and connect the two red wires to terminals one and two.
9. Position the hot rod so the metal wire shielding is against the inside face on the right side of the frame and then slide the collar over to the inside face of the left side of the frame. Tighten the set screw
10. Replace the bottom shielding on the electrical enclosure and screw tight.

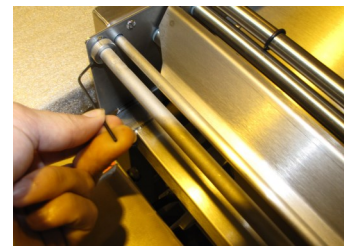
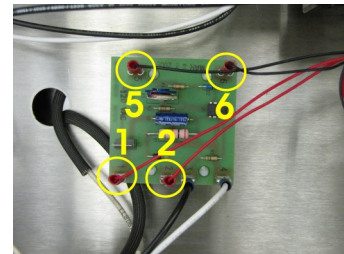

# REPLACING THE HOT PLATE ELEMENT



## REPLACING THE HOT PLATE HEATING ELEMENT

### Tools Needed

Medium Phillips Screwdriver

Medium Flathead Screwdriver

7/16 Wrench

1. To replace the hot rod, unplug the machine and let the hot rod and hot plate cool down.
2. Once the hot rod is cool, remove the access panel on the bottom of the electrical enclosure (See “Accessing Electrical Components”).
3. Disconnect from the terminal block the two wires with braided insulation that are coming down through the hole in the center of the enclosure.
4. Next, unscrew the four screws in the top of the electrical enclosure that attach the hot plate assembly. Note, if you have a Scalemate with the optional timer, the timer must be removed before you can access all the screws. To remove the timer, pull off the plastic knob in front and unscrew the screw on the face of the timer.
5. Once all four screws have been removed, carefully lift up on the on the hot plate assembly and remove it from the machine.
6. Turn the hot plate assembly upside down, pull back the black insulation, and disconnect the wires from the heating element.
7. Using a 7/16 wrench, unscrew the two nuts that are holding down the heating element retainer plate. With the nuts removed, flip up the retainer plate to expose the heating element.
8. Remove the old heating element and insert the new element underneath the retaining plate. Reattach the wire leads and secure the retainer plate with the bolts.
9. Place the hot plate assembly back on top of the enclosure and secure with the four screws. Attach the hot plate wire to the terminal blocks at their original location.
10. Replace the bottom shielding on the electrical enclosure and screw tight.

