



# HOSHIZAKI

---

## Instruction Manual

Steelheart Series  
Refrigerated Kitchen Equipment

Models  
Upright A-Series



[hoshizakiamerica.com](http://hoshizakiamerica.com)

Issued: 11-21-2019  
Revised: 2-6-2020

**⚠ WARNING**

Only qualified service technicians should install and service the appliance. To obtain the name and phone number of your local Hoshizaki Certified Service Representative, visit [www.hoshizaki.com](http://www.hoshizaki.com). No installation or service should be undertaken until the technician has thoroughly read this Instruction Manual. Likewise, the owner/manager should not proceed to operate the appliance until the installer has instructed them on its proper operation. Failure to install, operate, and maintain the appliance in accordance with this manual may adversely affect safety, performance, component life, and warranty coverage. Proper installation is the responsibility of the installer. Product failure or property damage due to improper installation is not covered under warranty.

Hoshizaki provides this manual primarily to assist qualified service technicians in the installation, maintenance, and service of the appliance.

Should the reader have any questions or concerns which have not been satisfactorily addressed, please call, send an e-mail message, or write to the Hoshizaki Technical Support Department for assistance.

Phone: 1-800-233-1940; (770) 487-2331

Fax: 1-800-843-1056; (770) 487-3360

E-mail: [techsupport@hoshizaki.com](mailto:techsupport@hoshizaki.com)

**HOSHIZAKI AMERICA, INC.**

618 Highway 74 South

Peachtree City, GA 30269

Attn: Hoshizaki Technical Support Department

Web Site: [www.hoshizaki.com](http://www.hoshizaki.com)

**NOTE:** To expedite assistance, all correspondence/communication **MUST** include the following information:

- Model Number \_\_\_\_\_
- Serial Number \_\_\_\_\_
- Complete and detailed explanation of the problem.

## ***IMPORTANT***

This manual should be read carefully before the appliance is installed and operated. Read the warnings and guidelines contained in this booklet carefully as they provide essential information for the continued safe use and maintenance of the appliance. Retain this booklet for any further reference that may be necessary.

## **CONTENTS**

Important Safety Information .....	4
I. Installation Instructions .....	7
A. Location .....	7
B. Checks Before Installation.....	8
C. Setup.....	9
D. DT1A-HS Heated Condensate Pan Installation.....	10
E. Food Cart Ramp (Roll-In/Roll-Thru Appliances).....	12
F. Door Reversal .....	14
1. Full Solid Door Reversal .....	14
2. Half Solid Door Reversal.....	17
3. Full Glass Door Reversal .....	22
4. Half Glass Door Reversal .....	27
G. Electrical Connection .....	33
H. Final Checklist.....	34
II. Operating Instructions.....	35
A. Important Notes About Usage .....	35
B. Startup .....	37
C. Controls and Adjustments .....	37
1. Temperature Display.....	37
2. Adjusting the Temperature Setpoint .....	38
3. Changing the Temperature Display Scale (°F or °C) .....	38
4. Light Control for Glass Door Models.....	38
D. Control Module Buttons and Icons .....	39
E. Defrost.....	40
F. Food Storage .....	41
G. Alarm Safeties.....	42
H. Safety Devices .....	43
I. Cooling Performance .....	43
J. Cabinet Condensation .....	43
III. Cleaning and Maintenance Instructions.....	44
A. Cleaning .....	44
B. Maintenance.....	45
IV. Preparing the Appliance for Periods of Non-Use .....	46
V. Disposal .....	47

## Important Safety Information

Throughout this manual, notices appear to bring your attention to situations which could result in death, serious injury, damage to the appliance, or damage to property.

<b>⚠ DANGER</b>	Indicates a hazardous situation that, if not avoided, will result in death or serious injury.
<b>⚠ WARNING</b>	Indicates a hazardous situation that, if not avoided, could result in death or serious injury.
<b>NOTICE</b>	Indicates a situation that, if not avoided, could result in damage to the appliance or property.
<b>IMPORTANT</b>	Indicates important information about the use and care of the appliance.

### **⚠ DANGER**

#### **Risk of Fire or Explosion**

##### **Flammable Refrigerant Used**

- Follow handling instructions carefully in compliance with U.S. government regulations.
- Do not use mechanical devices to defrost.
- Do not puncture refrigerant tubing. Risk of fire or explosion due to puncture of refrigerant tubing; follow handling instructions carefully.
- Component parts shall be replaced with like components.
- Servicing shall be done by factory authorized service personnel to minimize the risk of possible ignition due to incorrect parts or improper service.
- Consult instruction manual / service manual before attempting to install or service this product. All safety precautions must be followed.
- Dispose of properly in accordance with federal or local regulations.
- Do not place any potential ignition sources in or near the appliance.

### **Risque De Feu Ou D'Explosion**

#### **Le Frigorigène Est Inflammable**

- Suivre attentivement les instructions de manipulation conformément à la réglementation gouvernementale.
- Ne pas utiliser d'appareils mécaniques pour dégivrer le réfrigérateur.
- Ne pas perforer la tubulure contenant le frigorigène. Risque de feu ou d'explosion si la tubulure contenant le frigorigène est perforée; suivre les instructions de manutention avec soin.
- Les pièces des composants doivent être remplacées par des pièces et accessoires équivalents.
- L'entretien doit être effectué par le personnel de service autorisé par le fabricant afin de minimiser les risques d'inflammation attribuables à l'installation d'une pièce inadéquate ou à la mauvaise exécution du service.
- Consulter le manuel du propriétaire/ guide de réparation avant de tenter une réparation. Toutes les mesures de sécurité doivent être respectées.
- Éliminer conformément aux règlements fédéraux ou locaux.
- Ne placez aucune source d'inflammation potentielle dans ou près de l'appareil.

## **⚠ WARNING**


The appliance should be destined only to the use for which it has been expressly conceived. Any other use should be considered improper and therefore dangerous. The manufacturer cannot be held responsible for injury or damage resulting from improper, incorrect, and unreasonable use. Failure to install, operate, and maintain the appliance in accordance with this manual will adversely affect safety, performance, component life, and warranty coverage.

**To reduce the risk of death, electric shock, serious injury, or fire, follow basic precautions including the following:**

- Only qualified service technicians should install and service the appliance.
- Wear appropriate personal protective equipment (PPE) when servicing the appliance.
- The appliance must be installed in accordance with applicable national, state, and local codes and regulations.
- Appliance is heavy. Use care when lifting or positioning. Work in pairs when needed to prevent injury or damage.
- To reduce the risk of electric shock, do not touch the plug with damp hands.
- Unplug the appliance before servicing.
- The appliance requires an independent power supply of proper capacity. See the nameplate for electrical specifications. Failure to use an independent power supply of proper capacity can result in a tripped breaker, blown fuse, damage to existing wiring, or component failure. This could lead to heat generation or fire.

## **⚠ WARNING, continued**

### **• THE APPLIANCE MUST BE**

**GROUNDING.** The appliance is equipped with a NEMA 5-15 three-prong grounding plug  to reduce the risk of potential shock hazards. It must be plugged into a properly grounded, independent 3-prong wall outlet. If the outlet is a 2-prong outlet, it is your personal responsibility to have a qualified electrician replace it with a properly grounded, independent 3-prong wall outlet. Do not remove the ground prong from the power cord and do not use an adapter plug. Failure to follow these instructions may result in death, electric shock, or fire.

- Do not use an extension cord.
- Do not use an appliance with a damaged power cord. The power cord should not be altered, jerked, bundled, weighed down, pinched, or tangled. Such actions could result in electric shock or fire. To unplug the appliance, be sure to pull the plug, not the cord, and do not jerk the cord.
- The GREEN ground wire in the factory-installed power cord is connected to the appliance. If it becomes necessary to remove or replace the power cord, be sure to connect the power cord's ground wire.
- Do not splash, pour, or spray water directly onto or into the appliance. This might cause short circuit, electric shock, corrosion, or failure.
- Do not make any alterations to the appliance. Alterations could result in electric shock, injury, fire, or damage to the appliance.
- The appliance is not intended for use by persons (including children) with reduced physical, sensory, or mental capabilities, or lack of experience and knowledge, unless they have been given supervision or instruction concerning use of the appliance by a person responsible for their safety.

**⚠ WARNING, continued**

- Children should be properly supervised around the appliance.
- Do not climb, stand, or hang on the appliance or doors or allow children or animals to do so. Do not climb into the appliance or allow children or animals to do so. Death or serious injury could occur or the appliance could be damaged.
- Be careful not to pinch fingers when opening and closing the doors or when handling food pans. Be careful when opening and closing the doors when children are in the area.
- Open and close the doors with care. Opening the doors too quickly or forcefully may cause injury or damage to the appliance or surrounding equipment.
- Do not use combustible spray or place volatile or flammable substances in or near the appliance. They might catch fire.
- Keep the area around the appliance clean. Dirt, dust, or insects in the appliance could cause harm to individuals or damage to the equipment.
- Do not throw anything onto the shelves or load any single shelf with more than 120 lb. (54.5 kg) of product. They might fall off and cause injury.
- The appliance is designed only for temporary storage of food. Employ sanitary methods. Use for any other purposes (for example, storage of chemicals or medical supplies such as vaccine and serum) could cause deterioration of stored items.
- Do not place any product on the floor of the cabinet. All product must be placed on properly installed shelves.
- Do not block air inlets or outlets, otherwise cooling performance may be reduced.
- Do not tightly pack the cabinet. Allow some space between items to ensure good air flow. Also allow space between items and interior surfaces.

**⚠ WARNING, continued**

- Do not put warm or hot foods in the cabinet. Let them cool first, or they will raise the cabinet temperature and could deteriorate other foods in the cabinet or overload the appliance.
- Food storage and handling must comply with applicable codes and regulations.
- All foods should be wrapped in plastic film or stored in sealed containers. Otherwise foods may dry up, pass their smells onto other foods, cause frost to develop, result in poor appliance performance, or increase the likelihood of cross-contamination. Certain dressings and food ingredients, if not stored in sealed containers, may accelerate corrosion of the evaporator, resulting in failure.
- Do not store items near air outlets. Otherwise, items may freeze up and crack or break causing a risk of injury or contamination of other food.
- Do not place more than 20 lb. (9 kg) on the top panel. Items must be stable and secure to prevent items from falling off of the appliance.
- Care should be used when placing items on top of the appliance. Do not store liquid containers or items that could fall through the louvers on top of the appliance. This could cause electric shock or fire.

**NOTICE**

- Protect the floor when moving the appliance to prevent damage to the floor.
- Keep ventilation openings, in the appliance enclosure or in the built-in structure, clear of obstruction.
- Do not allow the appliance to bear any outside weight.
- To prevent deformation or cracks, do not spray insecticide onto the plastic parts or let them come into contact with oil.
- To avoid damage to the gasket, use only the door handle when opening and closing.

## I. Installation Instructions

### **⚠ WARNING**

- This appliance must be installed in accordance with all applicable national, state, and local regulations.
- Appliance is heavy. Use care when lifting or positioning. Work in pairs when needed to prevent injury or damage.
- Do not tilt the appliance more than 45°.

## A. Location

### **⚠ WARNING**

- This appliance is not intended for outdoor use.
- Normal operating ambient temperature:
  - Refrigerators and Solid Door Freezers 45°F to 100°F (7°C to 38°C)
  - Glass Door Freezers 45°F to 80°F (7°C to 27°C)
 Operation of the appliance, for extended periods, outside of this normal temperature range may affect appliance performance.

For best operating results:

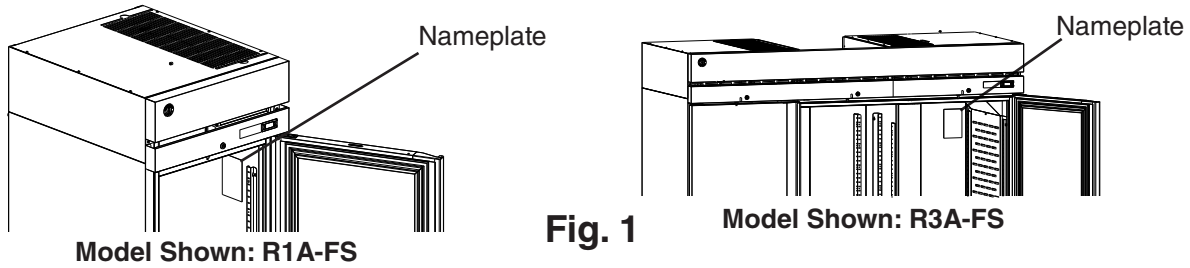
- The appliance should not be located next to ovens, grills, or other high heat producing equipment.
- The location should provide a firm and level foundation for the appliance.
- The appliance should not be located in a corrosive environment.
- Minimum Clearance:

<b>Models</b>	<b>Side</b>	<b>Top</b>	<b>Rear</b>
Reach-In Refrigerators and Freezers (Except Roll-In's, Roll-Thru's, Pass-Thru's, and 2-Section Freezers)	0" (0 cm)	0" (0 cm)	3" (8 cm)
Reach-In Refrigerators Roll-In's	0" (0 cm)	10" (25 cm)	0" (0 cm)
Reach-In Refrigerators Roll-Thru's and Pass-Thru's	0" (0 cm)	0" (0 cm)	N/A
2-Section Freezers	0" (0 cm)	10" (25 cm)	3" (8 cm)

## B. Checks Before Installation

### **⚠ WARNING**

Refer to the nameplate for electrical specifications. The nameplate is located on the right side wall of the 1 and 2 section cabinet interior and the rear wall of the 3 section cabinet interior. For more electrical connection details, see "I.G. Electrical Connection." We reserve the right to make specification and design changes without prior notice.



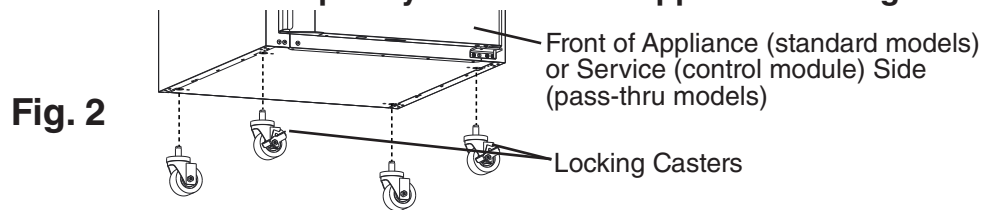
- Visually inspect the exterior of the shipping package and immediately report any damage to the carrier. Upon opening the package, any concealed damage should also be immediately reported to the carrier.
- Remove the shipping carton, tape, and packing material. Remove the protective plastic film from the exterior panels on all models and from the interior door panels on solid door models. If the appliance is exposed to the sun or to heat, remove the film after the appliance cools.
- Remove all accessory containers before discarding the packing materials. Dispose of all packing materials in a proper and environmentally responsible manner.
- Check for missing or damaged accessories.

## C. Setup

### 1. Caster or Optional 6 in. Leg Installation and Leveling the Appliance

#### a) Caster or Optional 6 in. Leg Installation

- 1) Move as close to the final location as possible.
- 2) Remove the 2 bolts securing the appliance to the pallet, then remove the appliance from the pallet. Block the appliance securely at a height of 8" (20 cm) off the floor. Do not lay the appliance down. **NOTICE! Do not allow the door(s) to bear the weight of the appliance.**
  - a) Casters: Attach and tighten the casters to the bottom of the appliance. Locking casters should be attached to the front of the appliance for standard models and on the service (control module) side on pass-thru models. See Fig. 2.  
**NOTICE! Ensure casters are completely threaded into appliance and tight.**



- b) Legs: Optional 6 in. legs available. Attach and tighten the optional adjustable 6 in. legs to the bottom of the appliance.

### ⚠ WARNING

When using legs, avoid sliding the appliance across the floor after legs are installed.

#### b) Leveling the Appliance

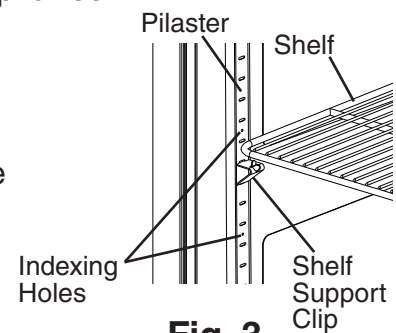
After installing the casters or optional 6 in. legs, lower the appliance to the floor and check the level of the appliance.

- a) Casters: If the appliance is out of level, follow the instructions and steps found in [HS-3590](#) provided in the accessories bag. Otherwise, continue to the next section.  
**NOTICE! Make sure the casters are tight and no slack is left between the casters, shim plates, and appliance.**
- b) Legs: If the appliance is out of level, turn the bottom portion of the leg for height adjustment. Otherwise, continue to the next section. **NOTICE! Make sure the legs are tight and no slack is left between the leg and appliance.**

## 2. Install the Shelves

Shelf support clips are provided in the accessory pack.

- 1) Place the shelf support clips into the pilasters (4 shelf support clips per shelf). Indexing holes are provided on the pilasters in evenly spaced intervals to assist in positioning the support clips at the same height. See Fig. 3.
- 2) Place the shelves in position on the shelf support clips.



## 3. Check the Refrigeration Circuit

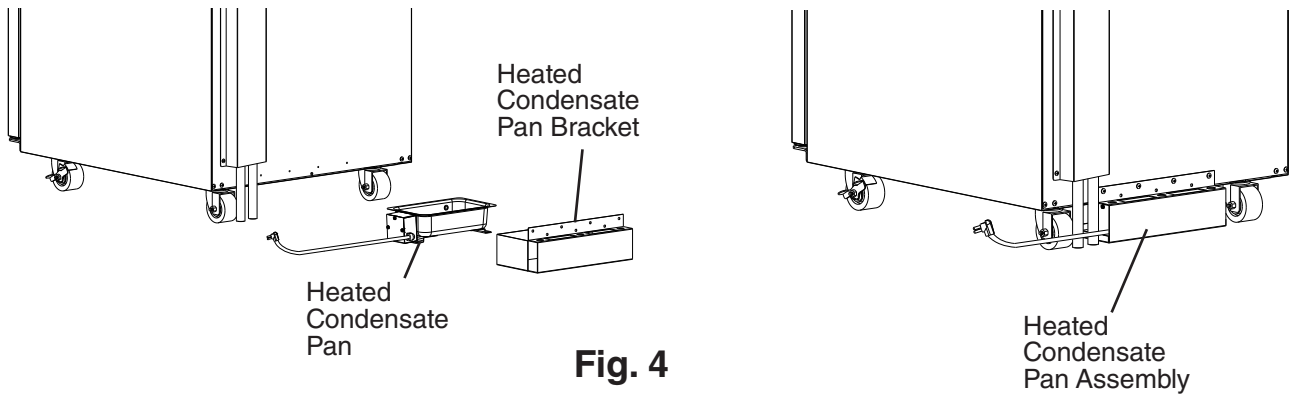
- 1) Visually check that the refrigerant lines do not rub or touch other lines or surfaces and that the condenser fan blade turns freely.
- 2) Check that the compressor is snug on all mounting pads.

## D. DT1A-HS Heated Condensate Pan Installation

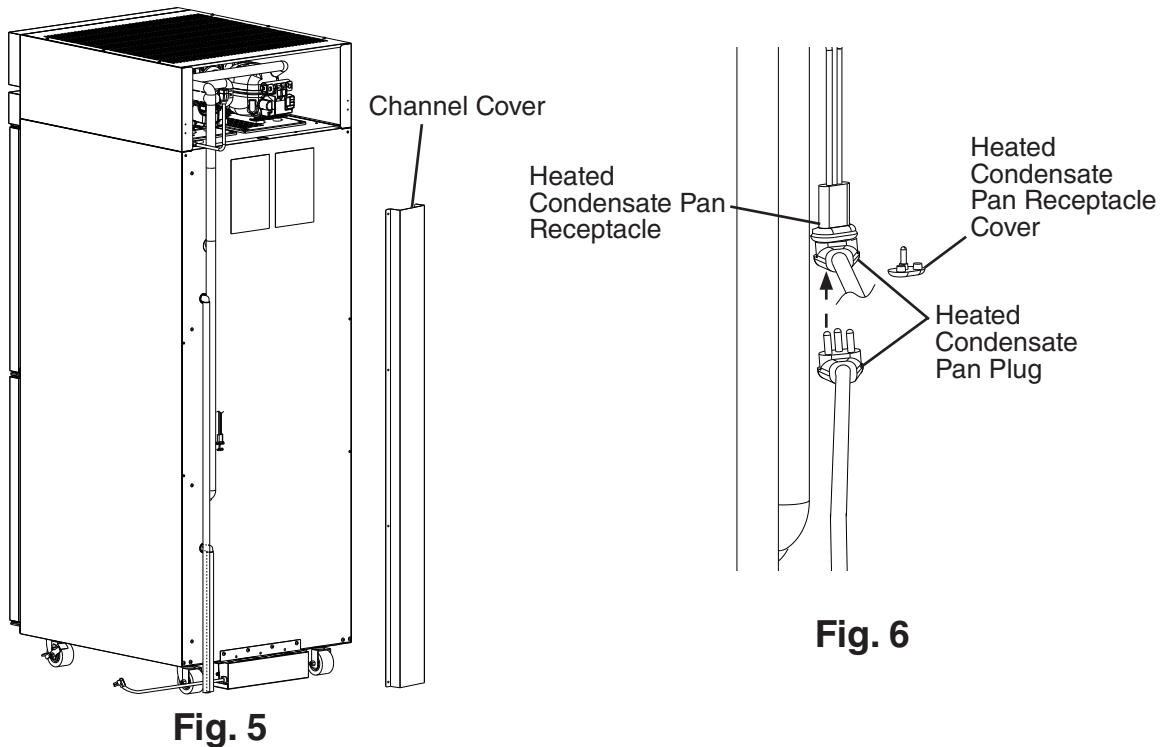
### **⚠ WARNING**

Failure to install the heated condensate pan in accordance with this manual could adversely affect safety and result in costly water damage.

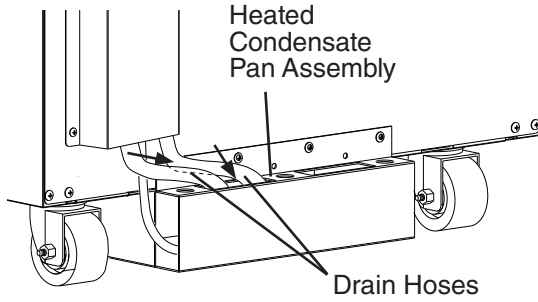
- 1) Remove the heated condensate pan and heated condensate pan bracket from the accessory bag.
- 2) Place the heated condensate pan in the heated condensate pan bracket, then using the 4 screws provided in the accessory bag, secure the heated condensate pan bracket to the rear of the appliance. See Fig. 4.



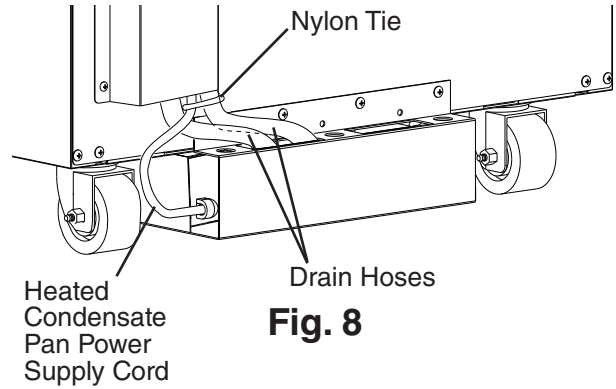
- 3) Remove the channel cover from the back of the appliance. See Fig. 5.
- 4) Remove the heated condensate pan receptacle cover from the heated condensate pan receptacle. Next, plug the heated condensate pan plug into the heated condensate pan receptacle. See Fig. 6.



- 5) Replace the channel cover in its correct position.
- 6) Route the drain hoses into the heated condensate pan assembly. See Fig. 7.  
**Warning! Confirm that the drain hoses does not contact the heater. Adjust as necessary.**
- 7) Using a nylon tie from the accessory bag, secure the heated condensate pan power supply cord to one of the drain hoses. See Fig. 8.
- 8) Place the appliance in its final location.



**Fig. 7**



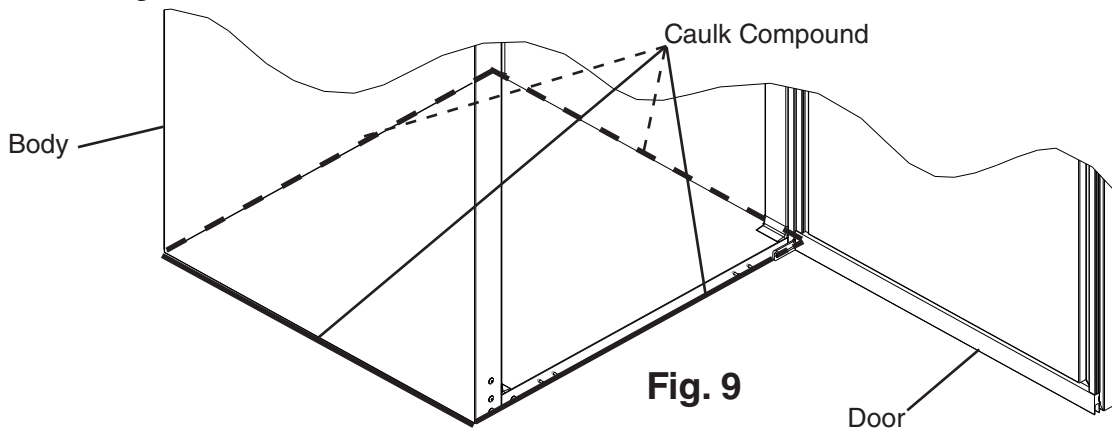
**Fig. 8**

## E. Food Cart Ramp (Roll-In/Roll-Thru Appliances)

Confirm the area where the appliance is to be installed is flat and level.

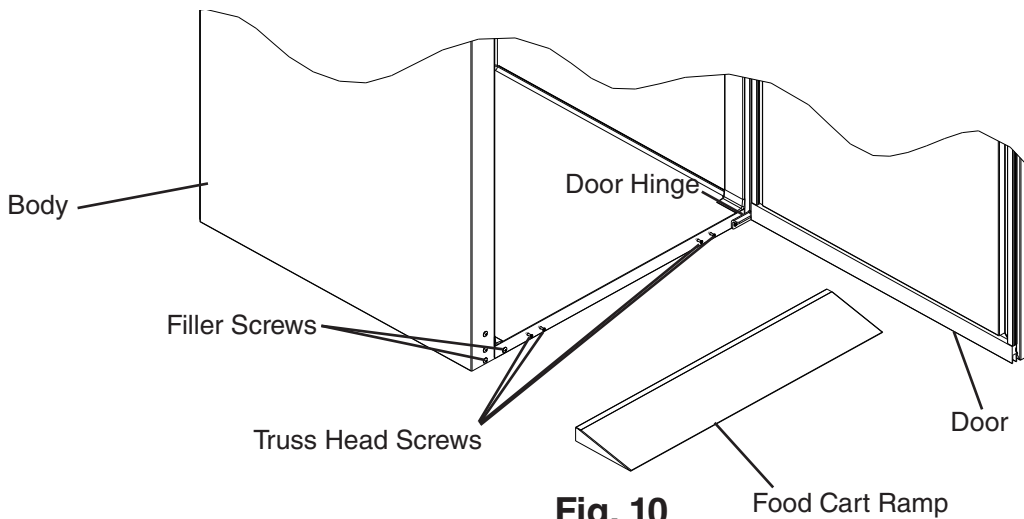
- 1) Place the appliance in position, then seal the perimeter where the appliance contacts the floor with approved caulk compound in a smooth and easily cleanable manner.

See Fig. 9.



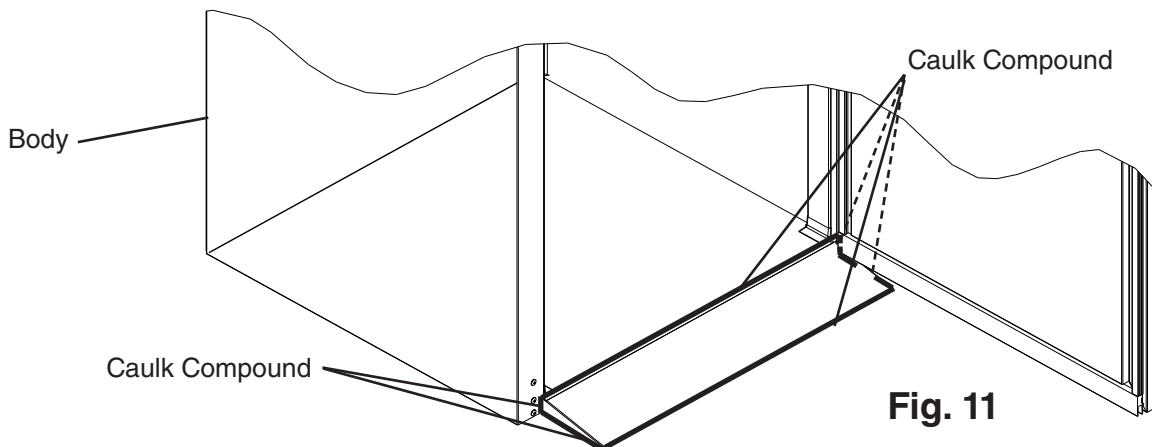
**Fig. 9**

- 2) Remove the 2 filler screws from the bottom of the appliance. See Fig. 10. Next, loosen the 4 truss head screws at the bottom of the appliance 3 to 4 mm (1/8"), then lay the ramp onto the loosened truss head screws. See Fig. 10.



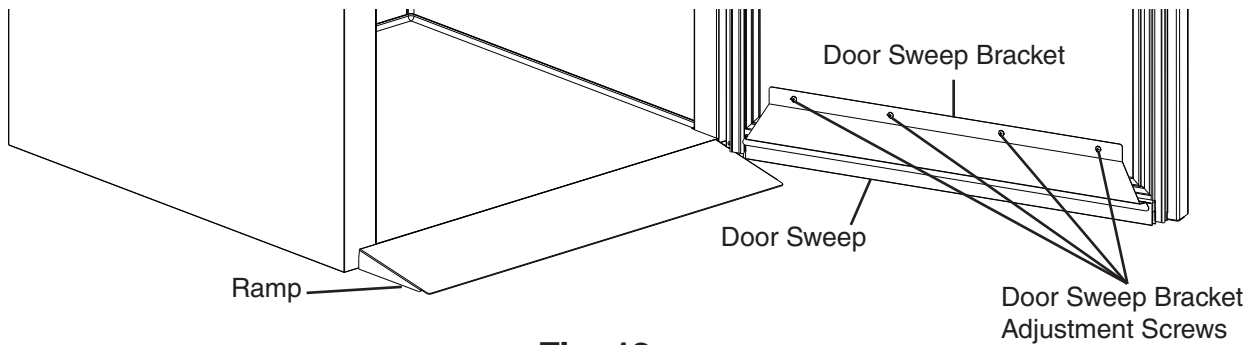
**Fig. 10**

- 3) Seal around the ramp as shown in Fig. 11 with an approved caulk compound.



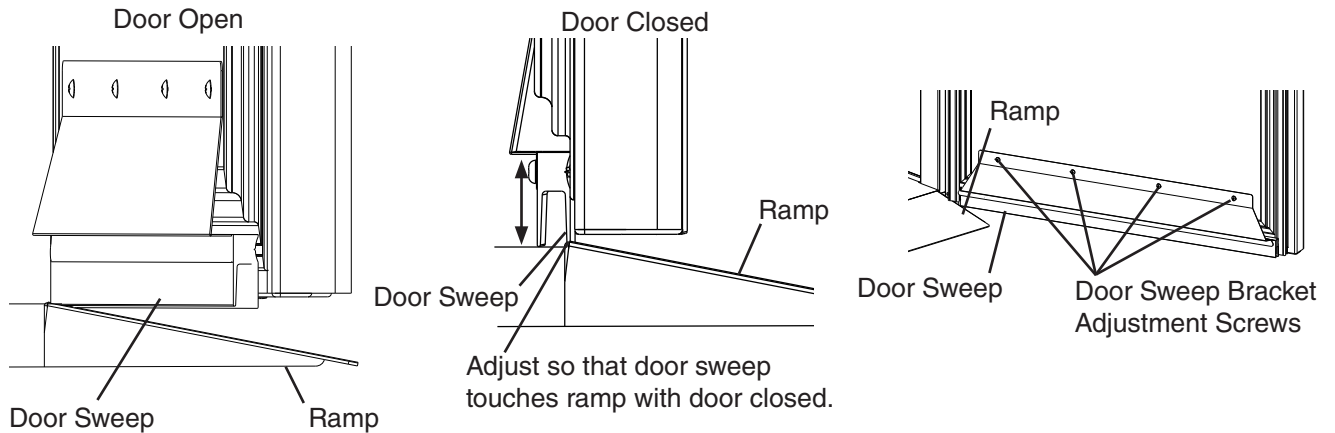
**Fig. 11**

4) Loosen the door sweep bracket adjustment screws. See Fig. 12.



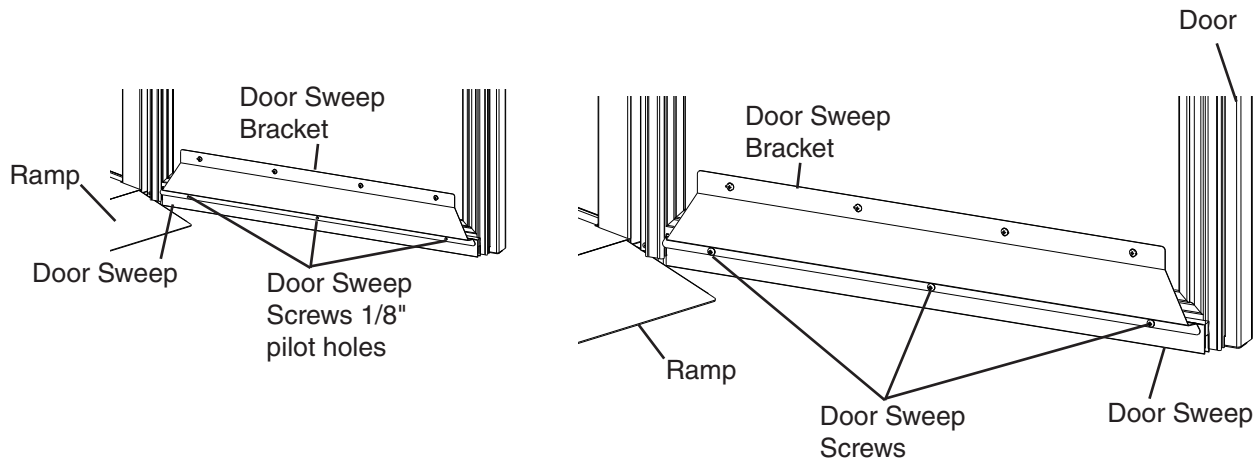
**Fig. 12**

5) Adjust the door sweep so that the door sweep touches the ramp when the door is closed. See Fig. 13. Once in its correct position, tighten the door sweep bracket adjustment screws.



**Fig. 13**

6) Drill three 1/8" pilot holes in the positions shown in Fig. 14. Use the 3 screws provided in the accessory bag to secure the door sweep to the door sweep bracket and the door.



**Fig. 14**

## F. Door Reversal

This appliance is provided with a cabinet design which, after being delivered to the installation location, permits changing of the door swing from left to right or right to left.

### ⚠ WARNING

- Wear proper PPE (personal protection equipment) when executing these procedures (safety glasses and gloves).
- Keep fingers away from edge of upper hinge bracket. Spring cartridge can cause the upper hinge bracket to move suddenly with extreme force.

### 1. Full Solid Door Reversal

Note: Hinge brackets, and spring cartridge are universal and can be used in both left and right-hinged applications.

Example shows change from right hinged to left hinged.

- 1) Lock the casters.
- 2) Remove the front panel, then being careful not to pull the wires on the control module and door switch(es), remove the control panel. Secure the control panel so that it does not interfere with the hinge bracket and will not fall. See Fig. 15.

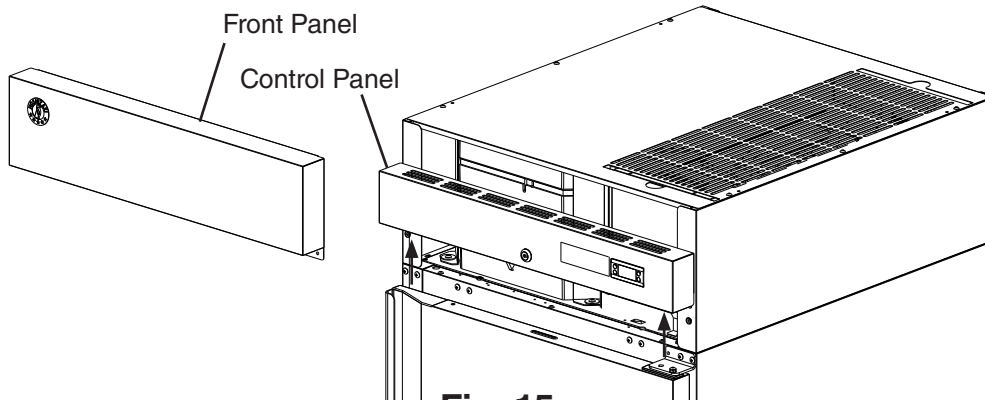


Fig. 15

- 3) While maintaining a hold on the door, remove the upper hinge bracket, then lift the door up off the bottom hinge and set aside. See Fig. 16. Remove the filler screws from the opposite side upper hinge bracket holes and mount them into the holes of the removed upper hinge bracket. **NOTICE! Be sure to reuse the bracket screws for mounting the bracket as the bracket screws are 5x12 and filler screws are 5x10.**

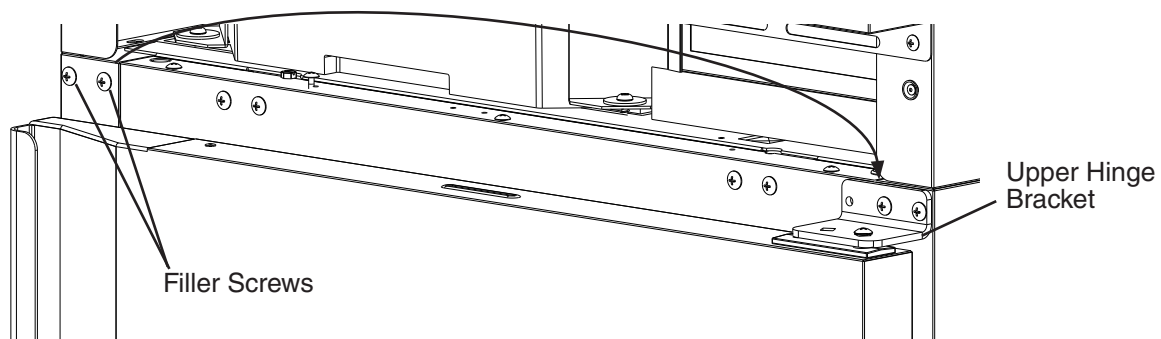
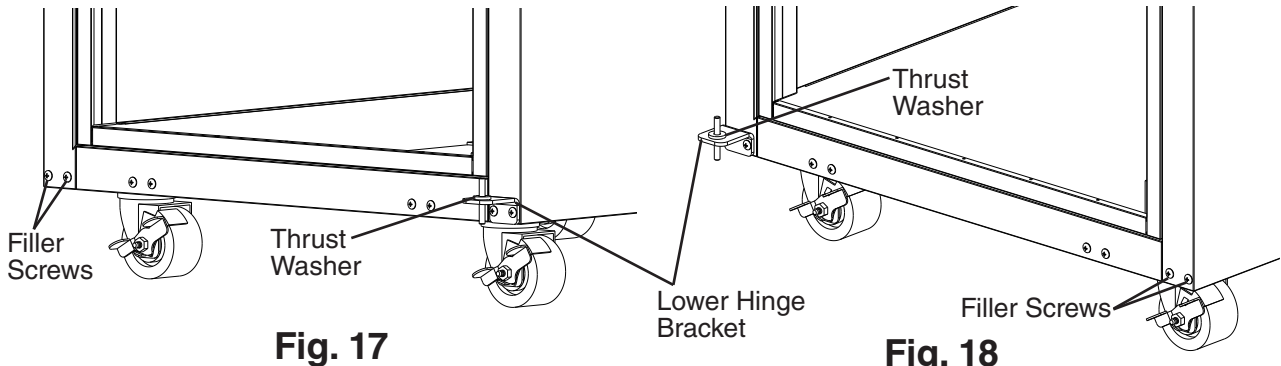
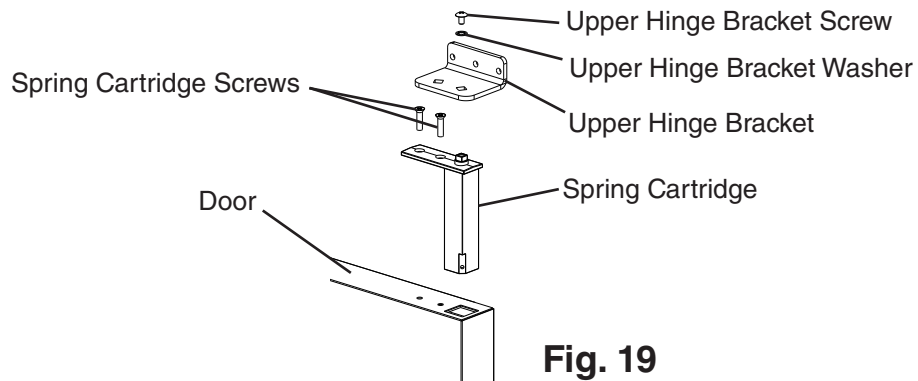


Fig. 16

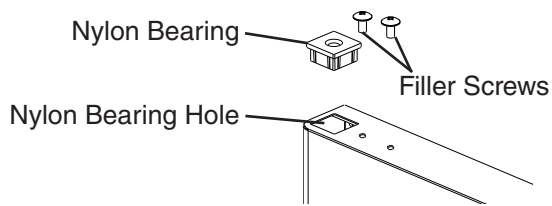
- 4) Remove the lower hinge bracket and thrust washer. See Fig. 17. Retain thrust washer for opposite side lower hinge bracket installation. Remove the filler screws from the opposite side lower hinge bracket holes and mount them into the holes of the removed lower hinge bracket. **NOTICE! Be sure to reuse the bracket screws for mounting the bracket as the bracket screws are 5x12 and filler screws are 5x10.**
- 5) Secure the lower hinge bracket to the opposite side lower hinge bracket location, then place the thrust-washer on the lower hinge bracket. See Fig. 18.



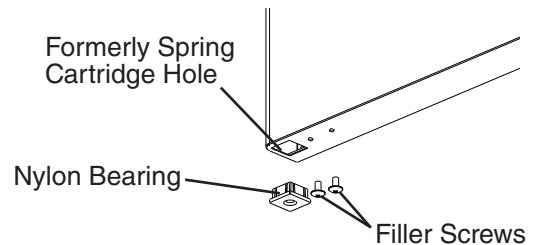
- 6) Remove the screw and washer securing the upper hinge bracket to the spring cartridge. Remove the 2 screws securing the spring cartridge to the door, then remove the spring cartridge from the door. See Fig. 19.



- 7) Rotate the door 180 degrees, to its new orientation. Remove the nylon bearing and filler screws. See Fig. 20. **NOTICE! Care should be taken not to damage the door.** Mount the nylon bearing and filler screws into the holes left by the spring cartridge in the lower section of the door. See Fig. 21.

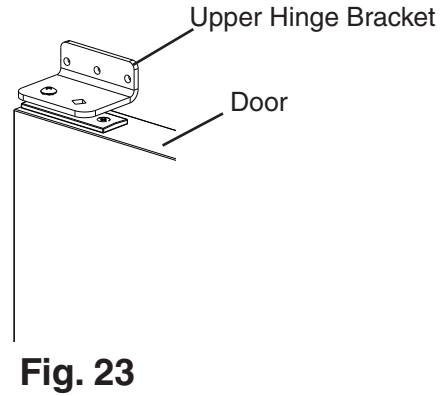
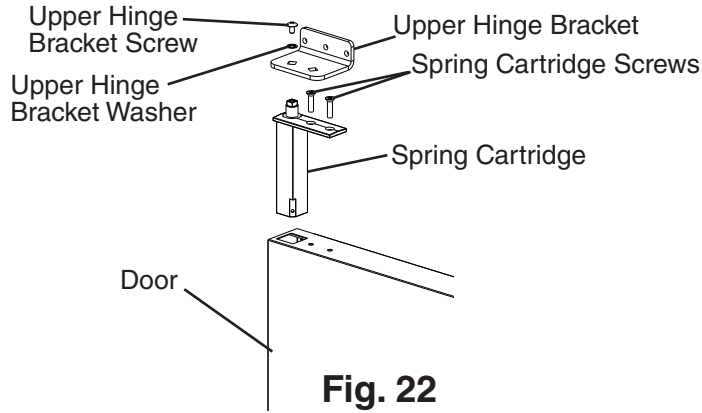


**Fig. 20**



**Fig. 21**

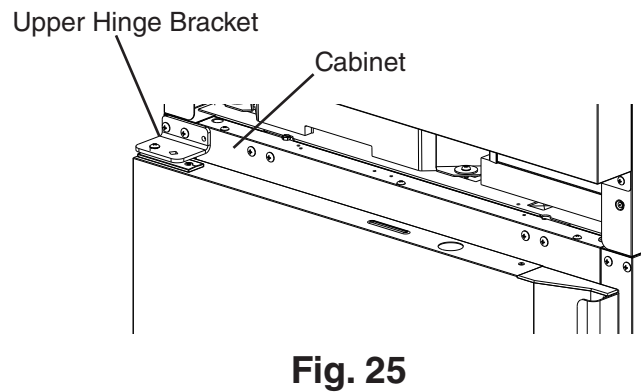
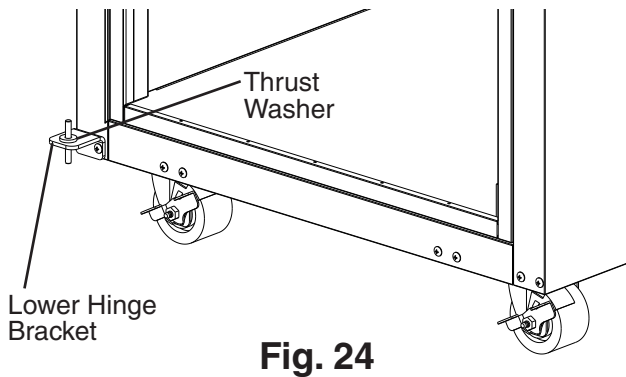
- 8) Clear foam from the spring cartridge hole to allow for spring cartridge installation. Install the spring cartridge and secure it to the door using the spring cartridge screws removed in step 6. See Fig. 22. Next, align the upper hinge bracket to the door in the orientation that allows for closed door installation. See Fig. 23. Secure the upper hinge bracket to the door using the screw and washer removed in step 6.



- 9) Make sure the thrust washer is in place, then mount the door onto the lower hinge bracket (nylon bearing over lower hinge bracket pin). See Fig. 24.

- 10) Secure the upper hinge bracket to the appliance. See Fig. 25.

- 11) Verify swing. Move the control panel hole plugs to the other side, then replace and secure the control panel and front panel in their correct positions. Verify the door switch and lock function.

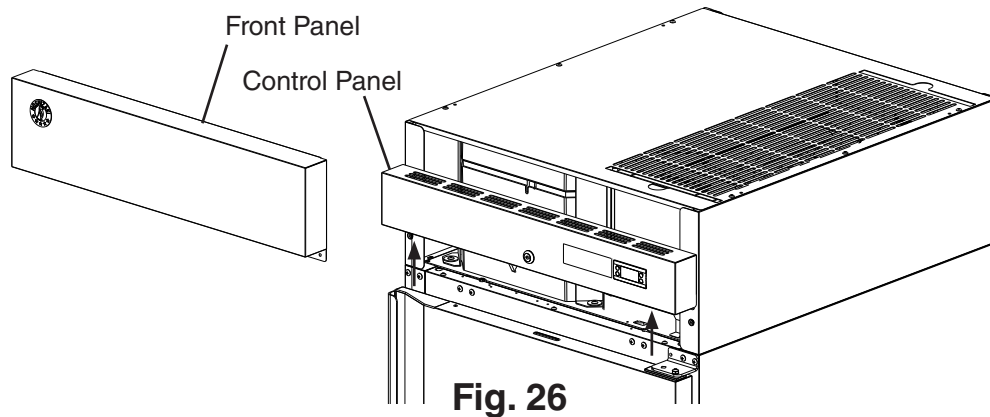


## 2. Half Solid Door Reversal

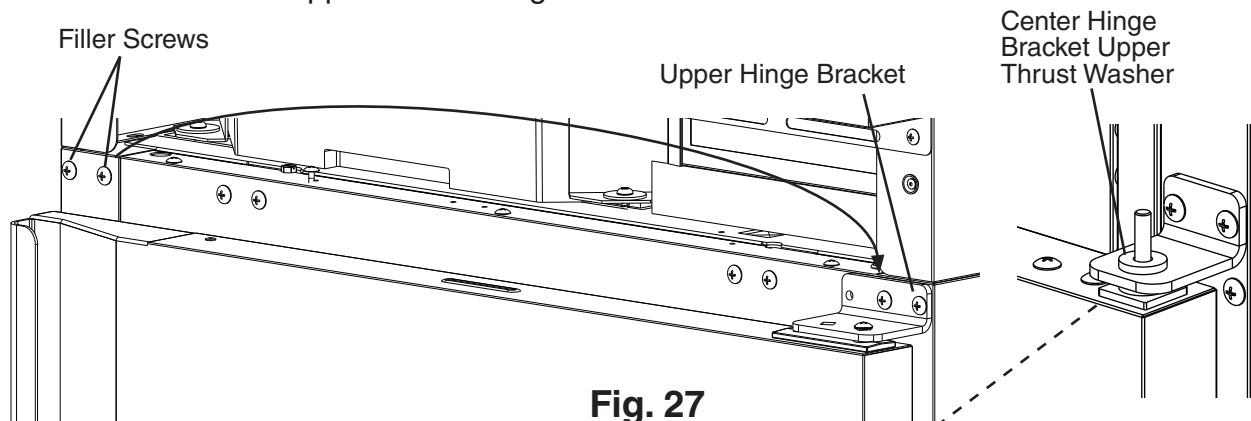
Note: Hinge brackets, and spring cartridge are universal and can be used in both left and right-hinged applications.

Example shows change from right hinged to left hinged.

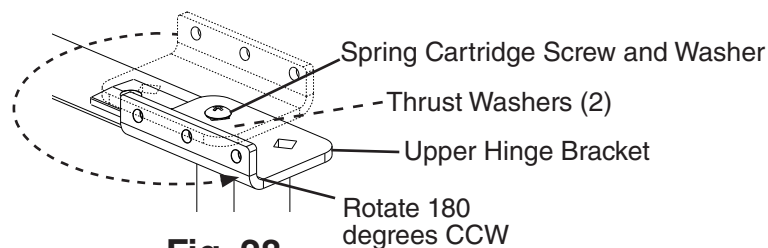
- 1) Lock the casters.
- 2) Remove the front panel, then being careful not to pull the wires on the control module and door switch(es), remove the control panel. Secure the control panel so that it does not interfere with the hinge bracket and will not fall. See Fig. 26.



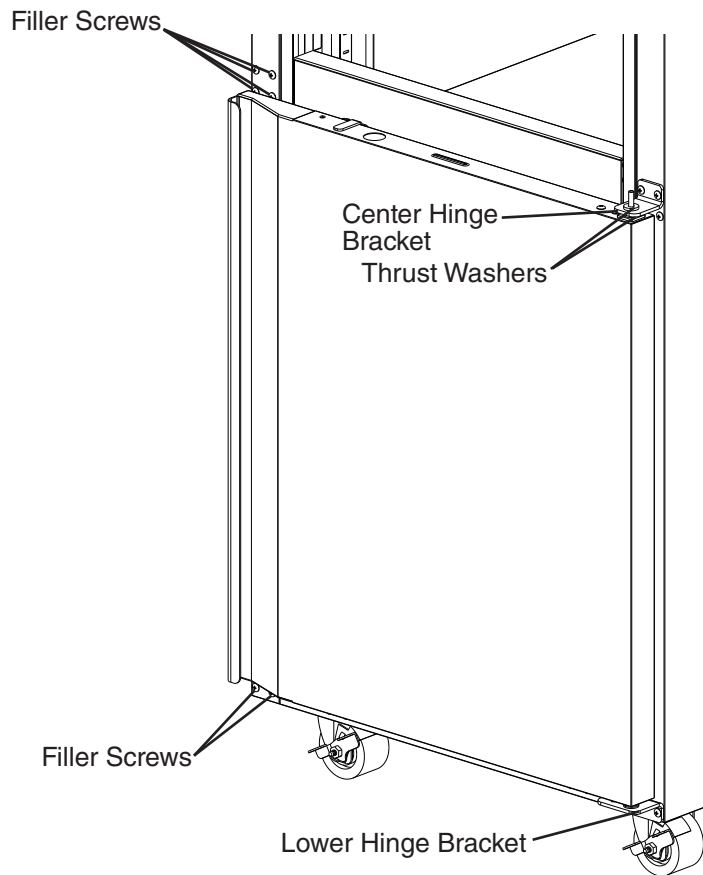
- 3) While maintaining a hold on the upper door, remove the upper hinge bracket then lift the door off the center hinge bracket. See Fig. 27. Retain the upper center hinge bracket thrust-washer for opposite side hinge bracket installation.



- 4) Rotate the upper hinge bracket 180 degrees counter clockwise. See Fig. 28. Next, remove the spring cartridge screw and washer, then remove the upper hinge bracket and thrust washers (2). Set the door aside. Retain the upper hinge bracket thrust washers for opposite side hinge bracket installation.

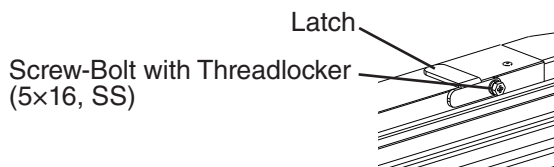


- 5) Remove the filler screws from the opposite side upper hinge bracket holes and mount them into the holes of the removed upper hinge bracket. **NOTICE! Be sure to reuse the hinge bracket screws for mounting the hinge bracket as the hinge bracket screws are 5×12 and filler screws are 5×10.**
- 6) While maintaining a hold on the lower door, remove the lower hinge bracket from the cabinet, then lower the door off the center hinge bracket and set aside. See Fig. 29. Retain the center hinge thrust washers for opposite side installation.
- 7) Remove the center hinge bracket from the cabinet. Remove the filler screws from the opposite side lower and center hinge bracket holes and mount them into the holes of the removed lower and center hinge brackets. **NOTICE! Be sure to reuse the hinge bracket screws for mounting the hinge brackets as the hinge bracket screws are 5×12 and filler screws are 5×10.**



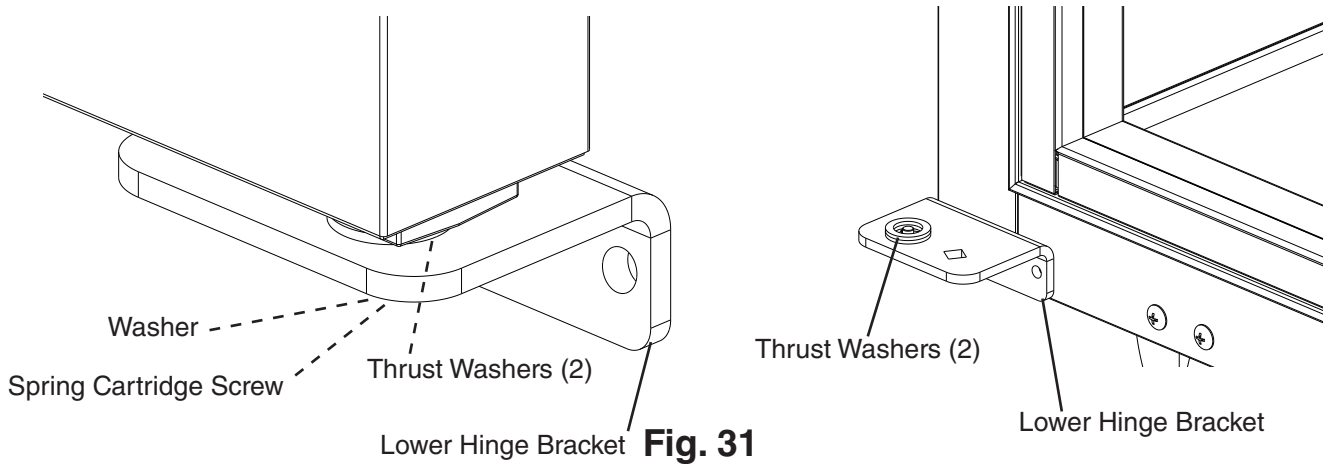
**Fig. 29**

- 8) Remove the door latch from the lower door. See Fig. 30.

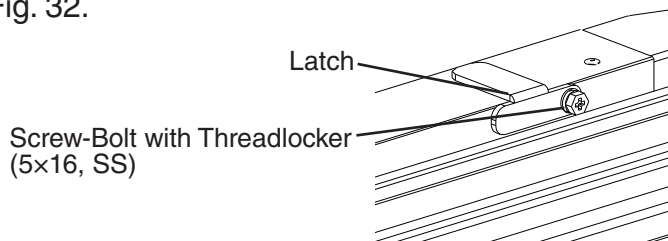


**Fig. 30**

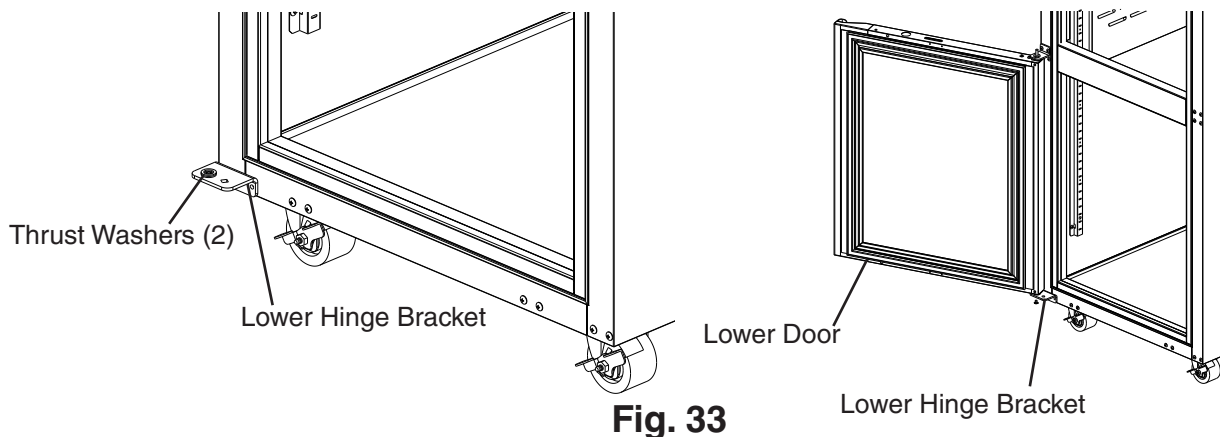
- 9) Remove the lower hinge bracket spring cartridge screw, washer, and thrust washers from the door. Set the door aside. Next, secure the lower hinge bracket to the opposite side. Make sure the lower thrust-washers are in place. See Fig. 31.



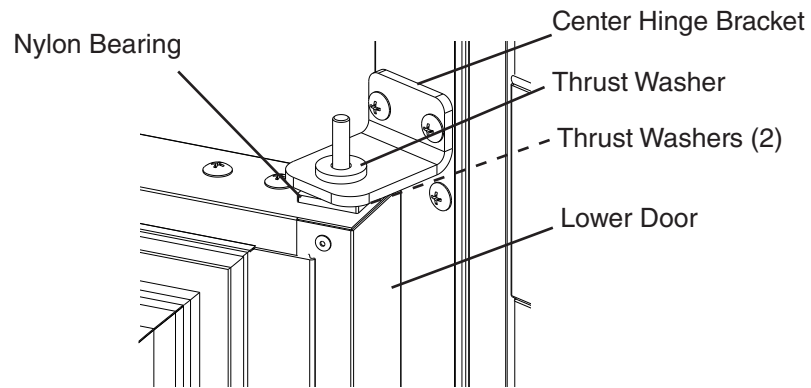
- 10) Rotate the former upper door 180 degrees to its new lower door orientation.  
**NOTICE! Care should be taken not to damage the door.**
- 11) Attach the lower door latch to the newly rotated lower door (former upper door).  
See Fig. 32.



- 12) Make sure the lower hinge bracket thrust washers (2) are in place, then with the lower door (rotated upper door) in the *maximum* open position, place the door onto the lower hinge bracket. See Fig. 33.  
The spring cartridge shaft should slide into the lower hinge bracket and be flush with the bottom of the lower hinge bracket.

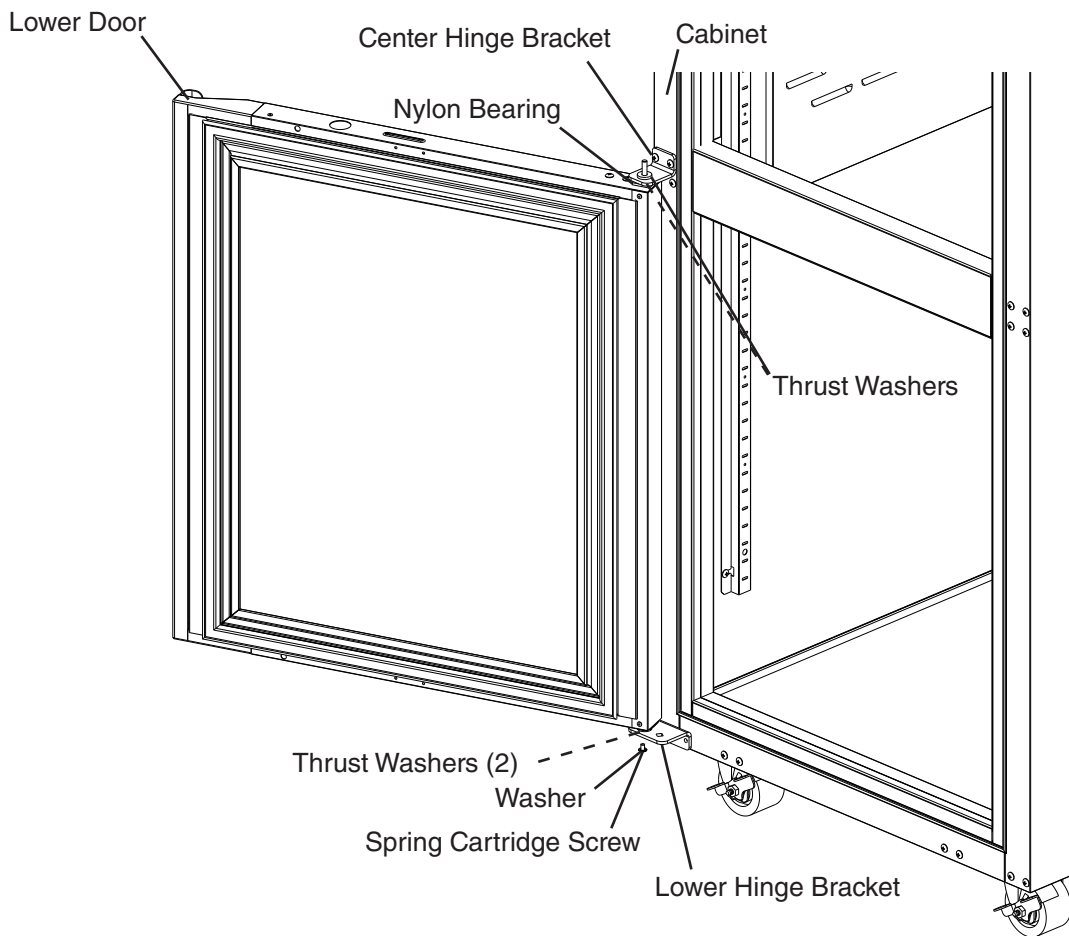


- 13) Place the center hinge bracket lower pin with thrust washer into the nylon bearing on top of the door. Secure the center hinge bracket to the cabinet. See Fig. 34.



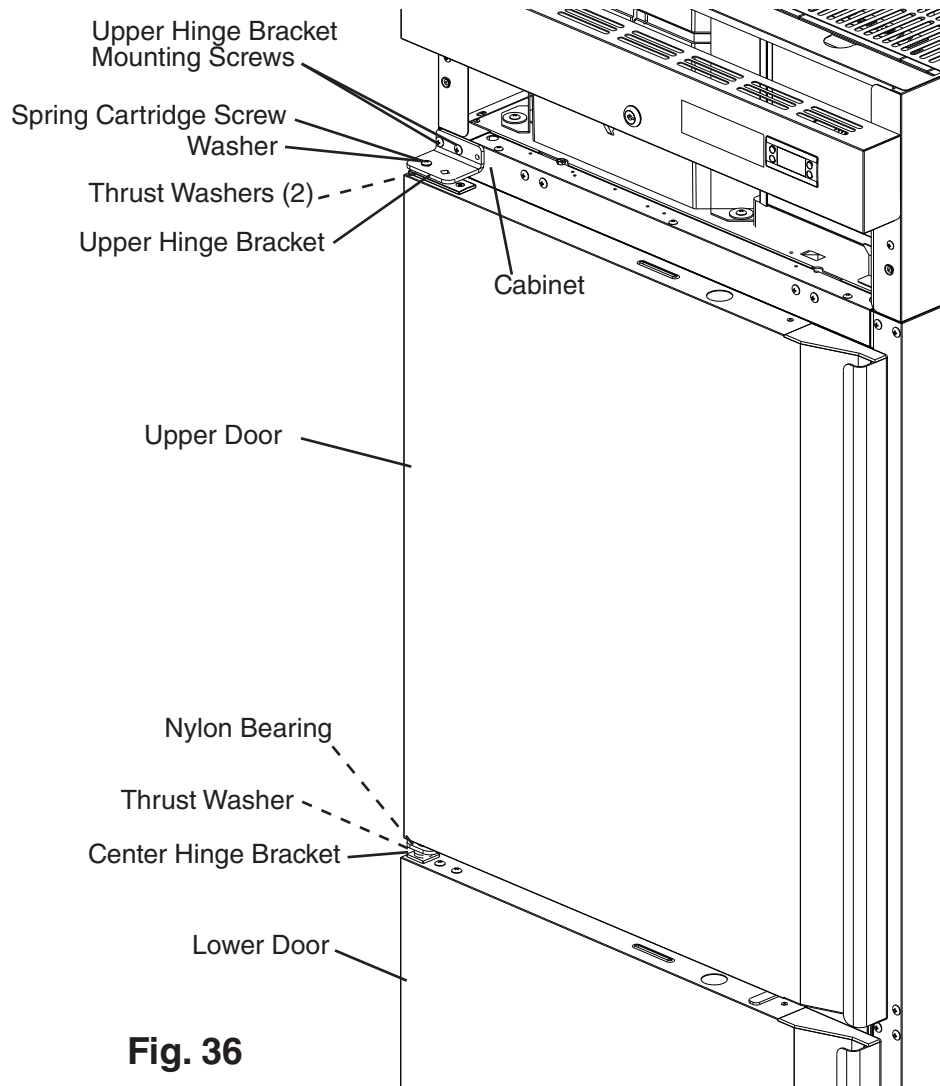
**Fig. 34**

- 14) Secure the door to the lower hinge bracket using the spring cartridge screw and washer.  
Note: Be sure thrust washers (2) are in place between lower hinge bracket and door.  
See Fig 35.
- 15) Verify swing.



**Fig. 35**

- 16) Make sure the center hinge bracket upper thrust washer is in place on top of the center hinge bracket upper pin.
- 17) Align the upper hinge bracket to the upper door in the orientation that allows for closed door installation. Make sure the thrust washers are in place between the upper hinge bracket and upper door, then secure the upper hinge bracket to the door using the spring cartridge screw and washer removed earlier. The spring cartridge shaft should slide into the upper hinge bracket and be flush with the top of the doors upper hinge bracket.
- 18) With the door in the closed position, place the upper doors nylon bearing onto the center hinge bracket upper pin, then secure the upper hinge bracket to the cabinet with the upper door in the closed position. See Fig. 36.
- 19) Verify swing. Move the control panel hole plugs to the other side, then replace and secure the control panel and front panel in their correct positions. Verify light switch and lock function and adjust as necessary.



**Fig. 36**

### 3. Full Glass Door Reversal

#### Special Tools and Item Required:

Wrench A: 1 - 11/16" (17 mm) Thin Open End Tappet Wrench

Wrench B: 1 - 5/16" (8 mm) Thin Open End Tappet Wrench

Loctite Thread Locker Blue 242 or 243

Note: Hoshizaki wrenches and Loctite Thread Locker Blue are available through your local distributor.

Wrench A: [3A8298-01](#),

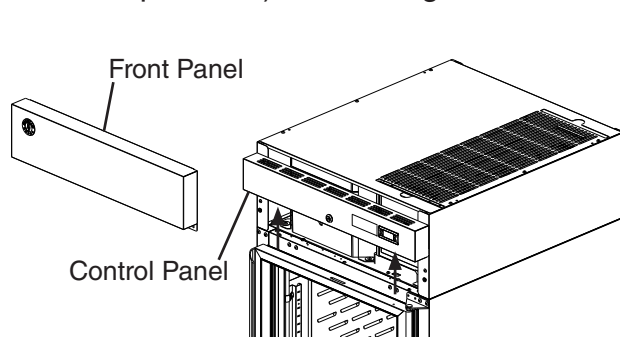
Wrench B: [3A8299-01](#), and

Loctite Thread Locker Blue 243: 8504-0304 (10 ml bottle).

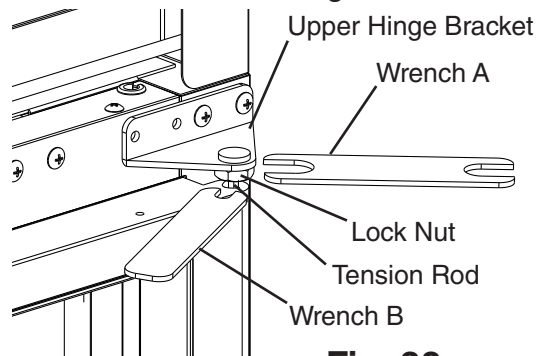
Hinge brackets are universal and can be used in both left and right-hinged applications.

Example shows change from right hinged to left hinged.

- 1) Lock the casters.
- 2) Remove the front panel, then being careful not to pull the wires on the control module and door switch(es), remove the control panel. Secure the control panel so that it does not interfere with the hinge bracket and will not fall. See Fig. 37.
- 3) At the upper hinge bracket, place wrench B on the tension rod and hold (prepare for tension pressure), then using wrench A, loosen the lock nut. See Fig. 38.

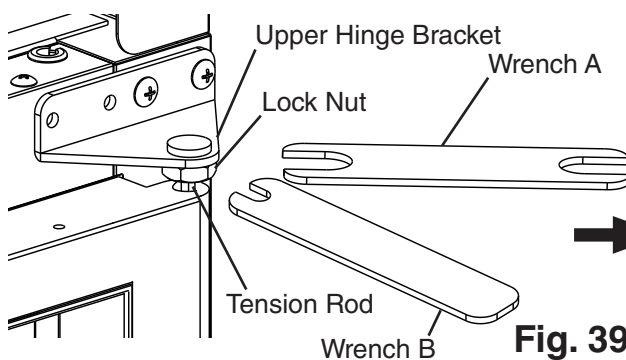


**Fig. 37**

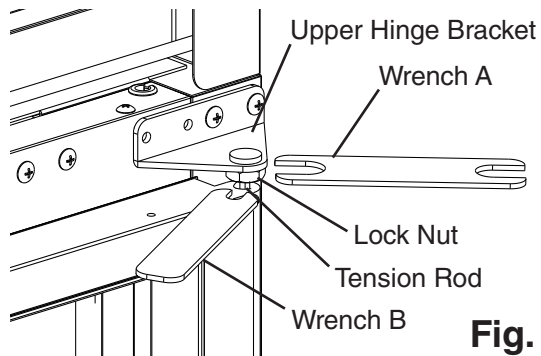


**Fig. 38**

- 4) Turn wrench B counter-clockwise to relieve tension on the tension rod. Without releasing the pressure on wrench B and the tension rod, use wrench A to tighten the lock nut. See Fig. 39.
- 5) Grip wrench B in a new position on the tension rod and hold (prepare for tension pressure), then using wrench A, loosen the lock nut again. See Fig. 40.
- 6) Once loose, turn wrench B counter-clockwise to relieve tension on the tension rod. Repeat until all tension is released from the tension rod.

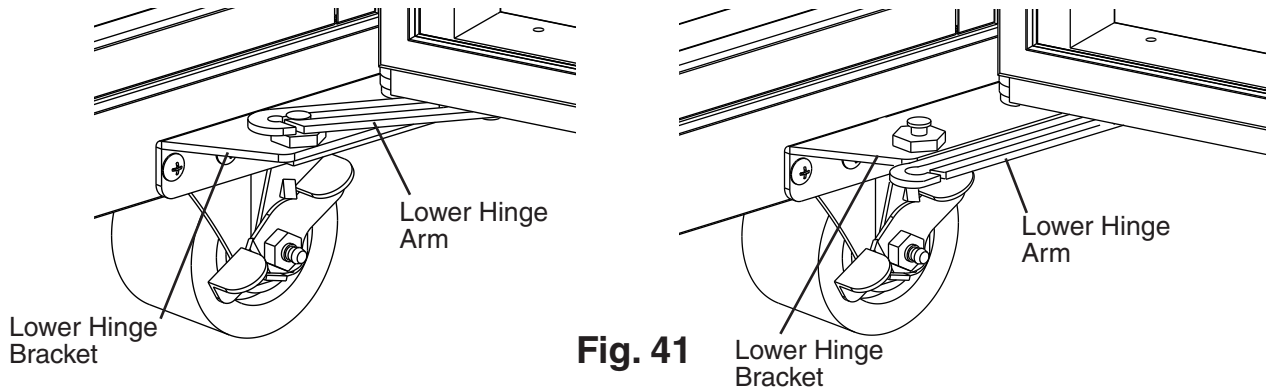


**Fig. 39**



**Fig. 40**

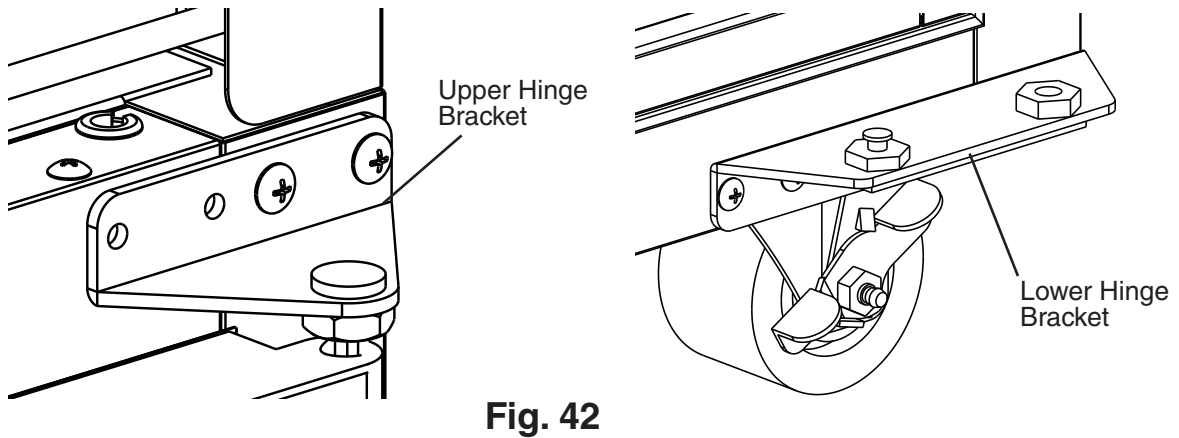
7) Open the door. Using a flat head screwdriver, unhinge the lower hinge arm from the lower hinge bracket. See Fig. 41.



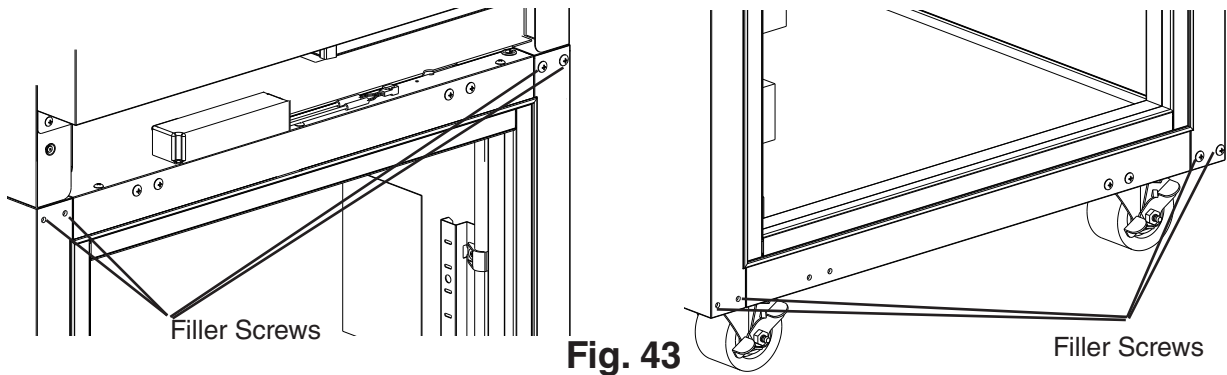
8) Close the door, then remove the screws securing the upper hinge bracket. See Fig. 42.

9) Lift the door off the lower hinge bracket and set aside.

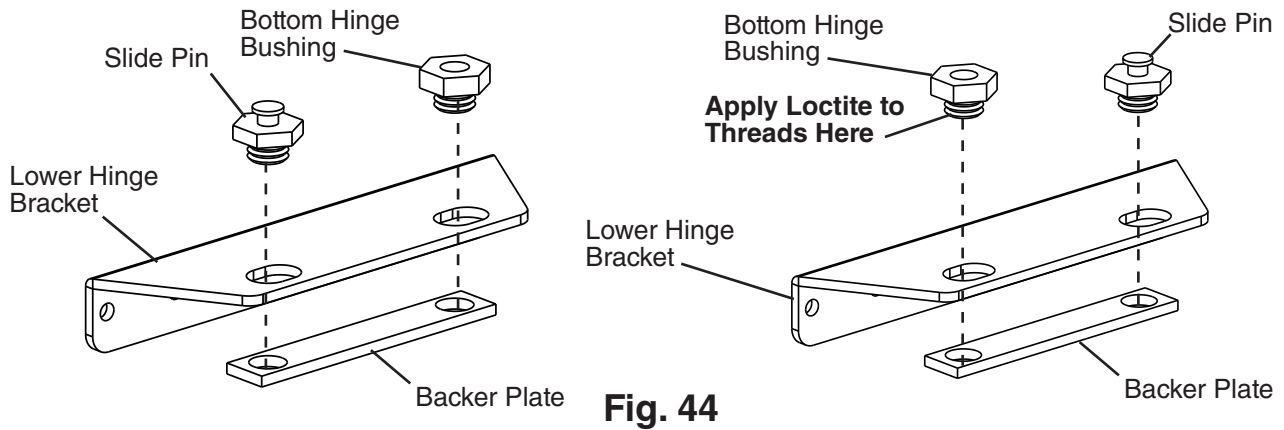
10) Remove the lower hinge bracket from the cabinet.



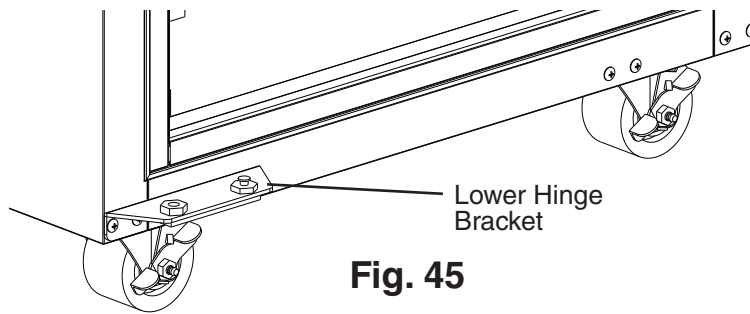
11) Move the upper and lower filler screws to the opposite side of the cabinet. See Fig. 43.  
**NOTICE! Be sure to reuse the bracket screws for mounting the bracket as the bracket screws are 5x12 and filler screws are 5x10.**



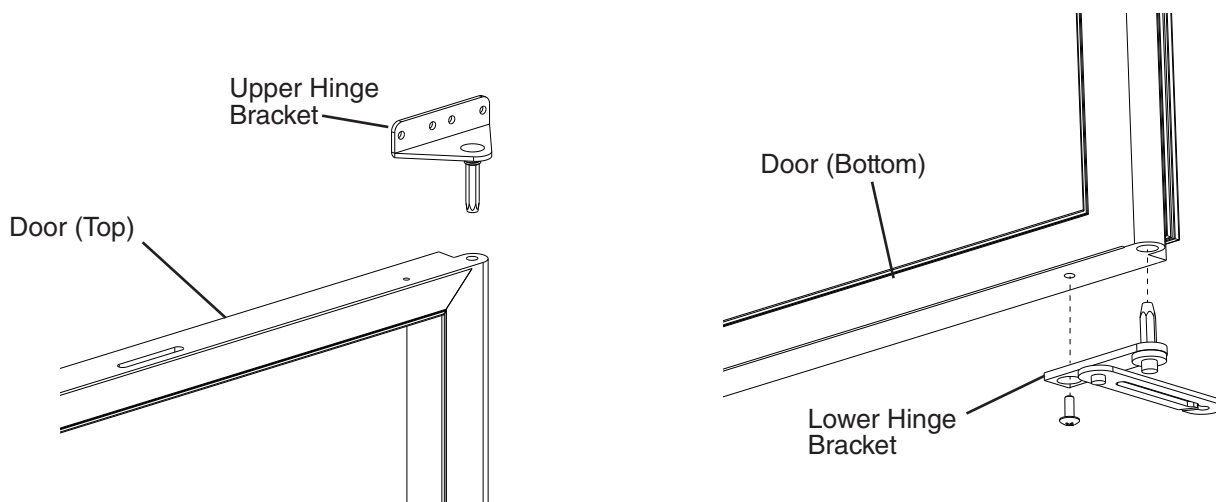
- 12) Remove the hardware from the lower hinge bracket. Apply Loctite Thread Locker Blue 242 or 243 to the bottom hinge bushing threads then place it and the slide pin in place on the lower hinge bracket. See Fig. 44. Note: Make sure the fittings are properly aligned, then start the connection by hand to ensure that it is not cross threaded. Just snug the fittings, do not tighten the fittings at this time.



- 13) Place and secure the new lower hinge bracket in its correct position on the cabinet. See Fig. 45.

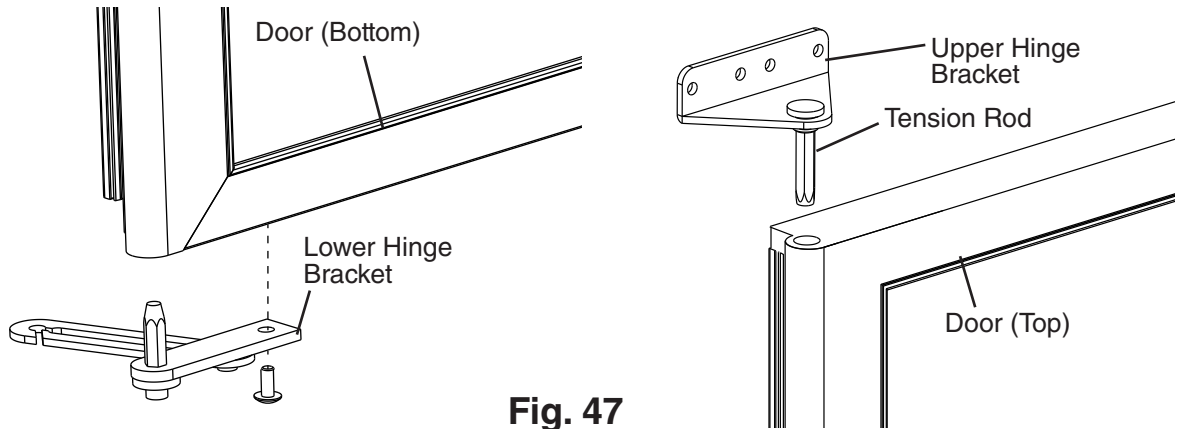


- 14) Remove the upper and lower hinge brackets from the door. See Fig. 46.



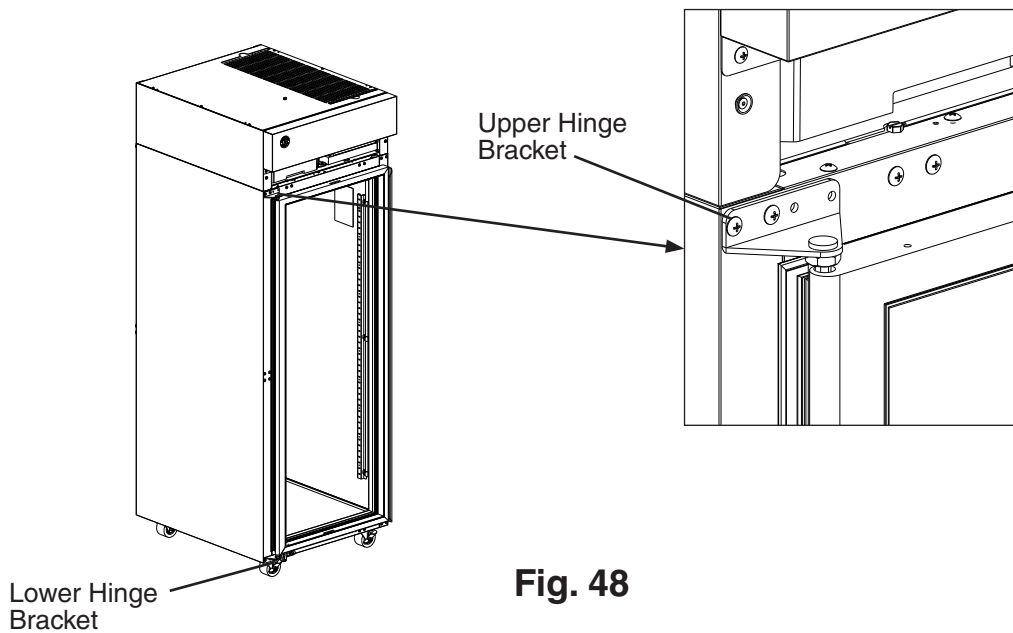
15) Rotate the door 180 degrees and place the lower hinge in its new position and secure. See Fig. 47.

16) Place the upper hinge in its new position on the door.



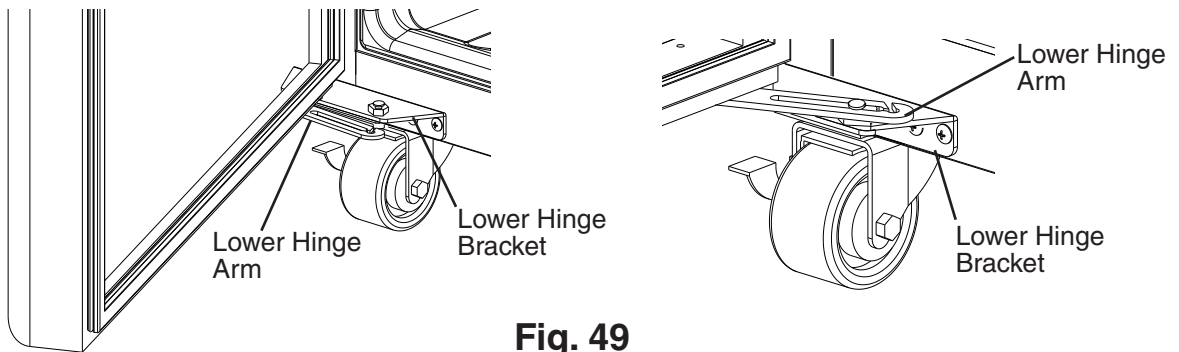
**Fig. 47**

17) Place the door on the lower hinge bracket in the closed position, then secure the upper hinge bracket to the cabinet. See Fig. 48.



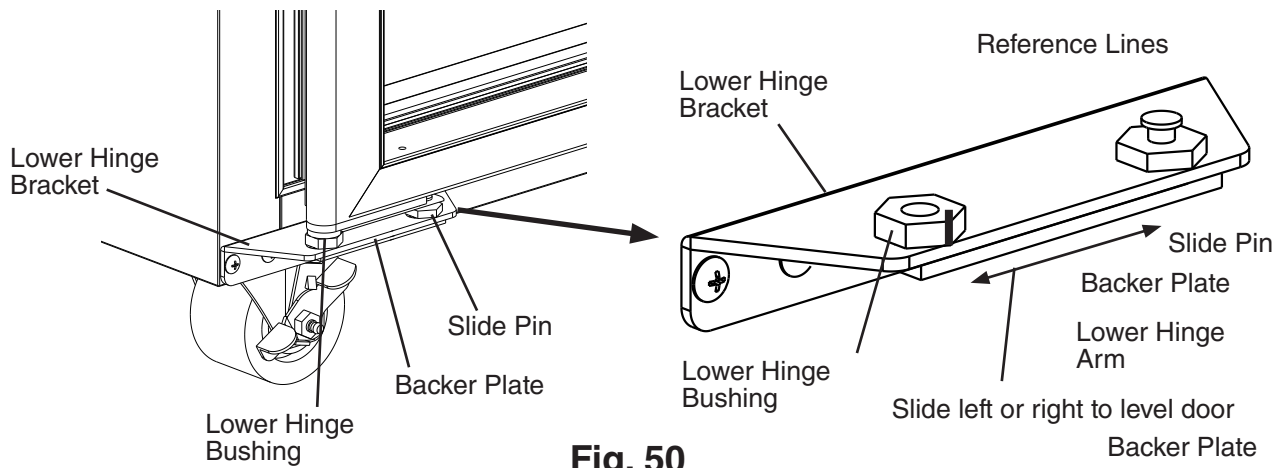
**Fig. 48**

18) Open the door and connect the lower hinge arm to the lower hinge bracket. See Fig. 49.



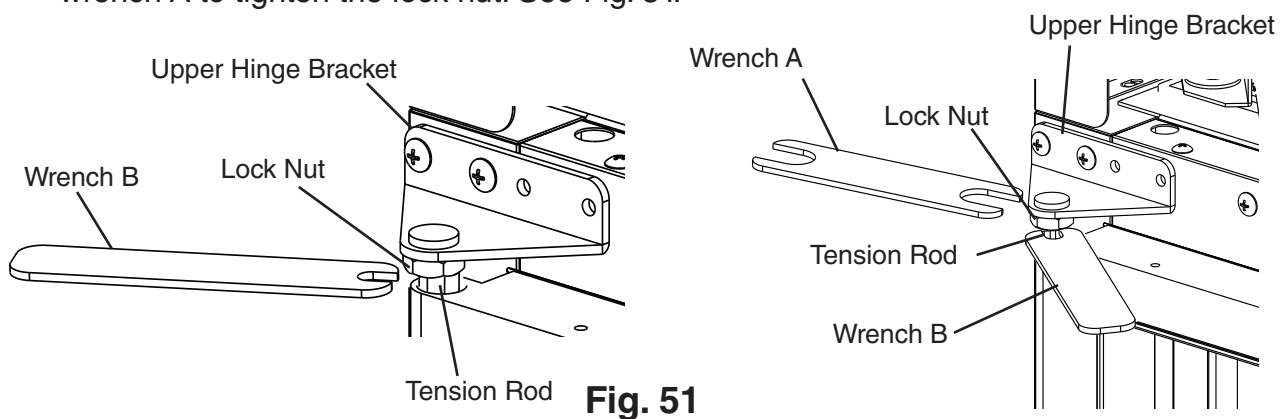
**Fig. 49**

- 19) Close the door. Make sure the upper hinge bracket lock nut is loose.
- 20) Level the door by sliding the backer plate to the left or to the right, then tighten the slide pin and bottom hinge bushing with a wrench until it is tight. See Fig. 50. Next, mark a reference line on the bracket and bushing then tighten the fitting an additional 1/8 turn.



**Fig. 50**

- 21) Place wrench B on the tension rod and rotate counter-clockwise to add tension to the tension rod. Without releasing the pressure on wrench B and the tension rod, use wrench A to tighten the lock nut. See Fig. 51.



**Fig. 51**

- 22) Grip wrench B in a new position on the tension rod and hold (prepare for tension pressure), then using wrench A, loosen the lock nut.
- 23) Once loose, turn wrench B counter-clockwise to add tension on the tension rod. Without releasing the pressure on wrench B and the tension rod, use wrench A to tighten the lock nut.
- 24) Verify swing. Open the door and test the opening and closing tension. Adjust as needed until the door opens and closes correctly.
- 25) Move the control panel hole plugs to the other side, then replace and secure the control panel and front panel in their correct positions. Verify light switch and lock function and adjust as necessary.

#### 4. Half Glass Door Reversal

##### Special Tools Required:

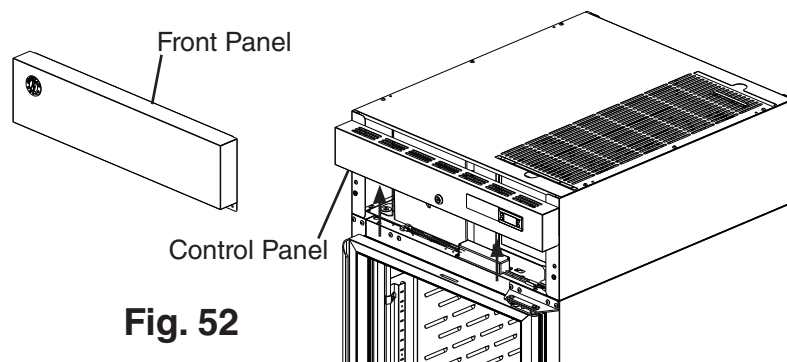
Wrench A: 1 - 11/16" (17 mm) Thin Open End Tappet Wrench

Wrench B: 1 - 5/16" (8 mm) Thin Open End Tappet Wrench

Note: Hinge brackets are universal and can be used in both left and right-hinged applications.

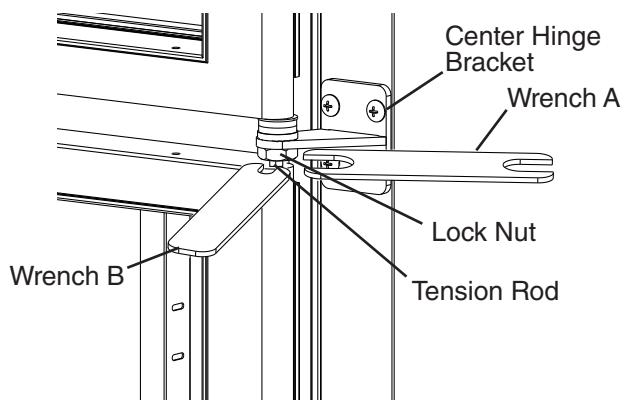
Example shows change from right hinged to left hinged.

- 1) Lock the casters.
- 2) Remove the front panel, then being careful not to pull the wires on the control module and door switch(es), remove the control panel. Secure the control panel so that it does not interfere with the hinge brackets and will not fall. See Fig. 52.

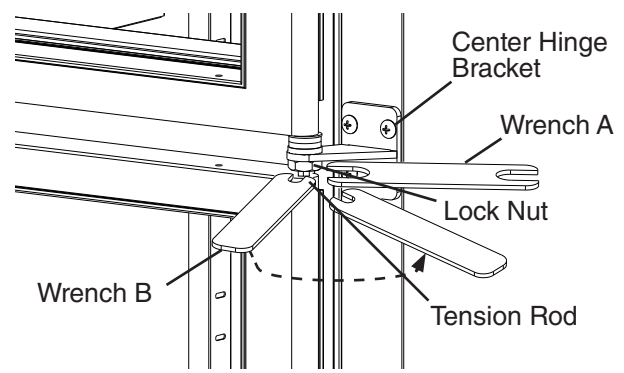


**Fig. 52**

- 3) At the center hinge, place wrench B on the tension rod and hold (prepare for tension pressure), then using wrench A, loosen the lock nut. See Fig. 53.
- 4) Turn wrench B counter-clockwise to relieve tension on the tension rod. Without releasing the pressure on wrench B and the tension rod, use wrench A to tighten the lock nut. See Fig. 54
- 5) Grip wrench B in a new position on the tension rod and hold (prepare for tension pressure), then using wrench A, loosen the lock nut again.
- 6) Once loose, turn wrench B counter clockwise to relieve tension on the tension rod. Repeat until all tension is released from the tension rod.



**Fig. 53**



**Fig. 54**

- 7) Open the upper door. Using a flat head screwdriver, unhinge the upper hinge arm from the upper hinge bracket. See Fig. 55.

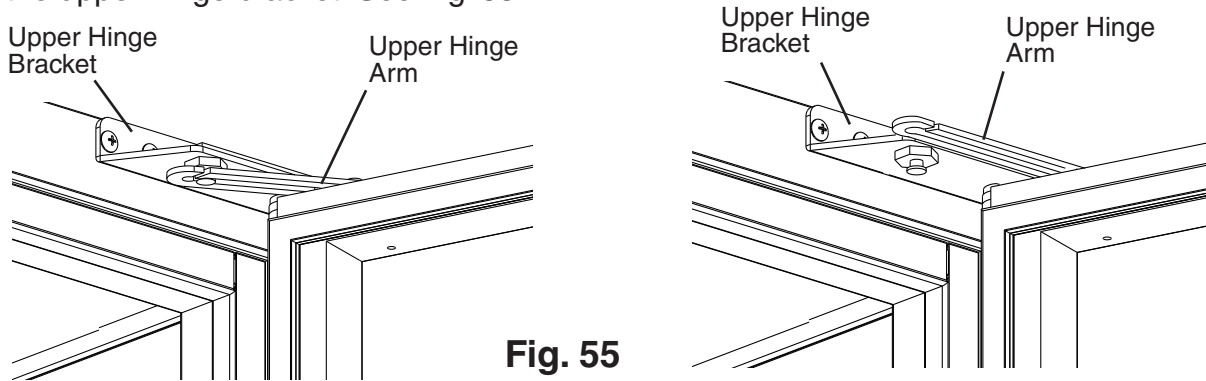


Fig. 55

- 8) Close the upper door, while maintaining a hold on the door, remove the upper hinge bracket, then lift the door off the center hinge bracket upper pin and set aside. See Fig. 56. Retain the upper door thrust washer and the center hinge bracket thrust washers and washer for opposite side hinge bracket installation. **NOTICE! Thrust washers must be in place to prevent wear and damage to the hinge brackets.**

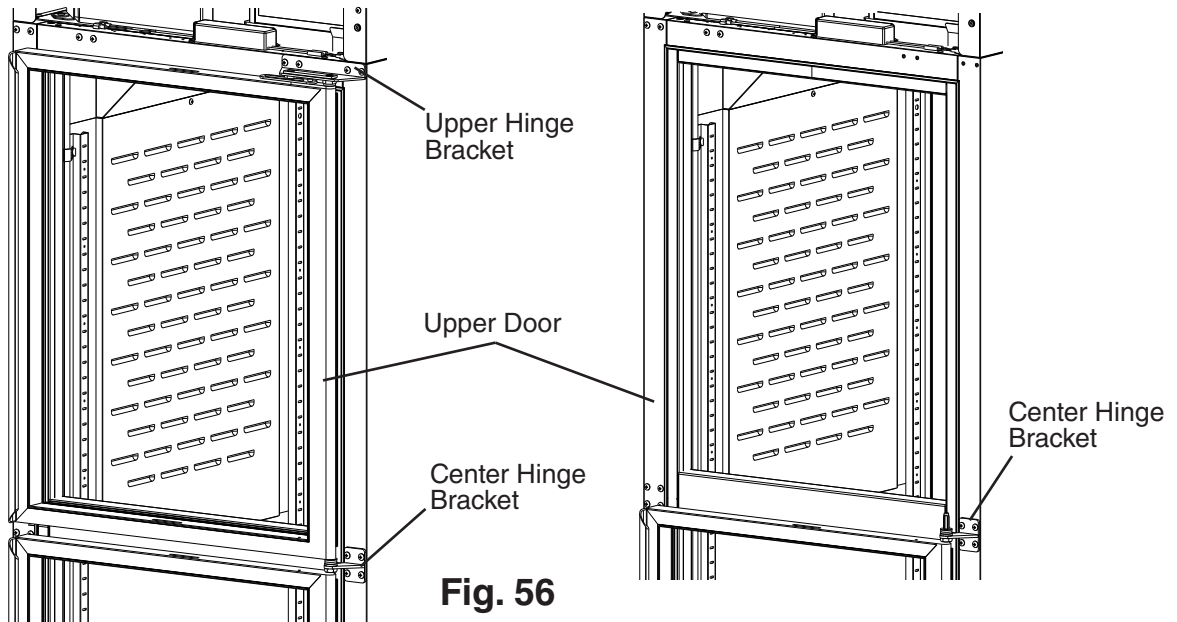


Fig. 56

- 9) Open the lower door. Using a screwdriver, unhinge the lower hinge arm from the lower hinge bracket. See Fig. 57

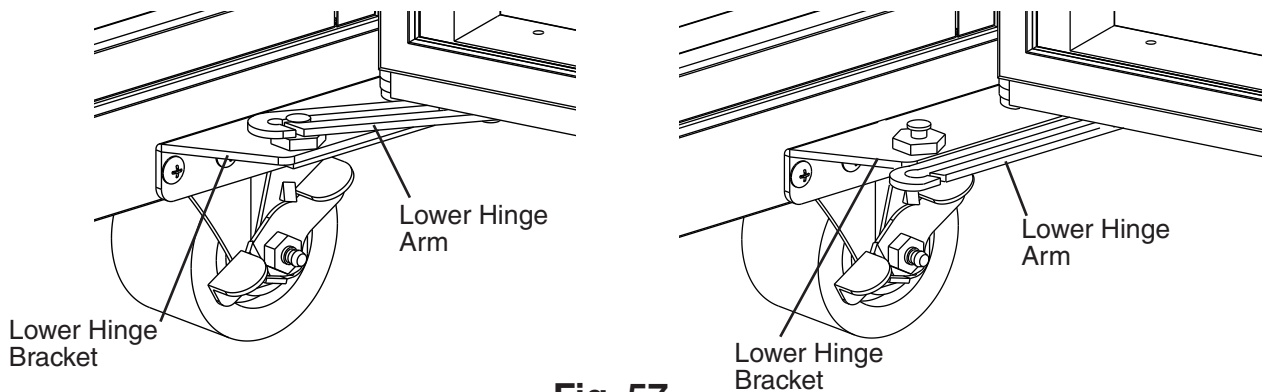
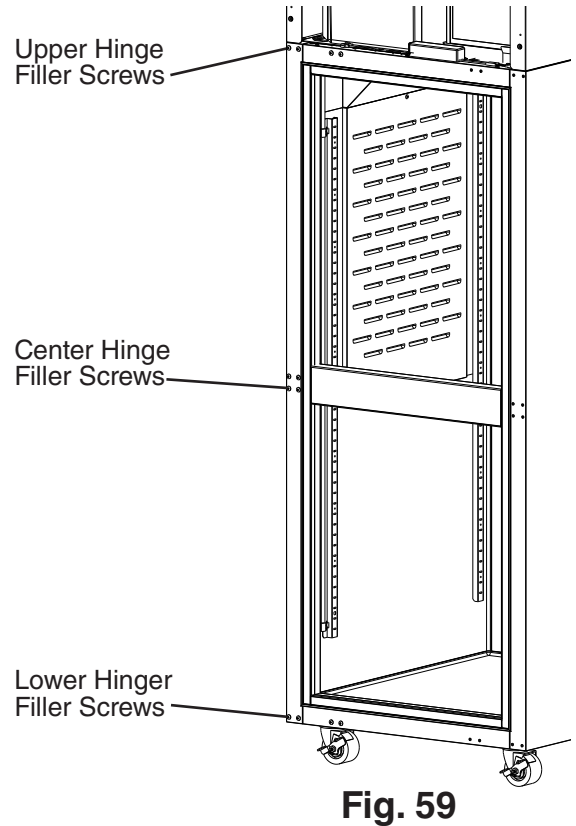
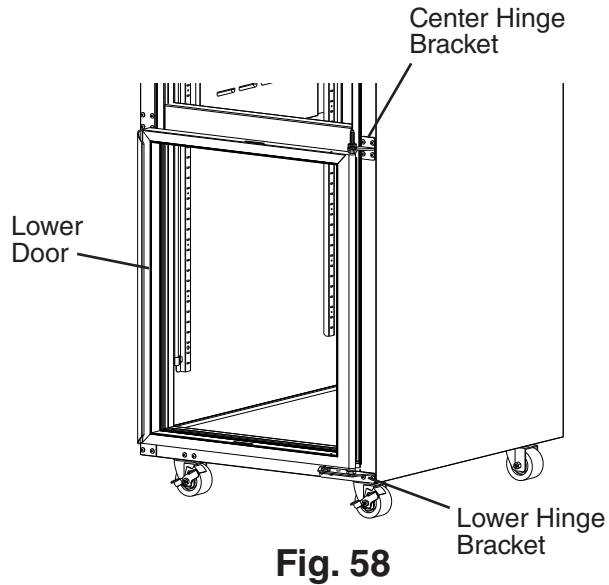
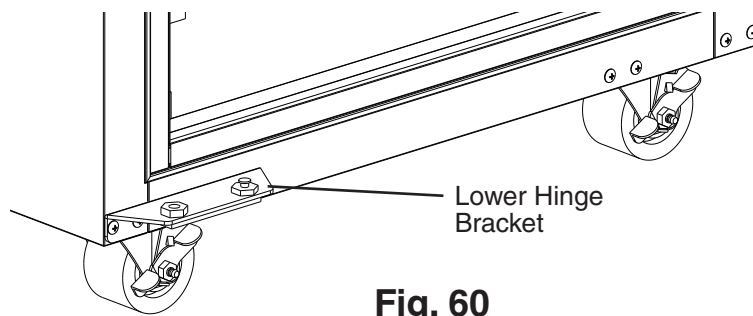


Fig. 57

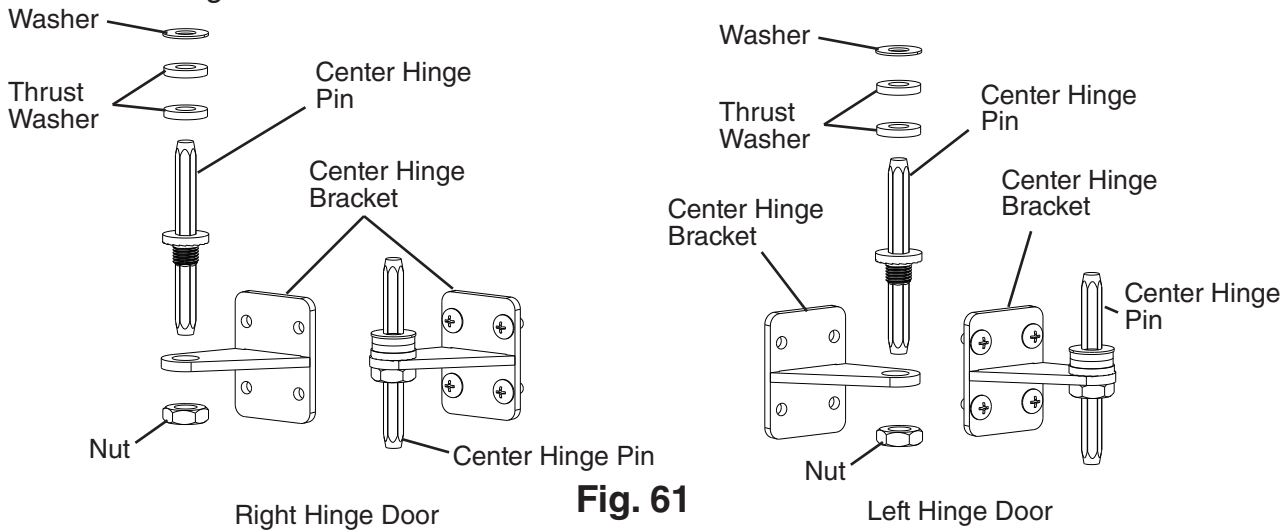
- 10) Close the lower door. While supporting the lower door, remove the screws supporting the center hinge bracket, then lift the lower door (with center hinge bracket) from the lower hinge bracket and set aside. See Fig. 58.
- 11) Remove the lower hinge bracket, then move the filler screws for the upper, center, and lower hinge brackets to the opposite side of the cabinet. See Fig. 59.



- 12) Rotate the upper hinge bracket 180 degrees, then place and secure it in the new lower hinge bracket position. See Fig. 60. **NOTICE! Be sure to reuse the bracket screws for mounting the bracket as the bracket screws are 5x12 and filler screws are 5x10.**

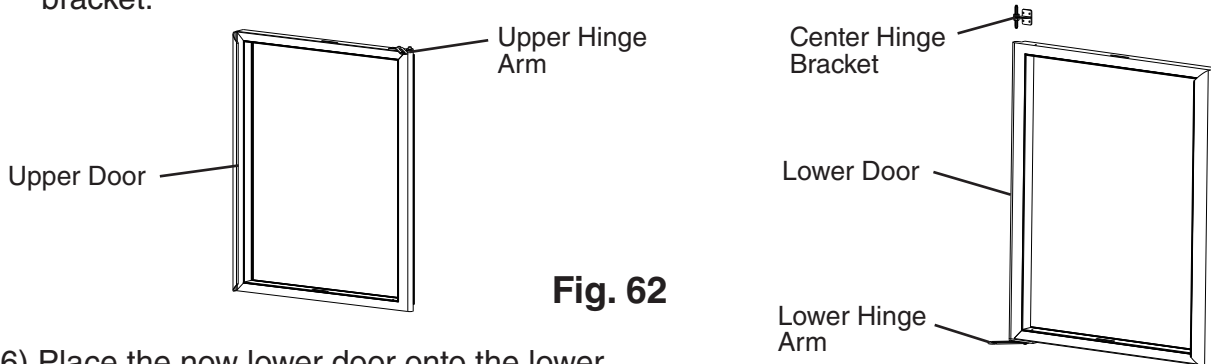


- 13) Remove the lock nut and tension rod from the center hinge bracket. See Fig. 61 Rotate the center hinge bracket 180 degrees, then replace the tension rod and lock nut on the center hinge bracket.



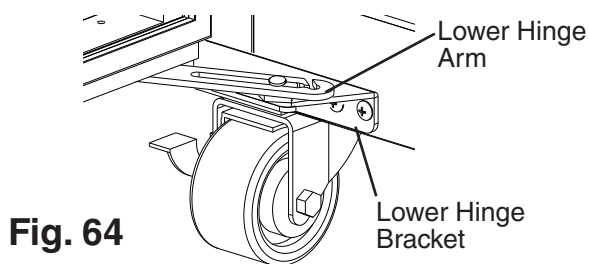
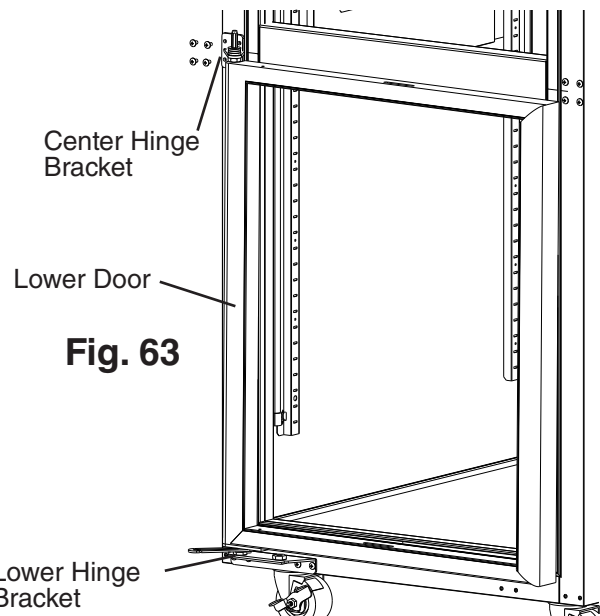
- 14) Rotate the upper door (making it the lower door) 180 degrees and place the center hinge bracket lower pin into the top of the now lower door. See Fig. 62

- 15) Confirm the thrust washer is in place between the lower door and the lower hinge bracket.



- 16) Place the now lower door onto the lower hinge bracket in the closed position. See Fig. 63. While supporting the lower door, secure the center hinge bracket to the cabinet.

- 17) Open the door and connect the lower hinge arm to the slide pin, then close the door. See Fig. 64. **NOTICE! Thrust washers must be in place to prevent wear and damage to the hinge brackets.**



18) Rotate the lower door (making it the upper door) 180 degrees. Rotate the lower hinge bracket 180 degrees. Confirm the thrust washer is in place on the door, then place the new upper hinge bracket onto the upper door pin. See Fig. 65.

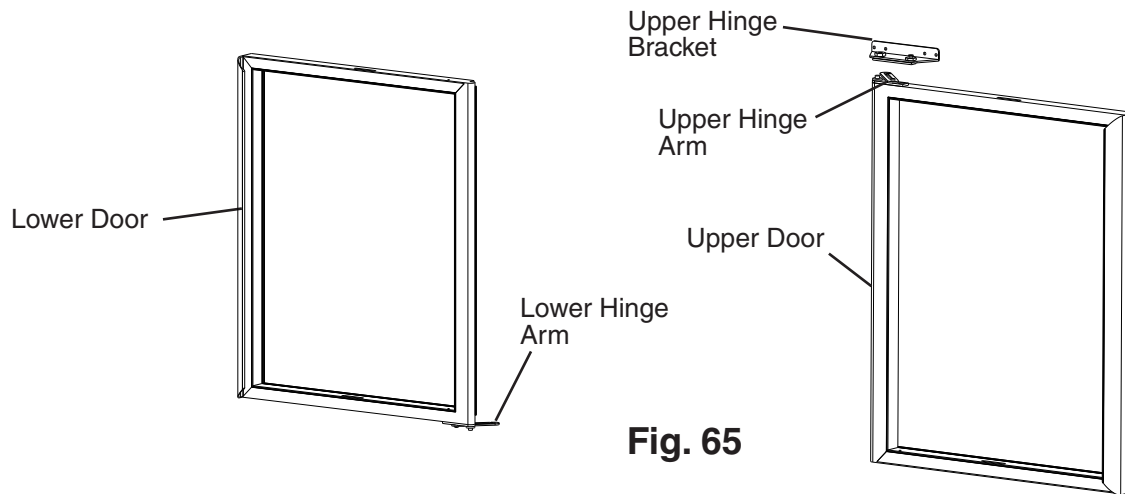


Fig. 65

19) While supporting the upper door and upper hinge bracket, place the upper door onto the upper center hinge pin on the center hinge bracket in the closed position, then secure the upper hinge bracket to the cabinet. See Fig. 66. **NOTICE! Be sure to reuse the bracket screws for mounting the bracket as the bracket screws are 5x12 and filler screws are 5x10.**

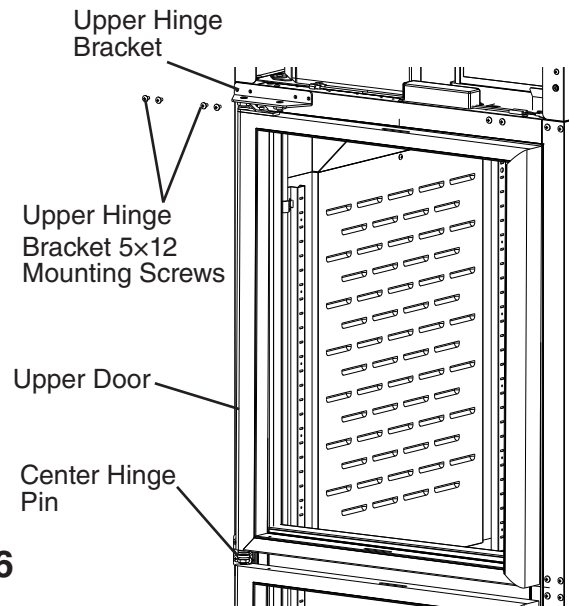


Fig. 66

20) Open the upper door and connect the upper hinge arm to the slide pin on the upper hinge bracket, then close the door. See Fig. 67.

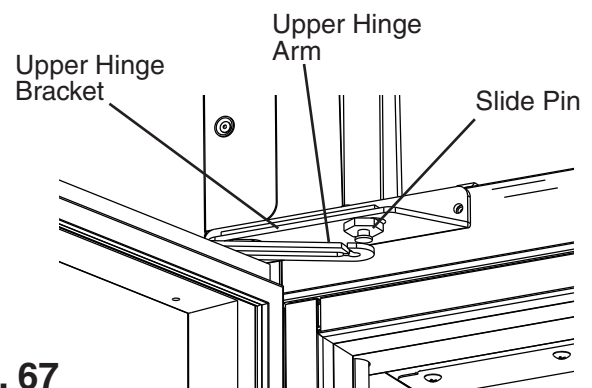
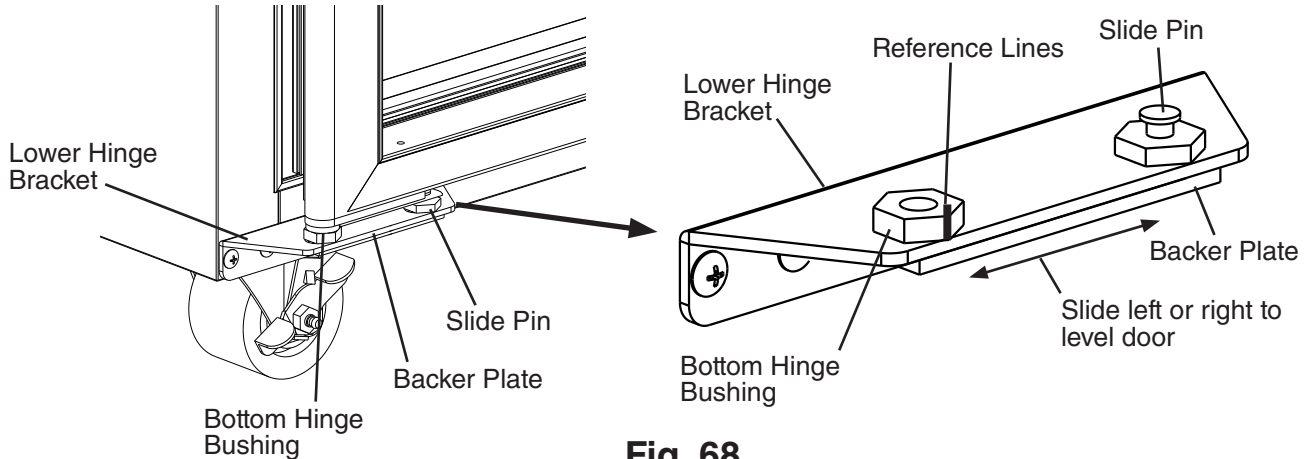


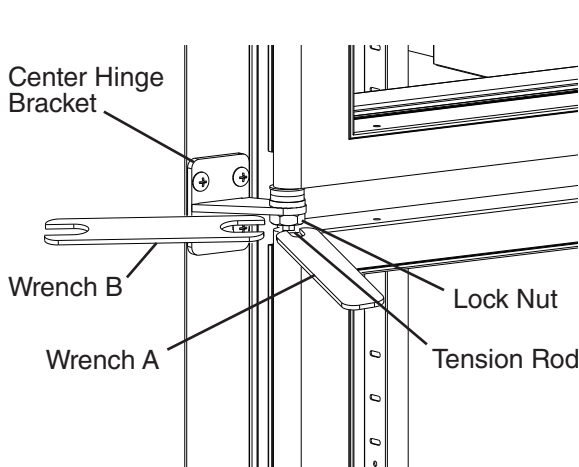
Fig. 67

- 21) Make sure the center hinge bracket lock nut is loose.
- 22) Level the doors. If the doors are out of level, loosen the backer plate of the appropriate hinge bracket, slide the backer plate to the left or to the right, then tighten the slide pin and bottom hinge bushing with a wrench until it is tight. See Fig. 68. Next, mark a reference line on the bracket and fitting then tighten the fitting an additional 1/8 turn. Do this for both the upper and lower hinge.

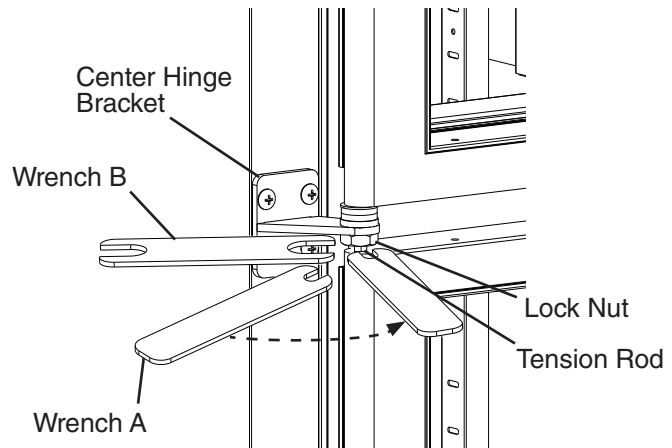


**Fig. 68**

- 23) Place wrench B on the tension rod and rotate counter-clockwise to add tension to the tension rod. Without releasing the pressure on wrench B and the tension rod, use wrench A to tighten the lock nut. See Fig. 69.
- 24) Grip wrench B in a new position on the tension rod and hold (prepare for tension pressure), then using wrench A, loosen the lock nut.
- 25) Once loose, turn wrench B counter-clockwise to add tension on the tension rod. Without releasing the pressure on wrench B and the tension rod, use wrench A to tighten the lock nut. See Fig. 70.



**Fig. 69**





**Fig. 70**

- 26) Verify swing. Open the doors and test the opening and closing tension of each door. Adjust as needed until the doors open and close correctly.
- 27) Move the control panel hole plugs to the other side, then replace and secure the control panel and front panel in their correct positions. Verify light switch and lock function and adjust as necessary.

## G. Electrical Connection

### **WARNING**

- Electrical connection must meet national, state, and local electrical code requirements. Failure to meet these code requirements could result in death, electric shock, serious injury, fire, or severe damage to equipment.
  - This appliance requires an independent power supply of proper capacity. See the nameplate for electrical specifications. Failure to use an independent power supply of proper capacity can result in a tripped breaker, blown fuse, damage to existing wiring, or component failure. This could lead to heat generation or fire.
  - **115VAC Models: THIS APPLIANCE MUST BE GROUNDED:** This appliance is equipped with a NEMA 5-15 three-prong grounding plug  to reduce the risk of potential shock hazards. It must be plugged into a properly grounded, independent 3-prong wall outlet. If the outlet is a 2-prong outlet, it is your personal responsibility to have a qualified electrician replace it with a properly grounded, independent 3-prong wall outlet. Do not remove the ground prong from the plug and do not use an adapter plug. Failure to follow these instructions may result in death, electric shock, or fire.
  - **208/230VAC Models: THIS APPLIANCE MUST BE GROUNDED:** This appliance is equipped with a NEMA L14-20 four-prong locking, grounding plug  to reduce the risk of potential shock hazards. It must be plugged into a properly grounded, independent 4-prong wall outlet. If the outlet is a 3-prong outlet or a 4-prong non-locking outlet, it is your personal responsibility to have a qualified electrician replace it with a properly grounded, independent 4-prong locking wall outlet. Do not remove the ground prong from the plug and do not use an adapter plug. After plugging in, twist the plug clockwise to lock it into place. Failure to follow these instructions may result in death, electric shock, or fire.
  - To reduce the risk of electric shock, do not touch the plug with damp hands.
  - Press and hold the standby button to turn "OFF" before unplugging the appliance to reduce the risk of electric shock.
  - Do not use an extension cord.
  - Do not use an appliance with a damaged power cord. The power cord should not be altered, jerked, bundled, weighed down, pinched, or tangled. Such actions could result in electric shock or fire. To unplug the appliance, be sure to pull the plug, not the cord, and do not jerk the cord.
  - The GREEN ground wire in the factory-installed power cord is connected to the appliance. If it becomes necessary to remove or replace the power cord, be sure to connect the power cord's ground wire.
- Usually an electrical permit and services of a licensed electrician are required.
  - The maximum allowable voltage variation is  $\pm 10$  percent of the nameplate rating.

## H. Final Checklist

- 1) Is the appliance level?
- 2) Have the front casters been locked?
- 3) Is the appliance in a site where the ambient temperature is as specified below all year around?
  - Refrigerators and Solid Door Freezers 45°F to 100°F (7°C to 38°C)
  - Glass Door Freezers 45°F to 80°F (7°C to 27°C)

- 4) Have the minimum clearance requirements specified below been met?

Models	Side	Top	Rear
Reach-In Refrigerators and Freezers Except 2-Section Freezers	0" (0 cm)	0" (0 cm)	3" (8 cm)
2-Section Freezers	0" (0 cm)	10" (25 cm)	3" (8 cm)

- 5) Have the shipping carton, tape, and packing material been removed from the appliance? Has the protective plastic film been removed from the exterior panels on all models and from the interior door panels on solid door models?
- 6) Have the appliance and accessories been checked for shipping damage?
- 7) Has the power supply voltage been checked or tested against the nameplate rating? Is the power supply a properly grounded, independent wall outlet? Does the electrical connection meet all national, state, and local code and regulation requirements.
- 8) Have the refrigerant lines been checked to make sure they do not rub or touch other lines or surfaces? Has the condenser fan blade been checked to make sure it turns freely? Is the compressor securely attached?
- 9) Have the shelves been properly installed?
- 10) Has the end user been given the instruction manual, and instructed on how to operate the appliance and the importance of the recommended periodic maintenance?
- 11) Has the end user been given the name and telephone number of an authorized service agent?
- 12) Has the warranty card been filled out and forwarded to the factory for warranty registration?

## II. Operating Instructions

### A. Important Notes About Usage

#### **DANGER**

##### **Risk of Fire or Explosion**

##### **Flammable Refrigerant Used**

- Do not use mechanical devices to defrost.
- Do not puncture refrigerant tubing. Risk of fire or explosion due to puncture of refrigerant tubing; follow handling instructions carefully.
- Do not place any potential ignition sources in or near the appliance.

##### **Risque De Feu Ou D'Explosion**

##### **Le Frigorigène Est Inflammable**

- Ne pas utiliser d'appareils mécaniques pour dégivrer le réfrigérateur.
- Ne pas perforer la tubulure contenant le frigorigène. Risque de feu ou d'explosion si la tubulure contenant le frigorigène est perforée; suivre les instructions de manutention avec soin.
- Ne placez aucune source d'inflammation potentielle dans ou près de l'appareil.

#### **WARNING**

- Only qualified service technicians should install and service the appliance.
- Wear appropriate personal protective equipment (PPE) when servicing the appliance.
- Failure to install, operate, and maintain the appliance in accordance with this manual may adversely affect safety, performance, component life, and warranty coverage.
- To reduce the risk of electric shock, do not touch the plug with damp hands.
- Do not splash, pour, or spray water directly onto or into the appliance. This might cause short circuit, electric shock, corrosion, or failure.

#### **WARNING, continued**

- The appliance is not intended for use by persons (including children) with reduced physical, sensory, or mental capabilities, or lack of experience and knowledge, unless they have been given supervision or instruction concerning use of the appliance by a person responsible for their safety.
- Children should be properly supervised around the appliance.
- Do not climb, stand, or hang on the appliance or doors or allow children or animals to do so. Do not climb into the appliance or allow children or animals to do so. Death or serious injury could occur or the appliance could be damaged.
- Be careful not to pinch fingers when opening and closing the doors. Be careful when opening and closing the doors when children are in the area.
- Open and close the doors with care. Opening the doors too quickly or forcefully may cause injury or damage to the appliance or surrounding equipment.
- Do not use combustible spray or place volatile or flammable substances in or near the appliance. They might catch fire.
- Keep the area around the appliance clean. Dirt, dust, or insects in the appliance could cause harm to individuals or damage to the equipment.
- Do not throw anything onto the shelves or load any single shelf with more than 120 lb. (54.5 kg) of product. They might fall off and cause injury.
- Do not place more than 20 lb. (9 kg) on the top panel. Items must be stable and secure to prevent items from falling off of the appliance.
- Care should be used when placing items on top of the appliance. Do not store liquid containers or items that could fall through the louvers on top of the appliance. This could cause electric shock or fire.

**⚠ WARNING, continued**

- The appliance is designed only for temporary storage of food. Employ sanitary methods. Use for any other purposes (for example, storage of chemicals or medical supplies such as vaccine and serum) could cause deterioration of stored items.
- Do not block air inlets or outlets, otherwise cooling performance may be reduced.
- Do not tightly pack the cabinet. Allow some space between items to ensure good air flow. Also allow space between items and interior surfaces.
- Do not put warm or hot foods in the cabinet. Let them cool first, or they will raise the cabinet temperature and could deteriorate other foods in the cabinet or overload the appliance.
- Food storage and handling must comply with applicable codes and regulations.
- All foods should be wrapped in plastic film or stored in sealed containers. Otherwise foods may dry up, pass their smells onto other foods, cause frost to develop, result in poor appliance performance, or increase the likelihood of cross-contamination. Certain dressings and food ingredients, if not stored in sealed containers, may accelerate corrosion of the evaporator, resulting in failure.
- Do not store items near air outlets. Otherwise, items may freeze up and crack or break causing a risk of injury or contamination of other food.
- Do not place any product on the floor of the cabinet. All product must be placed on properly installed shelves.

**NOTICE**

- Protect the floor when moving the appliance to prevent damage to the floor.
- Keep ventilation openings, in the appliance enclosure or in the built-in structure, clear of obstruction. Blockage of airflow could negatively affect performance and damage the appliance.
- Do not allow the appliance to bear any outside weight.
- To prevent deformation or cracks, do not spray insecticide onto the plastic parts or let them come into contact with oil.
- To avoid damage to the gasket, use only the door handle when opening and closing.
- Do not leave the doors open.

## B. Startup

### ⚠ WARNING

- All parts are factory-adjusted. Improper adjustments may adversely affect safety, performance, component life, and warranty coverage.
- To reduce the risk of electric shock, do not touch the plug with damp hands.

### IMPORTANT

At startup, there is a slight delay before the compressor starts.

- 1) Plug the appliance into the electrical outlet. **IMPORTANT! Perimeter heater, mullion heater, and drain tube heater (drain tube heater on freezer models only), energize once appliance is plugged into the electrical outlet and remain energized even while the control module is in "OFF" mode. Appliance must be unplugged from the electrical outlet to de-energize the heaters.**
- 2) If the cabinet temperature is not displayed on the control module, press and hold the standby button on the control module until "ON" appears in the display. See Fig. 71. Factory default is "ON".
- 3) Allow the appliance to cool down prior to loading it with food products.  
Note: If the defrost thermistor is above 50°F (10°C), the evaporator fan motor is de-energized until the defrost thermistor is below 50°F (10°C).

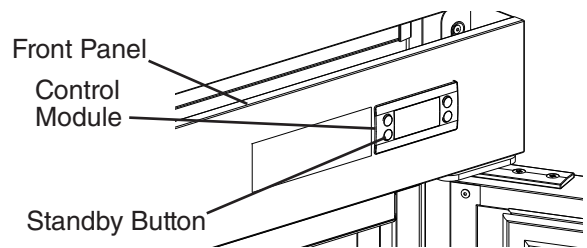


Fig. 71

## C. Controls and Adjustments

### 1. Temperature Display

The cabinet temperature is displayed on the control module. See Fig. 72. The display default is °F, but it can be changed to read °C. To change, see "II.C.3. Changing the Temperature Display Scale (°F or °C)."

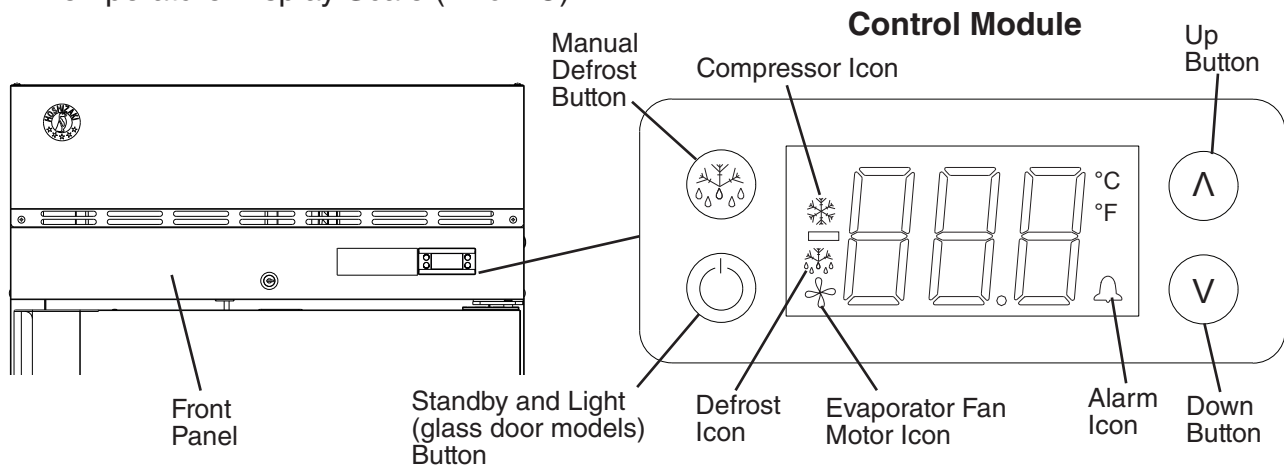


Fig. 72

## 2. Adjusting the Temperature Setpoint

The temperature setpoint is the value for the average cabinet temperature. The temperature differential for the compressor to turn on and off is  $\pm 3^{\circ}\text{F}$  ( $\pm 1.7^{\circ}\text{C}$ ) of the temperature setpoint. For example, for a refrigerator temperature setpoint of  $36^{\circ}\text{F}$  ( $2^{\circ}\text{C}$ ), the compressor comes on at  $39^{\circ}\text{F}$  ( $3.7^{\circ}\text{C}$ ), and the compressor goes off at  $33^{\circ}\text{F}$  ( $0.3^{\circ}\text{C}$ ). If necessary, adjust the temperature setpoint temperature as follows:

- 1) To change the temperature setpoint, press and release the up or down button. The current temperature setpoint appears. Press the up or down button until the desired value is displayed. After a few seconds, the display returns to the current cabinet temperature and the temperature setpoint is saved. **NOTICE! Do not adjust the temperature setpoint more than  $2^{\circ}\text{F}$  ( $1^{\circ}\text{C}$ ) at a time. Allow the temperature to stabilize for a minimum of 8 hours before making further temperature setpoint adjustments.**
  - For refrigerators, the temperature setpoint is adjustable between  $31^{\circ}\text{F}$  and  $52^{\circ}\text{F}$  ( $-0.5^{\circ}\text{C}$  and  $11^{\circ}\text{C}$ ). The factory default is  $38^{\circ}\text{F}$  ( $3^{\circ}\text{C}$ ).
  - For freezers, the temperature setpoint is adjustable between  $-10^{\circ}\text{F}$  and  $+12^{\circ}\text{F}$  ( $-24^{\circ}\text{C}$  and  $-11^{\circ}\text{C}$ ). The factory default is  $-2^{\circ}\text{F}$  ( $-19^{\circ}\text{C}$ ).

## 3. Changing the Temperature Display Scale ( $^{\circ}\text{F}$ or $^{\circ}\text{C}$ )

To change the temperature display scale, press either the up or down button for 5 seconds. The factory default is  $^{\circ}\text{F}$ .

## 4. Light Control for Glass Door Models

Glass door models feature lights that are controlled by the Standby/Light control button located on the control module. See Fig. 73. Press the standby/light button quickly to turn the light on or off.

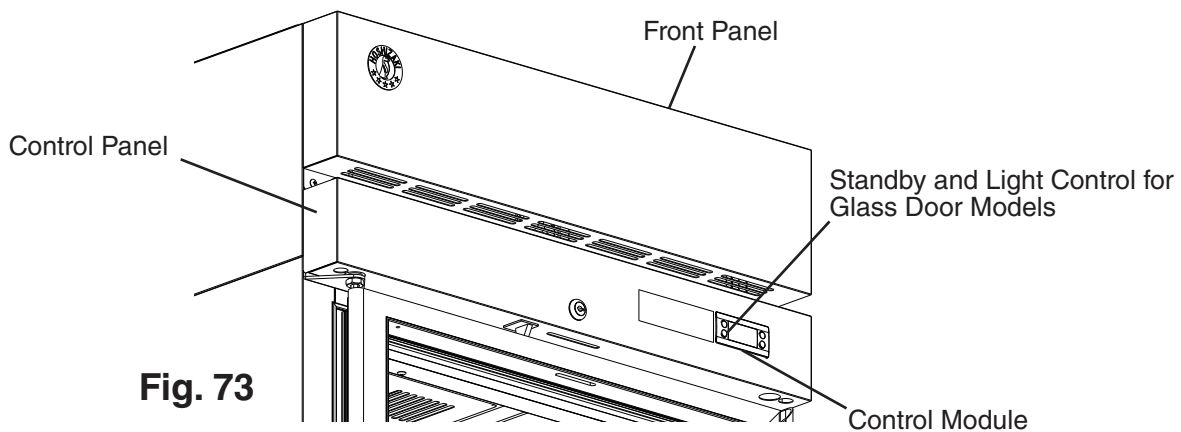




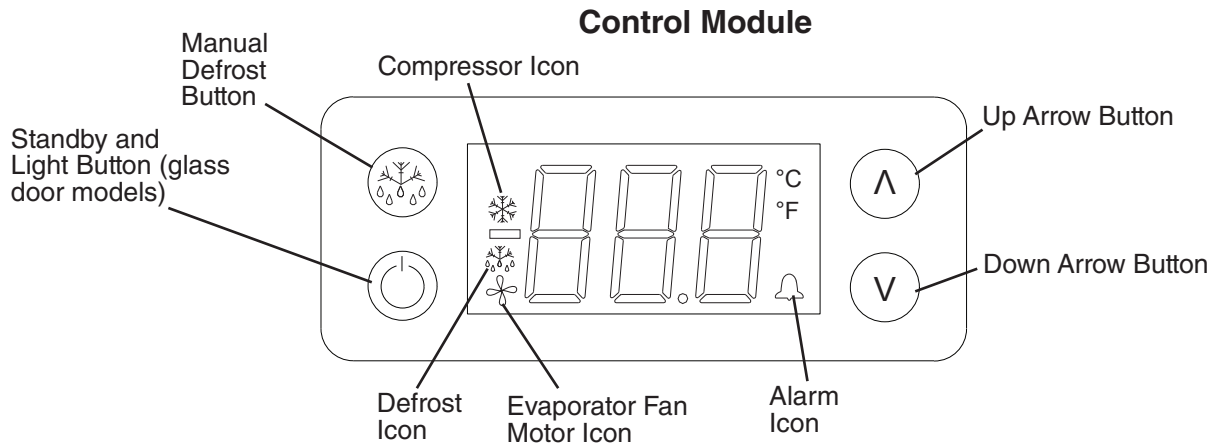


Fig. 73

## D. Control Module Buttons and Icons

Control module icons inform you of energized components and if the appliance is in alarm.

Control Module Icons	
Icon	Meaning
	Compressor Compressor running.
	Defrost Appliance is in defrost cycle. See "II.E. Defrost" for details.
	Evaporator Fan Motor Evaporator fan motor is running. Evaporator fan motor de-energizes when door is open (except DT1A).
	Alarm Appliance is in alarm. See "II.G. Alarm Safeties" for details.



**Fig. 74**

## E. Defrost

### DANGER

#### **Risk of Fire or Explosion Flammable Refrigerant Used**

- Do not use mechanical devices to defrost.
- Do not puncture refrigerant tubing. Risk of fire or explosion due to puncture of refrigerant tubing; follow handling instructions carefully.

#### **Risque De Feu Ou D'Explosion Le Frigorigène Est Inflammable**

- Ne pas utiliser d'appareils mécaniques pour dégivrer le réfrigérateur.
- Ne pas perforer la tubulure contenant le frigorigène. Risque de feu ou d'explosion si la tubulure contenant le frigorigène est perforée; suivre les instructions de manutention avec soin.

### 1. Refrigerators

Refrigerators use a time-initiated, off-cycle defrost. Defrost occurs when either the 2-hr. cumulative compressor run timer terminates or the 2-hr. continuous compressor run timer terminates. When either the 2-hr. cumulative compressor run timer or the 2-hr. continuous compressor run timer terminates, defrost begins. The 5-min. minimum defrost timer and the 1-hr. maximum defrost timer starts. If energized, the compressor de-energizes and the evaporator fan motor continues. Cabinet temperature is not displayed during defrost; "dEF" is displayed in its place along with defrost icon. After the 5-min. minimum defrost timer terminates and the defrost thermistor warms to 44°F (6.6°C), defrost terminates. The defrost icon turns off and the compressor energizes. "dEF" is displayed during defrost and continues for 15 min. after defrost termination. Once the 15-min. "dEF" display timer terminates, cabinet temperature returns to the display. Note: If the defrost thermistor is above 50°F (10°C) the evaporator fan motor de-energizes until the defrost thermistor drops to 49°F (9°C).

### 2. Freezers

Freezers use a time-initiated, heated defrost. Defrost occurs when either the 5-hr. cumulative compressor run timer terminates or the 4-hr continuous compressor run timer terminates. When either the 5 hr. cumulative compressor run timer or the 4-hr continuous run timer terminates, defrost begins. The 5-min. minimum defrost timer and the 1-hr. maximum defrost timer starts. If energized, the compressor and evaporator fan motor de-energizes. Cabinet temperature is not displayed during defrost; "dEF" is displayed in its place along with the defrost icon. After the 5-min. minimum defrost timer terminates and the defrost thermistor warms to 77°F (25°C), defrost terminates (defrost heater de-energizes). A 3-min. compressor delay timer starts. Once the 3-min. compressor delay timer terminates, the compressor energizes and a 4-min. evaporator fan motor delay timer (drip time) starts. Once the 4-min. evaporator fan motor delay timer (drip time) terminates, the evaporator fan motor energizes, the defrost icon turns off, and the 15-min. temperature display delay timer starts. Once the 15-min. temperature display delay timer terminates, cabinet temperature is displayed. Note that the 4-min. evaporator fan motor delay time is a maximum; if the defrost thermistor cools to 15°F (-9.5°C) before the 4-min. evaporator fan motor delay timer terminates, the evaporator fan motor will energize. Note: If the defrost thermistor is above 32°F (0°C) the evaporator fan motor de-energizes until the defrost thermistor drops to 29°F (-0.5°C).

### 3. Manual Defrost

To initiate a manual defrost, press the manual defrost button, defrost begins.

## F. Food Storage

### **WARNING**

- This appliance is designed only for storage of food. Employ sanitary methods. Use for any other purposes (for example, storage of chemicals or medical supplies such as vaccine and serum) could cause deterioration of stored items.
- Do not block the cabinet air inlet or outlet, otherwise cooling performance may be reduced.
- Do not tightly pack the cabinet. Allow some space between items to ensure good air flow. Also allow space between items and interior surfaces.
- Do not place any product on the floor of the cabinet. All product must be placed on properly installed shelves.
- Do not put warm or hot foods in the cabinet. Let them cool first, or they will raise the cabinet temperature and could deteriorate other foods in the cabinet or overload the appliance.
- All foods should be wrapped in plastic film or stored in sealed containers. Otherwise foods may dry up, pass their smells onto other foods, cause frost to develop, result in poor appliance performance, or increase the likelihood of cross-contamination. Certain dressings and food ingredients, if not stored in sealed containers, may accelerate corrosion of the evaporator, resulting in failure.
- Do not store items near the air outlet. They might freeze up and crack or break causing a risk of injury or contamination of other food.

## G. Alarm Safeties

Alarm signals are designed to protect the appliance and food product. These alarms give information or warnings in the event the appliance is operating out of acceptable parameters. Should one of the alarms occur, follow the instructions in the table below to address the alarm. The alarm code and alarm icon flash with audible alarm.

Alarm Signals		
Alarm Code	Problem	Corrective Action/Reset Details
dor	Door Switch Alarm: Door has remained open for more than 2 minutes.  Door Is Open or The Door Switch has failed	If obvious corrections such as closing doors does not correct the alarm, call a qualified service technician.  Beeps for 10 seconds, then silent for 50 seconds. To silence the alarm, press and release the up button.
E01	Cabinet Thermistor Malfunction Alarm  Cabinet thermistor has failed.	Call a qualified service technician.  Beeps for 10 seconds, then silent for 50 seconds. To silence the alarm, press and release the up button.  Appliance cycles 5 min. on, 5 min. off.
E02	Defrost Thermistor Malfunction Alarm  Defrost thermistor has failed.	Call a qualified service technician.  Beeps for 10 seconds, then silent for 50 seconds. To silence the alarm, press and release the up button.  Appliance cycles on and off with cabinet thermistor.
Hi	High Temperature Alarm  <b>Refrigerator:</b> Cabinet temperature has remained above 57°F (13.9°C) for more than 2 hours.  <b>Freezer:</b> Cabinet temperature has remained above 26°F (-3.3°C) for more than 2 hours.	If obvious corrections such as closing doors and cleaning the air filter and/or condenser do not bring temperature back in range, call a qualified service technician.  Beeps for 10 seconds, then silent for 50 seconds. To silence the alarm and clear "Hi" from the display, press and release the up button. The alarm icon stays on.  Automatically resets when temperature returns to normal.
Lo	Low Temperature Alarm  <b>Refrigerator:</b> Cabinet temperature has remained below 26°F (-3.3°C) for more than 2 hours.  <b>Freezer:</b> Cabinet temperature has remained below -23°F (-30.6°C) for more than 2 hours.	If obvious corrections do not bring the temperature back in range, call a qualified service technician.  Beeps for 10 seconds, then silent for 50 seconds. To silence the alarm and clear "Lo" from the display, press and release the up button. The alarm icon stays on.  Automatically resets when temperature returns to normal.

## **H. Safety Devices**

### **1. Compressor External or Internal Overload**

If combined temperature/amperage value is above the limit specified by the compressor manufacturer, the compressor overload operates independently to turn off the compressor. The compressor overload de-energizes the compressor until the temperature/amperage value returns to an acceptable level.

### **2. Short-Cycle Protection**

There is a 2-minute minimum off-time and on-time for the compressor.

Note: Time may vary with compressor overload or high-pressure switch activation.

### **3. High-Pressure Switch**

If pressure on the high-side of the appliance exceeds Hoshizaki specifications, the high-pressure switch activates and interrupts the compressor circuit, de-energizing the compressor until the pressure returns to an acceptable level.

## **I. Cooling Performance**

Be sure the appliance is properly installed and located for optimum cooling performance. If cooling performance is not at its optimum level, check the following items:

- Door(s) opened too often.
- Door(s) left open. Close.
- Dirty air filter and/or condenser. Clean.
- Cabinet too tightly packed or cabinet air inlet/outlet blocked. Allow some space between items to ensure good air flow.
- Warm or hot foods inside. Take them out until they cool down more.
- Ambient temperature too high. Avoid installation near high heat producing equipment or exposure to direct sunlight.
- Temperature setpoint too high. Readjust it to a lower temperature.
- Appliance in defrost cycle. The cabinet temperature may rise temporarily during the defrost cycle, but this will not affect the food inside.

## **J. Cabinet Condensation**

In the event condensation develops on the cabinet exterior, check the following items:

- Door(s) left open. Close.
- Ambient humidity too high. In high humidity areas it may be necessary to wipe off the cabinet frame occasionally.

---

## III. Cleaning and Maintenance Instructions

### A. Cleaning

#### **⚠ WARNING**

- Before cleaning the appliance, press and hold the standby button to turn "OFF" the appliance, unplug the appliance to prevent electric shock by unexpected entrance of water into the appliance or injury by moving parts. To reduce the risk of electric shock, do not touch the plug with damp hands.
- Before cleaning the appliance, move all foods into another clean refrigerator or freezer.
- Do not splash water directly onto the appliance. This might cause short circuit, electric shock, corrosion, or failure.
- Carefully follow instructions provided with cleaning and sanitizing products.

#### **NOTICE**

- To prevent damage to the plastic surfaces, do not use the following: hot water, thinner, benzene, alcohol, petroleum, soap powder, polishing powder, alkaline cleaner, acid, scouring pad and especially those strong cleaners for use on a ventilating fan or a cooking range.
- To prevent corrosion and damage to stainless steel surfaces, use only products formulated for use on stainless steel appliances. Do not use steel wool, abrasive products, or products containing sodium hypochlorite (chlorine bleach).
- Use a clean cloth for cleaning.

#### **1. Exterior**

Wipe the exterior occasionally with a clean, soft cloth. Use a damp cloth containing a neutral cleaner to wipe off oil or dirt buildup. Clean any rust colored spots using a non-abrasive cleanser.

#### **2. Cabinet Interior**

Spills should be wiped up promptly to avoid unpleasant odors. The cabinet interior should be cleaned periodically with a mild soap or detergent and warm water. **NOTICE! Do not use hot water to clean the cabinet interior.**

#### **3. Door Gaskets**

Door gaskets should be cleaned regularly with mild soap and warm water to remove dirt and grease.

#### **4. Shelves**

Remove and clean regularly.

#### **5. Glass Door**

Wipe occasionally with a clean, soft cloth. Use a damp cloth containing a neutral cleaner to wipe off oil or dirt buildup.

## B. Maintenance

The appliance must be maintained in accordance with the instruction manual. Consult with your local Hoshizaki Certified Service Representative about maintenance service. Failure to maintain the appliance in accordance with this manual may adversely affect safety, performance, component life, and warranty coverage.

### ⚠ WARNING

- Only qualified service technicians should service the appliance.
- Press and hold the standby button to turn "OFF" the appliance, unplug the appliance before performing maintenance or troubleshooting to prevent electric shock or injury by moving parts. To reduce the risk of electric shock, do not touch the plug with damp hands.
- Before performing maintenance or troubleshooting, move all foods into another clean refrigerator or freezer.

#### 1. Air Filter

Check the air filter at least twice a month. When clogged, use warm water and a neutral cleaner to wash the filter.

#### 2. Condenser

The condenser must be cleaned at least once a year. More frequent cleaning may be required in some conditions. Use a brush or vacuum cleaner to clean the condenser as required.

#### 3. Condensate Wick (Except DT1A-HS and Freezer on DT2A-FS)

The condensate wick must be cleaned at least once a year. More frequent cleaning may be required in some conditions to maintain proper flow. Follow the steps below.

- 1) Unplug the appliance from the electrical outlet. **WARNING! To reduce the risk of electric shock, do not touch the plug with damp hands.**
- 2) Remove the wick from the retainers. See Fig. 75.
- 3) Clean or replace the wick. **NOTICE! If the wick is clogged/deteriorating replace.**
- 4) Replace the wick in its correct position.  
**NOTICE! Be sure the wick is positioned into the condensate pan.**
- 5) Plug the appliance back in.

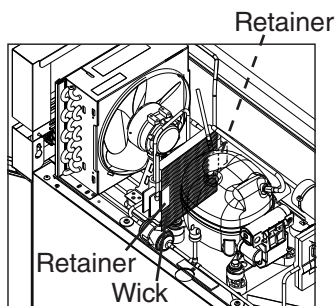
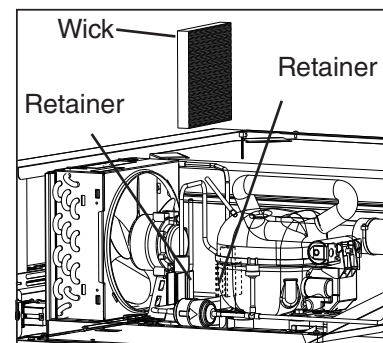


Fig. 75



#### 4. Power Supply Connection

If the plug or power cord is damaged, contact your local Hoshizaki service representative or local Hoshizaki distributor immediately and ask for repairs.

All other maintenance or service on this appliance should be performed in accordance with the Hoshizaki Service Manual by a qualified service technician.

## IV. Preparing the Appliance for Periods of Non-Use

When shutting down the appliance for periods of non-use, follow the instructions below.

### **⚠ WARNING**

- Prevent the doors from closing to reduce the risk of children getting trapped.
- To reduce the risk of electric shock, do not touch the plug with damp hands.

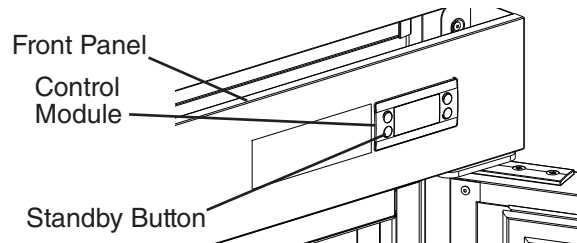
### **NOTICE**

Clean the appliance. See "III.A. Cleaning" for details.

1) Before shutting down the appliance, move the stored food into another refrigerator or freezer.

2) Press and hold the standby button on the control module until "OFF" appears in the display, then unplug the appliance from the electrical outlet. See Fig. 76.

**IMPORTANT! Perimeter heater, mullion heater, and drain tube heater (drain tube heater on freezer models only), energize once appliance is plugged into the electrical outlet and remain energized even while the control module is in "OFF" mode. Unplug the appliance from the electrical outlet to de-energize the heaters.**



**Fig. 76**

## V. Disposal

### **DANGER**

#### **Risk of Fire or Explosion Flammable Refrigerant Used**

- Follow handling instructions carefully in compliance with U.S. government regulations.
- Do not puncture refrigerant tubing. Risk of fire or explosion due to puncture of refrigerant tubing; follow handling instructions carefully.
- Dispose of properly in accordance with federal or local regulations.

#### **Risque De Feu Ou D'Explosion Le Frigorigène Est Inflammable**

- Suivre attentivement les instructions de manipulation conformément à la réglementation gouvernementale.
- Ne pas perforer la tubulure contenant le frigorigène. Risque de feu ou d'explosion si la tubulure contenant le frigorigène est perforée; suivre les instructions de manutention avec soin.
- Éliminer conformément aux règlements fédéraux ou locaux.

### **WARNING**

Remove the door to reduce the risk of children getting trapped. Leave the shelves in place so that children may not easily climb inside.

The appliance contains refrigerant and must be disposed of in accordance with applicable national, state, and local codes and regulations. Refrigerant must be recovered by properly certified service personnel.

**HOSHIZAKI AMERICA, INC.**

618 Hwy. 74 South, Peachtree City, GA 30269 USA (P) 770.487.2331 (F) 770.487.3360 [hoshizakiamerica.com](http://hoshizakiamerica.com) 1A5918-011