



# HOSHIZAKI

## Instruction Manual

Modular Crescent Cuber  
Serenity Series

Models  
KMS-830MLH

Including Unit Models  
SRK-8H3



[hoshizakiamerica.com](http://hoshizakiamerica.com)

Issued: 4-16-2011  
Revised: 8-17-2017

**⚠ WARNING**

Only qualified service technicians should install and service the appliance. To obtain the name and phone number of your local Hoshizaki Certified Service Representative, visit [www.hoshizaki.com](http://www.hoshizaki.com). No installation or service should be undertaken until the technician has thoroughly read this Instruction Manual. Likewise, the owner/manager should not proceed to operate the appliance until the installer has instructed them on its proper operation. Failure to install, operate, and maintain the appliance in accordance with this manual will adversely affect safety, performance, component life, and warranty coverage and may result in costly water damage. Proper installation is the responsibility of the installer. Product failure or property damage due to improper installation is not covered under warranty.

Hoshizaki provides this manual primarily to assist qualified service technicians in the installation, maintenance, and service of the appliance.

Should the reader have any questions or concerns which have not been satisfactorily addressed, please call, send an e-mail message, or write to the Hoshizaki Technical Support Department for assistance.

Phone: 1-800-233-1940; (770) 487-2331

Fax: 1-800-843-1056; (770) 487-3360

E-mail: [techsupport@hoshizaki.com](mailto:techsupport@hoshizaki.com)

**HOSHIZAKI AMERICA, INC.**

618 Highway 74 South

Peachtree City, GA 30269

Attn: Hoshizaki Technical Support Department

**NOTE:** To expedite assistance, all correspondence/communication **MUST** include the following information:

- Model Number \_\_\_\_\_
- Serial Number \_\_\_\_\_
- Complete and detailed explanation of the problem.

## **IMPORTANT**

This manual should be read carefully before the appliance is installed and operated. Read the warnings and guidelines contained in this manual carefully as they provide essential information for the continued safe use and maintenance of the appliance. Retain this manual for any further reference that may be necessary.

## **CONTENTS**

Important Safety Information .....	4
I. Specifications.....	6
A. Electrical and Refrigerant Data .....	6
1. KMS-830MLH.....	6
2. SRK-8/3H .....	6
B. Dimensions/Connections .....	7
1. KMS-830MLH.....	7
2. SRK-8H/3 .....	8
II. Installation and Operating Instructions .....	9
A. Location .....	9
B. Checks Before Installation.....	11
1. Icemaker .....	11
2. Remote Condensing Unit.....	11
C. How to Remove Panels.....	12
1. Icemaker .....	12
2. Remote Condensing Unit.....	12
D. Setup.....	13
1. Dispenser Unit/Ice Storage Bin and Icemaker Setup.....	13
2. Bin Control Installation.....	14
E. Installation of the Remote Condensing Unit.....	15
1. Setup.....	15
2. Line Set .....	15
3. Line Set Installation .....	16
F. Electrical Connection .....	18
G. Water Supply and Drain Connections .....	21
H. Final Checklist.....	23
I. Startup.....	24
III. Maintenance .....	26
A. Maintenance Schedule.....	26
B. Cleaning and Sanitizing Instructions .....	27
IV. Preparing the Icemaker for Periods of Non-Use .....	32
V. Disposal .....	33

---

## Important Safety Information

Throughout this manual, notices appear to bring your attention to situations which could result in death, serious injury, damage to the appliance, or damage to property.

**⚠ WARNING** Indicates a hazardous situation which could result in death or serious injury.

**NOTICE** Indicates a situation which could result in damage to the appliance or property.

**IMPORTANT** Indicates important information about the installation, use, and care of the appliance.

### **⚠ WARNING**

This appliance should be destined only to the use for which it has been expressly conceived. Any other use should be considered improper and therefore dangerous. The manufacturer cannot be held responsible for injury or damage resulting from improper, incorrect, and unreasonable use. Failure to install, operate, and maintain the appliance in accordance with this manual will adversely affect safety, performance, component life, and warranty coverage and may result in costly water damage.

**To reduce the risk of death, electric shock, serious injury, or fire, follow basic precautions including the following:**

- Only qualified service technicians should install and service the appliance.
- The appliance must be installed in accordance with applicable national, state, and local codes and regulations.
- To reduce the risk of electric shock, do not touch the control switch with damp hands.
- Move the control switch to the "OFF" position and turn off the power supply to the remote condensing unit before servicing. Place the icemaker disconnect (if applicable) in the "OFF" position. Lockout/Tagout to prevent the power supply from being turned back on inadvertently.
- Do not make any alterations to the appliance. Alterations could result in electric shock, injury, fire, or damage to the appliance.
- This appliance is not intended for use by persons (including children) with reduced physical, sensory, or mental capabilities, or lack of experience and knowledge, unless they have been given supervision or instruction concerning use of the appliance by a person responsible for their safety.
- Children should be properly supervised around this appliance.
- Do not climb, stand, or hang on the appliance or allow children or animals to do so. Serious injury could occur or the appliance could be damaged.
- Do not use combustible spray or place volatile or flammable substances near the appliance. They might catch fire.
- Keep the area around the appliance clean. Dirt, dust, or insects in the appliance could cause harm to individuals or damage to the appliance.

## **⚠ WARNING, continued**

### **Icemaker**

- Do not connect the icemaker to an external power source. Icemaker power supply and ground connection are supplied from the remote condensing unit via the wire bundle provided with the remote condensing unit.
- Wire bundle routing (conduit) and disconnect (if required) must meet national, state, and local electrical code requirements. Failure to meet these code requirements could result in death, electric shock, serious injury, fire, or damage.
- **THE ICEMAKER MUST BE GROUNDED.** Failure to properly ground the icemaker could result in death or serious injury.

### **Remote Condensing Unit**

- Remote condensing unit electrical connection must be hard-wired and must meet national, state, and local electrical code requirements. Failure to meet these code requirements could result in death, electric shock, serious injury, fire, or damage.
- The remote condensing unit requires an independent power supply of proper capacity. See the nameplate for electrical specifications. Failure to use an independent power supply of proper capacity can result in a tripped breaker, blown fuse, damage to existing wiring, or component failure. This could lead to heat generation or fire.
- **THE REMOTE CONDENSING UNIT MUST BE GROUNDED.** Failure to properly ground the remote condensing unit could result in death or serious injury.

## ***NOTICE***

- Follow the water supply, drain connection, and maintenance instructions carefully to reduce the risk of costly water damage.
- In areas where water damage is a concern, install in a contained area with a floor drain.
- Install the icemaker in a location that stays above freezing. Normal operating ambient temperature must be within 45°F to 100°F (7°C to 38°C).
- Do not leave the icemaker on during extended periods of non-use, extended absences, or in sub-freezing temperatures. To properly prepare the icemaker for these occasions, follow the instructions in "IV. Preparing the Icemaker for Periods of Non-Use."
- Do not place objects on top of the appliance.
- The dispenser unit/ice storage bin is for ice use only. Do not store anything else in the dispenser unit/ice storage bin.

---

## I. Specifications

### A. Electrical and Refrigerant Data

The rating label (KMS) and nameplate (KMS and SRK) provide electrical and refrigerant data. The rating label can be seen by removing the front panel. The nameplate is located on the rear panel of the icemaker and on the side panel of the remote condensing unit. For certification marks, see the nameplate.

We reserve the right to make changes in specifications and design without prior notice.

#### 1. KMS-830MLH

<b>Model Number</b>	<b>KMS-830MLH</b>
AC Supply Voltage	115-120/60/1
Pump	120V 0.5FLA 10W
Other	115V 0.8A
Design Pressure	HI-467PSI LO-230PSI
Total Refrigerant Charge	404A Total Refrigerant Charge with Hoshizaki Remote Condensing Unit SRK-8H/3: 13 LB. 9 OZ.

#### 2. SRK-8/3H

<b>Model Number</b>	<b>SRK-8H</b>	<b>SRK-8H3</b>
AC Supply Voltage	208-230/60/1 (3 wire with neutral for 115V)	208-230/60/3
Compressor	208-230V 7.7RLA 56LRA	208-230V 5.7RLA 51LRA
Fan	115V 1.3FLA 65W	115V 1.3FLA 65W
Other	115V 0.4A	115V 0.4A
Maximum Fuse Size	20 AMPS	20 AMPS
Max. HACR Breaker (USA Only)	20 AMPS	20 AMPS
Max. Circ. Breaker (Canada Only)	20 AMPS	20 AMPS
Minimum Circuit Ampacity	20 AMPS	20 AMPS
Design Pressure	HI-467PSI LO-230PSI	HI-467PSI LO-230PSI
Refrigerant	404A Total Refrigerant Charge with Hoshizaki Icemaker KMS-830MLH: 13 LB. 9 OZ.	404A Total Refrigerant Charge with Hoshizaki Icemaker KMS-830MLH: 13 LB. 9 OZ.

# B. Dimensions/Connections

## 1. KMS-830MLH

Unit: mm [in.]

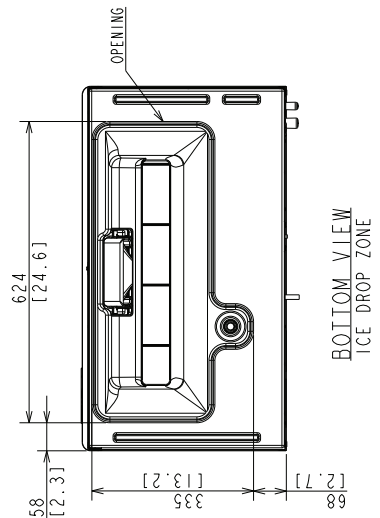
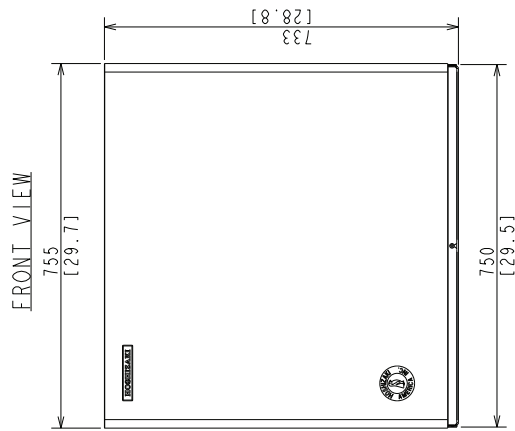
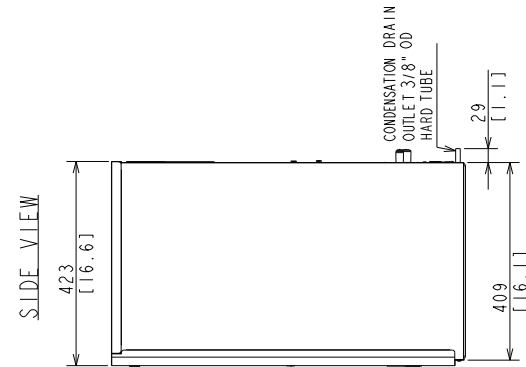
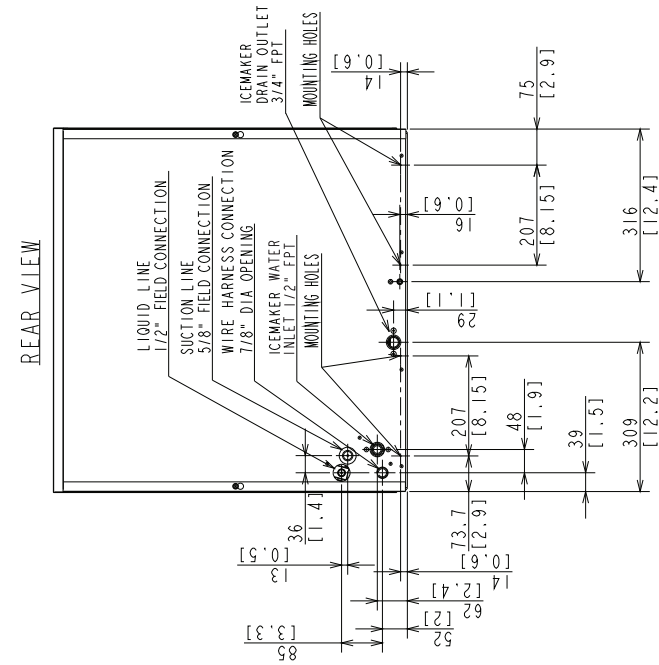

2. SRK-8H/3

Unit: mm [in.]

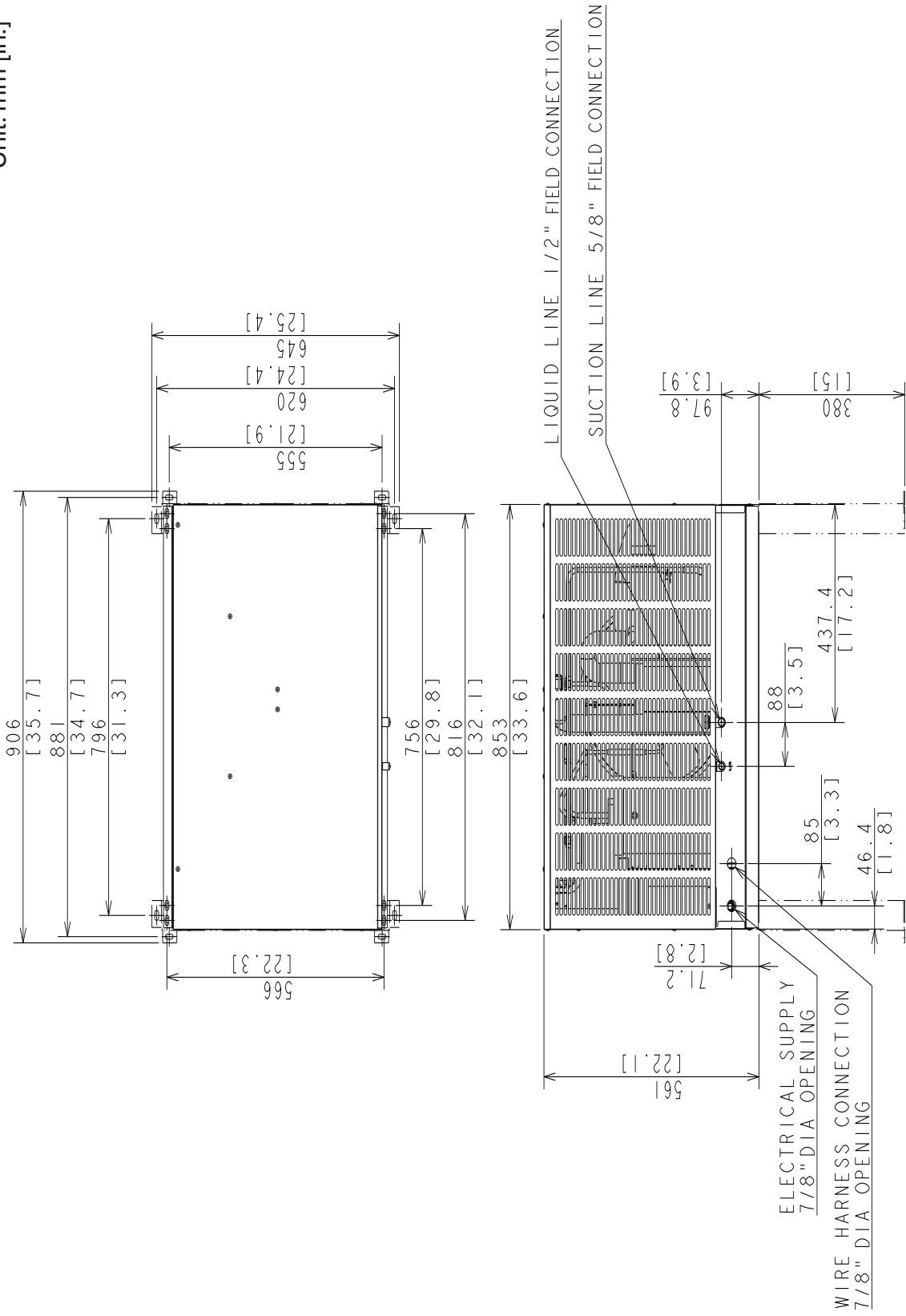

Note: Legs are included with remote condensing unit.  
Leg height is 380 mm (14.96 in.).

---

## II. Installation and Operating Instructions

### **⚠ WARNING**

- The icemaker and remote condensing unit must be installed in accordance with applicable national, state, and local codes and regulations.
- Failure to install, operate, and maintain the appliance in accordance with this manual will adversely affect safety, performance, component life, and warranty coverage and may result in costly water damage.
- **CHOKING HAZARD:** Ensure all components, fasteners, and thumbscrews are securely in place after installation. Make sure that none have fallen into the dispenser unit/ice storage bin.

## A. Location

### 1. Icemaker

#### **NOTICE**

- This icemaker is not intended for outdoor use. Normal operating ambient temperature must be within 45°F to 100°F (7°C to 38°C); Normal operating water temperature must be within 45°F to 90°F (7°C to 32°C). Operation of the icemaker, for extended periods, outside of these normal temperature ranges may affect icemaker performance.
- This icemaker will not work at sub-freezing temperatures. To prevent damage to the water supply line, drain the icemaker if the air temperature is going to go below 32°F (0°C). See "IV. Preparing the Icemaker for Periods of Non-Use."

- The icemaker should not be located next to ovens, grills, or other high heat producing equipment.
- Allow 6" (15 cm) clearance at rear, right side, and top for proper air circulation and ease of maintenance and/or service should they be required. Allow 28" (71 cm) clearance on left side for removal of cube guides.
- The location must provide a firm and level foundation for the equipment.

## 2. Remote Condensing Unit

### NOTICE

- The remote condensing unit is intended for outdoor use. Normal operating ambient temperature must be within -20°F to 122°F (-29°C to 50°C). Operation of the remote condensing unit, for extended periods, outside of this normal temperature range may affect performance.
- The maximum line set length is 66' (20 m). No refrigerant charge adjustment is necessary.
- The maximum vertical distance between the remote condensing unit and icemaker is 33' (10 m) above or 10' (3 m) below the icemaker. These distances are measured fitting to fitting. See Fig. 1.
- If the vertical distance between the remote condensing unit and the icemaker is greater than 20' (6 m) (not to exceed 33' (10 m)), an "S" oil-trap (5/8" OD copper tubing) must be installed in the suction line. The "S" oil-trap must be located halfway between the icemaker and remote condensing unit. This ensures sufficient oil return to the compressor.

The remote condensing unit must be positioned in a permanent site under the following guidelines:

- A firm and flat site.
- A dry and well ventilated area with 24" (61 cm) clearance in both front and rear for proper air circulation and ease of maintenance and/or service should they be required. See Fig. 2.

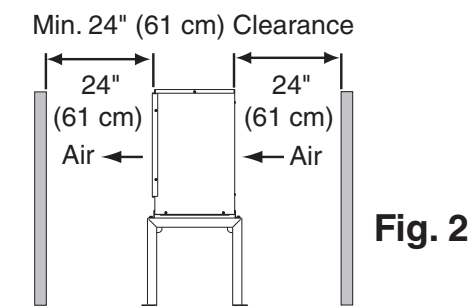
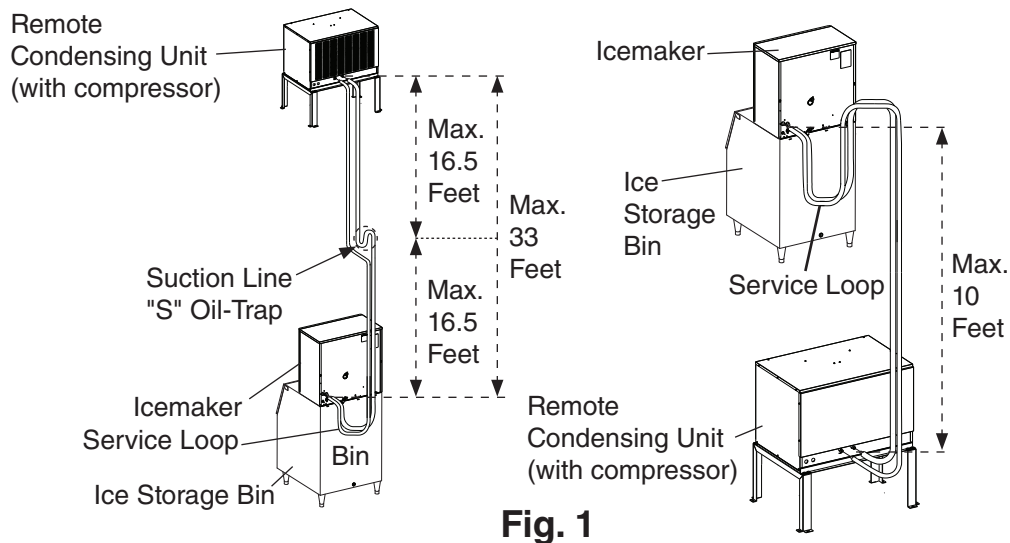

## B. Checks Before Installation

- Visually inspect the exterior of the shipping containers and immediately report any damage to the carrier. Upon opening the containers, any concealed damage should also be immediately reported to the carrier.
- Remove the shipping carton, tape, and packing material. If any are left in the icemaker or remote condensing unit, they will not work properly.

### 1. Icemaker

- Remove the panels to prevent damage when installing the icemaker. See "II.C. How to Remove Panels."
- Remove the package containing the accessories.
- Remove the protective plastic film from the panels. If the icemaker is exposed to the sun or to heat, remove the film after the icemaker cools.
- Check that the refrigerant lines do not rub or touch lines or other surfaces.
- This icemaker can be installed on a dispenser unit or ice storage bin 30" wide or wider. For options, contact your local Hoshizaki distributor.
- **NOTICE! This icemaker is designed for connection to Hoshizaki Remote Condensing Unit Model SRK-8H or SRK-8H3 only! Connection to another remote condensing unit will void the warranty.**

### 2. Remote Condensing Unit

- See the nameplate on the remote condensing unit. Check that your voltage supplied corresponds with the voltage specified on the nameplate.
- Remove the panels to prevent damage when installing the remote condensing unit. See "II.C. How to Remove Panels."
- Remove the package containing the accessories.
- Check that the refrigerant lines do not rub or touch lines or other surfaces, and that the fan blade turns freely.
- Check that the compressor is snug on all mounting pads.

## C. How to Remove Panels

### 1. Icemaker

- Front Panel: Remove the screw. Lift up and towards you.
- Control Box Cover: Remove the screw and pull towards you.
- Top Panel: Lift off.
- Top Insulation Panel: Lift off.
- Side Panels: Lift the rear edge off of the rear taper collar. Slide to rear and lift off.
- Insulation Panel: Lift up slightly and pull towards you.

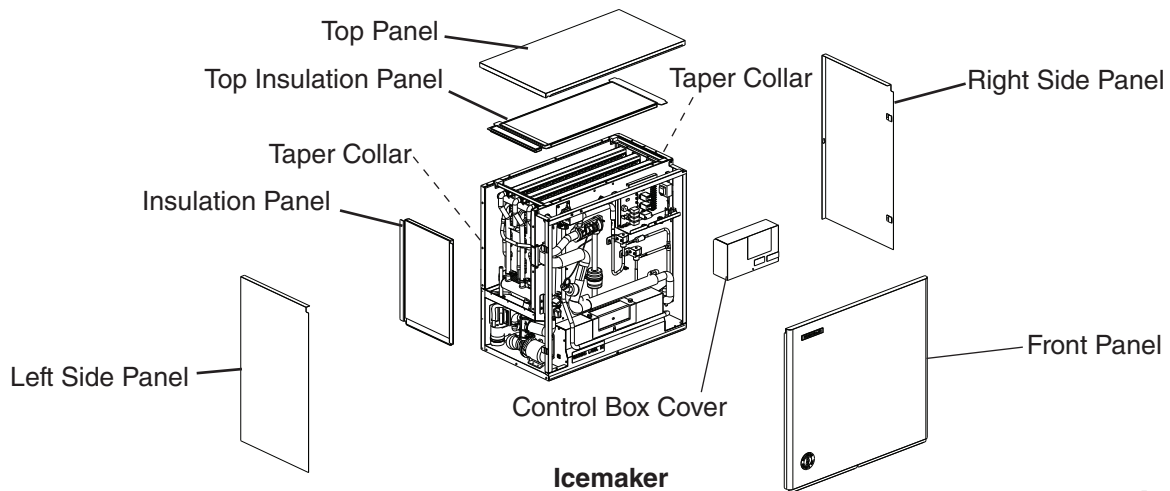

Fig. 3

### 2. Remote Condensing Unit

- Top Panel: Remove the screws and lift off.
- Louver Panel: Remove the screws and lift off.
- Side Panels: Remove the screws and lift off.
- Front Frame: Remove the screws and lift off.
- Control Box Cover: Remove the screws and lift off.

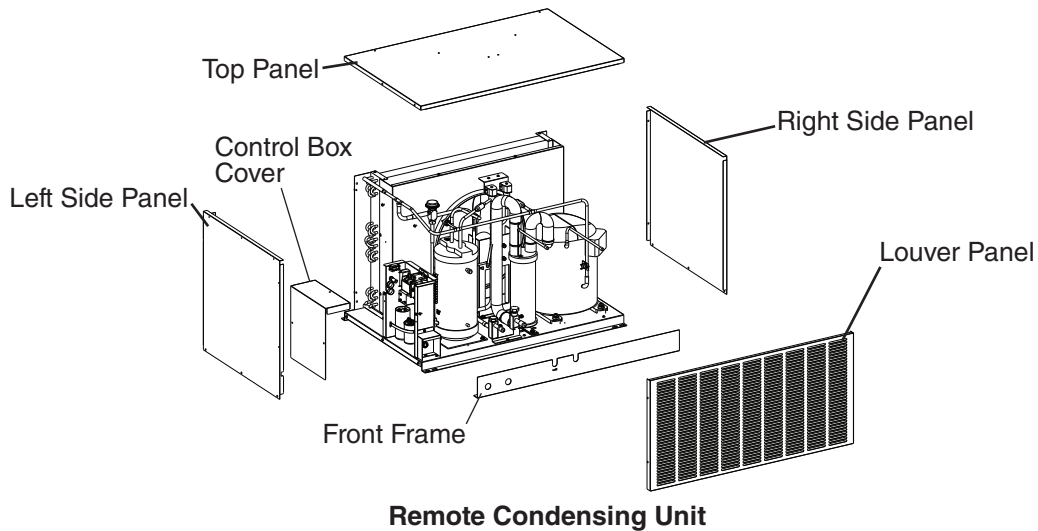

Fig. 4

## D. Setup

### 1. Dispenser Unit/Ice Storage Bin and Icemaker Setup

#### ⚠ WARNING

The installer must ensure the dispenser unit/ice storage bin is compatible with the icemaker, and the dispenser unit/ice storage bin and icemaker are properly attached and secured.

#### NOTICE

- Do not connect the icemaker to an external power source. Icemaker power supply and ground connection are supplied from the remote condensing unit via the wire bundle provided with the remote condensing unit. For details, see "II.F. Electrical Connection."
- Before operating the icemaker, the bin control must be installed correctly. Failure to properly install the bin control could result in ice backup and unit damage.

- 1) If mounting the icemaker on top of a dispenser unit, follow the dispenser unit's setup procedure. If mounting the icemaker on top of an ice storage bin, unpack the ice storage bin and attach the 4 adjustable legs provided (bin accessory) to the bottom of the ice storage bin.
- 2) Position the dispenser unit/ice storage bin in its permanent location.
- 3) If required, install an adapter kit or top kit. Contact your local Hoshizaki distributor for recommendations.
- 4) Level the dispenser unit/ice storage bin in both the left-to-right and front-to-rear directions. If using an ice storage bin, adjust the ice storage bin legs to level.
- 5) Place the icemaker on top of the dispenser unit/ice storage bin.
- 6) Secure the icemaker to the dispenser unit/ice storage bin using the mounting brackets and bolts provided. See Fig. 5.

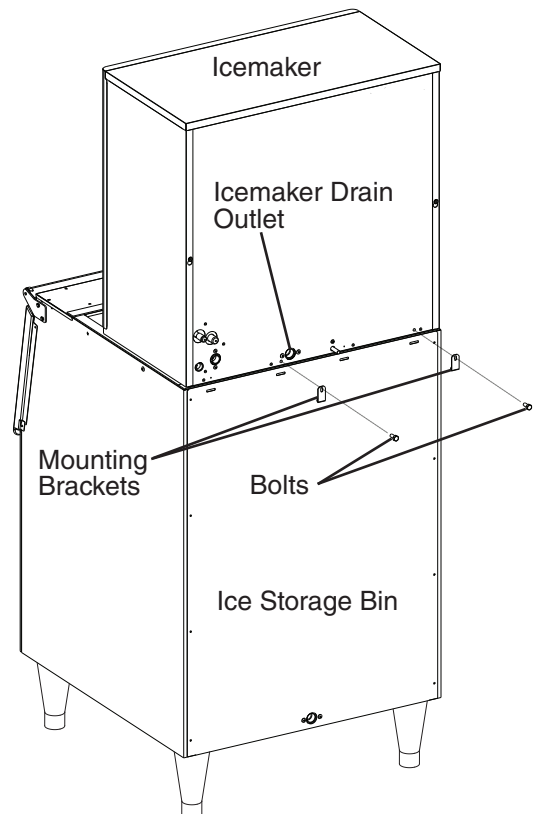

**Fig. 5**

## 2. Bin Control Installation

### **NOTICE**

Before operating the icemaker, the bin control must be installed. Failure to properly install the bin control could result in ice backup and icemaker damage.

Follow the instructions below for bin control assembly installation.

- 1) Remove the front panel.
- 2) Remove the bin control insulation and bin control cover. See Fig. 6.
- 3) Remove the bin control from the bin control cover.
- 4) Remove the bin control extension bracket and 2 thumbscrews from the accessory bag. Route the bin control cable around one of the notches on either side of the extension bracket, then secure the bin control to the bin control extension bracket using the 2 thumbscrews. See Fig. 7.  
Note: All thumbscrews used in the bin control assembly are the same size.
- 5) Using 2 existing thumbscrews, attach the bin control extension bracket to the bin control cover.
- 6) Route the bin control cable through the slot in the bin control cover, then place the bin control assembly into position and secure with 2 existing thumbscrews.
- 7) Replace the bin control insulation in its proper position.

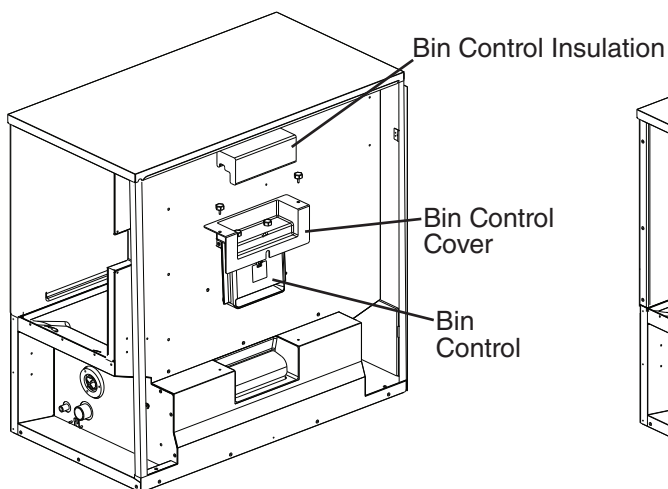

**Fig. 6**

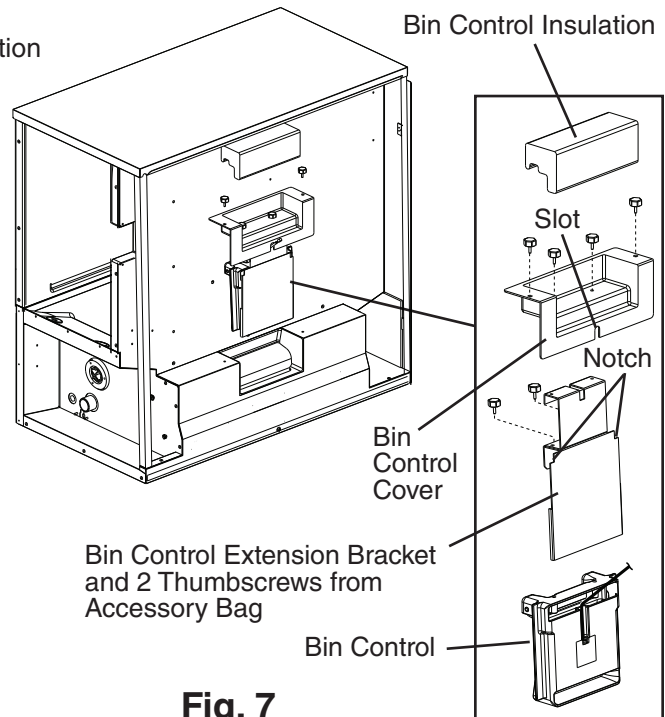

**Fig. 7**

## E. Installation of the Remote Condensing Unit

### ⚠ WARNING

- Installation must be performed by properly trained and EPA-certified service personnel.
- Power supply and ground wire to the icemaker are supplied from the remote condensing unit. For details, see "II.F. Electrical Connection."

### 1. Setup

- 1) Secure the legs to the remote condensing unit with the 8 bolts and nuts provided. See Fig. 8.
- 2) The legs have 8 mounting holes. Secure the legs with 8 bolts (not included).

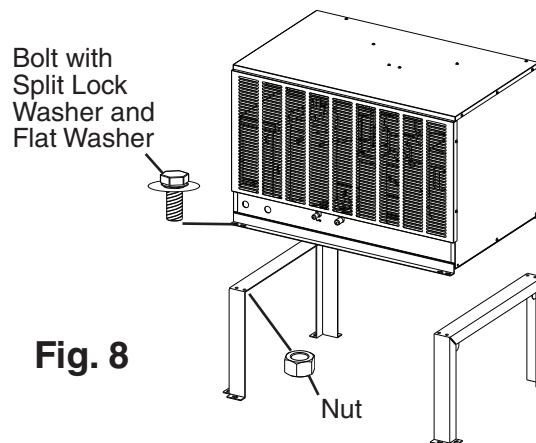

Fig. 8

### 2. Line Set

### NOTICE

- The icemaker, line set, and remote condensing unit must contain the same type of refrigerant. Mixing of refrigerants will result in improper operation and possible damage to the refrigeration system.
- The maximum line set length is 66' (20 m). No refrigerant charge adjustment is necessary.
- The maximum vertical distance between the remote condensing unit and icemaker is 33' (10 m) above or 10' (3 m) below the icemaker. These distances are measured fitting to fitting. See Fig. 9.
- If the vertical distance between the remote condensing unit and the icemaker is greater than 20' (6 m) (not to exceed 33' (10 m)), an "S" oil-trap (5/8" OD copper tubing) must be installed in the suction line. The "S" oil-trap must be located halfway between the icemaker and remote condensing unit. This ensures sufficient oil return to the compressor.

Line Set Size and Length for SRK-8H/3 Remote Condensing Units				
Hoshizaki Icemaker	Liquid Line	Suction Line	Factory Line Set Lengths	Maximum Line Set Length
KMS-830MLH	1/2" OD	5/8" OD	25' (7.6 m), 35' (10.7 m), and 55' (16.8 m)	66' (20 m)

### 3. Line Set Installation

#### **WARNING**

- R-404A itself is not flammable at atmospheric pressure and temperatures up to 176°F (80°C).
- R-404A itself is not explosive or poisonous. However, when exposed to high temperatures (open flames), R-404A can be decomposed to form hydrofluoric acid and carbonyl fluoride both of which are hazardous.
- Do not use silver alloy or copper alloy containing arsenic.
- Do not open any service valve until the line set installation is complete and leak tested.
- Ensure that there are no unnecessary traps and no kinks in the line set.
- Do not coil extra line set.
- Use an electronic leak detector or soap bubbles to check for leaks. Add a trace of refrigerant to the line set tubing through the service valve access ports (if using an electronic leak detector), and then raise the pressure using nitrogen gas (140 PSIG). Do not use R-404A as a mixture with pressurized air for leak testing.

- 1) Route the factory line set or appropriate size copper tubing. When field fabricating, insulate the copper tubes separately. Leave a service loop behind the icemaker to allow the icemaker to be pulled out for service. See Fig. 9. Note: The service loop is not considered an oil trap.
- 2) Remove any extra line set length.
- 3) **NOTICE! Before brazing, remove the Schrader valve cores from the service valve access ports. When brazing, protect the service valve by using a wet cloth to prevent the service valve from overheating.**
- 4) Braze the line set to the icemaker service valves first, then to the remote condensing unit service valves.
- 5) Allow the service valves to cool, then replace the Schrader valve cores.
- 6) Use an electronic leak detector or soap bubbles to check for leaks. Add a trace of refrigerant to the line set tubing through the service valve access ports (if using an electronic leak detector), and then raise the pressure using nitrogen gas (140 PSIG).  
**WARNING! Do not use R-404A as a mixture with pressurized air for leak testing.**
- 7) Attach the gauge manifold hoses to the service valve access ports and evacuate the line set tubing. Allow the vacuum pump to pull down to a 29.9" Hg vacuum. Evacuating period depends on pump capacity. Next, charge each line set tube with R-404A vapor to a pressure of 15 to 30 PSIG.
- 8) Close both gauge manifold valves.
- 9) Disconnect the gauge manifold hoses.
- 10) Replace the access port caps and tighten.
- 11) Open the icemaker service valves first, then open the remote condensing unit service valves.
- 12) Replace the service valve caps and tighten.

- 13) Insulate all exposed tubing and fittings.  
 Hoshizaki Technical Support is available at 1-800-233-1940 for recommendations

### Line Set Connections

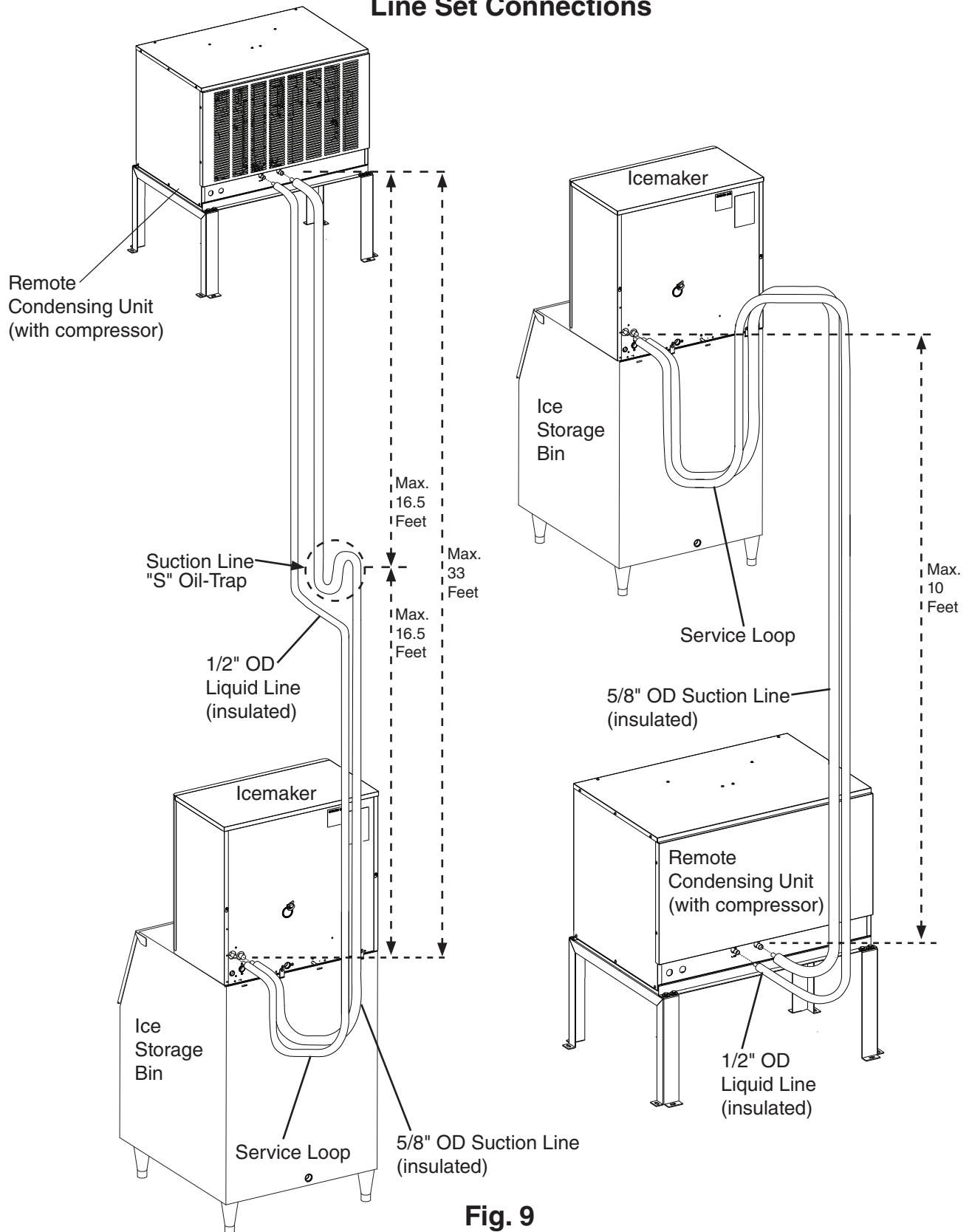

**Fig. 9**

## F. Electrical Connection

### **⚠ WARNING**

#### **Icemaker**

- Do not connect the icemaker to an external power source. Icemaker power supply and ground connection are supplied from the remote condensing unit via the wire bundle provided with the remote condensing unit.
- Wire bundle routing (conduit) and disconnect (if required) must meet national, state, and local electrical code requirements. If fabricating a wire bundle, use wire of an appropriate gage and outdoor rating. Failure to meet these code requirements could result in death, electric shock, serious injury, fire, or damage.
- **THE ICEMAKER MUST BE GROUNDED.** Failure to properly ground the icemaker could result in death or serious injury.
- To reduce the risk of electric shock, do not connect the remote condensing unit power supply until after all wire bundle connections have been made.

#### **Remote Condensing Unit**

- Remote condensing unit electrical connection must be hard-wired and must meet national, state, and local electrical code requirements. Failure to meet these code requirements could result in death, electric shock, serious injury, fire, or damage.
- The remote condensing unit requires an independent power supply of proper capacity. See the nameplate for electrical specifications. Failure to use an independent power supply of proper capacity can result in a tripped breaker, blown fuse, damage to existing wiring, or component failure. This could lead to heat generation or fire.
- **THE REMOTE CONDENSING UNIT MUST BE GROUNDED.** Failure to properly ground the remote condensing unit could result in death or serious injury.
- Remote condensing unit electrical connection must be made in accordance with the instructions on the "WARNING" tag provided with the pig tail leads in the remote condensing unit's power supply junction box. See Figs. 10a and 10b.

### **NOTICE**

The remote condensing unit must have power for a minimum of 4 hours prior to startup to prevent compressor damage.

- Usually an electrical permit and services of a licensed electrician are required.
- The maximum allowable voltage variation is  $\pm 10$  percent of the nameplate rating.
- The openings for the power supply and wire bundle connections are 7/8" DIA to fit a 1/2" trade size conduit.

- 1) Route the wire bundle between the icemaker and remote condensing unit. Use the wire bundle supplied with the remote condensing unit, or fabricate a wire bundle using wire of an appropriate gage and outdoor rating. Use the wiring label or Fig. 11 as a reference.
- 2a) Icemaker: Connect the wire bundle ground wire to the icemaker ground screw, then connect the rest of the wire bundle wires to the icemaker terminal block.  
**WARNING! Do not connect the wire bundle ground wire to the icemaker terminal block.**
- 2b) Remote Condensing Unit: Connect the wire bundle ground wire to the remote condensing unit ground screw (located next to the terminal block).  
**WARNING! Do not connect the wire bundle ground wire to the remote condensing unit terminal block.**
- 3) Connect the power supply from the disconnect or electrical panel to the leads in the remote condensing unit's power supply junction box. This differs from KM style installations. Connect a ground wire to the ground screw. See Figs. 10a and 10b.
  - On single phase models, the white lead must be connected to the neutral conductor of the power source. **NOTICE! Miswiring may result in severe damage to the icemaker.**
  - On three phase models, the transformer's voltage tap switch must be positioned to match incoming voltage at startup.
  - **NOTICE! On three phase models, connect the highest incoming voltage supply ("stinger leg") to the power wire dedicated to the compressor. See the wiring label on the remote condensing unit.**
- 4) Replace all removed parts and panels in their correct positions.
- 5) Turn on the power supply to the remote condensing unit. **NOTICE! The remote condensing unit must have power for a minimum of 4 hours prior to startup to prevent compressor damage.**

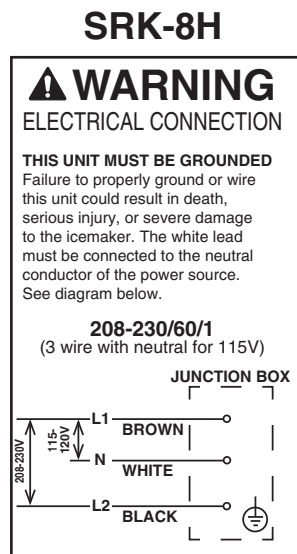

**Fig. 10a**

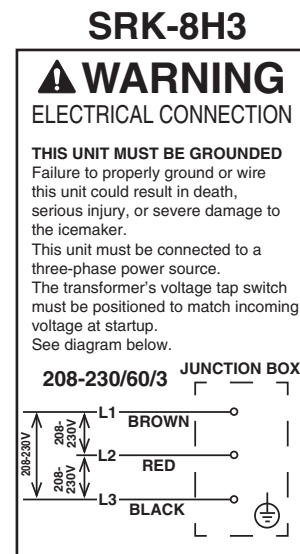
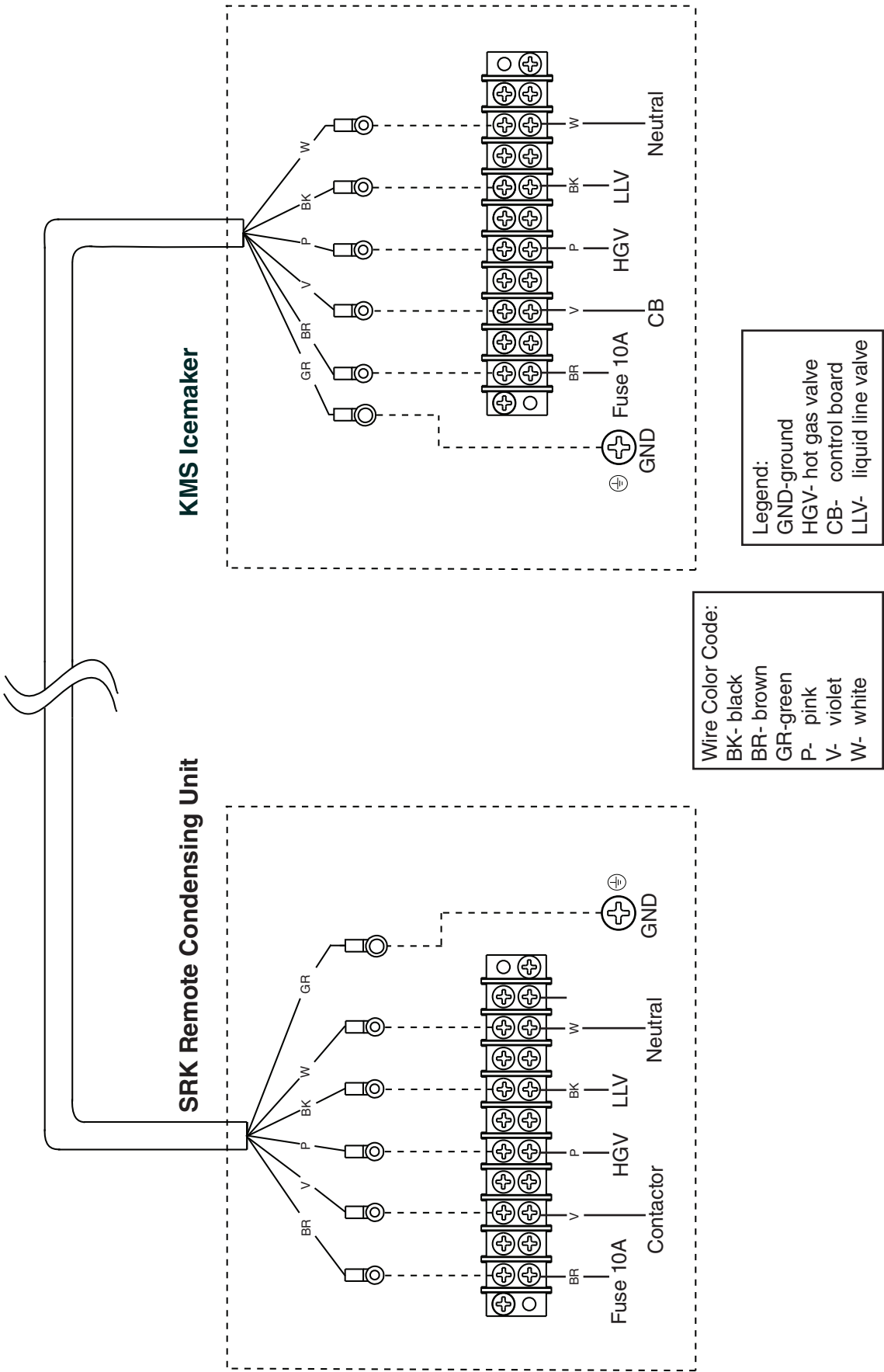

**Fig. 10b**

**Fig. 11**

**Icemaker-Remote Condensing Unit Wire Bundle Connections**

Use wire bundle supplied with the Remote Condensing Unit or fabricate a wire bundle using wire of an appropriate gage and outdoor rating.



## G. Water Supply and Drain Connections

See Fig. 12

### **⚠ WARNING**

Water supply and drain connections must be installed in accordance with applicable national, state, and local regulations.

### **NOTICE**

- Normal operating water temperature should be within 45°F to 90°F (7°C to 32°C). Operation of the icemaker, for extended periods, outside of this normal temperature range may affect performance.
- To prevent damage to equipment, do not operate the icemaker when the water supply is off, or if the pressure is below 10 PSIG. Do not run the icemaker until the proper water pressure is reached.

- A plumbing permit and services of a licensed plumber may be required in some areas.
- External filters, strainers, or softeners may be required depending on water quality. Contact your local Hoshizaki distributor for recommendations.
- Water supply pressure must be a minimum of 10 PSIG and a maximum of 113 PSIG. If the pressure exceeds 113 PSIG, the use of a pressure reducing valve is required.
- The icemaker drain line and dispenser unit/ice storage bin drain line must be run separately.
- Drain lines must have 1/4" fall per foot (2 cm per 1 m) on horizontal runs to get a good flow. A vented tee connection is also required for proper flow.
- Drain lines should not be piped directly to the sewer system. An air gap of a minimum of 2 vertical inches (5 cm) should be between the end of the drain pipes from the icemaker and dispenser unit/ice storage bin and the floor drain.

# 1. Icemaker

Icemaker Water Supply Inlet	Minimum Icemaker Water Supply Line Size	Icemaker Drain Outlet	Minimum Icemaker Drain Line Size
1/2" Female Pipe Thread (FPT)	1/4" Nominal ID Copper Water Tubing or Equivalent	3/4" Female Pipe Thread (FPT)	3/4" Nominal ID Hard Pipe or Equivalent

- An icemaker water supply line shut-off valve and drain valve must be installed.
- Be sure there is sufficient extra water supply line and drain line for the appliance to be pulled out for service.

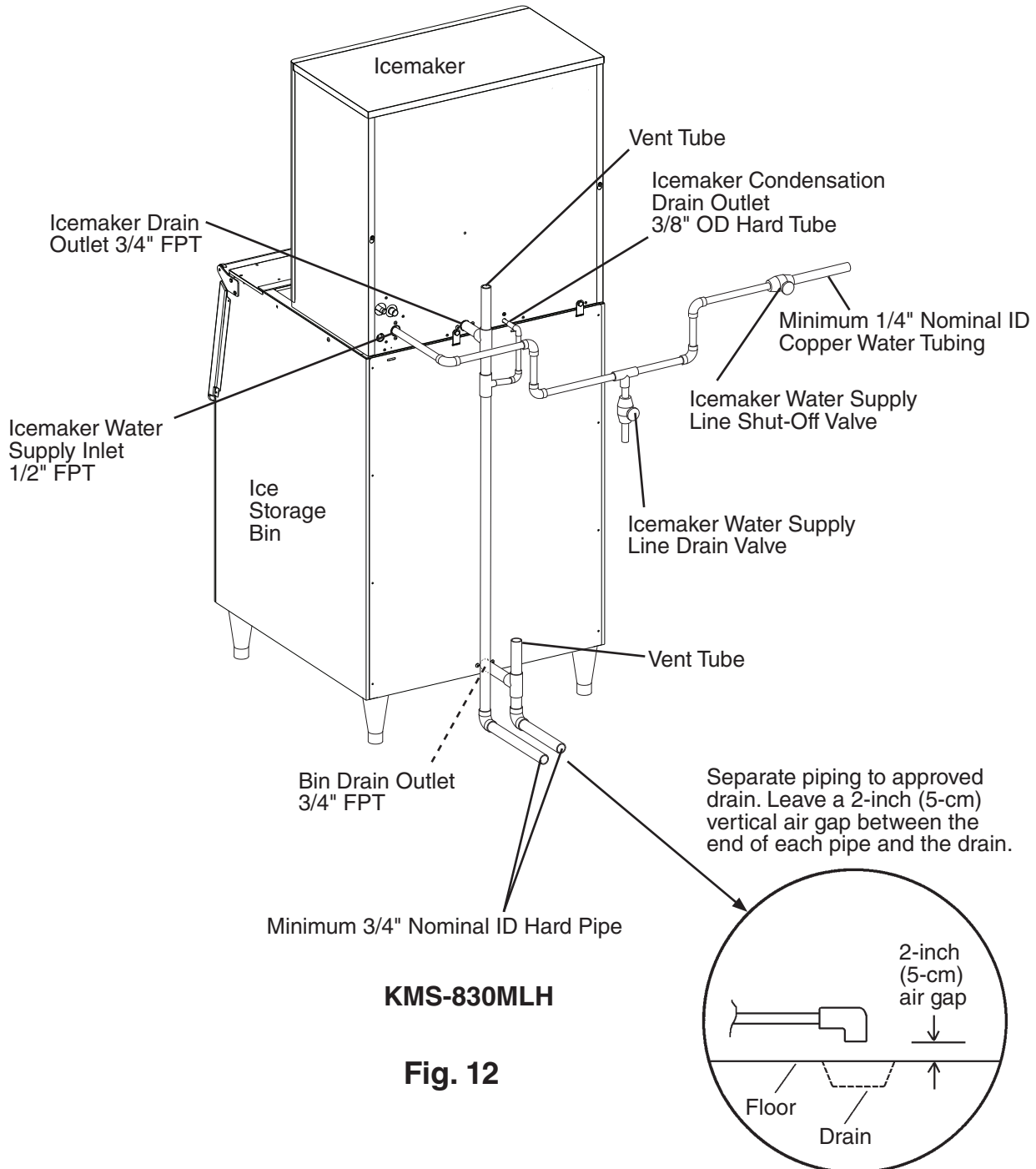

## H. Final Checklist

### WARNING

**CHOKING HAZARD:** Ensure all components, fasteners, and thumbscrews are securely in place after installation. Make sure that none have fallen into the dispenser unit/ice storage bin.

- 1) Is the icemaker level?
- 2) Is the icemaker in a site where the ambient temperature is within 45°F to 100°F (7°C to 38°C) and the water temperature within 45°F to 90°F (7°C to 32°C) all year around?
- 3) Is there at least 6" (15 cm) clearance at rear, right side, and top of the icemaker for proper air circulation and ease of maintenance and service? Is there at least 28" (71 cm) clearance on left side for removal of cube guides?
- 4) Is the remote condensing unit in a site where the ambient temperature is within -20°F to 122°F (-29°C to 50°C) all year around?
- 5) Is there at least 24" (61 cm) clearance around the remote condensing unit for proper air circulation and ease of maintenance and service?
- 6) Have the shipping carton, tape, and packing material been removed from the icemaker and remote condensing unit? Are the cube guides in their correct positions?
- 7) Has the bin control assembly been properly installed?
- 8) Have all electrical and water connections been made? Do electrical and water connections meet all national, state, and local code and regulation requirements?
- 9) Has the power supply voltage been checked or tested against the nameplate rating? Has a proper ground been installed to the remote condensing unit and icemaker unit? On three phase models, has the transformer's voltage tap switch been positioned to match incoming voltage? For details, see "II.F. Electrical Connection."
- 10) Has the electrical power supply been on to the remote condensing unit for a minimum of 4 hours?
- 11) Are the water supply and drain lines sized as specified? Are the water supply line shut-off valve and drain valve installed? Has the water supply pressure been checked to ensure a minimum of 10 PSIG and a maximum of 113 PSIG?
- 12) Is the compressor snug on all mounting pads? Have the refrigerant lines been checked to make sure they do not rub or touch other lines or surfaces? Has the fan blade been checked to make sure it turns freely?
- 13) Is the line set free of leaks and kinks? If needed, has an "S" oil-trap been installed?
- 14) Are all components, fasteners, and thumbscrews securely in place?
- 15) Has the end user been given the instruction manual, and instructed on how to operate the icemaker and the importance of the recommended periodic maintenance?
- 16) Has the end user been given the name and telephone number of an authorized service agent?
- 17) Has the warranty card been filled out and forwarded to the factory for warranty registration?

## I. Startup

### **⚠ WARNING**

All parts are factory-adjusted. Improper adjustments may adversely affect safety, performance, component life, and warranty coverage.

### **NOTICE**

- If the appliance is turned off, wait for at least 3 minutes before restarting the appliance to prevent damage to the compressor.
- To prevent damage to the water pump, do not leave the control switch in the "WASH" position when the water tank is empty.
- At startup, confirm that all internal and external connections are free of leaks.
- The remote condensing unit must have power for a minimum of 4 hours prior to startup to prevent compressor damage.

- 1) Open the water supply line shut-off valve.
- 2) Remove the front panel.
- 3) Move the control switch to the "ICE" position.
- 4) Replace the front panel in its correct position.
- 5) Turn on the power supply, and allow the icemaker to operate for a total of 10 minutes.
- 6) Turn off the power supply, then remove the front panel. Move the control switch to the "OFF" position.
- 7) Remove the top and left side panels, then remove the insulation panel.
- 8) Disconnect the distributor from the distribution hose. Remove the thumbscrew securing cube guide B. Remove cube guide B and cube guide A. See Fig. 13.

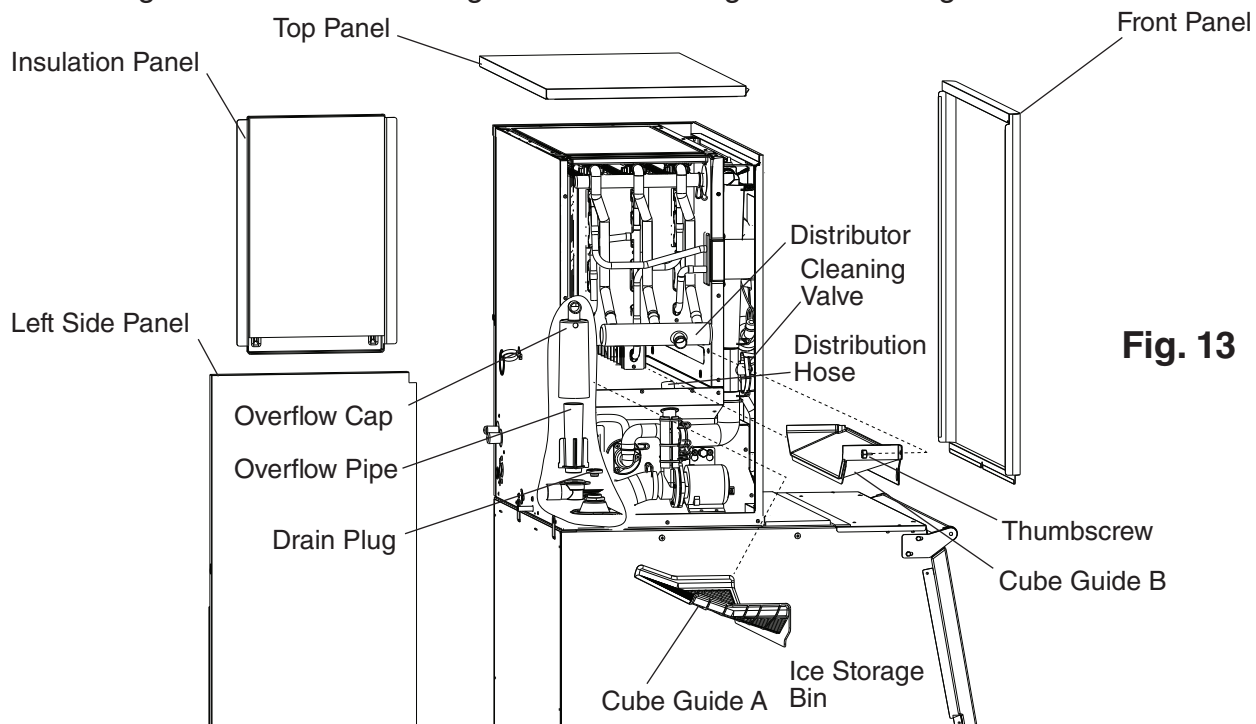

**Fig. 13**

- 9) Remove the overflow cap and overflow pipe.
- 10) Remove the drain plug. Allow the water tank to drain, then replace the drain plug in its correct position. Be careful not to cross thread it.
- 11) Replace the overflow pipe, overflow cap, cube guide A, and cube guide B in their correct positions. Be careful not to cross thread the overflow pipe.
- 12) Reconnect the distributor to the distribution hose.
- 13) Replace the insulation panel, then replace the left side panel and top panel in their correct positions.
- 14) Clean the dispenser unit/storage bin liner using a neutral cleaner. Rinse thoroughly after cleaning.
- 15) Move the control switch to the "ICE" position.
- 16) Turn on the power supply to start the automatic icemaking process.
- 17) To confirm bin control operation, press and hold the bin control's actuator paddle during the first 5 minutes of the freeze cycle. The icemaker should shut down in approximately 15 seconds.
- 18) Replace the front panel in its correct position.

### III. Maintenance

The appliance must be maintained in accordance with the instruction manual and labels provided. Consult with your local Hoshizaki Certified Service Representative about maintenance service.

#### ⚠ WARNING

- Only qualified service technicians should service the appliance.
- To reduce the risk of electric shock, do not touch the control switch with damp hands.
- Move the control switch to the "OFF" position and turn off the power supply before servicing. Lockout/Tagout to prevent the power supply from being turned back on inadvertently.
- **CHOKING HAZARD:** Ensure all components, fasteners, and thumbscrews are securely in place after any maintenance is done to the appliance. Make sure that none have fallen into the dispenser unit/ice storage bin.

### A. Maintenance Schedule

The maintenance schedule below is a guideline. More frequent maintenance may be required depending on water quality, the appliance's environment, and local sanitation regulations.

Maintenance Schedule		
Frequency	Area	Task
Daily	Scoop	Clean the ice scoop using a neutral cleaner. Rinse thoroughly after cleaning.
Monthly	External Water Filters	Check for proper pressure and change if necessary.
	Icemaker Exterior	Wipe down with a clean, soft cloth. Use a damp cloth containing a neutral cleaner to wipe off oil or dirt build up. Clean any chlorine staining (rust colored spots) using a non-abrasive cleanser.
	Underside of Icemaker and Top Kits; Bin Door and Snout	Wipe down with a clean cloth and warm water.
Yearly	Icemaker and Dispenser Unit/Ice Storage Bin	Clean and sanitize per the cleaning and sanitizing instructions provided in this manual. See "III.B. Cleaning and Sanitizing Instructions."
	Water Supply Inlet	Close the icemaker water supply line shut-off valve and drain the water system. Clean the water supply inlet screen.
	Condenser	Inspect. Clean if necessary by using a brush or vacuum cleaner. More frequent cleaning may be required depending on location.
	Water Hoses	Inspect the water hoses and clean/replace if necessary.

## B. Cleaning and Sanitizing Instructions

The icemaker must be cleaned and sanitized at least once a year. More frequent cleaning and sanitizing may be required in some water conditions.

### ⚠ WARNING

- To prevent injury to individuals and damage to the icemaker, do not use ammonia type cleaners.
- Carefully follow any instructions provided with the bottles of cleaning and sanitizing solution.
- Always wear liquid-proof gloves and goggles to prevent the cleaning and sanitizing solutions from coming into contact with skin or eyes.
- Do not leave the icemaker unattended when panels are off.

### NOTICE

To prevent damage to the water pump seal, do not leave the control switch in the "WASH" position for extended periods when the water tank is empty.

### IMPORTANT

- The cleaning valve is opened during cleaning and sanitizing to allow solution flow to the inside of the evaporator. It should be closed for all icemaking operation. The compressor will not operate unless this valve is completely closed.
- To close the cleaning valve, the valve handle should be at a right angle to the valve body. To open the cleaning valve, the valve handle should be parallel to the valve body.

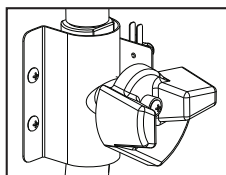

**CLOSED**  
Icemaking Operation

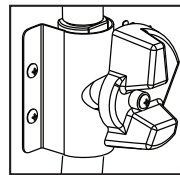

**OPEN**  
Cleaning and Sanitizing Operation  
(allows solution flow to the inside of the evaporator)

### Preparation

- 1) Remove the front panel, then move the control switch to the "OFF" position. After 3 min., move the control switch to the "ICE" position, then replace the front panel.
- 2) After 3 min., remove the front panel, then move the control switch to the "OFF" position.
- 3) Remove all ice from the dispenser unit/ice storage bin. **WARNING! If on a dispenser unit, turn off the dispenser unit power supply after dispensing the ice.**

## Cleaning

- 4) Remove the top, left side, and insulation panels, then disconnect the distributor from the distribution hose. Remove the thumbscrew securing cube guide B, then remove cube guide B and cube guide A. See Fig. 14.

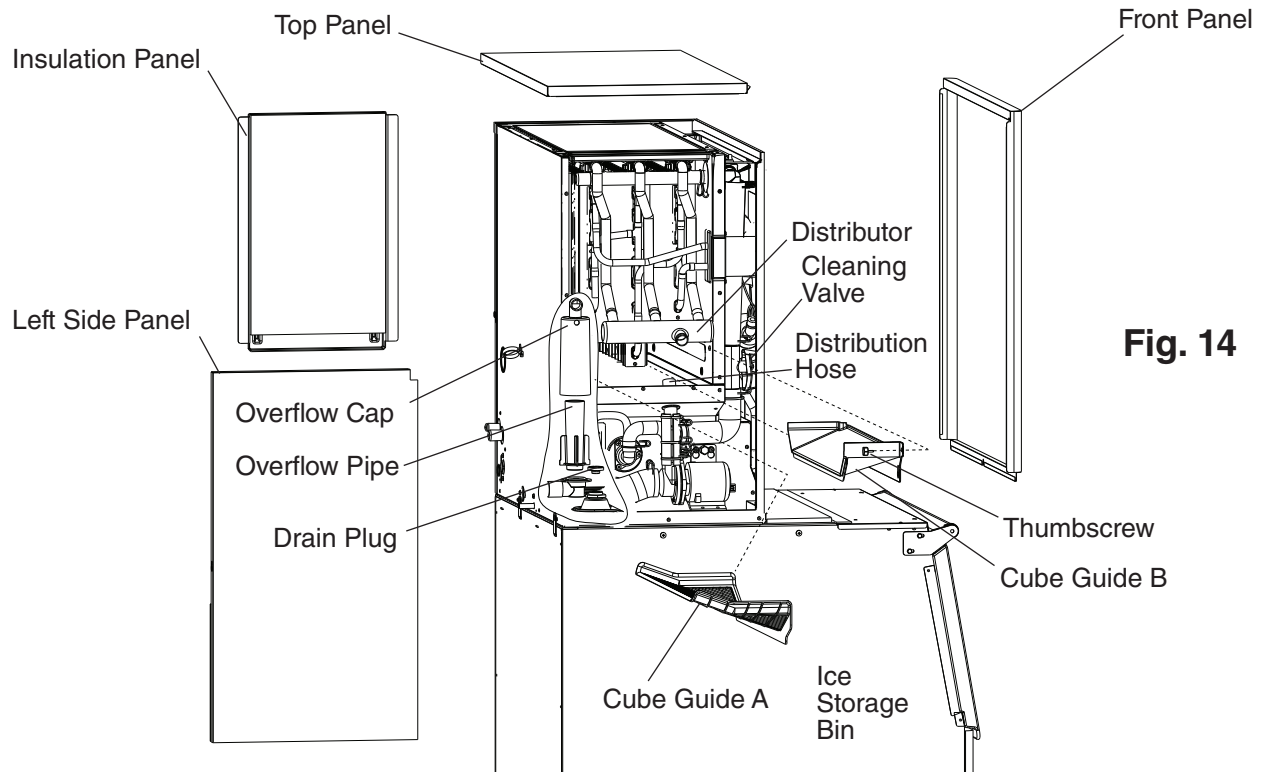

**Fig. 14**

- 5) Remove the overflow cap, overflow pipe, and drain plug. After the water tank has drained, replace the drain plug, overflow pipe, overflow cap, cube guide A, cube guide B, and reconnect the distributor to the distribution hose, then replace the insulation, left side, and top panels.  
**NOTICE! Be careful not to cross thread the drain plug or overflow pipe.**
- 6) To fill the water tank, move the control switch to the "ICE" position, then replace the front panel. After 3 min., remove the front panel, then move the control switch to the "OFF" position.
- 7) Remove the top, left side, and insulation panels, then pour 14 fl. oz. (414 ml) of Hoshizaki "Scale Away" into the water tank. Replace the insulation, left side, and top panels. Turn the cleaning valve to the left until completely vertical (open).
- 8) **NOTICE! To avoid excessive foaming, wait 1 min. before proceeding.**  
After 1 min., move the control switch to the "WASH" position, then replace the front panel.
- 9) After 30 min., remove the front panel, then move the control switch to the "OFF" position.
- 10) Remove the top, left side, and insulation panels, then disconnect the distributor from the distribution hose. Remove the thumbscrew securing cube guide B, then remove cube guide B and cube guide A.

- 11) Remove the overflow cap, overflow pipe, and drain plug. After the water tank has drained, replace the drain plug, overflow pipe, overflow cap, cube guide A, and cube guide B, and reconnect the distributor to the distribution hose, then replace the insulation, left side, and top panels.
- 12) In bad or severe water conditions, turn off the power supply, then remove, clean (cleaning solution = 5 oz. Hoshizaki "Scale Away" per gallon of warm water), rinse, and replace the cube guides, float switch, water supply tubes, spray tubes, and spray guides; turn on the power supply when complete. Otherwise, continue to step 13.

### **Cleaning Rinse**

- 13) Turn the cleaning valve to the right until completely horizontal (closed). Move the control switch to the "ICE" position, then replace the front panel. After 3 min., remove the front panel, then move the control switch to the "OFF" position. Note: The icemaker will not operate unless the cleaning valve is completely closed.
- 14) Turn the cleaning valve to the left until completely vertical (open). Move the control switch to the "WASH" position, then replace the front panel. After 5 min., remove the front panel, then move the control switch to the "OFF" position.
- 15) Remove the top, left side, and insulation panels, then disconnect the distributor from the distribution hose. Remove the thumbscrew securing cube guide B, then remove cube guide B and cube guide A.
- 16) Remove the overflow cap, overflow pipe, and drain plug. After the water tank has drained, replace the drain plug, overflow pipe, overflow cap, cube guide A, and cube guide B, and reconnect the distributor to the distribution hose, then replace the insulation, left side, and top panels.

### **Sanitizing**

- 17) To fill the water tank, turn the cleaning valve to the right until completely horizontal (closed). Move the control switch to the "ICE" position, then replace the front panel. After 3 min., remove the front panel, then move the control switch to the "OFF" position.
- 18) Remove the top, left side, and insulation panels, then pour .78 fl. oz. (23 ml) of an 8.25% sodium hypochlorite solution (chlorine bleach) into the water tank. Replace the insulation, left side, and top panels. Turn the cleaning valve to the left until completely vertical (open). **IMPORTANT! Use regular bleach with no additives. Using a bleach with additives causes excessive foaming during sanitizing, reducing the effectiveness of sanitizing.**
- 19) **NOTICE! To avoid excessive foaming, wait 1 min. before proceeding.** After 1 min., move the control switch to the "WASH" position, then replace the front panel.
- 20) After 45 min., remove the front panel, then move the control switch to the "OFF" position.
- 21) Remove the top, left side, and insulation panels, then disconnect the distributor from the distribution hose. Remove the thumbscrew securing cube guide B, then remove cube guide B and cube guide A.

- 22) Remove the overflow cap, overflow pipe, and drain plug. After the water tank has drained, replace the drain plug, overflow pipe, overflow cap, cube guide A, cube guide B, and reconnect the distributor to the distribution hose, then replace the insulation, left side, and top panels.

### **Sanitizing Rinse 1**

- 23) Turn the cleaning valve to the right until completely horizontal (closed). Move the control switch to the "ICE" position, then replace the front panel. After 3 min., remove the front panel, then move the control switch to the "OFF" position.
- 24) Turn the cleaning valve to the left until completely vertical (open). Move the control switch to the "WASH" position, then replace the front panel. After 5 min., remove the front panel, then move the control switch to the "OFF" position.
- 25) Remove the top, left side, and insulation panels, then disconnect the distributor from the distribution hose. Remove the thumbscrew securing cube guide B, then remove cube guide B and cube guide A.
- 26) Remove the overflow cap, overflow pipe, and drain plug. After the water tank has drained, replace the drain plug, overflow pipe, overflow cap, cube guide A, and cube guide B, and reconnect the distributor to the distribution hose, then replace the insulation, left side, and top panels.

### **Sanitizing Rinse 2**

- 27) Turn the cleaning valve to the right until completely horizontal (closed). Move the control switch to the "ICE" position, then replace the front panel. After 3 min., remove the front panel, then move the control switch to the "OFF" position.
- 28) Turn the cleaning valve to the left until completely vertical (open). Move the control switch to the "WASH" position, then replace the front panel. After 5 min., remove the front panel, then move the control switch to the "OFF" position.
- 29) Remove the top, left side, and insulation panels, then disconnect the distributor from the distribution hose. Remove the thumbscrew securing cube guide B, then remove cube guide B and cube guide A.
- 30) Remove the overflow cap, overflow pipe, and drain plug. After the water tank has drained, replace the drain plug, overflow pipe, overflow cap, cube guide A, and cube guide B, and reconnect the distributor to the distribution hose, then replace the insulation, left side, and top panels.

### **Sanitizing Rinse 3**

- 31) Turn the cleaning valve to the right until completely horizontal (closed). Move the control switch to the "ICE" position, then replace the front panel. After 3 min., remove the front panel, then move the control switch to the "OFF" position.
- 32) Turn the cleaning valve to the left until completely vertical (open). Move the control switch to the "WASH" position, then replace the front panel. After 5 min., remove the front panel, then move the control switch to the "OFF" position.
- 33) Remove the top, left side, and insulation panels, then disconnect the distributor from the distribution hose. Remove the thumbscrew securing cube guide B, then remove cube guide B and cube guide A.

- 34) Remove the overflow cap, overflow pipe, and drain plug. After the water tank has drained, replace the drain plug, overflow pipe, overflow cap, cube guide A, and cube guide B, and reconnect the distributor to the distribution hose, then replace the insulation, left side, and top panels
- 35) Clean the dispenser unit/ice storage bin liner using a neutral cleaner. Rinse thoroughly after cleaning.
- 36) Turn the cleaning valve to the right until completely horizontal (closed). Move the control switch to the "ICE" position. Note: If on a dispenser unit, turn on the dispenser unit power supply.
- 37) Replace all panels in their correct positions.

---

## IV. Preparing the Icemaker for Periods of Non-Use

<b>NOTICE</b>
<ul style="list-style-type: none"><li>• When storing the icemaker for an extended time or in sub-freezing temperatures, follow the instructions below to prevent damage.</li><li>• To prevent damage to the water pump seal, do not leave the control switch in the "WASH" position for extended periods when the water tank is empty.</li></ul>



When the icemaker is not used for two or three days under normal conditions, it is sufficient to move the control switch to the "OFF" position. When storing the icemaker for an extended time or in sub-freezing temperatures, follow the instructions below.

### 1. Remove the water from the icemaker water supply line:

- 1) Turn off the power supply and remove the front panel.
- 2) Close the icemaker water supply line shut-off valve and open the icemaker water supply line drain valve.
- 3) Allow the line to drain by gravity.
- 4) Attach a compressed air or carbon dioxide supply to the icemaker water supply line drain valve.
- 5) Make sure at least 3 minutes have elapsed since you turned off the power supply. Make sure the control switch is in the "ICE" position. Replace the front panel in its correct position and turn on the power supply.
- 6) Blow the icemaker water supply line out using the compressed air or carbon dioxide supply.
- 7) Close the icemaker water supply line drain valve.

### 2. Drain the water tank:

- 1) Turn off the power supply.
- 2) Remove the front, top, and left side panels, then remove the insulation panel.
- 3) Move the control switch to the "OFF" position.
- 4) Disconnect the distributor from the distribution hose. Remove the thumbscrew securing cube guide B. Remove cube guide B, then remove cube guide A. Remove the overflow cap and overflow pipe. See Fig. 14.
- 5) Remove the drain plug. Allow the water tank to drain, then replace the drain plug in its correct position. Be careful not to cross thread it.
- 6) Replace the overflow pipe, overflow cap, cube guide A, cube guide B in their correct positions. Be careful not to cross thread the overflow pipe.
- 7) Reconnect the distributor to the distribution hose.
- 8) Replace the insulation panel, then replace the left side, top, and front panels in their correct positions.
- 9) Remove all ice from the dispenser unit/storage bin. Clean the dispenser unit/storage bin using a neutral cleaner. Rinse thoroughly after cleaning.

---

## **V. Disposal**

The appliance contains refrigerant and must be disposed of in accordance with applicable national, state, and local codes and regulations. Refrigerant must be recovered by properly certified service personnel.

**HOSHIZAKI AMERICA, INC.**

618 Hwy. 74 South, Peachtree City, GA 30269 USA (P) 770.487.2331 (F) 770.487.3360 [hoshizakiamerica.com](http://hoshizakiamerica.com) 1A3757-011