

SRK Condensing Unit (field connected)

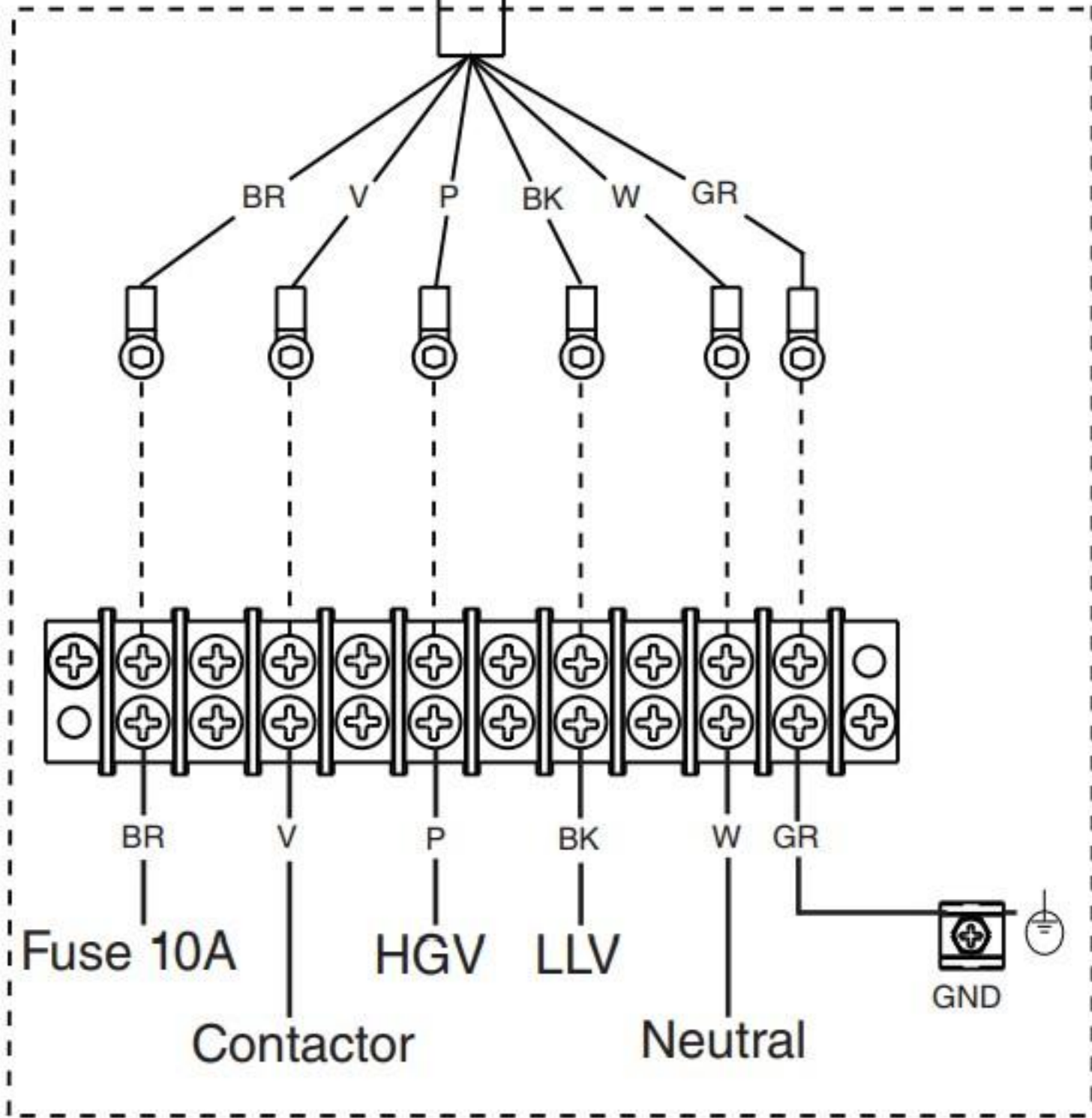

KMS Icemaker Unit (factory connected)

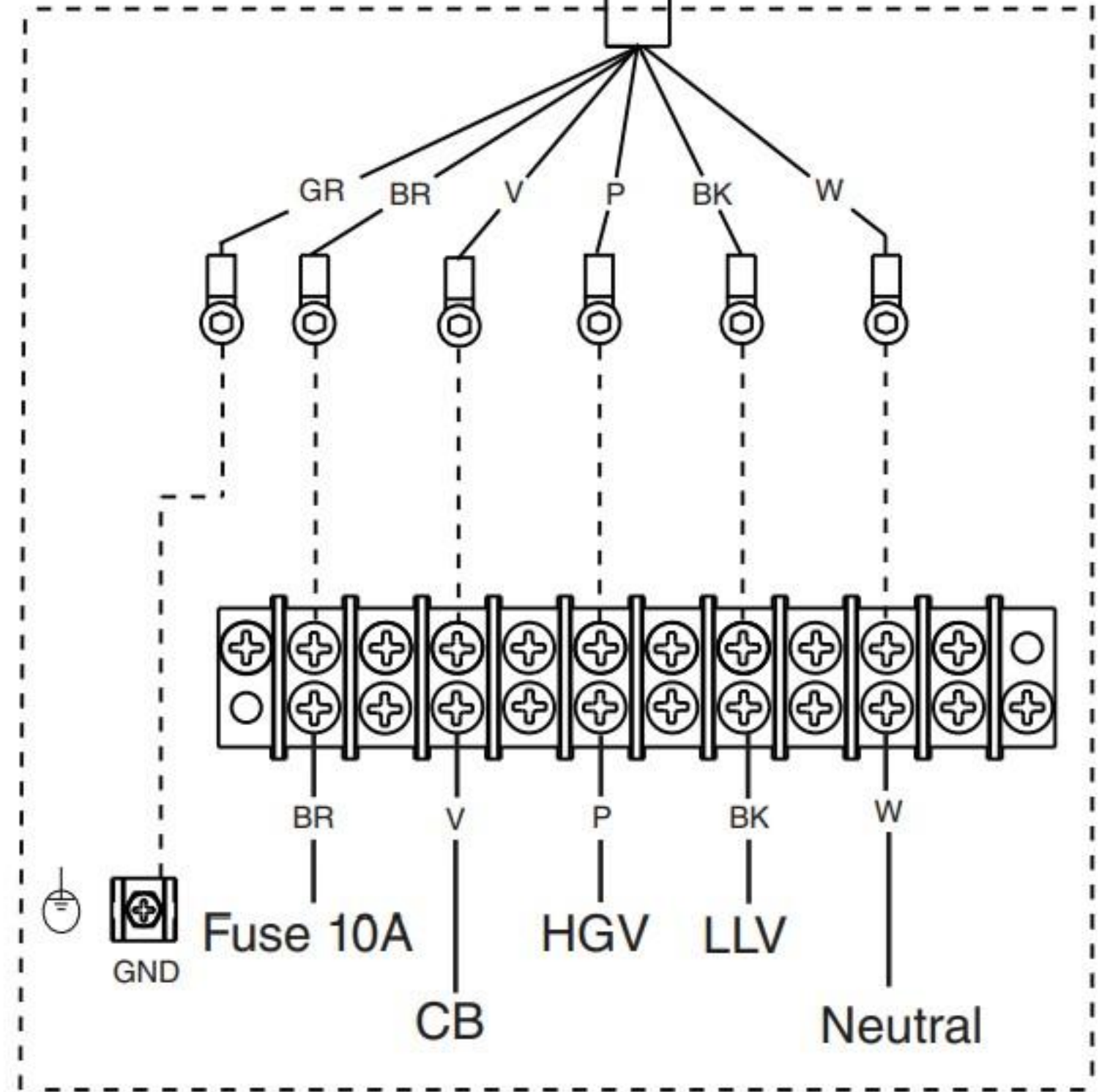

SRK (1 PHASE)

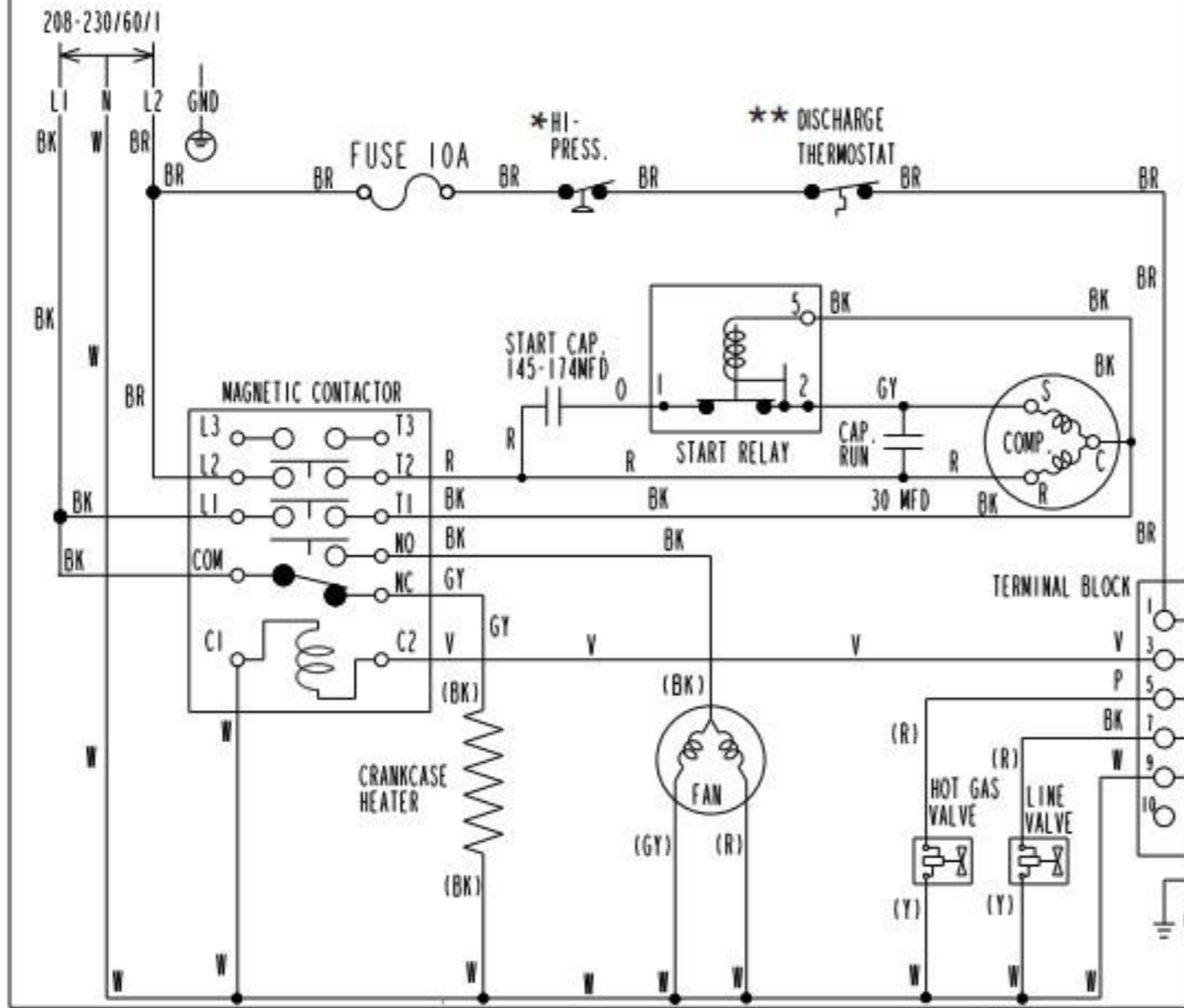

| S4 DIP SWITCH SETTING | NO. 1 | NO. 2 | NO. 3 | NO. 4 | NO. 5 | NO. 6 | NO. 7 | NO. 8 | NO. 9 | NO. 10 |
|-----------------------|-------|-------|-------|-------|-------|-------|-------|-------|-------|--------|
| KMS-822MLJ | OFF | ON | OFF | OFF | OFF | OFF | ON | OFF | OFF | OFF |

| S5 DIP SWITCH SETTING | NO. 1 | NO. 2 | NO. 3 | NO. 4 | NO. 5 |
|-----------------------|-------|-------|-------|-------|-------|
| KMS-822MLJ | OFF | OFF | OFF | OFF | OFF |

X10 - HARVEST PUMP RELAY
 X11 - X10 CONTROL RELAY
 X12 - PUMP OUT RELAY

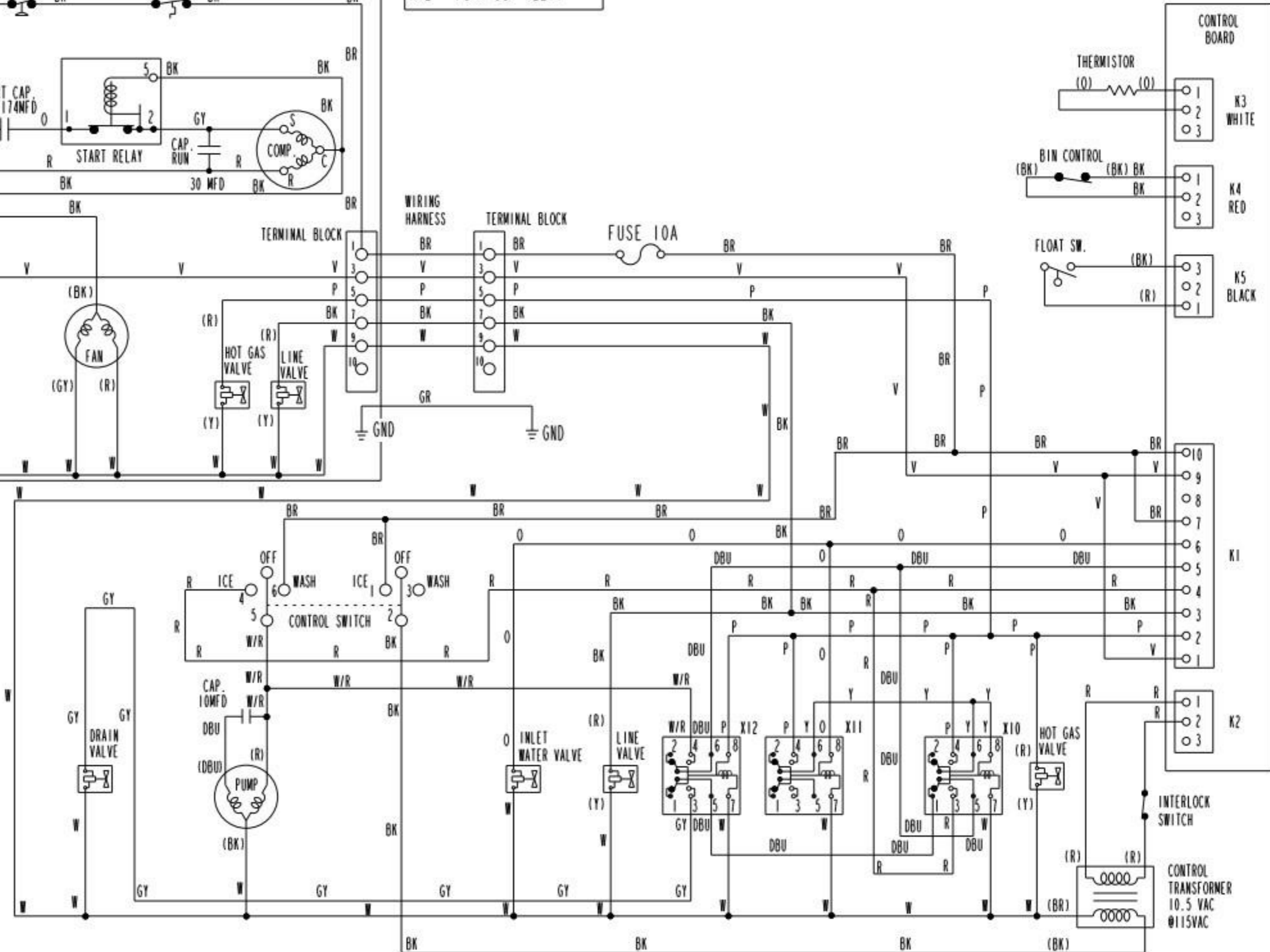

- WIRE COLOR CODE
- BK - BLACK
 - BR - BROWN
 - DBU - DARK BLUE
 - GR - GREEN
 - GY - GRAY
 - O - ORANGE
 - P - PINK
 - R - RED
 - V - VIOLET
 - W - WHITE
 - Y - YELLOW
 - W/BR - WHITE/BROWN
 - W/R - WHITE/RED
 - W/BK - WHITE/BLACK