



# HOSHIZAKI

## Instruction Manual

Modular Crescent Cuber  
Serenity Series

Models  
KMS-2000MLH

Including  
Condensing Unit Models  
SRK-20H/3



[hoshizakiamerica.com](http://hoshizakiamerica.com)

Issued: 4-29-2011  
Revised: 8-15-2017

**⚠ WARNING**

Only qualified service technicians should install and service the icemaker. To obtain the name and phone number of your local Hoshizaki Certified Service Representative, visit [www.hoshizaki.com](http://www.hoshizaki.com). No installation or service should be undertaken until the technician has thoroughly read this Instruction Manual. Likewise, the owner/manager should not proceed to operate the icemaker until the installer has instructed them on its proper operation. Failure to install, operate, and maintain the equipment in accordance with this manual will adversely affect safety, performance, component life, and warranty coverage and may result in costly water damage. Proper installation is the responsibility of the installer. Product failure or property damage due to improper installation is not covered under warranty.

Hoshizaki provides this manual primarily to assist qualified service technicians in the installation, maintenance, and service of the icemaker.

Should the reader have any questions or concerns which have not been satisfactorily addressed, please call, send an e-mail message, or write to the Hoshizaki Technical Support Department for assistance.

Phone: 1-800-233-1940; (770) 487-2331

Fax: 1-800-843-1056; (770) 487-3360

E-mail: [techsupport@hoshizaki.com](mailto:techsupport@hoshizaki.com)

**HOSHIZAKI AMERICA, INC.**

618 Highway 74 South

Peachtree City, GA 30269

Attn: Hoshizaki Technical Support Department

**NOTE:** To expedite assistance, all correspondence/communication **MUST** include the following information:

- Model Number \_\_\_\_\_
- Serial Number \_\_\_\_\_
- Complete and detailed explanation of the problem.

## **IMPORTANT**

This manual should be read carefully before the icemaker is installed and operated. Read the warnings and guidelines contained in this booklet carefully as they provide essential information for the continued safe use and maintenance of the icemaker. Retain this booklet for any further reference that may be necessary.

## **CONTENTS**

Important Safety Information .....	4
I. Specifications.....	6
A. Electrical and Refrigerant Data .....	6
1. KMS-2000MLH.....	6
2. SRK-20H .....	7
3. SRK-20H3 .....	8
B. Dimensions/Connections .....	9
1. KMS-2000MLH.....	9
2. SRK-20H/3 .....	10
II. Installation and Operating Instructions .....	11
A. Location .....	11
1. Icemaker .....	11
2. Remote Condensing Unit.....	12
B. Checks Before Installation.....	13
1. Icemaker .....	13
2. Remote Condensing Unit.....	13
C. How to Remove Panels.....	14
1. Icemaker .....	14
2. Remote Condensing Unit.....	14
D. Installation of the Icemaker .....	15
1. Setup.....	15
2. Water Tank Removal.....	17
E. Installation of the Remote Condensing Unit.....	21
1. Setup.....	21
2. Line Set .....	21
3. Line Set Installation .....	22
F. Electrical Connection .....	24
G. Water Supply and Drain Connections .....	27
H. Final Checklist.....	29
I. Startup.....	30
III. Cleaning and Maintenance .....	32
A. Cleaning and Sanitizing Instructions.....	32
1. Cleaning Procedure.....	33
2. Sanitizing Procedure - Following Cleaning Procedure .....	34
B. Maintenance.....	35
C. Preparing the Icemaker for Periods of Non-Use.....	36

---

## Important Safety Information

Throughout this manual, notices appear to bring your attention to situations which could result in death, serious injury, damage to the unit, or damage to property.

**⚠ WARNING** Indicates a hazardous situation which could result in death or serious injury.

**NOTICE** Indicates a situation which could result in damage to the unit or property.

**IMPORTANT** Indicates important information about the installation, use, and care of the unit.

### **⚠ WARNING**

This icemaker should be destined only to the use for which it has been expressly conceived. Any other use should be considered improper and therefore dangerous. The manufacturer cannot be held responsible for injury or damage resulting from improper, incorrect, and unreasonable use. Failure to install, operate, and maintain the equipment in accordance with this manual will adversely affect safety, performance, component life, and warranty coverage and may result in costly water damage.

**To reduce the risk of death, electric shock, serious injury, or fire, follow basic precautions including the following:**

- Only qualified service technicians should install and service the icemaker.
- Move the control switch to the "OFF" position and turn off the power supply to the remote condensing unit before servicing. Place the icemaker disconnect (if applicable) in the "OFF" position. Lockout/Tagout to prevent the power supply from being turned back on inadvertently.
- This icemaker must be installed in accordance with applicable national, state, and local codes and regulations.
- To reduce the risk of electric shock, do not touch the control switch or service switch with damp hands.
- Do not make any alterations to the unit. Alterations could result in electric shock, injury, fire, or damage to the unit.
- This appliance is not intended for use by persons (including children) with reduced physical, sensory, or mental capabilities, or lack of experience and knowledge, unless they have been given supervision or instruction concerning use of the appliance by a person responsible for their safety.
- Young children should be properly supervised around this appliance.
- Do not climb, stand, or hang on the icemaker or allow children or animals to do so. Serious injury could occur or the icemaker could be damaged.
- Do not use combustible spray or place volatile or flammable substances near the unit. They might catch fire.
- Keep the area around the unit clean. Dirt, dust, or insects in the unit could cause harm to individuals or damage to the equipment.

## **⚠ WARNING, continued**

### **Icemaker**

- Do not connect the icemaker to an external power source. Icemaker power supply and ground connection are supplied from the remote condensing unit via the wire bundle provided with the remote condensing unit.
- Wire bundle routing (conduit) and disconnect (if required) must meet national, state, and local electrical code requirements. Failure to meet these code requirements could result in death, electric shock, serious injury, fire, or damage.
- **THE ICEMAKER MUST BE GROUNDED.** Failure to properly ground the icemaker could result in death or serious injury.

### **Remote Condensing Unit**

- Remote condensing unit electrical connection must be hard-wired and must meet national, state, and local electrical code requirements. Failure to meet these code requirements could result in death, electric shock, serious injury, fire, or damage.
- The remote condensing unit requires an independent power supply of proper capacity. See the nameplate for electrical specifications. Failure to use an independent power supply of proper capacity can result in a tripped breaker, blown fuse, damage to existing wiring, or component failure. This could lead to heat generation or fire.
- **THE REMOTE CONDENSING UNIT MUST BE GROUNDED.** Failure to properly ground the remote condensing unit could result in death or serious injury.

## ***NOTICE***

- Follow the water supply, drain connection, and maintenance instructions carefully to reduce the risk of costly water damage.
- In areas where water damage is a concern, install in a contained area with a floor drain.
- Install the icemaker in a location that stays above freezing. Normal operating ambient temperature must be within 45°F to 100°F (7°C to 38°C).
- Do not leave the icemaker on during extended periods of non-use, extended absences, or in sub-freezing temperatures. To properly prepare the icemaker for these occasions, follow the instructions in "III.C. Preparing the Icemaker for Periods of Non-Use."
- Do not place objects on top of the appliance.
- The dispenser unit/ice storage bin is for ice use only. Do not store anything else in the dispenser unit/ice storage bin.

# I. Specifications

## A. Electrical and Refrigerant Data

### 1. KMS-2000MLH

<b>HOSHIZAKI ICE MAKER</b>	
MODEL NUMBER	KMS-2000MLH
SERIAL NUMBER	
AC SUPPLY VOLTAGE	115-120/60/1
PUMP	120V 1.2FLA 60W
OTHER	115V 0.8A
DESIGN PRESSURE	HI-467PSI LO-230PSI
TOTAL REFRIGERANT CHARGE WITH HOSHIZAKI CONDENSING UNIT SRK-20H/3	404A 27 LB. 5 OZ.

**NOT INTENDED FOR OUTDOOR USE!**  
**WARNING!** Power supplied from remote condensing unit.  
To reduce the risk of death, electric shock, serious injury, or  
fire, turn off the remote condensing unit power supply before  
servicing. Lockout/Tagout to prevent the power supply from  
being turned back on inadvertently.

**Hoshizaki America, Inc.**  
Peachtree City, GA  
[www.hoshizaki.com](http://www.hoshizaki.com)

For certification marks, see the nameplate  
on the rear panel.

The rating label and nameplate provide electrical and refrigerant data. The rating label can be seen by removing the front panel. The nameplate is located on the rear panel.

<b><i>IMPORTANT</i></b>
<b>This icemaker is designed for connection to Hoshizaki Remote Condensing Unit Model SRK-20H/3 only! CONNECTION TO ANOTHER REMOTE CONDENSING UNIT WILL VOID WARRANTY.</b>

We reserve the right to make changes in specifications and design without prior notice.

## 2. SRK-20H

### HOSHIZAKI CONDENSING UNIT

MODEL NUMBER	SRK-20H
SERIAL NUMBER	
AC SUPPLY VOLTAGE	208-230/60/1 (3 WIRE WITH NEUTRAL FOR 115V)
COMPRESSOR	230V 17.5RLA 121LRA
FAN	115V 2.6FLA (total) 126W
OTHER	115V 1.2A
MAXIMUM FUSE SIZE	30 AMPS
MAX. HACR BREAKER (USA ONLY)	30 AMPS
MAX. CIRC. BREAKER (CANADA ONLY)	30 AMPS
MINIMUM CIRCUIT AMPACITY	30 AMPS
DESIGN PRESSURE	HI-467PSI LO-230PSI
REFRIGERANT	404A 27 LB. 5 OZ.

**MOTOR-COMPRESSOR THERMALLY PROTECTED  
FOR OUTDOOR USE**

**Hoshizaki America, Inc.**  
Peachtree City, GA  
[www.hoshizaki.com](http://www.hoshizaki.com)

**For certification marks, see the nameplate  
on the condensing unit.**

The nameplate provides electrical and refrigerant data. The nameplate is located on the remote condensing unit.

We reserve the right to make changes in specifications and design without prior notice.

### 3. SRK-20H3

## HOSHIZAKI CONDENSING UNIT

MODEL NUMBER	SRK-20H3
SERIAL NUMBER	
AC SUPPLY VOLTAGE	208-230/60/3
COMPRESSOR	230V 11.0RLA 105LRA
FAN	115V 2.6FLA (total) 126W
OTHER	115V 1.2A
MAXIMUM FUSE SIZE	20 AMPS
MAX. HACR BREAKER (USA ONLY)	20 AMPS
MAX. CIRC. BREAKER (CANADA ONLY)	20 AMPS
MINIMUM CIRCUIT AMPACITY	20 AMPS
DESIGN PRESSURE	HI-467PSI LO-230PSI
REFRIGERANT	404A 27 LB. 5 OZ.

**MOTOR-COMPRESSOR THERMALLY PROTECTED  
FOR OUTDOOR USE**

**Hoshizaki America, Inc.**  
Peachtree City, GA  
[www.hoshizaki.com](http://www.hoshizaki.com)

**For certification marks, see the nameplate  
on the condensing unit.**

The nameplate provides electrical and refrigerant data. The nameplate is located on the remote condensing unit.

We reserve the right to make changes in specifications and design without prior notice.

# B. Dimensions/Connections

## 1. KMS-2000MLH

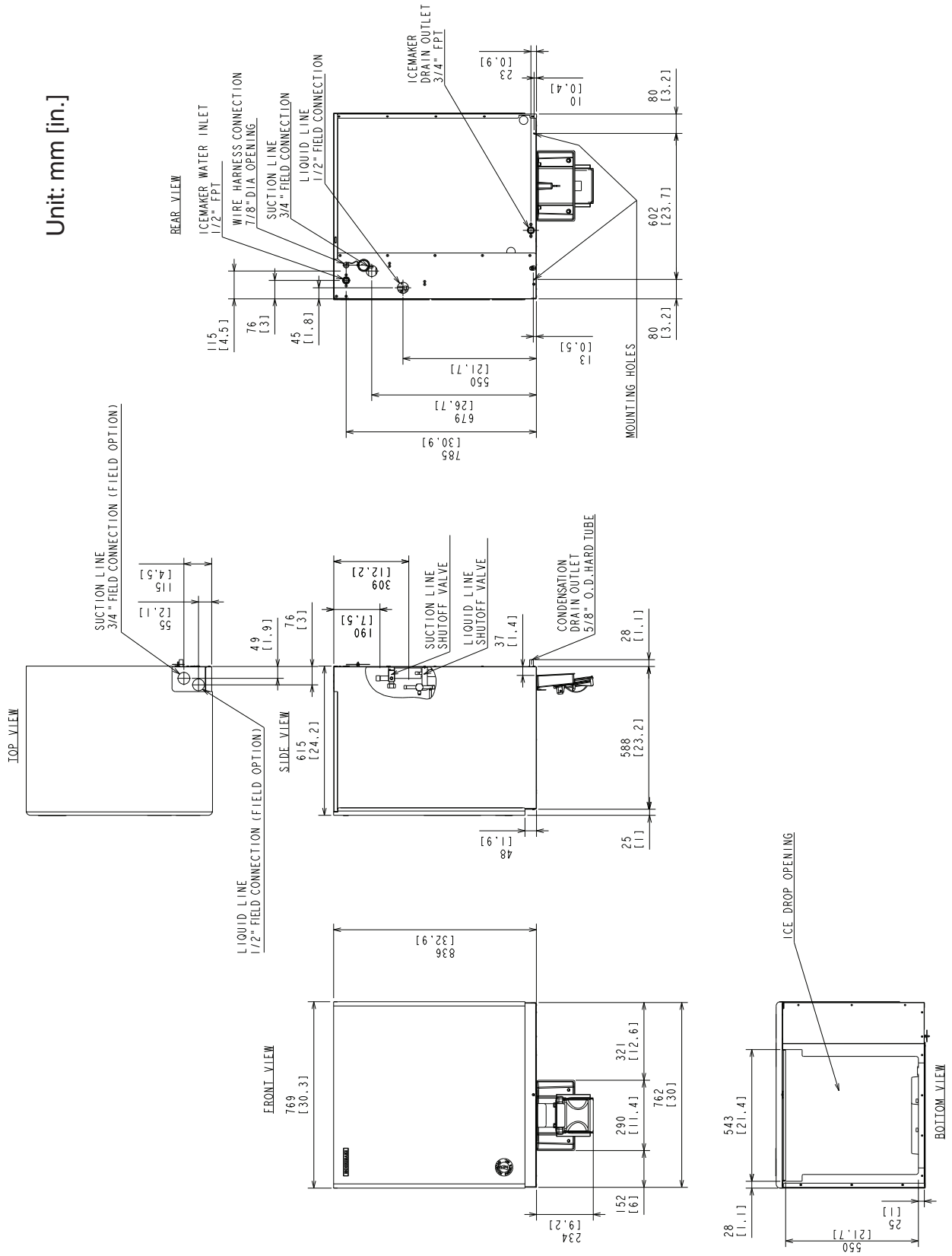

## 2. SRK-20H/3

Unit: mm [in.]

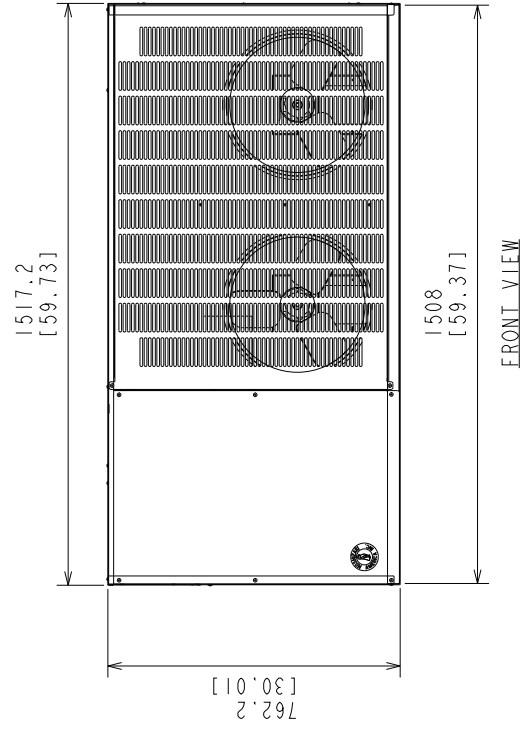
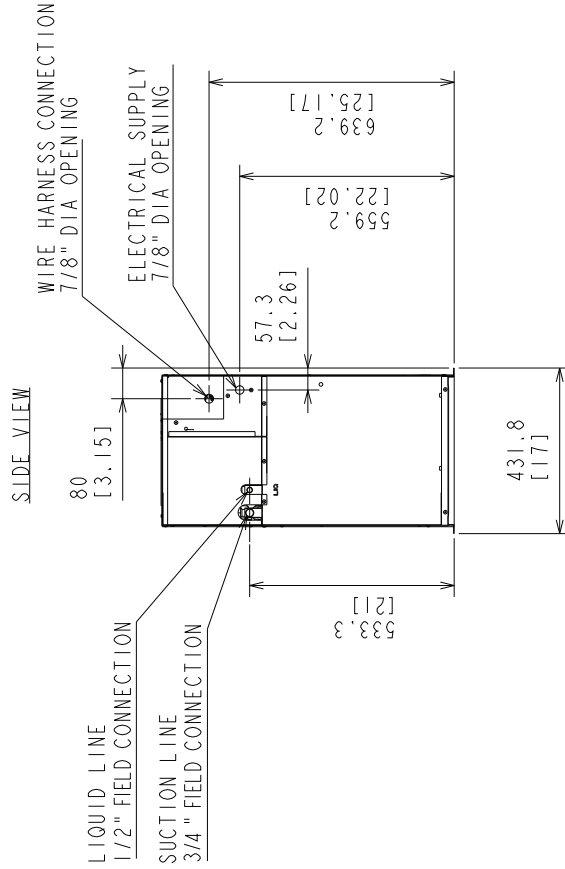
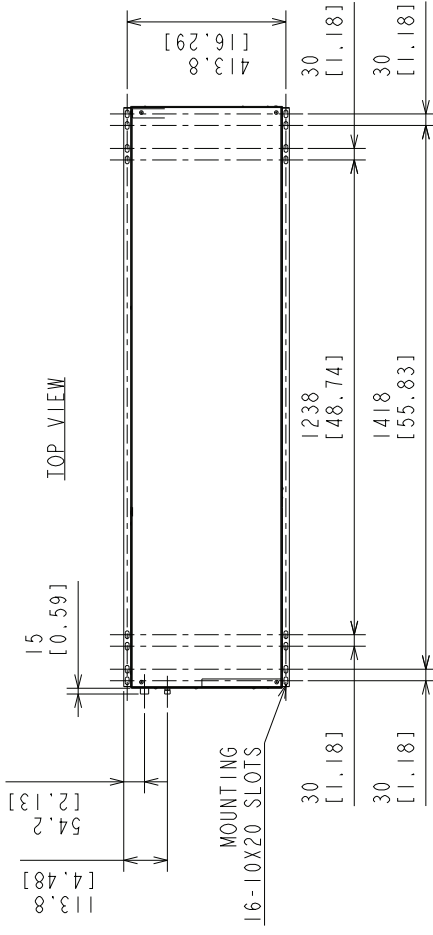

Note: Legs are included with remote condensing unit.  
Leg height is 380 mm (14.96 in.).

---

## II. Installation and Operating Instructions

### **⚠ WARNING**

- The icemaker and remote condensing unit must be installed in accordance with applicable national, state, and local codes and regulations.
- Failure to install, operate, and maintain the equipment in accordance with this manual will adversely affect safety, performance, component life, and warranty coverage and may result in costly water damage.
- **CHOKING HAZARD:** Ensure all components, fasteners, and thumbscrews are securely in place after installation. Make sure that none have fallen into the dispenser unit/storage bin.

## A. Location

### 1. Icemaker

#### **NOTICE**

- This icemaker is not intended for outdoor use. Normal operating ambient temperature must be within 45°F to 100°F (7°C to 38°C); Normal operating water temperature must be within 45°F to 90°F (7°C to 32°C). Operation of the icemaker, for extended periods, outside of these normal temperature ranges may affect icemaker performance.
- This icemaker will not work at sub-freezing temperatures. To prevent damage to the water supply line, drain the icemaker if the air temperature is going to go below 32°F (0°C). See "III.C. Preparing the Icemaker for Periods of Non-Use."

- The icemaker should not be located next to ovens, grills, or other high heat producing equipment.
- Allow 6" (15 cm) clearance at rear and sides for proper air circulation and ease of maintenance and/or service should they be required.
- The location must provide a firm and level foundation for the equipment.

## 2. Remote Condensing Unit

### NOTICE

The remote condensing unit is intended for outdoor use. Normal operating ambient temperature must be within -20°F to 122°F (-29°C to 50°C). Operation of the remote condensing unit, for extended periods, outside of this normal temperature range may affect icemaker performance.

The icemaker must be coupled with the appropriate remote condensing unit as listed below.

Hoshizaki Icemaker	Hoshizaki Remote Condensing Unit
KMS-2000MLH	SRK-20H/3

### NOTICE

Failure to install the equipment within these guidelines may adversely affect performance, component life, and warranty coverage.

The remote condensing unit must be positioned in a permanent site under the following guidelines:

- A firm and flat site.
- A dry and well ventilated area with 24" (61 cm) clearance in both front and rear for proper air circulation and ease of maintenance and/or service should they be required. See Fig. 1.
- The maximum line set length is 66 feet.
- The maximum vertical distance between the remote condensing unit and icemaker is 33 feet above or 10 feet below the icemaker. These distances are measured fitting to fitting. See Fig. 2.
- If the vertical distance between the remote condensing unit and the icemaker is greater than 20 feet (not to exceed 33 feet), an "S" oil-trap (3/4" OD copper tubing) must be installed in the suction line. This ensures sufficient oil return to the compressor.

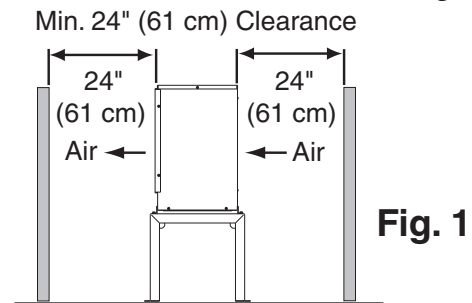

Fig. 1

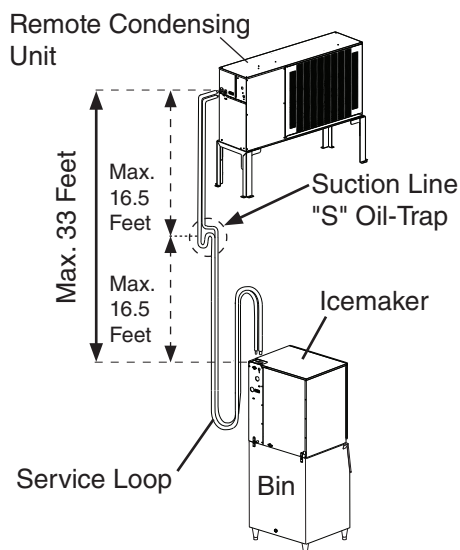
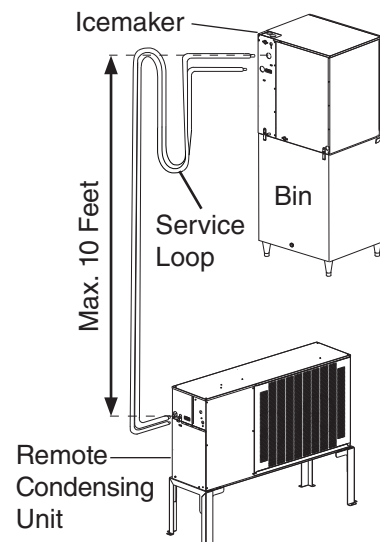

Fig. 2



## B. Checks Before Installation

- Visually inspect the exterior of the shipping containers and immediately report any damage to the carrier. Upon opening the containers, any concealed damage should also be immediately reported to the carrier.
- Remove the shipping carton, tape, and packing material. If any are left in the icemaker or remote condensing unit, they will not work properly.

### 1. Icemaker

- Remove the panels to prevent damage when installing the icemaker. See "II.C. How to Remove Panels." **NOTICE! Leave the front frame in place until "II.D.2 Water Tank Removal."**
- Remove the package containing the accessories.
- Remove the protective plastic film from the panels. If the icemaker is exposed to the sun or to heat, remove the film after the icemaker cools.
- Check that the refrigerant lines do not rub or touch lines or other surfaces.
- This icemaker can be installed on a dispenser unit or storage bin 30" wide or wider. For options, contact your local Hoshizaki distributor.
- **This icemaker is designed for connection to Hoshizaki Remote Condensing Unit Model SRK-20H/3 only! CONNECTION TO ANOTHER REMOTE CONDENSING UNIT WILL VOID WARRANTY.**

### 2. Remote Condensing Unit

- See the nameplate on the remote condensing unit. Check that your voltage supplied corresponds with the voltage specified on the nameplate.
- Remove the panels to prevent damage when installing the remote condensing unit. See "II.C. How to Remove Panels."
- Remove the package containing the accessories.
- Check that the refrigerant lines do not rub or touch lines or other surfaces, and that the fan blades turn freely.
- Check that the compressor is snug on all mounting pads.

## C. How to Remove Panels

### 1. Icemaker

- Front Panel: Remove the screw. Lift up and towards you.
- Top Panel: Lift off.
- Right Side Panel: Remove the screw. Slide forward slightly and lift off.
- Insulation Panel: Remove the thumbscrews. Lift up slightly and pull towards you.
- Top Insulation: Lift off.
- Front Frame: **NOTICE! Leave the front frame in place until "II.D.2 Water Tank Removal."**

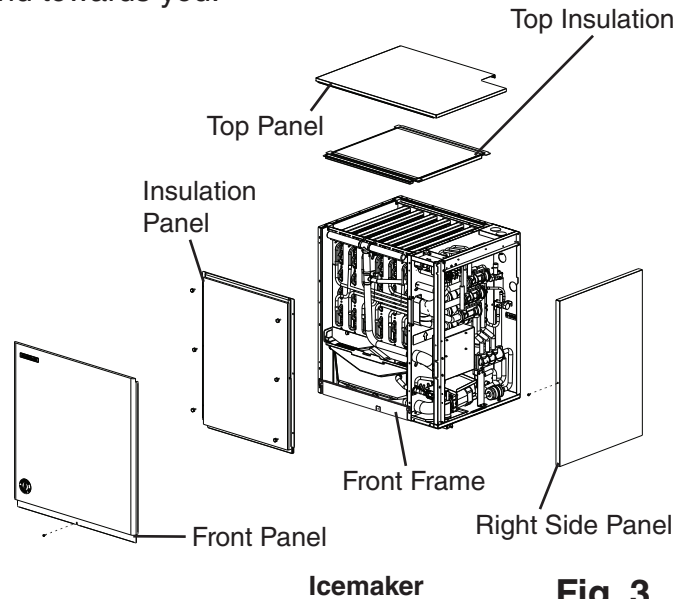

Fig. 3

### 2. Remote Condensing Unit

- Top Panel: Remove the screws and lift off.
- Front Panel: Remove the screws and lift off.
- Left Side/Lower Panel (L1): Remove the screws and lift off.
- Left Side/Upper Panel Left (L2): Remove the screws and lift off.
- Left Side/Upper Panel Right (L3): Remove the screws and lift off.
- Louver Panel: Remove the screws and lift off.
- Right Side Panel: Remove the screws and lift off.

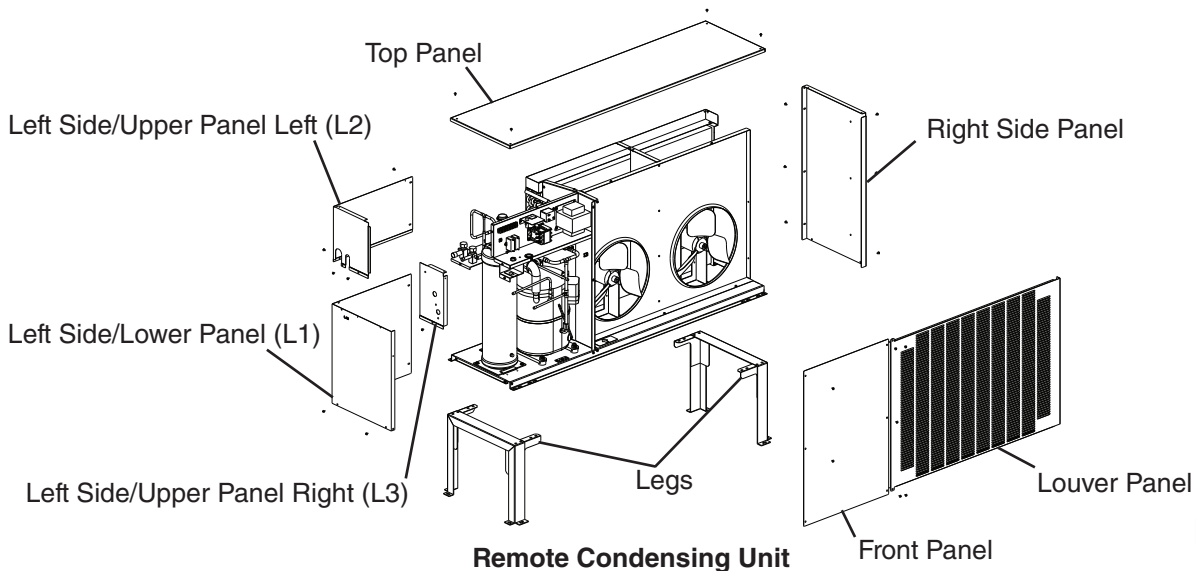

Fig. 4

## D. Installation of the Icemaker

### NOTICE

- Do not connect the icemaker to an external power source. Icemaker power supply and ground connection are supplied from the remote condensing unit via the wire bundle provided with the remote condensing unit. For details, see "II.F. Electrical Connection."
- Before operating the icemaker, the bin control must be installed correctly. Failure to properly install the bin control could result in ice backup and unit damage.
- Failure to properly seal the icemaker to the dispenser unit/storage bin could result in water leakage and costly water damage.

### 1. Setup

- 1) If mounting the icemaker on top of a dispenser unit, follow the dispenser unit's setup procedure. If mounting the icemaker on top of a storage bin, unpack the storage bin and attach the 4 adjustable legs provided (bin accessory) to the bottom of the storage bin.
- 2) Position the dispenser unit/storage bin in its permanent location.
- 2a) **Dispenser Unit:** Install the dispenser unit adapter kit. Make sure the dispenser unit adapter kit opening and the icemaker water tank opening match. If not, cut the dispenser unit adapter kit to the dimensions needed to match the icemaker water tank opening. **NOTICE! The dispenser unit adapter kit opening MUST match the icemaker water tank opening. A smaller opening may result in water leaking. Seal the adapter kit to the dispenser unit with RTV-748 sealant (provided) or equivalent.** See Fig. 5.

### Dispenser Unit Application

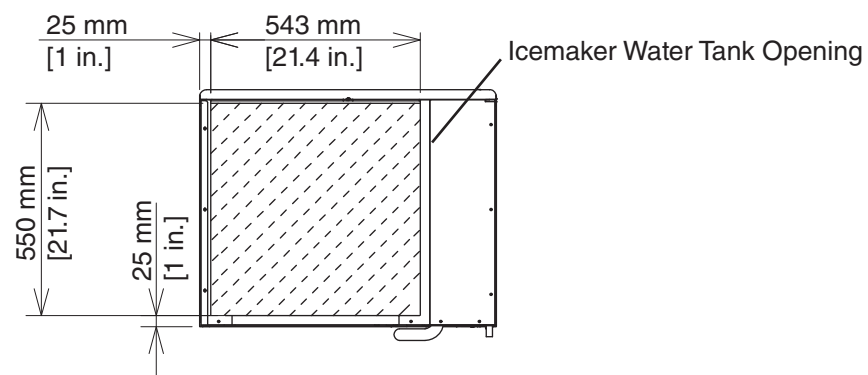
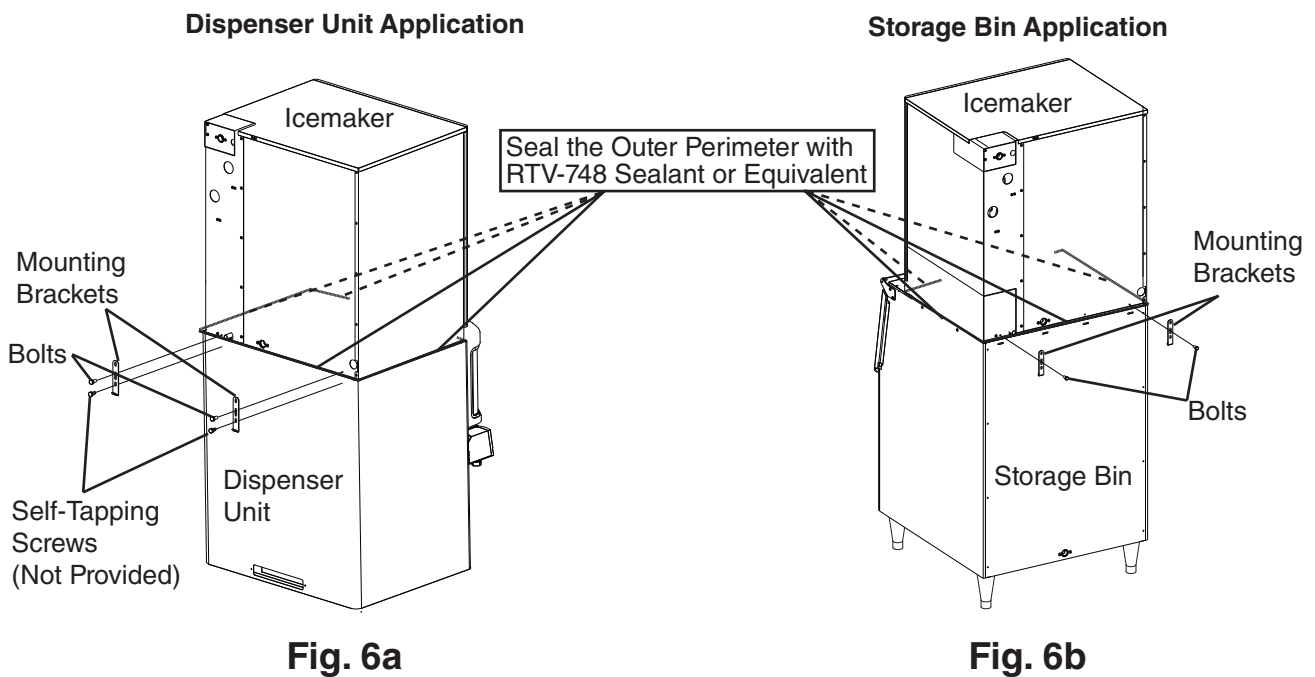

Fig. 5

- 2b) **Storage Bin:** If required, install a top kit, a storage bin extension bracket HS kit, or a brace HS kit. Contact your local Hoshizaki distributor for recommendations.
- 3) Place the icemaker on top of the dispenser unit/storage bin.

- 4a) **Dispenser Unit:** Follow the dispenser unit's instructions for securing the icemaker to the dispenser unit. If no instructions are available, secure the icemaker to the dispenser unit using the mounting brackets provided. Rotate the mounting brackets so that they fit flush to the dispensing unit. See Fig. 6a. Secure the mounting brackets to the icemaker with the bolts provided. Secure the mounting brackets to the dispensing unit with self-tapping screws (not provided). **NOTICE! Use care to avoid damage to the dispenser unit components when attaching the mounting brackets.** Seal the outer perimeter of the icemaker to the dispenser unit with RTV-748 sealant (provided) or equivalent.
- 4b) **Storage Bin:** Secure the icemaker to the storage bin using the 2 mounting brackets and the bolts provided. See Fig. 6b. Seal the outer perimeter of the icemaker to the storage bin with RTV-748 sealant (provided) or equivalent.
- 5) Level the icemaker and dispensing unit/storage bin in both the left-to-right and front-to-rear directions. If using a storage bin, adjust the storage bin legs to make the icemaker level.



## 2. Water Tank Removal

- 1) Remove the front frame and splash curtain. See Fig. 7.
- 2) Disconnect the pump suction hose, drain pipe, and float connection hose at the evaporator case wall. Disconnect the water tank drain hose from the bottom of the water tank. Although the water tank can be removed at this point, do not remove it yet because the bin control is taped inside the water tank.

### NOTICE

The bin control cable is routed through the back of the icemaker. If care is not taken when removing the water tank, the bin control cable could be severed.

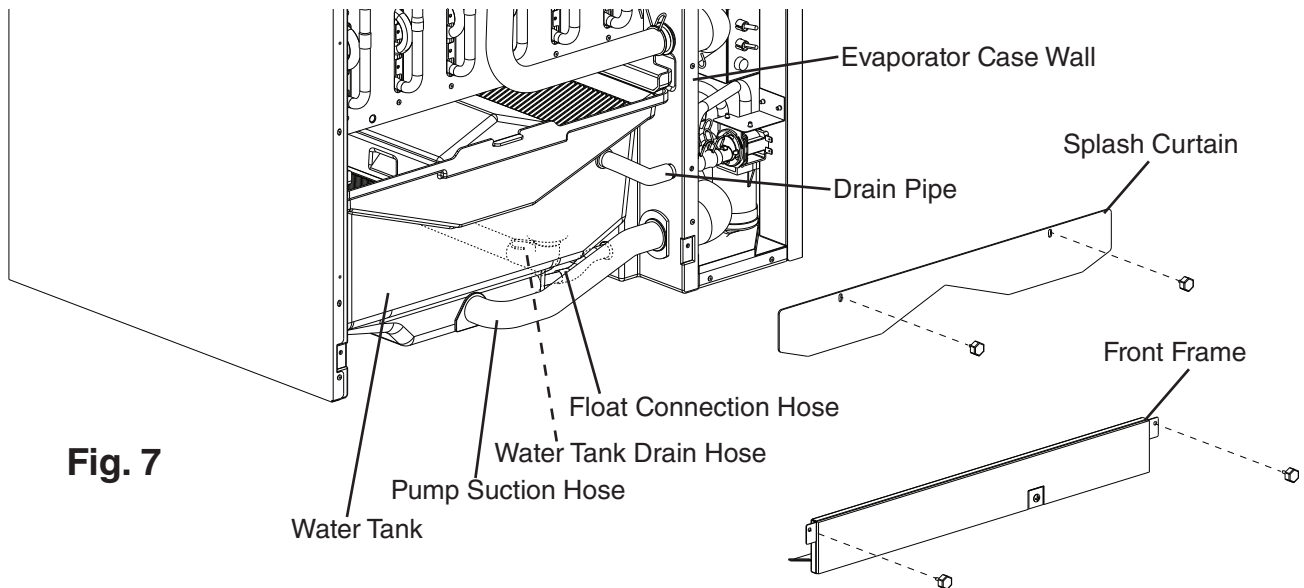

Fig. 7

- 3) Pull out the water tank only as far as shown in Fig. 8.
- 4) Remove the cube guide, then remove the bin control assembly.
- 5) **Being careful not to pull the bin control cable**, remove the water tank completely from the icemaker.
- 6) Remove the remaining pieces of tape from the water tank and leave the water tank out of the icemaker for now.

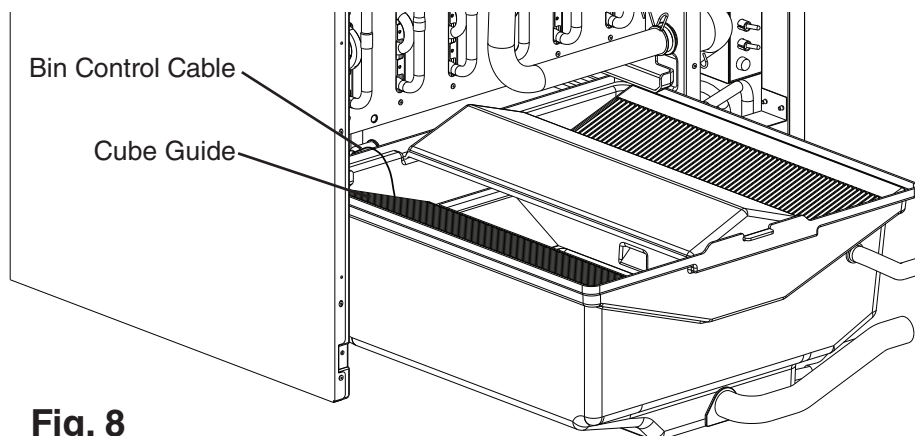

Fig. 8

- 7) Dispenser Unit: Seal the inner perimeter of the icemaker evaporator section to the dispenser unit adapter kit with RTV-748 sealant (provided) or equivalent. See Fig. 9. Make sure the inner perimeter sealant meets the outer perimeter sealant and that there are no gaps.

**⚠ WARNING**

The following locations must be properly sealed with RTV-748 sealant or equivalent. Otherwise, water leakage may occur which could result in a slip hazard and costly water damage.

- Contact points between the dispenser unit and the dispenser unit adapter kit.
- Contact points between the icemaker evaporator section and the dispenser unit adapter kit.
- Outer perimeter contact points between the dispenser unit and icemaker.

Seal the Inner Perimeter with RTV-748 Sealant or Equivalent. Make sure the inner perimeter sealant meets the outer perimeter sealant and that there are no gaps.

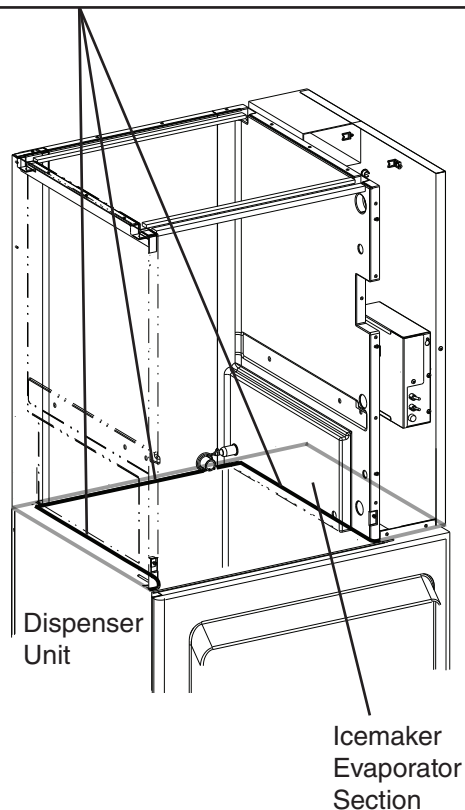

**Fig. 9**

### 3. Bin Control

#### **NOTICE**

Before operating the icemaker, the bin control assembly must be installed correctly. Failure to properly install the bin control assembly could result in ice backup and unit damage.

- 1) Remove the 2 outer switch cover thumbscrews from the switch cover. See Fig. 10.
- 2) Remove the 2 inner switch cover thumbscrews. Slide the bin control out of the switch mount.
- 3) Mount the bin control to the extension bracket (accessory bag) using the 2 thumbscrews from the accessory bag. Route the bin control cable from the outer corner of the bin control up through the gap in the extension bracket.
- 4) Using the 2 thumbscrews removed in step 2, mount the extension bracket to the switch cover.
- 5) Replace the outer switch cover thumbscrews into the slots on the switch bracket. Do not tighten.

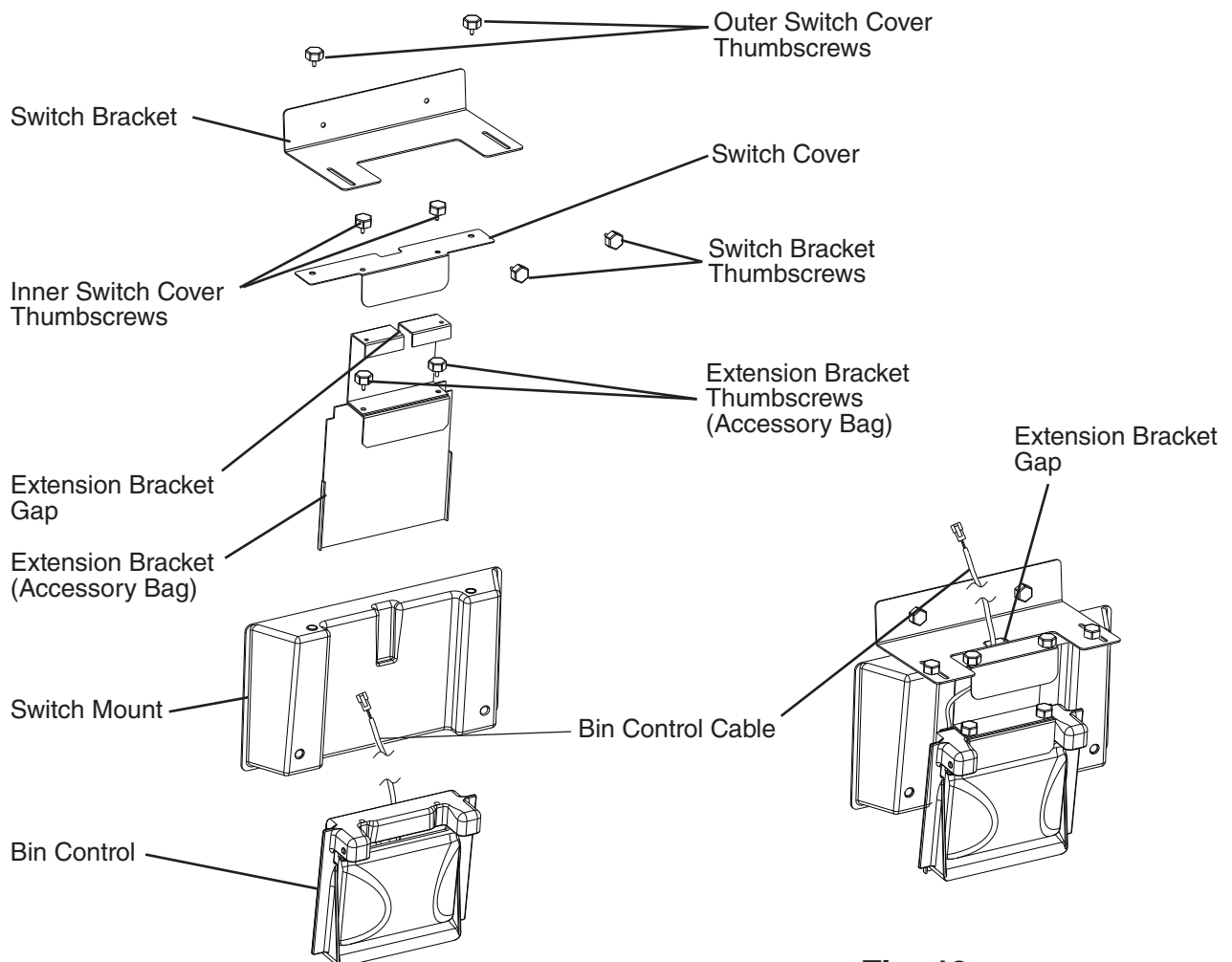
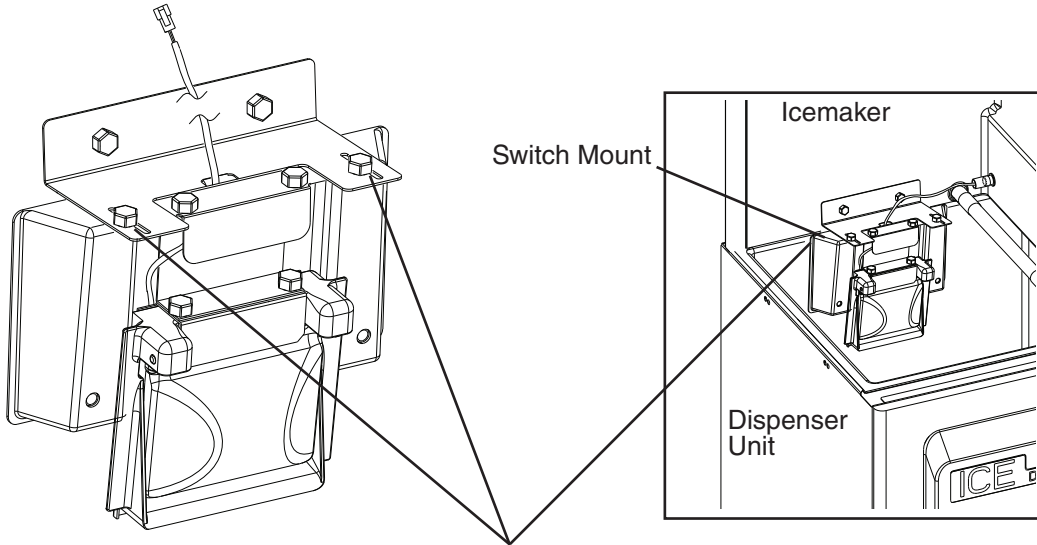

**Fig. 10**

- 6) Slide the bin control assembly all the way back until the switch mount is flush with the dispenser unit bin wall or the storage bin wall, top kit extension bracket, or brace. See Fig. 11. Tighten the outer switch cover thumbscrews.

**NOTICE**

On dispenser unit applications, do not leave a gap between the bin control and the wall of the dispenser unit bin wall. If a gap is left between the bin control and the wall of the dispenser unit bin wall, ice may get between them and damage the bin control.



**Dispenser Unit:** Slide the bin control assembly all the way back until the switch mount is flush with the dispenser unit bin wall.

**Storage Bin:** Slide the bin control assembly all the way back until the switch mount is flush with the storage bin wall, extension bracket, or brace.

**Fig. 11**

- 7) Pull the bin control cable so that there is no slack in the ice drop area, then secure the hose that the lead runs through with a cable tie. See Fig. 12.

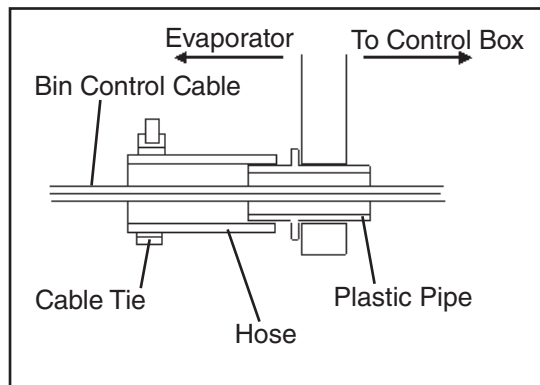

**Fig. 12**

- 8) Replace the water tank in the icemaker and reconnect the 4 hoses.  
 Note: Panels replaced during "I.I. Startup."

## E. Installation of the Remote Condensing Unit

### ⚠ WARNING

- Installation must be performed by properly trained and EPA-certified service personnel.
- Power supply and ground wire to the icemaker are supplied from the remote condensing unit. For details, see "II.F. Electrical Connection."

### 1. Setup

- 1) Secure the legs to the remote condensing unit with the 16 bolts and nuts provided. See Fig. 13.
- 2) The legs have 8 mounting holes. Secure the legs with 8 bolts (not included).

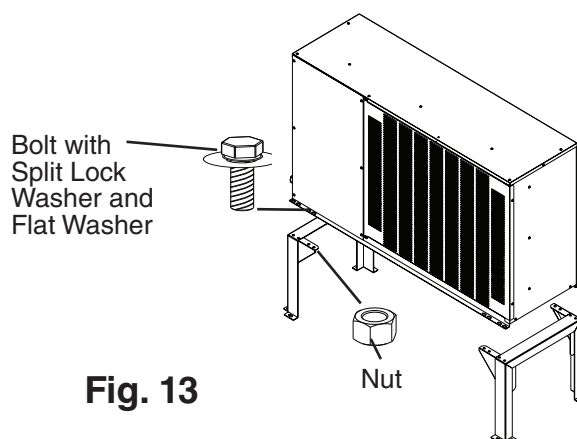

Fig. 13

### 2. Line Set

### NOTICE

The icemaker, remote condensing unit, and line set must contain the same type of refrigerant. Mixing of refrigerants will result in improper operation and possible damage to equipment.

- The maximum line set length is 66 feet and no refrigerant charge adjustment is necessary. **NOTICE! Do not exceed maximum line set length.**

Line Set Size and Length for SRK-20H(3) Remote Condensing Units				
Model	Liquid Line	Suction Line	Factory Line Set Lengths (ft)	Maximum Line Set Length (ft)
KMS-2000MLH	1/2" OD	3/4" OD	25, 35, and 55	66

- The maximum vertical distance between the remote condensing unit and icemaker is 33 feet above or 10 feet below the icemaker. These distances are measured fitting to fitting. See Fig. 14. **NOTICE! Do not exceed maximum vertical distance.**
- If the vertical distance between the remote condensing unit and the icemaker is greater than 20 feet (not to exceed 33 feet), an "S" oil-trap (3/4" OD tubing) must be installed in the suction line. The "S" oil-trap must be located halfway between the icemaker and remote condensing unit. This ensures sufficient oil return to the compressor.

### 3. Line Set Installation

#### WARNING

- R-404A itself is not flammable at atmospheric pressure and temperatures up to 176°F (80°C).
- R-404A itself is not explosive or poisonous. However, when exposed to high temperatures (open flames), R-404A can be decomposed to form hydrofluoric acid and carbonyl fluoride both of which are hazardous.
- Do not use silver alloy or copper alloy containing arsenic.
- Do not open any service valve until the line set installation is complete and leak tested.
- Ensure that there are no unnecessary traps and no kinks in the line set.
- Do not coil extra line set.
- Use an electronic leak detector or soap bubbles to check for leaks. Add a trace of refrigerant to the line set tubing through the service valve access ports (if using an electronic leak detector), and then raise the pressure using nitrogen gas (140 PSIG). Do not use R-404A as a mixture with pressurized air for leak testing.

- 1) Route the factory line set or appropriate size copper tubing. When field fabricating, insulate the copper tubes separately. Leave a service loop behind the icemaker to allow the icemaker to be pulled out for service. See Fig. 14. Note: The service loop is not considered an oil trap.
- 2) Remove any extra line set length.
- 3) Choose the icemaker/line set configuration (top access or rear access). Use elbows as necessary. When using the top access holes, move the access covers to the rear access holes. See Fig. 14.
- 4) **NOTICE! Before brazing, remove the Schrader valve cores from the service valve access ports. When brazing, protect the service valve by using a wet cloth to prevent the service valve from overheating.**
- 5) Braze the line set to the icemaker service valves first, then to the remote condensing unit service valves.
- 6) Allow the service valves to cool, then replace the Schrader valve cores.
- 7) Use an electronic leak detector or soap bubbles to check for leaks. Add a trace of refrigerant to the line set tubing through the service valve access ports (if using an electronic leak detector), and then raise the pressure using nitrogen gas (140 PSIG). **WARNING! Do not use R-404A as a mixture with pressurized air for leak testing.**
- 8) Attach the gauge manifold hoses to the service valve access ports and evacuate the line set tubing. Allow the vacuum pump to pull down to a 29.9" Hg vacuum. Evacuating period depends on pump capacity. Next, charge each line set tube with R-404A vapor to a pressure of 15 to 30 PSIG.
- 9) Close both gauge manifold valves.
- 10) Disconnect the gauge manifold hoses.

- 11) Replace the access port caps and tighten.
  - 12) Open the icemaker service valves first, then open the remote condensing unit service valves.
  - 13) Replace the service valve caps and tighten.
  - 14) Insulate all exposed tubing and fittings.
- Hoshizaki Technical Support is available at 1-800-233-1940 for recommendations.

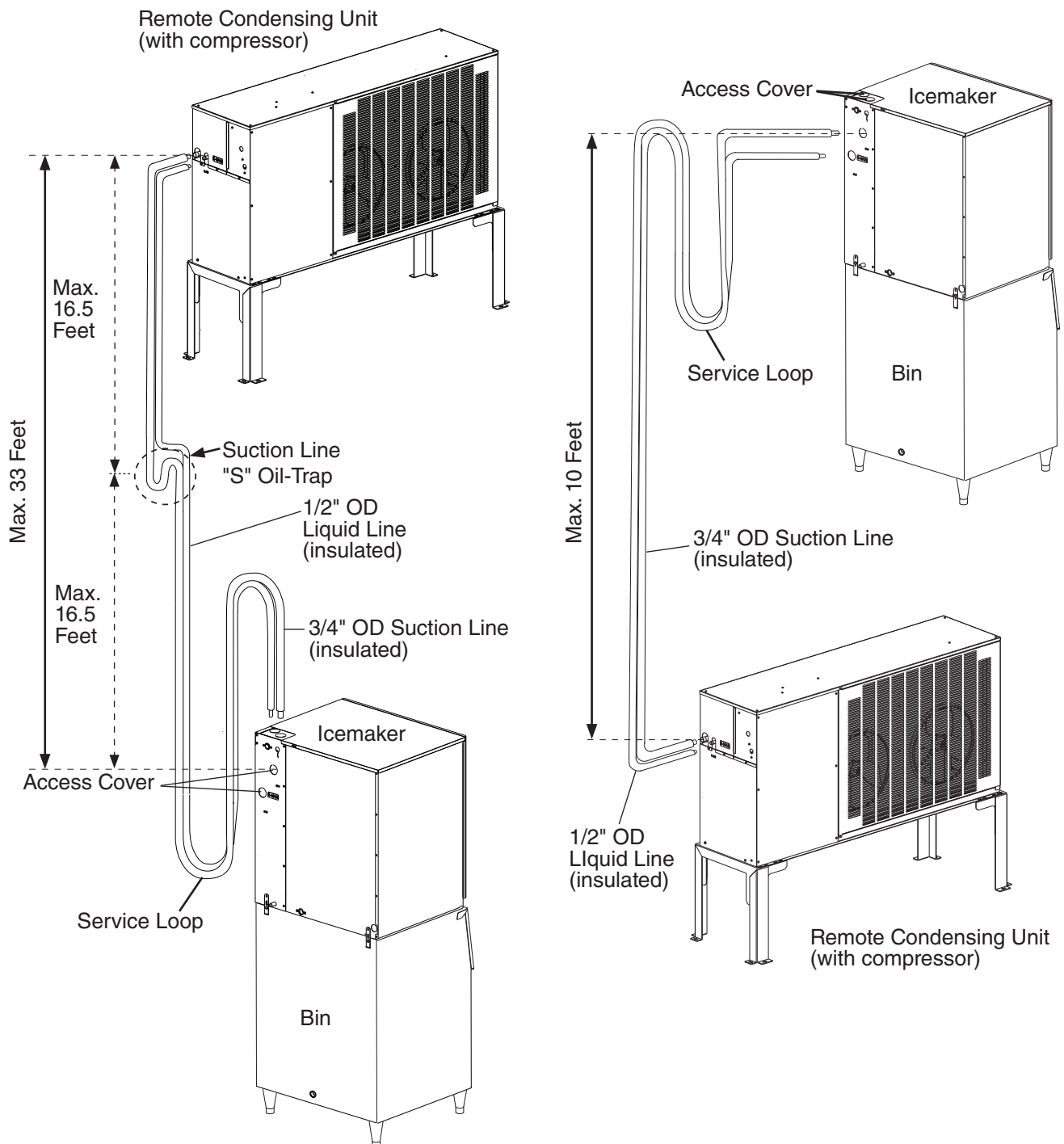

**Fig. 14**

## F. Electrical Connection

### **⚠ WARNING**

#### **Icemaker**

- Do not connect the icemaker to an external power source. Icemaker power supply and ground connection are supplied from the remote condensing unit via the wire bundle provided with the remote condensing unit.
- Wire bundle routing (conduit) and disconnect (if required) must meet national, state, and local electrical code requirements. If fabricating a wire bundle, use wire of an appropriate gage and outdoor rating. Failure to meet these code requirements could result in death, electric shock, serious injury, fire, or damage.
- **THE ICEMAKER MUST BE GROUNDED.** Failure to properly ground the icemaker could result in death or serious injury.
- To reduce the risk of electric shock, do not connect the remote condensing unit power supply until after all wire bundle connections have been made.

#### **Remote Condensing Unit**

- Remote condensing unit electrical connection must be hard-wired and must meet national, state, and local electrical code requirements. Failure to meet these code requirements could result in death, electric shock, serious injury, fire, or damage.
- The remote condensing unit requires an independent power supply of proper capacity. See the nameplate for electrical specifications. Failure to use an independent power supply of proper capacity can result in a tripped breaker, blown fuse, damage to existing wiring, or component failure. This could lead to heat generation or fire.
- **THE REMOTE CONDENSING UNIT MUST BE GROUNDED.** Failure to properly ground the remote condensing unit could result in death or serious injury.
- Remote condensing unit electrical connection must be made in accordance with the instructions on the "WARNING" tag provided with the pig tail leads in the remote condensing unit's power supply junction box. See Figs. 15a and 15b.

### **NOTICE**

The remote condensing unit must have power for a minimum of 4 hours prior to startup to prevent compressor damage.

- Usually an electrical permit and services of a licensed electrician are required.
- The maximum allowable voltage variation is  $\pm 10$  percent of the nameplate rating.
- The openings for the power supply and wire bundle connections are 7/8" DIA to fit a 1/2" trade size conduit.

- 1) Route the wire bundle between the icemaker and remote condensing unit. Use the wire bundle supplied with the remote condensing unit, or fabricate a wire bundle using wire of an appropriate gage and outdoor rating. Use the wiring label or Fig. 16 as a reference.
- 2a) Icemaker: Connect the wire bundle ground wire to the icemaker ground screw, then connect the rest of the wire bundle wires to the icemaker terminal block.  
**WARNING! Do not connect the wire bundle ground wire to the icemaker terminal block.**
- 2b) Remote Condensing Unit: Connect the wire bundle ground wire to the remote condensing unit ground screw (located next to the terminal block).  
**WARNING! Do not connect the wire bundle ground wire to the remote condensing unit terminal block.**
- 3) Connect the power supply from the disconnect or electrical panel to the leads in the remote condensing unit's power supply junction box. This differs from KM style installations. Connect a ground wire to the ground screw. See Figs. 15a and 15b.
  - On single phase models, the white lead must be connected to the neutral conductor of the power source. **NOTICE! Miswiring may result in severe damage to the icemaker.**
  - On three phase models, the transformer's voltage tap switch must be positioned to match incoming voltage at startup.
  - **NOTICE! On three phase models, connect the highest incoming voltage supply ("stinger leg") to the power wire dedicated to the compressor. See the wiring label on the remote condensing unit.**
- 4) Replace all removed parts and panels in their correct positions.
- 5) Turn on the power supply to the remote condensing unit. **NOTICE! The remote condensing unit must have power for a minimum of 4 hours prior to startup to prevent compressor damage.**

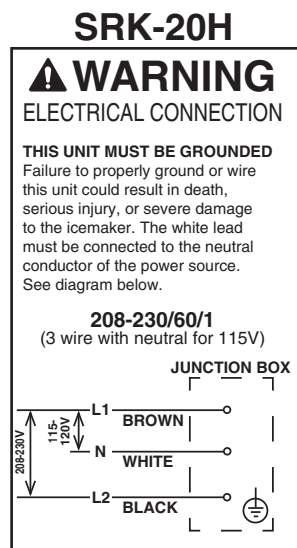

**Fig. 15a**

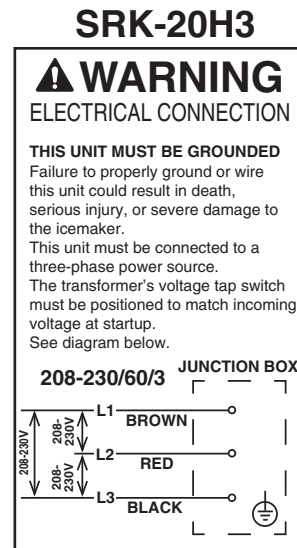
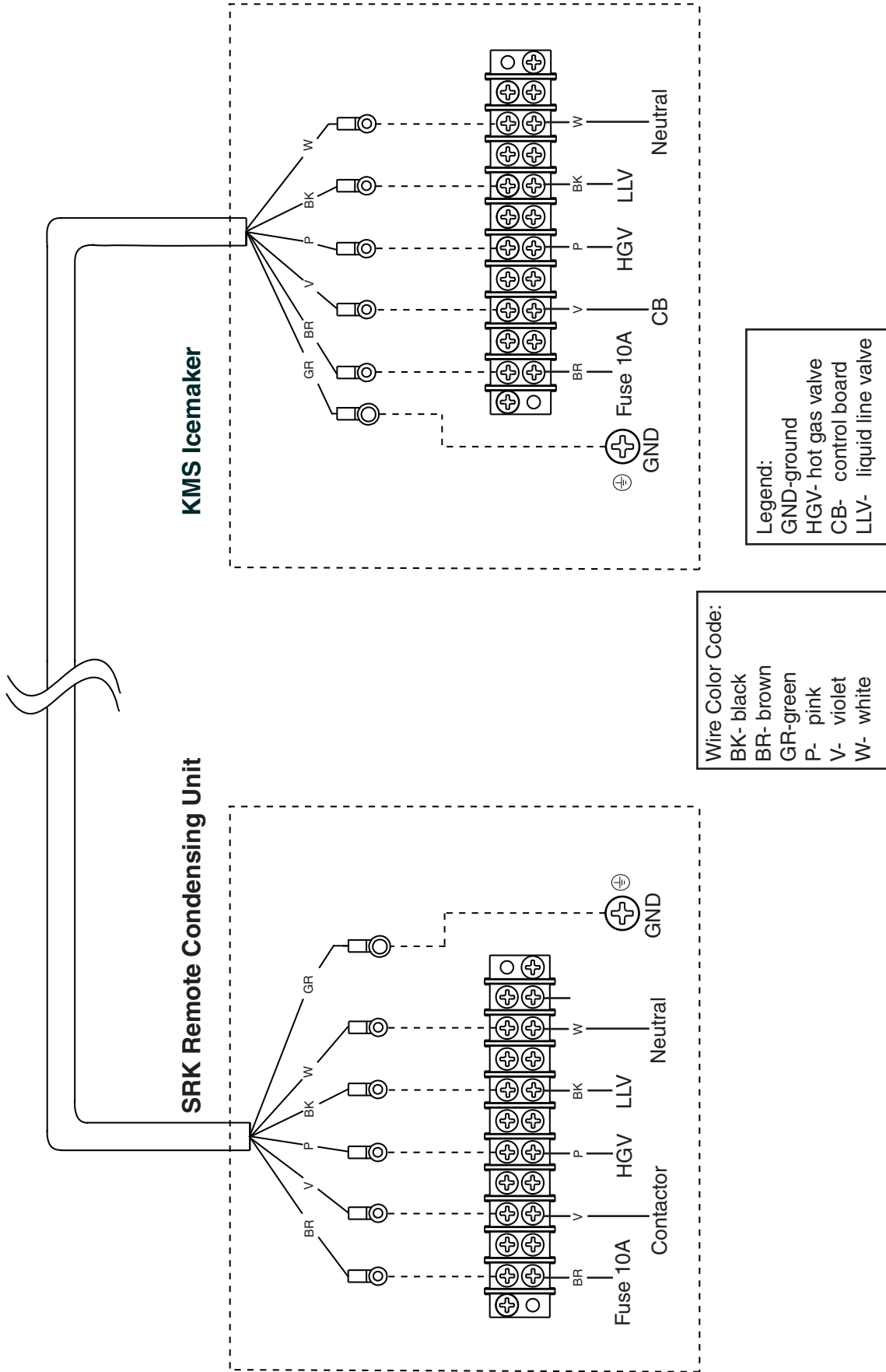

**Fig. 15b**

**Fig. 16**

**Icemaker-Remote Condensing Unit Wire Bundle Connections**

Use wire bundle supplied with the Remote Condensing Unit or fabricate a wire bundle using wire of an appropriate gage and outdoor rating.



## G. Water Supply and Drain Connections

See Fig. 17

### **⚠ WARNING**

Water supply and drain connections must be installed in accordance with applicable national, state, and local regulations.

### **NOTICE**

- Normal operating water temperature should be within 45°F to 90°F (7°C to 32°C). Operation of the icemaker, for extended periods, outside of this normal temperature range may affect icemaker performance.
- To prevent damage to equipment, do not operate the icemaker when the water supply is off, or if the pressure is below 10 PSIG. Do not run the icemaker until the proper water pressure is reached.

- A plumbing permit and services of a licensed plumber may be required in some areas.
- External filters, strainers, or softeners may be required depending on water quality. Contact your local Hoshizaki distributor for recommendations.
- Water supply pressure should be a minimum of 10 PSIG and a maximum of 113 PSIG. If the pressure exceeds 113 PSIG, the use of a pressure reducing valve is required.
- The icemaker and condensation drain line(s) and dispenser unit/storage bin drain line must be run separately.
- Drain lines must have 1/4" fall per foot (2 cm per 1 m) on horizontal runs to get a good flow. A vented tee connection is also required for proper flow.
- Drain lines should not be piped directly to the sewer system. An air gap of a minimum of 2 vertical inches (5 cm) should be between the end of the drain pipes from the icemaker, condensation drain, and dispenser unit/storage bin and the floor drain.

## 1. Icemaker

- Icemaker water supply inlet is 1/2" female pipe thread (FPT). A minimum of 3/8" nominal ID copper water tubing or equivalent is required for the icemaker water supply line.
- An icemaker water supply line shut-off valve and drain valve should be installed.
- Icemaker drain outlet is 3/4" FPT. A minimum of 3/4" nominal ID hard pipe or equivalent is required for the icemaker drain line. Condensation drain outlet is 5/8" OD hard tube. The condensation drain line can be connected to the icemaker drain line or can be run separately.

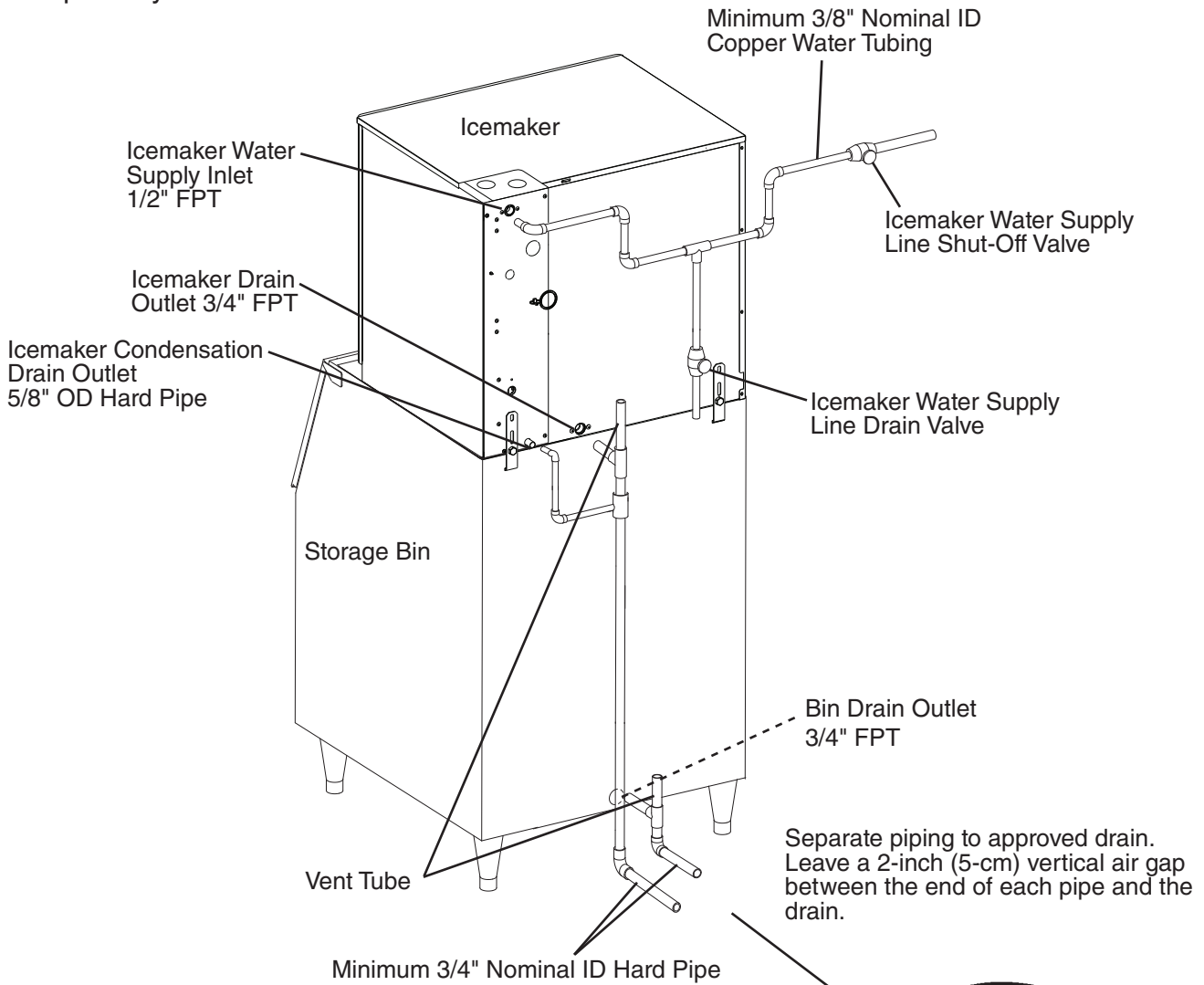

**KMS-2000MLH**

**Fig. 17**

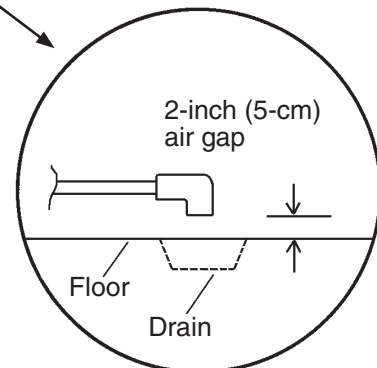

## H. Final Checklist

### **WARNING**

**CHOKING HAZARD:** Ensure all components, fasteners, and thumbscrews are securely in place after installation. Make sure that none have fallen into the dispenser unit/storage bin.

- 1) Is the icemaker level?
- 2) Is the icemaker in a site where the ambient temperature is within 45°F to 100°F (7°C to 38°C) and the water temperature within 45°F to 90°F (7°C to 32°C) all year around?
- 3) Is there at least 6" (15 cm) clearance at sides, rear, and top of the icemaker for proper air circulation and ease of maintenance and service?
- 4) Is there at least 24" (61 cm) clearance around the remote condensing unit for proper air circulation and ease of maintenance and service?
- 5) Have the shipping carton, tape, and packing material been removed from the icemaker and remote condensing unit? Are the cube guides and tank separator in their correct positions?
- 6) Have all water tank hoses been reconnected after installing the bin control?  
Note: On dispenser unit applications, confirm that there is no gap between the switch mount and the dispenser unit bin wall. On storage bins, make sure there is no gap between the switch mount and the bin wall, extension bracket, or brace.
- 7) Have all required areas been properly sealed with RTV-748 sealant or equivalent?
- 8) Have all electrical and water connections been made? Do electrical and water connections meet all national, state, and local code and regulation requirements?
- 9) Has the power supply voltage been checked or tested against the nameplate rating?  
Has a proper ground been installed to the remote condensing unit and icemaker unit?  
On three phase model, has the transformer's voltage tap switch been positioned to match incoming voltage? For details, see "II.F. Electrical Connection."
- 10) Has the electrical power supply been on to the remote condensing unit for a minimum of 4 hours?
- 11) Are the water supply line shut-off valve and drain valve installed? Has the water supply pressure been checked to ensure a minimum of 10 PSIG and a maximum of 113 PSIG?  
Note: The icemaker may stop running when the water supply is off, or if the pressure is below 10 PSIG. When the proper water pressure is reached, the icemaker automatically starts running again.
- 12) Are the compressor hold-down bolts snug? Have the refrigerant lines been checked to make sure they do not rub or touch other lines or surfaces? Have the fan blades been checked to make sure they turn freely?
- 13) Is the line set free of leaks and kinks? If needed, has an "S" oil-trap been installed?
- 14) Are all components, fasteners, and thumbscrews securely in place?
- 15) Has the end user been given the instruction manual, and instructed on how to operate the icemaker and the importance of the recommended periodic maintenance?

- 16) Has the end user been given the name and telephone number of an authorized service agent?
- 17) Has the warranty card been filled out and forwarded to the factory for warranty registration?

## I. Startup

### **⚠ WARNING**

All parts are factory-adjusted. Improper adjustments may adversely affect safety, performance, component life, and warranty coverage.

### **NOTICE**

- If the unit is turned off, wait for at least 3 minutes before restarting the unit to prevent damage to the compressor.
- To prevent damage to the water pump seal, do not leave the control switch in the "SERVICE" position when the water tank is empty.
- At startup, confirm that all internal and external connections are free of leaks.
- The remote condensing unit must have power for a minimum of 4 hours prior to startup to prevent compressor damage.

- 1) If removed, replace the splash curtain, front frame, and all panels except the front panel in their correct positions. See Fig. 18. If not already removed, remove the front panel.
- 2) Open the water supply line shut-off valve.
- 3) Move the control switch to the "ICE" position, then replace the front panel in its correct position.
- 4) Turn on the power supply, and allow the water tank to fill with water and the icemaker to operate for a total of 10 minutes.
- 5) After 10 minutes of operation, confirm bin control operation. Remove the front panel, then press and hold the bin control's actuator paddle. The compressor and fan motor should de-energize within 15 seconds, then the drain valve should energize until the water tank empties. After the water tank empties, the pump motor and drain valve should de-energize.
- 6) Move the control switch to the "OFF" position, then turn off the power supply.
- 7) Remove the insulation panel, front frame, and splash curtain.
- 8) Finish draining the water tank by disconnecting the pump suction hose at the evaporator case wall.
- 9) Disconnect the drain pipe and float connection hose at the evaporator case wall. Disconnect the water tank drain hose from the bottom of the water tank.
- 10) Remove the water tank.
- 11) Clean the dispenser unit/storage bin liner and water tank using a neutral cleaner. Rinse thoroughly after cleaning.
- 12) Replace the water tank in the icemaker, then reconnect the hoses and drain pipe.

- 13) Replace the splash curtain, front frame, and insulation panel in their correct positions and secure with the thumbscrews.
- 14) Seal the outer perimeter of the front frame to the icemaker and dispenser unit/storage bin with RTV-748 sealant (provided) or equivalent. See Fig. 19. Make sure the front frame sealant meets the previously applied perimeter sealant and that there are no gaps.
- 15) Move the control switch to the "ICE" position.
- 16) Replace the front panel in its correct position.
- 17) Turn on the power supply to start the automatic icemaking process.

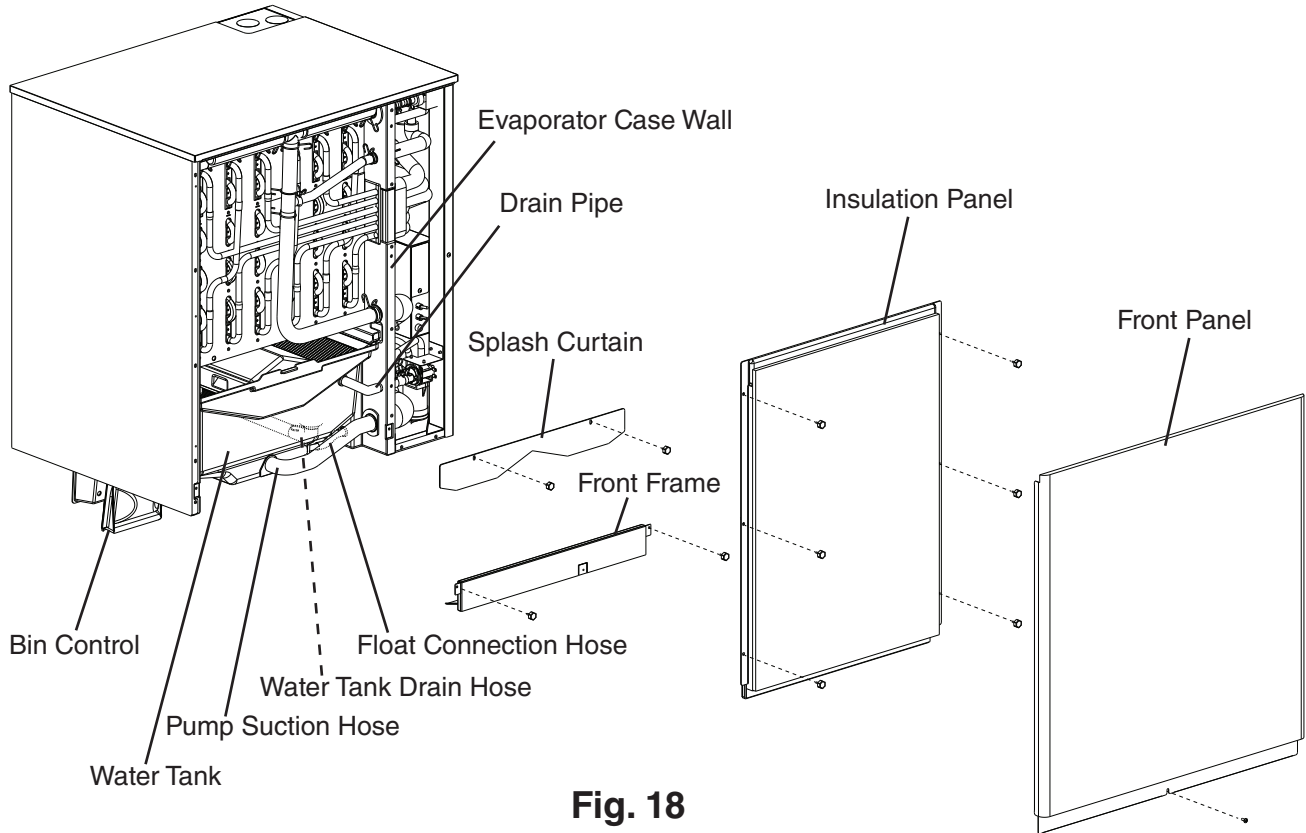

**Fig. 18**

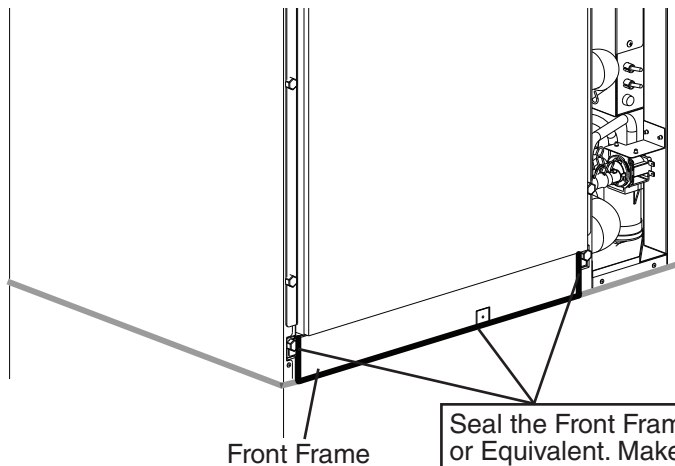

Seal the Front Frame Outer Perimeter with RTV-748 Sealant or Equivalent. Make sure the front frame sealant meets the previously applied perimeter sealant and that there are no gaps.

**Fig. 19**

### III. Cleaning and Maintenance

This icemaker must be cleaned and maintained in accordance with the instruction manual and labels provided with the icemaker. Consult with your local Hoshizaki Certified Service Representative about cleaning and maintenance service.

#### **⚠ WARNING**

- Only qualified service technicians should service this icemaker.
- **CHOKING HAZARD:** Ensure all components, fasteners, and thumbscrews are securely in place after any cleaning or maintenance is done to the unit. Make sure that none have fallen into the dispenser unit/storage bin.

#### **NOTICE**

The dispenser unit/storage bin is for ice use only. Do not store anything else in the dispenser unit/storage bin.

### A. Cleaning and Sanitizing Instructions

This icemaker must be cleaned and sanitized at least once a year. More frequent cleaning and sanitizing may be required in some water conditions.

#### **⚠ WARNING**

- To prevent injury to individuals and damage to the icemaker, do not use ammonia type cleaners.
- Carefully follow any instructions provided with the bottles of cleaning and sanitizing solution.
- Always wear liquid-proof gloves and goggles to prevent the cleaning and sanitizing solutions from coming into contact with skin or eyes.

#### **NOTICE**

To prevent damage to the water pump seal, do not operate the icemaker with the control switch in the "SERVICE" position when the water tank is empty.

**Fig. 20**

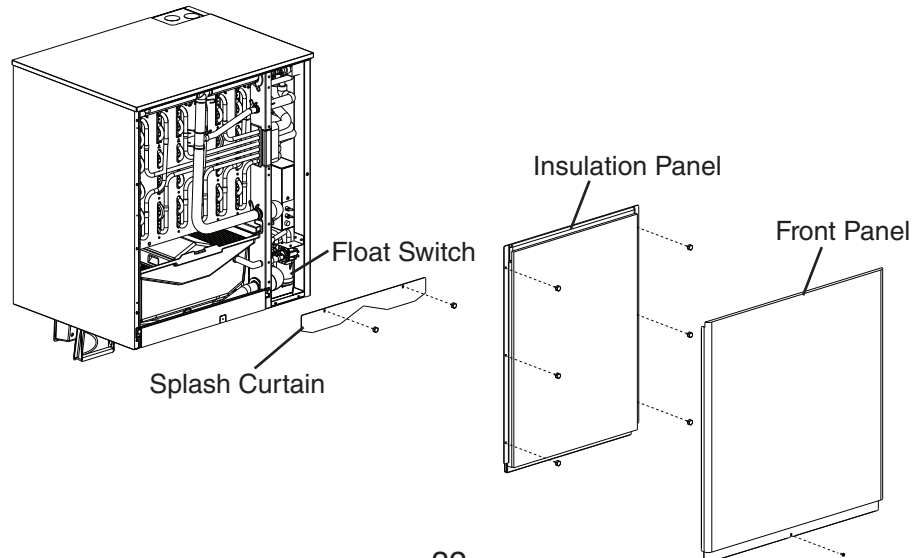

## 1. Cleaning Procedure

- 1) Dilute 27 fl. oz. (800 ml) of Hoshizaki "Scale Away" with 5 gal. (19 l) of warm water.
- 2) Remove all ice from the evaporator and the dispenser unit/storage bin.  
Note: To remove cubes on the evaporator, turn off the power supply and turn it back on after 3 minutes. The harvest cycle starts and the cubes will be removed from the evaporator.
- 3) Turn off the power supply.
- 4) Remove the front panel, then place the control switch in the "SERVICE" position. Place the service switch in the "DRAIN" position.
- 5) Replace the front panel in its correct position, then turn on the power supply for 2 minutes.
- 6) Turn off the power supply.
- 7) Remove the front panel.
- 8) In bad or severe water conditions, clean the float switch as described below. Otherwise, continue to step 9.
  - a. Remove the right side panel.
  - b. Disconnect the flush tube from the top of the float switch housing, then remove the float switch assembly. Remove the rubber boot from the bottom of the assembly.
  - c. Remove the retainer rod from the bottom of the float switch housing, then remove the float. Be careful not to bend the retainer rod excessively when removing it.
  - d. Wipe down the float switch assembly's housing, shaft, float, and retainer rod with cleaning solution. Clean the inside of the rubber boot and hose with cleaning solution. Rinse the parts thoroughly with clean water.
  - e. Reassemble the float switch assembly and replace it and the rubber boot in their correct positions. Reconnect the flush tube.
  - f. Replace the right side panel in its correct position.
- 9) Remove the insulation panel and splash curtain, then pour the cleaning solution into the water tank.
- 10) Move the service switch to the "WASH" position.
- 11) Replace the splash curtain, insulation panel, and front panel in their correct positions.
- 12) Turn on the power supply to start the washing process.
- 13) Turn off the power supply after 30 minutes. Remove the front panel.
- 14) Move the service switch to the "DRAIN" position.
- 15) Replace the front panel in its correct position, then turn on the power supply for 2 minutes.
- 16) Turn off the power supply, then remove the front panel.
- 17) Move the control switch to the "ICE" position.
- 18) Replace the front panel in its correct position.
- 19) Turn on the power supply to fill the water tank with water.
- 20) Turn off the power supply after 3 minutes.

- 21) Remove the front panel.
- 22) Move the control switch to the "SERVICE" position, then move the service switch to the "WASH" position.
- 23) Replace the front panel in its correct position.
- 24) Turn on the power supply to rinse off the cleaning solution.
- 25) Turn off the power supply after 5 minutes.
- 26) Remove the front panel.
- 27) Move the service switch to the "DRAIN" position.
- 28) Replace the front panel in its correct position, then turn on the power supply for 2 minutes.
- 29) Turn off the power supply. Remove the front panel.
- 30) Repeat steps 17 through 29 three more times to rinse thoroughly.  
Note: If you do not sanitize the icemaker, go to step 13 in "2. Sanitizing Procedure."

## **2. Sanitizing Procedure - Following Cleaning Procedure**

- 1) Dilute 2.5 fl. oz. (74 ml or 5 tbs) of a 5.25% sodium hypochlorite solution (chlorine bleach) with 5 gal. (19 l) of warm water.
- 2) Remove the front panel, insulation panel, and splash curtain if they are in their normal positions.
- 3) Pour the sanitizing solution into the water tank.
- 4) Move the service switch to the "WASH" position.
- 5) Replace the splash curtain, insulation panel, and front panel in their correct positions.
- 6) Turn on the power supply to start the sanitizing process.
- 7) Turn off the power supply after 15 minutes. Remove the front panel.
- 8) Move the service switch to the "DRAIN" position.
- 9) Replace the front panel in its correct position, then turn on the power supply for 2 minutes.
- 10) Turn off the power supply. Remove the front panel.
- 11) Repeat steps 17 through 29 in "1. Cleaning Procedure" two times to rinse thoroughly.
- 12) Repeat steps 1 through 11 one more time.
- 13) Move the control switch to the "ICE" position.
- 14) Replace the front panel in its correct position.
- 15) Clean the dispenser unit/storage bin liner using a neutral cleaner. Rinse thoroughly after cleaning.
- 16) Turn on the power supply to start the automatic icemaking process.

## B. Maintenance

This icemaker must be maintained individually, referring to the instruction manual and labels provided with the icemaker.

### **WARNING**

- Only qualified service technicians should service this icemaker.
- Move the control switch to the "OFF" position and turn off the power supply to the remote condensing unit before servicing. Place the icemaker disconnect (if applicable) in the off position. Lockout/Tagout to prevent the power supply from being turned back on inadvertently.

#### 1. Stainless Steel Exterior

To prevent corrosion, wipe the exterior occasionally with a clean, soft cloth. Use a damp cloth containing a neutral cleaner to wipe off oil or dirt buildup.

#### 2. Storage Bin Scoop

- Wash your hands before removing ice from the storage bin. Use the plastic scoop provided (storage bin accessory).
- Clean the scoop using a neutral cleaner. Rinse thoroughly after cleaning.

#### 3. Dispenser Unit/Storage Bin

- The dispenser unit/storage bin is for ice use only. Do not store anything else in the dispenser unit/storage bin.
- Clean the dispenser unit/storage bin liner using a neutral cleaner. Rinse thoroughly after cleaning.

#### 4. Condenser

Check the condenser once a year, and clean the coil if required by using a brush or vacuum cleaner. More frequent cleaning may be required depending on location.

## C. Preparing the Icemaker for Periods of Non-Use

### **NOTICE**

- When storing the icemaker for an extended time or in sub-freezing temperatures, follow the instructions below to prevent damage.
- To prevent damage to the water pump, do not operate the icemaker with the control switch in the "SERVICE" position when the water tank is empty.

When the icemaker is not used for two or three days under normal conditions, it is sufficient to move the control switch to the "OFF" position. When storing the icemaker for an extended time or in sub-freezing temperatures, follow the instructions below.

#### **1. Remove the water from the icemaker water lines:**

- 1) Turn off the power supply, then remove the front panel, right side panel, and control box cover.
- 2) Move the control switch on the control box to the "OFF" position. Confirm the service switch is in the "CIRC" position.
- 3) Close the icemaker water supply line shut-off valve and open the icemaker water supply line drain valve. Allow the line to drain by gravity.
- 4) Attach a compressed air or carbon dioxide supply to the icemaker water supply line drain valve.
- 5) Turn on the power supply, then move the control switch to the "ICE" position. Confirm that the bin control switch is closed and calling for ice. The "POWER OK" LED should be on and not flashing.
- 6) Blow the icemaker water supply line out using the compressed air or carbon dioxide supply. This will clear water from the inlet water valve.
- 7) Move the control switch to the "OFF" position.
- 8) Disconnect the wash valve hose from the inlet water valve tee, then unplug the water pump connector at the water pump. See Fig. 21.
- 9) Move the service switch to the "WASH" position, then move the control switch to the "SERVICE" position.
- 10) From the wash valve hose, blow out the wash valve using the compressed air or carbon dioxide supply. Reconnect the wash valve hose.
- 11) Move the service switch to the "CIRC" position, then move the control switch to the "OFF" position.
- 12) Disconnect the float switch vent hose from the drain hose tee. Move the service switch to the "DRAIN" position, then move the control switch to the "SERVICE" position.
- 13) From the drain hose tee, blow out the drain valve using the compressed air or carbon dioxide supply. Reconnect the float switch vent hose.
- 14) Move the service switch to the "CIRC" position, then move the control switch to the "OFF" position.
- 15) Turn off the power supply, then reconnect the water pump connector.
- 16) Close the icemaker water supply line drain valve.

## 2. Remove the water from the water tank:

- 17) Remove the insulation panel and front frame.
- 18) Disconnect the hoses connected to the water tank. Allow the tank and hoses to drain completely. See Fig. 22.
- 19) Remove all ice from the dispenser unit/storage bin and clean the dispenser unit/storage bin liner using a neutral cleaner. Rinse thoroughly after cleaning.
- 20) Reconnect the hoses to the water tank.
- 21) Replace all removed parts and panels in their correct positions.

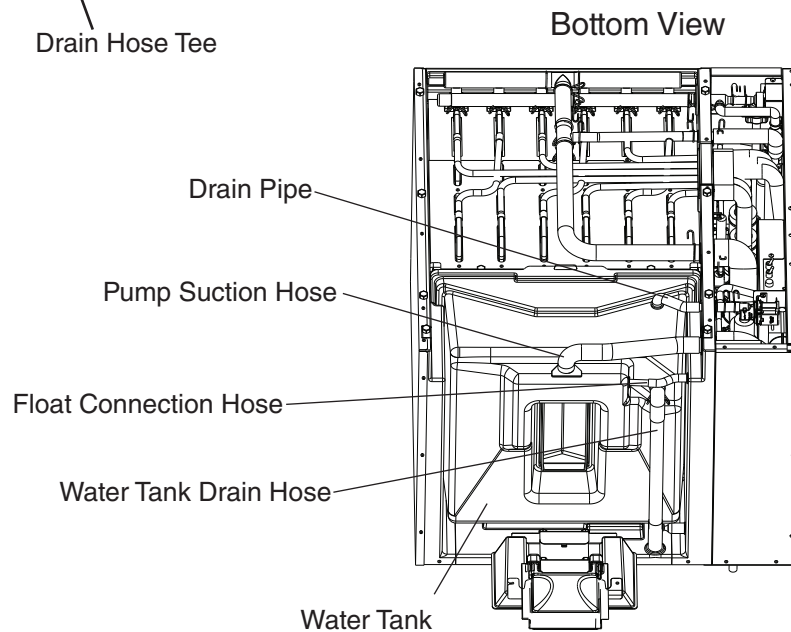
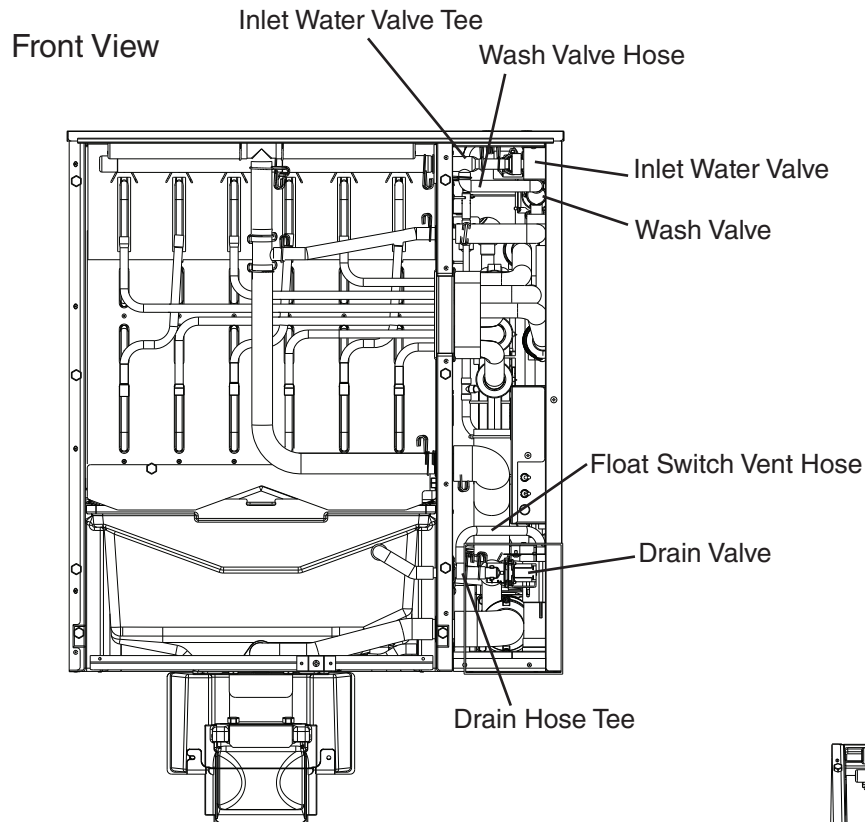

**HOSHIZAKI AMERICA, INC.**

---

618 Hwy. 74 South, Peachtree City, GA 30269 USA (P) 770.487.2331 (F) 770.487.3360 [hoshizakiamerica.com](http://hoshizakiamerica.com) 1A3071-011