



HOSHIZAKI

Service Manual

Modular Crescent Cuber

Model
KMS-1401MLJ

Including
Condensing Unit Models
SRK-14J/3



hoshizakiamerica.com

Number: 73192
Issued: 7-25-2017
Revised: 7-25-2017

⚠ WARNING

Only qualified service technicians should install and service the appliance. To obtain the name and phone number of your local Hoshizaki Certified Service Representative, visit www.hoshizaki.com. No installation or service should be undertaken until the technician has thoroughly read this Service Manual. Likewise, the owner/manager should not proceed to operate the appliance until the installer has instructed them on its proper operation. Failure to install, operate, and maintain the appliance in accordance with this manual will adversely affect safety, performance, component life, and warranty coverage and may result in costly water damage. Proper installation is the responsibility of the installer. Product failure or property damage due to improper installation is not covered under warranty.

Hoshizaki provides this manual primarily to assist qualified service technicians in the installation, maintenance, and service of the appliance.

Should the reader have any questions or concerns which have not been satisfactorily addressed, please call, send an e-mail message, or write to the Hoshizaki Technical Support Department for assistance.

Phone: 1-800-233-1940; (770) 487-2331

Fax: 1-800-843-1056; (770) 487-3360

E-mail: techsupport@hoshizaki.com

HOSHIZAKI AMERICA, INC.

618 Highway 74 South

Peachtree City, GA 30269

Attn: Hoshizaki Technical Support Department

NOTE: To expedite assistance, all correspondence/communication **MUST** include the following information:

- Model Number _____
- Serial Number _____
- Complete and detailed explanation of the problem.

IMPORTANT

This manual should be read carefully before the icemaker is serviced. Read the warnings and guidelines contained in this booklet carefully as they provide essential information for the continued safe use, service, and maintenance of the icemaker. Retain this booklet for any further reference that may be necessary.

CONTENTS

Important Safety Information	5
I. Specifications.....	7
A. Icemaker	7
1. KMS-1401MLJ with SRK-14J	7
2. KMS-1401MLJ with SRK-14J3	8
B. Condensing Unit.....	9
1. SRK-14J.....	9
2. SRK-14J3	10
II. General Information	11
A. Construction	11
1. Icemaker	11
2. Condensing Unit	12
B. Sequence of Operation	13
1. Sequence Cycles and Shutdown	13
a) 1-Minute Fill Cycle	13
b) Initial Harvest Cycle	13
c) Freeze Cycle	13
d) Pump-Out Cycle.....	14
e) Harvest Cycle	14
f) Shutdown.....	14
2. Sequence Flow Chart.....	15
C. Control Board	16
1. Control Board Layout	17
2. LED Lights and Audible Alarm Safeties	18
3. Controls and Adjustments.....	19
a) Default Dip Switch Settings.....	19
b) Harvest Timer (S4 dip switch 1 & 2).....	19
c) Pump-Out Timer (S4 dip switch 3 & 4)	20
d) Pump-Out Frequency Control (S4 dip switch 5 & 6).....	20
e) Harvest Pump Timer (S4 dip switch 7).....	21
f) Factory Use (S4 dip switch 8)	21
g) Freeze Timer (S4 dip switch 9 & 10)	21
h) Float Switch Selector (S5 dip switch 1).....	22
i) Refill Counter (S5 dip switch 2 through 5).....	22

D. Control and Service Switches	23
1. Control Switch	23
2. Service Switch	23
a) DRAIN.....	23
b) CIRC.	23
c) WASH.....	23
III. Technical Information	24
A. Water Circuit and Refrigeration Circuit	24
B. Wiring Diagrams.....	25
1. KMS-1401MLJ with SRK-14J	25
2. KMS-1401MLJ with SRK-14J3	26
3. Wire Harness Connections.....	27
C. Performance Data	28
1. KMS-1401MLJ with SRK-14J	28
2. KMS-1401MLJ with SRK-14J3	29
IV. Service Diagnosis	30
A. Diagnostic Procedure	30
B. Control Board Check	34
C. Bin Control Check and Cleaning	35
1. Bin Control Check	35
2. Bin Control Cleaning.....	36
D. Float Switch Check and Cleaning	37
1. Float Switch Check	37
2. Float Switch Cleaning.....	38
E. Thermistor Check.....	39
F. Diagnostic Charts	40
1. No Ice Production.....	40
2. Freeze-Up.....	41
3. Low Ice Production	43
V. Replacement of Components	44
A. Service for Refrigerant Lines.....	44
1. Refrigerant Recovery	44
2. Brazing	45
3. Evacuation and Recharge (R-404A).....	45
B. Important Notes for Component Replacement.....	47
VI. Cleaning and Maintenance	48
A. Cleaning and Sanitizing Instructions	48
1. Cleaning Procedure.....	49
2. Sanitizing Procedure - Following Cleaning Procedure	50
B. Maintenance.....	51
C. Preparing the Icemaker for Periods of Non-Use.....	52
VII. Disposal.....	54

Important Safety Information

Throughout this manual, notices appear to bring your attention to situations which could result in death, serious injury, damage to the icemaker, or damage to property.

⚠ WARNING Indicates a hazardous situation which could result in death or serious injury.

NOTICE Indicates a situation which could result in damage to the appliance or property.

IMPORTANT Indicates important information about the use and care of the appliance.

⚠ WARNING

This icemaker should be destined only to the use for which it has been expressly conceived. Any other use should be considered improper and therefore dangerous. The manufacturer cannot be held responsible for injury or damage resulting from improper, incorrect, and unreasonable use. Failure to service and maintain the appliance in accordance with this manual will adversely affect safety, performance, component life, and warranty coverage and may result in costly water damage.

To reduce the risk of death, electric shock, serious injury, or fire, follow basic precautions including the following:

- Only qualified service technicians should install and service this icemaker.
- This icemaker must be installed in accordance with applicable national, state, and local codes and regulations. Failure to meet these code requirements could result in death, electric shock, serious injury, fire, or damage to the appliance.
- To reduce the risk of electric shock, do not touch the control switch or service switch with damp hands.
- Before Servicing the KMS or SRK: To reduce the risk of electric shock, move the control switch to the "OFF" position and turn off the power supply to the SRK condensing unit. Place the KMS disconnect (if applicable) in the "OFF" position. Lockout/Tagout to prevent the power supply from being turned back on inadvertently.
- Do not make any alterations to the icemaker. Alterations could result in electric shock, injury, fire, or damage to the icemaker.
- This appliance is not intended for use by persons (including children) with reduced physical, sensory, or mental capabilities, or lack of experience and knowledge, unless they have been given supervision or instruction concerning use of the appliance by a person responsible for their safety.
- Children should be properly supervised around this appliance.
- Do not climb, stand, or hang on the icemaker or allow children or animals to do so. Serious injury could occur or the icemaker could be damaged.
- Do not use combustible spray or place volatile or flammable substances near the icemaker. They might catch fire.
- Keep the area around the icemaker clean. Dirt, dust, or insects in the icemaker could cause harm to individuals or damage to the icemaker.

⚠ WARNING, continued

For KMS

- Power supply and ground connection are supplied from the SRK remote condensing unit via the wire harness provided. Do not connect the wire harness leads to an external power source.
- Wire harness routing (conduit) and disconnect (if required) must meet national, state, and local electrical code requirements. Failure to meet these code requirements could result in death, electric shock, serious injury, fire, or damage to the appliance.
- **THE ICEMAKER MUST BE GROUNDED.** Failure to properly ground the icemaker could result in death, serious injury, or damage to the appliance.

For SRK

- Electrical connection must be hard-wired and must meet national, state, and local electrical code requirements. Failure to meet these code requirements could result in death, electric shock, serious injury, fire, or damage to the appliance.
- The remote condensing unit requires an independent power supply of proper capacity. See the nameplate for electrical specifications. Failure to use an independent power supply of proper capacity can result in a tripped breaker, blown fuses, damage to existing wiring, or component failure. This could lead to heat generation or fire.
- **THE REMOTE CONDENSING UNIT MUST BE GROUNDED.** Failure to properly ground the remote condensing unit could result in death, serious injury, or damage to the appliance.

NOTICE

- Follow the instructions in this manual carefully to reduce the risk of costly water damage.
- In areas where water damage is a concern, install in a contained area with a floor drain.
- Install the icemaker in a location that stays above freezing. Normal operating ambient temperature must be within 45°F to 100°F (7°C to 38°C).
- Do not leave the icemaker on during extended periods of non-use, extended absences, or in sub-freezing temperatures. To properly prepare the icemaker for these occasions, follow the instructions in "VI.C. Preparing the Icemaker for Periods of Non-Use."
- Do not place objects on top of the icemaker.
- The dispenser unit/storage bin is for ice use only. Do not store anything else in the dispenser unit/storage bin.

I. Specifications

A. Ice maker

1. KMS-1401MLJ with SRK-14J

AC SUPPLY VOLTAGE	115VAC Supplied by SRK-14J via Factory Supplied Wire Harness			
APPROXIMATE ICE PRODUCTION PER 24 HR. lb./day (kg/day) Reference without *marks	Ambient Temp.(°F)	WATER TEMP. (°F)		
		50	70	90
	70	*1420 (644)	1379 (626)	1278 (580)
	80	1389 (630)	1325 (601)	1199 (544)
	90	1379 (626)	*1280 (581)	1162 (527)
	100	1344 (609)	1252 (568)	1054 (478)
SHAPE OF ICE	Crescent Cube			
ICE PRODUCTION PER CYCLE	25.8 lb. (11.7 kg) 1248pcs.			
ELECTRIC & WATER CONSUMPTION	90/70°F	70/50°F		
KMS/SRK COMBINED ELECTRIC W (kWH/100 lb.)	2510(4.70)	2410(4.07)		
WATER gal./24HR (gal./100 lb.)	250(19.5)	682(48.0)		
CEE TIER	1			
ENERGY STAR	YES			
EXTERIOR DIMENSIONS (WxDxH)	30"x24"x28" (762x610x711 mm)			
EXTERIOR FINISH	Stainless Steel, Galvanized Steel (Rear)			
WEIGHT	Net 143 lb. (65 kg), Shipping 177 lb. (80 kg)			
CONNECTIONS - ELECTRIC	Wire Harness Connection from SRK to KMS			
- WATER SUPPLY	Inlet	1/2" FPT		
- DRAIN	Outlet	3/4" FPT		
-CONDENSATION DRAIN OUTLET		5/8" OD Hard Tube		
-REFRIGERATION	Liquid Line	1 1/16" - 12 UNF Fitting (#10 Parker)		
	Suction Line	1 1/8" - 12 UNF Fitting (#11 Parker)		
CUBE CONTROL SYSTEM	Float Switch			
HARVESTING CONTROL SYSTEM	Hot Gas and Water, Thermistor and Timer			
ICE MAKING WATER CONTROL	Timer Controlled, Overflow Pipe, and Float Switch			
COOLING WATER CONTROL	N/A			
BIN CONTROL SYSTEM	Mechanical Bin Control			
COMPRESSOR	In SRK			
CONDENSER	Air-Cooled Remote Condensing Unit SRK-14J			
EVAPORATOR	Vertical Type, Stainless Steel and Copper			
REFRIGERANT CONTROL	Thermostatic Expansion Valve			
	Headmaster (C.P.R.) in SRK-14J (160 PSI)			
REFRIGERANT CHARGE	R404A, 16 lb. 5 oz. (7400g) (Ice maker 0 lb. 7.1 oz. (200g)) (Cond. Unit 15 lb. 14 oz. (7200g))			
DESIGN PRESSURE	High 467PSIG, Low 230PSIG			
CONTROL BOARD CIRCUIT PROTECTION	High Voltage Cut-Out (Internal)			
REFRIGERANT CIRCUIT PROTECTION	Auto-Reset High-Pressure Switch in SRK-14J Auto-Reset Discharge Line Thermostat in SRK-14J			
LOW WATER PROTECTION	Float Switch			
ACCESSORIES -SUPPLIED	N/A			
-REQUIRED	Dispenser Unit or Ice Storage Bin SRK-14J Remote Condensing Unit			
OPERATING CONDITIONS	VOLTAGE RANGE	187-253VAC		
	AMBIENT TEMP.	45-100°F		
	WATER SUPPLY TEMP.	45-90°F		
	WATER SUPPLY PRESSURE	10-113 PSIG		

Note: We reserve the right to make changes in specifications and design without prior notice.

2. KMS-1401MLJ with SRK-14J3

Specification Sheet

AC SUPPLY VOLTAGE	115VAC Supplied by SRK-14J3 via Factory Supplied	
	Wire Harness	
ELECTRIC & WATER CONSUMPTION	90/70°F	70/50°F
KMS/SRK COMBINED ELECTRIC		
W (kWH/100 lb.)	2510 (4.70)	2470 (4.23)
WATER gal./24HR (gal./100 lb.)	256 (20.0)	757 (54.1)
ICE PRODUCTION PER CYCLE	26.7 lb. (12.1 kg) 1248pcs.	
BIN CONTROL SYSTEM	Mechanical Bin Control	
REFRIGERANT CHARGE	R404A, 16 lb. 5 oz. (7400g) (Icemaker 0 lb. 7.1 oz. (200g)) (Cond. Unit 15 lb. 14 oz. (7200g))	

Performance Data Sheet

APPROXIMATE ICE PRODUCTION PER 24 HR.	AMBIENT TEMP. (°F/°C)	WATER TEMP. (°F/°C)					
		50/10		70/21		90/32	
	70/21	1400	<u>635</u>	1365	<u>619</u>	1266	<u>574</u>
	80/27	1373	<u>623</u>	1319	<u>598</u>	1191	<u>540</u>
	90/32	1365	<u>619</u>	1280	<u>581</u>	1163	<u>527</u>
lbs./day <u>kg./day</u>	100/38	1328	<u>602</u>	1253	<u>568</u>	1055	<u>479</u>
APPROXIMATE ELECTRIC CONSUMPTION	70/21	2470		2482		2528	
	80/27	2479		2497		2561	
	90/32	2482		2510		2567	
watts	100/38	2501		2523		2620	
APPROXIMATE WATER CONSUMPTION PER 24 HR.	70/21	757	<u>2.87</u>	611	<u>2.31</u>	534	<u>2.02</u>
	80/27	645	<u>2.44</u>	417	<u>1.58</u>	410	<u>1.55</u>
	90/32	611	<u>2.31</u>	256	<u>0.97</u>	218	<u>0.82</u>
gal./day <u>m³/day</u>	100/38	442	<u>1.67</u>	247	<u>0.94</u>	183	<u>0.69</u>
FREEZING CYCLE TIME	70/21	24		25		28	
	80/27	25		27		30	
	90/32	25		28		31	
min.	100/38	26		29		33	
HARVEST CYCLE TIME	70/21	5.3		4.4		4.1	
	80/27	4.6		3.3		3.4	
	90/32	4.4		2.3		2.2	
min.	100/38	3.5		2.3		2.1	
HEAD PRESSURE	70/21	175	<u>12.3</u>	197	<u>13.8</u>	221	<u>15.5</u>
	80/27	192	<u>13.5</u>	226	<u>15.9</u>	246	<u>17.3</u>
	90/32	197	<u>13.8</u>	250	<u>17.6</u>	272	<u>19.2</u>
PSIG <u>kg/cm²G</u>	100/38	200	<u>14.0</u>	255	<u>17.9</u>	293	<u>20.6</u>
SUCTION PRESSURE	70/21	46	<u>3.2</u>	48	<u>3.4</u>	52	<u>3.6</u>
	80/27	48	<u>3.3</u>	51	<u>3.6</u>	55	<u>3.9</u>
	90/32	48	<u>3.4</u>	53	<u>3.7</u>	57	<u>4.0</u>
PSIG <u>kg/cm²G</u>	100/38	49	<u>3.5</u>	54	<u>3.8</u>	61	<u>4.3</u>
TOTAL HEAT OF REJECTION FROM CONDENSER	29,100 BTU/h [AT 90°F (32°C) / WT 70°F (21°C)]						
CONDENSER VOLUME	226 CU. IN (SRK-14J3)						

Note: We reserve the right to make changes in specifications and design without prior notice.

B. Condensing Unit

1. SRK-14J

AC SUPPLY VOLTAGE	208-230/60/1 (3 wire with neutral for 115V) (115VAC Supplied to KMS via Factory Wire Harness)		
AMPERAGE	13.5 A (5 Min. Freeze AT 104°F / WT 80°F)		
MINIMUM CIRCUIT AMPACITY	20 A		
MAXIMUM FUSE SIZE	20 A		
EXTERIOR DIMENSIONS (WxDxH)	50" x 17" x 28" (1270 x 432 x 711 mm)		
DIMENSIONS INCLUDING LEGS (WxDxH)	52-3/8" x 19-1/2" x 43" (1330 x 495 x 1092 mm)		
EXTERIOR FINISH	Galvanized steel		
WEIGHT	Net 230 lb. (104 kg)	Shipping 275 lb. (125 kg)	
CONNECTIONS - ELECTRIC	Main Power Supply: Permanent Connection SRK to KMS: Wire Harness Connection		
- REFRIGERANT	Liquid Line 1 1/16" - 12 UNF Fitting (#10 Parker) Suction Line 1 1/8" - 12 UNF Fitting (#11 Parker)		
COMPRESSOR	Hermetic, Model CS16K6E-PFV-255		
CONDENSER	Air Cooled, Fin and Tube Type		
COMPRESSOR PROTECTION	Auto-Reset Overload Protector (Internal)		
FAN MOTOR PROTECTION	Thermal Protection		
REFRIGERANT CIRCUIT PROTECTION	Auto-Reset High-Pressure Switch Auto-Reset Discharge Line Thermostat		
REFRIGERANT CONTROL	Headmaster (C.P.R.) (160 PSI)		
REFRIGERANT CHARGE	16 lb. 5 oz. (7400g) (Condensing Unit 15 lb. 14 oz. (7200g)) (Icemaker 0 lb. 7.1 oz. (200g))		
DESIGN PRESSURE	High 467 PSIG, Low 230 PSIG		
OPERATING CONDITIONS	VOLTAGE RANGE	187 - 253VAC	
	AMBIENT TEMP. (Outdoor use)	-20 - 122°F	
ACCESSORIES -SUPPLIED	Leg		2 pcs
	Hex Head Bolt w/Washer	M8x16	8 pcs
	Hex Nut	M8	8 pcs
-REQUIRED	Compatible KMS Icemaker		

Note: We reserve the right to make changes in specifications and design without prior notice.

2. SRK-14J3

AC SUPPLY VOLTAGE	208-230/60/3 (115VAC Supplied to KMS via Factory Wire Harness)		
AMPERAGE	11.5 A (5 Min. Freeze AT 104°F / WT 80°F)		
MINIMUM CIRCUIT AMPACITY	20 A		
MAXIMUM FUSE SIZE	20 A		
EXTERIOR DIMENSIONS (WxDxH)	50" x 17" x 28" (1270 x 432 x 711 mm)		
DIMENSIONS INCLUDING LEGS (WxDxH)	52-3/8" x 19-1/2" x 43" (1330 x 495 x 1092 mm)		
EXTERIOR FINISH	Galvanized steel		
WEIGHT	Net 230 lb. (104 kg)	Shipping 275 lb. (125 kg)	
CONNECTIONS - ELECTRIC	Main Power Supply: Permanent Connection SRK to KMS: Wire Harness Connection		
- REFRIGERANT	Liquid Line 1 1/16 - 12 UNF FITTING (#10 PARKER) Suction Line 1 1/8 - 12 UNF FITTING (#11 PARKER)		
COMPRESSOR	Hermetic, Model CS16K6E-TF5-255		
CONDENSER	Air Cooled, Fin and Tube Type		
COMPRESSOR PROTECTION	Auto-Reset Overload Protector (Internal)		
FAN MOTOR PROTECTION	Thermal Protection		
REFRIGERANT CIRCUIT PROTECTION	Auto-Reset High-Pressure Switch Auto-Reset Discharge Line Thermostat		
REFRIGERANT CONTROL	Headmaster (C.P.R.) (160 PSI)		
REFRIGERANT CHARGE	16 lb. 5 oz. (7400g) (Condensing Unit 15 lb. 14 oz. (7200g)) (Icemaker 0 lb. 7.1 oz. (200g))		
DESIGN PRESSURE	High 467 PSIG, Low 230 PSIG		
OPERATING CONDITIONS	VOLTAGE RANGE	187 - 253VAC	
	AMBIENT TEMP. (Outdoor use)	-20 - 122°F	
ACCESSORIES -SUPPLIED	Leg		2 pcs
	Hex Head Bolt w/Washer	M8x16	8 pcs
	Hex Nut	M8	8 pcs
-REQUIRED	Compatible KMS Icemaker		

Note: We reserve the right to make changes in specifications and design without prior notice.

II. General Information

A. Construction

1. Icemaker

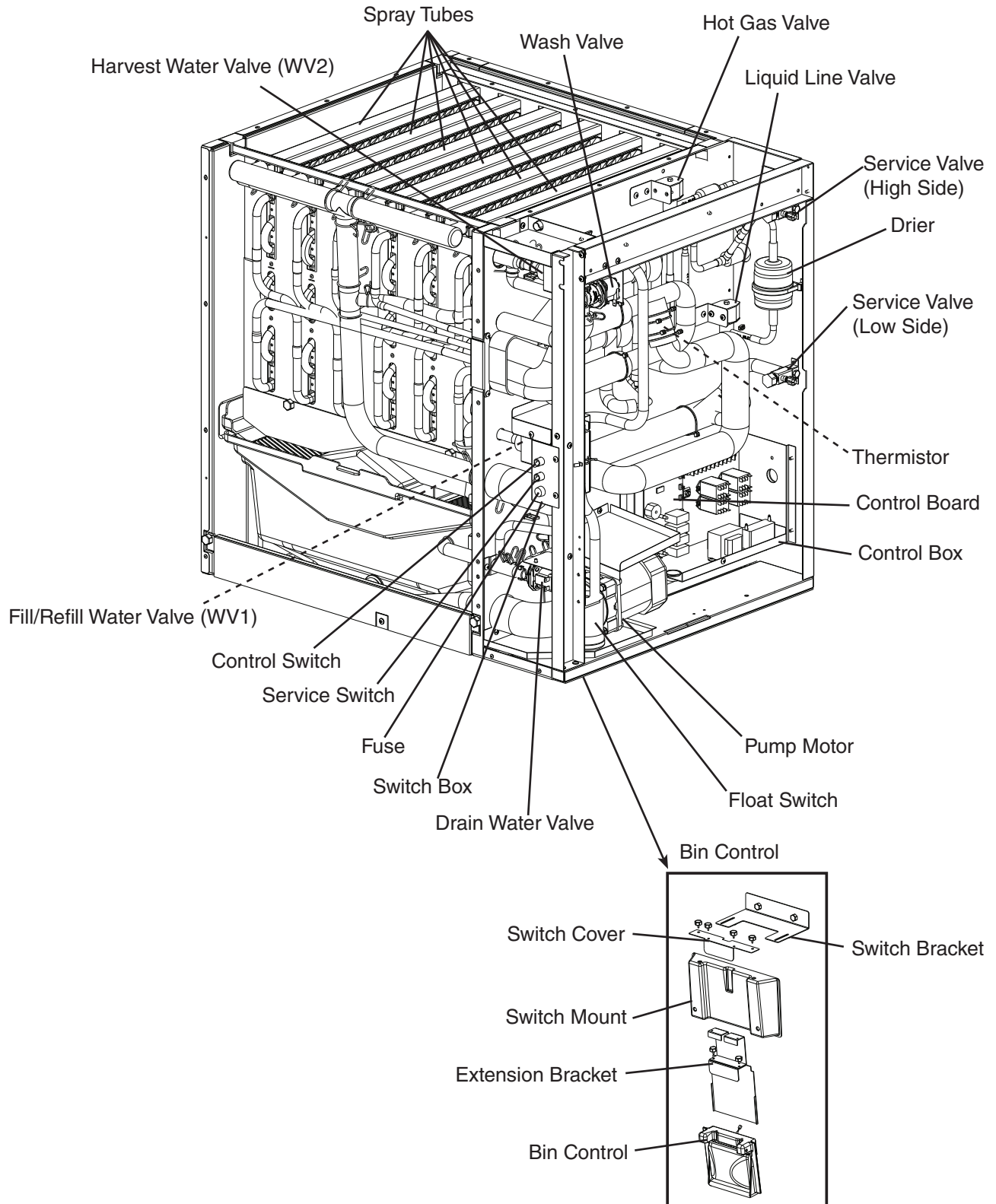

2. Condensing Unit

SRK-14J Control Box

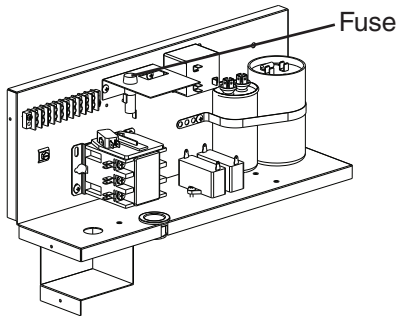

SRK-14J3 Control Box

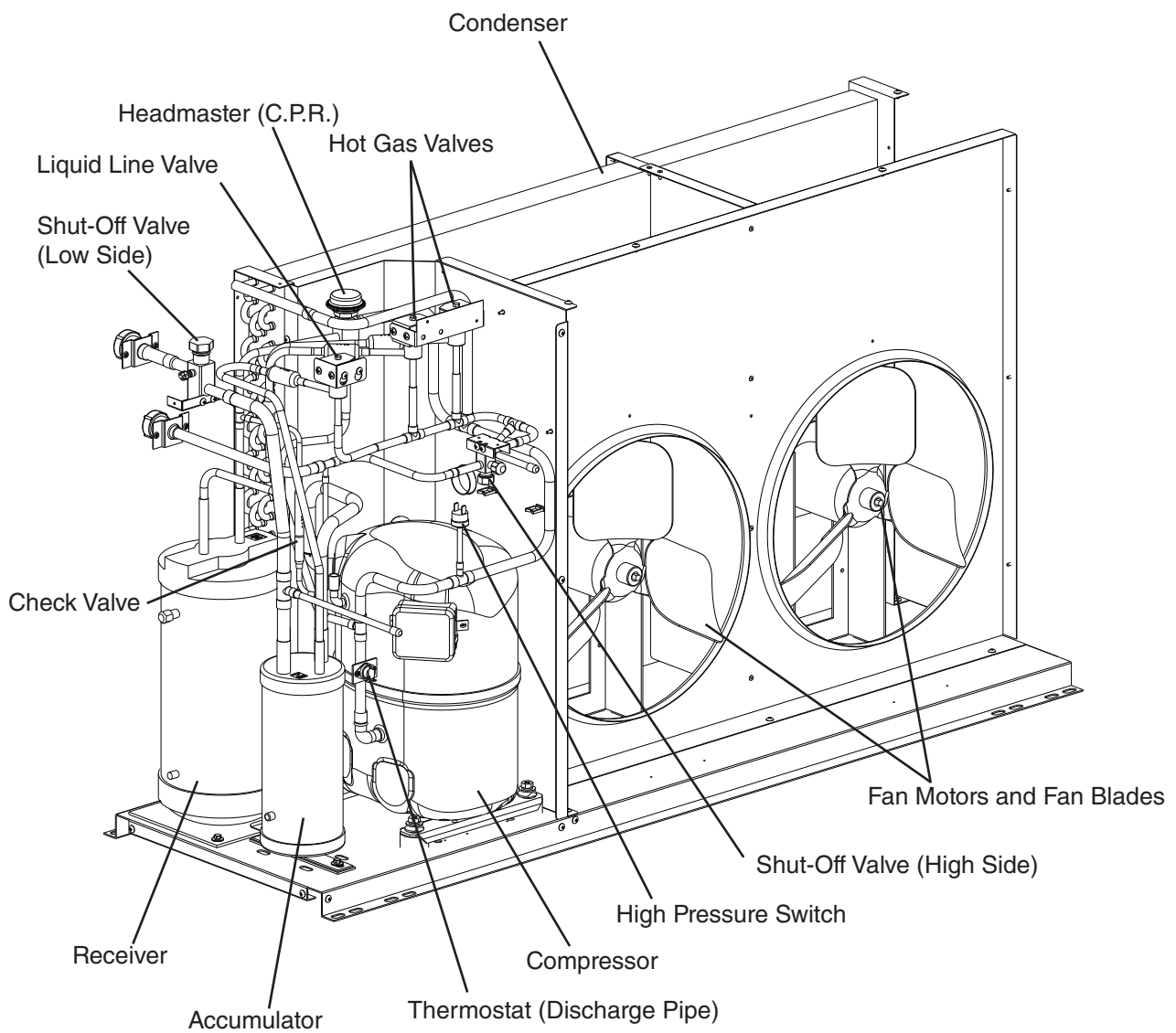
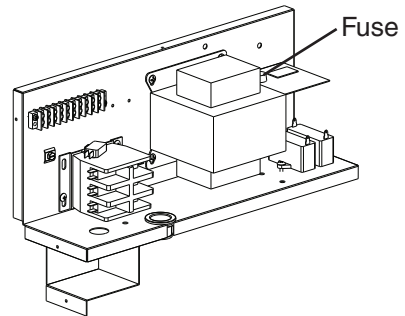

B. Sequence of Operation

1. Sequence Cycles and Shutdown

The steps in the sequence are as outlined below. When power is supplied, the red "POWER OK" LED and the green "BC CLOSED" LED on the CB turn on (If yellow "BC OPEN" LED is on, the icemaker will not start. In this case clear ice away from BC actuator paddle in the storage bin area). A 5-second delay occurs at startup. Note that the order of the green sequence LEDs from the outer edge of the board is 1, 4, 3, 2.

a) 1-Minute Fill Cycle

LED 4 is on. WV1 opens and the fill period begins. After 1-minute, CB checks for closed F/S. If F/S is closed, the harvest cycle begins. If not, WV1 will remain energized through additional 1-minute cycles until water enters the water tank and F/S closes. This serves as a low water safety to protect the water pump.

b) Initial Harvest Cycle

LEDs 1, 4 and 2 are on. Comp, FMRs, HGVs, X10 relay, WV2, X12 relay, and X13 relay energize. WV1 de-energizes. CB monitors the warming of the evaporator via the thermistor located on the suction line. When the thermistor reaches 48°F (9°C), CB reads 3.9 kΩ from the thermistor and turns harvest termination over to the adjustable harvest timer (S4 dip switch 1 & 2). The harvest timer has settings of 60, 90, 120, and 180 seconds. The pump-out timer (S4 dip switch 3 & 4) acts in place of the harvest timer during cycles with a pump-out (S4 dip switch 5 & 6). WV2 and X12 relay are energized during harvest for a maximum of 6 minutes or the length of harvest minus 50 seconds, whichever is shorter. 50 seconds before the harvest timer terminates, harvest pump timer starts. LED 4 turns off, WV2 and X12 relay de-energize.

Harvest Pump Timer: LEDs 1, 3, and 2 are on. Comp, FMRs, HGVs, X10 relay, and X13 relay continue. LED 4 turns off, WV2 and X12 relay de-energize. LED 3 turns on and X11 relay energizes, allowing PM to energize for the last 50 seconds of harvest. **NOTICE! S4 dip switch 7 must remain in the factory default position of 7 on. Otherwise, PM will not energize during the last 50 seconds of harvest.** The minimum total time allowed by CB for a complete harvest cycle is 2 minutes. At the end of harvest, CB checks position of F/S and proceeds to the freeze cycle if it is closed or calls for a 1-minute fill if it is open.

c) Freeze Cycle

LED 1 and LED 4 are on. Comp, FMRs, and PM remain energized. LLVs energize. WV1 and LED 4 energize for 1 min. HGVs, X10, X11, and X13 relays de-energize. For the first 5 minutes, CB will not terminate the freeze cycle. At the end of 5 minutes, F/S assumes control of the freeze cycle. As ice builds on the evaporator, the water level in the water tank lowers. Freeze continues until F/S opens, provided the 5-minute minimum freeze timer has terminated.

d) Pump-Out Cycle

LEDs 1, 3, and 2 are on. Comp and FMRs remain energized, HGVs and X10 relay energize. LLVs de-energize. PM stops for 2 seconds, then X11 relay energizes, allowing PM and DV to energize for 10 or 20 seconds (S4 dip switch 3 & 4). Water is removed from the bottom of the water tank and sent down the drain. At the same time, water flows through the small F/S tube to power flush F/S. When the pump-out timer terminates, pump-out is complete.

The 1st pump-out occurs after the 11th freeze cycle, then every 10th cycle thereafter. The pump-out frequency control is factory set, and generally no adjustment is required. However, where water quality is bad and the icemaker needs a pump-out more often, the pump-out frequency can be adjusted. The pump-out frequency control (S4 dip switch 5 & 6) can be set to have a pump-out occur every cycle, or every 2, 5, or 10 cycles. Timing of the first pump-out is dependent on S4 dip switch 5 & 6 settings. See the table below.

S4 Dip Switch Setting		Pump-Out Frequency	1st Pump-Out
No. 5	No. 6		
OFF	OFF	Every cycle	After 2nd freeze cycle
ON	OFF	Every 2 cycles	After 3rd freeze cycle
OFF	ON	Every 5 cycles	After 6th freeze cycle
ON	ON	Every 10 cycles	After 11th freeze cycle

e) Harvest Cycle

LEDs 1, 4, and 2 are on. Same as the initial harvest cycle. See "II.B.1.b) Initial Harvest Cycle."

Note: Icemaker continues to cycle until BC is satisfied or power is turned off. The icemaker always restarts at the 1-minute fill cycle.

f) Shutdown

When BC is activated (BC open), the yellow "BC OPEN" LED comes on. The icemaker then shuts down as outlined in the table below.

Cycle at Bin Control Activation	Shutdown
Fill Cycle	15 seconds after activation.
Harvest Cycle	At the end of the harvest cycle, or up to 15 seconds into the freeze cycle if activated at the end of the harvest cycle.
Freeze Cycle	15 seconds after activation if activated at least 15 seconds before the 5-minute short cycle protection timer terminates. Otherwise, at the end of the next harvest cycle.

Legend: **CB**—control board; **Comp**—compressor; **DV**—drain valve; **FMRs**—fan motors-remote; **F/S**—float switch; **HGVs**—hot gas valves; **LLVs**—liquid line valves; **PM**—pump motor; **WV1**—fill/refill water valve; **WV2**—harvest water valve

2. Sequence Flow Chart

"G" Control Board Sequence Flow Chart KMS-1401MLJ with SRK-14J/3

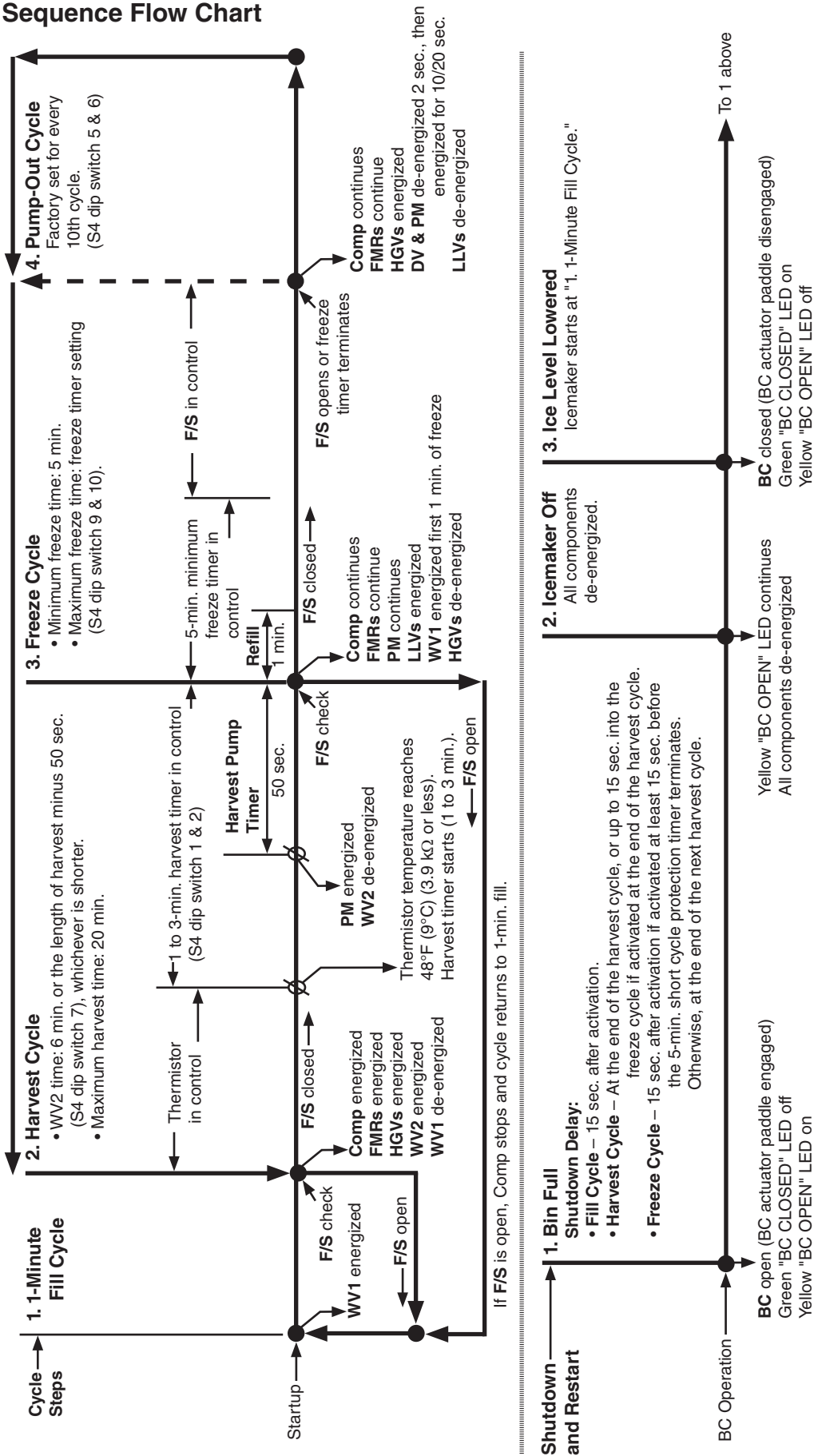

Legend:

- Comp-compressor
- DV-drain valve
- FMRs-fan motors-remote
- F/S-float switch
- HGVs-hot gas valves (KMS and SRK)
- LLVs-liquid line valves (KMS and SRK)
- PM-pump motor
- WV1-fill/refill water valve
- WV2-harvest water valve

Components Energized when the Control Switch is in the "SERVICE" Position

When in the "SERVICE" position, the control switch supplies power to the service switch and the icemaker is in service mode. The service switch has three positions: "DRAIN," "CIRC." and "WASH." See the information below for details of each function.

Position	Power is supplied to the pump and drain valve. This drains the water tank.
DRAIN	Power is supplied to the pump only. This operation can be used to circulate cleaner and sanitizer over the outside surface of the evaporator for extended periods of time.
CIRC.	Power is supplied to the pump and wash valve. This operation is used to circulate cleaner and sanitizer over both the inside and outside surfaces of the evaporator.
WASH	

C. Control Board

- A Hoshizaki exclusive control board is employed in the Hoshizaki icemakers.
- All models are pretested and factory adjusted.
- For a control board check procedure, see "IV.B. Control Board Check."

NOTICE

- Fragile, handle very carefully.
- The control board contains integrated circuits, which are susceptible to failure due to static discharge. It is especially important to touch the metal part of the icemaker when handling or replacing the control board.
- Do not touch the electronic devices on the control board or the back of the control board.
- Do not change wiring and connections. Do not misconnect terminals.
- Do not short out power supply to test for voltage.
- Always replace the whole control board assembly if it goes bad.

1. Control Board Layout

"G" Control Board

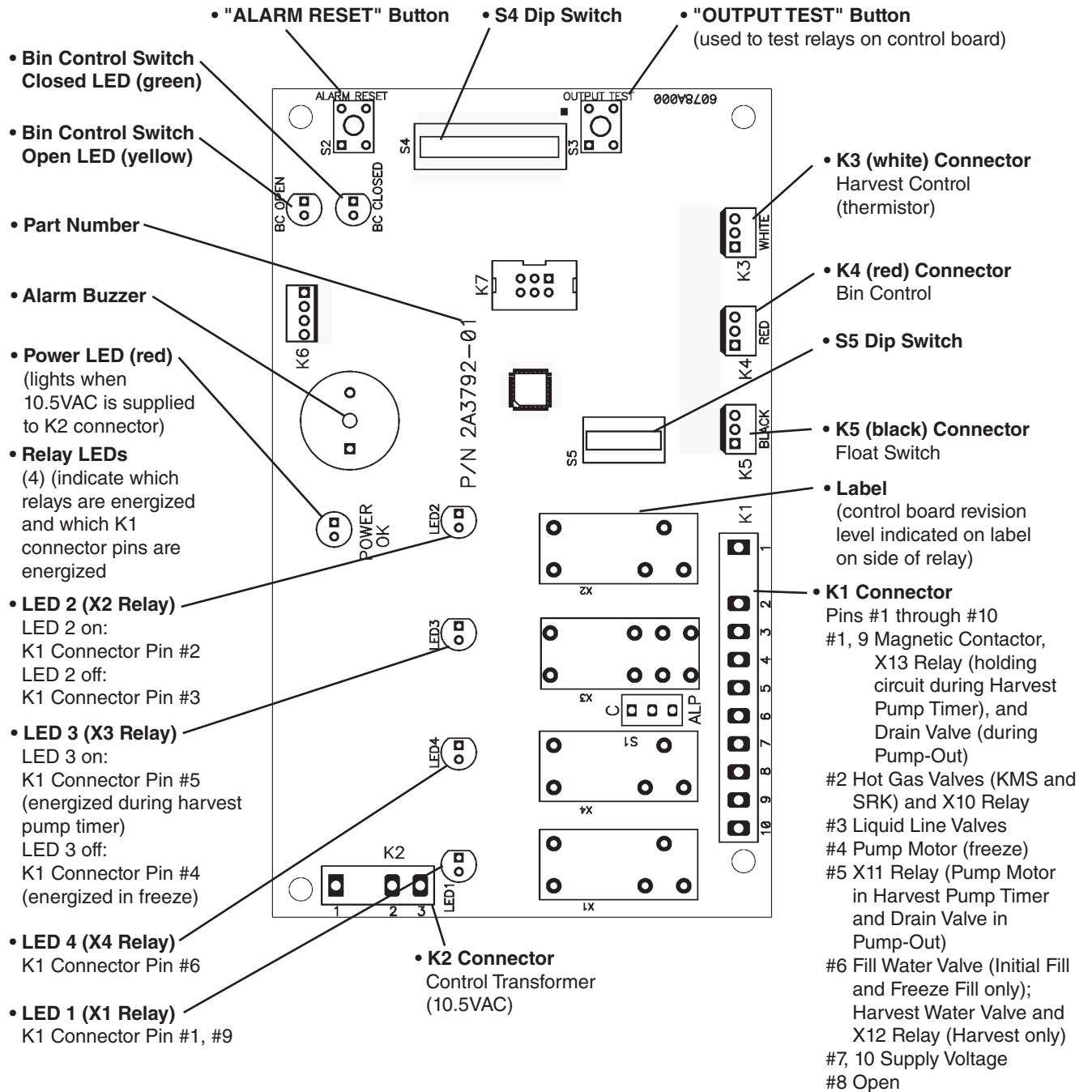

"G" Control Board	
Part Number	2A3792-01

2. LED Lights and Audible Alarm Safeties

At startup, a 5-second delay occurs while the control board conducts an internal timer check. A beep occurs when the control switch is moved to the "ICE" position. The red LED indicates proper control voltage and remains on unless a control voltage problem occurs. The green LEDs 1 through 4 energize and sequence from initial startup as listed in the table below. Note that the order of the LEDs from the outer edge of the control board is 1, 4, 3, 2. For details, see "II.B. Sequence of Operation."

Sequence Step	LED	Energized Components	Time LEDs are On		
			Min.	Max.	Avg.
1-Minute Fill Cycle	4	WV1			1 minute
Harvest Cycle	1, 4, 2	Comp, FMRs WV2, HGVs	2 minutes	20 minutes	3 to 5 minutes
Harvest Pump Timer	1, 3, 2	Comp, FMRs, PM, HGVs	0 seconds	50 seconds	harvest pump timer setting
Freeze Cycle	1 (and 4 for first 1 min.)	Comp, FMRs, PM, LLVs (WV1 for first 1 min.)	5 minutes	freeze timer setting	30 to 35 minutes
Pump-Out Cycle	1, 3, 2	Comp, FMRs, PM, HGVs, DV	10 seconds	20 seconds	

The built in safeties shut down the icemaker and have alarms as listed below.

No. of Beeps (every 3 sec.)	Type of Alarm	Notes
1	High Evaporator Temp. (temperature > 127°F (53°C))	Check for harvest problem (stuck HGVs or relay), hot water entering icemaker, stuck HM, or shorted thermistor.
2	Harvest Backup Timer (harvest > 20 min. for two cycles in a row)	Check for open thermistor, HGVs not opening, TXVs or LLVs leaking by, low charge, or inefficient Comp.
3	Freeze Timer (freeze > specified setting for two cycles in a row) Timer is factory set using S4 dip switch 9 & 10	Check for a F/S stuck closed (up), WV1 or WV2 leaking by, HGVs leaking by, PM not pumping, TXVs not feeding properly, LLVs not opening, low charge, HM not bypassing, or inefficient compressor.
To reset the above safeties, press the "ALARM RESET" button with the power supply on.		
6	Low Voltage (92Vac±5% or less)	Red LED will turn off if voltage protection operates. The control voltage safeties automatically reset when voltage is corrected.
7	High Voltage (147Vac±5% or more)	

Legend: **Comp**—compressor; **DV**—drain valve; **FMRs**—fan motors-remote; **F/S**—float switch; **HGVs**—hot gas valves; **HM**—headmaster (C.P.R.); **LLVs**—liquid line valves; **PM**—pump motor; **TXVs**—thermostatic expansion valves; **WV1**—fill/refill water valve; **WV2**—harvest water valve

3. Controls and Adjustments

NOTICE

Dip switches are factory set. Failure to maintain factory settings may adversely affect performance and warranty coverage. For more information, contact Hoshizaki Technical Support at 1-800-233-1940.

a) **Default Dip Switch Settings**

The dip switches are factory-adjusted to the following positions:

S4 Dip Switch										
Dip Switch No.	1	2	3	4	5	6	7	8	9	10
KMS-1401MLJ/3	OFF	OFF	OFF	ON	ON	ON	ON	OFF	OFF	OFF

S5 Dip Switch (Do Not Adjust)					
Dip Switch No.	1	2	3	4	5
KMS-1401MLJ/3	ON	ON	OFF	OFF	OFF

S4 Dip Switch

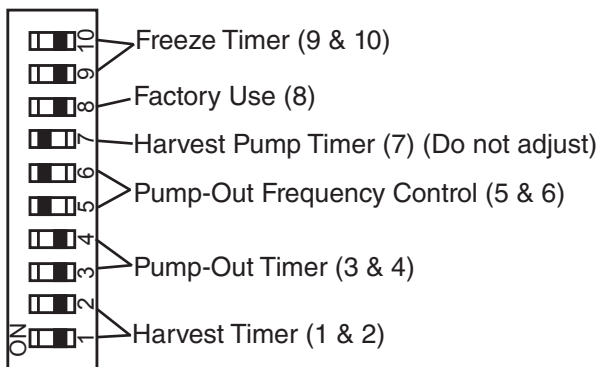

S5 Dip Switch

Do Not Adjust

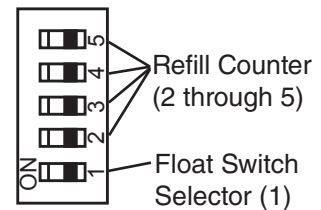

b) **Harvest Timer (S4 dip switch 1 & 2)**

The harvest timer starts counting when the thermistor reads 48°F (9°C) at the evaporator outlet and the control board reads the thermistor's 3.9 kΩ signal. The harvest timer is factory set, and generally no adjustment is required. However, a setting longer than the factory setting may be advised in cases where the flush provided at harvest needs to be prolonged for extra cleaning. Before changing this setting, contact Hoshizaki Technical Support at 1-800-233-1940 for recommendations. Keep in mind that setting the harvest timer to a longer setting decreases 24-hour production.

Note that the pump-out timer (S4 dip switch 3 & 4) acts in place of the harvest timer during cycles with a pump-out. For details, see "II.C.3.c) Pump-Out Timer (S4 dip switch 3 & 4)."

Dip Switch Setting		Time (seconds)
No. 1	No. 2	
OFF	OFF	60
ON	OFF	90
OFF	ON	120
ON	ON	180

c) Pump-Out Timer (S4 dip switch 3 & 4)

The 1st pump-out occurs after the 11th freeze cycle, then every 10th cycle thereafter. When a pump-out is called for, the X10 relay is energized and the X13 relay is de-energized to allow the drain valve to energize. The pump motor stops for 2 seconds, then the X11 relay energizes, allowing the pump motor and drain valve to energize. Water is removed from the bottom of the water tank and sent down the drain. At the same time, water flows through the small float switch tube to power flush the float switch. The pump-out drains the water tank for the time determined by the pump-out timer. The pump-out timer also acts in place of the harvest timer during cycles with a pump-out. The pump-out timer is factory set, and generally no adjustment is required. The pump-out timer control can be set to pump-out for 10 or 20 seconds.

S4 Dip Switch Setting		Time (seconds)		Inlet Water Valve
No. 3	No. 4	T1	T2	
OFF	OFF	10	150	closed
ON	OFF	10	180	closed
OFF	ON	10	120	open if refill = 0; closed if refill 1 or greater
ON	ON	20	180	closed

T1: Time to drain the water tank

T2: Harvest timer at pump-out

d) Pump-Out Frequency Control (S4 dip switch 5 & 6)

The pump-out frequency control is factory-adjusted to drain the water tank every 10 cycles, and generally no adjustment is required. However, where water quality is bad and the icemaker needs a more frequent pump-out, the pump-out frequency can be adjusted as shown in the table below.

Timing of the first pump-out is dependent on S4 dip switch 5 & 6 settings. See the table below.

S4 Dip Switch Setting		Pump-Out Frequency	1st Pump-Out
No. 5	No. 6		
OFF	OFF	Every cycle	After 2nd freeze cycle
ON	OFF	Every 2 cycles	After 3rd freeze cycle
OFF	ON	Every 5 cycles	After 6th freeze cycle
ON	ON	Every 10 cycles	After 11th freeze cycle

e) Harvest Pump Timer (S4 dip switch 7)

NOTICE	
Factory set for proper operation. Do not adjust. Adjustment outside of the factory default setting may result in damage to the icemaker.	

Depending on the harvest pump timer setting, the pump motor either stays off or is energized the last 50 seconds of harvest. When the pump motor is energized, water circulates over the evaporator. The harvest water valve is open during harvest for a maximum of 6 minutes or the length of harvest minus 0 or 50 seconds (determined by the harvest pump timer setting), whichever is shorter.

When S4 dip switch 7 is in the on position and harvest begins, X10 relay energizes and allows the harvest water valve, X12, and X13 relays to energize. A lockout circuit is created using the X10, X12, and X13 relays. This prevents the drain valve from energizing during harvest pump timer. See "III.B. Wiring Diagram."

50 seconds before harvest termination, LED 4 goes off de-energizing WV2 (harvest water valve) and X12 relay. X13 relay remains energized through the holding circuit through X10 and X13 relays. Next, LED 3 on the control board turns on and X11 relay energizes, allowing the pump motor to energize. The pump motor is energized the last 50 seconds of harvest.

S4 Dip Switch Setting		Pump Motor Time (seconds)
No. 7		
	ON	50
	OFF	0

f) Factory Use (S4 dip switch 8)

Factory set for proper operation. Do not adjust. This must be left in the factory default position.

g) Freeze Timer (S4 dip switch 9 & 10)

NOTICE	
Adjust to proper specification, or the icemaker may not operate correctly.	

The freeze timer setting determines the maximum allowed freeze time to prevent possible freeze-up issues. Upon termination of freeze timer, the control board initiates the harvest cycle. After 2 consecutive freeze timer terminations, the control board shuts down the icemaker. In this case, see "IV.F.3. Low Ice Production" for possible solutions.

The freeze timer is factory set, and generally no adjustment is required. Before changing this setting, contact your local Hoshizaki distributor or Hoshizaki Technical Support for recommendations.

Dip Switch Setting		Time (minutes)
No. 9	No. 10	
OFF	OFF	60
OFF	ON	50
ON	OFF	70
ON	ON	60

h) Float Switch Selector (S5 dip switch 1)

NOTICE
Do not adjust. This must be left in the factory default position or the icemaker will not operate correctly.

On icemakers with a double float switch, the float switch selector determines which float switch (upper or lower) the control board monitors for refill initiation during the freeze cycle, and the refill counter (S5 dip switch 2 through 5) determines the number of refills. The KMS-1401MLJ uses a single float switch with a double float switch, upper float switch refill initiation float switch selector setting and is set for 1 refill. When the freeze cycle starts, the control board monitors the upper float switch. If an upper float switch exists, refill is initiated by an open upper float switch and is terminated by a closed upper float switch. There is a maximum refill time of 1 minute. In a single float switch application with a double float switch setting, no upper float switch exists, therefore the control board reads an open upper float switch immediately when the freeze cycle starts and initiates a refill. Since there is no upper float switch to close and terminate the refill, the refill lasts for the maximum 1-minute. During the 1-minute refill, LED 4 is on.

S5 Dip Switch Setting	Float Switch Type	Refill Initiation with Double Float Switch
No. 1		
OFF	Single or Double	Lower Float Switch
ON	Double	Upper Float Switch

i) Refill Counter (S5 dip switch 2 through 5)

NOTICE
Do not adjust. These must be left in the factory default position or the icemaker will not operate correctly.

Factory set. S5 dip switch 2 through 5 allows for refills during the freeze cycle. The KMS-1401MLJ is factory set for 1 refill. Do not adjust.

S5 Dip Switch Setting				No. of Refills
No. 2	No. 3	No.4	No. 5	
ON	OFF	OFF	OFF	1 Refill

Note: When refill set > 0, water valve is off during pump-out even if S4 dip switch 3 & 4 are set to 3 off and 4 on. See "II.C.3.c) Pump-Out Timer (S4 dip switch 3 & 4)."

D. Control and Service Switches

2 switches are used to control the operation of the icemaker. These switches are referred to as control switch and service switch. They are located on the KMS switch box.

1. Control Switch

The control switch has three positions: "OFF" for power off; "ICE" for icemaking, and "SERVICE" to activate the service switch.

2. Service Switch

When the control switch is in the "SERVICE" position, the control switch supplies power to the service switch and water pump. The service switch has three positions: "DRAIN," "CIRC." and "WASH."

Note:

1. When the service switch is active (control switch in the "SERVICE" position), power is supplied to the water pump in all three positions.
2. When the control switch is in the "OFF" or "ICE" position, the service switch is de-activated. In this state, it can be left in any position.

a) DRAIN

This icemaker utilizes a pump-out drain system. When the control switch is in the "SERVICE" position and the service switch is placed in the "DRAIN" position, power is supplied to the water pump and drain valve.

b) CIRC.

When the service switch is active and placed in the "CIRC." position, power is supplied to the water pump only. This water pump operation is used during cleaning to circulate cleaner for extended periods of time over the outside surface of the evaporator.

c) WASH

This icemaker utilizes a solenoid operated wash (bypass) valve. When the service switch is active and placed in the "WASH" position, power is supplied to the pump motor and wash valve. This operation is used to circulate cleaner and sanitizer over both the inside and outside of the evaporator.

III. Technical Information

A. Water Circuit and Refrigeration Circuit

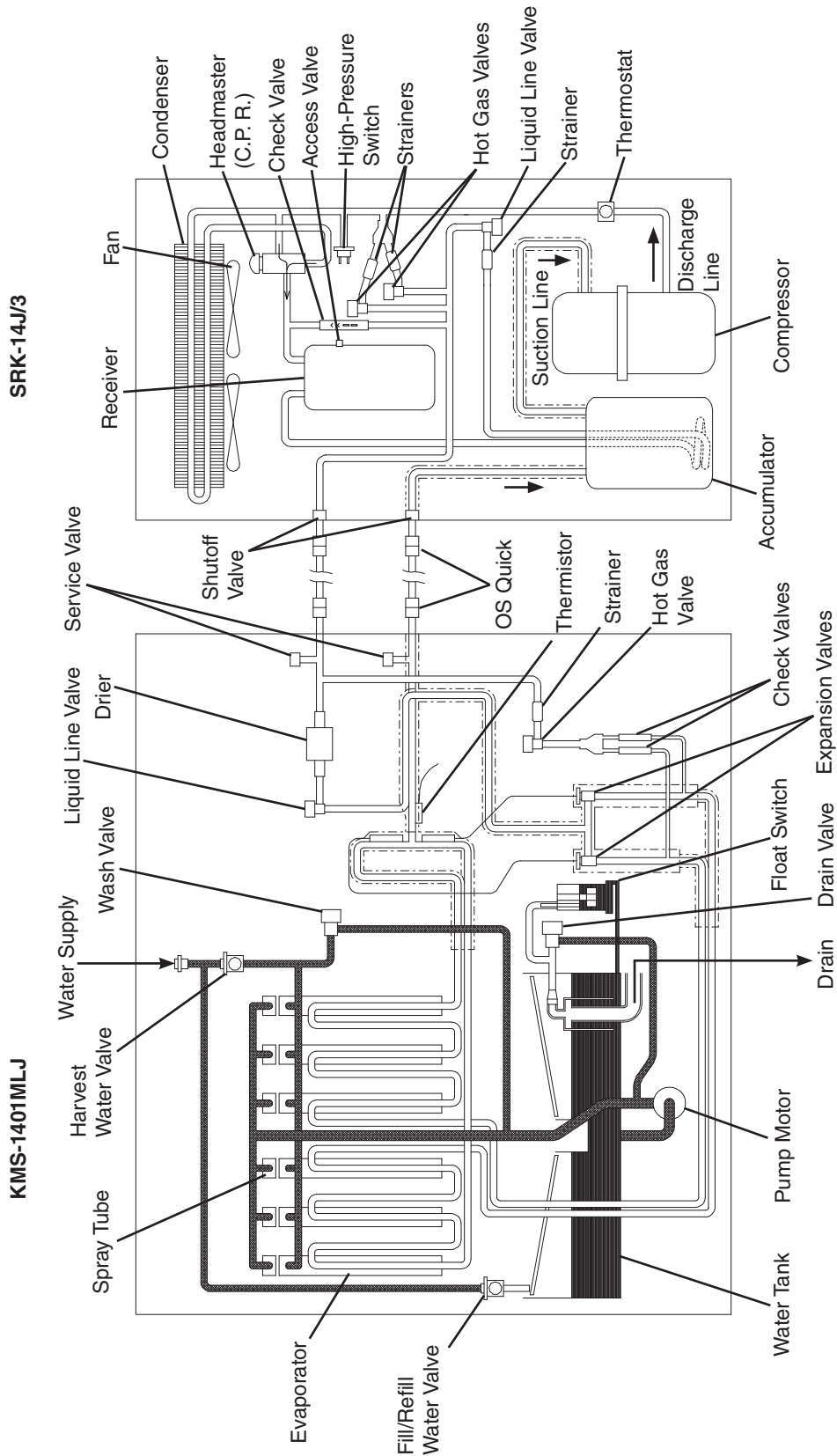

2. KMS-1401MLJ with SRK-14J3

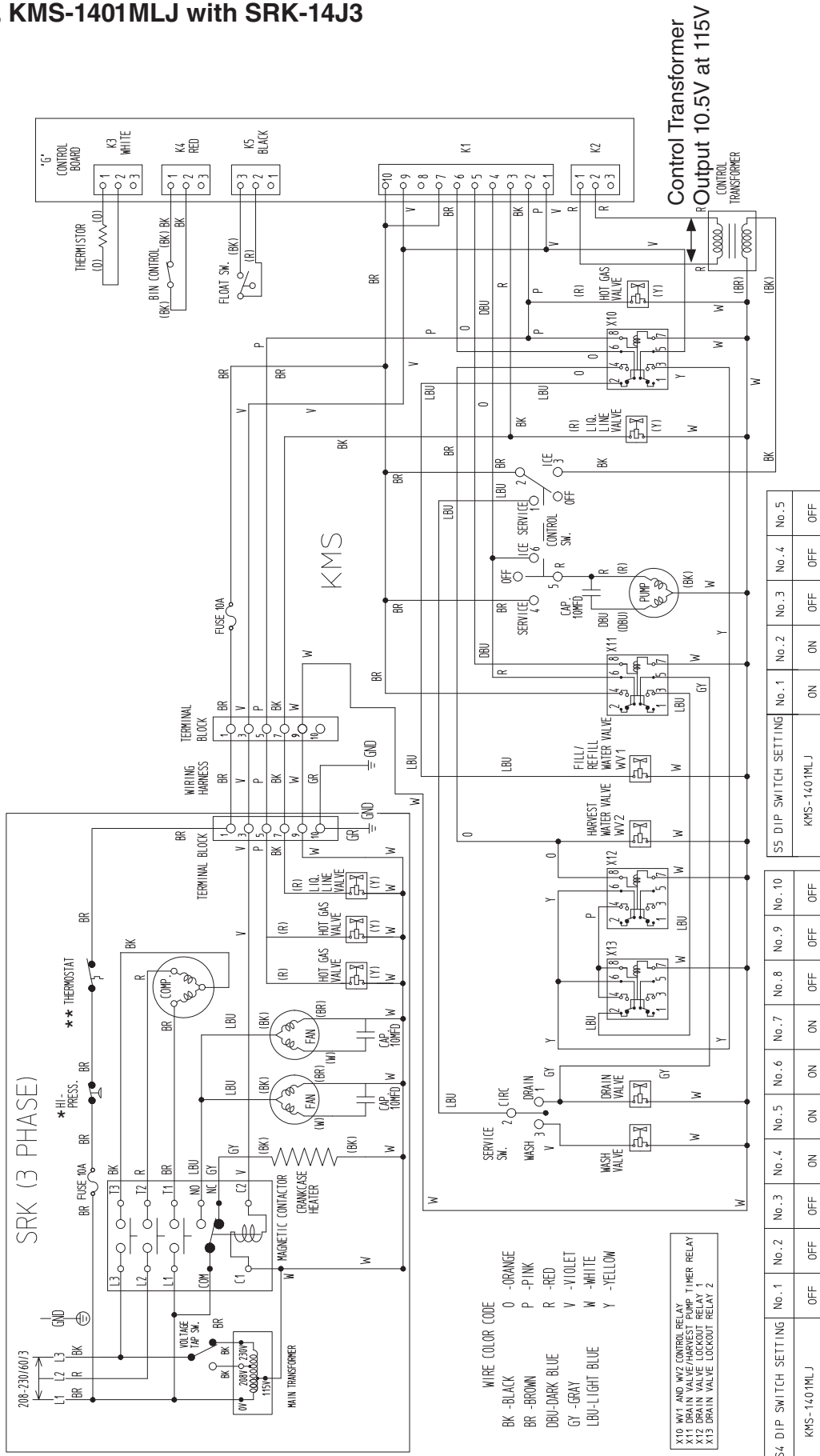

**** Thermostat Switch**

Cut-out	266°F±9°F (130°C±5°C)
Cut-in	239°F±9°F (115°C±5°C)

*** High-Pressure Switch**

Cut-out	426±22 PSIG
Cut-in	341±22 PSIG

3. Wire Harness Connections

Wire Harness Connections

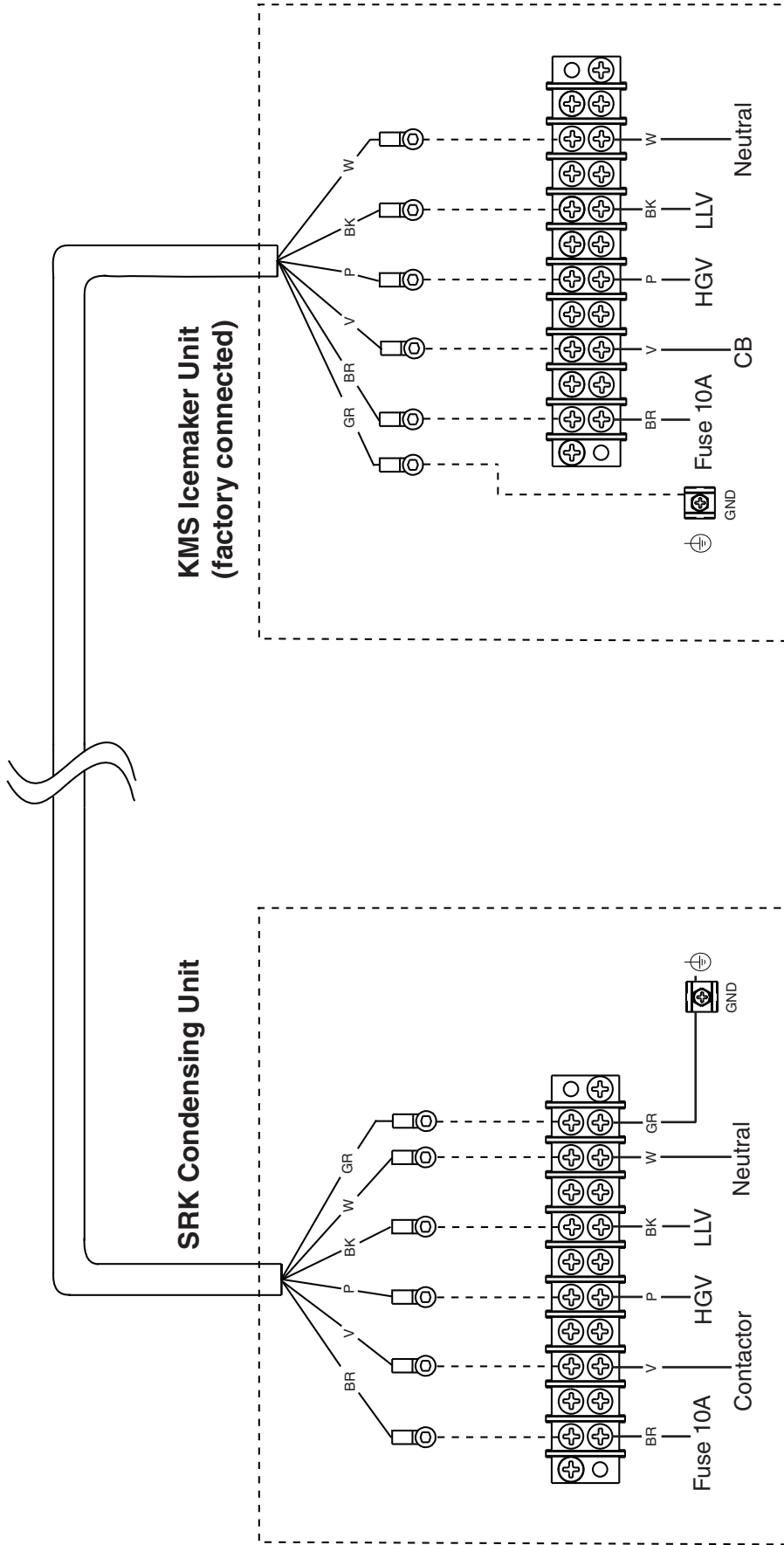

Legend:
 GND-ground
 HGV-hot gas valve
 CB-control board
 LLV-liquid line valve
 L2-single phase power supply
 L3-three phase power supply

Wire Color Code:
 BK-black
 BR-brown
 GR-green
 P-pink
 V-violet
 W-white

C. Performance Data

1. KMS-1401MLJ with SRK-14J

APPROXIMATE ICE PRODUCTION PER 24 HR.	AMBIENT TEMP. (°F/°C)	WATER TEMP. (°F/°C)					
		50/10		70/21		90/32	
	70/21	1420	<u>644</u>	1379	<u>626</u>	1278	<u>580</u>
	80/27	1389	<u>630</u>	1325	<u>601</u>	1199	<u>544</u>
	90/32	1379	<u>626</u>	1280	<u>581</u>	1162	<u>527</u>
lbs./day <u>kg./day</u>	100/38	1344	<u>609</u>	1252	<u>568</u>	1054	<u>478</u>
APPROXIMATE ELECTRIC CONSUMPTION	70/21	2410		2439		2492	
	80/27	2432		2478		2537	
	90/32	2439		2510		2567	
watts	100/38	2454		2523		2620	
APPROXIMATE WATER CONSUMPTION PER 24 HR.	70/21	682	<u>2.58</u>	555	<u>2.10</u>	492	<u>1.86</u>
	80/27	585	<u>2.22</u>	388	<u>1.47</u>	386	<u>1.46</u>
	90/32	555	<u>2.10</u>	250	<u>0.94</u>	220	<u>0.83</u>
gal./day <u>m³/day</u>	100/38	411	<u>1.56</u>	243	<u>0.92</u>	193	<u>0.73</u>
FREEZING CYCLE TIME	70/21	24		25		27	
	80/27	25		26		29	
	90/32	25		27		30	
min.	100/38	26		28		33	
HARVEST CYCLE TIME	70/21	4.6		3.9		3.6	
	80/27	4.0		3.0		3.1	
	90/32	3.9		2.2		2.2	
min.	100/38	3.1		2.2		2.1	
HEAD PRESSURE	70/21	178	<u>12.5</u>	197	<u>13.8</u>	219	<u>15.4</u>
	80/27	192	<u>13.5</u>	221	<u>15.6</u>	241	<u>17.0</u>
	90/32	197	<u>13.8</u>	242	<u>17.0</u>	263	<u>18.5</u>
PSIG <u>kg/cm²G</u>	100/38	200	<u>14.1</u>	247	<u>17.4</u>	283	<u>19.9</u>
SUCTION PRESSURE	70/21	46	<u>3.2</u>	47	<u>3.3</u>	50	<u>3.5</u>
	80/27	47	<u>3.3</u>	49	<u>3.5</u>	52	<u>3.7</u>
	90/32	47	<u>3.3</u>	51	<u>3.6</u>	54	<u>3.8</u>
PSIG <u>kg/cm²G</u>	100/38	48	<u>3.4</u>	52	<u>3.6</u>	56	<u>3.9</u>

TOTAL HEAT OF REJECTION FROM CONDENSER 28,800 BTU/h [AT 90°F (32°C) / WT 70°F (21°C)]

CONDENSER VOLUME 226 CU. IN (SRK-14J)

Note:

1. Pressure data is recorded at 5 minutes into freezing cycle. The data not in bold should be used for reference only.
2. We reserve the right to make changes in specifications and design without prior notice.

2. KMS-1401MLJ with SRK-14J3

APPROXIMATE ICE PRODUCTION PER 24 HR.	AMBIENT TEMP. (°F/°C)	WATER TEMP. (°F/°C)					
		50/10		70/21		90/32	
	70/21	1400	<u>635</u>	1365	<u>619</u>	1266	<u>574</u>
	80/27	1373	<u>623</u>	1319	<u>598</u>	1191	<u>540</u>
	90/32	1365	<u>619</u>	1280	<u>581</u>	1163	<u>527</u>
lbs./day <u>kg./day</u>	100/38	1328	<u>602</u>	1253	<u>568</u>	1055	<u>479</u>
APPROXIMATE ELECTRIC CONSUMPTION	70/21	2470		2482		2528	
	80/27	2479		2497		2561	
	90/32	2482		2510		2567	
watts	100/38	2501		2523		2620	
APPROXIMATE WATER CONSUMPTION PER 24 HR.	70/21	757	<u>2.87</u>	611	<u>2.31</u>	534	<u>2.02</u>
	80/27	645	<u>2.44</u>	417	<u>1.58</u>	410	<u>1.55</u>
	90/32	611	<u>2.31</u>	256	<u>0.97</u>	218	<u>0.82</u>
gal./day <u>m³/day</u>	100/38	442	<u>1.67</u>	247	<u>0.94</u>	183	<u>0.69</u>
FREEZING CYCLE TIME	70/21	24		25		28	
	80/27	25		27		30	
	90/32	25		28		31	
min.	100/38	26		29		33	
HARVEST CYCLE TIME	70/21	5.3		4.4		4.1	
	80/27	4.6		3.3		3.4	
	90/32	4.4		2.3		2.2	
min.	100/38	3.5		2.3		2.1	
HEAD PRESSURE	70/21	175	<u>12.3</u>	197	<u>13.8</u>	221	<u>15.5</u>
	80/27	192	<u>13.5</u>	226	<u>15.9</u>	246	<u>17.3</u>
	90/32	197	<u>13.8</u>	250	<u>17.6</u>	272	<u>19.2</u>
PSIG <u>kg/cm²G</u>	100/38	200	<u>14.0</u>	255	<u>17.9</u>	293	<u>20.6</u>
SUCTION PRESSURE	70/21	46	<u>3.2</u>	48	<u>3.4</u>	52	<u>3.6</u>
	80/27	48	<u>3.3</u>	51	<u>3.6</u>	55	<u>3.9</u>
	90/32	48	<u>3.4</u>	53	<u>3.7</u>	57	<u>4.0</u>
PSIG <u>kg/cm²G</u>	100/38	49	<u>3.5</u>	54	<u>3.8</u>	61	<u>4.3</u>
TOTAL HEAT OF REJECTION FROM CONDENSER				29,100 BTU/h [AT 90°F (32°C) / WT 70°F (21°C)]			
CONDENSER VOLUME				226 CU. IN (SRK-14J3)			

Note:

1. Pressure data is recorded at 5 minutes into freezing cycle. The data not in bold should be used for reference only.
2. We reserve the right to make changes in specifications and design without prior notice.

IV. Service Diagnosis

WARNING

- This icemaker should be diagnosed and repaired only by qualified service personnel to reduce the risk of death, electric shock, serious injury, or fire.
- Risk of electric shock. Use extreme caution and exercise safe electrical practices.
- Moving parts (e.g., fan blade) can crush and cut. Keep hands clear.
- **CHOKING HAZARD:** Ensure all components, fasteners, and thumbscrews are securely in place after the icemaker is serviced. Make sure that none have fallen into the dispenser unit/storage bin.
- Make sure all food zones in the icemaker and dispenser unit/storage bin are clean after service. For cleaning procedures, see "VI. Cleaning and Maintenance."

A. Diagnostic Procedure

The diagnostic procedure is basically a sequence check which can be used at icemaker startup or for system diagnosis. This procedure allows you to diagnose electrical system and component failures. Before conducting the diagnostic procedure, check for correct installation, proper voltage per unit nameplate, and adequate water supply. Check CB using the steps in "IV.B. Control Board Check." Check the dip switch settings to assure that S4 dip switch 3, 4, 7, 8, 9, 10 and S5 dip switch 1 through 5 are in the factory default position. S4 dip switch 1, 2, 5, 6 are cleaning adjustments and the settings are flexible. For factory default settings, see "II.C.3.a) Default Dip Switch Settings." As you go through the procedure, check to assure the components energize and de-energize correctly. If not, those components and controls are suspect.

- 1) Turn off the power supply, then access the control box. Clear any ice from BC.
- 2) Turn on the power supply, then move the control switch to the "ICE" position. A 5-second delay occurs. The red "POWER OK" LED and the green "BC CLOSED" LED on CB come on. If the yellow "BC OPEN" LED is on, check BC. See "IV.C. Bin Control Check and Cleaning."
- 3) **1-Minute Fill Cycle – LED 4 is on.** WV1 energizes. After 1 minute, CB checks for a closed F/S. If F/S is closed, the harvest cycle begins. If closed, continue to step 4. If F/S is open, WV1 remains energized through additional 1-minute fill cycles until water enters the water tank and F/S closes (low water safety protection during initial start up and at the end of each harvest). **Diagnosis:** Confirm that water enters the water tank. If not, check that the water supply shut-off valve is open and screens or external filters are clear. Check supply voltage at WV1 solenoid. If no voltage is present, see "IV.B. Control Board Check." If voltage is present, check solenoid continuity. If the water tank fills, but the icemaker fails to start harvest, check for open F/S. See "IV.D. 1. Float Switch Check." Check termination of 1-minute timer in CB. See "IV.B. Control Board Check."

4) **Initial Harvest Cycle – LEDs 1, 4, and 2 are on.** Comp, FMRs, HGVs, X10 relay, WV2, X12, and X13 relays energize. WV1 de-energizes. CB monitors the warming of the evaporator via the thermistor located on the suction line. When the thermistor reaches 48°F (9°C), CB reads 3.9 kΩ from the thermistor and turns harvest termination over to the harvest timer (S4 dip switch 1 & 2). The harvest timer has settings of 60, 90, 120, and 180 seconds. The pump-out timer (S4 dip switch 3 & 4) acts in place of the harvest timer during cycles with a pump-out (S4 dip switch 5 & 6). WV2 and X12 relay are energized during harvest for a maximum of 6 minutes or the length of harvest minus 50 seconds, whichever is shorter. 50 seconds before the harvest timer terminates, harvest pump timer starts. LED 4 turns off, WV2 and X12 relay de-energize.

Harvest Pump Timer – LEDs 1, 3, and 2 are on. Comp, FMRs, HGVs, and X10 relay continue. LED 4 turns off, WV2 and X12 relay de-energize (CB K1 connector pin #6 (O wire)). LED 3 turns on and X11 relay energizes (CB K1 connector pin #5 (DBU wire)), allowing PM to energize for the last 50 seconds of harvest (S4 dip switch 7 setting). **NOTICE! S4 dip switch 7 must remain in the factory default position of 7 on. Otherwise, PM will not energize during the last 50 seconds of harvest.** The minimum total time allowed by CB for a complete harvest cycle is 2 minutes. At the end of harvest, CB checks the position of F/S and proceeds to the next cycle if it is closed, or calls for a 1-minute fill cycle if it is open.

Diagnosis: Check that evaporator is warming and Comp, FMRs, and HGVs remain energized. WV2 is energized during harvest for a maximum of 6 minutes or the length of harvest minus 50 seconds (Harvest Pump Timer (S4 dip switch 7)), whichever is shorter. Average initial harvest cycle at factory setting is 2 to 3 minutes. 1.5 minutes after initial harvest begins, touch Comp discharge line. Is it hot? If not, check that Comp is energized, refrigerant pressures are in range, HGVs are energized and open, LLVs are de-energized and closed. If discharge line is hot, place a thermometer on the suction line next to the thermistor. Has it warmed to 48°F (9°C) or warmer? Confirm thermistor status. See "IV.E. Thermistor Check." If temperature has been reached, check that WV2 de-energizes (LED 4 off) and X11 relay energizes (LED 3 on), allowing PM to energize and circulate water over the evaporator for the last 50 seconds of harvest. If not, make sure S4 dip switch 7 is in the factory default position. Check CB K1 connector pin #5 (DBU wire) and X11 relay for 115VAC. If 1-minute fill cycle starts after harvest, see "IV.D. Float Switch Check and Cleaning." If the thermistor reading is in proper range and CB fails to terminate the harvest cycle and initiate the freeze cycle, replace CB.

5) **Freeze Cycle – LED 1 and 4 are on.** Comp, FMRs, and PM remain energized (CB K1 connector pin #5 (DBU wire) de-energizes and K1 connector pin #4 (R wire) energizes to prevent PM interruption). LLVs energize. WV1 and LED 4 energize for 1 min. HGVs, X10, X11, and X13 relays de-energize.

Refill – LEDs 1 and 4 are on. The KMS-1401MLJ uses a single F/S with a double F/S, UF/S refill initiation float switch selector setting (S5 dip switch 1) and is set for 1 refill (S5 dip switch 2 through 5). When the freeze cycle starts, CB monitors UF/S. No UF/S exists on the KMS-1401MLJ, therefore CB reads an open UF/S immediately when the freeze cycle starts and initiates a refill (CB energizes WV1 through X10 relay). Since there is no UF/S to close and terminate the refill, the refill lasts for the maximum 1-minute. During the 1-minute refill, LED 4 is on. Comp, FMRs, LLVs, and PM remain energized.

Freeze Termination – LED 1 is on. The icemaker is held in freeze by a 5-minute short cycle protection timer. When F/S opens, the freeze cycle terminates.

Diagnosis: Minimum freeze time is 5 minutes. During the first 5 minutes of freeze, confirm that Comp, FMRs, PM, and LLVs are energized, WV1 is energized for 1 min., and HGVs and WV2 are de-energized and not bypassing. The evaporator temperature should be dropping. Make sure TXVs and HM are operating properly. Check that DV is not leaking by (water flowing down the potable drain). Check for proper unit pressures (see "III.C. Performance Data") or an inoperative Comp. Disconnect the black K5 F/S connector. When 5 or more minutes have elapsed in the freeze cycle, the icemaker should switch out of the freeze cycle. After the icemaker switches out of freeze, reconnect the black K5 F/S connector to CB. If the icemaker remains in freeze with F/S disconnected, replace CB. To check F/S, see "IV.D. Float Switch Check and Cleaning."

Note: Normal freeze cycle will last 30 to 35 minutes depending on model and conditions. Cycle times and pressures should follow performance data provided in this manual. See "III.C. Performance Data."

6) **Pump-Out Cycle – LEDs 1, 3, and 2 are on (10/20 second pump-out)** – The 1st pump-out occurs after the 11th freeze cycle, then every 10th cycle thereafter. Comp and FMRs remain energized. HGVs and X10 relay energize. LLVs de-energize. PM de-energizes for 2 seconds, then X11 relay energizes, allowing PM and DV to energize for 10 seconds. PM energized through X11 relay (energized) terminal #4 (BR wire) and terminal #6 (R wire), then through control switch terminal #6 (R wire) and terminal #5 (R wire). DV energized through X10 relay (energized) terminal #5 (V wire) and terminal #3 (Y wire), then through X13 relay (de-energized) terminal #6 (Y wire) and terminal #2 (LBU wire), then through X11 relay (energized) terminal #3 (LBU wire) and terminal #5 (GY wire). This pump-out removes contaminants from the water tank through DV and allows for a power flush of F/S. **Diagnosis: PM Operation:** If PM does not come on, check CB K1 connector pin #5 (DBU wire) (X11 relay coil voltage) to a neutral (W wire) for 115VAC. If LED 3 is on and 115VAC is not present, replace CB. If 115VAC is present, X11 relay should energize and X11 terminals #4 (BR wire) and #6 (R wire) should be closed. Check X11 relay terminal #6 (R wire) for 115VAC to a neutral (W wire). If 115VAC is not present, check X11 relay coil and contact continuity. If 115VAC is present and PM is still not energized, check control switch continuity between terminal #5 (R wire) and #6 (R wire). If closed, check PM windings and capacitor. **DV Operation:** If water does not pump out, check CB K1 connector pin #1 (V wire) (power supply for DV operation) and CB K1 connector pin #2 (P wire) (X10 relay coil voltage for DV operation) to a neutral (W wire) for 115VAC. If 115VAC is not present on either circuit, replace CB. If 115VAC is present, X10 relay terminals #1 (Y wire) and #5 (V wire) should be closed. Check X10 relay terminal #3 (Y wire) to a neutral (W wire) for 115VAC. If 115VAC is not present on terminal #3 (Y wire), check X10 relay coil and contact continuity. If 115VAC is present on X10 relay terminal #3 (Y wire), go to X13 relay and check X13 relay terminal #2 (LBU wire) to a neutral (W wire) for 115VAC. If 115VAC is not present, check X13 relay contact continuity between terminal #2 (LBU wire) and terminal #6 (Y wire). If contacts are open, confirm X13 is de-energized. If 115VAC is present, check X11 relay terminal #5 (GY wire) to a neutral (W wire) for 115VAC. If 115VAC is not present, check continuity between X11 relay (energized) terminal #3 (LBU wire) and terminal #5 (GY wire). If 115VAC is present on X11 terminal #5 (GY wire), check continuity on DV coil. Next, remove DV housing and check/clean DV assembly, make sure that the drain line is not clogged.

7) **Normal Harvest Cycle** – Same as the initial harvest cycle. Return to step 4.

Note: Ice maker continues to cycle until BC is satisfied or power is switched off. The ice maker always restarts at the 1-minute fill cycle.

Legend: **CB**–control board; **Comp**–compressor; **DV**–drain valve; **FMRs**–fan motors-remote; **F/S**–float switch; **HGVs**–hot gas valves; **HM**–headmaster (C.P.R.); **LLVs**–liquid line valves; **PM**–pump motor; **TXVs**–thermostatic expansion valves; **UF/S**–upper float switch; **WV1**–fill/refill water valve; **WV2**–harvest water valve; **X10**–WV1 and WV2 control relay; **X11**–drain valve/harvest pump timer relay; **X12**–drain valve lockout relay 1; **X13**–drain valve lockout relay 2

B. Control Board Check

Before replacing CB that does not show a visible defect and that you suspect is bad, always conduct the following check procedure. This procedure will help you verify your diagnosis.

Alarm Reset: If CB is in alarm (beeping), press the "ALARM RESET" button on CB while CB is beeping. **WARNING! Risk of electric shock. Care should be taken not to touch live terminals.** Once reset, the icemaker starts at the 1-minute fill cycle. For audible alarm information, see "II.C.2. LED Lights and Audible Alarm Safeties."

- 1) Check the dip switch settings to assure that S4 dip switch 3, 4, 7, 8, 9, 10, and S5 dip switch 1 through 5 are in the factory default position. S4 dip switch 1, 2, 5, 6 are cleaning adjustments and the settings are flexible. For factory default settings, see "II.C.3.a) Default Dip Switch Settings."
- 2) Move the control switch to the "ICE" position. If the red "POWER OK" LED is on, control voltage is good, continue to step 3. If the red "POWER OK" LED is off, check CT secondary circuit. CT output is 10.5VAC at 115VAC primary input. If the secondary circuit has proper voltage and the red LED is off, replace CB.

If the secondary circuit does not have proper voltage, check CT primary circuit. Check for 115VAC at CB K1 connector pin #10 (BR wire) to a neutral (W wire) for 115VAC. (Always choose a neutral (W wire) to establish a good neutral connection when checking voltages.) For additional checks, see "IV.F.1. No Ice Production."
- 3) The "OUTPUT TEST" button provides a relay sequence test. Make sure the control switch is in the "ICE" position, then press the "OUTPUT TEST" button. The correct lighting sequence is 1, 4, 3, 2. Note that the order of the LEDs from the outer edge of CB is 1, 4, 3, 2. Components (e.g., compressor) will cycle during the test. Following the test, the icemaker begins operation at the 1-minute fill cycle. If the LEDs do not light as described above, replace CB.
- 4) To verify voltage output from CB to the components, slide the CB K1 connector out far enough to allow multimeter lead contact. With the icemaker in the cycle to be tested, check output voltage from the corresponding pin on CB K1 connector to ground. If output voltage is not found and the appropriate LED is on, replace CB.

Legend: **CB**—control board; **CT**—control transformer.

C. Bin Control Check and Cleaning

This icemaker uses a BC with a lever-actuated proximity switch to control the ice level in the storage bin. No adjustment is required.

1. Bin Control Check

To check BC, follow the steps below.

- 1) Turn off the power supply.
- 2) Remove the front panel, then move the control switch to the "OFF" position.
- 3) Remove the top and right side panels. Remove the control box cover, then clear any ice away from BC.
- 4) Check BC wire harness connections. See Fig. 1.
- 5) Disconnect BC connector from CB K4 (red) connector.
- 6) Check for continuity across the wires of BC connector. When the actuator paddle is not engaged, BC switch is closed. If open, check that the wire harness connector is properly connected and that the actuator paddle is not sticking. Clean if necessary. See "IV.C.2. Bin Control Cleaning." If BC switch still reads open, replace BC.
- 7) Press and hold the actuator paddle; check for continuity across the wires of BC connector. When the actuator paddle is engaged, BC switch is open. If closed, check that the actuator paddle is not restricted. Clean if necessary. See "IV.C.2. Bin Control Cleaning." If BC switch still reads closed, replace BC.
- 8) Reconnect BC connector to CB K4 (red) connector, then move the control switch to the "ICE" position. Turn on the power supply.
- 9) Check that the green "BC CLOSED" LED on CB is on.
- 10) Allow the icemaker to cycle on. Press and hold the actuator paddle. The yellow "BC OPEN" LED should be on and the icemaker should shut down according to the chart below. If it does not, replace CB.

Cycle at Bin Control Activation	Shutdown
Fill Cycle	15 seconds after activation.
Harvest Cycle	At the end of the harvest cycle, or up to 15 seconds into the freeze cycle if activated at the end of the harvest cycle.
Freeze Cycle	15 seconds after activation if activated at least 15 seconds before the 5-minute short cycle protection timer terminates. Otherwise, at the end of the next harvest cycle.

Legend: **BC**—bin control; **CB**—control board

2. Bin Control Cleaning

Scale may build up on BC. Scale can cause the actuator paddle and magnet to stick. In this case, BC should be cleaned.

⚠ WARNING

CHOKING HAZARD: Ensure all components, fasteners, and thumbscrews are securely in place after the icemaker is serviced. Make sure that none have fallen into the dispenser unit/storage bin.

- 1) Turn off the power supply.
- 2) Remove the front panel, then move the control switch to the "OFF" position.
- 3) Remove the top and right side panels. Remove the control box cover, then clear any ice away from BC.
- 4) Disconnect BC connector from CB K4 (red) connector, then remove BC from the icemaker.
- 5) Remove the actuator paddle from the switch mount. See Fig. 1.
- 6) Wipe down BC with a mixture of 1 part Hoshizaki "Scale Away" and 25 parts warm water. Rinse the parts thoroughly with clean water.
- 7) Reassemble BC and replace it in its correct position.
Note: If the magnet was removed for cleaning, be sure to replace it in its correct position.
- 8) Reconnect BC connector to CB K4 (red) connector.
- 9) Move the control switch to the "ICE" position.
- 10) Replace the control box cover, right side, top, and front panels in their correct positions.
- 11) Turn on the power supply to start the automatic icemaking process.

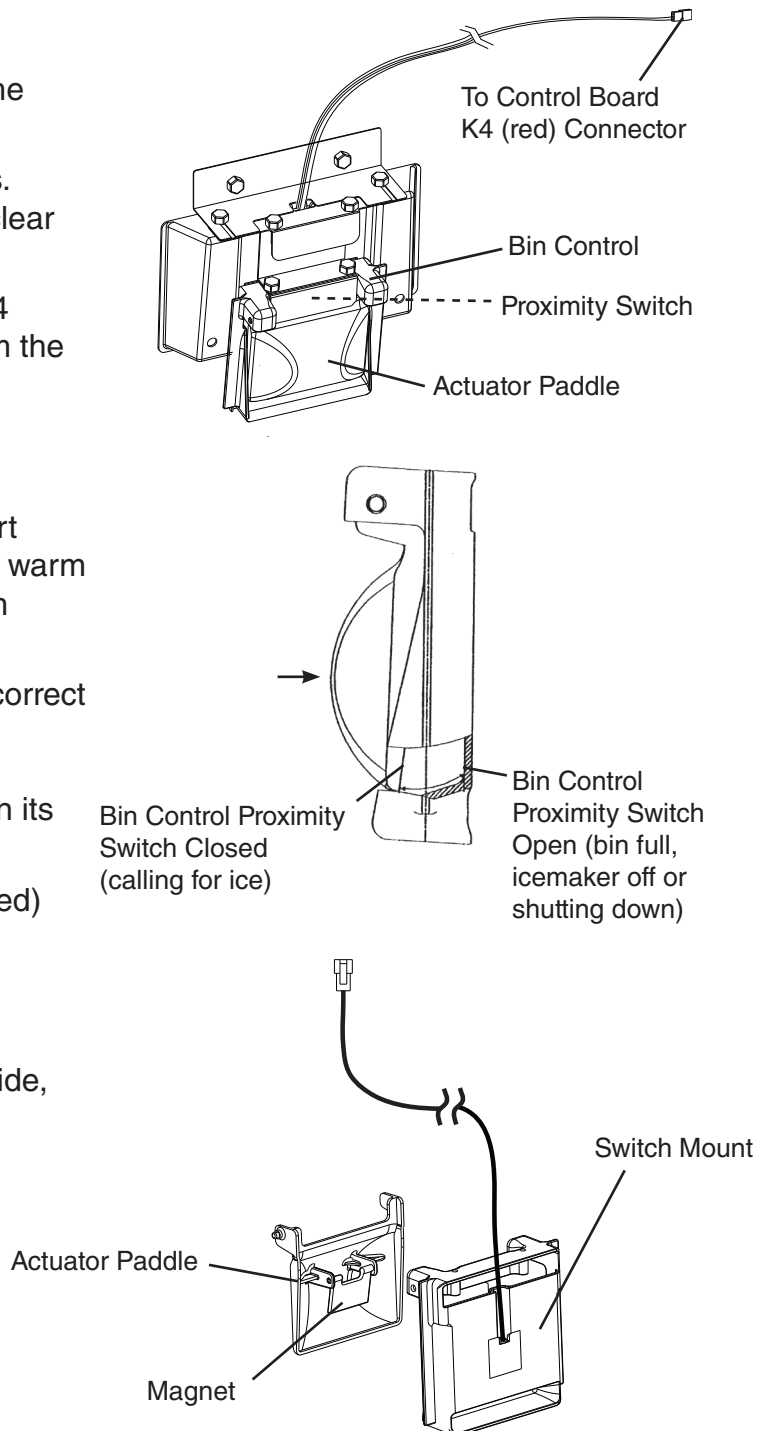

Fig. 1

D. Float Switch Check and Cleaning

F/S is used to determine that there is sufficient water in the water tank after the 1-minute fill cycle and after each harvest cycle. F/S is also used to determine that the appropriate volume of water has been converted into ice before switching out of the freeze cycle. No adjustment is required.

1. Float Switch Check

To check F/S, follow the steps below.

- 1) Turn off the power supply.
- 2) Remove the front panel.
- 3) Place the control switch in the "SERVICE" position. Then place the service switch in the "DRAIN" position.
- 4) Replace the front panel in its correct position, then turn on the power supply for 2 minutes.
- 5) Turn off the power supply.
- 6) Remove the front panel, then move the control switch to the "OFF" position.
- 7) Remove the top and right side panels.
- 8) Remove the control box cover, then disconnect F/S connector from CB K5 (black) connector.
- 9) Check for continuity across F/S leads. With the water tank empty, F/S should be open. If open, continue to step 10. If closed, follow the steps in "IV.D.2. Float Switch Cleaning." After cleaning F/S, check it again. Replace if necessary.
- 10) Reconnect F/S connector to CB K5 (black) connector, then replace the control box cover, right side, and top panels in their correct positions.
- 11) Move the control switch to "ICE" position. Replace the front panel.
- 12) Turn on the power supply.
- 13) As water fills the water tank, F/S contacts should close. After 1 minute, the 1-minute fill cycle should end and the initial harvest cycle should begin.
- 14) Once the harvest cycle starts, turn off the power supply.
- 15) Remove the front panel, then move the control switch to the "OFF" position.
- 16) Remove the top and right side panels.
- 17) Remove the control box cover, then disconnect F/S connector from CB K5 (black) connector.
- 18) Check for continuity across F/S leads. With the water tank full, F/S should be closed. If F/S is closed and the icemaker will not switch from the 1-minute fill cycle to the initial harvest cycle, replace CB.
- 19) If open, confirm that the water tank is full. If the water tank is not full, check the water supply, water filters, and fill/refill water valve. If the water tank is full, follow the steps in "IV.D.2. Float Switch Cleaning." After cleaning F/S, check it again. Replace if necessary.

- 20) Reconnect F/S connector to CB K5 (black) connector, then replace the control box cover, right side, and top panels in their correct positions.
- 21) Move the control switch to the "ICE" position.
- 22) Replace the front panel in its correct position.
- 23) Turn on the power supply to start the automatic icemaking process.

Legend: **CB**—control board; **F/S**—float switch

2. Float Switch Cleaning

Depending on local water conditions, scale may build up on F/S. Scale can cause F/S to stick. In this case, F/S should be cleaned.

- 1) Turn off the power supply.
- 2) Remove the front panel.
- 3) Place the control switch in the "SERVICE" position. Then place the service switch in the "DRAIN" position.
- 4) Replace the front panel in its correct position, then turn on the power supply for 2 minutes.
- 5) Turn off the power supply.
- 6) Remove the front, top, and right side panels, then move the control switch to the "OFF" position.
- 7) Disconnect the vent tube and the flush tube from the top of F/S housing, then remove F/S assembly. Remove the rubber boot from the bottom of F/S assembly. See Fig. 2.
- 8) Remove the retainer rod from the bottom of F/S assembly, then remove the float. Be careful not to bend the retainer rod excessively when removing it.
- 9) Wipe down F/S assembly's housing, shaft, float, and retainer rod with a mixture of 1 part Hoshizaki "Scale Away" and 25 parts warm water. Clean the inside of the rubber boot and hose with cleaning solution. Rinse the parts thoroughly with clean water.
- 10) Reassemble F/S assembly and replace it and the rubber boot in their correct positions. Reconnect the vent tube and the flush tube.
- 11) Replace the right side and top panels in their correct positions.
- 12) Move the control switch to the "ICE" position.
- 13) Replace the front panel in its correct position.
- 14) Turn on the power supply to start the automatic icemaking process.

Legend: **CB**—control board; **F/S**—float switch

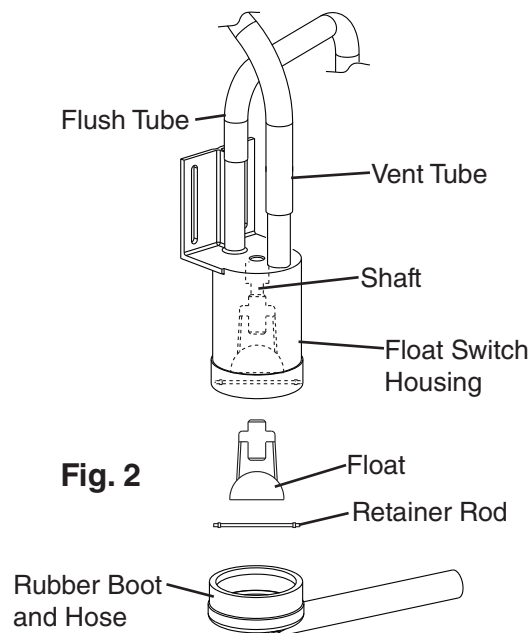

E. Thermistor Check

To check thermistor resistance, follow the steps below.

- 1) Turn off the power supply.
- 2) Remove the front panel, then move the control switch to the "OFF" position.
- 3) Remove the top and right side panels, then remove the control box cover.
- 4) Remove the thermistor.
- 5) Immerse the thermistor sensor portion in a glass containing ice and water for 2 or 3 minutes.
- 6) Disconnect the thermistor connector from CB K3 (white) connector and check resistance between thermistor leads. Normal range is 4.7 to 6.2 k Ω . If outside the normal range, replace the thermistor. See "V.B. Important Notes for Component Replacement." If within the normal range, continue to next step.
- 7) Replace the thermistor in its correct position. See "V.B. Important Notes for Component Replacement."
- 8) Reconnect the thermistor connector to CB K3 (white) connector.
- 9) Replace the control box cover, right side, and top panels in their correct positions.
- 10) Move the control switch to the "ICE" position.
- 11) Replace the front panel in its correct position.
- 12) Turn on the power supply.
- 13) Once the harvest cycle starts (Comp energizes), begin timing the harvest cycle.
- 14) The harvest timer and harvest cycle should terminate within 2 to 5 minutes. If the harvest cycle does not terminate within 2 to 5 minutes, replace CB.

Legend: **CB**—control board; **Comp**—compressor

F. Diagnostic Charts

1. No Ice Production

No Ice Production - Possible Cause	
1. Power Supply	a) Off, blown fuse, or tripped breaker.
	b) Not within specifications.
2. Main Transformer (208-230VAC/115VAC) (3 Phase Only)	a) Voltage tap switch not set to proper voltage.
	b) Coil winding open or shorted.
3. Water Supply	a) Water supply off or improper water pressure.
	b) External water filters clogged.
4. Fuse (SRK Control Box)	a) Blown.
5. High-Pressure Switch (SRK)	a) Dirty condenser.
	b) Condensing unit fan(s) not operating.
	c) Headmaster (C.P.R.) open.
	d) Refrigerant overcharged.
	e) Bad contacts.
	f) Refrigerant lines or components plugged.
6. Discharge Line Thermostat (SRK)	a) Ambient temperature too warm.
	b) Compressor or compressor components faulty.
	c) Defective.
	d) Hot gas valves open.
	e) Dirty condenser.
	f) Condensing unit fan not operating.
7. Wire Harness (From SRK to KMS)	a) Disconnected or loose connection.
8. Fuse (KMS Switch Box)	a) Blown.
9. Control Switch	a) In "SERVICE" or "OFF" position.
	b) Bad contacts.
10. Control Transformer (115VAC/10.5VAC)	a) Coil winding open or shorted.
11. Control Board See "IV.B. Control Board Check"	a) In alarm.
	b) Yellow "BC OPEN" LED on (bin full).
	c) Defective.
12. Bin Control See "IV.C. Bin Control Check and Cleaning"	a) Tripped with bin filled with ice.
	b) Actuator does not move freely.
	c) Defective.
13. Fill/Refill or Harvest Water Valve	a) Screen or orifice clogged.
	b) Coil winding open.
	c) Water valve open in freeze cycle.
14. Float Switch See "IV.D. Float Switch Check and Cleaning"	a) Float does not move freely.
	b) Defective.

No Ice Production - Possible Cause	
15. Compressor	a) Compressor relay/magnetic contactor contacts bad or coil winding open.
	b) Start capacitor or run capacitor defective (single phase only).
	c) Internal protector open.
	d) Start relay contacts bad or coil winding open (single phase only).
	e) Protector tripped.
	f) Compressor defective.
16. Hot Gas Valves (KMS & SRK)	a) Closed in harvest cycle.
	b) Open in freeze cycle.
17. Thermistor See "IV.E. Thermistor Check"	a) Loose, disconnected, or defective.
18. Pump Motor	a) Motor winding open.
	b) Bearing worn out or locked rotor.
	c) Defective capacitor.
	d) Mechanical seal worn out.
19. Thermostatic Expansion Valve	a) Bulb loose.
	b) Operating erratically.
20. Liquid Line Valves (KMS & SRK)	a) Closed in freeze cycle.
	b) Open in harvest cycle.
21. Fan Motors-Remote	a) Motor winding open.
	b) Bearing worn out or locked rotor.
	c) Defective capacitor.
22. Headmaster (C.P.R.)	a) Defective.
23. Water System	a) Water leaks causing short freeze time.

2. Freeze-Up

Defrost and clean the icemaker prior to diagnosing freeze-up. See "VI.A. Cleaning and Sanitizing Instructions." Fill out a freeze-up checklist. The freeze-up checklist can be found in the Hoshizaki Technician's Pocket Guide or contact your local distributor for a copy of the freeze-up checklist.

Freeze-Up - Possible Cause	
Harvest Cycle	
1. Evaporator	a) Scaled up.
	b) Damaged.
2. Cube Guides	a) Out of position.
	b) Damaged.
3. Spray Tubes and/or Spray Guides	a) Dirty.
	b) Out of position.
4. Water Supply	a) Low water pressure.
	b) External water filters clogged.
	c) Insufficient water line size. Minimum 3/8" nominal ID copper water tubing or equivalent.
5. Harvest Water Valve	a) Screen or orifice clogged.
	b) Defective.

Freeze-Up - Possible Cause	
6. Float Switch See "IV.D. Float Switch Check and Cleaning"	a) Dirty, sticking.
	b) Defective.
7. Refrigerant Charge	a) Low.
8. Control Board See "II.C.3. Controls and Adjustments" and "IV.B. Control Board Check"	a) Harvest timer (S4 dip switch 1 & 2) set too short.
	b) Harvest pump timer (S4 dip switch 7) not in factory default position.
	c) Defective.
9. Bin Control See "IV.C. Bin Control Check and Cleaning"	a) Actuator does not move freely.
10. Thermistor See "IV.E. Thermistor Check"	a) Loose, disconnected, or defective.
11. Thermostatic Expansion Valve	a) Defective.
12. Hot Gas Valves (KMS & SRK)	a) Closed or restricted.
13. Liquid Line Valves (KMS & SRK)	a) Open.
Freeze Cycle	
1. Evaporator	a) Scaled up.
	b) Damaged.
2. Spray Tubes and/or Spray Guides	a) Dirty.
	b) Out of position.
3. Refrigerant Charge	a) Low.
4. Control Board See "IV.B. Control Board Check"	a) Freeze timer (S4 dip switch 9 & 10) set incorrectly.
	b) Defective.
5. Fill/Refill or Harvest Water Valve	a) Leaking by.
6. Float Switch See "IV.D. Float Switch Check and Cleaning"	a) Float does not move freely.
	b) Defective.
7. Pump Motor	a) RPM too slow.
	b) Impeller damaged.
8. Thermostatic Expansion Valve	a) Bulb loose or defective.
9. Headmaster (C.P.R.)	a) Defective.
10. Liquid Line Valves (KMS & SRK)	a) Restricted.

3. Low Ice Production

Low Ice Production - Possible Cause	
Long Harvest Cycle	
1. Evaporator	a) Scaled up.
2. Spray Tubes and/or Spray Guides	a) Dirty.
	b) Out of position.
3. Refrigerant Charge	a) Low.
4. Water Supply	a) Low water pressure.
	b) External water filters clogged.
	c) Insufficient water line size. Minimum 3/8" nominal ID copper water tubing or equivalent.
	d) Too cold.
5. Control Board See "IV.B. Control Board Check"	a) Thermistor connection loose (K3).
	b) Defective.
6. Thermistor See "IV.E. Thermistor Check"	a) Loose, disconnected, or defective.
7. Hot Gas Valves (KMS & SRK)	a) Erratic or closed.
8. Harvest Water Valve	a) Screen or orifice clogged.
9. Compressor	a) Inefficient or off.
10. Liquid Line Valves (KMS & SRK)	a) Erratic or open.
11. Thermostatic Expansion Valve (TXV)	a) Defective.
12. Headmaster (C.P.R.)	a) Defective.
Long Freeze Cycle	
1. Evaporator	a) Scaled up, dirty.
2. Float Switch See "IV.D. Float Switch Check and Cleaning"	a) Scaled up, dirty.
	b) Float sticking.
	c) Defective switch.
3. Fill/Refill or Harvest Water Valve	a) Leaking by.
4. Hot Gas Valves (KMS & SRK)	a) Erratic or open.
5. Condenser	a) Clogged.
6. Control Board See "IV.B. Control Board Check"	a) Float switch connection loose (K5).
	b) Defective.
7. Refrigerant Charge	a) Low.
8. Thermostatic Expansion Valve (TXV)	a) Bulb loose.
	b) Defective.
9. Compressor	a) Inefficient or off.
10. Pump Motor	a) RPM too slow.
11. Liquid Line Valves (KMS & SRK)	a) Erratic or restricted.
12. Headmaster (C.P.R.)	a) Defective.

V. Replacement of Components

WARNING

- This icemaker should be diagnosed and repaired only by qualified service personnel to reduce the risk of death, electric shock, serious injury, or fire.
- Move the control switch to the "OFF" position and turn off the power supply before servicing. Lockout/Tagout to prevent the power from being turned back on inadvertently.
- **CHOKING HAZARD:** Ensure all components, fasteners, and thumbscrews are securely in place after the icemaker is serviced. Make sure that none have fallen into the dispenser unit/storage bin.
- Make sure all food zones in the icemaker and dispenser unit/storage bin are clean after service. For cleaning procedures, see "VI. Cleaning and Maintenance."

A. Service for Refrigerant Lines

WARNING

- Repairs requiring the refrigeration circuit to be opened must be performed by properly trained and EPA-certified service personnel.
- Use an electronic leak detector or soap bubbles to check for leaks. Add a trace of refrigerant to the system (if using an electronic leak detector), and then raise the pressure using nitrogen gas (140 PSIG). DO NOT use R-404A as a mixture with pressurized air for leak testing.

NOTICE

- Always recover the refrigerant and store it in an approved container. Do not discharge the refrigerant into the atmosphere.
- Do not leave the system open for longer than 15 minutes when replacing or servicing parts. The Polyol Ester (POE) oils used in R-404A applications can absorb moisture quickly. Therefore it is important to prevent moisture from entering the system when replacing or servicing parts.
- Always install a new drier every time the sealed refrigeration system is opened. Do not replace the drier until after all other repair or replacement has been made. Install the new drier with the arrow on the drier in the direction of the refrigerant flow.
- When brazing, protect the drier by using a wet cloth to prevent the drier from overheating. Do not allow the drier to exceed 250°F (121°C).

1. Refrigerant Recovery

The condensing unit is provided with refrigerant shutoff valves and the icemaker is provided with refrigerant service valves. Using proper refrigerant practices, recover the refrigerant. Recovery via the condensing unit's refrigerant shutoff valves is recommended. Store the refrigerant in an approved container. Do not discharge the refrigerant into the atmosphere.

2. Brazing

⚠ WARNING

- R-404A itself is not flammable at atmospheric pressure and temperatures up to 176°F (80°C).
- R-404A itself is not explosive or poisonous. However, when exposed to high temperatures (open flames), R-404A can be decomposed to form hydrofluoric acid and carbonyl fluoride both of which are hazardous.
- Do not use silver alloy or copper alloy containing arsenic.
- Use an electronic leak detector or soap bubbles to check for leaks. Add a trace of refrigerant to the system (if using an electronic leak detector), and then raise the pressure using nitrogen gas (140 PSIG). DO NOT use R-404A as a mixture with pressurized air for leak testing.

- 1) Braze all fittings while purging with nitrogen gas flowing at a pressure of 3 to 4 PSIG.
Note: Because the pipes in the evaporator case are specially coated to resist corrosion, it is important to make connections outside the evaporator case when possible. If it is necessary to braze inside the evaporator case, use sandpaper to remove the coating from the brazing connections before unbrazing the components.

NOTICE

- Always install a new drier every time the sealed refrigeration system is opened. Do not replace the drier until after all other repair or replacement has been made. Install the new drier with the arrow on the drier in the direction of the refrigerant flow.
- When brazing, protect the drier by using a wet cloth to prevent the drier from overheating. Do not allow the drier to exceed 250°F (121°C).

- 2) Use an electronic leak detector or soap bubbles to check for leaks. Add a trace of refrigerant to the system (if using an electronic leak detector), and then raise the pressure using nitrogen gas (140 PSIG). Do not use R-404A as a mixture with pressurized air for leak testing.

3. Evacuation and Recharge (R-404A)

The condensing unit is provided with refrigerant shutoff valves and the icemaker is provided with refrigerant service valves. Evacuation and recharge via the condensing unit's refrigerant shutoff valves is recommended.

- 1) Attach a vacuum pump to the system. Be sure to connect the charging hoses to both high and low-side refrigerant shutoff valves.

IMPORTANT

The vacuum level and vacuum pump may be the same as those for current refrigerants. However, the rubber hose and gauge manifold to be used for evacuation and refrigerant charge should be exclusively for POE oils.

- 2) Turn on the vacuum pump. Open the gauge manifold valves, then open the high and low-side refrigerant shutoff valves. Never allow the oil in the vacuum pump to flow backwards.
- 3) Allow the vacuum pump to pull down to a 29.9" Hg vacuum. Evacuating period depends on pump capacity.
- 4) Close the low-side valve and high-side valve on the gauge manifold.
- 5) Disconnect the gauge manifold hose from the vacuum pump and attach it to a refrigerant service cylinder. Remember to loosen the connection and purge the air from the hose. For the required refrigerant charge, see the nameplate on the condensing unit or the rating label inside the icemaker. Hoshizaki recommends only virgin refrigerant or reclaimed refrigerant which meets ARI Standard 700 (latest edition) be used.
- 6) A liquid charge is required when charging an R-404A system (to prevent fractionation). Place the service cylinder on the scales; if the service cylinder is not equipped with a dip tube, invert the service cylinder, then place it on the scales. Open the high-side valve on the gauge manifold.
- 7) Allow the system to charge with liquid until the proper charge weight is met.
- 8) If necessary, add any remaining charge to the system through the low-side. **NOTICE! To prevent compressor damage, use a throttling valve or liquid dispensing device to add the remaining liquid charge through the low-side refrigerant shutoff valve with the icemaker running.**
- 9) Close the high and low-side refrigerant shutoff valves. Close the high and low-side gauge manifold valves, then disconnect the gauge manifold hoses.
- 10) Cap the refrigerant shutoff valves to prevent a possible leak.

B. Important Notes for Component Replacement

NOTICE

When replacing a component listed below, see the notes to help ensure proper operation.

Component	Notes
Compressor	1 Phase: Install a new start capacitor, run capacitor, and start relay. 3 Phase: Install a new magnetic contactor.
Thermostatic Expansion Valve	<ul style="list-style-type: none"> • Attach the thermostatic expansion valve bulb to the suction line in the same location as the previous bulb. • The bulb should be between the 10 and 2 o'clock positions on the tube. • Secure the bulb with the clamp and holder, then insulate it.
Hot Gas Valves Liquid Line Valves	<ul style="list-style-type: none"> • Replace the strainer if applicable. • Use copper tube of the same diameter and length when replacing valve lines.
Fan Motor	Install a new capacitor.
Pump Motor	Install a new capacitor.
Thermistor	<ul style="list-style-type: none"> • Attach the new thermistor to the suction line in the same location as the previous thermistor. • The thermistor should be at the 12 o'clock position on the tube. • Smoothly fill the recessed area of the thermistor holder with high thermal conductive type sealant. Hoshizaki America part number 4A0683-01 (Silicone Heat Sink Compound 10-8108 manufactured by GC Electronics), KE-4560 RTV (manufactured by ShinEtsu Silicones), or equivalent are recommended. • Secure the thermistor with the holder, then insulate it. • Be very careful to prevent damage to the leads.

VI. Cleaning and Maintenance

This icemaker must be cleaned and maintained in accordance with the instruction manual and labels provided with the icemaker. Consult with your local Hoshizaki Certified Service Representative about cleaning and maintenance service.

⚠ WARNING

- Only qualified service technicians should service this icemaker.
- **CHOKING HAZARD:** Ensure all components, fasteners, and thumbscrews are securely in place after any cleaning or maintenance is done to the icemaker. Make sure that none have fallen into the dispenser unit/storage bin.

NOTICE

The dispenser unit/storage bin is for ice use only. Do not store anything else in the dispenser unit/storage bin.

A. Cleaning and Sanitizing Instructions

This icemaker must be cleaned and sanitized at least once a year. More frequent cleaning and sanitizing may be required in some water conditions.

⚠ WARNING

- To prevent injury to individuals and damage to the icemaker, do not use ammonia type cleaners.
- Carefully follow any instructions provided with the bottles of cleaning and sanitizing solution.
- Always wear liquid-proof gloves and goggles to prevent the cleaning and sanitizing solutions from coming into contact with skin or eyes.

NOTICE

To prevent damage to the water pump seal, do not operate the icemaker with the control switch in the "SERVICE" position when the water tank is empty.

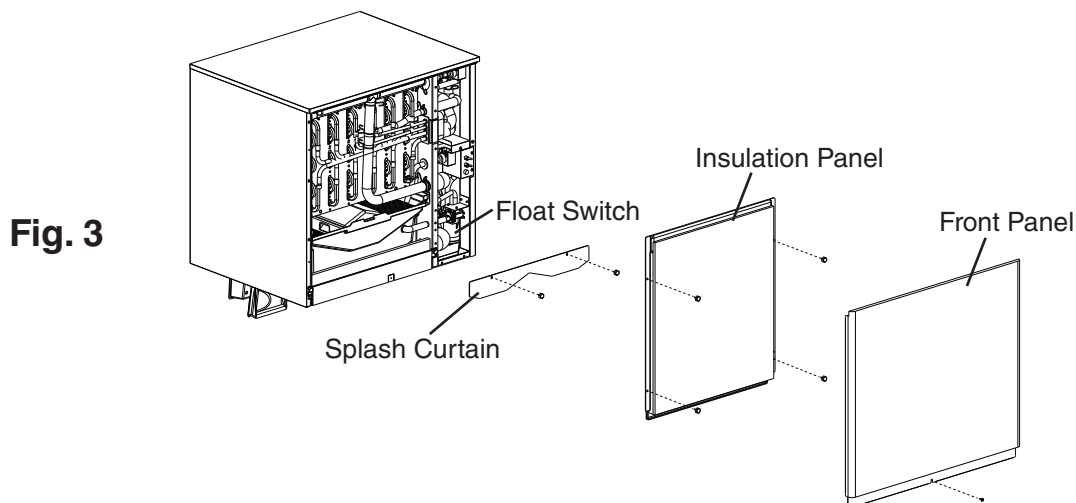

1. Cleaning Procedure

- 1) Dilute 22 fl. oz. (650 ml) of Hoshizaki "Scale Away" with 4 gal. (15 l) of warm water.
- 2) Remove all ice from the evaporator and the dispenser unit/storage bin.
Note: To remove cubes on the evaporator, turn off the power supply and turn it back on after 3 minutes. The harvest cycle starts and the cubes will be removed from the evaporator.
- 3) Turn off the power supply.
- 4) Remove the front panel, then place the control switch in the "SERVICE" position. Place the service switch in the "DRAIN" position.
- 5) Replace the front panel in its correct position, then turn on the power supply for 2 minutes.
- 6) Turn off the power supply.
- 7) Remove the front panel.
- 8) In bad or severe water conditions, clean the float switch as described below. Otherwise, continue to step 9.
 - a. Remove the right side panel.
 - b. Disconnect the vent tube and the flush tube from the top of the float switch housing, then remove the float switch assembly. Remove the rubber boot from the bottom of the float switch assembly.
 - c. Remove the retainer rod from the bottom of the float switch assembly, then remove the float. Be careful not to bend the retainer rod excessively when removing it.
 - d. Wipe down the float switch assembly's housing, shaft, float, and retainer rod with cleaning solution. Clean the inside of the rubber boot and hose with cleaning solution. Rinse the parts thoroughly with clean water.
 - e. Reassemble the float switch assembly and replace it and the rubber boot in their correct positions. Reconnect the vent tube and the flush tube.
 - f. Replace the right side panel in its correct position.
- 9) Remove the insulation panel and splash curtain, then pour the cleaning solution into the water tank.
- 10) Move the service switch to the "WASH" position.
- 11) Replace the splash curtain, insulation panel, and front panel in their correct positions.
- 12) Turn on the power supply to start the washing process.
- 13) Turn off the power supply after 30 minutes. Remove the front panel.
- 14) Move the service switch to the "DRAIN" position.
- 15) Replace the front panel in its correct position, then turn on the power supply for 2 minutes.
- 16) Turn off the power supply, then remove the front panel.
- 17) Move the control switch to the "ICE" position.
- 18) Replace the front panel in its correct position.
- 19) Turn on the power supply to fill the water tank with water.
- 20) Turn off the power supply after 3 minutes.

- 21) Remove the front panel.
- 22) Move the control switch to the "SERVICE" position, then move the service switch to the "WASH" position.
- 23) Replace the front panel in its correct position.
- 24) Turn on the power supply to rinse off the cleaning solution.
- 25) Turn off the power supply after 5 minutes.
- 26) Remove the front panel.
- 27) Move the service switch to the "DRAIN" position.
- 28) Replace the front panel in its correct position, then turn on the power supply for 2 minutes.
- 29) Turn off the power supply. Remove the front panel.
- 30) Repeat steps 17 through 29 three more times to rinse thoroughly.
Note: If you do not sanitize the icemaker, go to step 13 in "2. Sanitizing Procedure."

2. Sanitizing Procedure - Following Cleaning Procedure

- 1) Dilute 2 fl. oz. (60 ml or 4 tbs) of a 5.25% sodium hypochlorite solution (chlorine bleach) with 4 gal. (15 l) of warm water.
- 2) Remove the front panel, insulation panel, and splash curtain if they are in their normal positions.
- 3) Pour the sanitizing solution into the water tank.
- 4) Move the service switch to the "WASH" position.
- 5) Replace the splash curtain, insulation panel, and front panel in their correct positions.
- 6) Turn on the power supply to start the sanitizing process.
- 7) Turn off the power supply after 15 minutes. Remove the front panel.
- 8) Move the service switch to the "DRAIN" position.
- 9) Replace the front panel in its correct position, then turn on the power supply for 2 minutes.
- 10) Turn off the power supply. Remove the front panel.
- 11) Repeat steps 17 through 29 in "1. Cleaning Procedure" two times to rinse thoroughly.
- 12) Repeat steps 1 through 11 one more time.
- 13) Move the control switch to the "ICE" position.
- 14) Replace the front panel in its correct position.
- 15) Clean the dispenser unit/storage bin liner using a neutral cleaner. Rinse thoroughly after cleaning.
- 16) Turn on the power supply to start the automatic icemaking process.

B. Maintenance

This icemaker must be maintained individually, referring to the instruction manual and labels provided with the icemaker.

WARNING

- Only qualified service technicians should service this icemaker.
- Move the control switch to the "OFF" position and turn off the power supply to the SRK condensing unit before servicing the KMS or SRK. Place the KMS disconnect (if applicable) in the off position. Lockout/Tagout to prevent the power supply from being turned back on inadvertently.

1. Stainless Steel Exterior

To prevent corrosion, wipe the exterior occasionally with a clean, soft cloth. Use a damp cloth containing a neutral cleaner to wipe off oil or dirt buildup.

2. Storage Bin Scoop

- Wash your hands before removing ice from the storage bin. Use the plastic scoop provided (storage bin accessory).
- Clean the scoop using a neutral cleaner. Rinse thoroughly after cleaning.

3. Dispenser Unit/Storage Bin

- The dispenser unit/storage bin is for ice use only. Do not store anything else in the dispenser unit/storage bin.
- Clean the dispenser unit/storage bin liner using a neutral cleaner. Rinse thoroughly after cleaning.

4. Condenser

Check the condenser once a year, and clean the coil if required by using a brush or vacuum cleaner. More frequent cleaning may be required depending on location.

C. Preparing the Icemaker for Periods of Non-Use

NOTICE

- When storing the icemaker for an extended time or in sub-freezing temperatures, follow the instructions below to prevent damage.
- To prevent damage to the water pump, do not operate the icemaker with the control switch in the "SERVICE" position when the water tank is empty.

When the icemaker is not used for two or three days under normal conditions, it is sufficient to move the control switch to the "OFF" position. When storing the icemaker for an extended time or in sub-freezing temperatures, follow the instructions below.

- 1) Turn off the power supply, then remove the front panel.
- 2) Move the control switch on the control box to the "OFF" position. Confirm that the service switch is in the "CIRC." position.
- 3) Remove the front insulation, front frame, right side panel, and control box cover.
- 4) Disconnect the thermistor connector from the control board K3 (white) connector, then unplug the water pump connector at the water pump.
- 5) Wait 3 minutes, then move the control switch to the "ICE" position. Confirm that the bin control switch is closed and calling for ice. The green "BC CLOSED" LED on the control board should be on.
- 6) Once LED 1 and 2 on the control board energize (the order of the LEDs from the outer edge of the control board is 1, 4, 3, 2), close the inlet water supply line shut-off valve and open the inlet water supply line drain valve. Allow the line to drain by gravity.
- 7) Disconnect the harvest water valve hose in the evaporator section and blow out the water line to the harvest water valve using compressed air or carbon dioxide. See Fig. 4. This will clear water from the harvest water valve.
- 8) Move the control switch to the "OFF" position.
- 9) Move the service switch to the "WASH" position and the control switch to the "SERVICE" position.
- 10) Using the same hose as with the harvest water valve, blow out the wash valve using compressed air or carbon dioxide.
- 11) Move the service switch to the "CIRC." position and the control switch to the "OFF" position.
- 12) Remove the 4 hoses connected to the water tank. Allow the water tank and hoses to completely drain.
- 13) Move the control switch to the "ICE" position.
- 14) Using the fill/refill water valve hose, blow out the water line using compressed air or carbon dioxide. This will clear water from the fill/refill water valve.
- 15) Move the control switch to the "OFF" position.
- 16) Disconnect the float switch flush tube from the drain hose tee. Move the service switch to the "DRAIN" position and the control switch to the "SERVICE" position.

- 17) From the tee on the drain hose, blow out the drain valve using compressed air or carbon dioxide.
- 18) Move the service switch to the "CIRC." position and the control switch to the "OFF" position.
- 19) Turn off the power supply.
- 20) Reconnect the thermistor connector to the control board K3 (white) connector. Reconnect the water pump connector.
- 21) Close the inlet water supply line drain valve.
- 22) Remove all ice from the dispenser unit/storage bin and clean the dispenser unit/storage bin liner using a neutral cleaner. Rinse thoroughly after cleaning.
- 23) Replace all removed parts and panels in their correct positions.

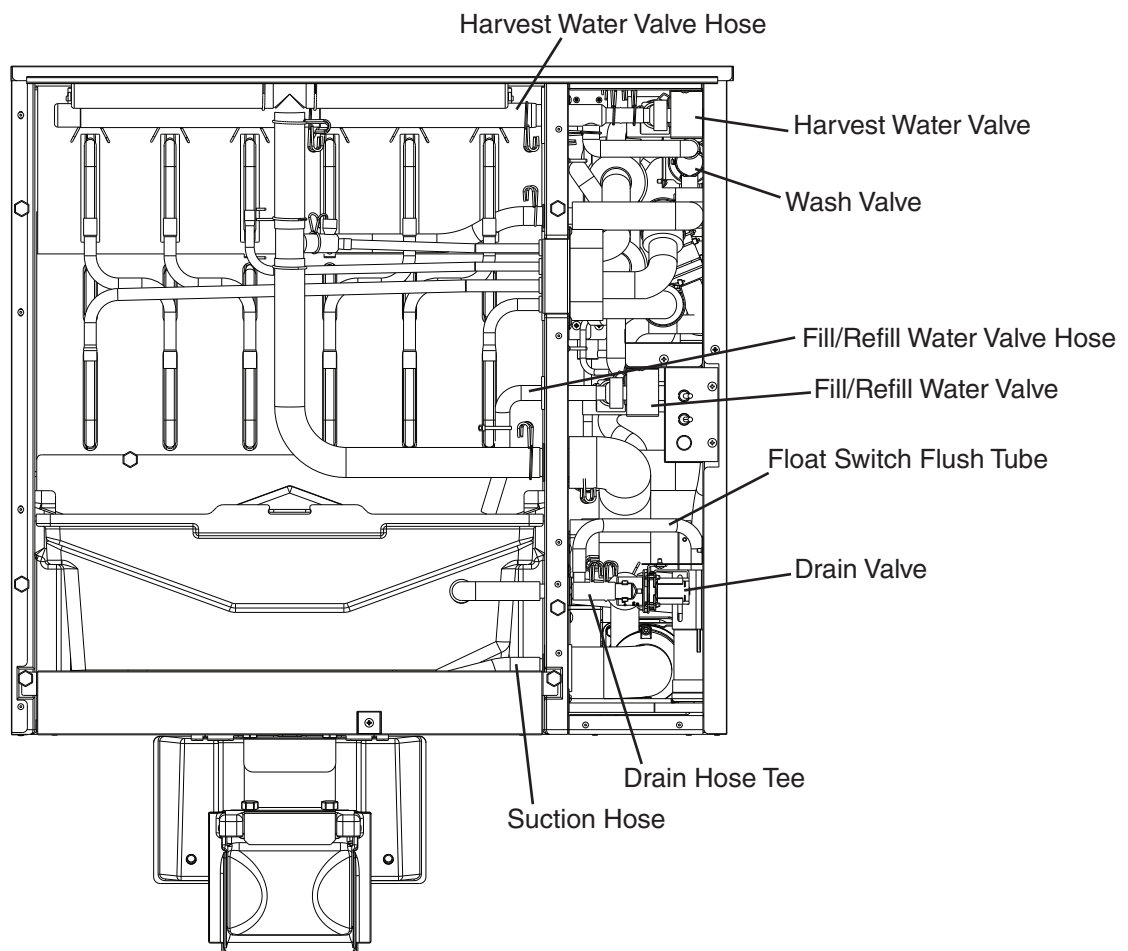

Fig. 4

VII. Disposal

This icemaker contains refrigerant and must be disposed of in accordance with applicable national, state, and local codes and regulations. Refrigerant must be recovered by properly certified service personnel.