

Hoshizaki America, Inc.

Modular Crescent Cuber Serenity Series

Model
KMS-1401MLJ

Including
Condensing Unit Models
SRK-14J/3



“A Superior Degree
of Reliability”

www.hoshizaki.com

INSTRUCTION MANUAL



Issued: 10-11-2011
Revised: 7-22-2013

⚠ WARNING

Only qualified service technicians should install and service the icemaker. To obtain the name and phone number of your local Hoshizaki Certified Service Representative, visit www.hoshizaki.com. No installation or service should be undertaken until the technician has thoroughly read this Instruction Manual. Likewise, the owner/manager should not proceed to operate the icemaker until the installer has instructed them on its proper operation. Failure to install, operate, and maintain the equipment in accordance with this manual will adversely affect safety, performance, component life, and warranty coverage and may result in costly water damage. Proper installation is the responsibility of the installer. Product failure or property damage due to improper installation is not covered under warranty.

Hoshizaki provides this manual primarily to assist qualified service technicians in the installation, maintenance, and service of the icemaker.

Should the reader have any questions or concerns which have not been satisfactorily addressed, please call, send an e-mail message, or write to the Hoshizaki Technical Support Department for assistance.

Phone: 1-800-233-1940; (770) 487-2331

Fax: 1-800-843-1056; (770) 487-3360

E-mail: techsupport@hoshizaki.com

HOSHIZAKI AMERICA, INC.

618 Highway 74 South

Peachtree City, GA 30269

Attn: Hoshizaki Technical Support Department

NOTE: To expedite assistance, all correspondence/communication **MUST** include the following information:

- Model Number _____
- Serial Number _____
- Complete and detailed explanation of the problem.

IMPORTANT

This manual should be read carefully before the icemaker is installed and operated. Read the warnings and guidelines contained in this booklet carefully as they provide essential information for the continued safe use and maintenance of the icemaker. Retain this booklet for any further reference that may be necessary.

CONTENTS

Important Safety Information	4
I. Specifications.....	6
A. Electrical and Refrigerant Data	6
1. KMS-1401MLJ.....	6
2. SRK-14J	7
3. SRK-14J3	8
B. Dimensions/Connections	9
1. KMS-1401MLJ.....	9
2. SRK-14J/3	10
II. Installation and Operating Instructions	11
A. Location	11
1. Icemaker	11
2. Remote Condensing Unit.....	12
B. Checks Before Installation.....	13
1. Icemaker	13
2. Remote Condensing Unit.....	13
C. How to Remove Panels	14
1. Icemaker	14
2. Remote Condensing Unit.....	14
D. Installation of the Icemaker	15
1. Setup.....	15
2. Water Tank Removal	17
3. Bin Control Installation.....	19
E. Installation of the Remote Condensing Unit.....	21
1. Setup.....	21
2. Line Set	21
a) Factory Line Set Installation	23
b) Field Fabricated Line Set Installation.....	24
F. Electrical Connection	26
G. Water Supply and Drain Connections	29
H. Final Checklist.....	31
I. Startup.....	32
III. Cleaning and Maintenance	34
A. Cleaning and Sanitizing Instructions.....	34
1. Cleaning Procedure.....	35
2. Sanitizing Procedure - Following Cleaning Procedure	36
B. Maintenance.....	37
C. Preparing the Icemaker for Periods of Non-Use.....	38

Important Safety Information

Throughout this manual, notices appear to bring your attention to situations which could result in death, serious injury, damage to the unit, or damage to property.

⚠ WARNING Indicates a hazardous situation which could result in death or serious injury.

NOTICE Indicates a situation which could result in damage to the unit or property.

IMPORTANT Indicates important information about the installation, use, and care of the unit.

⚠ WARNING

This icemaker should be destined only to the use for which it has been expressly conceived. Any other use should be considered improper and therefore dangerous. The manufacturer cannot be held responsible for injury or damage resulting from improper, incorrect, and unreasonable use. Failure to install, operate, and maintain the equipment in accordance with this manual will adversely affect safety, performance, component life, and warranty coverage and may result in costly water damage.

To reduce the risk of death, electric shock, serious injury, or fire, follow basic precautions including the following:

- Only qualified service technicians should install and service the icemaker.
- Move the control switch to the "OFF" position and turn off the power supply to the remote condensing unit before servicing. Place the icemaker disconnect (if applicable) in the "OFF" position. Lockout/Tagout to prevent the power supply from being turned back on inadvertently.
- This icemaker must be installed in accordance with applicable national, state, and local codes and regulations.
- To reduce the risk of electric shock, do not touch the control switch or service switch with damp hands.
- Do not make any alterations to the unit. Alterations could result in electric shock, injury, fire, or damage to the unit.
- This appliance is not intended for use by persons (including children) with reduced physical, sensory, or mental capabilities, or lack of experience and knowledge, unless they have been given supervision or instruction concerning use of the appliance by a person responsible for their safety.
- Young children should be properly supervised around this appliance.
- Do not climb, stand, or hang on the icemaker or allow children or animals to do so. Serious injury could occur or the icemaker could be damaged.
- Do not use combustible spray or place volatile or flammable substances near the unit. They might catch fire.
- Keep the area around the unit clean. Dirt, dust, or insects in the unit could cause harm to individuals or damage to the equipment.

⚠ WARNING, continued

Icemaker

- Do not connect the icemaker to an external power source. Icemaker power supply and ground connection are supplied from the remote condensing unit via the wire bundle provided with the remote condensing unit.
- Wire bundle routing (conduit) and disconnect (if required) must meet national, state, and local electrical code requirements. Failure to meet these code requirements could result in death, electric shock, serious injury, fire, or damage.
- **THE ICEMAKER MUST BE GROUNDED.** Failure to properly ground the icemaker could result in death or serious injury.

Remote Condensing Unit

- Remote condensing unit electrical connection must be hard-wired and must meet national, state, and local electrical code requirements. Failure to meet these code requirements could result in death, electric shock, serious injury, fire, or damage.
- The remote condensing unit requires an independent power supply of proper capacity. See the nameplate for electrical specifications. Failure to use an independent power supply of proper capacity can result in a tripped breaker, blown fuse, damage to existing wiring, or component failure. This could lead to heat generation or fire.
- **THE REMOTE CONDENSING UNIT MUST BE GROUNDED.** Failure to properly ground the remote condensing unit could result in death or serious injury.

NOTICE

- Follow the water supply, drain connection, and maintenance instructions carefully to reduce the risk of costly water damage.
- In areas where water damage is a concern, install in a contained area with a floor drain.
- Install the icemaker in a location that stays above freezing. Normal operating ambient temperature must be within 45°F to 100°F (7°C to 38°C).
- Do not leave the icemaker on during extended periods of non-use, extended absences, or in sub-freezing temperatures. To properly prepare the icemaker for these occasions, follow the instructions in "III.C. Preparing the Icemaker for Periods of Non-Use."
- Do not place objects on top of the appliance.
- The dispenser unit/ice storage bin is for ice use only. Do not store anything else in the dispenser unit/ice storage bin.

I. Specifications

A. Electrical and Refrigerant Data

1. KMS-1401MLJ

HOSHIZAKI ICE MAKER	
MODEL NUMBER	KMS-1401MLJ
SERIAL NUMBER	
AC SUPPLY VOLTAGE	115-120/60/1
PUMP	120V 1.2FLA 60W
OTHER	115V 0.8A
DESIGN PRESSURE	HI-467PSI LO-230PSI
TOTAL REFRIGERANT CHARGE WITH HOSHIZAKI CONDENSING UNIT SRK-14J, SRK-14J3	404A 16 LB. 5 OZ.

NOT INTENDED FOR OUTDOOR USE!
WARNING! Power supplied from remote condensing unit.
To reduce the risk of death, electric shock, serious injury, or fire, turn off the remote condensing unit power supply before servicing. Lockout/Tagout to prevent the power supply from being turned back on inadvertently.

Hoshizaki America, Inc.
Peachtree City, GA
www.hoshizaki.com

For certification marks, see the nameplate on the rear panel.

The rating label and nameplate provide electrical and refrigerant data. The rating label can be seen by removing the front panel. The nameplate is located on the rear panel.

IMPORTANT
This icemaker is designed for connection to Hoshizaki Remote Condensing Unit Model SRK-14J/3 only! CONNECTION TO ANOTHER REMOTE CONDENSING UNIT WILL VOID WARRANTY.

We reserve the right to make changes in specifications and design without prior notice.

2. SRK-14J

HOSHIZAKI CONDENSING UNIT

MODEL NUMBER	SRK-14J
SERIAL NUMBER	
AC SUPPLY VOLTAGE	208-230/60/1 (3 WIRE WITH NEUTRAL FOR 115V)
COMPRESSOR	230V 10.1RLA 65.5LRA
FAN	115V 2.6FLA (total) 126W
OTHER	115V 0.4A
MAXIMUM FUSE SIZE	20 AMPS
MAX. HACR BREAKER (USA ONLY)	20 AMPS
MAX. CIRC. BREAKER (CANADA ONLY)	20 AMPS
MINIMUM CIRCUIT AMPACITY	20 AMPS
DESIGN PRESSURE	HI-467PSI LO-230PSI
REFRIGERANT	404A 16 LB. 5 OZ.

**MOTOR-COMPRESSOR THERMALLY PROTECTED
FOR OUTDOOR USE**

Hoshizaki America, Inc.
Peachtree City, GA
www.hoshizaki.com

**For certification marks, see the nameplate
on the condensing unit.**

The nameplate provides electrical and refrigerant data. The nameplate is located on the remote condensing unit.

We reserve the right to make changes in specifications and design without prior notice.

3. SRK-14J3

HOSHIZAKI CONDENSING UNIT

MODEL NUMBER	SRK-14J3
SERIAL NUMBER	
AC SUPPLY VOLTAGE	208-230/60/3
COMPRESSOR	230V 8.0RLA 82.0LRA
FAN	115V 2.6FLA (total) 126W
OTHER	115V 0.4A
MAXIMUM FUSE SIZE	20 AMPS
MAX. HACR BREAKER (USA ONLY)	20 AMPS
MAX. CIRC. BREAKER (CANADA ONLY)	20 AMPS
MINIMUM CIRCUIT AMPACITY	20 AMPS
DESIGN PRESSURE	HI-467PSI LO-230PSI
REFRIGERANT	404A 16 LB. 5 OZ.

**MOTOR-COMPRESSOR THERMALLY PROTECTED
FOR OUTDOOR USE**

Hoshizaki America, Inc.
Peachtree City, GA
www.hoshizaki.com

**For certification marks, see the nameplate
on the condensing unit.**

The nameplate provides electrical and refrigerant data. The nameplate is located on the remote condensing unit.

We reserve the right to make changes in specifications and design without prior notice.

B. Dimensions/Connections

1. KMS-1401MLJ

Unit: mm [in.]

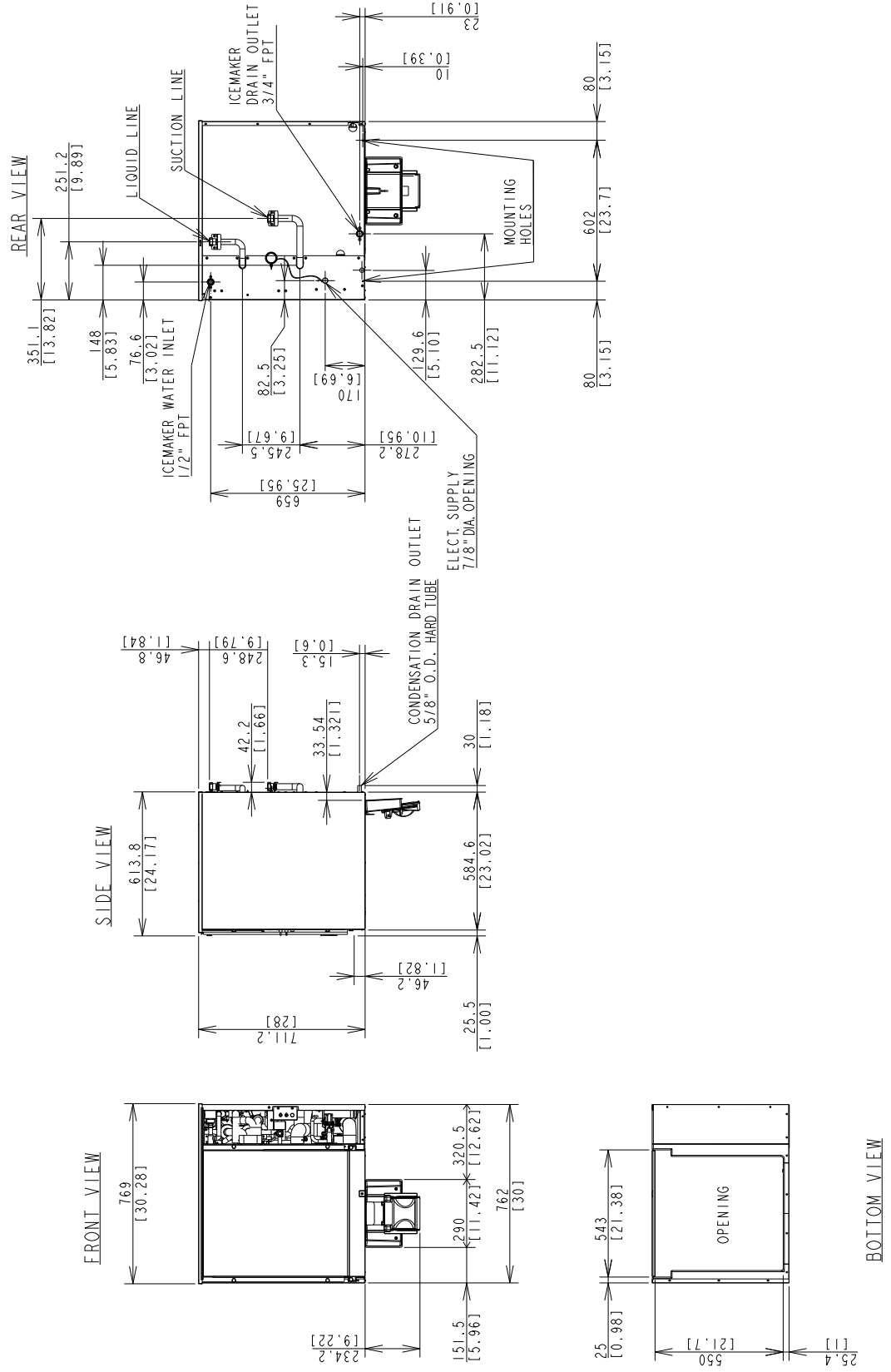

2. SRK-14J/3

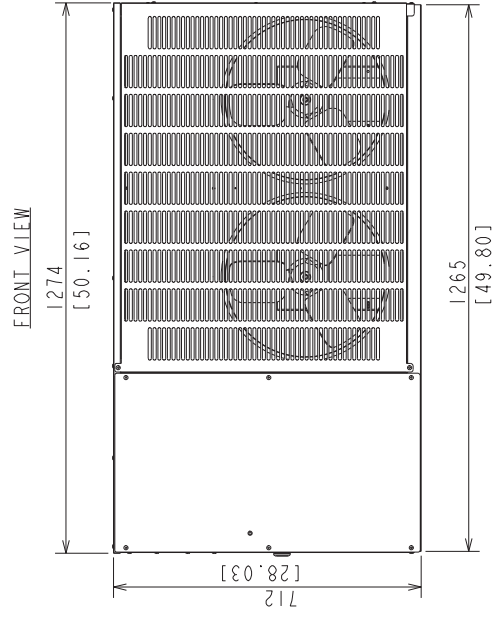
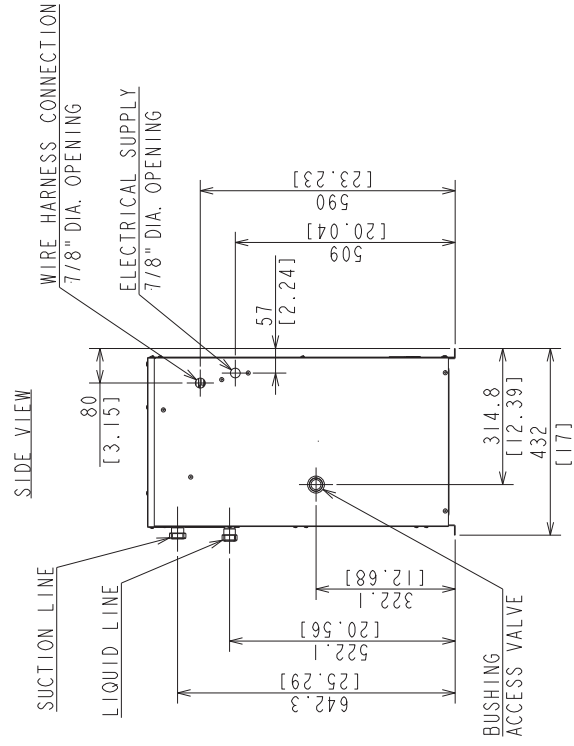
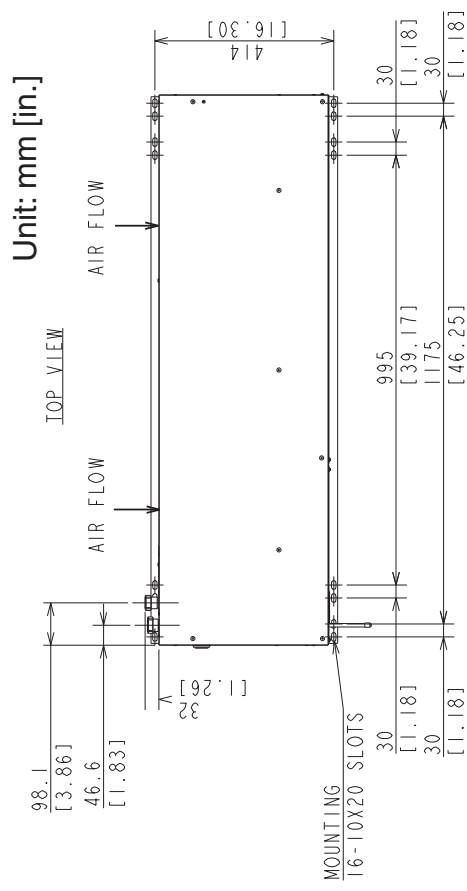

Note: Legs are included with remote condensing unit.
Leg height is 380 mm (14.96 in.).

II. Installation and Operating Instructions

⚠ WARNING

- The icemaker and remote condensing unit must be installed in accordance with applicable national, state, and local codes and regulations.
- Failure to install, operate, and maintain the equipment in accordance with this manual will adversely affect safety, performance, component life, and warranty coverage and may result in costly water damage.
- **CHOKING HAZARD:** Ensure all components, fasteners, and thumbscrews are securely in place after installation. Make sure that none have fallen into the dispenser unit/storage bin.

A. Location

1. Icemaker

NOTICE

- This icemaker is not intended for outdoor use. Normal operating ambient temperature must be within 45°F to 100°F (7°C to 38°C); Normal operating water temperature must be within 45°F to 90°F (7°C to 32°C). Operation of the icemaker, for extended periods, outside of these normal temperature ranges may affect icemaker performance.
- This icemaker will not work at sub-freezing temperatures. To prevent damage to the water supply line, drain the icemaker if the air temperature is going to go below 32°F (0°C). See "III.C. Preparing the Icemaker for Periods of Non-Use."

- The icemaker should not be located next to ovens, grills, or other high heat producing equipment.
- There is no minimum clearance required for proper operation.
- The location must provide a firm and level foundation for the equipment.

2. Remote Condensing Unit

NOTICE

The remote condensing unit is intended for outdoor use. Normal operating ambient temperature must be within -20°F to 122°F (-29°C to 50°C). Operation of the remote condensing unit, for extended periods, outside of this normal temperature range may affect icemaker performance.

The icemaker must be coupled with the appropriate remote condensing unit as listed below.

Hoshizaki Icemaker	Hoshizaki Remote Condensing Unit
KMS-1401MLJ	SRK-14J/3

NOTICE

Failure to install the equipment within these guidelines may adversely affect performance, component life, and warranty coverage.

The remote condensing unit must be positioned in a permanent site under the following guidelines:

- A firm and flat site.
- A dry and well ventilated area with 24" (61 cm) clearance in both front and rear for proper air circulation and ease of maintenance and/or service should they be required. See Fig. 1.
- The maximum line set length is 66 feet.
- The maximum vertical distance between the remote condensing unit and icemaker is 33 feet above or 10 feet below the icemaker. These distances are measured fitting to fitting. See Fig. 2.
- If the vertical distance between the remote condensing unit and the icemaker is greater than 20 feet (not to exceed 33 feet), an "S" oil-trap (5/8" OD copper tubing) must be installed in the suction line. The "S" oil-trap must be located halfway between the icemaker and remote condensing unit. This ensures sufficient oil return to the compressor.

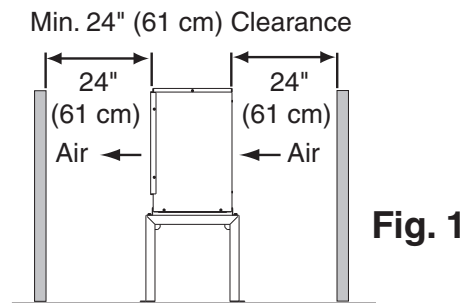

Fig. 1

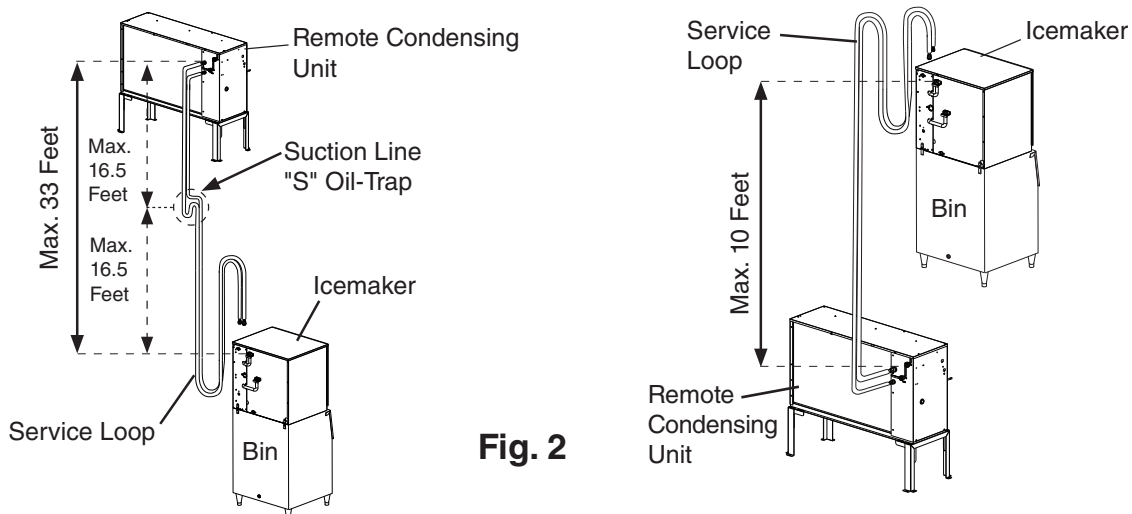

Fig. 2

B. Checks Before Installation

- Visually inspect the exterior of the shipping containers and immediately report any damage to the carrier. Upon opening the containers, any concealed damage should also be immediately reported to the carrier.
- Remove the shipping carton, tape, and packing material. If any are left in the icemaker or remote condensing unit, they will not work properly.

1. Icemaker

- Remove the panels to prevent damage when installing the icemaker. See "II.C. How to Remove Panels."
- Remove the package containing the accessories.
- Remove the protective plastic film from the panels. If the icemaker is exposed to the sun or to heat, remove the film after the icemaker cools.
- Check that the refrigerant lines do not rub or touch lines or other surfaces.
- This icemaker can be installed on a dispenser unit or storage bin 30" wide or wider. For options, contact your local Hoshizaki distributor.
- **This icemaker is designed for connection to Hoshizaki Remote Condensing Unit Model SRK-14J/3 only! CONNECTION TO ANOTHER REMOTE CONDENSING UNIT WILL VOID WARRANTY.**

2. Remote Condensing Unit

- See the nameplate on the remote condensing unit. Check that your voltage supplied corresponds with the voltage specified on the nameplate.
- Remove the panels to prevent damage when installing the remote condensing unit. See "II.C. How to Remove Panels."
- Remove the package containing the accessories.
- Check that the refrigerant lines do not rub or touch lines or other surfaces, and that the fan blades turn freely.
- Check that the compressor is snug on all mounting pads.

C. How to Remove Panels

1. Icemaker

- Front Panel: Remove the screw. Lift up and towards you.
- Top Panel: Lift off.
- Right Side Panel: Remove the screw. Slide forward slightly and lift off.
- Front Frame: Remove the thumbscrews and lift off.
- Insulation Panel: Remove the thumbscrews. Lift up slightly and pull towards you.
- Top Insulation: Lift off.

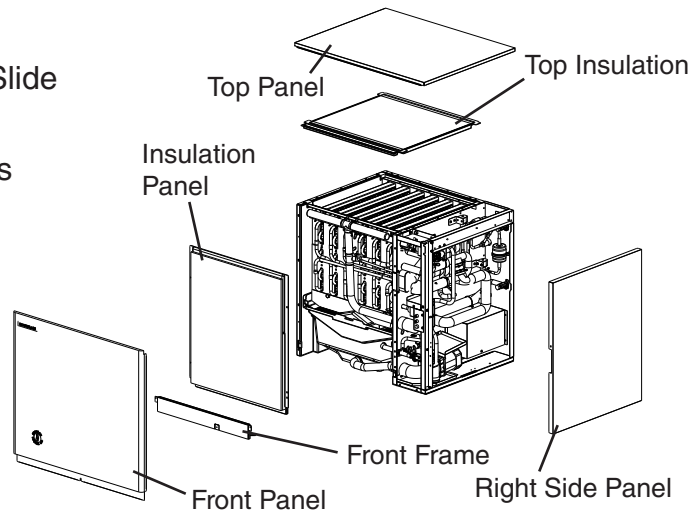

Icemaker

Fig. 3

2. Remote Condensing Unit

- Top Panel: Remove the screws and lift off.
- Front Panel: Remove the screws and lift off.
- Rear Panel: Remove the screws and lift off.
- Left Side/Rear Panel: Remove the screws and lift off.
- Louver Panel: Remove the screws and lift off.
- Right Side Panel: Remove the screws and lift off.

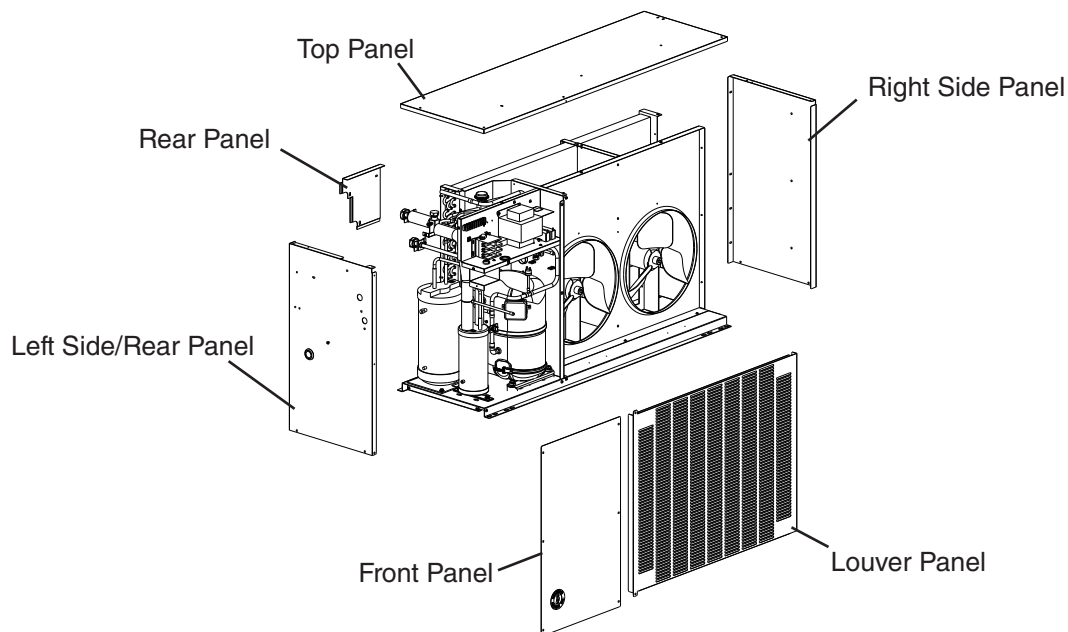

Remote Condensing Unit

Fig. 4

D. Installation of the Icemaker

NOTICE

- Do not connect the icemaker to an external power source. Icemaker power supply and ground connection are supplied from the remote condensing unit via the wire bundle provided with the remote condensing unit. For details, see "II.F. Electrical Connection."
- Before operating the icemaker, the bin control must be installed correctly. Failure to properly install the bin control could result in ice backup and unit damage.
- Failure to properly seal the icemaker to the dispenser unit/storage bin could result in water leakage and costly water damage.

1. Setup

- 1) If mounting the icemaker on top of a dispenser unit, follow the dispenser unit's setup procedure. If mounting the icemaker on top of a storage bin, unpack the storage bin and attach the 4 adjustable legs provided (bin accessory) to the bottom of the storage bin.
- 2) Position the dispenser unit/storage bin in its permanent location.
- 3a) **Dispenser Unit:** Install the dispenser unit adapter kit. Make sure the dispenser unit adapter kit opening and the icemaker water tank opening match. If not, cut the dispenser unit adapter kit to the dimensions needed to match the icemaker water tank opening. **WARNING! The dispenser unit adapter kit opening MUST match the icemaker water tank opening. A smaller opening may result in water leakage which could create a slip hazard or costly water damage. Seal the adapter kit to the dispenser unit with RTV-748 sealant (provided) or equivalent.** See Fig. 5.

Dispenser Unit Application

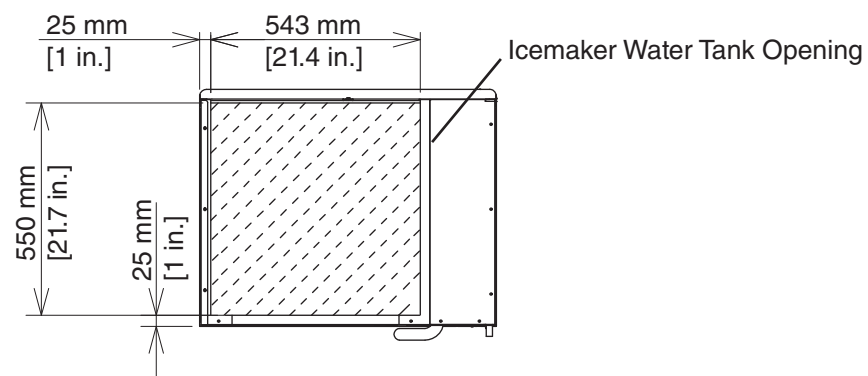

Fig. 5

- 3b) **Storage Bin:** If required, install a top kit, a storage bin extension bracket HS kit, or a brace HS kit. Contact your local Hoshizaki distributor for recommendations.
- 4) Place the icemaker on top of the dispenser unit/storage bin.

- 5a) **Dispenser Unit:** Follow the dispenser unit's instructions for securing the icemaker to the dispenser unit. If no instructions are available, secure the icemaker to the dispenser unit using the mounting brackets provided. Rotate the mounting brackets so that they fit flush to the dispensing unit. See Fig. 6a. Secure the mounting brackets to the icemaker with the bolts provided. Secure the mounting brackets to the dispensing unit with self-tapping screws (not provided). **NOTICE! Use care to avoid damage to the dispenser unit components when attaching the mounting brackets.** Seal the outer perimeter of the icemaker to the dispenser unit with RTV-748 sealant (provided) or equivalent.
- 5b) **Storage Bin:** Secure the icemaker to the storage bin using the 2 mounting brackets and the bolts provided. See Fig. 6b. Seal the outer perimeter of the icemaker to the storage bin with RTV-748 sealant (provided) or equivalent.
- 6) Level the icemaker and dispensing unit/storage bin in both the left-to-right and front-to-rear directions. If using a storage bin, adjust the storage bin legs to make the icemaker level.

Dispenser Unit Application

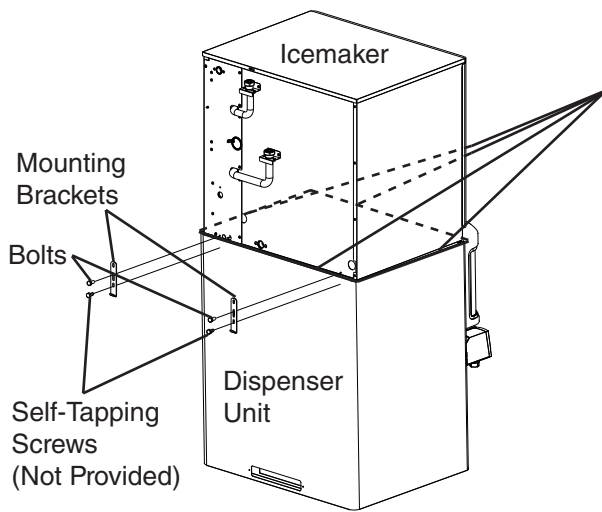

Fig. 6a

Storage Bin Application

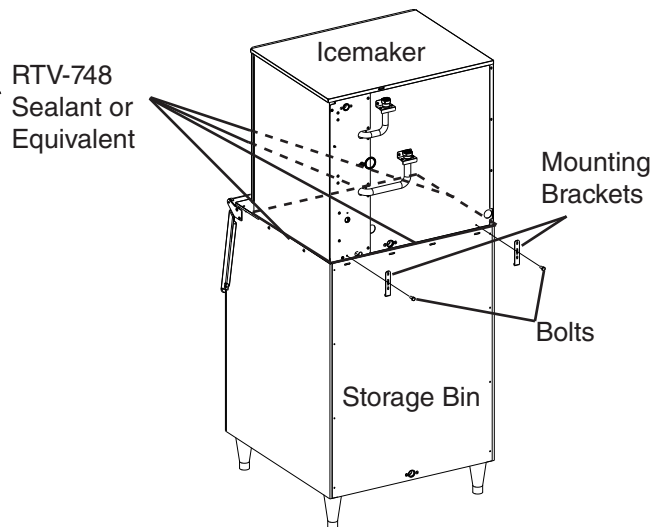

Fig. 6b

2. Water Tank Removal

- 1) Remove the 2 thumbscrews securing the splash curtain, then remove the splash curtain. See Fig. 7.
- 2) Disconnect the pump suction hose, drain pipe, and float connection hose at the evaporator case wall. Disconnect the water tank drain hose from the bottom of the water tank. Although the water tank can be removed at this point, do not remove it yet because the bin control is taped inside the water tank.

NOTICE

The bin control cable is routed through the back of the icemaker. If care is not taken when removing the water tank, the bin control cable could be severed.

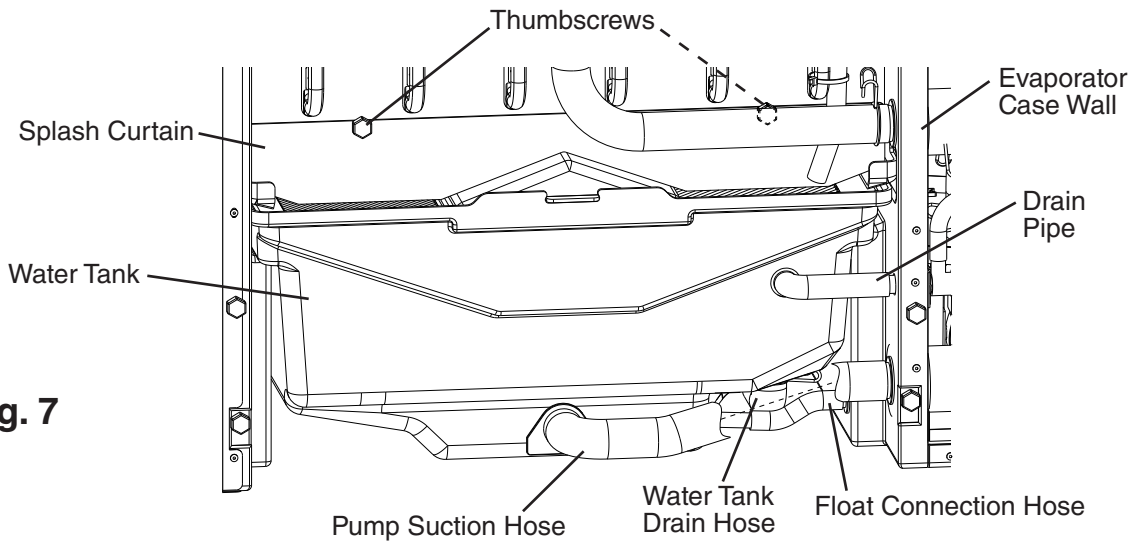

Fig. 7

- 3) Pull out the water tank only as far as shown in Fig. 8.
- 4) Remove the cube guide, then remove the bin control assembly.
- 5) **Being careful not to pull the bin control cable**, remove the water tank completely from the icemaker.
- 6) Remove the remaining pieces of tape from the water tank and leave the water tank out of the icemaker for now.

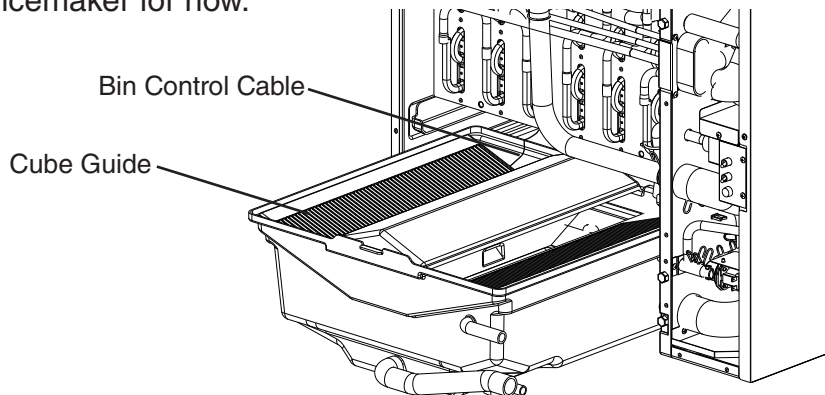

Fig. 8

7) **Dispenser Unit:** Seal the inside perimeter of the icemaker evaporator section to the dispenser unit adapter kit with RTV-748 sealant (provided) or equivalent. See Fig. 9.

⚠ WARNING

The following locations must be properly sealed with RTV-748 sealant or equivalent. Otherwise, water leakage may occur which could result in a slip hazard and costly water damage.

- Contact points between the dispenser unit and the dispenser unit adapter kit.
- Contact points between the icemaker evaporator section and the dispenser unit adapter kit.
- Outer perimeter contact points between the dispenser unit and icemaker.

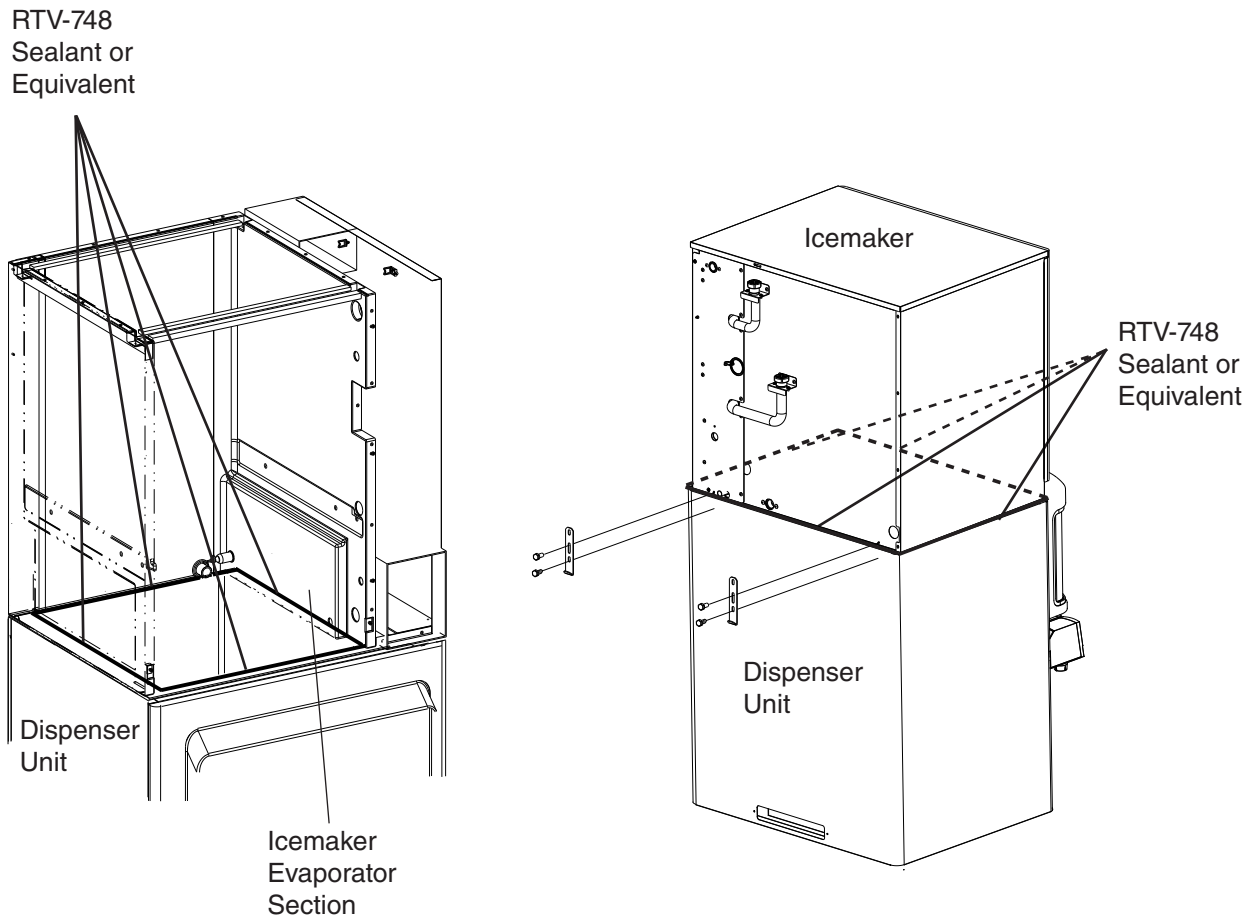

Fig. 9

3. Bin Control Installation

NOTICE

Before operating the icemaker, the bin control assembly must be installed correctly. Failure to properly install the bin control assembly could result in ice backup and unit damage.

- 1) Remove the 2 outer switch cover thumbscrews from the switch cover. See Fig. 10.
- 2) Remove the 2 inner switch cover thumbscrews. Remove the bin control from the switch mount.
- 3) Mount the bin control to the extension bracket (accessory bag) using the 2 thumbscrews from the accessory bag. Route the bin control cable from the outer corner of the bin control up through the gap in the extension bracket.
- 4) Using the 2 thumbscrews removed in step 2, mount the extension bracket to the switch cover.
- 5) Replace the outer switch cover thumbscrews into the slots on the switch bracket. Do not tighten.

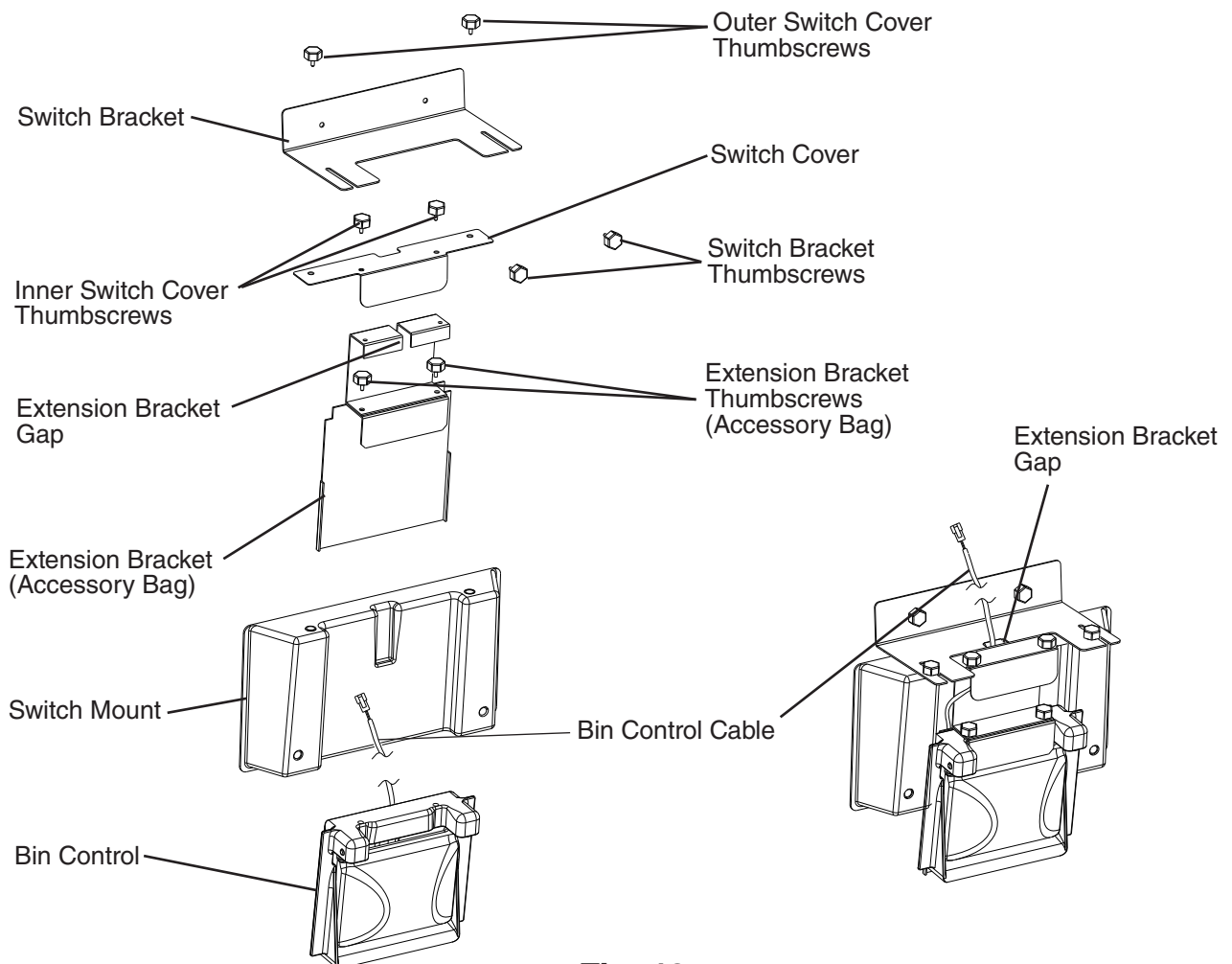
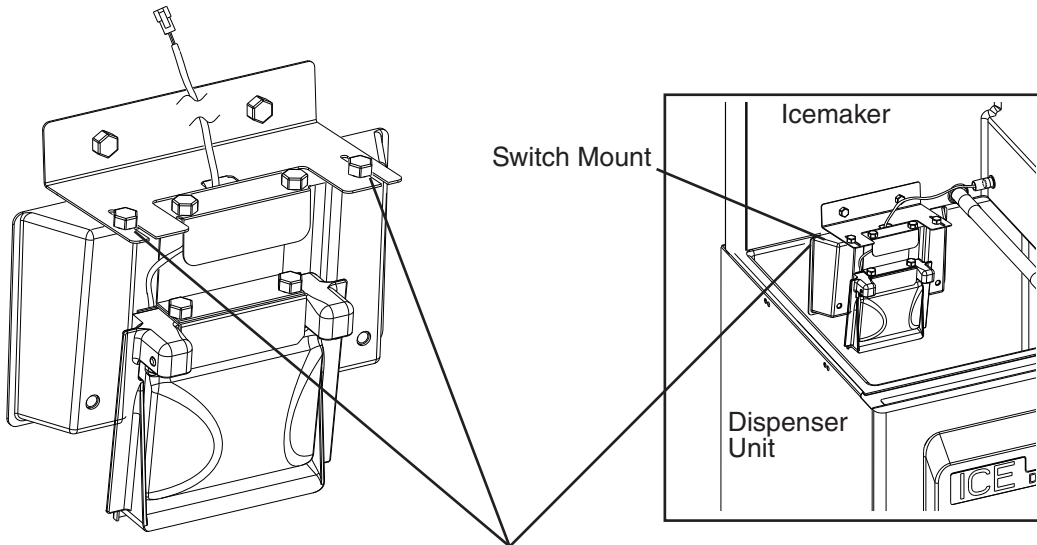

Fig. 10

- 6) Slide the bin control assembly all the way back until the switch mount is flush with the dispenser unit bin wall or the storage bin wall, top kit extension bracket, or brace. See Fig. 11. Tighten the outer switch cover thumbscrews.

NOTICE

On dispenser unit applications, do not leave a gap between the bin control and the wall of the dispenser unit bin wall. If a gap is left between the bin control and the wall of the dispenser unit bin wall, ice may get between them and damage the bin control.



Dispenser Unit: Slide the bin control assembly all the way back until the switch mount is flush with the dispenser unit bin wall.

Storage Bin: Slide the bin control assembly all the way back until the switch mount is flush with the storage bin wall, top kit extension bracket, or brace.

Fig. 11

- 7) Pull the bin control cable so that there is no slack in the ice drop area, then secure the hose that the bin control cable runs through with a cable tie. See Fig. 12.

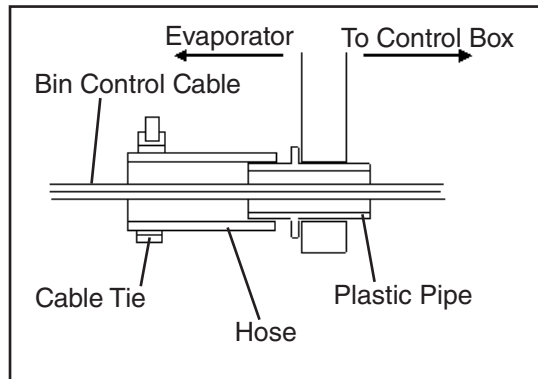

Fig. 12

- 8) Replace the water tank in the icemaker and reconnect the 4 hoses.
 Note: The panels, front frame, and splash curtain are replaced during "II.I. Startup."

E. Installation of the Remote Condensing Unit

⚠ WARNING

- Installation must be performed by properly trained and EPA-certified service personnel.
- Power supply and ground wire to the icemaker are supplied from the remote condensing unit. For details, see "II.F. Electrical Connection."

1. Setup

- 1) Secure the legs to the remote condensing unit with the 16 bolts and nuts provided. See Fig. 13.
- 2) The legs have 8 mounting holes. Secure the legs with 8 bolts (not included).

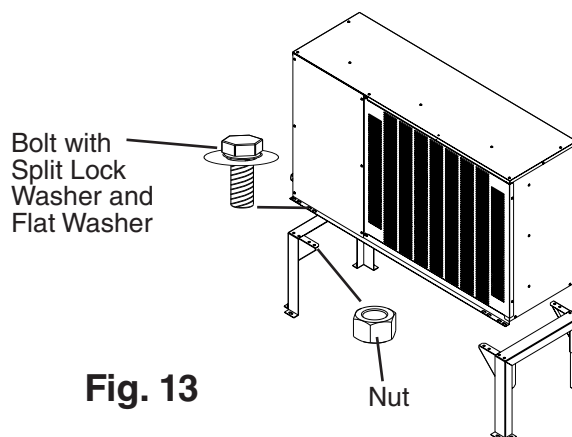

Fig. 13

2. Line Set

NOTICE

The icemaker, remote condensing unit, and line set must contain the same type of refrigerant. Mixing of refrigerants will result in improper operation and possible damage to equipment.

- The maximum line set length is 66 feet and no refrigerant charge adjustment is necessary. **NOTICE! Do not exceed maximum line set length.**

Line Set Size and Length for SRK-14J/3 Remote Condensing Units				
Model	Liquid Line	Suction Line	Factory Line Set Lengths (ft)	Maximum Line Set Length (ft)
KMS-1401MLJ	1/2" OD	5/8" OD	20, 35, and 55	66

- Precharged factory line sets, available as optional equipment from Hoshizaki America, are recommended. For details see "II.E.2.a) Factory Line Set Installation." Field fabricated line sets are allowed. For details, see "II.E.2.b) Field Fabricated Line Set Installation."
- The maximum vertical distance between the remote condensing unit and icemaker is 33 feet above or 10 feet below the icemaker. These distances are measured fitting to fitting. See Fig. 14. **NOTICE! Do not exceed maximum vertical distance.**
- If the vertical distance between the remote condensing unit and the icemaker is greater than 20 feet (not to exceed 33 feet), an "S" oil-trap (5/8" OD tubing) must be installed in the suction line. The "S" oil-trap must be located halfway between the icemaker and remote condensing unit. This ensures sufficient oil return to the compressor.

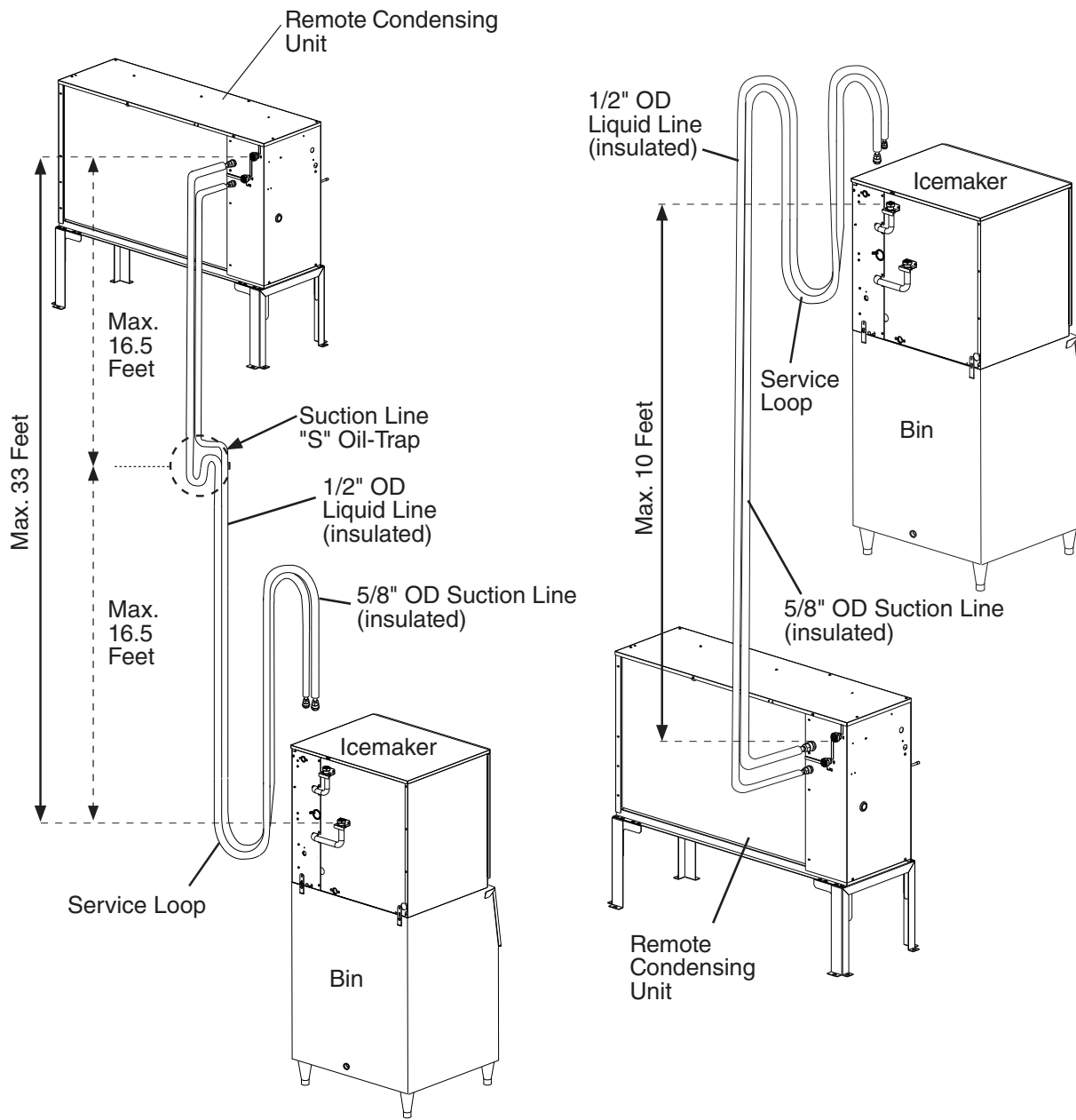

Fig. 14

a) *Factory Line Set Installation*

- 1) Route the factory line set (5/8" OD suction line and 1/2" OD liquid line) from the remote condensing unit to the icemaker. Leave a service loop behind the icemaker to allow the icemaker to be pulled out for service. See Fig. 14. Factory fabricated line sets are precharged and do not need to be evacuated. If the line set is too long or too short, see "II.E.2.a)(1) Factory Line Set Modification."

NOTICE
<ul style="list-style-type: none">• Ensure that there are no traps and no kinks in the line set. The service loop is not considered an oil trap.• Do not coil extra line set.

- 2) Connect the refrigerant lines to the appropriate male fittings on the icemaker first and then at the remote condensing unit. Make a proper connection as follows:
 - a. Remove the protective covers from the male fitting and female coupling.
 - b. Apply Polyol Ester (POE) refrigerant oil or Parker Super O Lube to the entire male fitting, including O-ring, diaphragm, and threads before making the connection. See Fig. 15.

NOTICE
Do not use thread sealant on the fittings. Use POE refrigerant oil or Parker Super O Lube only.

- c. Make sure the male fitting and female coupling are properly aligned, then start the connection by hand to ensure that it is not cross threaded.
 - d. Tighten the connection with a wrench until it is tight. At this point, the nut has covered most of the threads on the male fitting.
 - e. Mark a reference line on the female coupling and the remote condensing unit or icemaker panel. Using a backup wrench on the back of the female coupling, tighten the six-sided nut of the female coupling an additional 1/6 turn. See Fig. 16.

(1) Factory Line Set Modification

- 1) Recover the line set charge through the Schrader access ports on the Parker quick connect couplings and store it in an approved container. Do not discharge the refrigerant into the atmosphere. Remove the extra line set length or add extra tubing. When adding extra tubing, insulate the additional copper tubes separately. Braze the connections.
- 2) Use an electronic leak detector or soap bubbles to check for leaks. Add a trace of refrigerant to the lines through the Schrader access ports on the Parker quick connect couplings (if using an electronic leak detector), and then raise the pressure using nitrogen gas (140 PSIG). **WARNING! Do not use R-404A as a mixture with pressurized air for leak testing.**
- 3) Evacuate through the Schrader access ports on the Parker quick connect couplings and charge with R-404A refrigerant vapor to a pressure of 15 to 30 PSIG. Go to step 2 in "II.E.2.a) Factory Line Set Installation."

b) Field Fabricated Line Set Installation

- 1) Route a 5/8" OD copper tube suction line and a 1/2" OD copper tube liquid line between the remote condensing unit and the icemaker. Leave a service loop behind the icemaker to allow the icemaker to be pulled out for service. See Fig. 14.

NOTICE

- Ensure that there are no traps and no kinks in the line set. The service loop is not considered an oil trap.
- Do not coil extra line set. Fabricate the line set to the proper length.

- 2) Insulate the two copper tubes separately.
- 3) Install Parker quick connect couplings on each end. OS-Quick, a universal quick connect coupling kit available as optional equipment from Hoshizaki America, is recommended. **NOTICE! Before brazing, remove the Schrader valve core from the access port. When brazing, protect the coupling by using a wet cloth to prevent the coupling from overheating.**
- 4) Allow the coupling to cool, then replace the Schrader valve core.
- 5) Use an electronic leak detector or soap bubbles to check for leaks. Add a trace of refrigerant to the to the lines through the Schrader access ports on the Parker quick connect couplings (if using an electronic leak detector), and then raise the pressure using nitrogen gas (140 PSIG). **WARNING! Do not use R-404A as a mixture with pressurized air for leak testing.**
- 6) Evacuate through the Schrader access ports on the Parker quick connect couplings and charge with R-404A refrigerant vapor to a pressure of 15 to 30 PSIG.
- 7) Connect the refrigerant lines to the appropriate male fittings on the icemaker first and then at the remote condensing unit. Make a proper connection as follows:
 - a. Remove the protective covers from the male fitting and female coupling.
 - b. Apply Polyol Ester (POE) refrigerant oil or Parker Super O Lube to the entire male fitting, including O-ring, diaphragm, and threads before making the connection. See Fig. 15.

NOTICE

Do not use thread sealant on the fittings. Use POE refrigerant oil or Parker Super O Lube only.

- c. Make sure the male fitting and female coupling are properly aligned, then start the connection by hand to ensure that it is not cross threaded.
- d. Tighten the connection with a wrench until it is tight. At this point, the nut has covered most of the threads on the male fitting.
- e. Mark a reference line on the female coupling and the remote condensing unit or icemaker panel. Using a backup wrench on the back of the female coupling, tighten the six-sided nut of the female coupling an additional 1/6 turn. See Fig. 16.

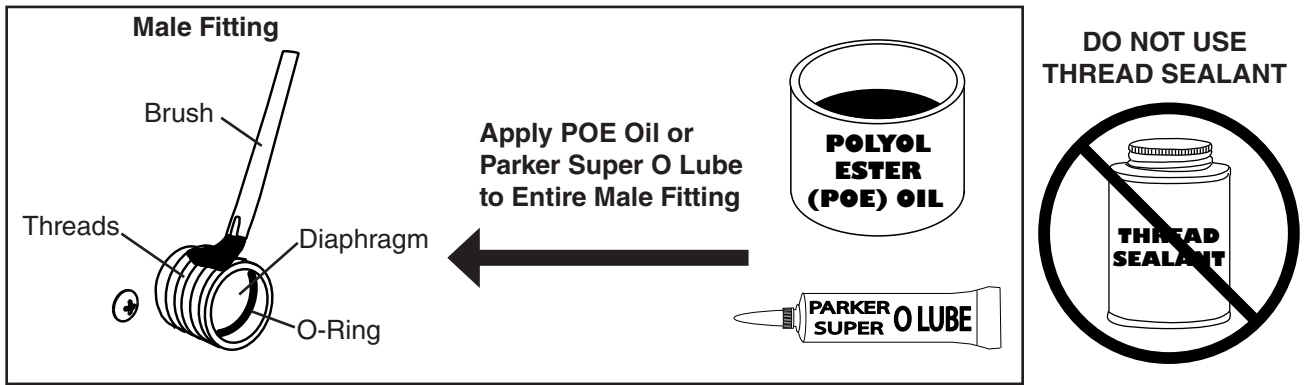

Fig. 15

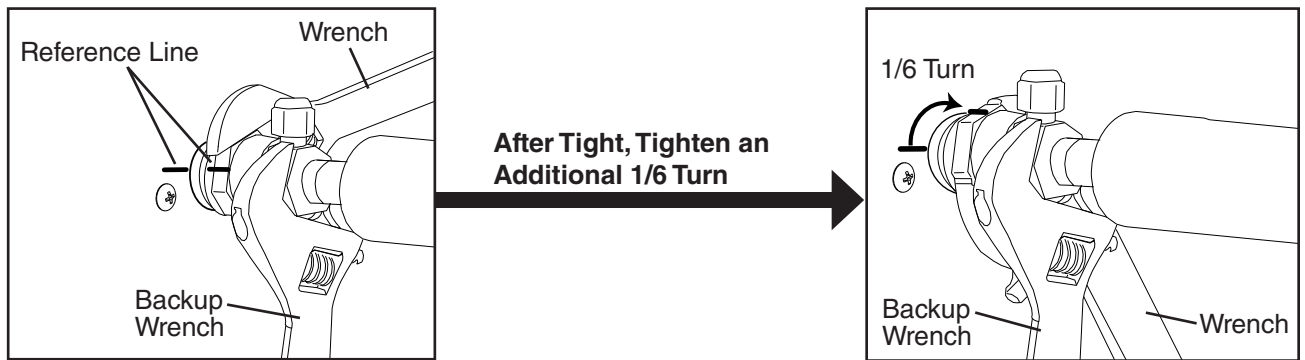

Fig. 16

F. Electrical Connection

⚠ WARNING

Icemaker

- Do not connect the icemaker to an external power source. Icemaker power supply and ground connection are supplied from the remote condensing unit via the wire bundle provided with the remote condensing unit.
- Wire bundle routing (conduit) and disconnect (if required) must meet national, state, and local electrical code requirements. If fabricating a wire bundle, use wire of an appropriate gage and outdoor rating. Failure to meet these code requirements could result in death, electric shock, serious injury, fire, or damage.
- **THE ICEMAKER MUST BE GROUNDED.** Failure to properly ground the icemaker could result in death or serious injury.
- To reduce the risk of electric shock, do not connect the remote condensing unit power supply until after all wire bundle connections have been made.

Remote Condensing Unit

- Remote condensing unit electrical connection must be hard-wired and must meet national, state, and local electrical code requirements. Failure to meet these code requirements could result in death, electric shock, serious injury, fire, or damage.
- The remote condensing unit requires an independent power supply of proper capacity. See the nameplate for electrical specifications. Failure to use an independent power supply of proper capacity can result in a tripped breaker, blown fuse, damage to existing wiring, or component failure. This could lead to heat generation or fire.
- **THE REMOTE CONDENSING UNIT MUST BE GROUNDED.** Failure to properly ground the remote condensing unit could result in death or serious injury.
- Remote condensing unit electrical connection must be made in accordance with the instructions on the "WARNING" tag provided with the pig tail leads in the remote condensing unit's power supply junction box. See Figs. 17a and 17b.

NOTICE

The remote condensing unit must have power for a minimum of 4 hours prior to startup to prevent compressor damage.

- Usually an electrical permit and services of a licensed electrician are required.
- The maximum allowable voltage variation is ± 10 percent of the nameplate rating.
- The openings for the power supply and wire bundle connections are 7/8" DIA to fit a 1/2" trade size conduit.

- 1) Route the wire bundle between the icemaker and remote condensing unit. Use the wire bundle supplied with the remote condensing unit, or fabricate a wire bundle using wire of an appropriate gage and outdoor rating. Use the wiring label or Fig. 18 as a reference.
- 2a) Icemaker: Connect the wire bundle ground wire to the icemaker ground screw, then connect the rest of the wire bundle wires to the icemaker terminal block.
WARNING! Do not connect the wire bundle ground wire to the icemaker terminal block.
- 2b) Remote Condensing Unit: Connect the wire bundle ground wire to the remote condensing unit ground screw (located next to the terminal block).
WARNING! Do not connect the wire bundle ground wire to the remote condensing unit terminal block.
- 3) Connect the power supply from the disconnect or electrical panel to the leads in the remote condensing unit's power supply junction box. This differs from KM style installations. Connect a ground wire to the ground screw. See Figs. 17a and 17b.
 - On single phase models, the white lead must be connected to the neutral conductor of the power source. **NOTICE! Miswiring may result in severe damage to the icemaker.**
 - On three phase models, the transformer's voltage tap switch must be positioned to match incoming voltage at startup.
 - **NOTICE! On three phase models, connect the highest incoming voltage supply ("stinger leg") to the power wire dedicated to the compressor. See the wiring label on the remote condensing unit.**
- 4) Replace all removed parts and panels in their correct positions.
- 5) Turn on the power supply to the remote condensing unit. **NOTICE! The remote condensing unit must have power for a minimum of 4 hours prior to startup to prevent compressor damage.**

SRK-14J

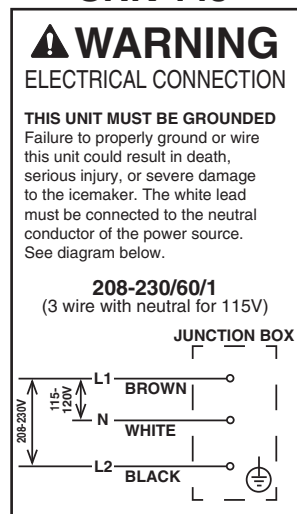

Fig. 17a

SRK-14J3

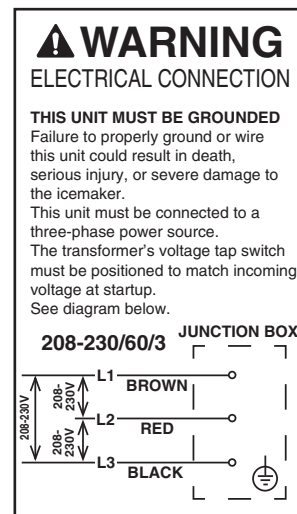
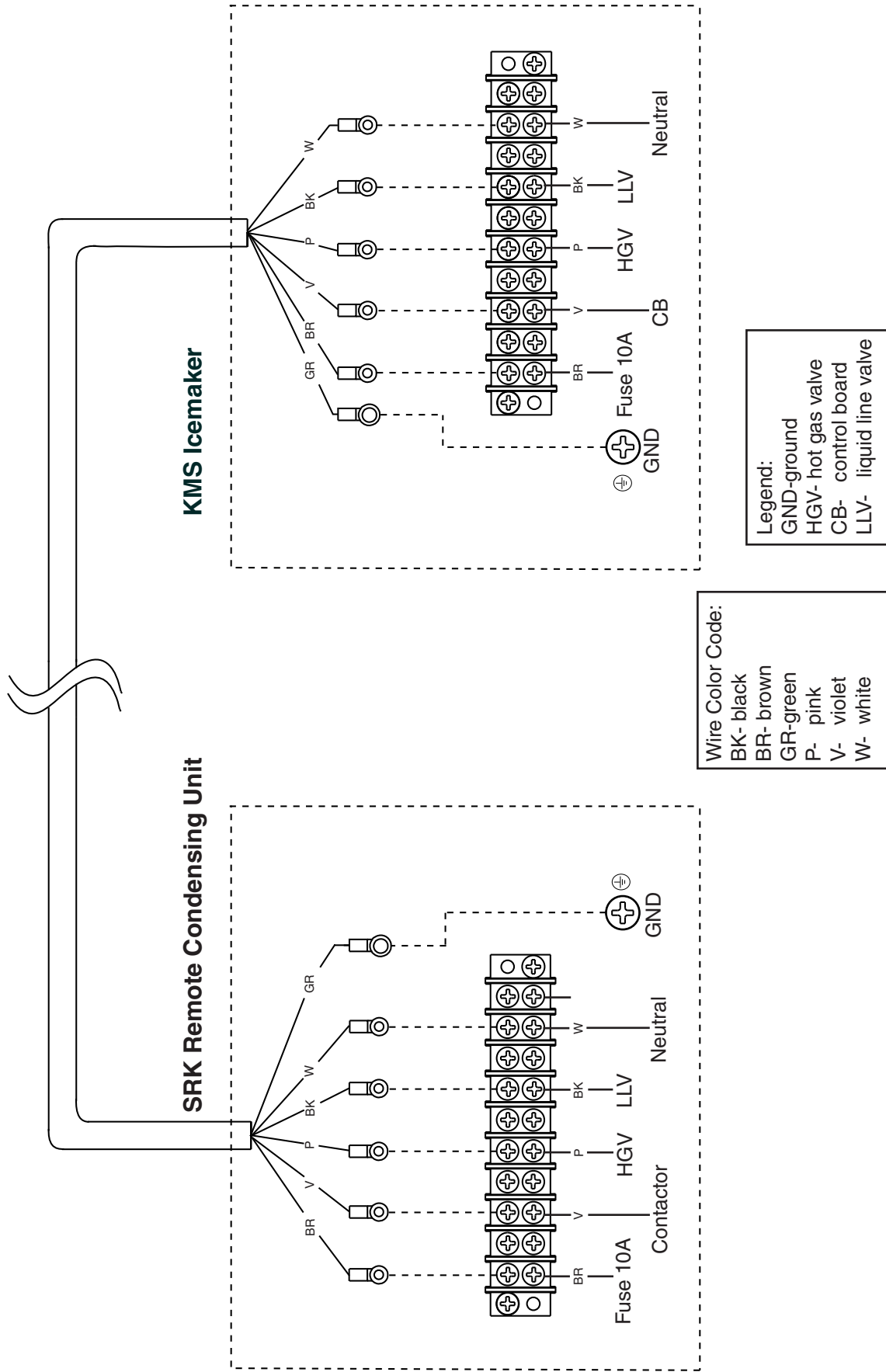

Fig. 17b

Icemaker-Remote Condensing Unit Wire Bundle Connections

Fig. 18

Use wire bundle supplied with the Remote Condensing Unit or fabricate a wire bundle using wire of an appropriate gage and outdoor rating.



G. Water Supply and Drain Connections

See Fig. 19

⚠ WARNING

Water supply and drain connections must be installed in accordance with applicable national, state, and local regulations.

NOTICE

- Normal operating water temperature should be within 45°F to 90°F (7°C to 32°C). Operation of the icemaker, for extended periods, outside of this normal temperature range may affect icemaker performance.
- To prevent damage to equipment, do not operate the icemaker when the water supply is off, or if the pressure is below 10 PSIG. Do not run the icemaker until the proper water pressure is reached.

- A plumbing permit and services of a licensed plumber may be required in some areas.
- External filters, strainers, or softeners may be required depending on water quality. Contact your local Hoshizaki Certified Service Representative for recommendations.
- Water supply pressure must be a minimum of 10 PSIG and a maximum of 113 PSIG. If the pressure exceeds 113 PSIG, the use of a pressure reducing valve is required.
- The icemaker and condensation drain line(s) and dispenser unit/storage bin drain line must be run separately.
- Drain lines must have 1/4" fall per foot (2 cm per 1 m) on horizontal runs to get a good flow. A vented tee connection is also required for proper flow.
- Drain lines should not be piped directly to the sewer system. An air gap of a minimum of 2 vertical inches (5 cm) should be between the end of the drain pipes from the icemaker, condensation drain, and dispenser unit/storage bin and the floor drain.

1. Icemaker

- Icemaker water supply inlet is 1/2" female pipe thread (FPT).
- A minimum of 3/8" nominal ID copper water tubing or equivalent is required for the icemaker water supply line. An icemaker water supply line shut-off valve and drain valve must be installed. Be sure there is sufficient extra water supply line for the unit to be pulled out for service.
- Icemaker drain outlet is 3/4" FPT. A minimum of 3/4" nominal ID hard pipe or equivalent is required for the icemaker drain line. Condensation drain outlet is 5/8" OD hard tube. The condensation drain line can be connected to the icemaker drain line or can be run separately. Be sure there is sufficient extra drain line for the unit to be pulled out for service.

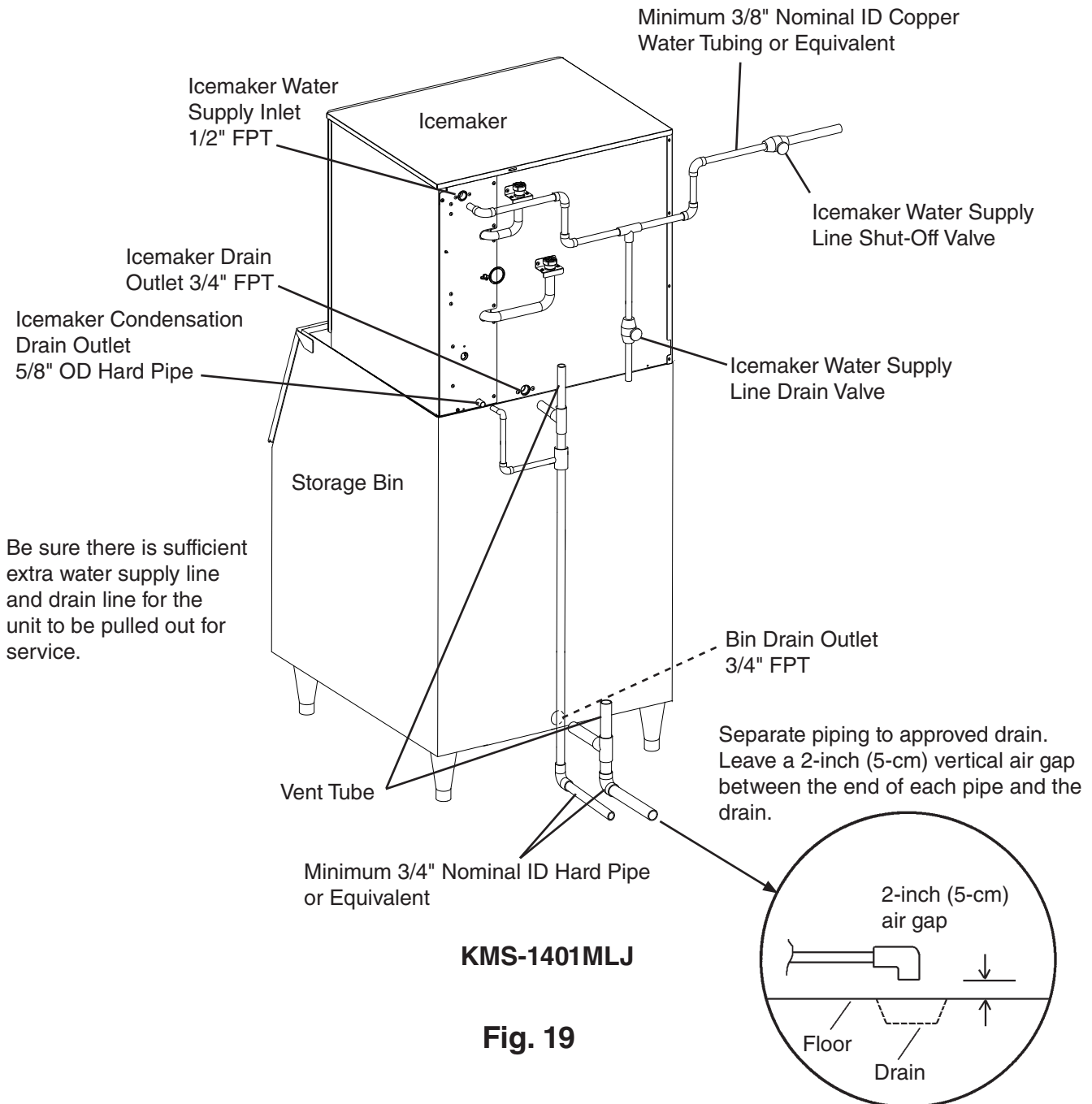

Fig. 19

H. Final Checklist

WARNING

CHOKING HAZARD: Ensure all components, fasteners, and thumbscrews are securely in place after installation. Make sure that none have fallen into the dispenser unit/storage bin.

- 1) Is the icemaker level?
- 2) Is the icemaker in a site where the ambient temperature is within 45°F to 100°F (7°C to 38°C) and the water temperature within 45°F to 90°F (7°C to 32°C) all year around?
- 3) Is there at least 24" (61 cm) clearance around the remote condensing unit for proper air circulation and ease of maintenance and service?
- 4) Have the shipping carton, tape, and packing material been removed from the icemaker and remote condensing unit? Are the cube guides and tank separator in their correct positions?
- 5) Have all water tank hoses been reconnected after installing the bin control?
Note: On dispenser unit applications, confirm that there is no gap between the switch mount and the dispenser unit bin wall. On storage bins, make sure there is no gap between the switch mount and the storage bin wall, top kit extension bracket, or brace.
- 6) Have all required areas been properly sealed with RTV-748 sealant or equivalent?
- 7) Have all electrical and water connections been made? Do electrical and water connections meet all national, state, and local code and regulation requirements?
- 8) Has the power supply voltage been checked or tested against the nameplate rating? Has a proper ground been installed to the remote condensing unit and icemaker unit? On three phase model, has the transformer's voltage tap switch been positioned to match incoming voltage? For details, see "I.F. Electrical Connection."
- 9) Has the electrical power supply been on to the remote condensing unit for a minimum of 4 hours?
- 10) Are the water supply and drain lines sized as specified? Are the water supply line shut-off valve and drain valve installed? Has the water supply pressure been checked to ensure a minimum of 10 PSIG and a maximum of 113 PSIG?
Note: The icemaker may stop running when the water supply is off, or if the pressure is below 10 PSIG. When the proper water pressure is reached, the icemaker automatically starts running again.
- 11) Are the compressor hold-down bolts snug? Have the refrigerant lines been checked to make sure they do not rub or touch other lines or surfaces? Have the fan blades been checked to make sure they turn freely?
- 12) Is the line set free of leaks and kinks? If needed, has an "S" oil-trap been installed?
- 13) Are all components, fasteners, and thumbscrews securely in place?
- 14) Has the end user been given the instruction manual, and instructed on how to operate the icemaker and the importance of the recommended periodic maintenance?

- 15) Has the end user been given the name and telephone number of an authorized service agent?
- 16) Has the warranty card been filled out and forwarded to the factory for warranty registration?

I. Startup

⚠ WARNING

All parts are factory-adjusted. Improper adjustments may adversely affect safety, performance, component life, and warranty coverage.

NOTICE

- If the unit is turned off, wait for at least 3 minutes before restarting the unit to prevent damage to the compressor.
- To prevent damage to the water pump seal, do not leave the control switch in the "SERVICE" position when the water tank is empty.
- At startup, confirm that all internal and external connections are free of leaks.
- The remote condensing unit must have power for a minimum of 4 hours prior to startup to prevent compressor damage.

- 1) If removed, replace the splash curtain, front frame, and all panels except the front panel in their correct positions. See Fig. 20. If not already removed, remove the front panel.
- 2) Open the water supply line shut-off valve.
- 3) Move the control switch to the "ICE" position, then replace the front panel in its correct position.
- 4) Turn on the power supply. During the first 5 minutes of the freeze cycle, confirm bin control operation by pressing and holding the bin control's actuator paddle until the icemaker shuts down. The icemaker should shut down in approximately 15 seconds.
- 5) After confirming bin control operation, release the bin control's actuator paddle and allow the icemaker to resume operation.
- 6) After 10 minutes of operation, remove the front panel and move the control switch to the "OFF" position. Turn off the power supply.
- 7) Remove the insulation panel, front frame, and splash curtain.
- 8) Drain the water tank by disconnecting the pump suction hose at the evaporator case wall.
- 9) Disconnect the drain pipe and float connection hose at the evaporator case wall. Disconnect the water tank drain hose from the bottom of the water tank.
- 10) Remove the water tank.
- 11) Clean the dispenser unit/storage bin liner and water tank using a neutral cleaner. Rinse thoroughly after cleaning.
- 12) Replace the water tank in the icemaker, then reconnect the hoses and drain pipe.

- 13) Replace the splash curtain, front frame, and insulation panel in their correct positions and secure with the thumbscrews.
- 14) Seal the outer perimeter of the front frame to the icemaker and dispenser unit/storage bin with RTV-748 sealant (provided) or equivalent. See Fig. 21.
- 15) Move the control switch to the "ICE" position.
- 16) Replace the front panel in its correct position.
- 17) Turn on the power supply to start the automatic icemaking process.

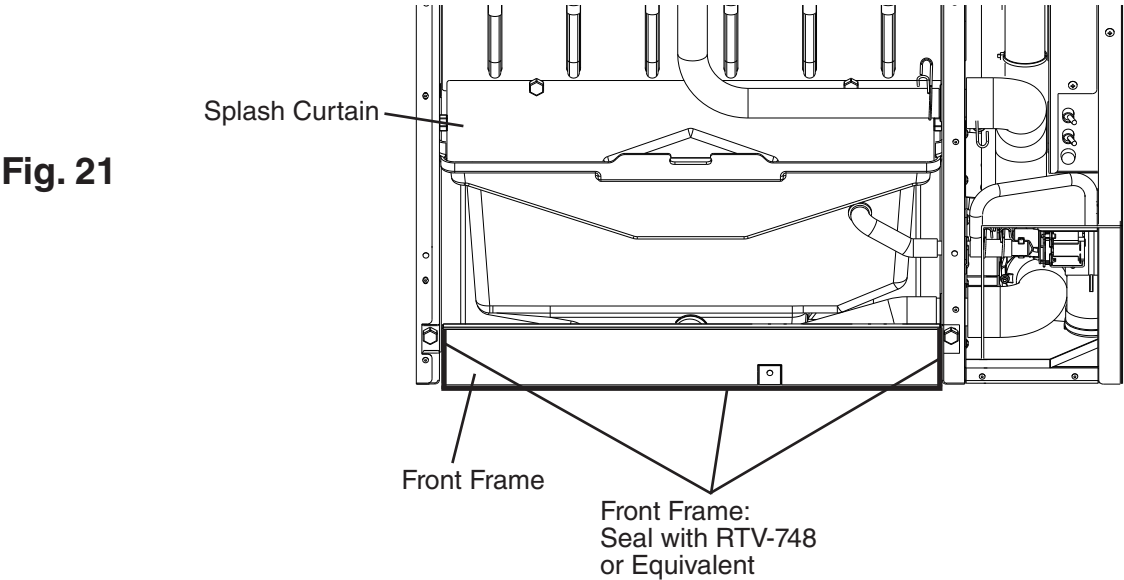
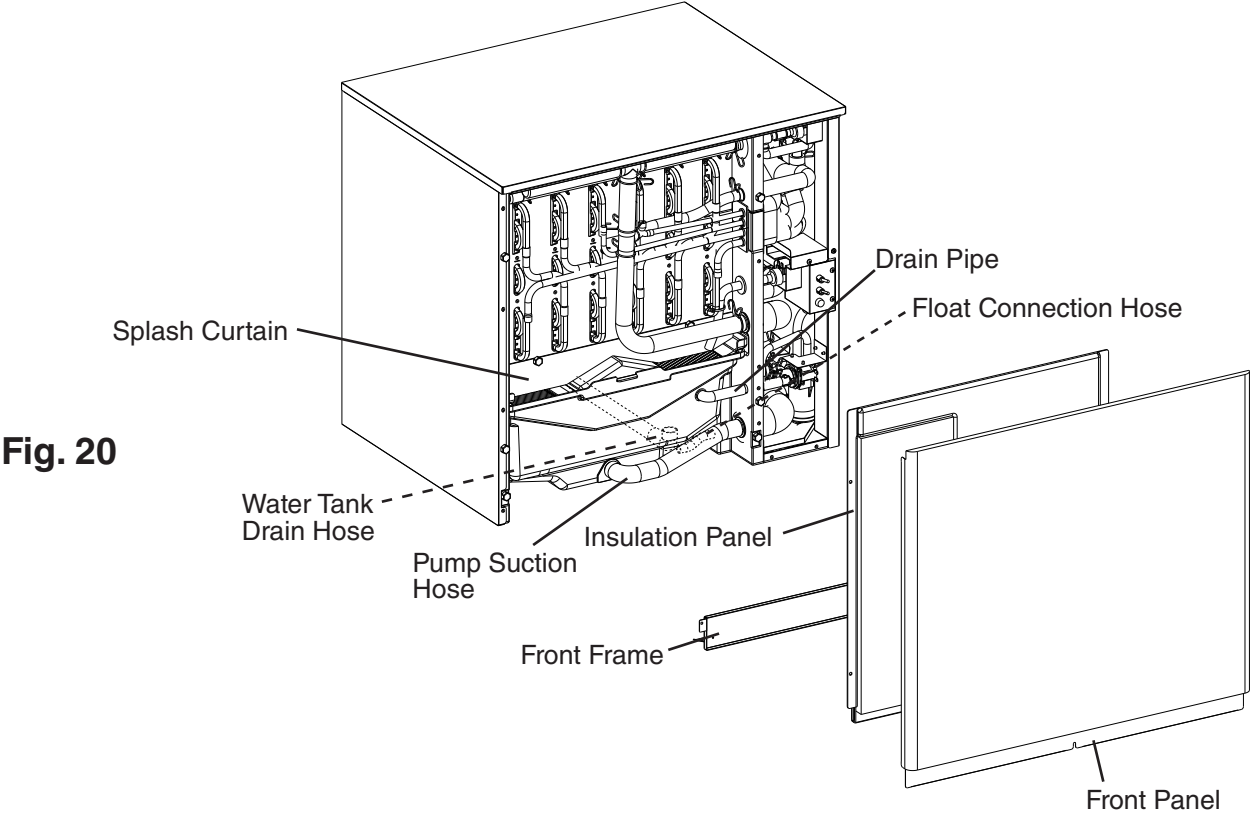

III. Cleaning and Maintenance

This icemaker must be cleaned and maintained in accordance with the instruction manual and labels provided with the icemaker. Consult with your local Hoshizaki Certified Service Representative about cleaning and maintenance service.

⚠ WARNING

- Only qualified service technicians should service this icemaker.
- **CHOKING HAZARD:** Ensure all components, fasteners, and thumbscrews are securely in place after any cleaning or maintenance is done to the unit. Make sure that none have fallen into the dispenser unit/storage bin.

NOTICE

The dispenser unit/storage bin is for ice use only. Do not store anything else in the dispenser unit/storage bin.

A. Cleaning and Sanitizing Instructions

This icemaker must be cleaned and sanitized at least once a year. More frequent cleaning and sanitizing may be required in some water conditions.

⚠ WARNING

- To prevent injury to individuals and damage to the icemaker, do not use ammonia type cleaners.
- Carefully follow any instructions provided with the bottles of cleaning and sanitizing solution.
- Always wear liquid-proof gloves and goggles to prevent the cleaning and sanitizing solutions from coming into contact with skin or eyes.

NOTICE

To prevent damage to the water pump seal, do not operate the icemaker with the control switch in the "SERVICE" position when the water tank is empty.

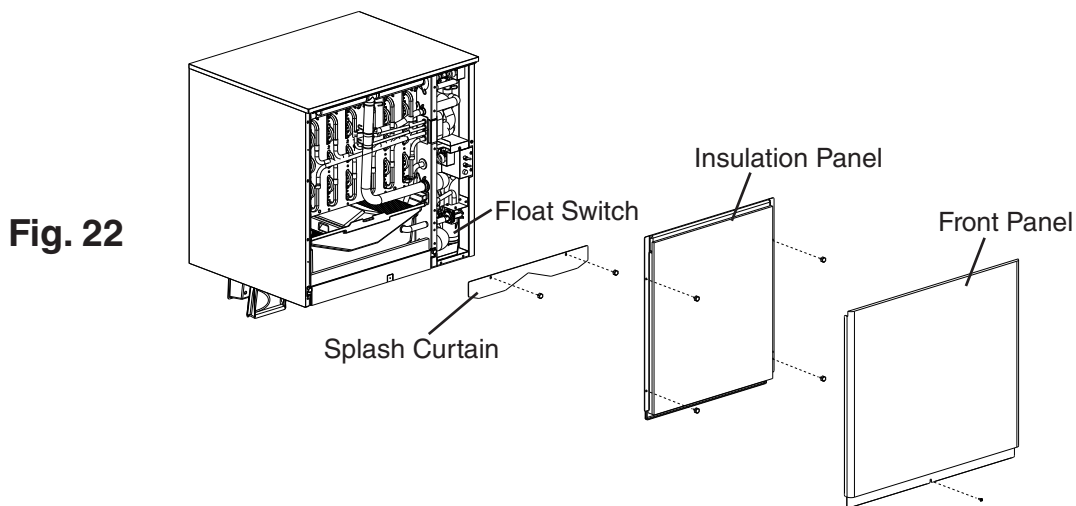

Fig. 22

1. Cleaning Procedure

- 1) Dilute 22 fl. oz. (650 ml) of Hoshizaki "Scale Away" with 4 gal. (15 l) of warm water.
- 2) Remove all ice from the evaporator and the dispenser unit/storage bin.
Note: To remove cubes on the evaporator, turn off the power supply and turn it back on after 3 minutes. The harvest cycle starts and the cubes will be removed from the evaporator.
- 3) Turn off the power supply.
- 4) Remove the front panel, then place the control switch in the "SERVICE" position. Place the service switch in the "DRAIN" position.
- 5) Replace the front panel in its correct position, then turn on the power supply for 2 minutes.
- 6) Turn off the power supply.
- 7) Remove the front panel.
- 8) In bad or severe water conditions, clean the float switch as described below. Otherwise, continue to step 9.
 - a. Remove the right side panel.
 - b. Disconnect the flush tube from the top of the float switch housing, then remove the float switch assembly. Remove the rubber boot from the bottom of the assembly.
 - c. Twist the wire stem on top of the float switch housing to release the float, then lower it out of the housing.
 - d. Wipe down the float switch assembly's housing, shaft, and float with cleaning solution. Clean the inside of the rubber boot and hose with cleaning solution. Rinse the parts thoroughly with clean water.
 - e. Reassemble the float switch assembly and replace it and the rubber boot in their correct positions. Reconnect the flush tube.
 - f. Replace the right side panel in its correct position.
- 9) Remove the insulation panel and splash curtain, then pour the cleaning solution into the water tank.
- 10) Move the service switch to the "WASH" position.
- 11) Replace the splash curtain, insulation panel, and front panel in their correct positions.
- 12) Turn on the power supply to start the washing process.
- 13) Turn off the power supply after 30 minutes. Remove the front panel.
- 14) Move the service switch to the "DRAIN" position.
- 15) Replace the front panel in its correct position, then turn on the power supply for 2 minutes.
- 16) Turn off the power supply, then remove the front panel.
- 17) Move the control switch to the "ICE" position.
- 18) Replace the front panel in its correct position.
- 19) Turn on the power supply to fill the water tank with water.
- 20) Turn off the power supply after 3 minutes.

- 21) Remove the front panel.
- 22) Move the control switch to the "SERVICE" position, then move the service switch to the "WASH" position.
- 23) Replace the front panel in its correct position.
- 24) Turn on the power supply to rinse off the cleaning solution.
- 25) Turn off the power supply after 5 minutes.
- 26) Remove the front panel.
- 27) Move the service switch to the "DRAIN" position.
- 28) Replace the front panel in its correct position, then turn on the power supply for 2 minutes.
- 29) Turn off the power supply. Remove the front panel.
- 30) Repeat steps 17 through 29 three more times to rinse thoroughly.
Note: If you do not sanitize the icemaker, go to step 13 in "2. Sanitizing Procedure."

2. Sanitizing Procedure - Following Cleaning Procedure

- 1) Dilute 2 fl. oz. (60 ml or 4 tbs) of a 5.25% sodium hypochlorite solution (chlorine bleach) with 4 gal. (15 l) of warm water.
- 2) Remove the front panel, insulation panel, and splash curtain if they are in their normal positions.
- 3) Pour the sanitizing solution into the water tank.
- 4) Move the service switch to the "WASH" position.
- 5) Replace the splash curtain, insulation panel, and front panel in their correct positions.
- 6) Turn on the power supply to start the sanitizing process.
- 7) Turn off the power supply after 15 minutes. Remove the front panel.
- 8) Move the service switch to the "DRAIN" position.
- 9) Replace the front panel in its correct position, then turn on the power supply for 2 minutes.
- 10) Turn off the power supply. Remove the front panel.
- 11) Repeat steps 17 through 29 in "1. Cleaning Procedure" two times to rinse thoroughly.
- 12) Repeat steps 1 through 11 one more time.
- 13) Move the control switch to the "ICE" position.
- 14) Replace the front panel in its correct position.
- 15) Clean the dispenser unit/storage bin liner using a neutral cleaner. Rinse thoroughly after cleaning.
- 16) Turn on the power supply to start the automatic icemaking process.

B. Maintenance

This icemaker must be maintained individually, referring to the instruction manual and labels provided with the icemaker.

WARNING

- Only qualified service technicians should service this icemaker.
- Move the control switch to the "OFF" position and turn off the power supply to the remote condensing unit before servicing. Place the icemaker disconnect (if applicable) in the off position. Lockout/Tagout to prevent the power supply from being turned back on inadvertently.

1. Stainless Steel Exterior

To prevent corrosion, wipe the exterior occasionally with a clean, soft cloth. Use a damp cloth containing a neutral cleaner to wipe off oil or dirt buildup.

2. Storage Bin Scoop

- Wash your hands before removing ice from the storage bin. Use the plastic scoop provided (storage bin accessory).
- Clean the scoop using a neutral cleaner. Rinse thoroughly after cleaning.

3. Dispenser Unit/Storage Bin

- The dispenser unit/storage bin is for ice use only. Do not store anything else in the dispenser unit/storage bin.
- Clean the dispenser unit/storage bin liner using a neutral cleaner. Rinse thoroughly after cleaning.

4. Condenser

Check the condenser once a year, and clean the coil if required by using a brush or vacuum cleaner. More frequent cleaning may be required depending on location.

C. Preparing the Icemaker for Periods of Non-Use

NOTICE

- When storing the icemaker for an extended time or in sub-freezing temperatures, follow the instructions below to prevent damage.
- To prevent damage to the water pump, do not operate the icemaker with the control switch in the "SERVICE" position when the water tank is empty.

When the icemaker is not used for two or three days under normal conditions, it is sufficient to move the control switch to the "OFF" position. When storing the icemaker for an extended time or in sub-freezing temperatures, follow the instructions below.

- 1) Turn off the power supply, then remove the front panel.
- 2) Move the control switch on the control box to the "OFF" position. Confirm that the service switch is in the "CIRC." position.
- 3) Remove the front insulation, front frame, right side panel, and control box cover.
- 4) Disconnect the white thermistor connector from the control board WHITE K3 connector, then unplug the water pump connector at the water pump.
- 5) Wait 3 minutes, then move the control switch to the "ICE" position. Confirm that the bin control switch is closed and calling for ice. The green "BC CLOSED" LED on the control board should be on.
- 6) Once LED 1 and 2 on the control board energize (the order of the LEDs from the outer edge of the control board is 1, 4, 3, 2), close the inlet water supply line shut-off valve and open the inlet water supply line drain valve. Allow the line to drain by gravity.
- 7) Disconnect the harvest water valve hose in the evaporator section and blow out the water line to the harvest water valve using compressed air or carbon dioxide. See Fig. 23. This will clear water from the harvest water valve.
- 8) Move the control switch to the "OFF" position.
- 9) Move the service switch to the "WASH" position and the control switch to the "SERVICE" position.
- 10) Using the same hose as with the harvest water valve, blow out the wash valve using compressed air or carbon dioxide.
- 11) Move the service switch to the "CIRC." position and the control switch to the "OFF" position.
- 12) Remove the 4 hoses connected to the water tank. Allow the tank and hoses to completely drain.
- 13) Move the control switch to the "ICE" position.
- 14) Using the fill water valve hose, blow out the water line using compressed air or carbon dioxide. This will clear water from the fill water valve.
- 15) Move the control switch to the "OFF" position.
- 16) Disconnect the float switch vent hose from the drain hose tee. Move the service switch to the "DRAIN" position and the control switch to the "SERVICE" position.

- 17) From the tee on the drain hose, blow out the drain valve using compressed air or carbon dioxide.
- 18) Move the service switch to the "CIRC." position and the control switch to the "OFF" position.
- 19) Reconnect the thermistor to the K3 connector on the control board. Reconnect the water pump connector.
- 20) Close the inlet water supply line drain valve.
- 21) Remove all ice from the dispenser unit/storage bin and clean the dispenser unit/storage bin liner using a neutral cleaner. Rinse thoroughly after cleaning.
- 22) Turn off the power supply.
- 23) Replace all removed parts and panels in their correct positions.

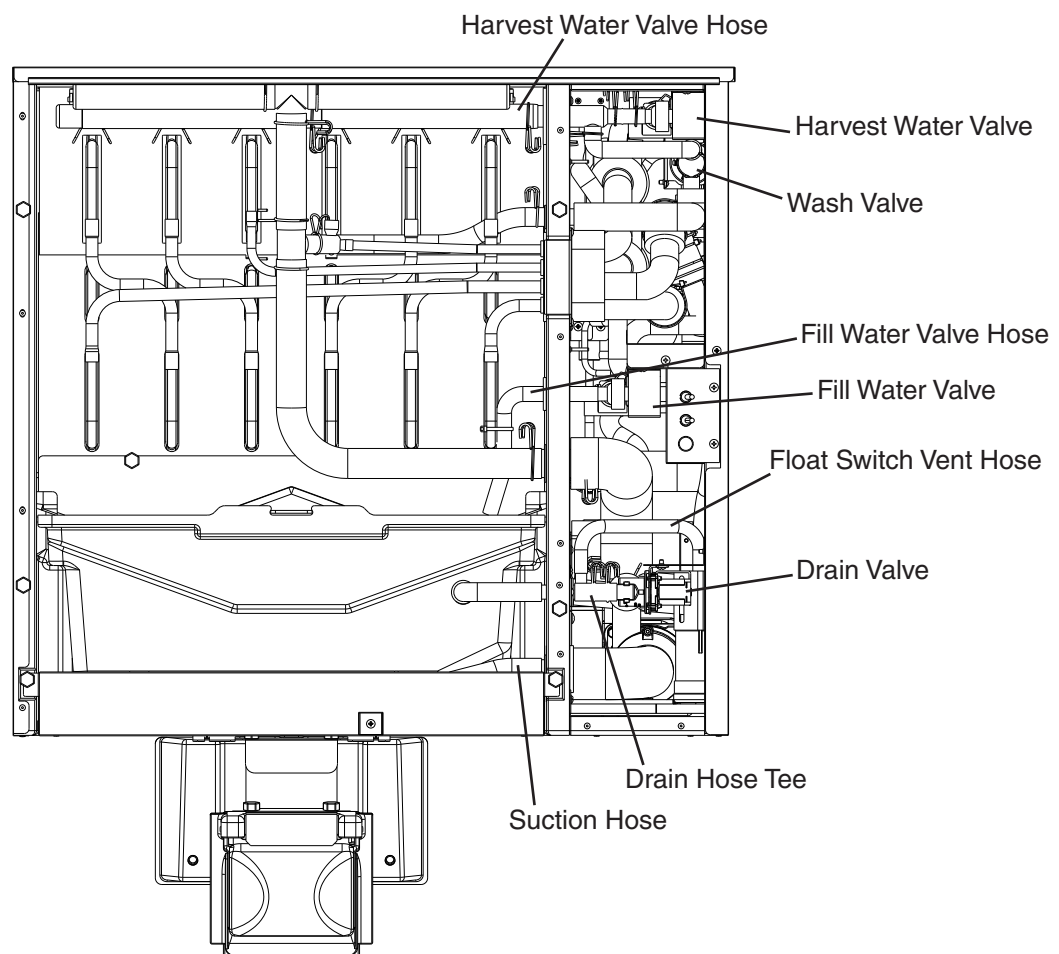

Fig. 23

HOSHIZAKI AMERICA, INC.

618 Hwy. 74 S., Peachtree City, GA 30269 USA | TEL (770) 487-2331 | FAX (770) 487-3360 | www.hoshizaki.com | 1A3073-010