

Hoshizaki America, Inc.

Modular Crescent Cuber Serenity Series

Model
KMS-1122MLH with SRK-12H/3



“A Superior Degree
of Reliability”

www.hoshizaki.com

SERVICE MANUAL



Number: 73194
Issued: 4-4-2013

⚠ WARNING

Only qualified service technicians should install and service the appliance. To obtain the name and phone number of your local Hoshizaki Certified Service Representative, visit www.hoshizaki.com. No service should be undertaken until the technician has thoroughly read this Service Manual. Failure to service and maintain the appliance in accordance with this manual will adversely affect safety, performance, component life, and warranty coverage and may result in costly water damage. Proper installation is the responsibility of the installer. Product failure or property damage due to improper installation is not covered under warranty.

Hoshizaki provides this manual primarily to assist qualified service technicians in the service of the appliance.

Should the reader have any questions or concerns which have not been satisfactorily addressed, please call, send an e-mail message, or write to the Hoshizaki Technical Support Department for assistance.

Phone: 1-800-233-1940; (770) 487-2331

Fax: 1-800-843-1056; (770) 487-3360

E-mail: techsupport@hoshizaki.com

HOSHIZAKI AMERICA, INC.

618 Highway 74 South

Peachtree City, GA 30269

Attn: Hoshizaki Technical Support Department

Web Site: www.hoshizaki.com

NOTE: To expedite assistance, all correspondence/communication **MUST** include the following information:

- Model Number _____
- Serial Number _____
- Complete and detailed explanation of the problem.

IMPORTANT

This manual should be read carefully before the appliance is serviced. Read the warnings and guidelines contained in this manual carefully as they provide essential information for the continued safe use, service, and maintenance of the appliance. Retain this manual for any further reference that may be necessary.

CONTENTS

Important Safety Information	5
I. Construction and Water/Refrigeration Circuit Diagrams	7
A. Construction	7
1. Icemaker	7
2. Condensing Unit	8
B. Water/Refrigeration Circuit Diagram	9
II. Sequence of Operation and Service Diagnosis	10
A. Sequence of Operation Flow Chart	10
B. Service Diagnosis	11
C. Control Board Check	16
D. Bin Control Check	17
E. Float Switch Check and Cleaning	17
F. Thermistor Check	20
G. Diagnostic Tables	21
III. Controls and Adjustments	25
A. Control Board Layout	26
B. LED Lights and Audible Alarm Safeties	27
C. Settings and Adjustments	28
1. Default Dip Switch Settings	28
2. Harvest Timer (S4 dip switch 1 & 2)	29
3. Pump-Out Timer (S4 dip switch 3 & 4)	29
4. Pump-Out Frequency Control (S4 dip switch 5 & 6)	30
5. Harvest Pump Timer (S4 dip switch 7)	30
6. Factory Use (S4 dip switch 8)	30
7. Freeze Timer (S4 dip switch 9 & 10)	31
8. Float Switch Selector (S5 dip switch 1)	31
9. Refill Counter (S5 dip switch 2 through 5)	32
D. Control Switch and Service Switch	33
IV. Refrigeration Circuit and Component Service Information	34
A. Refrigeration Circuit Service Information	34
B. Component Service Information	37
V. Maintenance	38
VI. Preparing the Appliance for Periods of Non-Use	39
VII. Disposal	40

- VIII. Technical Information..... 41
 - A. Specification Sheets..... 41
 - 1. KMS-1122MLH with SRK-12H..... 41
 - 2. KMS-1122MLH with SRK-12H3 42
 - 3. SRK-12H..... 43
 - 4. SRK-12H3..... 44
 - B. Performance Data 45
 - 1. KMS-1122MLH with SRK-12H..... 45
 - 2. KMS-1122MLH with SRK-12H3 46
 - C. Wiring Diagrams..... 47
 - 1. Wire Harness Connections..... 47
 - 2. KMS-1122MLH with SRK-12H 48
 - 3. KMS-1122MLH with SRK-12H3 49

Important Safety Information

Throughout this manual, notices appear to bring your attention to situations which could result in death, serious injury, damage to the appliance, or damage to property.

⚠ WARNING Indicates a hazardous situation which could result in death or serious injury.

NOTICE Indicates a situation which could result in damage to the appliance or property.

IMPORTANT Indicates important information about the use and care of the appliance.

⚠ WARNING

The appliance should be destined only to the use for which it has been expressly conceived. Any other use should be considered improper and therefore dangerous. The manufacturer cannot be held responsible for injury or damage resulting from improper, incorrect, and unreasonable use. Failure to service and maintain the appliance in accordance with this manual will adversely affect safety, performance, component life, and warranty coverage and may result in costly water damage.

To reduce the risk of death, electric shock, serious injury, or fire, follow basic precautions including the following:

- Only qualified service technicians should install and service the appliance.
- The appliance must be installed in accordance with applicable national, state, and local codes and regulations. Failure to meet these code requirements could result in death, electric shock, serious injury, fire, or damage to the appliance.
- To reduce the risk of electric shock, do not touch the control switch or service switch with damp hands.
- Before servicing the KMS or SRK: Move the KMS control switch to the "OFF" position and turn off the power supply to the SRK condensing unit. Place the KMS disconnect (if applicable) in the "OFF" position. Lockout/Tagout to prevent the power supply from being turned back on inadvertently.
- Do not make any alterations to the appliance. Alterations could result in electric shock, injury, fire, or damage to the appliance.
- The appliance is not intended for use by persons (including children) with reduced physical, sensory, or mental capabilities, or lack of experience and knowledge, unless they have been given supervision or instruction concerning use of the appliance by a person responsible for their safety.
- Children should be properly supervised around the appliance.
- Do not climb, stand, or hang on the appliance or allow children or animals to do so. Serious injury could occur or the appliance could be damaged.
- Do not use combustible spray or place volatile or flammable substances near the appliance. They might catch fire.
- Keep the area around the appliance clean. Dirt, dust, or insects in the appliance could cause harm to individuals or damage to the appliance.

⚠ WARNING, continued

For KMS

- Risk of electric shock. Control switch in "OFF" position does not de-energize all loads.
- Power supply and ground connection are supplied from the SRK remote condensing unit via the wire harness provided. Do not connect the wire harness leads to an external power source.
- Wire harness routing (conduit) and disconnect (if required) must meet national, state, and local electrical code requirements. Failure to meet these code requirements could result in death, electric shock, serious injury, fire, or damage to the appliance.
- **THE ICEMAKER MUST BE GROUNDED.** Failure to properly ground the icemaker could result in death, serious injury, or damage to the appliance.

For SRK

- Electrical connection must be hard-wired and must meet national, state, and local electrical code requirements. Failure to meet these code requirements could result in death, electric shock, serious injury, fire, or damage to the appliance.
- The remote condensing unit requires an independent power supply of proper capacity. See the nameplate for electrical specifications. Failure to use an independent power supply of proper capacity can result in a tripped breaker, blown fuses, damage to existing wiring, or component failure. This could lead to heat generation or fire.
- **THE REMOTE CONDENSING UNIT MUST BE GROUNDED.** Failure to properly ground the remote condensing unit could result in death, serious injury, or damage to the appliance.

NOTICE

- Follow the instructions in this manual carefully to reduce the risk of costly water damage.
- In areas where water damage is a concern, install in a contained area with a floor drain.
- Install the appliance in a location that stays above freezing. Normal operating ambient temperature must be within 45°F to 100°F (7°C to 38°C).
- Do not leave the appliance on during extended periods of non-use, extended absences, or in sub-freezing temperatures. To properly prepare the appliance for these occasions, follow the instructions in "VI. Preparing the Appliance for Periods of Non-Use."
- Do not place objects on top of the appliance.
- The dispenser unit/ice storage bin is for ice use only. Do not store anything else in the dispenser unit/ice storage bin.

I. Construction and Water/Refrigeration Circuit Diagrams

A. Construction

1. Icemaker

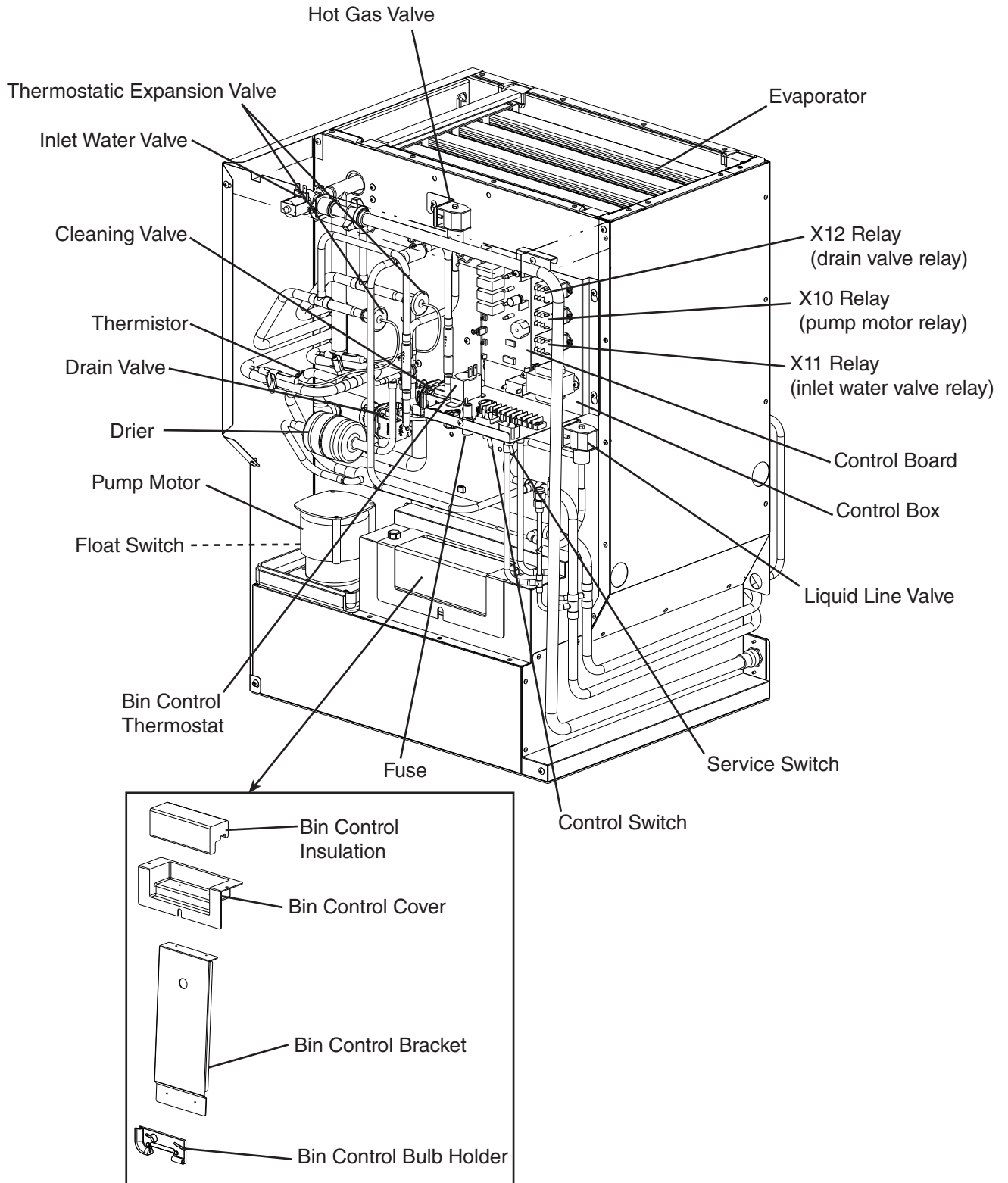

2. Condensing Unit

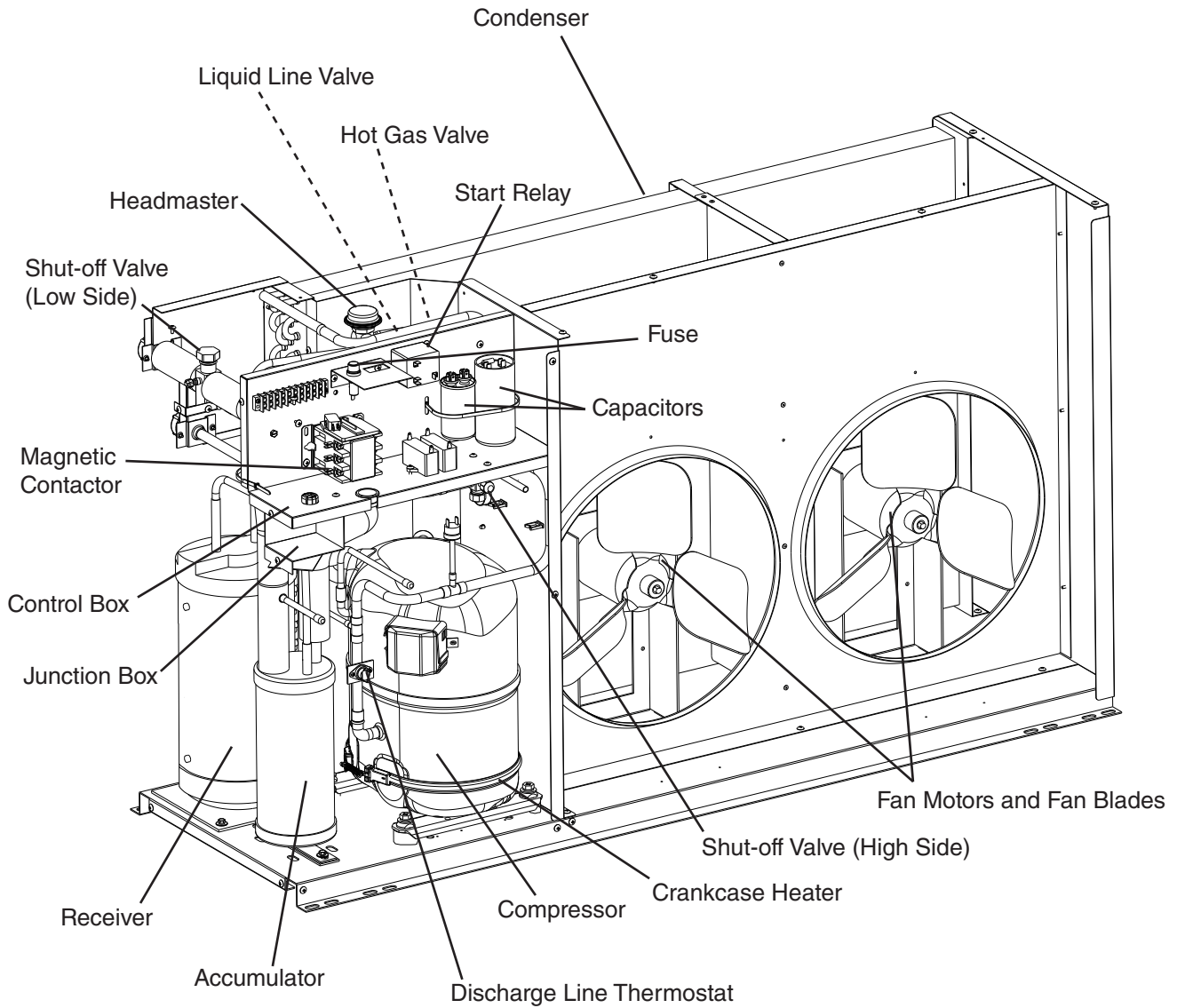

Model Shown: SRK-12H

B. Water/Refrigeration Circuit Diagram

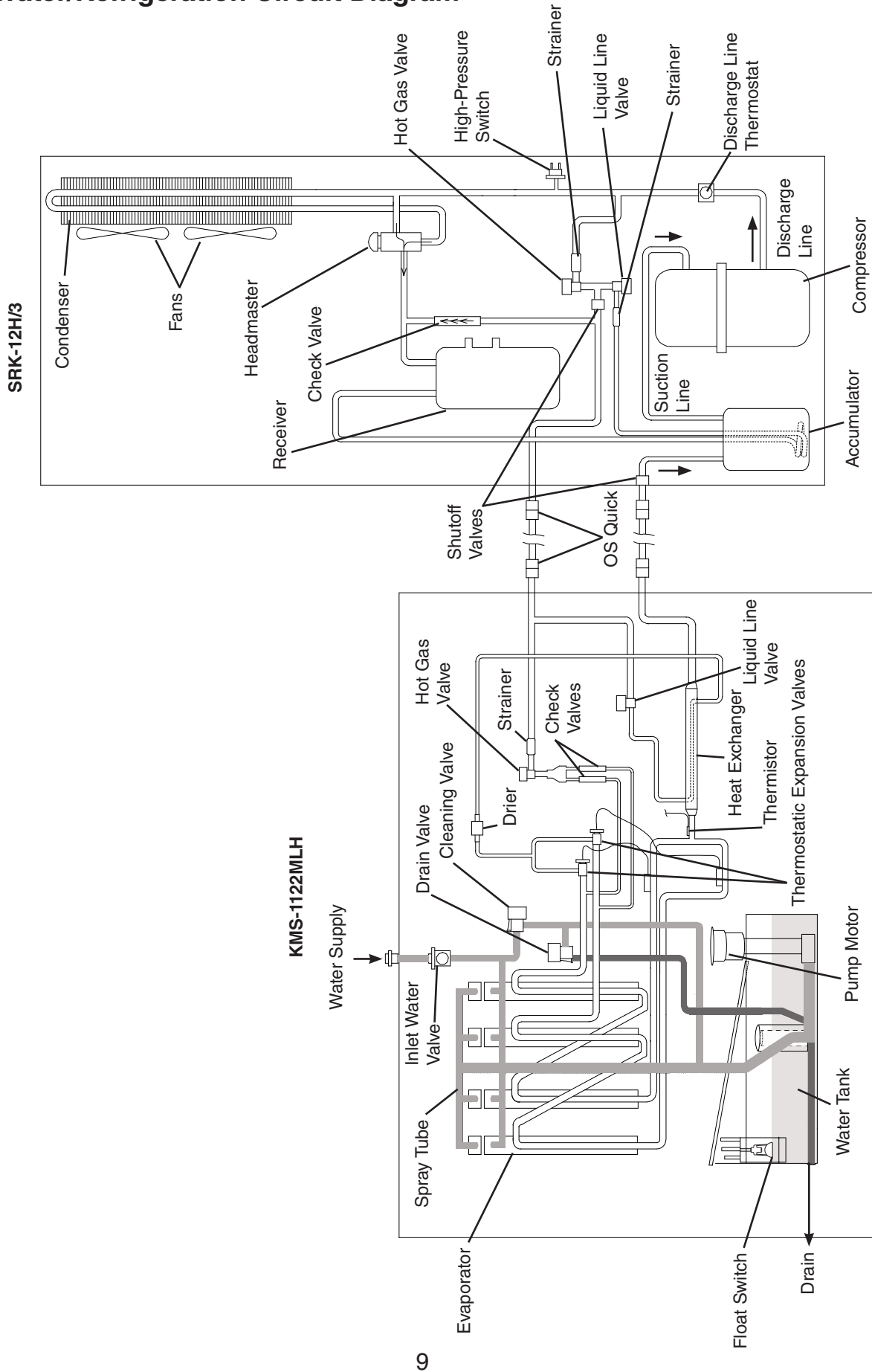

II. Sequence of Operation and Service Diagnosis

A. Sequence of Operation Flow Chart

**"G" Control Board Sequence Flow Chart
KMS-1122MLH with SRK-12H/3**

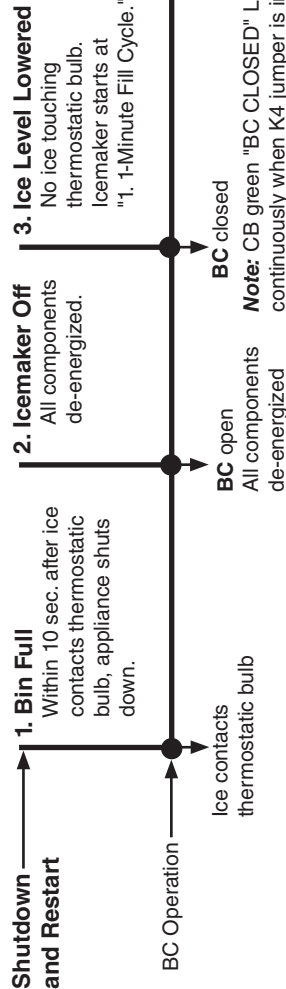
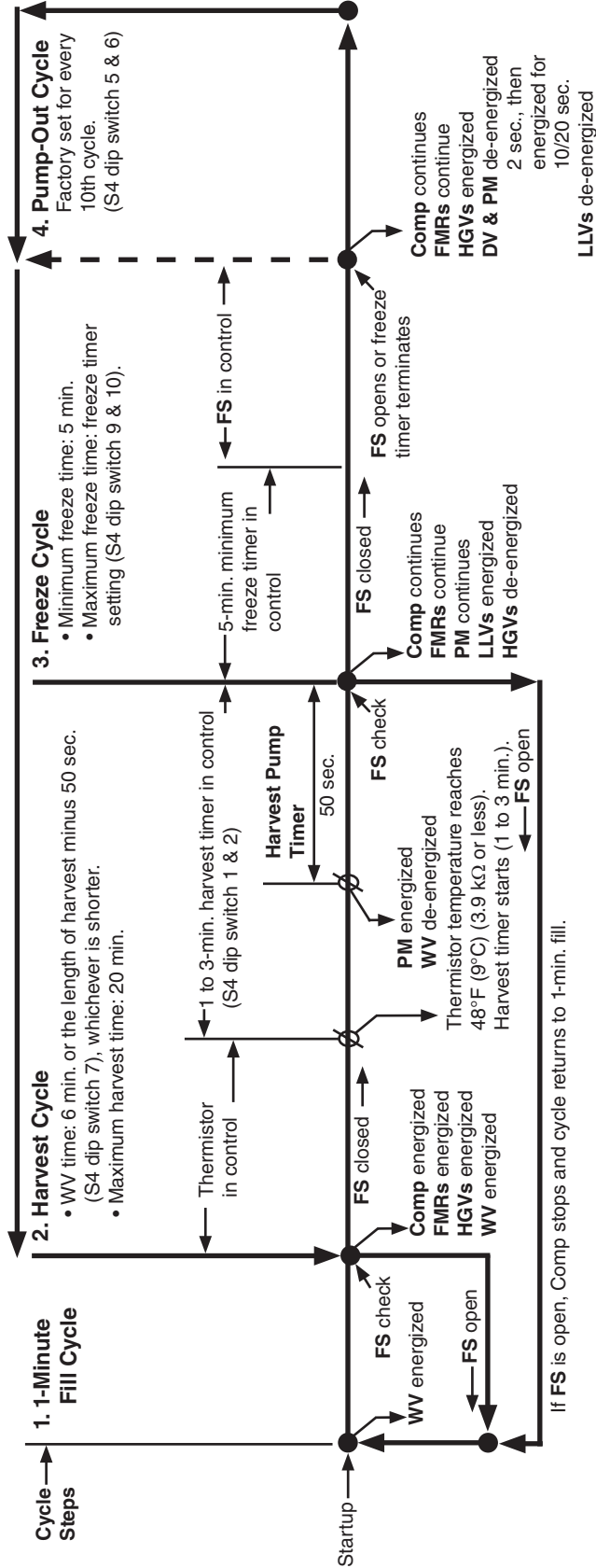

Legend:

- BC-bin control
- Comp-compressor
- DV-drain valve
- FMRs-fan motors-remote
- FS-float switch
- HGVs-hot gas valves (KMS and SRK)
- LLVs-liquid line valves (KMS and SRK)
- PM-pump motor
- WV-inlet water valve

Components Energized when the Control Switch is in the "SERVICE" Position

When in the "SERVICE" position, the control switch supplies power to the service switch and the icemaker is in service mode. The service switch has three positions: "DRAIN," "CIRCULATE," and "WASH." See the information below for details of each function.

DRAIN	Power is supplied to the pump and drain valve. This drains the water tank.
CIRCULATE	Power is supplied to the pump only. This operation can be used to circulate cleaner and sanitizer over the outside surface of the evaporator for extended periods of time.
WASH	Power is supplied to the pump and cleaning valve. This operation is used to circulate cleaner and sanitizer over both the inside and outside surfaces of the evaporator.

B. Service Diagnosis

WARNING

- The appliance should be diagnosed and repaired only by qualified service personnel to reduce the risk of death, electric shock, serious injury, or fire.
- Risk of electric shock. Use extreme caution and exercise safe electrical practices.
- Risk of electric shock. Control switch (KMS) in "OFF" position does not de-energize all loads.
- Moving parts (e.g., fan blade) can crush and cut. Keep hands clear.
- **CHOKING HAZARD:** Ensure all components, fasteners, and thumbscrews are securely in place after the appliance is serviced. Make sure that none have fallen into the dispenser unit/ice storage bin.
- Make sure all food zones in the icemaker and dispenser unit/ice storage bin are clean after service.

1. Diagnostic Procedure

The diagnostic procedure is a sequence check that allows you to diagnose the electrical system and components. Before proceeding, check for correct installation, proper voltage per nameplate, and adequate water supply.

Note: • When checking high voltage (115VAC), always choose a neutral (W) to establish a good neutral connection.

- On 3-phase models, the neutral (W) is provided through MT. To confirm a good neutral (W), check for 60VAC from neutral (W) to ground (GND). If 60VAC is present, neutral (W) is good. If 60VAC is not present, check 208-230VAC main power supply to MT. If 208-230VAC is present, check MT continuity.
- When checking voltage from the CB K1 connector (10 pin connector), pull CB K1 connector out slightly to allow room for multimeter test leads contact.

- 1) Turn off the power supply, then access the control box. Clear any ice from BC.
- 2) Check that the 115VAC 10A fuses in the KMS and SRK are good.

3) **Power On:** Turn on the power supply, then move the control switch (KMS) to the "ICE" position. A 5-sec. delay occurs. CB red "POWER OK" LED and green "BC CLOSED" LED turn on.

Note: • CB red "POWER" LED remains on unless the 10.5VAC power supply is interrupted (K2 connector). CB green "BC CLOSED" LED remains on unless CB black K4 jumper is loose or removed.

- Check CB using the steps in "II.C. Control Board Check."

Power On Diagnosis: If CB red "POWER OK" LED is off, confirm BC is closed, then check for 10.5VAC at CB K2 connector red wire to red wire. If 10.5VAC is not present, check for 115VAC at CT, then at control switch. If 115VAC is not present at the control switch, check that the wire harness is securely connected to KMS and SRK. Check for 115VAC at terminal block #1 (BR) to a neutral (W). If 115VAC is present check BC continuity. If 115VAC is not present, check that the SRK HPS and DLT are closed. If open, see HPS or DLT diagnosis below. If CB red "POWER OK" LED is on, confirm CB green "BC CLOSED" LED is on. If not, confirm that the jumper required on CB red K4 connector is in place and securely attached. If CB yellow "BC OPEN" LED is on with required jumper in place, replace CB.

HPS Diagnosis: Check that the condenser coil is not clogged or restricted. Check that there are no restrictions in the refrigeration circuit (TXV and drier). Let refrigeration circuit pressures equalize. If HPS does not reset and pressures are equalized, replace HPS. If pressures are not equalized, reclaim refrigerant and diagnose refrigeration circuit restriction.

DLT Diagnosis: Allow time for DLT to cool and reset. If DLT does not reset, replace DLT.

Confirm that the location meets factory requirements:

- The appliance is not intended for outdoor use. Normal operating ambient temperature should be within 45°F to 100°F (7°C to 38°C).
- The appliance should not be located in a corrosive environment.

4) **1-Minute Fill Cycle – LED 4 is on.** WV and X11 relay energize. After 1 min., CB checks for a closed FS. If FS is closed, the harvest cycle begins. If harvest cycle begins (Comp energized), continue to step 4. If FS is open, WV remains energized through additional 1-min. fill cycles until water enters the water tank and FS closes (low water safety protection during initial start up and at the end of each harvest). **Diagnosis:** Check that water enters the water tank. If not, check that the water supply line shut-off valve is open and screens or external filters are clear. Confirm that FS is open, see "II.E. Float Switch Check and Cleaning." If FS is open, LED 4 is off, and "POWER OK" LED is on, check for 115VAC at CB K1 connector pin #6 (O) to a neutral (W). If 115VAC is not present, replace CB. If LED 4 is on and 115VAC is present, check for 115VAC at WV solenoid. If 115VAC is present, check WV solenoid continuity. If the water tank fills, but the icemaker fails to start harvest (Comp energized), check for open FS. See "II.E. Float Switch Check and Cleaning." If FS is closed and CB fails to start the harvest cycle after 1 min., replace CB.

5) **Initial Harvest Cycle – LEDs 1, 4, and 2 are on.** WV and X11 relay continue. Comp, FMRs, HGVs, and X10 relay energize. CB monitors the warming of the evaporator via the thermistor located on the suction line. When the thermistor reaches 48°F (9°C), CB reads 3.9 kΩ from the thermistor and turns harvest termination over to the harvest timer (S4 dip switch 1 & 2). The harvest timer has settings of 60, 90, 120, and 180 sec. The pump-out timer (S4 dip switch 3 & 4) acts in place of the harvest timer during cycles with a pump-out (S4 dip switch 5 & 6). WV and X11 relay are energized during harvest for a maximum of 6 min. or the length of harvest minus 50 sec., whichever is shorter. 50 sec. before the harvest timer terminates, harvest pump timer starts. LED 4 turns off, WV and X11 relay de-energize.

Harvest Pump Timer – LEDs 1, 3, and 2 are on. Comp, FMRs, HGVs, and X10 relay continue. LED 3 turns on and PM energizes for the last 50 sec. of harvest (S4 dip switch 7). WV and X11 relay de-energize.

NOTICE! S4 dip switch 7 must remain in the factory default position of 7 on.

Otherwise, PM will not energize during the last 50 sec. of harvest. The minimum total time allowed by CB for a complete harvest cycle is 2 min.. At the end of harvest, CB checks the position of FS and proceeds to the next cycle if it is closed, or calls for a 1-min. fill cycle if it is open.

- a) **Comp, FMRs, HGVs, and LLVs Diagnosis:** Check that evaporator is warming. If not, confirm that Comp is energized. If not, check for 115VAC at CB K1 connector pin #1 or #9 (V) to a neutral (W). If 115VAC is not present, check wire harness connection. If wire harness is loose, reconnect. If 115VAC is present, check for 115VAC at MC coil. If 115VAC is present, confirm MC contacts are closed. If not, replace MC. If MC contacts are closed, check Comp motor windings. If FMRs are not energized and MC is energized, check FMRs motor windings and fan blades turns freely. If Comp is energized and evaporator is not warming, check that HGVs are open. Check for 115VAC at CB K1 connector pin #2 (P) to a neutral (W). If 115VAC is present, check coil voltage and continuity of both KMS and SRK HGVs. Replace as needed. Confirm that both LLVs (KMS and SRK) are de-energized and closed. If evaporator is warming, place a thermometer on the suction line next to the thermistor. Has it warmed to 48°F (9°C) or warmer? Confirm thermistor status. See "II.F. Thermistor Check." If thermistor is in range, harvest pump timer should start.
- b) **PM Diagnosis:** Confirm WV de-energizes, LED 4 turns off, PM energizes, and LED 3 turns on 50 sec. before harvest cycle terminates. If not, confirm S4 dip switch 7 is in the on position. Check for 115VAC at CB K1 connector pin #6 (O). If 115VAC is present, and LED 4 is off, replace CB. Check that LED 3 turns on and PM is energized for the last 50 sec. of harvest cycle. If LED 3 is on and PM is not energized, check for 115VAC at CB K1 connector pin #5 (DBU). If 115VAC is present and PM is not energized, check for 115VAC at X10 relay coil. If 115VAC is present, check for 115VAC at X10 relay terminal #4 (R) to a neutral (W). If 115VAC is not present, check X10 relay coil continuity and contact continuity. If 115VAC is present, check control switch contact continuity between terminals #6 (R) and #5 (R). If contacts are open, replace control switch. If contacts are closed and 115VAC is present between control switch terminal #5 (R) and neutral (W), check PM capacitor and motor winding continuity. If the thermistor reading is in proper range and CB fails to terminate the harvest cycle, replace CB. If 1-min. fill cycle starts after harvest, see "II.E. Float Switch Check and Cleaning."

6) **Freeze Cycle – LED 1 is on.** Comp, FMRs, and PM continue. LLVs energize. HGVs and X10 relay de-energize. The appliance is held in freeze by a 5-min. short cycle protection timer. When FS opens, the freeze cycle terminates.

Note: CB K1 connector pin #5 (DBU) de-energizes and K1 connector pin #4 (R) energizes to prevent PM interruption.

Freeze Cycle Diagnosis: During the first 5 min. of freeze, confirm evaporator is cooling. If not, confirm LLVs energize and HGVs de-energize (not bypassing). If LLVs do not energize, check for 115VAC at CB K1 connector pin #3 (BK) to a neutral (W). If 115VAC is present, check coil voltage and continuity of both LLVs (KMS and SRK). Confirm that both HGVs (KMS and SRK) are de-energized and closed. If evaporator is still not cooling, check TXVs and HM for proper operation. Check for proper appliance pressures or an inefficient Comp. See "VIII.B. Performance Data." If PM de-energizes once freeze begins, check for 115VAC at CB K1 connector pin #4 (R) to a neutral (W). If 115VAC is not present, replace CB.

Freeze Termination Diagnosis: Disconnect CB black K5 connector. When 5 or more min. have elapsed in the freeze cycle, the appliance should switch out of freeze. After the appliance switches out of freeze, reconnect CB black K5 connector. If the appliance remains in freeze with FS disconnected, replace CB. To check FS, see "II.E. Float Switch Check and Cleaning." If water tank is empty before 5 min. timer terminates and freeze cycle is short, check that DV is not leaking by or energized (water flowing down the potable drain). If DV is energized, check X12 relay terminal #4 (GY) for 115VAC. If 115VAC is present, and LED 1 is on, replace CB.

Note: Normal freeze cycle will last 30 to 35 min. depending on model and conditions. Cycle times and pressures should follow performance data provided in this manual. See "VIII.B. Performance Data."

7) **Pump-Out Cycle – LEDs 1, 3, and 2 are on (10/20 second pump-out) –**

At the factory setting the 1st pump-out occurs after the 11th freeze cycle, then every 10th cycle thereafter. See the table below.

S4 Dip Switch Setting		Pump-Out Frequency	1st Pump-Out
No. 5	No. 6		
OFF	OFF	Every cycle	After 2nd freeze cycle
ON	OFF	Every 2 cycles	After 3rd freeze cycle
OFF	ON	Every 5 cycles	After 6th freeze cycle
ON	ON	Every 10 cycles	After 11th freeze cycle

Comp and FMRs remain energized. HGVs energize. LLVs de-energize. PM de-energizes for 2 sec., then PM and DV energize for 10 sec.

The pump-out removes contaminants from the water tank through DV.

PM Diagnosis: In the freeze cycle before pump-out (see table above), disconnect CB black K5 connector (FS connector) after 5 min. of freeze. If PM does not energize after 2 sec., check that CB LEDs 1, 3, and 2 are on. If not, replace CB. If LED 1, 3, and 2 are on and PM does not energize, check for 115VAC at CB K1 connector pin #5 (DBU) to a neutral (W). If LED 3 is on and 115VAC is not present, replace CB. If 115VAC is present, check for 115VAC at X10 relay terminal #2 (DBU) to a neutral (W). If 115VAC is not present, replace X10 relay. If 115VAC is present, check for 115VAC at X12 relay, terminal #7 (DBU) to a neutral (W). If 115VAC is present, and PM is not energized, check X12 relay coil continuity. If open, replace X12 relay. If 115VAC is present, check for 115VAC at X12 relay terminal #3 (R) to a neutral (W). If 115VAC is not present, confirm 115VAC at X12 relay terminal #5 (BR) to a neutral. If 115VAC is present on terminal #5 (BR) but not on terminal #3 (R), replace X12 relay. If 115VAC is not present on terminal #5 (BR), check all (BR) connections. Next, check PM capacitor and PM windings. **DV Diagnosis:** If water does not pump out, check for 115VAC at X12 relay terminal #4 (GY) to a neutral (W). If 115VAC is not present, confirm 115VAC at X12 relay terminal #6 (DBU). If 115VAC is present on X12 relay terminal #6 (DBU) and not on X12 relay terminal #4 (GY), replace X12 relay. If 115VAC is present on X12 relay terminal #4 (GY), check DV coil continuity. If open, replace DV. Next, remove DV housing and check/clean DV assembly. Make sure the drain line is not clogged.

8) **Normal Harvest Cycle** – Same as the initial harvest cycle. Return to step 5.

Note: Icemaker continues to cycle until BC is satisfied or power is switched off. The appliance always restarts at the 1-min. fill cycle.

9) **Shutdown**—When the appliance is running hold ice in contact with the thermostatic bulb. BC switch opens within 10 sec., shutting down the appliance. BC is factory set, and generally no adjustment is required. However, adjustment may be needed in some conditions, particularly at higher altitude locations. **Diagnosis:** See "II.D. Bin Control Check."

Legend: **BC**—bin control; **CB**—control board; **Comp**—compressor; **CT**—control transformer; **DLT**—discharge line thermostat; **DV**—drain valve; **FMRs**—fan motors-remote; **FS**—float switch; **HGVs**—hot gas valves; **HM**—headmaster; **HPS**—high-pressure switch; **LLVs**—liquid line valves; **MC**—magnetic contactor; **MT**—main transformer; **PM**—pump motor; **TXVs**—thermostatic expansion valves; **WV**—inlet water valve; **X10**—pump motor relay; **X11**—inlet water valve relay; **X12**—drain valve relay

C. Control Board Check

Before replacing a CB that does not show a visible defect and that you suspect is bad, always conduct the following check procedure. This procedure will help you verify your diagnosis.

Alarm Reset: If CB is in alarm (beeping), press the "ALARM RESET" button on CB while CB is beeping. **WARNING! Risk of electric shock. Care should be taken not to touch live terminals.** Once reset, the appliance starts at the 1-min. fill cycle. For audible alarm information, see "III.B. LED Lights and Audible Alarm Safeties."

- 1) Check the dip switch settings to assure that S4 dip switch 3, 4, 7, 8, 9, 10, and S5 dip switch 1 through 5 are in the factory default position. S4 dip switch 1, 2, 5, 6 are cleaning adjustments and the settings are flexible. For factory default settings, see "III.C.1. Default Dip Switch Settings."
- 2) Move the control switch to the "ICE" position. If the red "POWER OK" LED is on, CB control voltage is good, continue to step 3. If the red "POWER OK" LED is off, check CT secondary circuit. CT output is 10.5VAC at 115VAC primary input. If the secondary circuit has proper voltage and the red LED is off, replace CB.

If the secondary circuit does not have proper voltage, check CT primary circuit. Check for 115VAC at CB K1 connector pin #10 (BR) to a neutral (W) for 115VAC. Always choose a neutral (W) to establish a good neutral connection when checking voltages. For additional checks, see "II.G.1. No Ice Production."

- 3) The "OUTPUT TEST" button provides a relay sequence test. Make sure the control switch is in the "ICE" position, then press the "OUTPUT TEST" button. The correct lighting sequence is 1, 4, 3, 2. Note that the order of the LEDs from the outer edge of CB is 1, 4, 3, 2. Components (e.g., compressor) will cycle during the test. Following the test, the appliance resumes operation. If the LEDs do not light as described above, replace CB.
- 4) To verify voltage output from CB to the components, slide CB K1 connector out far enough to allow multimeter lead contact. With the appliance in the cycle to be tested, check output voltage from the corresponding pin on CB K1 connector to a neutral (W). If output voltage is not found and the appropriate LED is on, replace CB.
- 5) Check CB control connectors K3, K4, and K5 for correct VDC per table below.
Note: Pin #1 is DC ground (GND) on each connector.

K3 Thermistor	
Pin #	VDC
#1 to #2	5VDC
#1 to #3	5VDC
#2 to #3	0VDC

K4 Jumper	
Pin #	VDC
#1 to #2	5VDC
#1 to #3	5VDC
#2 to #3	0VDC

K5 Float Switch	
Pin #	VDC
#1 to #2	1.2VDC
#1 to #3	2VDC
#2 to #3	1.2VDC

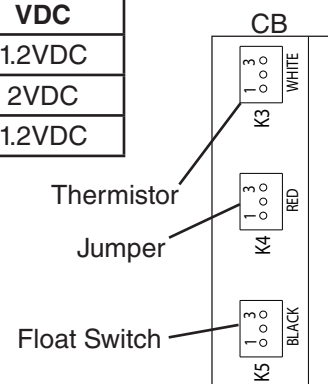

Legend: **CB**—control board; **CT**—control transformer

D. Bin Control Check

To check BC, follow the steps below.

NOTICE

When the ambient temperature is below 45°F (7°C), BC switch opens and shuts down the appliance even if the ice storage bin is empty. When BC is set in the prohibited range, the appliance operates continuously even if the ice storage bin is filled with ice. Setting in the prohibited range may result in severe damage to the appliance.

BC is factory set, and generally no adjustment is required. However, adjustment may be needed in some conditions, particularly at higher altitude locations.

Note:

- When BC switch is open, CB red "POWER OK" LED is off.
- CB yellow "BC OPEN" LED is on if CB red K4 connector does not have the jumper in place.

- 1) Turn off the power supply.
- 2) Remove the front panel, then move the control switch to the "OFF" position.
- 3) Clear any ice away from BC bulb.
- 4) Remove the control box cover, then disconnect BC wires from BC switch.
- 5) Hold your hand around BC bulb to warm it up.
- 6) Check for continuity across BC switch. If closed, continue to step 6. If open, adjust or replace BC.
- 7) With the multimeter test leads still in place, hold ice on BC bulb to lower the temperature. Within 10 sec., BC switch should open. If it remains closed, adjust or replace BC.

Legend: **BC**—bin control; **CB**—control board

E. Float Switch Check and Cleaning

FS is used to confirm sufficient water in the water tank after the 1-min. fill cycle and after each harvest cycle. FS is also used to terminate the freeze cycle. No adjustment is required.

1. Float Switch Check

To check FS, follow the steps below.

- 1) Turn off the power supply.
- 2) Remove the front panel.
- 3) Place the control switch in the "SERVICE" position. Then place the service switch in the "DRAIN" position.
- 4) Replace the front panel in its correct position, then turn on the power supply for 2 min.
- 5) Turn off the power supply.
- 6) Remove the front panel, then move the control switch to the "OFF" position.

- 7) Remove the control box cover, then disconnect FS connector from CB black K5 connector.
- 8) Check for continuity across FS leads. With the water tank empty, FS should be open. If open, continue to step 10. If closed, follow the steps in "II.E.2. Float Switch Cleaning." After cleaning FS, check it again. Replace if necessary.
- 9) Reconnect FS connector to CB black K5 connector, then replace the control box cover in its correct position.
- 10) Move the control switch to "ICE" position. Replace the front panel.
- 11) Turn on the power supply.
- 12) As water fills the water tank, FS contacts should close. After 1 min., the 1-min. fill cycle should end and the initial harvest cycle should begin. If harvest cycle doesn't start after 1 min. check continuity of FS with water tank full. If open, replace FS. If closed and harvest cycle has not started, replace CB.
- 13) Once the harvest cycle starts, turn off the power supply.
- 14) Remove the front panel, then move the control switch to the "OFF" position.
- 15) Remove the control box cover, then disconnect FS connector from CB black K5 connector.
- 16) Check for continuity across FS leads. With the water tank full, FS should be closed. If FS is closed and the appliance will not switch from the 1-min. fill cycle to the initial harvest cycle, replace CB.
- 17) If open, confirm that the water tank is full. If the water tank is not full, check the water supply, water filters, and inlet water valve. If the water tank is full, follow the steps in "II.E.2. Float Switch Cleaning." After cleaning FS, check it again. Replace if necessary.
- 18) Reconnect FS connector to CB black K5 connector, then replace the control box cover in its correct position.
- 19) Move the control switch to the "ICE" position.
- 20) Replace the front panel in its correct position.
- 21) Turn on the power supply to start the automatic icemaking process.

Legend: **CB**–control board; **FS**–float switch

2. Float Switch Cleaning

Depending on local water conditions, scale may build up on FS. Scale can cause FS to stick. In this case, FS should be cleaned.

- 1) Turn off the power supply.
- 2) Remove the front panel.
- 3) Place the control switch in the "SERVICE" position. Then place the service switch in the "DRAIN" position.
- 4) Replace the front panel in its correct position, then turn on the power supply for 2 min.
- 5) Turn off the power supply.
- 6) Remove the front, apron, top, left side panels, and side insulation, then move the control switch to the "OFF" position.
- 7) Remove FS assembly and FS stop. See Fig. 2.
- 8) Remove the retainer rod from the bottom of FS assembly, then remove the float. Be careful not to bend the retainer rod excessively when removing it.
- 9) Wipe down FS assembly's housing, shaft, float, and retainer rod with a mixture of 1 part Hoshizaki "Scale Away" and 25 parts warm water. Rinse the parts thoroughly with clean water.
- 10) Reassemble FS assembly and replace it and FS stop in their correct positions.
- 11) Replace the side insulation, left side, top, and apron panels in their correct positions.
- 12) Move the control switch to the "ICE" position.
- 13) Replace the front panel in its correct position.
- 14) Turn on the power supply to start the automatic icemaking process.

Legend: **CB**—control board; **FS**—float switch

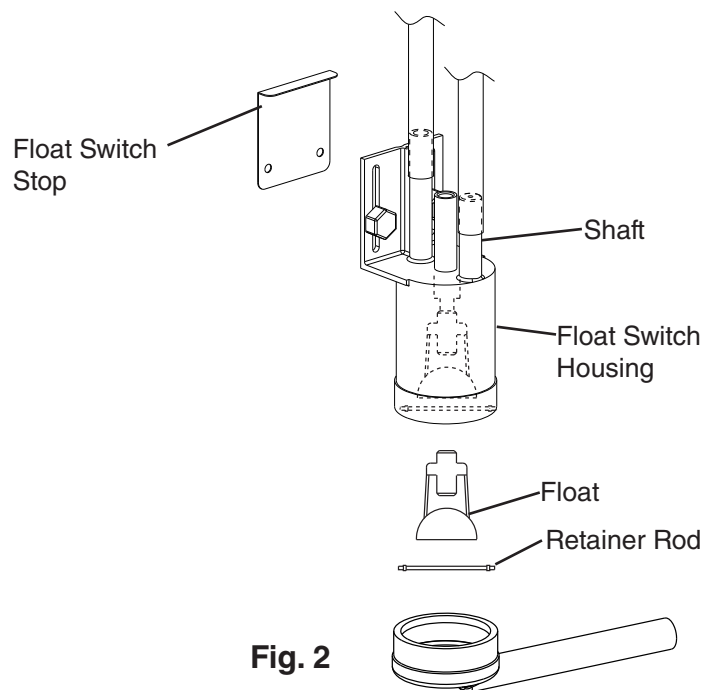

Fig. 2

F. Thermistor Check

To check thermistor resistance, follow the steps below.

- 1) Turn off the power supply.
- 2) Remove the front panel, then move the control switch to the "OFF" position.
- 3) Remove the control box cover.
- 4) Remove the thermistor.
- 5) Immerse the thermistor sensor portion in a glass containing ice and water for 2 or 3 min.
- 6) Disconnect the thermistor connector from CB white K3 connector and check resistance between thermistor leads. Normal range is 4.7 to 6.2 k Ω . If outside the normal range, replace the thermistor. See "V.B. Component Information." If within the normal range, continue to next step.
- 7) Replace the thermistor in its correct position. See "IV.B. Component Service Information."
- 8) Reconnect the thermistor connector to CB white K3 connector.
- 9) Replace the control box cover in its correct position.
- 10) Move the control switch to the "ICE" position.
- 11) Replace the front panel in its correct position.
- 12) Turn on the power supply.
- 13) Once the harvest cycle starts (Comp energizes), begin timing the harvest cycle.
- 14) The harvest timer and harvest cycle should terminate within 2 to 5 min. If the harvest cycle does not terminate within 2 to 5 min., replace CB.

Legend: **CB**—control board; **Comp**—compressor

G. Diagnostic Tables

Before consulting the diagnostic tables, check for correct installation, proper voltage per nameplate, and adequate water pressure (10 to 113 PSIG). Check control board using the steps in "II.C. Control Board Check."

1. No Ice Production

No Ice Production - Possible Cause	
1. Power Supply	a) Off, blown fuse, or tripped breaker.
	b) Not within specifications.
2. Main Transformer (3 phase SRK) (208-230VAC/115VAC)	a) Voltage tap switch not set to proper voltage.
	b) No neutral. W to ground 0VAC. (W to ground should be 60VAC).
3. Water Supply	a) Water supply off or improper water pressure.
	b) External water filters clogged.
4. Fuse (SRK Control Box)	a) Blown.
5. High-Pressure Switch (SRK)	a) Dirty condenser.
	b) Condensing unit fan(s) not operating.
	c) Headmaster (C.P.R.) open.
	d) Refrigerant overcharged.
	e) Bad contacts.
	f) Refrigerant lines or components plugged.
6. Discharge Line Thermostat (SRK)	a) Ambient temperature too warm.
	b) Compressor or compressor components faulty.
	c) Defective.
	d) Hot gas valves open.
	e) Dirty condenser.
	f) Condensing unit fan(s) not operating.
7. Wire Harness (From SRK to KMS)	a) Disconnected or loose connection.
8. Fuse (KMS Control Box)	a) Blown.
9. Control Switch	a) In "SERVICE" or "OFF" position.
	b) Bad contacts.
10. Control Transformer (115VAC/10.5VAC)	a) Coil winding open or shorted.
11. Bin Control See "II.D. Bin Control Check"	a) Tripped with bin filled with ice.
	b) Ambient temperature too cool.
	c) Bulb out of position.
	d) Set too warm.
	e) Defective.
12. Control Board See "II.C. Control Board Check"	a) In alarm.
	b) Yellow "BC OPEN" LED on (jumper loose or missing).
	c) Defective.
13. Inlet Water Valve	a) Screen or orifice clogged.
	b) Coil winding open.
	c) Water valve open in freeze cycle.

No Ice Production - Possible Cause	
14. Float Switch See "II.E. Float Switch Check and Cleaning"	a) Float does not move freely.
	b) Defective.
15. Compressor	a) Magnetic contactor contacts bad or coil winding open.
	b) Start capacitor or run capacitor defective (1 phase SRK).
	c) Start relay contacts bad or coil winding open (1 phase SRK).
	d) Internal protector open.
	e) Compressor defective.
16. Hot Gas Valves (KMS & SRK)	a) Closed in harvest cycle.
	b) Open in freeze cycle.
17. Thermistor See "II.F. Thermistor Check"	a) Loose, disconnected, or defective.
18. Pump Motor	a) Motor winding open.
	b) Bearing worn out or locked rotor.
	c) Defective capacitor.
19. Thermostatic Expansion Valve	a) Bulb loose.
	b) Operating erratically.
20. Liquid Line Valves (KMS & SRK)	a) Closed in freeze cycle.
	b) Open in harvest cycle.
21. Fan Motors-Remote	a) Motor winding open.
	b) Bearing worn out or locked rotor.
	c) Defective capacitor.
22. Headmaster	a) Defective.
23. Water System	a) Water leaks causing short freeze time.

2. Freeze-Up

Defrost and clean the icemaker prior to diagnosing freeze-up. Fill out a freeze-up checklist. The freeze-up checklist can be found in the Hoshizaki Technician's Pocket Guide or contact your local distributor for a copy of the freeze-up checklist.

Freeze-Up - Possible Cause	
Harvest Cycle	
1. Evaporator	a) Scaled up.
	b) Damaged.
2. Cube Guides	a) Out of position.
	b) Damaged.
3. Spray Tubes and/or Spray Guides	a) Dirty.
	b) Out of position.
4. Water Supply	a) Low water pressure.
	b) External water filters clogged.
	c) Insufficient water line size. Minimum 3/8" nominal ID copper water tubing or equivalent.
5. Inlet Water Valve	a) Defective.

Freeze-Up - Possible Cause	
6. Float Switch See "II.E. Float Switch Check and Cleaning"	a) Float does not move freely.
	b) Defective.
7. Refrigerant Charge	a) Low.
8. Control Board See "III. Controls and Adjustments" and "II.C. Control Board Check"	a) Harvest timer (S4 dip switch 1 & 2) set too short.
	b) Harvest pump timer (S4 dip switch 7) not in factory default position.
	c) Defective.
9. Bin Control See "II.D. Bin Control Check"	a) Bulb out of position.
	b) Defective.
10. Thermistor See "II.F. Thermistor Check"	a) Loose, disconnected, or defective.
11. Thermostatic Expansion Valve	a) Defective.
12. Hot Gas Valves (KMS & SRK)	a) Closed or restricted.
13. Liquid Line Valves (KMS & SRK)	a) Open.
Freeze Cycle	
1. Evaporator	a) Scaled up.
	b) Damaged.
2. Spray Tubes and/or Spray Guides	a) Dirty.
	b) Out of position.
3. Refrigerant Charge	a) Low.
4. Control Board See "II.C. Control Board Check"	a) Freeze timer (S4 dip switch 9 & 10) set incorrectly.
	b) Defective.
5. Inlet Water Valve	a) Leaking by.
6. Float Switch See "II.E. Float Switch Check and Cleaning"	a) Float does not move freely.
	b) Defective.
7. Pump Motor	a) RPM too slow.
	b) Impeller damaged.
8. Thermostatic Expansion Valve	a) Bulb loose or defective.
9. Headmaster	a) Defective.
10. Liquid Line Valves (KMS & SRK)	a) Restricted.

3. Low Ice Production

Low Ice Production - Possible Cause	
Long Harvest Cycle	
1. Evaporator	a) Scaled up.
2. Spray Tubes and/or Spray Guides	a) Dirty.
	b) Out of position.
3. Refrigerant Charge	a) Low.
4. Water Supply	a) Low water pressure.
	b) External water filters clogged.
	c) Insufficient water line size. Minimum 3/8" nominal ID copper water tubing or equivalent.
	d) Too cold.
5. Control Board See "II.C. Control Board Check"	a) Thermistor connection loose (K3).
	b) Defective.
6. Thermistor See "II.F. Thermistor Check"	a) Loose, disconnected, or defective.
7. Hot Gas Valves (KMS & SRK)	a) Erratic or closed.
8. Inlet Water Valve	a) Screen or orifice clogged.
9. Compressor	a) Inefficient or off.
10. Liquid Line Valves (KMS & SRK)	a) Erratic or open.
11. Thermostatic Expansion Valve (TXV)	a) Defective.
12. Headmaster	a) Defective.
Long Freeze Cycle	
1. Evaporator	a) Scaled up, dirty.
2. Float Switch See "II.E. Float Switch Check and Cleaning"	a) Scaled up, dirty.
	b) Float sticking.
	c) Defective switch.
3. Inlet Water Valve	a) Leaking by.
4. Hot Gas Valves (KMS & SRK)	a) Erratic or open.
5. Condenser	a) Clogged.
6. Control Board See "II.C. Control Board Check"	a) Float switch connection loose (K5).
	b) Defective.
7. Refrigerant Charge	a) Low.
8. Thermostatic Expansion Valve (TXV)	a) Bulb loose.
	b) Defective.
9. Compressor	a) Inefficient or off.
10. Pump Motor	a) RPM too slow.
11. Liquid Line Valves (KMS & SRK)	a) Erratic or restricted.
12. Headmaster	a) Defective.

III. Controls and Adjustments

- A Hoshizaki exclusive control board is employed in the KMS-1122MLH series.
- All models are pretested and factory adjusted.
- For a control board check procedure, see "II.C. Control Board Check."

<i>NOTICE</i>
<ul style="list-style-type: none">• Fragile, handle very carefully.• The control board contains integrated circuits, which are susceptible to failure due to static discharge. It is especially important to touch the metal part of the appliance when handling or replacing the control board.• Do not touch the electronic devices on the control board or the back of the control board.• Do not change wiring and connections. Do not misconnect terminals.• Do not short out power supply to test for voltage.• Always replace the whole control board assembly if it goes bad.

A. Control Board Layout

"G" Control Board

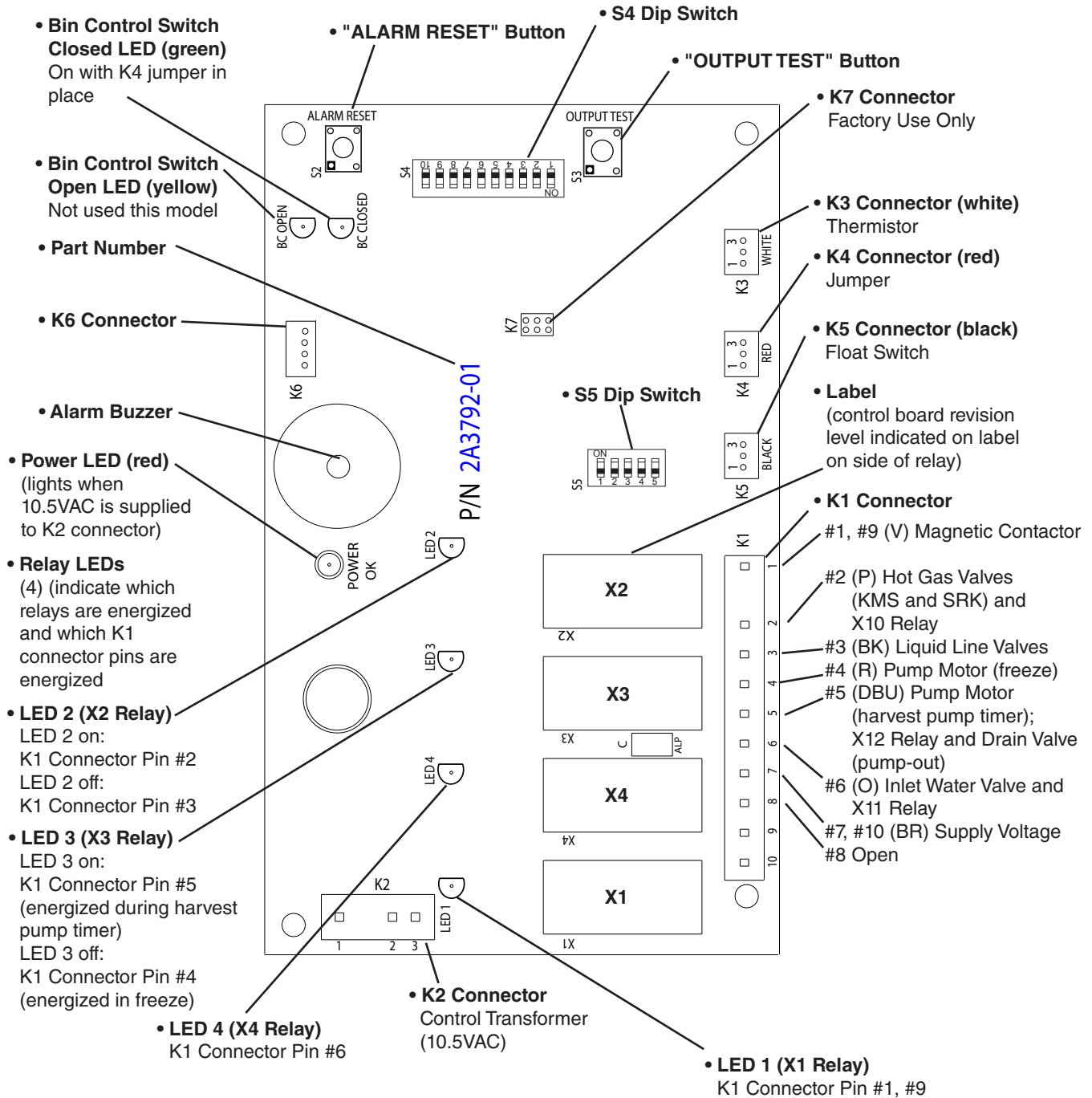

"G" Control Board	
Part Number	2A3792-01

B. LED Lights and Audible Alarm Safeties

At startup, a 5-sec. delay occurs while CB conducts an internal timer check. A beep occurs when the control switch (KMS) is moved to the "ICE" position. The red "POWER OK" LED indicates proper control voltage and remains on unless a control voltage problem occurs. The green LEDs 1 through 4 energize and sequence from initial startup as listed in the table below. Note that the order of the LEDs from the outer edge of the control board is 1, 4, 3, 2. For details, see "II.C. Control Board Check."

LED Lights and Components					
Sequence Step	LED	Energized Components	Time LEDs are On		
			Min.	Max.	Avg.
1-Minute Fill Cycle	4	WV			1 min.
Harvest Cycle	1, 4, 2	Comp, FMRs WV, HGVs	2 min.	20 min.	3 to 5 min.
Harvest Pump Timer	1, 3, 2	Comp, FMRs, PM, HGVs	0 sec.	50 sec.	harvest pump timer setting
Freeze Cycle	1	Comp, FMRs, PM, LLVs	5 min.	freeze timer setting	30 to 35 min.
Pump-Out Cycle	1, 3, 2	Comp, FMRs, PM, HGVs, DV	10 sec.	20 sec.	

Built in safeties shut down the appliance and have alarms as listed below.

Manual Reset Alarm Safeties		
To reset, press CB "ALARM RESET" button with the power supply on.		
WARNING! Risk of electric shock. Care should be taken not to touch live terminals.		
No. of Beeps (every 3 sec.)	Type of Alarm	Notes
1	High Evaporator Temp. (temperature > 127°F (53°C))	Check for harvest problem (stuck HGVs or relay), hot water entering icemaker, stuck HM, or shorted thermistor.
2	Harvest Backup Timer (harvest > 20 min. for two cycles in a row)	Check for open thermistor, HGVs not opening, TXVs or LLVs leaking by, low charge, or inefficient Comp.
3	Freeze Timer (freeze > specified setting for two cycles in a row) Timer is factory set using S4 dip switch 9 & 10	Check for FS stuck closed (up), WV leaking by, HGVs leaking by, PM not pumping, TXVs not feeding properly, LLVs not opening, low charge, HM not bypassing, or inefficient compressor.
Automatic Reset Alarm Safeties		
Automatically reset when voltage returns to acceptable range.		
6	Low Voltage (92VAC±5% or less)	Red "POWER OK" LED will turn off if voltage protection operates.
7	High Voltage (147VAC±5% or more)	

Legend: **CB**—control board; **Comp**—compressor; **DV**—drain valve; **FMRs**—fan motors-remote; **FS**—float switch; **HGVs**—hot gas valves; **HM**—headmaster; **LLVs**—liquid line valves; **PM**—pump motor; **TXVs**—thermostatic expansion valves; **WV**—inlet water valve

C. Settings and Adjustments

NOTICE

Dip switches are factory set. Failure to maintain factory settings may adversely affect performance and warranty coverage. For more information, contact Hoshizaki Technical Support at 1-800-233-1940.

1. Default Dip Switch Settings

The dip switches are factory-adjusted to the following positions:

S4 Dip Switch										
Dip Switch No.	1	2	3	4	5	6	7	8	9	10
KMS-1122MLH	OFF	OFF	OFF	OFF	ON	ON	ON	OFF	OFF	OFF

S5 Dip Switch (Do Not Adjust)					
Dip Switch No.	1	2	3	4	5
KMS-1122MLH	OFF	OFF	OFF	OFF	OFF

S4 Dip Switch

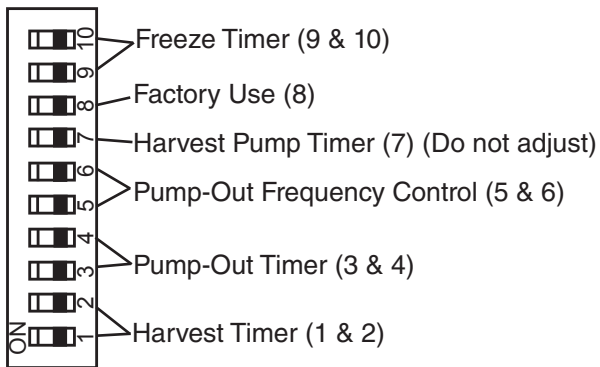

S5 Dip Switch

Do Not Adjust

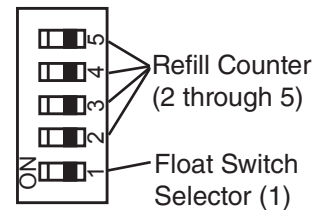

2. Harvest Timer (S4 dip switch 1 & 2)

The harvest timer starts counting when the thermistor reaches 48°F (9°C) at the evaporator outlet and the control board reads 3.9 kΩ from the thermistor. The harvest timer is factory set, and generally no adjustment is required. However, a setting longer than the factory setting may be advised in cases where harvest needs to be prolonged for extra cleaning. Before changing this setting, contact your local Hoshizaki distributor or Hoshizaki Technical Support for recommendations. Keep in mind that setting the harvest timer to a longer setting decreases 24-hr production. The pump-out timer (S4 dip switch 3 & 4) acts in place of the harvest timer during cycles with a pump-out. For details, see "III.C.3. Pump-Out Timer (S4 dip switch 3 & 4)" below.

Dip Switch Setting		Time (sec.)
No. 1	No. 2	
OFF	OFF	60
ON	OFF	90
OFF	ON	120
ON	ON	180

3. Pump-Out Timer (S4 dip switch 3 & 4)

NOTICE

Factory set for proper operation. Do not adjust S4 dip switch 3 & 4 to 3 off and 4 on. Otherwise, drain valve does not energize in pump out.

The 1st pump-out occurs after the 11th freeze cycle, then every 10th cycle thereafter. When a pump-out is called for, the pump motor stops for 2 sec. then the X12 drain valve relay energizes, allowing the pump motor and drain valve to energize. Water is removed from the bottom of the water tank and sent down the drain. The pump-out drains the water tank for the time determined by the pump-out timer. The pump-out timer also acts in place of the harvest timer during cycles with a pump-out. The pump-out timer is factory set, and generally no adjustment is required. The pump-out timer can be set for a 10 or 20 sec. pump out.

S4 Dip Switch Setting		Time (sec.)		Inlet Water Valve
No. 3	No. 4	T1	T2	
OFF	OFF	10	150	closed
ON	OFF	10	180	closed
OFF	ON	10	120	open if refill = 0; closed if refill 1 or greater
ON	ON	20	180	closed

T1: Time to drain the water tank

T2: Harvest timer at pump-out

4. Pump-Out Frequency Control (S4 dip switch 5 & 6)

The pump-out frequency control is factory-adjusted to drain the water tank every 10 cycles, and generally no adjustment is required. However, where water quality is bad and the appliance needs a more frequent pump-out, the pump-out frequency can be adjusted as shown in the table below.

Timing of the first pump-out is dependent on S4 dip switch 5 & 6 settings. See the table below.

S4 Dip Switch Setting		Pump-Out Frequency	1st Pump-Out
No. 5	No. 6		
OFF	OFF	Every cycle	After 2nd freeze cycle
ON	OFF	Every 2 cycles	After 3rd freeze cycle
OFF	ON	Every 5 cycles	After 6th freeze cycle
ON	ON	Every 10 cycles	After 11th freeze cycle

5. Harvest Pump Timer (S4 dip switch 7)

NOTICE
Factory set for proper operation. Do not adjust. Adjustment outside of the factory default setting may result in damage to the appliance.

When S4 dip switch 7 is in the on position and harvest begins, X11 and X10 relays energize. A latching circuit is created through the X11 and X10 relays. This prevents the drain valve from energizing. For further details, see "VIII.C. Wiring Diagrams." 50 sec. before harvest termination, LED 4 turns off, inlet water valve and X11 relay de-energize. X10 relay remains energized through the latching circuit. Next, LED 3 turns on and control board K1 connector pin #5 (DBU wire) energizes and the pump motor energizes for the last 50 sec. of harvest. The inlet water valve and X11 relay are energized during harvest for a maximum of 6 min. or the length of harvest minus 50 sec., whichever is shorter.

S4 Dip Switch Setting	Pump Motor Time (sec.)
No. 7	
ON	50
OFF	0

6. Factory Use (S4 dip switch 8)

Factory set for proper operation.

NOTICE
Do not adjust. This must be left in the factory default position.

7. Freeze Timer (S4 dip switch 9 & 10)

NOTICE

Adjust to proper specification, or the icemaker may not operate correctly.

The freeze timer setting determines the maximum allowed freeze time to prevent possible freeze-up issues. Upon termination of the freeze timer, the control board initiates the harvest cycle. After 2 consecutive freeze timer terminations, the control board shuts down the appliance. In this case, see "II.G.3. Low Ice Production" for possible solutions.

The freeze timer is factory set, and generally no adjustment is required. Before changing this setting, contact your local Hoshizaki distributor or Hoshizaki Technical Support for recommendations.

Dip Switch Setting		Time (min.)
No. 9	No. 10	
OFF	OFF	60
OFF	ON	50
ON	OFF	70
ON	ON	60

8. Float Switch Selector (S5 dip switch 1)

NOTICE

Do not adjust. This must be left in the factory default position or the appliance will not operate correctly.

On appliances with a double float switch, the float switch selector determines which float switch (upper or lower) the control board monitors for refill initiation during the freeze cycle. The refill counter (S5 dip switch 2 through 5) determines the number of refills. The KMS-1122MLH uses a single float switch and does not refill during the freeze cycle.

S5 Dip Switch Setting	Float Switch Type	Refill Initiation with Double Float Switch
No. 1		
OFF	Single or Double	Lower Float Switch
ON	Double	Upper Float Switch

9. Refill Counter (S5 dip switch 2 through 5)

NOTICE

Do not adjust. These must be left in the factory default position or the appliance will not operate correctly.

Factory set. S5 dip switch 2 through 5 allows for refills during the freeze cycle. The KMS-1122MLH does not refill. Do not adjust.

S5 Dip Switch Setting				No. of Refills
No. 2	No. 3	No.4	No. 5	
OFF	OFF	OFF	OFF	0 Refills

Note: When refill set > 0, water valve is off during pump-out even if S4 dip switch 3 & 4 are set to 3 off and 4 on. See "III.C.3. Pump-Out Timer (S4 dip switch 3 & 4)."

D. Control Switch and Service Switch

2 switches are used to control the operation of the appliance. These switches are referred to as the control switch and service switch. They are located on the KMS control box.

1. Control Switch

The control switch has three positions: "OFF" for power off, "ICE" for icemaking, and "SERVICE" to activate the service switch.

2. Service Switch

When the control switch is in the "SERVICE" position, the control switch supplies power to the service switch and water pump. The service switch has three positions: "DRAIN," "CIRCULATE," and "WASH."

Note:

1. When the service switch is active (control switch in the "SERVICE" position), power is supplied to the water pump in all three positions.
2. When the control switch is in the "OFF" or "ICE" position, the service switch is de-activated. In this state, it can be left in any position.

a) DRAIN

The appliance utilizes a pump-out drain system. When the control switch is in the "SERVICE" position and the service switch is placed in the "DRAIN" position, power is supplied to the water pump and drain valve.

b) CIRCULATE

When the service switch is active and placed in the "CIRCULATE" position, power is supplied to the water pump only. This setting is used during cleaning to circulate cleaner for extended periods of time over the outside surface of the evaporator.

c) WASH

The appliance utilizes a solenoid operated cleaning valve. When the service switch is active and placed in the "WASH" position, power is supplied to the pump motor and cleaning valve. This operation is used to circulate cleaner and sanitizer over both the inside and outside of the evaporator.

IV. Refrigeration Circuit and Component Service Information

⚠ WARNING

- This appliance should be diagnosed and repaired only by qualified service personnel to reduce the risk of death, electric shock, serious injury, or fire.
- Before servicing the KMS or SRK: Move the KMS control switch to the "OFF" position and turn off the power supply to the SRK condensing unit. Place the KMS disconnect (if applicable) in the "OFF" position. Lockout/Tagout to prevent the power supply from being turned back on inadvertently.
- **CHOKING HAZARD:** Ensure all components, fasteners, and thumbscrews are securely in place after the icemaker is serviced. Make sure that none have fallen into the dispenser unit/ice storage bin.
- Make sure all food zones in the icemaker and dispenser unit/ice storage bin are clean after service.

A. Refrigeration Circuit Service Information

⚠ WARNING

- Repairs requiring the refrigeration circuit to be opened must be performed by properly trained and EPA-certified service personnel.
- Use an electronic leak detector or soap bubbles to check for leaks. Add a trace of refrigerant to the system (if using an electronic leak detector), and then raise the pressure using nitrogen gas (140 PSIG). Do not use R-404A as a mixture with pressurized air for leak testing.

NOTICE

- Always recover the refrigerant and store it in an approved container. Do not discharge the refrigerant into the atmosphere.
- Do not leave the system open for longer than 15 min. when replacing or servicing parts. The Polyol Ester (POE) oils used in R-404A applications can absorb moisture quickly. Therefore it is important to prevent moisture from entering the system when replacing or servicing parts.
- Always install a new drier every time the sealed refrigeration system is opened. Do not replace the drier until after all other repair or replacement has been made. Install the new drier with the arrow on the drier in the direction of the refrigerant flow.
- When brazing, protect the drier by using a wet cloth to prevent the drier from overheating. Do not allow the drier to exceed 250°F (121°C).

1. Refrigerant Recovery

The condensing unit is provided with refrigerant shutoff valves and the icemaker is provided with refrigerant service valves. Using proper refrigerant practices, recover the refrigerant. Recovery via the condensing unit's refrigerant shutoff valves is recommended. Store the refrigerant in an approved container. Do not discharge the refrigerant into the atmosphere.

2. Brazing

⚠ WARNING

- R-404A itself is not flammable at atmospheric pressure and temperatures up to 176°F (80°C).
- R-404A itself is not explosive or poisonous. However, when exposed to high temperatures (open flames), R-404A can be decomposed to form hydrofluoric acid and carbonyl fluoride both of which are hazardous.
- Do not use silver alloy or copper alloy containing arsenic.

- 1) Braze all fittings while purging with nitrogen gas flowing at a pressure of 3 to 4 PSIG.
Note: Because the pipes in the evaporator case are specially coated to resist corrosion, it is important to make connections outside the evaporator case when possible. If it is necessary to braze inside the evaporator case, use sandpaper to remove the coating from the brazing connections before unbrazing the components.

NOTICE

- Always install a new drier every time the sealed refrigeration system is opened.
- Do not replace the drier until after all other repair or replacement has been made. Install the new drier with the arrow on the drier in the direction of the refrigerant flow.
- When brazing, protect the drier by using a wet cloth to prevent the drier from overheating. Do not allow the drier to exceed 250°F (121°C).

- 2) Use an electronic leak detector or soap bubbles to check for leaks. Add a trace of refrigerant to the system (if using an electronic leak detector), and then raise the pressure using nitrogen gas (140 PSIG). Do not use R-404A as a mixture with pressurized air for leak testing.

3. Evacuation and Recharge (R-404A)

The condensing unit is provided with refrigerant shutoff valves and the icemaker is provided with refrigerant service valves. Evacuation and recharge via the condensing unit's refrigerant shutoff valves is recommended.

- 1) Attach a vacuum pump to the system. Be sure to connect the charging hoses to both high and low-side refrigerant shutoff valves.

IMPORTANT

The vacuum level and vacuum pump may be the same as those for current refrigerants. However, the rubber hose and gauge manifold to be used for evacuation and refrigerant charge should be exclusively for POE oils.

- 2) Turn on the vacuum pump. Open the gauge manifold valves, then open the high and low-side refrigerant shutoff valves. Never allow the oil in the vacuum pump to flow backwards.

- 3) Allow the vacuum pump to pull down to a 29.9" Hg vacuum. Evacuating period depends on pump capacity.
- 4) Close the low-side valve and high-side valve on the gauge manifold.
- 5) Disconnect the gauge manifold hose from the vacuum pump and attach it to a refrigerant service cylinder. Remember to loosen the connection and purge the air from the hose. For the required refrigerant charge, see the nameplate on the condensing unit or the rating label inside the icemaker. Hoshizaki recommends only virgin refrigerant or reclaimed refrigerant which meets ARI Standard 700 (latest edition) be used.
- 6) A liquid charge is required when charging an R-404A system (to prevent fractionation). Place the service cylinder on the scales; if the service cylinder is not equipped with a dip tube, invert the service cylinder, then place it on the scales. Open the high-side valve on the gauge manifold.
- 7) Allow the system to charge with liquid until the proper charge weight is met.
- 8) If necessary, add any remaining charge to the system through the low-side.
NOTICE! To prevent compressor damage, use a throttling valve or liquid dispensing device to add the remaining liquid charge through the low-side refrigerant shutoff valve with the icemaker running.
- 9) Close the high and low-side refrigerant shutoff valves. Close the high and low-side gauge manifold valves, then disconnect the gauge manifold hoses.
- 10) Cap the refrigerant shutoff valves to prevent a possible leak.

B. Component Service Information

NOTICE

When replacing a component listed below, see the notes to help ensure proper operation.

Component	Notes
Compressor	1 Phase SRK: Install a new start capacitor, run capacitor, and start relay. 3 Phase SRK: Install a new magnetic contactor.
Thermostatic Expansion Valves	<ul style="list-style-type: none"> • Attach the thermostatic expansion valve bulb to the suction line in the same location as the previous bulb. • The bulb should be between the 10 and 2 o'clock positions on the tube. • Secure the bulb with the clamp and holder, then insulate it.
Hot Gas Valves Liquid Line Valves	<ul style="list-style-type: none"> • Replace the strainer if applicable. • Use copper tube of the same diameter and length when replacing valve lines.
Fan Motors	Install a new capacitor.
Pump Motor	Install a new capacitor.
Thermistor	<ul style="list-style-type: none"> • Attach the new thermistor to the suction line in the same location as the previous thermistor. • The thermistor should be at the 12 o'clock position on the tube. • Smoothly fill the recessed area of the thermistor holder with high thermal conductive type sealant. Hoshizaki America part number 4A0683-01 (Silicone Heat Sink Compound 10-8108 manufactured by GC Electronics), KE-4560 RTV (manufactured by ShinEtsu Silicones), or equivalent are recommended. • Secure the thermistor with the holder, then insulate it. • Be very careful to prevent damage to the leads.

V. Maintenance

The maintenance schedule below is a guideline. More frequent maintenance may be required depending on water quality, the appliance's environment, and local sanitation regulations

WARNING

- Only qualified service technicians should service the appliance.
- To reduce the risk of electric shock, do not touch the control switch or service switch with damp hands
- Before servicing the KMS or SRK: Move the KMS control switch to the "OFF" position and turn off the power supply to the SRK condensing unit. Place the KMS disconnect (if applicable) in the "OFF" position. Lockout/Tagout to prevent the power supply from being turned back on inadvertently.
- **CHOKING HAZARD:** Ensure all components, fasteners, and thumbscrews are securely in place after any maintenance is done to the icemaker. Make sure that none have fallen into the dispenser unit/ice storage bin.

Maintenance Schedule

Frequency	Area	Task
Daily	Scoop	Clean the ice scoop using a neutral cleaner. Rinse thoroughly after cleaning.
Monthly	External Water Filters	Check for proper pressure and change if necessary.
	Icemaker Exterior	Wipe down with a clean, soft cloth. Use a damp cloth containing a neutral cleaner to wipe off oil or dirt build up. Clean any chlorine staining (rust colored spots) using a non-abrasive cleanser.
Yearly	Icemaker and Dispenser Unit/Ice Storage Bin Liner	Clean and sanitize per the cleaning and sanitizing instructions provided in the instruction manual or maintenance label on the icemaker.
	Water Supply Inlet	Close the icemaker water supply line shut-off valve and drain the water system. Clean the water supply inlet screen.
	Condenser	Inspect. Clean if necessary by using a brush or vacuum cleaner. More frequent cleaning may be required depending on location.
	Water Hoses	Inspect the water hoses and clean/replace if necessary.

VI. Preparing the Appliance for Periods of Non-Use

NOTICE
<ul style="list-style-type: none">• When storing the appliance for an extended time or in sub-freezing temperatures, follow the instructions below to prevent damage.• To prevent damage to the water pump, do not operate the appliance with the control switch in the "SERVICE" position when the water tank is empty.

When the appliance is not used for two or three days under normal conditions, it is sufficient to move the control switch to the "OFF" position. When storing the appliance for an extended time or in sub-freezing temperatures, follow the instructions below.

1. Remove the water from the icemaker water line:

- 1) Turn off the power supply, then remove the front panel.
- 2) Close the icemaker water supply line shut-off valve and open the icemaker water supply line drain valve.
- 3) Allow the line to drain by gravity.
- 4) Attach a compressed air or carbon dioxide supply to the icemaker water supply line drain valve.
- 5) Make sure at least 3 min. have elapsed since you turned off the power supply. Make sure the control switch is in the "ICE" position. Replace the front panel in its correct position, then turn on the power supply.
- 6) Blow the icemaker water supply line out using the compressed air or carbon dioxide supply.
- 7) Close the icemaker water supply line drain valve.

2. Remove the water from the water tank:

- 1) Turn off the power supply.
- 2) Remove the front, apron, top, left side, and side insulation panels.
- 3) Move the control switch to the "OFF" position.
- 4) Remove the drain plug. Allow the water tank to drain.
- 5) Replace the drain plug in its correct position. Be careful not to cross thread the drain plug.
- 6) Replace the side insulation, left side, top, apron, and front panels in their correct positions.
- 7) Remove all ice from the dispenser unit/ice storage bin. Clean the dispenser unit/ice storage bin using a neutral cleaner. Rinse thoroughly after cleaning.

VII. Disposal

The appliance contains refrigerant and must be disposed of in accordance with applicable national, state, and local codes and regulations. Refrigerant must be recovered by properly certified service personnel.

VIII. Technical Information

A. Specification Sheets

1. KMS-1122MLH with SRK-12H

AC SUPPLY VOLTAGE	115VAC Supplied by SRK-12H via Factory Supplied Wire Harness			
APPROXIMATE ICE PRODUCTION PER 24 HR. lb./day (kg/day) Reference without *marks	Ambient Temp.(°F)	WATER TEMP. (°F)		
		50	70	90
	70	*1100 (499)	1066 (484)	999 (453)
	80	1074 (487)	1022 (464)	943 (428)
	90	1066 (484)	*985 (447)	910 (413)
	100	1046 (474)	967 (439)	841 (381)
SHAPE OF ICE	Crescent Cube			
ICE PRODUCTION PER CYCLE	17 lb. (7.7 kg) 880pcs.			
ELECTRIC & WATER CONSUMPTION	90/70°F	70/50°F		
KMS/SRK COMBINED ELECTRIC W (kWH/100 lb.)	1910(4.65)	1830(4.00)		
WATER gal./24HR (gal./100 lb.)	192(19.5)	473(43.0)		
ENERGY STAR (2.0)	YES			
EXTERIOR DIMENSIONS (WxDxH)	22"x18"(base)x31.25" (559x457x794 mm)			
EXTERIOR FINISH	Stainless Steel, Stainless Steel (Rear)			
WEIGHT	Net 116 lb. (53 kg), Shipping 150 lb. (68 kg)			
CONNECTIONS - ELECTRIC	Wire Harness Connection from SRK to KMS			
- WATER SUPPLY	Inlet	1/2" FPT		
- DRAIN	Outlet	3/4" FPT		
-REFRIGERATION	Liquid Line	1 1/16 - 12 UNF FITTING (#10 PARKER)		
	Suction Line	1 1/8 - 12 UNF FITTING (#11 PARKER)		
CUBE CONTROL SYSTEM	Float Switch			
HARVESTING CONTROL SYSTEM	Hot Gas and Water, Thermistor and Timer			
ICE MAKING WATER CONTROL	Timer Controlled, Overflow Pipe, and Float Switch			
COOLING WATER CONTROL	N/A			
BIN CONTROL SYSTEM	Thermostatic			
COMPRESSOR	In SRK			
CONDENSER	Air-Cooled Remote Condensing Unit SRK-12H			
EVAPORATOR	Vertical Type, Stainless Steel and Copper			
REFRIGERANT CONTROL	Thermostatic Expansion Valve			
REFRIGERANT CHARGE	Headmaster (C.P.R.) in SRK-12H (160 PSI) R404A, 16 lb. 5 oz. (7400g) (Icemaker 0 lb. 7.1 oz. (200g)) (Cond. Unit 15 lb. 14 oz. (7200g))			
DESIGN PRESSURE	High 467PSIG, Low 230PSIG			
CONTROL BOARD CIRCUIT PROTECTION	High Voltage Cut-Out (Internal)			
REFRIGERANT CIRCUIT PROTECTION	Auto-Reset High-Pressure Switch in SRK-12H Auto-Reset Discharge Line Thermostat in SRK-12H			
LOW WATER PROTECTION	Float Switch			
ACCESSORIES -SUPPLIED	N/A			
-REQUIRED	Dispenser Unit or Ice Storage Bin SRK-12H Remote Condensing Unit			
OPERATING CONDITIONS	VOLTAGE RANGE (SRK-12H)	187-253VAC		
	AMBIENT TEMP.	45-100°F		
	WATER SUPPLY TEMP.	45-90°F		
	WATER SUPPLY PRESSURE	10-113 PSIG		

Note: We reserve the right to make changes in specifications and design without prior notice.

2. KMS-1122MLH with SRK-12H3

AC SUPPLY VOLTAGE	115VAC Supplied by SRK-12H3 via Factory Supplied Wire Harness			
APPROXIMATE ICE PRODUCTION PER 24 HR. lb./day (kg/day) Reference without *marks	Ambient Temp.(°F)	WATER TEMP. (°F)		
		50	70	90
	70	*1120 (508)	1085 (492)	1016 (461)
	80	1093 (496)	1039 (471)	958 (435)
	90	1085 (492)	*1000 (454)	923 (419)
	100	1064 (483)	982 (445)	852 (386)
SHAPE OF ICE	Crescent Cube			
ICE PRODUCTION PER CYCLE	17.1 lb. (7.7 kg) 880pcs.			
ELECTRIC & WATER CONSUMPTION	90/70°F	70/50°F		
KMS/SRK COMBINED ELECTRIC W (kWH/100 lb.)	1920(4.60)	1790(3.83)		
WATER gal./24HR (gal./100 lb.)	195(19.5)	451(40.3)		
ENERGY STAR (2.0)	YES			
EXTERIOR DIMENSIONS (WxDxH)	22"x18"(base)x31.25" (559x457x794 mm)			
EXTERIOR FINISH	Stainless Steel, Stainless Steel (Rear)			
WEIGHT	Net 116 lb. (53 kg), Shipping 150 lb. (68 kg)			
CONNECTIONS - ELECTRIC	Wire Harness Connection from SRK to KMS			
- WATER SUPPLY	Inlet	1/2" FPT		
- DRAIN	Outlet	3/4" FPT		
-REFRIGERATION	Liquid Line	1 1/16 - 12 UNF FITTING (#10 PARKER)		
	Suction Line	1 1/8 - 12 UNF FITTING (#11 PARKER)		
CUBE CONTROL SYSTEM	Float Switch			
HARVESTING CONTROL SYSTEM	Hot Gas and Water, Thermistor and Timer			
ICE MAKING WATER CONTROL	Timer Controlled, Overflow Pipe, and Float Switch			
COOLING WATER CONTROL	N/A			
BIN CONTROL SYSTEM	Thermostatic			
COMPRESSOR	In SRK			
CONDENSER	Air-Cooled Remote Condensing Unit SRK-12H3			
EVAPORATOR	Vertical Type, Stainless Steel and Copper			
REFRIGERANT CONTROL	Thermostatic Expansion Valve			
	Headmaster (C.P.R.) in SRK-12H3 (160 PSI)			
REFRIGERANT CHARGE	R404A, 16 lb. 5 oz. (7400g) (Icemaker 0 lb. 7.1 oz. (200g)) (Cond. Unit 15 lb. 14 oz. (7200g))			
DESIGN PRESSURE	High 467PSIG, Low 230PSIG			
CONTROL BOARD CIRCUIT PROTECTION	High Voltage Cut-Out (Internal)			
REFRIGERANT CIRCUIT PROTECTION	Auto-Reset High-Pressure Switch in SRK-12H3 Auto-Reset Discharge Line Thermostat in SRK-12H3			
LOW WATER PROTECTION	Float Switch			
ACCESSORIES -SUPPLIED	N/A			
-REQUIRED	Dispenser Unit or Ice Storage Bin SRK-12H3 Remote Condensing Unit			
OPERATING CONDITIONS	VOLTAGE RANGE (SRK-12H3)	187-253VAC		
	AMBIENT TEMP.	45-100°F		
	WATER SUPPLY TEMP.	45-90°F		
	WATER SUPPLY PRESSURE	10-113 PSIG		

Note: We reserve the right to make changes in specifications and design without prior notice.

3. SRK-12H

AC SUPPLY VOLTAGE	208-230/60/1 (115VAC Supplied to KMS via Factory Wire Harness)		
AMPERAGE	11.2 A (5 Min. Freeze AT 104°F / WT 80°F)		
MINIMUM CIRCUIT AMPACITY	20 A		
MAXIMUM FUSE SIZE	20 A		
EXTERIOR DIMENSIONS (WxDxH)	50" x 17" x 28" (1270 x 432 x 711 mm)		
DIMENSIONS INCLUDING LEGS (WxDxH)	52-3/8" x 19-1/2" x 43" (1330 x 495 x 1092 mm)		
EXTERIOR FINISH	Galvanized steel		
WEIGHT	Net 230 lbs. (104 kg) Shipping 273 lbs. (124 kg)		
CONNECTIONS - ELECTRIC	Main Power Supply: Permanent Connection SRK to KMS: Wire Harness Connection		
- REFRIGERANT	Suction line	1-1/8-12 UNF Fitting (# 11 Parker)	
	Liquid line	1-1/16-12 UNF Fitting (# 10 Parker)	
COMPRESSOR	Hermetic, Model CS12K6E-PFV-255		
CONDENSER	Air Cooled, Fin and Tube Type		
COMPRESSOR PROTECTION	Auto-Reset Overload Protector (Internal)		
FAN MOTOR PROTECTION	Thermal Protection		
REFRIGERANT CIRCUIT PROTECTION	Auto-Reset High-Pressure Switch Auto-Reset Discharge Line Thermostat		
REFRIGERANT CONTROL	Headmaster (C.P.R.) (160 PSI)		
REFRIGERANT CHARGE	16 lb. 5 oz. (7400g) (Condensing Unit 14 lb. 14 oz. (7200g)) (Icemaker 0 lb. 7 oz. (200g))		
DESIGN PRESSURE	High 467 PSIG, Low 230 PSIG		
OPERATING CONDITIONS	VOLTAGE RANGE	187 - 253VAC	
	AMBIENT TEMP. (Outdoor use)	-20 - 122°F	
ACCESSORIES -SUPPLIED	Leg		2 pcs
	Hex Head Bolt w/Washer	M8x16	8 pcs
	Hex Nut	M8	8 pcs
-REQUIRED	Compatible KMS Icemaker		

Note: We reserve the right to make changes in specifications and design without prior notice.

4. SRK-12H3

AC SUPPLY VOLTAGE	208-230/60/3 (115VAC Supplied to KMS via Factory Wire Harness)		
AMPERAGE	10.5 A (5 Min. Freeze AT 104°F/WT 80°F)		
MINIMUM CIRCUIT AMPACITY	20 A		
MAXIMUM FUSE SIZE	20 A		
EXTERIOR DIMENSIONS (WxDxH)	50"x17"x28" (1270x432x711 mm)		
DIMENSIONS INCLUDING LEGS (WxDxH)	52-3/8"x19-1/2"x43" (1330x495x1092 mm)		
EXTERIOR FINISH	Galvanized steel		
WEIGHT	Net 230 lbs. (104 kg)	Shipping 273 lbs. (124 kg)	
CONNECTIONS - ELECTRIC	Main Power Supply: Permanent Connection SRK to KMS: Wire Harness Connection		
- REFRIGERANT	Suction line	1-1/8-12 UNF Fitting (# 11 Parker)	
	Liquid line	1-1/16-12 UNF Fitting (# 10 Parker)	
COMPRESSOR	Hermetic, Model CS12K6E-TF5-255		
CONDENSER	Air Cooled, Fin and Tube Type		
COMPRESSOR PROTECTION	Auto-Reset Overload Protector (Internal)		
FAN MOTOR PROTECTION	Thermal Protection		
REFRIGERANT CIRCUIT PROTECTION	Auto-Reset High-Pressure Switch Auto-Reset Discharge Line Thermostat		
REFRIGERANT CONTROL	Headmaster (C.P.R.) (160 PSI)		
REFRIGERANT CHARGE	16 lb. 5 oz. (7400g) (Condensing Unit 14 lb. 14 oz. (7200g)) (Icemaker 0 lb. 7 oz. (200g))		
DESIGN PRESSURE	High 467 PSIG, Low 230 PSIG		
OPERATING CONDITIONS	VOLTAGE RANGE	187 - 253VAC	
	AMBIENT TEMP. (Outdoor use)	-20 - 122°F	
ACCESSORIES -SUPPLIED	Leg		2 pcs
	Hex Head Bolt w/Washer	M8x16	8 pcs
	Hex Nut	M8	8 pcs
-REQUIRED	Compatible KMS Icemaker		

Note: We reserve the right to make changes in specifications and design without prior notice.

B. Performance Data

1. KMS-1122MLH with SRK-12H

APPROXIMATE ICE PRODUCTION PER 24 HR.	AMBIENT TEMP. (°F/°C)	WATER TEMP. (°F/°C)					
		50/10		70/21		90/32	
	70/21	1100	<u>499</u>	1066	<u>484</u>	999	<u>453</u>
	80/27	1074	<u>487</u>	1022	<u>464</u>	943	<u>428</u>
	90/32	1066	<u>484</u>	985	<u>447</u>	910	<u>413</u>
lbs./day kg./day	100/38	1046	<u>474</u>	967	<u>439</u>	841	<u>381</u>
APPROXIMATE ELECTRIC CONSUMPTION	70/21	1830		1853		1884	
	80/27	1848		1884		1915	
	90/32	1853		1910		1941	
watts	100/38	1859		1917		1970	
APPROXIMATE WATER CONSUMPTION PER 24 HR.	70/21	473	<u>1.79</u>	391	<u>1.48</u>	352	<u>1.33</u>
	80/27	410	<u>1.55</u>	282	<u>1.07</u>	285	<u>1.08</u>
	90/32	391	<u>1.48</u>	192	<u>0.73</u>	176	<u>0.67</u>
gal./day m3/day	100/38	298	<u>1.13</u>	188	<u>0.71</u>	161	<u>0.61</u>
FREEZING CYCLE TIME	70/21	19		20		22	
	80/27	20		22		24	
	90/32	20		23		25	
min.	100/38	21		23		27	
HARVEST CYCLE TIME	70/21	3.5		3.1		3.0	
	80/27	3.2		2.5		2.7	
	90/32	3.1		2.1		2.1	
min.	100/38	2.7		2.1		2.1	
HEAD PRESSURE	70/21	178	<u>12.5</u>	193	<u>13.6</u>	216	<u>15.2</u>
	80/27	190	<u>13.3</u>	213	<u>15.0</u>	237	<u>16.6</u>
	90/32	193	<u>13.6</u>	230	<u>16.2</u>	253	<u>17.8</u>
PSIG kg/cm2G	100/38	198	<u>13.9</u>	235	<u>16.6</u>	275	<u>19.3</u>
SUCTION PRESSURE	70/21	42	<u>3.0</u>	43	<u>3.1</u>	49	<u>3.4</u>
	80/27	43	<u>3.0</u>	45	<u>3.2</u>	53	<u>3.7</u>
	90/32	43	<u>3.1</u>	47	<u>3.3</u>	54	<u>3.8</u>
PSIG kg/cm2G	100/38	46	<u>3.2</u>	49	<u>3.4</u>	60	<u>4.2</u>
TOTAL HEAT OF REJECTION FROM CONDENSER		21,300 BTU/h [AT 90°F (32°C) / WT 70°F (21°C)]					
CONDENSER VOLUME		226 CU. IN (SRK-12H)					

Note:

1. Pressure data is recorded at 5 min. into freezing cycle. The data not in bold should be used for reference only.
2. We reserve the right to make changes in specifications and design without prior notice.

2. KMS-1122MLH with SRK-12H3

APPROXIMATE ICE PRODUCTION PER 24 HR.	AMBIENT TEMP. (°F/°C)	WATER TEMP. (°F/°C)					
		50/10		70/21		90/32	
	70/21	1120	<u>508</u>	1085	<u>492</u>	1016	<u>461</u>
	80/27	1093	<u>496</u>	1039	<u>471</u>	958	<u>435</u>
	90/32	1085	<u>492</u>	1000	<u>454</u>	923	<u>419</u>
lbs./day <u>kg./day</u>	100/38	1064	<u>483</u>	982	<u>445</u>	852	<u>386</u>
APPROXIMATE ELECTRIC CONSUMPTION	70/21	1790		1828		1864	
	80/27	1819		1878		1905	
	90/32	1828		1920		1951	
watts	100/38	1830		1927		1980	
APPROXIMATE WATER CONSUMPTION PER 24 HR.	70/21	451	<u>1.71</u>	376	<u>1.42</u>	342	<u>1.29</u>
	80/27	394	<u>1.49</u>	277	<u>1.05</u>	281	<u>1.06</u>
	90/32	376	<u>1.42</u>	195	<u>0.74</u>	182	<u>0.69</u>
gal./day <u>m³/day</u>	100/38	292	<u>1.11</u>	192	<u>0.73</u>	170	<u>0.64</u>
FREEZING CYCLE TIME	70/21	19		20		22	
	80/27	20		22		24	
	90/32	20		23		25	
min.	100/38	21		23		27	
HARVEST CYCLE TIME	70/21	3.5		3.1		3.0	
	80/27	3.2		2.5		2.7	
	90/32	3.1		2.1		2.1	
min.	100/38	2.7		2.1		2.1	
HEAD PRESSURE	70/21	170	<u>12.0</u>	188	<u>13.3</u>	212	<u>14.9</u>
	80/27	184	<u>12.9</u>	213	<u>15.0</u>	235	<u>16.5</u>
	90/32	188	<u>13.3</u>	233	<u>16.4</u>	256	<u>18.0</u>
PSIG <u>kg/cm²G</u>	100/38	192	<u>13.5</u>	238	<u>16.8</u>	277	<u>19.5</u>
SUCTION PRESSURE	70/21	40	<u>2.8</u>	42	<u>3.0</u>	47	<u>3.3</u>
	80/27	42	<u>2.9</u>	45	<u>3.1</u>	51	<u>3.6</u>
	90/32	42	<u>3.0</u>	47	<u>3.3</u>	53	<u>3.7</u>
PSIG <u>kg/cm²G</u>	100/38	44	<u>3.1</u>	48	<u>3.4</u>	59	<u>4.1</u>

TOTAL HEAT OF REJECTION FROM CONDENSER 21,000 BTU/h [AT 90°F (32°C) / WT 70°F (21°C)]

CONDENSER VOLUME 226 CU. IN (SRK-12H3)

Note:

1. Pressure data is recorded at 5 min. into freezing cycle. The data not in bold should be used for reference only.
2. We reserve the right to make changes in specifications and design without prior notice.

C. Wiring Diagrams

1. Wire Harness Connections

Wire Harness Connections

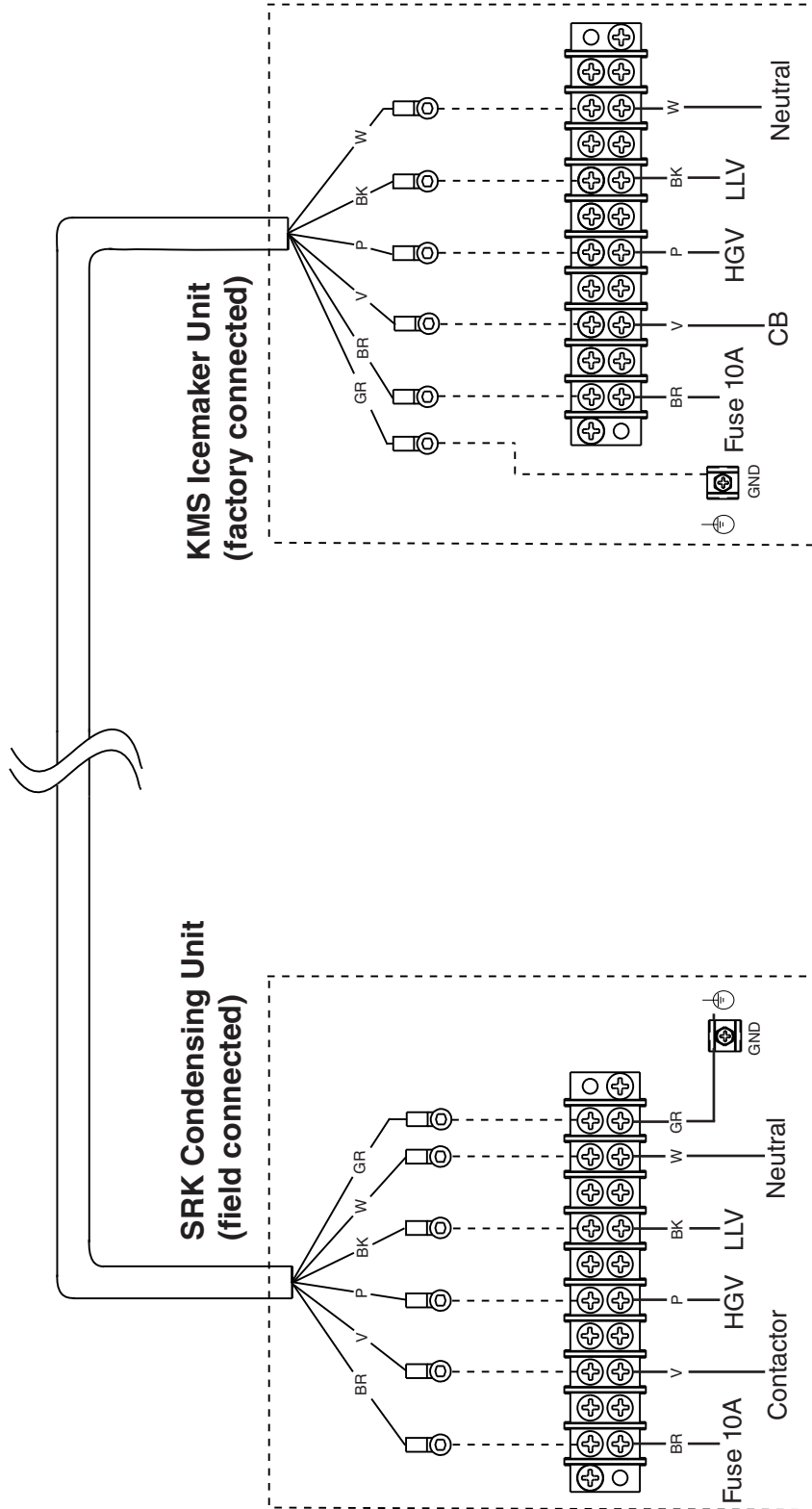

Legend:
 CB-control board
 GND-ground
 HGV-hot gas valve
 LLV-liquid line valve

Wire Color Code:
 BK-black
 BR-brown
 GR-green
 P-pink
 V-violet
 W-white

