



# HOSHIZAKI

## Service Manual

Modular Crescent Cuber

Models

KM-130ISAJ-E



[hoshizakiamerica.com](http://hoshizakiamerica.com)

Number: 73233  
Issued: 9-28-2018

## WARNING

Only qualified service technicians should install and service the icemaker. To obtain the name and phone number of your local Hoshizaki Certified Service Representative, visit [www.hoshizaki-europe.com](http://www.hoshizaki-europe.com). No service should be undertaken until the technician has thoroughly read this Service Manual. Failure to service and maintain the icemaker in accordance with this manual will adversely affect safety, performance, component life, and warranty coverage and may result in costly water damage. Proper installation is the responsibility of the installer. Product failure or property damage due to improper installation is not covered under warranty.

Hoshizaki provides this manual primarily to assist qualified service technicians in the service and maintenance of the icemaker. Should the reader have any questions or concerns which have not been satisfactorily addressed, please call the appropriate Hoshizaki Service Office:

UK/Ireland - Hoshizaki UK  
TEL : +44 (0)845 456 0585  
FAX: +44 (0)132 283 8331

Holland - Hoshizaki Europe  
TEL : +31 (0)20 6918499  
FAX: +31 (0)20 6918768

Belgium/Luxemburg - Hoshizaki Belgium  
TEL : +32 (0)2 7123030  
FAX: +32 (0)2 7123031

Germany/Switzerland/Austria - Hoshizaki Deutschland  
TEL : +49 (0)2154 92810  
FAX: +49 (0)2154 928128

France - Hoshizaki France  
TEL : +33 (0)1 48639380  
FAX: +33 (0)1 48639388

Other countries - Hoshizaki Europe  
TEL: +31 (0)20 6918499  
FAX: +31 (0)20 6918768

Web Site: [www.hoshizaki-europe.com](http://www.hoshizaki-europe.com)

**NOTE:** To expedite assistance, all correspondence/communication **MUST** include the following information:

- Model Number \_\_\_\_\_
- Serial Number \_\_\_\_\_
- Complete and detailed explanation of the problem.

## **IMPORTANT**

This manual should be read carefully before the appliance is serviced. Read the warnings and guidelines contained in this manual carefully as they provide essential information for the continued safe use, service, and maintenance of the appliance. Retain this manual for any further reference that may be necessary.

## **CONTENTS**

Important Safety Information .....	5
I. Construction and Water/Refrigeration Circuit Diagram .....	7
A. KM Construction.....	7
B. Bin Control .....	8
1. Single Bin Control .....	8
2. Stacked Bin Control.....	8
C. Water/Refrigeration Circuit Diagram.....	9
II. Sequence of Operation and Service Diagnosis .....	10
A. Sequence of Operation Flow Chart.....	10
1. Operation Flow Chart .....	10
2. Shutdown Flow Chart .....	11
B. Service Diagnosis .....	12
C. Control Board Check.....	18
D. Bin Control Check .....	19
1. Bin Control Check .....	19
2. Bin Control Cleaning.....	20
E. Float Switch Check and Cleaning .....	21
1. Float Switch Check .....	21
2. Float Switch Cleaning.....	22
F. Thermistor Check.....	23
G. Control Switch.....	23
H. Diagnostic Tables .....	24
I. Freeze-Up Check List .....	28
III. Controls and Adjustments .....	29
A. Control Board Layout .....	30
B. LED Lights and Audible Alarm Safeties.....	31
C. Settings and Adjustments.....	32
1. Default Dip Switch Settings .....	32
2. Harvest Time (S4 dip switch 1 & 2).....	33
3. Pump-Out Time/Harvest Time During Pump-Out (S4 dip switch 3 & 4).....	33
4. Pump-Out Frequency Control (S4 dip switch 5).....	34
5. Harvest Pump Time (Harvest Assist) (S4 dip switch 6) .....	34
6. Harvest Pump Time (Harvest Assist) (S4 dip switch 7) .....	35
7. Factory Use (S4 dip switch 8).....	35
8. Freeze Timer (S4 dip switch 9 & 10) .....	36
9. Float Switch Control Selector (S5 dip switch 1) .....	36
10. Refill Counter (S5 dip switch 2 and 3).....	37

IV. Refrigeration Circuit and Component Service Information.....	38
A. Refrigeration Circuit Service Information .....	38
B. Component Service Information.....	41
V. Maintenance .....	42
VI. Preparing the Icemaker for Periods of Non-Use .....	43
VII. Disposal.....	44
VIII. Technical Information.....	45
A. Specification and Performance Data .....	45
B. Wiring Diagram.....	46

---

## Important Safety Information

Throughout this manual, notices appear to bring your attention to situations which could result in death, serious injury, damage to the appliance, or damage to property.

**⚠ WARNING** Indicates a hazardous situation which could result in death or serious injury.

**NOTICE** Indicates a situation which could result in damage to the appliance or property.

**IMPORTANT** Indicates important information about the use and care of the appliance.

### **⚠ WARNING**

The appliance should be destined only to the use for which it has been expressly conceived. Any other use should be considered improper and therefore dangerous. The manufacturer cannot be held responsible for injury or damage resulting from improper, incorrect, and unreasonable use. Failure to service and maintain the appliance in accordance with this manual will adversely affect safety, performance, component life, and warranty coverage and may result in costly water damage.

**To reduce the risk of death, electric shock, serious injury, or fire, follow basic precautions including the following:**

- Only qualified service technicians should install and service this appliance.
- The appliance must be installed in accordance with applicable national, state, and local codes and regulations. Failure to meet these code requirements could result in death, electric shock, serious injury, fire, or damage to the appliance.
- Electrical connection must be hard-wired and must meet national, state, and local electrical code requirements. Failure to meet these code requirements could result in death, electric shock, serious injury, fire, or damage.
- The icemaker requires an independent power supply of proper capacity. See the nameplate for electrical specifications. Failure to use an independent power supply of proper capacity can result in a tripped breaker, blown fuse, damage to existing wiring, or component failure. This could lead to heat generation or fire.
- **THE ICEMAKER MUST BE EARTHED (GROUNDED). 220-240VAC UK and the Republic of Ireland:** Failure to properly ground the icemaker could result in death or serious injury.
- To reduce the risk of electric shock, do not touch the control switch with damp hands.
- Move the control switch to the "OFF" position and turn off the power supply before servicing. Lockout/Tagout to prevent the power supply from being turned back on inadvertently.
- Do not make any alterations to the appliance. Alterations could result in electric shock, serious injury, fire, or damage.

**⚠ WARNING, continued**

- The appliance is not intended for use by persons (including children) with reduced physical, sensory, or mental capabilities, or lack of experience and knowledge, unless they have been given supervision or instruction concerning use of the appliance by a person responsible for their safety.
- Children should be properly supervised around the appliance.
- Do not climb, stand, or hang on the appliance or allow children or animals to do so. Serious injury could occur or the appliance could be damaged.
- Do not use combustible spray or place volatile or flammable substances near the appliance. They might catch fire.
- Keep the area around the appliance clean. Dirt, dust, or insects in the appliance could cause harm to individuals or damage to the appliance.

***NOTICE***

- Follow the instructions in this manual carefully to reduce the risk of costly water damage.
- In areas where water damage is a concern, install in a contained area with a floor drain.
- Install the appliance in a location that stays above freezing. Normal operating ambient temperature must be within 45°F to 100°F (7°C to 38°C).
- Do not leave the appliance on during extended periods of non-use, extended absences, or in sub-freezing temperatures. To properly prepare the appliance for these occasions, follow the instructions in "VI. Preparing the Icemaker for Periods of Non-Use."
- Do not place objects on top of the appliance.
- The dispenser unit/ice storage bin is for ice use only. Do not store anything else in the dispenser unit/ice storage bin.

# I. Construction and Water/Refrigeration Circuit Diagram

## A. KM Construction

### 1. Air-Cooled Model

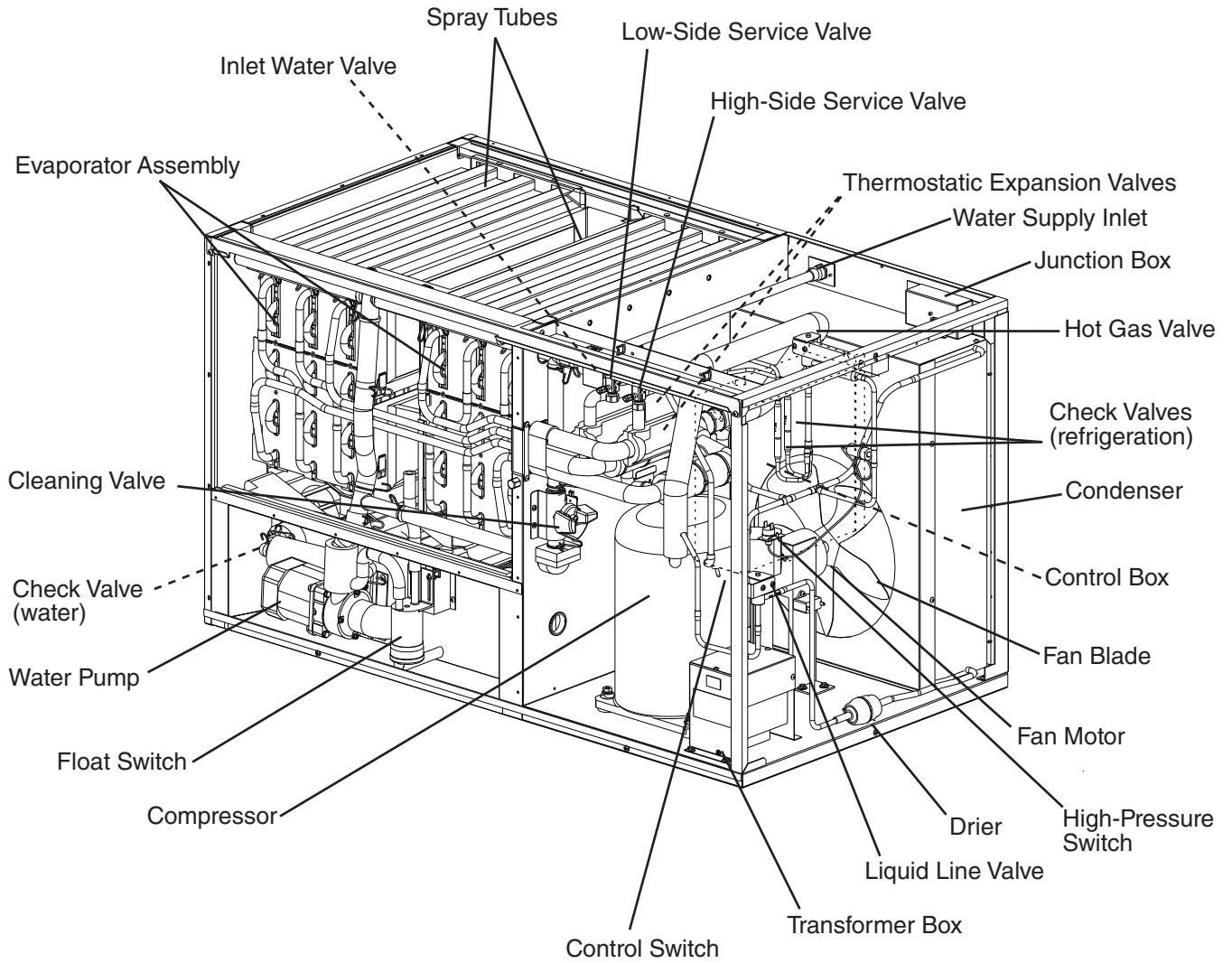

## B. Bin Control

### 1. Single Bin Control

#### Mechanical Bin Control Connection Overview

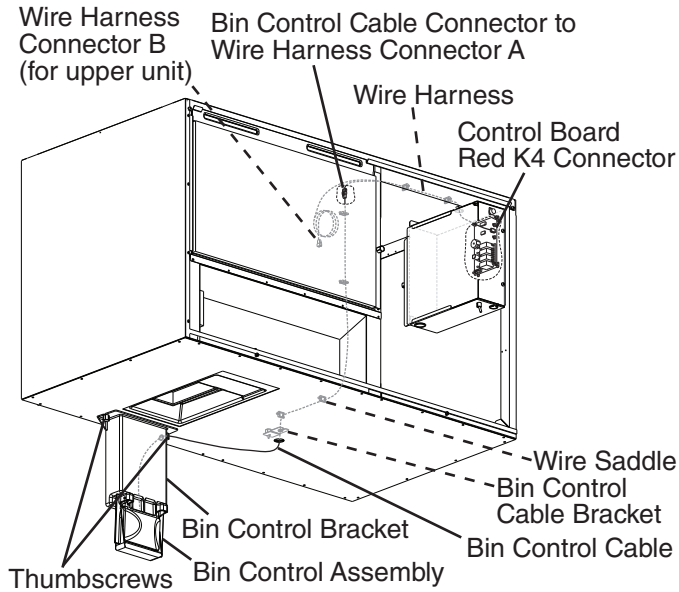

#### Connection Detail

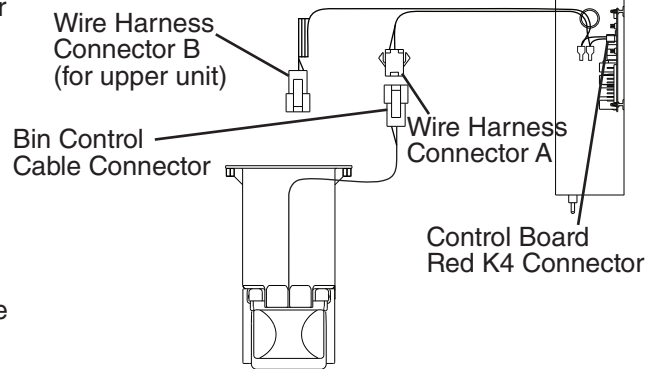

### 2. Stacked Bin Control

#### Upper Unit Connection Overview

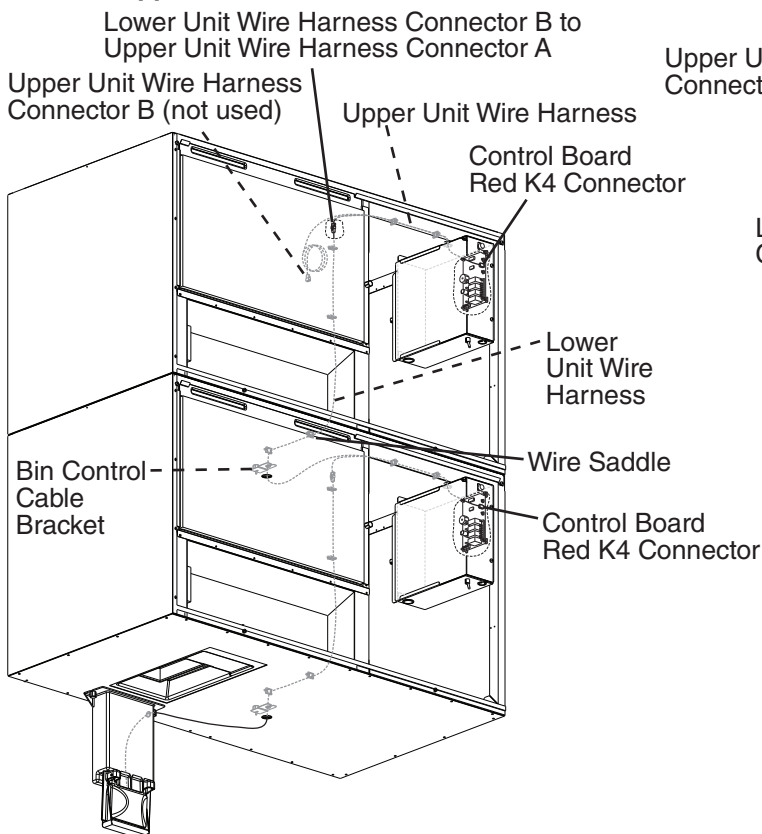

#### Upper Unit Connection Detail

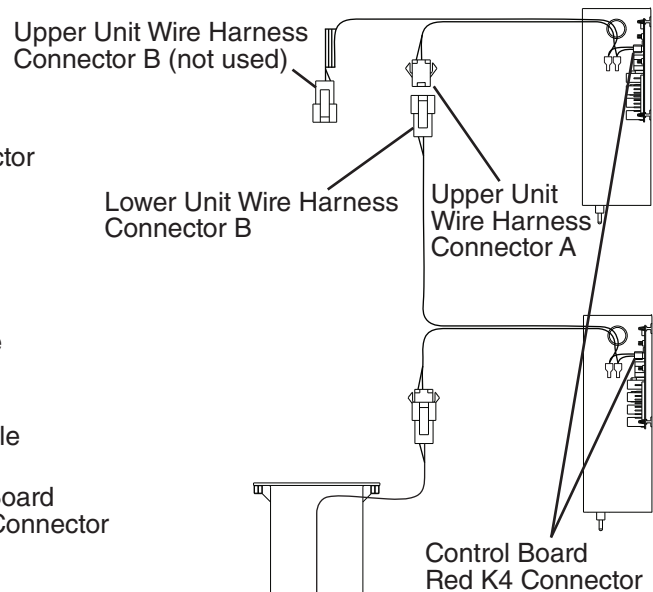

# C. Water/Refrigeration Circuit Diagram

## 1. Air-Cooled Model

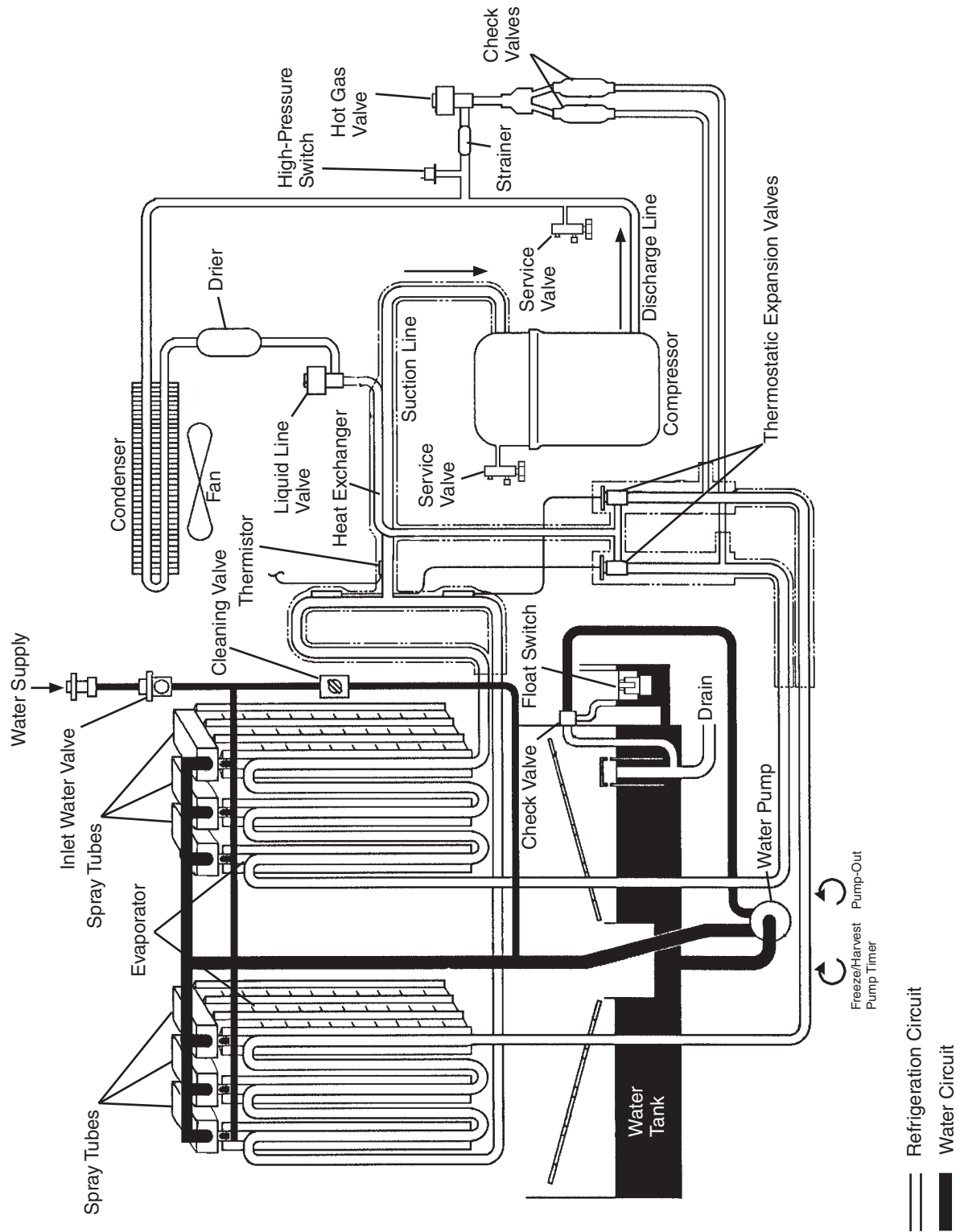

## II. Sequence of Operation and Service Diagnosis

### A. Sequence of Operation Flow Chart

#### 1. Operation Flow Chart

Operation Flow Chart

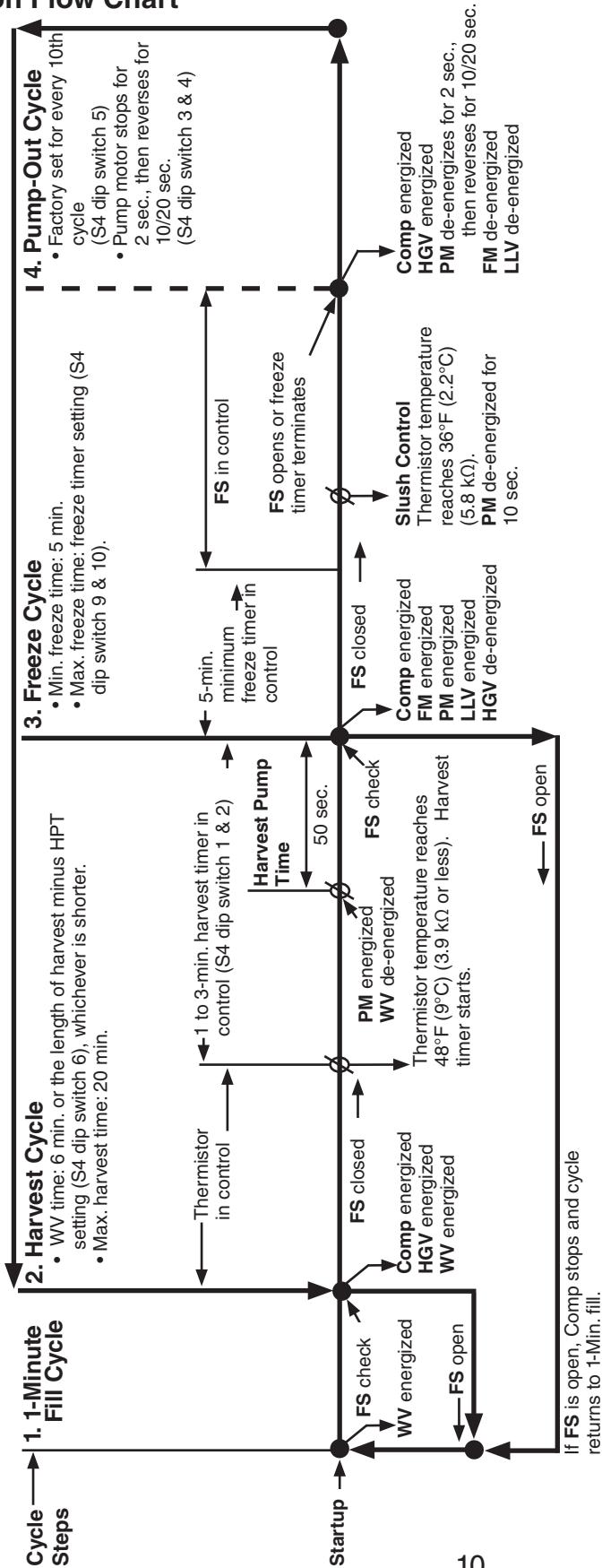

10

**Legend:**

- BC—bin control
- CB—control board
- Comp—compressor
- FM—fan motor
- FS—float switch
- HGV—hot gas valve
- HPT—harvest pump time
- LLV—liquid line valve
- PM—pump motor
- WV—inlet water valve

**Components Energized when the Control Switch is in the "WASH" Position**

The "WASH" position on the control switch is used when cleaning and sanitizing the unit. When in the "WASH" position, power is supplied to the pump motor. With the cleaning valve closed, the cleaner and sanitizer flow over the outside of the evaporator plate assembly. With the cleaning valve open, the cleaner and sanitizer flow over both the outside and the inside of the evaporator plate assembly.  
 Note: Close the cleaning valve after cleaning and sanitizing are complete, otherwise the unit will not restart when the control switch is placed in the "ICE" position.

## 2. Shutdown Flow Chart

### Shutdown Flow Chart

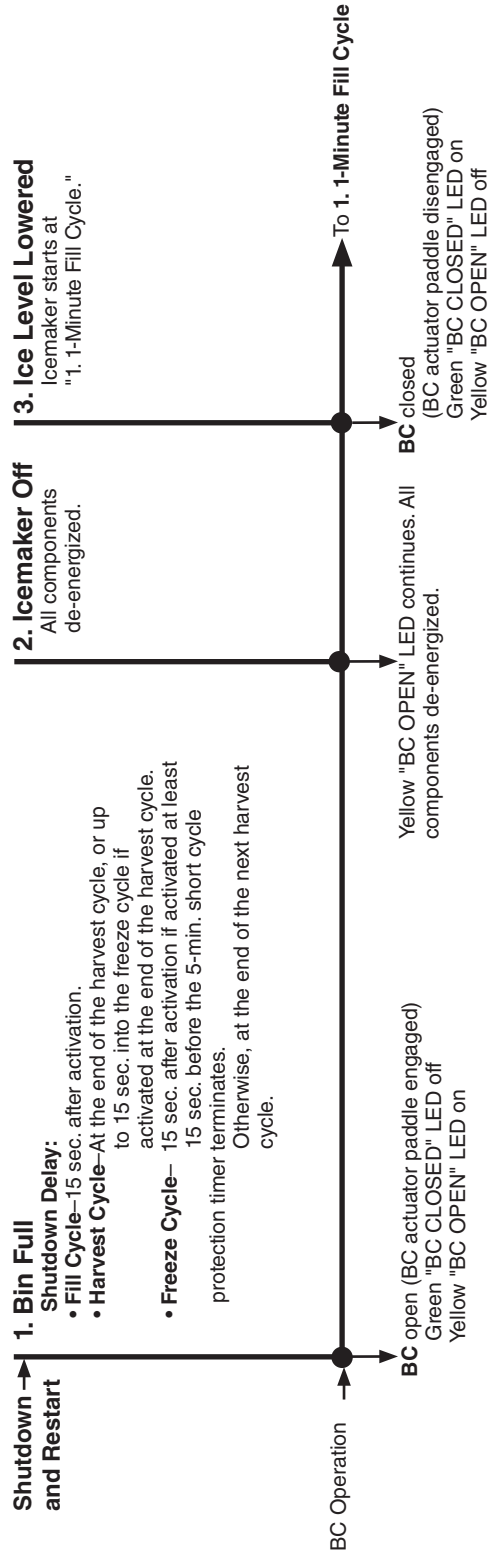

**Legend:**  
BC—bin control

## B. Service Diagnosis

### WARNING

- The appliance should be diagnosed and repaired only by qualified service personnel to reduce the risk of death, electric shock, serious injury, or fire.
- Risk of electric shock. Control switch in "OFF" position does not de-energize all loads Use extreme caution and exercise safe electrical practices.
- Moving parts (e.g., fan blade) can crush and cut. Keep hands clear.
- Before servicing the appliance, move the control switch to the "OFF" position and turn off the power supply.
- **CHOKING HAZARD:** Ensure all components, fasteners, and thumbscrews are securely in place after the appliance is serviced. Make sure that none have fallen into the dispenser unit/ice storage bin.
- Make sure all food zones in the appliance and dispenser unit/ice storage bin are clean after service.

The diagnostic procedure is a sequence check that allows you to diagnose the electrical system and components. Before proceeding, check for correct installation, proper voltage per nameplate, and adequate water supply. Check CB using the steps in "II.C. Control Board Check." Check dip switch settings to assure that S4 dip switch 3, 4, 7, 8, 9, 10 and S5 dip switch 1 through 5 are in the factory default position. S4 dip switch 1, 2, 5, 6 are cleaning adjustments and the settings are flexible. For factory default settings, see "III.C.1. Default Dip Switch Settings."

Note: • When checking high voltage (115VAC), always choose a white (W) neutral wire to establish a good neutral connection.

- The 115VAC neutral (W) is provided through the MT. To confirm a good neutral, check for 60VAC from white (W) neutral to ground (GND). If 60VAC is present, neutral is good. If 60VAC is not present, check 230VAC main power supply to MT. If 230VAC is present, check MT continuity.
- When checking voltage from the CB K1 connector (10 pin connector), pull CB K1 connector out slightly to allow room for multimeter test leads contact.

- 1) Turn off the power supply, then access the control box. Move the control switch to the "OFF" position. Clear any ice from BC.
- 2) Check that BC is closed and the 115VAC 10A fuse is good.

## 1. Operation Diagnosis

- 3) **Power On:** Turn on the power supply, then move the control switch to the "ICE" position. A 5-sec. delay occurs. CB red "POWER OK" LED and green "BC CLOSED" LED turn on. If yellow "BC OPEN" LED is on (indicating a full bin), check BC. Move ice away from BC actuator paddle. If yellow "BC OPEN" LED stays on, see "II.D. Bin Control Check."

Note: • CB red "POWER OK" LED remains on unless the 10.5VAC power supply is interrupted (K2 connector).

- Check CB using the steps in "II.C.Control Board Check."
- Confirm CB green "BC CLOSED" LED is on. If CB yellow "BC OPEN" LED is on, remove ice from BC. If no ice is around BC and yellow "BC OPEN" LED is on, see "II.D. Bin Control Check."

- a) **Power On Diagnosis:** If CB red "POWER OK" LED is off, confirm 10A fuse is good. Check for 115VAC at control switch #1 (LBU) to neutral (W) then at control switch #2 (P) to neutral (W). If 115VAC is present on #1 (LBU) and not on #2 (P), replace control switch. If 115VAC is present on control switch #2 (P), check for 115VAC at HPS (P) to neutral (W) then HPS (BK) to neutral (W). If 115VAC is present at HPS (P) and not at HPS (BK), HPS is open. See HPS Diagnosis below. If 115VAC is present at HPS (BK), check for 10.5VAC at CB K2 #1 red wire to CB K2 #2 red wire. If 10.5VAC is not present, check that the cleaning valve interlock switch is closed. Next, check CT continuity. If open, replace CT.

- b) **HPS Diagnosis:** Confirm condenser coil is not clogged or restricted. Let refrigeration circuit pressures equalize. If HPS does not reset and pressures are equalized, replace HPS. If pressures are not equalized, reclaim refrigerant and diagnose refrigeration circuit restriction. Check that there are no restrictions in the refrigeration circuit.

Harvest Cycle: HGV, strainer, or check valve.

Freeze Cycle: FM, TXV, LLV, strainer, check valve, drier, and fan blade for binding.

Confirm that the location meets installation requirements. See the appliance's instruction manual for details.

- 4) **1-Min. Fill Cycle – LED 4 is on.** WV and X11 relay energize. After 1 min., CB checks for a closed FS. If FS is closed, the harvest cycle begins. If harvest cycle begins (Comp, HGV, FMR energized), continue to step 5a. If FS is open, WV remains energized until FS closes (low water safety protection during initial start up and at the end of each harvest). **Diagnosis:** Check that water enters the water tank. If not, check that the water supply line shut-off valve is open and screens or external filters are clear. Check for 115VAC at CB K1 #6 (O) to neutral (W). If 115VAC is not present, replace CB. If 115VAC is present, and WV does not energize, check for 115VAC at WV. If 115VAC is present, check coil continuity. If open, replace WV. If the water tank fills, but the appliance fails to start harvest (Comp energized), check for open FS. See "II.E. Float Switch Check and Cleaning." If FS is closed and CB fails to start the harvest cycle after 1 min., replace CB.

5a) **Initial Harvest Cycle – LEDs 1, 4, and 2 are on.** WV and X11 relay continue. Comp, FMR, HGV, and X10 relay energize. CB monitors the warming of the evaporator via the thermistor located on the suction line. When the thermistor reaches 48°F (9°C), CB reads 3.9 kΩ from the thermistor and turns harvest termination over to the harvest timer (S4 dip switch 1 & 2 and S5 dip switch 4). WV and X11 relay are energized during harvest for a maximum of 6 min. or the length of harvest minus HPT setting (S4 dip switch 6), whichever is shorter. See step 5b below.

- a) **Comp Diagnosis:** Check that evaporator is warming. If not, confirm that Comp energizes. If not, check for 115VAC at CB K1 #1 (V) or #9 (V) to neutral (W). If 115VAC is not present, check for 115VAC at CB K1 #7 (LBU) or #10 (LBU) to neutral (W). If 115VAC is present at #7 (LBU) or #10 (LBU) and not at #1 (V) or #9 (V), replace CB. If 115VAC is present, check for 115VAC at CR solenoid. If 115VAC is present, confirm contacts are closed. If not, replace CR. If CR contacts are closed, check Comp start and run capacitors, Comp start relay, and Comp motor winding.
- b) **HGV Diagnosis:** If Comp is energized and evaporator is not warming, check that HGV energizes and opens. Check for 115VAC at CB K1 #2 (P) to neutral (W). If 115VAC is not present and LED 2 is on, replace CB. If 115VAC is present, check for 115VAC at HGV coil and check HGV coil continuity. Replace as needed.
- c) **LLV Diagnosis:** Confirm that LLV is de-energized and closed (not bypassing). If energized, replace CB. If de-energized and bypassing, replace LLV.

5b) **Harvest Pump Time (Harvest Assist) – LEDs 1, 3, and 2 are on.** When the thermistor reaches 48°F (9°C), CB reads 3.9 kΩ from the thermistor and turns harvest termination over to the harvest timer (S4 dip switch 1 & 2 and S5 dip switch 4). When WV de-energizes, LED 4 turns off, X11 relay de-energizes and LED 3 turns on. PM energizes. Comp, HGV, and X10 relay continue.

**Diagnosis:** Place a thermometer on the suction line next to the thermistor. Has it warmed to 48°F (9°C) or warmer? Confirm thermistor status. See "II.F. Thermistor Check." If the thermistor reading is in proper range, dip switch 7 is on, and PM does not energize before harvest terminates, replace CB. If WV continues, check for 115VAC at CB K1 #6 (O). If 115VAC is present, and LED 4 is off, replace CB. If LED 3 is on and PM is not energized, check for 115VAC at CB K1 #5 (DBU). If 115VAC is not present, replace CB. If 115VAC is present and PM is not energized, check for 115VAC at X10 relay terminal #7 (Y) to neutral (W). If 115VAC is not present, check for 115VAC at X10 relay terminal #3 (P) to neutral (W) and X10 relay terminal #5 (Y) to neutral (W). If 115VAC is present on terminal #3 (P) and not on terminal #5 (Y), replace X10 relay. If 115VAC is present on X10 relay terminal #7 (Y) and PM is not energized, check for 115VAC at X10 relay terminal #4 (R) to neutral (W) and terminal #6 (DBU) to neutral (W). If 115VAC is present on terminal #6 (DBU) and not on terminal #4 (R), replace X10 relay. If 115VAC is present on X10 relay terminal #4 (R), check control switch contact continuity between terminals #4 (R) and #5 (R). If contacts are open, replace control switch. If contacts are closed and 115VAC is present between control switch terminal #5 (R) and neutral (W), check PM capacitor and motor winding continuity.

5c) **Initial Harvest Cycle Termination Diagnosis:** When the thermistor reaches 48°F (9°C), CB reads 3.9 kΩ from the thermistor and turns harvest termination over to the harvest timer (S4 dip switch 1 & 2 and S5 dip switch 4). Check discharge line temperature. For a thermistor check, see "II.F. Thermistor Check." If 1-min. fill cycle starts after harvest timer terminates, check that FS is clean and operating properly, see "II.E. Float Switch Check and Cleaning." If FS is closed, CB proceeds to the next cycle. If not, replace CB.

Note: The minimum total time allowed by CB for a complete harvest cycle is based on S5 dip switch 4. Maximum harvest time allowed is 20 min.

**NOTICE! S4 dip switch 7 must remain on. Otherwise, PM will not energize during the last seconds of harvest.**

6) **Freeze Cycle – LED 1 is on.** Comp and PM continue. FM and LLV energize. HGV and X10 relay de-energize. Appliance is held in freeze by a 5-min. short cycle protection timer. After 5-min. short cycle protection timer terminates and FS opens, freeze cycle terminates.

Note: PM power supply switches from CB K1 #5 (DBU) in harvest to K1 #4 (R) in freeze.

**Slush Control:** When slush control is enabled (S5 dip switch 5 "ON"), PM de-energizes when thermistor reaches 36°F (2.2°C) (5.8kΩ) for 10 sec. then, energizes for the remainder of the freeze cycle.

a) **Freeze Cycle Diagnosis:** Confirm Comp and PM continue. Confirm that FM and LLV energize. Confirm HGV and X10 relay de-energize. During the first 5 min. of freeze, confirm evaporator is cooling. If not, confirm WV de-energized (not leaking by), HGV de-energized (not bypassing), LLV and FM energize, TXV operates correctly, Comp is efficient, and refrigerant charge is correct. See "VIII.A. Specification and Performance Data."

b) **Comp Diagnosis:** If Comp de-energizes once freeze begins, check that appliance has not shut off on HPS ("POWER OK" LED off). If so, check "3)b) HPS Diagnosis" above. If "POWER OK" LED is on, check for 115VAC at CB K1 #1 (V) or #9 (V) to neutral (W). If 115VAC is not present and LED 1 is on, replace CB.

**Comp:** If 115VAC is present, check for 115VAC at CR coil. If 115VAC is present, check CR coil and contact continuity. Replace as needed. If CR is okay, check Comp start relay and start and run capacitors. Next, check Comp motor winding continuity. If Comp is energized but evaporator is not cooling, check for an inefficient Comp. See "VIII.A. Specification and Performance Data."

c) **WV and HGV Diagnosis:** If WV is energized, check for 115VAC at CB K1 #6 (O) to neutral (W). If 115VAC is present after PM energizes in harvest cycle, replace CB. If 115VAC is not present, replace WV (bypassing). If HGV did not close at the end of harvest, check for 115VAC at CB K1 #2 (P) to neutral (W). If 115VAC is present and LED 3 is off, replace CB. If 115VAC is not present, replace HGV (bypassing).

d) **PM Diagnosis:** Confirm water is flowing over evaporator from PM and not WV. If PM de-energizes once freeze begins, check for 115VAC at CB K1 #4 (R) to neutral (W). If 115VAC is not present, replace CB. If 115VAC is present and PM is de-energized, check for 115VAC at control switch #5 (R) to neutral (W). If 115VAC is present at CB K1 #4 (R) and not at control switch #5 (R), check control switch continuity between #5 (R) and #4 (R). Replace as needed. If 115VAC is present at control switch #5 (R) to neutral (W), check PM capacitor and motor winding continuity.

e) **FM and LLV Diagnosis:** If FM or LLV does not energize, check for 115VAC at CB K1 #3 (BK) to neutral (W). If 115VAC is not present, replace CB. If 115VAC is present: For FM, check capacitor, motor winding, and blade for binding. For LLV, check coil voltage and continuity.

f) **Refrigerant Pressures and TXV Diagnosis:** If evaporator is still not cooling, check refrigerant pressures. See "VIII.A. Specification and Performance Data." Next, check TXV for proper operation. Remove TXV bulb and hold it in your hand, refrigerant low-side pressure should rise, place TXV bulb in ice water, refrigerant low-side pressure should drop. A 10 to 15 pound pressure swing between warm and cold conditions indicate a good TXV. If a 10 to 15 pound swing is not present, replace TXV.

g) **Freeze Termination Diagnosis:** After 5 min. in freeze, disconnect CB K5 FS connector. 15 sec. later appliance should switch out of the freeze cycle (15 second delay after FS opens before terminating the freeze cycle). If appliance remains in freeze longer than 15 sec. after FS removed, replace CB. If appliance switches with FS removed but would previously not switch out of freeze with FS connected (long freeze - 3 beep alarm), see "II.E. Float Switch Check and Cleaning."

Note: Normal freeze cycle will last 20 to 40 min. depending on model and conditions. Cycle times and pressures should follow performance data provided in this manual. See "VIII.A. Specification and Performance Data."

h) **Short Freeze Cycle Diagnosis:** Confirm water tank fills and overflows during fill and harvest cycles. If not, check water supply filters, shut-off valve, WV screen. If water tank empties before 5 min. timer terminates and freeze cycle is short, check that CV is not leaking by (water flowing down the potable drain). If CV is leaking by, remove and clean CV, replace rubber seat and spring if necessary. If water tank is full, see "II.E. Float Switch Check and Cleaning." for erratic FS.

7) **Pump-Out Cycle – LEDs 1, 3, and 2 are on (10/20 second pump-out).** Timing of the first pump-out is determined by S4 dip switch 5. See the table below.

Control Board Settings		
S4 Dip Switch Setting	Pump-Out Frequency	1st Pump-Out
No. 5		
OFF	Every 10 cycles	After 11th freeze cycle
ON	Every cycle	After 2nd freeze cycle

Comp continues, HGV energizes. If S4 dip switch 3 & 4 are set to 3 off and 4 on, LED 4 turns on and WV and X11 relay energize, energizing X10 relay. **NOTICE! S4 dip switch 3 & 4 must not be set to 3 off and 4 on. Otherwise, PM will rotate in freeze cycle direction instead of pump-out direction.** FM and LLV de-energize. PM stops for 2 sec., then reverses for 10/20 sec. depending on pump-out timer (S4 dip switch 3 & 4) setting. When the pump-out timer terminates, pump-out is complete. The pump-out frequency control (S4 dip switch 5) is factory set, and generally no adjustment is required. However, the pump-out frequency control can be set to have a pump-out occur every 10 cycles or every cycle. For details, see "III.C.4. Pump-Out Frequency Control (S4 dip switch 5)."

**Pump-Out Diagnosis:** In the freeze cycle before pump-out (see table above), after 5 min. of freeze disconnect CB black K5 connector (FS connector). Check that PM stops and re-starts. Next, check that PM rotation is correct (water flowing down the drain through CV). If PM does not stop and re-start, check that CB LEDs 1, 3, and 2 are on. If not, replace CB. If LEDs 1, 3, and 2 are on and PM does not energize, check for 115VAC at CB K1 #5 (DBU) to neutral (W). If 115VAC is not present, replace CB. If 115VAC is present, check that X10 relay is de-energized. If not, check X11 relay status. If X11 relay is energized, replace CB. If X11 relay is de-energized and X10 relay is energized, replace X11 relay (contacts sticking). If X10 relay is de-energized, check for 115VAC at terminal #6 (DBU) to neutral (W) and terminal #2 (DBU) to neutral (W). If 115VAC is present on terminal #6 (DBU) and not on terminal #2 (DBU), replace X10 relay. If PM is energized and rotating in pump-out rotation, make sure the drain line is not clogged and that CV is clean and operating properly.

Confirm FM and LLV de-energize. If FM is energized, confirm where FM is connected on CB. If connected to CB K1 connector pin #9, FM should be energized. If connected to CB K1 connector pin #3 and FM is energized, replace CB. If LLV is energized with LEDs 1, 3, and 2 on, replace CB.

8) **Normal Harvest Cycle** – Same as the initial harvest cycle. Return to step 5a) above.

Note: Appliance continues to cycle until BC is satisfied, power is switched off or freeze-time correction cycle is initiated. The appliance always restarts at the 1-min. fill cycle.

## 2. Shutdown Diagnosis

1) See "I.I.D. Bin Control Check."

Legend: **BC**–bin control; **CB**–control board; **Comp**–compressor; **CR**–compressor relay; **CT**–control transformer; **CV**–check valve; **FM**–fan motor; **FS**–float switch; **HGV**–hot gas valve; **HPS**–high-pressure switch; **LLV**–liquid line valve; **PM**–pump motor; **TXV**–thermostatic expansion valve; **WV**–inlet water valve

## C. Control Board Check

Before replacing CB that does not show a visible defect and that you suspect is bad, always conduct the following check procedure. This procedure will help you verify your diagnosis.

Alarm Reset: If CB is in alarm (beeping), press the "ALARM RESET" button on CB while CB is beeping. **WARNING! Risk of electric shock. Care should be taken not to touch live terminals.** Once reset, the icemaker starts at the 1-minute fill cycle. For audible alarm information, see "III.B. LED Lights and Audible Alarm Safeties."

- 1) Check the dip switch settings to assure that S4 dip switch 3, 4, 7, 8, 9, 10 and S5 dip switch 1 through 5 are in the factory default position. S4 dip switch 1, 2, 5 are cleaning adjustments and the settings are flexible. For factory default settings, see "III.C.1. Default Dip Switch Settings."
- 2) Move the control switch to the "ICE" position. If the red "POWER OK" LED is on, control voltage is good, continue to step 3. If the "POWER OK" LED is off, check CT secondary circuit. CT output is 10.5VAC at 115VAC primary input. If the secondary circuit has proper voltage and the red LED is off, replace CB.

If the secondary circuit does not have proper voltage, check CT primary circuit. Check for 115VAC at CB K1 connector pin #10 (LBU) to neutral (W) for 115VAC. Always choose a white (W) neutral wire to establish a good neutral connection when checking voltages. For additional checks, see "II.H.1. No Ice Production."

- 3) The "OUTPUT TEST" button provides a relay sequence test. Make sure the control switch is in the "ICE" position, then press the "OUTPUT TEST" button. For the correct lighting sequence, see the table below. Note that the order of the LEDs from the outer edge of the control board is 1, 4, 3, 2. Components (e.g., compressor) cycle during the test.

Following the test, the icemaker begins operation at the 1-minute fill cycle. If the LEDs do not light as described above, replace CB.

- 4) To verify voltage output from CB to the components, slide the CB K1 connector out far enough to allow multimeter lead contact. With the icemaker in the cycle to be tested, check output voltage from the corresponding pin on CB K1 connector to a neutral (W wire). If output voltage is not found and the appropriate LED is on, replace CB.
- 5) Confirm BC communication and shutdown sequence: Move the control switch to the "ICE" position. Once the fill cycle starts press and hold the BC actuator paddle. CB shuts down the appliance after 15 sec. If not, confirm BC status. See "II.D. Bin Control Check." If BC checks ok, replace CB.

Legend: **CB**—control board; **CT**—control transformer

## D. Bin Control Check

### 1. Bin Control Check

This appliance uses a lever-actuated proximity switch to control the ice level in the storage bin. No adjustment is required.

To check BC, follow the steps below.

- 1) Turn off the power supply.
- 2) Remove the front panel, then move the control switch to the "OFF" position.
- 3) Remove the control box cover, then clear any ice away from BC.
- 4) Check BC wire harness connections. See Fig. 1.
- 5) Disconnect BC connector from CB K4 connector.
- 6) Check for continuity across the wires of BC connector. When the actuator paddle is not engaged, BC switch is closed. If open, check that the wire harness connector is properly connected and that the actuator paddle is not sticking. Clean if necessary. See "II.D. Bin Control Cleaning." If BC switch still reads open, replace BC.
- 7) Press and hold the actuator paddle; check for continuity across the wires of BC connector. When the actuator paddle is engaged, BC switch is open. If closed, check that the actuator paddle is not restricted. Clean if necessary. See "II.D. Bin Control Cleaning." If BC switch still reads closed, replace BC.
- 8) Reconnect BC connector to CB K4 connector, then move the control switch to the "ICE" position. Turn on the power supply.
- 9) Check that CB green "BC CLOSED" LED is on.
- 10) Allow the icemaker to cycle on. Press and hold the actuator paddle. CB yellow "BC OPEN" LED should turn on and the icemaker should shut down according to the chart below. If it does not, replace CB.

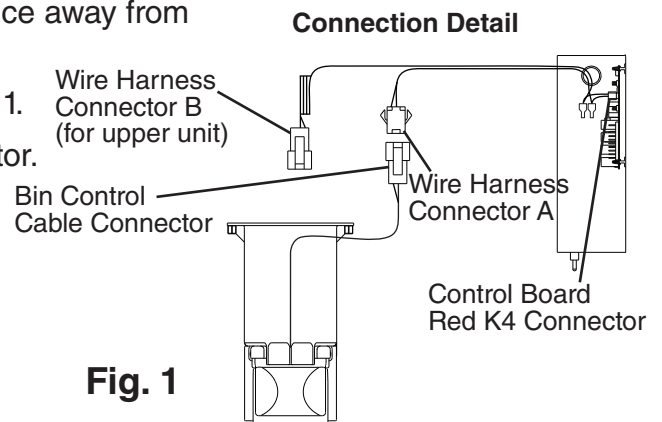

Cycle at Mechanical Bin Control Activation	Shutdown
Fill Cycle	15 sec. after activation.
Harvest Cycle	At the end of the harvest cycle, or up to 15 sec. into the freeze cycle if activated at the end of the harvest cycle.
Freeze Cycle	15 sec. after activation if activated at least 15 sec. before the 5-min. short cycle protection timer terminates. Otherwise, at the end of the next harvest cycle.

Legend: **BC**—bin control; **CB**—control board

## 2. Bin Control Cleaning

Scale may build up on BC. Scale can cause the actuator paddle and magnet to stick. In this case, BC should be cleaned.

### **⚠ WARNING**

**CHOKING HAZARD:** Ensure all components, fasteners, and thumbscrews are securely in place after the icemaker is serviced. Make sure that none have fallen into the dispense unit/ice storage bin.

- 1) Turn off the power supply.
- 2) Remove the front panel, then move the control switch to the "OFF" position.
- 3) Clear any ice away from BC.
- 4) Disconnect BC connector from CB K4 connector, then remove BC from the icemaker.
- 5) Remove the actuator paddle from the switch mount. See Fig. 2.
- 6) Wipe down BC with a mixture of 1 part of Hoshizaki "Scale Away" and 25 parts of warm water. Rinse the parts thoroughly with clean water.
- 7) Reassemble BC and replace it in its correct position.  
Note: If the magnet was removed for cleaning, be sure to replace it in its correct position.
- 8) Reconnect BC connector to CB K4 connector, then move the control switch to the "ICE" position.
- 9) Replace the control box cover in its correct position.
- 10) Turn on the power supply to start the automatic icemaking process.
- 11) Replace the front panel in its correct position.

Legend: **BC**—bin control

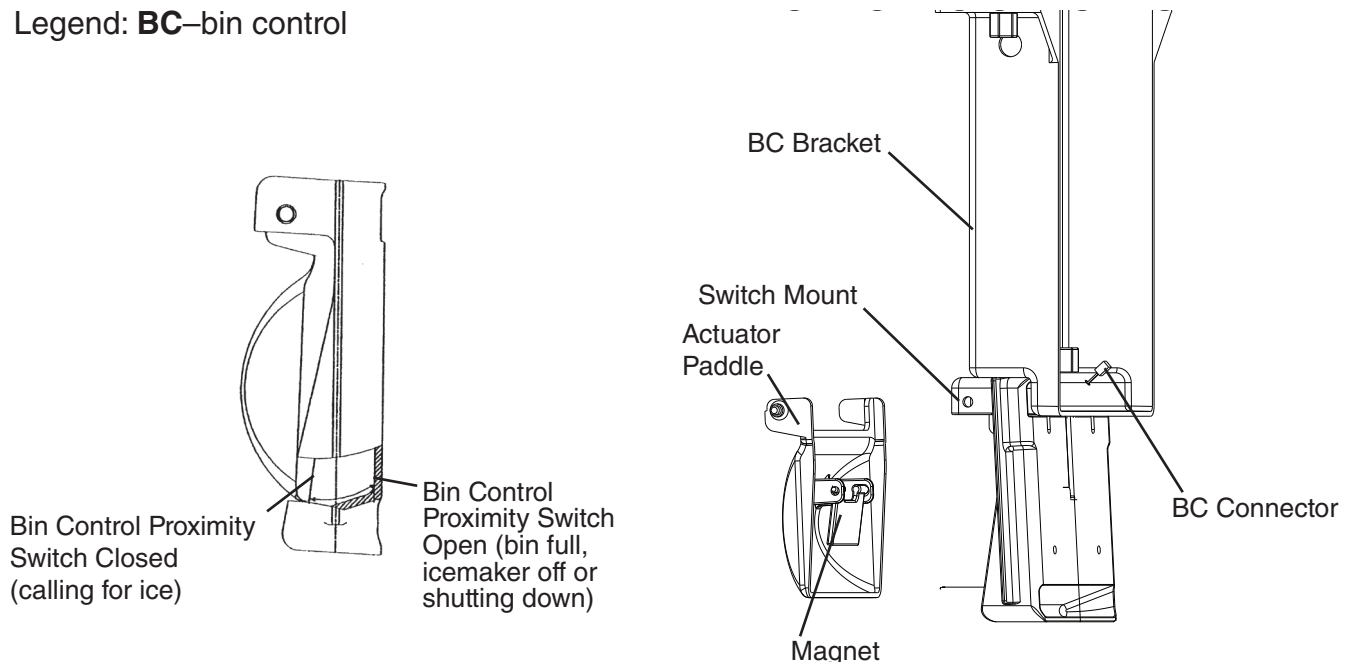

**Fig. 2**

## E. Float Switch Check and Cleaning

FS is used to determine that there is sufficient water in the water tank after the 1-min. fill cycle and after each harvest cycle. FS is also used to determine that the appropriate volume of water has been converted into ice before switching out of the freeze cycle. No adjustment is required.

### 1. Float Switch Check

To check FS, follow the steps below.

- 1) Turn off the power supply.
- 2) Remove the front panel, then move the control switch to the "OFF" position.
- 3) Remove the insulation panel, then remove the drain plug located on the lower front part of the ice chute. See Fig. 3. Allow the water tank to drain.
- 4) Replace the drain plug in its correct position. Be careful not to cross thread it.
- 5) Remove the control box cover.
- 6) Disconnect FS connector from CB K5 connector.
- 7) Check for continuity across FS leads. With the water tank empty, FS should be open. If open, continue to step 8. If closed, follow the steps in "II.E.2. Float Switch Cleaning." After cleaning FS, check it again. Replace if necessary.
- 8) Reconnect FS connector to CB K5 connector, then replace the control box cover in its correct position.
- 9) Move the control switch to the "ICE" position. Replace the insulation panel and front panel in their correct positions, then turn on the power supply. After 1 min., the 1-min. fill cycle should end and the initial harvest cycle should begin. If the initial harvest cycle begins, FS is good and the check is complete. If the initial harvest cycle does not begin, continue to step 10.
- 10) Turn off the power supply.
- 11) Remove the front panel. Move the control switch to the "OFF" position.
- 12) Remove the control box cover.
- 13) Disconnect FS connector from CB K5 connector.
- 14) Check for continuity across FS leads. With the water tank full, FS should be closed. If FS is closed and the icemaker will not switch from the 1-min. fill cycle to the initial harvest cycle, replace CB.

If FS is open, confirm that the water tank is full. If the water tank is not full, check the water supply, water filters, and inlet water valve. If the water tank is full, follow the steps in "II.E.2. Float Switch Cleaning." After cleaning FS, check it again. Replace if necessary.

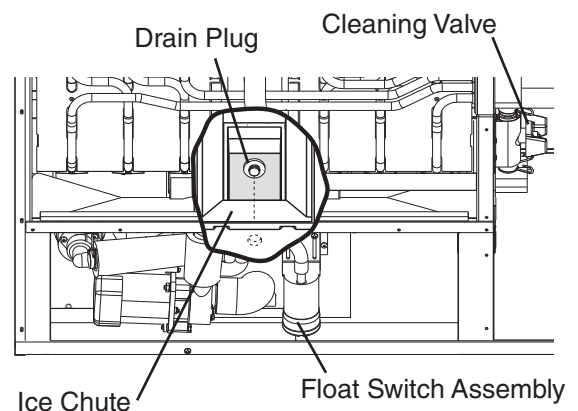

**Fig. 3**

Legend: **CB**—control board; **FS**—float switch

## 2. Float Switch Cleaning

Depending on local water conditions, scale may build up on FS. Scale on the switch can cause the float to stick. In this case, FS should be cleaned.

- 1) Turn off the power supply.
- 2) Remove the front panel, then move the control switch to the "OFF" position.
- 3) Remove the insulation panel, then remove the drain plug located on the lower front part of the ice chute. See Fig. 3. Allow the water tank to drain.
- 4) Replace the drain plug in its correct position. Be careful not to cross thread it.
- 5) Disconnect the vent tube and the flush tube from the top of FS, then remove FS assembly and remove the rubber boot from the bottom of FS assembly. See Fig. 4.
- 6) Remove the retainer rod from the bottom of FS housing, then remove the float. Be careful not to bend the retainer rod excessively when removing it.
- 7) Wipe down FS housing, shaft, float, and retainer rod with a mixture of 1 part Hoshizaki "Scale Away" and 25 parts warm water. Clean the inside of the rubber boot and hose with cleaning solution. Rinse the parts thoroughly with clean water.
- 8) Reassemble FS assembly and replace it and the rubber boot in their correct positions. Reconnect the vent tube and the flush tube.
- 9) Move the control switch to the "ICE" position.
- 10) Replace the insulation panel and front panel in their correct positions.
- 11) Turn on the power supply to start the automatic icemaking process.

Legend: **CB**–control board; **FS**–float switch

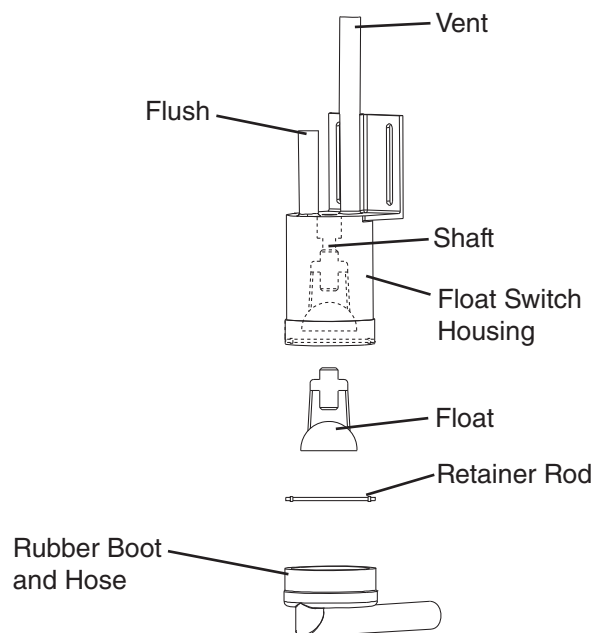

**Fig. 4**

## F. Thermistor Check

To check thermistor resistance, follow the steps below.

- 1) Turn off the power supply.
- 2) Remove the front panel. Move the control switch to the "OFF" position.
- 3) Remove the control box cover.
- 4) Remove the thermistor from the refrigerant tubing.
- 5) Immerse the thermistor sensor portion in a glass containing ice and water for 2 or 3 min.
- 6) Disconnect the thermistor connector from CB K3 connector and check the resistance between thermistor leads. Normal range is 4.7 to 6.2 k $\Omega$ . If outside the normal range, replace the thermistor. See "IV.B. Component Service Information." If within the normal range, continue to the next step.
- 7) Replace the thermistor in its correct position. See "IV.B. Component Service Information."
- 8) Reconnect the thermistor connector to CB K3 connector.
- 9) Replace the control box cover in its correct position.
- 10) Move the control switch to the "ICE" position.
- 11) Replace the front panel in its correct position.
- 12) Turn on the power supply.
- 13) Once the harvest cycle starts (Comp energizes), begin timing the harvest cycle.
- 14) The harvest timer and harvest cycle should terminate within 2 to 5 min. If the harvest cycle does not terminate within 2 to 5 min., replace CB.

Legend: **CB**—control board; **Comp**—compressor

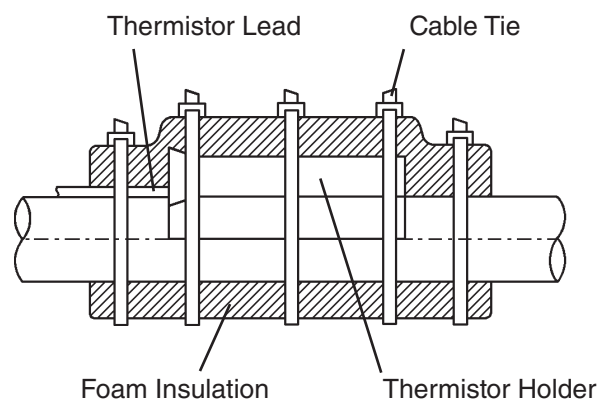

**Fig. 5**

## G. Control Switch

The control switch has three positions: "OFF" for power off, "ICE" for icemaking, and "WASH" to energize the pump motor when cleaning and sanitizing. **WARNING! Control switch in "OFF" position does not de-energize all loads. Risk of electric shock. Use extreme caution and exercise safe electrical practices.**

## H. Diagnostic Tables

### 1. No Ice Production

No Ice Production - Possible Cause	
1. Power Supply	a) Off, blown fuse, or tripped breaker.
	b) Not within specifications.
2. Main Transformer	a) Voltage tap switch not set to proper voltage.
	b) Coil winding open or shorted.
3. Fuse (Control Box)	a) Blown.
4. Control Switch	a) In "OFF" or "WASH" position.
	b) Bad contacts.
5. High-Pressure Switch	a) Dirty condenser.
	b) Fan motor not operating.
	c) Refrigerant overcharged.
	d) Bad contacts.
	e) Refrigerant lines or components plugged.
6. Control Transformer (115VAC/10.5VAC)	a) Coil winding open or shorted.
7. Control Board See "II.C. Control Board Check"	a) In alarm.
	b) Yellow "BC OPEN" LED on (bin full).
	c) Defective.
8. Bin Control See "II.D. Bin Control Check."	a) Tripped with bin filled with ice.
	b) Actuator does not move freely.
	c) Defective.
9. Water Supply	a) Water supply off or improper water pressure.
	b) External water filters clogged.
10. Inlet Water Valve	a) Screen or orifice clogged.
	b) Coil winding open.
	c) Water valve open in freeze cycle.
11. Float Switch See "II.E. Float Switch Check and Cleaning"	a) Float does not move freely.
	b) Defective.
12. Compressor	a) Compressor relay/magnetic contactor contacts bad or coil winding open.
	b) Start capacitor or run capacitor defective (single phase model).
	c) Internal protector open.
	d) Start relay contacts bad or coil winding open (single phase model).
	e) Compressor defective.
13. Hot Gas Valve	a) Closed in harvest cycle.
	b) Open in freeze cycle.
14. Thermistor See "II.F. Thermistor Check"	a) Loose, disconnected, or defective.
15. Pump Motor	a) Motor winding open.
	b) Bearing worn out or locked rotor.
	c) Defective capacitor.
	d) Mechanical seal worn out.

<b>No Ice Production - Possible Cause</b>	
16. Thermostatic Expansion Valve	a) Bulb loose.
	b) Operating erratically.
17. Liquid Line Valve	a) Closed in freeze cycle.
	b) Open in harvest cycle.
18. Fan Motor	a) Motor winding open.
	b) Bearing worn out or locked rotor.
	c) Defective capacitor.
19. Water System	a) Water leaks causing short freeze time.

## 2. Low Ice Production

<b>Low Ice Production - Possible Cause</b>	
<b>Long Harvest Cycle</b>	
1. Evaporator	a) Scaled up.
2. Spray Tubes and/or Spray Guides	a) Dirty.
	b) Out of position.
3. Refrigerant Charge	a) Low.
4. Water Supply	a) Low water pressure.
	b) External water filters clogged.
	c) Insufficient water line size. Minimum 3/8" Nominal ID (10 mm Nominal OD in the EU) water tubing or equivalent.
	d) Too cold.
5. Control Board See "II.C. Control Board Check"	a) Thermistor connection loose (K3).
	b) Defective.
6. Thermistor See "II.F. Thermistor Check"	a) Loose, disconnected, or defective.
7. Hot Gas Valve	a) Erratic or closed.
8. Inlet Water Valve	a) Screen or orifice clogged.
9. Compressor	a) Inefficient or off.
10. Liquid Line Valve	a) Erratic or open.
11. Thermostatic Expansion Valve	a) Defective.
<b>Short Freeze Cycle</b>	
1. Low Water Supply	a) Water filters clogged.
2. Inlet Water Valve	a) Screen or orifice clogged.
3. Float Switch	a) Float does not move freely.
	b) Defective.
4. Splash Guard	a) Missing or defective.
5. Check Valve	a) Dirty.
	b) Defective.
6. Control Board	a) Defective.

<b>Low Ice Production - Possible Cause</b>	
<b>Long Freeze Cycle</b>	
1. Evaporator	a) Scaled up, dirty.
2. Float Switch See "II.E. Float Switch Check and Cleaning"	a) Scaled up, dirty.
	b) Float sticking.
	c) Defective switch.
3. Inlet Water Valve	a) Leaking by.
4. Hot Gas Valve	a) Erratic or open.
5. Condenser	a) Clogged.
6. Control Board See "II.C. Control Board Check"	a) Float switch connection loose (K5).
	b) Defective.
7. Refrigerant Charge	a) Low.
8. Thermostatic Expansion Valve	a) Bulb loose.
	b) Defective.
9. Compressor	a) Inefficient or off.
10. Pump Motor	a) RPM too slow.
11. Liquid Line Valve	a) Erratic or restricted.

### 3. Freeze-Up

Defrost and clean the icemaker prior to diagnosing freeze-up. Fill out a freeze-up checklist. See "II.I. Freeze Up Check List," the Hoshizaki America Technician's Pocket Guide, or contact your local distributor for a copy of the freeze-up checklist.

<b>Freeze-Up - Possible Cause</b>	
<b>Harvest Cycle</b>	
1. Evaporator	a) Scaled up.
	b) Damaged.
2. Cube Guides or Splash Guards	a) Out of position.
	b) Damaged.
3. Spray Tubes and/or Spray Guides	a) Dirty.
	b) Out of position.
4. Water Supply	a) Low water pressure.
	b) External water filters clogged.
	c) Insufficient water line size. Minimum 3/8" Nominal ID (10 mm Nominal OD in the EU) copper water tubing or equivalent.
5. Inlet Water Valve	a) Screen or orifice clogged.
	b) Defective.
6. Float Switch See "II.E. Float Switch Check and Cleaning"	a) Dirty, sticking.
	b) Defective.
7. Refrigerant Charge	a) Low.

<b>Freeze-Up - Possible Cause</b>	
8. Control Board See "II.C. Control Board Check" and "III.C. Settings and Adjustments"	a) Harvest timer (S4 dip switch 1 & 2) set too short.
	b) Harvest pump time (harvest assist) (S4 dip switch 7) not in factory default position.
	c) Defective.
9. Bin Control See "II.D. Bin Control Check"	a) Actuator does not move or defective.
10. Thermistor See "II.F. Thermistor Check"	a) Loose, disconnected, or defective.
11. Thermostatic Expansion Valve	a) Defective.
12. Hot Gas Valve	a) Closed or restricted.
13. Liquid Line Valve	a) Open.
<b>Freeze Cycle</b>	
1. Evaporator	a) Scaled up.
	b) Damaged.
2. Spray Tubes and/or Spray Guides	a) Dirty.
	b) Out of position.
3. Refrigerant Charge	a) Low.
4. Control Board See "II.C. Control Board Check"	a) Freeze timer (S4 dip switch 9 & 10) set incorrectly.
	b) Defective.
5. Inlet Water Valve	a) Leaking by.
6. Float Switch See "II.E. Float Switch Check and Cleaning"	a) Float does not move freely.
	b) Defective.
7. Pump Motor	a) RPM too slow.
	b) Impeller damaged.
8. Thermostatic Expansion Valve	a) Bulb loose or defective.
9. Liquid Line Valve	a) Restricted.

# I. Freeze-Up Check List

PLEASE COMPLETE WHEN DIAGNOSING A FREEZE-UP  
**REFRIGERANT LEAK OR LOW CHARGE**  
 TECHNICAL SUPPORT FAX 1-800-843-1056

“MAKE COPIES AND USE AS NEEDED”

MODEL# \_\_\_\_\_ SERIAL# \_\_\_\_\_ INSTALL DATE \_\_\_\_\_ FAIL DATE \_\_\_\_\_

- |   |        |       |  |
|---|--------|-------|--|
|   | Single | Stack |  |
| 1. Single unit or stacked equipment?  | [ ]    | [ ]   | 18. Does the unit have any water filtration? [ ] [ ]<br>If yes please list the following:<br>Filter brand _____ Model _____<br>Filter pressure gauge reading during the fill cycle _____<br>Date filter was last replaced? _____<br>GPM or LPM flow rate of filter system? _____ |
| 2. Is the float switch dirty?   | [ ]    | [ ]   | 19. Please list the DIP switch settings.<br>1 _____ 2 _____ 3 _____ 4 _____ 5 _____ 6 _____ 7 _____ 8 _____ 9 _____ 10 _____   |
| 3. Is the water pump always running in freeze?  | [ ]    | [ ]   | 20. Is the cube size consistent from inlet to outlet [ ] [ ]<br>of evaporator? _____   |
| 4. Is the thermistor properly mounted?  | [ ]    | [ ]   | 21. Is ice still dropping when the unit goes into freeze [ ] [ ]   |
| 5. Is the TXV bulb tight and insulated?   | [ ]    | [ ]   | 22. After defrosting, was the unit leak checked? [ ] [ ]<br>Were any leaks found? [ ] [ ]<br>If so where? _____  |
| 6. Does the water sump fill to overflow in 60-90 seconds or less when empty? Note: 1800, 2000 2400 should be 60-120 seconds | [ ]    | [ ]   | 23. Was any refrigerant added to the unit? [ ] [ ]<br>If so, how much? _____   |
| 7. Is water line size 1/2"? If not _____”   | [ ]    | [ ]   | 24. What was the head pressure? Freeze _____ Harvest _____<br>(Freeze pressure should be taken 5 minutes into the cycle)   |
| 8. Is the water flow 3GPM for KM-150 to KM-900 or 5GPM for KM-1200-KM-2400?   | [ ]    | [ ]   | 25. What was the suction pressure? Freeze _____ Harvest _____<br>(Freeze pressure should be taken 5 minutes into the cycle)  |
| 9. Only one water line per unit? If not _____   | [ ]    | [ ]   | 26. What was the length of the cycles?<br>Harvest _____ Freeze _____   |
| 11. Will the thermostatic bin control cycle the unit OFF within 6-10 seconds when in contact with ice?                      | [ ]    | [ ]   | 27. Ambient temperature at condenser? _____ °F   |
| 11a. Is the bin control capillary touching a heated surface?  | [ ]    | [ ]   | 28. Water-cooled condenser outlet temperature _____ °F   |
| <b>For units with mechanical style bin control:</b>   |        |       | 29. Is the hot gas valve opening? [ ] [ ]  |
| 12. Will mechanical control cycle unit off in 6 seconds within the first 5 minutes of freeze?                               | [ ]    | [ ]   | 30. List model and manufacture of the bin _____  |
| 12a. Is the deflector shield in place over the control bracket.   | [ ]    | [ ]   | 31. Has the stainless steel extension bracket been added? (All “S” models) [ ] [ ]   |
| 12b. Is DIP switch number 7 ON?   | [ ]    | [ ]   | 32. What is the ice drop weight? _____   |
| 12c. Is machine mounted on a dispenser?   | [ ]    | [ ]   |  |
| 13. Are the evaporator separators positioned properly?  | [ ]    | [ ]   |  |
| 14. Is the cube guide positioned correctly?   | [ ]    | [ ]   |  |
| 15. Date evaporators were last cleaned? _____   |        |       |  |
| 16. Date water valve screen was last cleaned? _____   |        |       |  |
| 16a. Does water valve close completely when de-energized?   | [ ]    | [ ]   |  |
| 17. What is water pressure? _____ Temperature _____   |        |       |  |

Note: Please make copies of this form and use it when diagnosing a freeze up condition.  
Please submit a completed copy of the checklist with any Freeze-up labor claim form

---

### III. Controls and Adjustments

- A Hoshizaki exclusive control board is employed in KM and KMH series appliances.
- All models are pretested and factory adjusted.
- For a control board check procedure, see "II.C. Control Board Check."

<b><i>NOTICE</i></b>
<ul style="list-style-type: none"><li>• Fragile, handle very carefully.</li><li>• The control board contains integrated circuits, which are susceptible to failure due to static discharge. It is especially important to touch the metal part of the icemaker when handling or replacing the control board.</li><li>• Do not touch the electronic devices on the control board or the back of the control board.</li><li>• Do not change wiring and connections. Do not misconnect K3 WHITE, K4 RED, and K5 BLACK, because the same connector is used for the thermistor, mechanical bin control, and float switch.</li><li>• Do not short out power supply to test for voltage.</li><li>• Always replace the whole control board assembly if it goes bad.</li></ul>

# A. Control Board Layout

## "J" Control Board

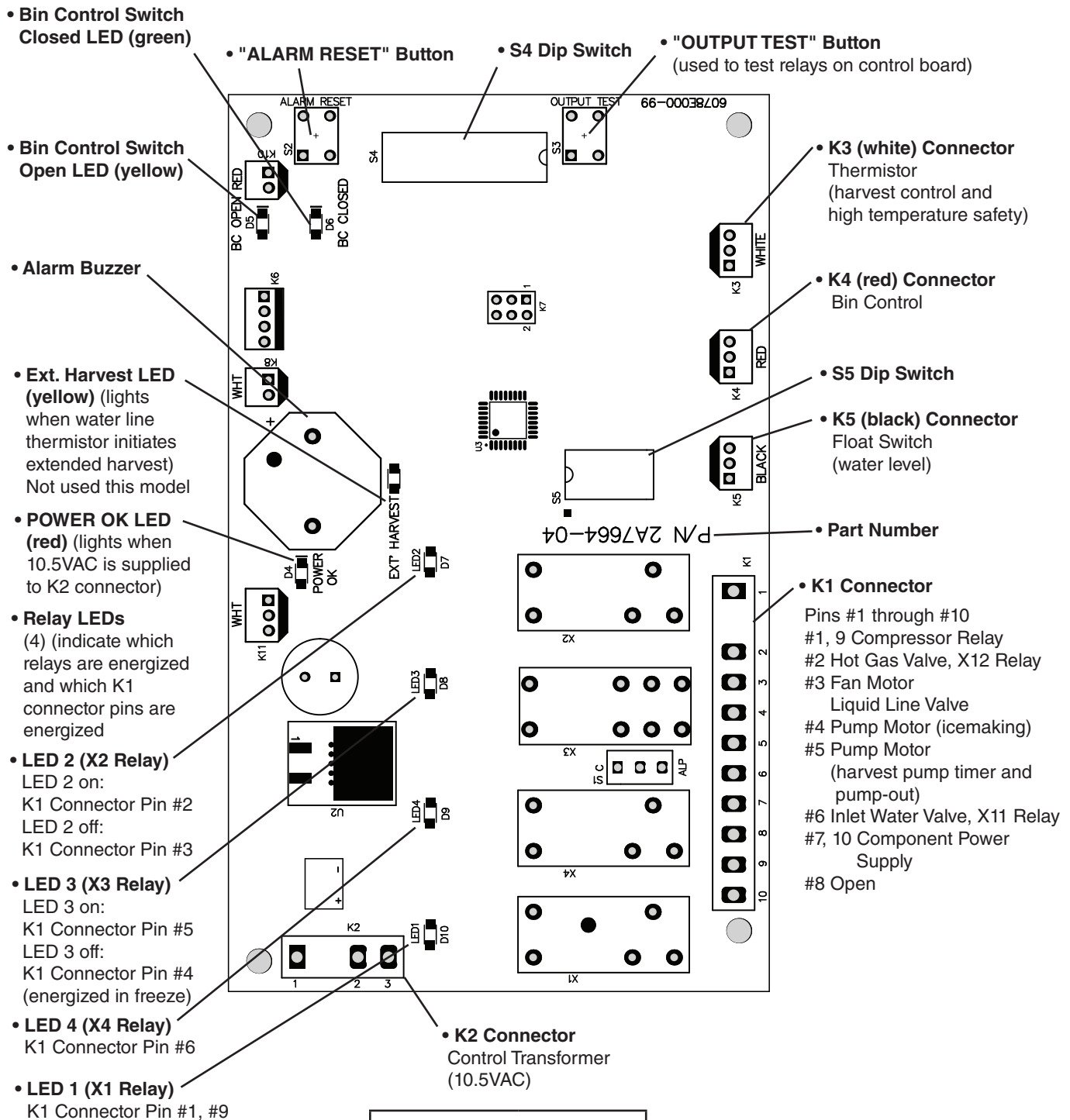

"J" Control Board	
Part Number	2A7664-04

## B. LED Lights and Audible Alarm Safeties

Beep occurs and red "POWER OK" LED turns on when control switch is moved to "ICE" position.

### Sequence

Green LEDs 1 through 4 turn on and sequence from initial startup as listed in the table below. Order of green LEDs from the outer edge of control board is 1, 4, 3, 2.

Sequence Step	LED	Energized Components	Time LEDs are On	
			Min.	Max.
1-Minute Fill Cycle	4	WV		
Harvest Cycle	1, 4, 2	Comp, HGV, WV	1 minute	20 minutes
Harvest Pump Time (harvest assist)	1, 3, 2	Comp, HGV, PM	0 seconds	50 seconds
Freeze Cycle	1	Comp, FM, PM, LLV	5 minutes	freeze timer setting
Slush Control	1, 3	Comp, FM, LLV	If S5 dip switch 5 on, PM off 10 sec. when thermistor at 36°F (2.2°C)	
Pump-Out Cycle	1, 4 <sup>†</sup> , 3, 2	Comp, HGV, PM, WV <sup>†</sup>	10 seconds	20 seconds

<sup>†</sup>pump-out timer setting

### Alarms

Type	Alarm	Notes
1 Beep	High Evaporator Temp. (temperature > 127°F) (53°C)	Check for harvest problem (stuck HGV or relay), hot water entering unit, stuck HM, or shorted thermistor.
2 Beep	Harvest Backup Timer (harvest > 20 min. for two cycles in a row)	Check thermistor (open), HGV not opening, TXV or LLV leaking by, low charge, inefficient Comp.
3 Beep	Freeze Timer (freeze > freeze timer setting for two cycles in a row)	Check FS stuck closed (up), WV leaking by, HGV leaking by, PM not pumping, TXV defective, LLV not opening, low charge, or inefficient Comp.
To reset above safeties, press "ALARM RESET" button with power supply on.		
6	Low Voltage (92Vac±5% or less)	Red LED turns off if voltage protection operates. Control voltage safeties automatically reset when voltage is corrected.
7	High Voltage (147Vac±5% or more)	

Legend: **CB**–control board; **Comp**–compressor; **FM**–fan motor; **FS**–float switch; **HGV**–hot gas valve; **LLV**–liquid line valve; **PM**–pump motor; **TXV**–thermostatic expansion valve; **WV**–inlet water valve

## C. Settings and Adjustments

### **NOTICE**

Dip switches are factory set. Failure to maintain factory settings may adversely affect performance and warranty coverage. For more information, contact your Hoshizaki Service Center.

### 1. Default Dip Switch Settings

The dip switches are factory-adjusted to the following positions:

S4 Dip Switch										
S4 Dip Switch No.	1	2	3	4	5	6	7	8	9	10
KM-1301SAJ-E	OFF	OFF	ON	ON	ON	ON	ON	OFF	ON	ON

S5 Dip Switch (Do Not Adjust)					
S5 Dip Switch No.	1	2	3	4	5
KM-1301SAJ-E	OFF	OFF	OFF	OFF	OFF

### **S4 Dip Switch "J" Control Board**

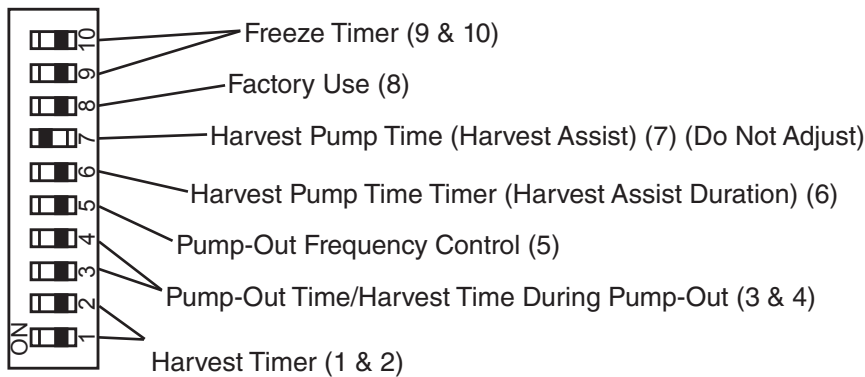

### **S5 Dip Switch (Do Not Adjust) "J" Control Board**

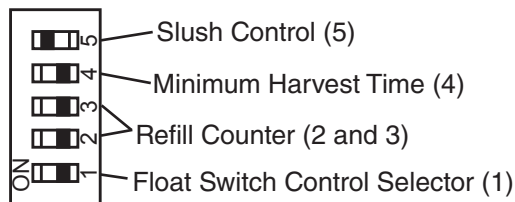

## 2. Harvest Time (S4 dip switch 1 & 2)

The harvest timer starts counting when the thermistor reaches 48°F (9°C) at the evaporator outlet and the control board reads 3.9 kΩ from the thermistor. The harvest timer is factory set, and generally no adjustment is required. However, a setting longer than the factory setting may be advised in cases where the drain provided at harvest needs to be prolonged for extra cleaning. Note that the pump-out timer (S4 dip switch 3 & 4) acts in place of the harvest timer during cycles with a pump out. For details, see "III.C.3. Pump-Out Timer (S4 dip switch 3 & 4)."

Note: On models with a pump-out every cycle, the harvest timer is only relevant during the initial harvest cycle since a pump out occurs every cycle thereafter.

S4 Dip Switch Setting		Time (sec.)	
No. 1	No. 2	S5-4 OFF	S5-4 ON
OFF	OFF	60	30
ON	OFF	90	45
OFF	ON	120	60
ON	ON	180	75

## 3. Pump-Out Time/Harvest Time During Pump-Out (S4 dip switch 3 & 4)

### **NOTICE**

Do not adjust 3 off and 4 on. Pump motor does not run in pump-out rotation in this setting.

When a pump-out is called for, the pump motor stops for 2 sec., then energizes in the reverse direction, taking water from the bottom of the water tank and forcing pressure against the check valve seat allowing water to go through the check valve and down the drain. At the same time, water flows through the small tube to power flush the float switch. The pump motor drains the water tank for the time determined by the pump-out timer. The pump-out timer also acts in place of the harvest timer during cycles with a pump-out. The pump-out timer is factory set, and generally no adjustment is required. However, where water quality is bad and the icemaker needs a longer pump-out time, the pump-out timer can be adjusted. The pump-out time can be set to pump-out for 10 or 20 sec. During pump-out cycles minimum harvest time is based on times given in the table below.

S4 Dip Switch Setting		Time (sec.)			Inlet Water Valve	
No. 3	No. 4	T1	T2		S5-4 OFF	S5-4 ON
			S5-4 OFF	S5-4 ON		
OFF	OFF	10	150	100	Closed	Closed
ON	OFF	10	180	130	Closed	Closed
OFF	ON	10	120	70	Open	Closed
ON	ON	20	180	180	Closed	Closed

T1: Time to drain the water tank

T2: Harvest timer at pump out

**4. Pump-Out Frequency Control (S4 dip switch 5)**

The pump-out frequency control is factory set to drain the water tank every 10 cycles. Generally no adjustment is required. However, where water quality is bad and the icemaker needs a pump-out more often, the pump-out frequency can be adjusted. The pump-out frequency control can be set to have a pump-out occur every cycle, or every 10 cycles.

The first pump-out is dependent on S4 dip switch 5. See the table below.

S4 Dip Switch Setting	Pump-Out Frequency	1st Pump-Out
No. 5		
OFF	Every 10 cycles	After 11th freeze cycle
ON	Every cycle	After 2nd freeze cycle

**5. Harvest Pump Time (Harvest Assist) (S4 dip switch 6)**

<b>NOTICE</b>
Factory set for proper operation. Do not adjust. Adjustment outside of the factory default setting may result in damage to the appliance.

Harvest pump time (harvest assist) is only active when S4 dip switch 7 is in the "ON" position. In the factory default position, the harvest pump time (harvest assist) starts with 50 sec. left to go in harvest cycle (S4 dip switch 6) and after the thermistor reaches 48°F (9°C) at the evaporator outlet and the control board reads 3.9 kΩ from the thermistor. The harvest pump time (harvest assist) is factory set, and no adjustment is required.

S4 Dip Switch Setting	Harvest Pump Time (Harvest Assist)	
	S5-4 OFF	S5-4 ON
No. 6		
OFF	50 sec.	25 sec.
ON	25 sec.	15 sec.

## 6. Harvest Pump Time (Harvest Assist) (S4 dip switch 7)

### **NOTICE**

Factory set for proper operation. Do not adjust. Adjustment outside of the factory default setting may result in damage to the appliance.

Depending on S4 dip switch 7 setting, the pump motor either stays off or is energized during the last seconds of the harvest cycle. When the pump motor is energized (S4 dip switch 7 on), water circulates over the evaporator. The harvest water valve is open during harvest for a maximum of 6 minutes or the length of harvest minus the harvest pump time value(S4 dip switch 6), whichever is shorter.

When S4 dip switch 7 is in the on position and harvest begins, X11 and X10 relays energize. A latching circuit is created through the X11 and X10 relays. For further details, see "VIII.B. Wiring Diagrams." In the factory default position, 50 sec. before harvest termination, LED 4 turns off, inlet water valve and X11 relay de-energize. X10 relay remains energized through the latching circuit. Next, LED 3 turns on and control board K1 connector pin #5 (DBU wire) energizes, energizing the pump motor for the last seconds of harvest. Harvest pump time adjusted by S4 dip switch 1 & 2 and S5 dip switch 4 settings. Contact Technical Support before adjusted these settings.

<b>S4 Dip Switch Setting</b>	<b>Harvest Pump Time</b>
<b>No. 7</b>	<b>(Harvest Assist)</b>
OFF	Disabled
ON	Enabled

## 7. Factory Use (S4 dip switch 8)

Factory set for proper operation. Do not adjust. This must be left in the factory default position.

## 8. Freeze Timer (S4 dip switch 9 & 10)

### **NOTICE**

Adjust to proper specification, or the icemaker may not operate correctly.

The freeze timer setting determines the maximum allowed freeze time to prevent possible freeze-up issues. Upon termination of the freeze timer, the control board initiates the harvest cycle or pump-out cycle. After 2 consecutive freeze timer terminations, the control board shuts down the icemaker. In this case, see "II.H.3. Low Ice Production" for possible solutions. The freeze timer is factory set and no adjustment is required. Before changing this setting, contact Hoshizaki Technical Support at 1-800-233-1940 for recommendations.

S4 Dip Switch Setting		Time (min.)
No. 9	No. 10	
OFF	OFF	60
OFF	ON	50
ON	OFF	70
ON	ON	75

## 9. Float Switch Control Selector (S5 dip switch 1)

### **NOTICE**

Do not adjust. This must be left in the factory default position or the icemaker will not operate correctly. The KM-1301SAJ-E uses a single float switch with no refills.

Float switch selector used in applications where refill is required in the freeze cycle. Refills set by S5 dip switch 2 and 3. Note: In single float switch with upper float operation only 1 refill allowed.

- Single float switch application:
  - With S5 dip switch 1 in the "OFF" position, control board monitors the lower float switch for refill operation.
  - With S5 dip switch 1 in the "ON" position, the control board monitors the upper float switch for refill operation. In this case no upper float switch exists, therefore the control board reads an open upper float switch immediately when the freeze cycle starts and initiates a refill. Since there is no upper float switch to close and terminate the refill, the refill lasts for a maximum of 1-min. During the 1-min. refill, LED 4 is on.
- Double float switch application: Float switch control selector determines which float switch (upper or lower) the control board monitors for refill control during the freeze cycle.

S5 Dip Switch Setting	Pump-Out Components
No. 1	
OFF	Bottom Float Switch Control
ON	Top Float Switch Control (this setting is ignored if refill counter (S5 dip switch 2 and 3) set to 0)

## 10. Refill Counter (S5 dip switch 2 and 3)

### **NOTICE**

Do not adjust. These must be left in the factory default position or the icemaker will not operate correctly.

S5 Dip Switch Setting		Refill Counter
No. 2	No. 3	
OFF	OFF	0
OFF	ON	1 refill
ON	OFF	9 refills
ON	ON	10 refills

## 11. Minimum Harvest Time (S5 dip switch 4)

### **NOTICE**

Factory set for proper operation. Do not adjust. Adjustment outside the factory default setting may result in damage to the appliance.

S5 Dip Switch Setting	Minimum Harvest Timer
No. 4	
OFF	120 sec.
ON	70 sec.

## 12. Slush Control (S5 dip switch 5)

### **NOTICE**

Factory set for proper operation. Do not adjust. Adjustment outside the factory default setting may result in damage to the appliance.

This dip switch setting provides slush control during the freeze cycle. When the evaporator temperature reaches 36°F (2.2°C) the control board reads a 5.8kΩ signal from the thermistor and de-energizes the water pump for 10 sec. to melt ice slush and prevent ice slush from blocking the water supply tubing, causing irregular freeze patterns.

S5 Dip Switch Setting	Slush Control
No. 5	
OFF	Disabled
ON	Enabled

## IV. Refrigeration Circuit and Component Service Information

### **WARNING**

- This appliance should be diagnosed and repaired only by qualified service personnel to reduce the risk of death, electric shock, serious injury, or fire.
- Move the control switch to the "OFF" position and turn off the power supply. Place the disconnect in the "OFF" position. Lockout/Tagout to prevent the power supply from being turned back on inadvertently.
- **CHOKING HAZARD:** Ensure all components, fasteners, and thumbscrews are securely in place after the icemaker is serviced. Make sure that none have fallen into the dispenser unit/ice storage bin.
- Make sure all food zones in the icemaker and dispenser unit/ice storage bin are clean after service.

### A. Refrigeration Circuit Service Information

#### **WARNING**

- Repairs requiring the refrigeration circuit to be opened must be performed by properly trained and EPA-certified service personnel.
- Use an electronic leak detector or soap bubbles to check for leaks. Add a trace of refrigerant to the system (if using an electronic leak detector), and then raise the pressure using nitrogen gas (140 PSIG). Do not use R-404A as a mixture with pressurized air for leak testing.

#### **NOTICE**

- Always recover the refrigerant and store it in an approved container. Do not discharge the refrigerant into the atmosphere.
- Do not leave the system open for longer than 15 min. when replacing or servicing parts. The Polyol Ester (POE) oils used in R-404A applications can absorb moisture quickly. Therefore it is important to prevent moisture from entering the system when replacing or servicing parts.
- Always install a new drier every time the sealed refrigeration system is opened. Do not replace the drier until after all other repair or replacement has been made. Install the new drier with the arrow on the drier in the direction of the refrigerant flow.
- When brazing, protect the drier by using a wet cloth to prevent the drier from overheating. Do not allow the drier to exceed 250°F (121°C).

#### 1. Refrigerant Recovery

The icemaker is provided with refrigerant service valves. Using proper refrigerant practices, recover the refrigerant. Store the refrigerant in an approved container. Do not discharge the refrigerant into the atmosphere.

## 2. Brazing

### **⚠ WARNING**

- R-404A itself is not flammable at atmospheric pressure and temperatures up to 176°F (80°C).
- R-404A itself is not explosive or poisonous. However, when exposed to high temperatures (open flames), R-404A can be decomposed to form hydrofluoric acid and carbonyl fluoride both of which are hazardous.
- Do not use silver alloy or copper alloy containing arsenic.

1) Brazing all fittings while purging with nitrogen gas flowing at a pressure of 3 to 4 PSIG.

Note: Because the pipes in the evaporator case are specially coated to resist corrosion, it is important to make connections outside the evaporator case when possible. If it is necessary to braze inside the evaporator case, use sandpaper to remove the coating from the brazing connections before unbrazing the components.

### **NOTICE**

- Always install a new drier every time the sealed refrigeration system is opened.
- Do not replace the drier until after all other repair or replacement has been made. Install the new drier with the arrow on the drier in the direction of the refrigerant flow.
- When brazing, protect the drier by using a wet cloth to prevent the drier from overheating. Do not allow the drier to exceed 250°F (121°C).

2) Use an electronic leak detector or soap bubbles to check for leaks. Add a trace of refrigerant to the system (if using an electronic leak detector), and then raise the pressure using nitrogen gas (140 PSIG). Do not use R-404A as a mixture with pressurized air for leak testing.

## 3. Evacuation and Recharge (R-404A)

1) Attach a vacuum pump to the system. Be sure to connect the charging hoses to both high and low-side refrigerant access valves.

### **IMPORTANT**

The vacuum level and vacuum pump may be the same as those for current refrigerants. However, the rubber hose and gauge manifold to be used for evacuation and refrigerant charge should be exclusively for POE oils.

2) Turn on the vacuum pump. Open the gauge manifold valves, then open the high and low-side service valves. Never allow the oil in the vacuum pump to flow backwards.

3) Allow the vacuum pump to pull down to a 29.9" Hg vacuum. Evacuating period depends on pump capacity.

4) Close the low-side valve and high-side valve on the gauge manifold.

- 5) Disconnect the gauge manifold hose from the vacuum pump and attach it to a refrigerant service cylinder. Remember to loosen the connection and purge the air from the hose. For the required refrigerant charge, see the rating label inside the icemaker. Hoshizaki recommends only virgin refrigerant or reclaimed refrigerant which meets ARI Standard 700 (latest edition) be used.
- 6) A liquid charge is required when charging an R-404A system (to prevent fractionation). Place the service cylinder on the scales; if the service cylinder is not equipped with a dip tube, invert the service cylinder, then place it on the scales. Open the high-side valve on the gauge manifold.
- 7) Allow the system to charge with liquid until the proper charge weight is met.
- 8) If necessary, add any remaining charge to the system through the low-side.  
**NOTICE! To prevent compressor damage, use a throttling valve or liquid dispensing device to add the remaining liquid charge through the low-side refrigerant service valve with the icemaker running.**
- 9) Close the high and low-side service valves, then close the high and low-side gauge manifold valves. Disconnect the gauge manifold hoses.
- 10) Cap the refrigerant service valves to prevent a possible leak.

## B. Component Service Information

### **NOTICE**

When replacing a component listed below, see the notes to help ensure proper operation.

<b>Component</b>	<b>Notes</b>
Compressor	1 phase: Install a new start capacitor, run capacitor, and start relay.
Thermostatic Expansion Valves	<ul style="list-style-type: none"> <li>• Attach the thermostatic expansion valve bulb to the suction line in the same location as the previous bulb.</li> <li>• The bulb should be between the 10 and 2 o'clock positions on the tube.</li> <li>• Secure the bulb with the clamp and holder, then insulate it.</li> </ul>
Hot Gas Valves Liquid Line Valves	<ul style="list-style-type: none"> <li>• Replace the strainer if applicable.</li> <li>• Use copper tube of the same diameter and length when replacing valve lines.</li> </ul>
Fan Motors	Install a new capacitor.
Pump Motor	Install a new capacitor.
Thermistor	<ul style="list-style-type: none"> <li>• Attach the new thermistor to the suction line in the same location as the previous thermistor.</li> <li>• The thermistor should be at the 12 o'clock position on the tube.</li> <li>• Smoothly fill the recessed area of the thermistor holder with high thermal conductive type sealant. Hoshizaki America part number <a href="#">4A0683-01</a> (Silicone Heat Sink Compound 10-8108 manufactured by GC Electronics), KE-4560 RTV (manufactured by ShinEtsu Silicones), or equivalent are recommended.</li> <li>• Secure the thermistor with the holder, then insulate it.</li> <li>• Be very careful to prevent damage to the leads.</li> </ul>

## V. Maintenance

The maintenance schedule below is a guideline. More frequent maintenance may be required depending on water quality, the appliance's environment, and local sanitation regulations

### WARNING

- Only qualified service technicians should service the appliance.
- To reduce the risk of electric shock, do not touch the control switch or service switch with damp hands
- Before servicing: Move the control switch to the "OFF" position and turn off the power supply. Place the disconnect in the "OFF" position. Lockout/Tagout to prevent the power supply from being turned back on inadvertently.
- **CHOKING HAZARD:** Ensure all components, fasteners, and thumbscrews are securely in place after any maintenance is done to the icemaker. Make sure that none have fallen into the dispenser unit/ice storage bin.

### Maintenance Schedule

Frequency	Area	Task
Daily	Scoop	Clean the ice scoop using a neutral cleaner. Rinse thoroughly after cleaning.
Bi-Weekly	Air Filters	Inspect. Wash with warm water and neutral cleaner if dirty.
Monthly	External Water Filters	Check for proper pressure and change if necessary.
	Icemaker Exterior	Wipe down with a clean, soft cloth. Use a damp cloth containing a neutral cleaner to wipe off oil or dirt build up. Clean any chlorine staining (rust colored spots) using a non-abrasive cleanser.
Yearly	Icemaker and Dispenser Unit/Ice Storage Bin Liner	Clean and sanitize per the cleaning and sanitizing instructions provided in the instruction manual or maintenance label on the icemaker.
	Water Supply Inlet	Close the icemaker water supply line shut-off valve and drain the water system. Clean the water supply inlet screen.
	Condenser	Inspect. Clean if necessary by using a brush or vacuum cleaner. More frequent cleaning may be required depending on location.
	Water Hoses	Inspect the water hoses and clean/replace if necessary.

## VI. Preparing the Icemaker for Periods of Non-Use

### NOTICE

- When storing the appliance for an extended time or in sub-freezing temperatures, follow the instructions below to prevent damage.
- To prevent damage to the water pump, do not operate the appliance with the control switch in the "WASH" position when the water tank is empty.

When the appliance is not used for two or three days under normal conditions, it is sufficient to move the control switch to the "OFF" position. When storing the appliance for an extended time or in sub-freezing temperatures, follow the instructions below.

#### 1. Remove the water from the icemaker water supply line:

- 1) Turn off the power supply, then remove the front panel.
- 2) Move the control switch to the "OFF" position.
- 3) Close the icemaker water supply line shut-off valve, then open the icemaker water supply line drain valve.
- 4) Allow the line to drain by gravity.
- 5) Attach a compressed air or carbon dioxide supply to the icemaker water supply line drain valve.
- 6) Move the control switch to the "ICE" position.
- 7) Replace the front panel in its correct position, then turn on the power supply.
- 8) Blow the icemaker water supply line out using the compressed air or carbon dioxide supply.
- 9) Close the icemaker water supply line drain valve.

#### 2. Drain the water tank:

- 1) Turn off the power supply, then remove the front panel.
- 2) Move the control switch to the "OFF" position.
- 3) Remove the insulation panel. Remove the drain plug located on the lower front part of the ice chute. See Fig. 6. Allow the water tank to drain.
- 4) Replace the drain plug and the insulation panel in their correct positions. Be careful not to cross thread the drain plug.
- 5) Remove all ice from the dispenser unit/ice storage bin. Clean the dispenser unit/ice storage bin liner using a neutral cleaner. Rinse thoroughly after cleaning.
- 6) Replace the front panel in its correct position.

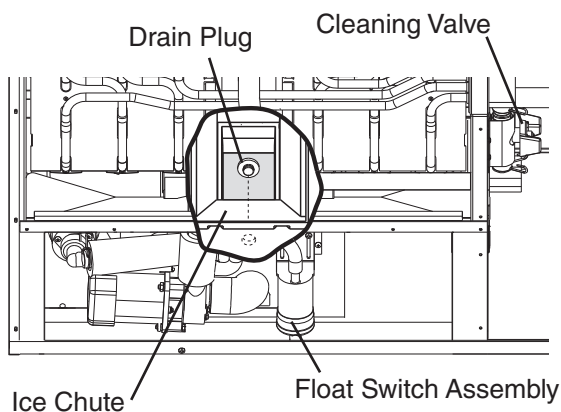

Fig. 6

---

## **VII. Disposal**

The appliance contains refrigerant and must be disposed of in accordance with applicable national, state, and local codes and regulations. Refrigerant must be recovered by properly certified service personnel.

## VIII. Technical Information

We reserve the right to make changes in specifications and design without prior notice.

### A. Specification and Performance Data

Pressure data is recorded at 5 min. into freezing cycle. The data not in bold should be used for reference only.

#### 1. KM-1301SAJ-E

##### Specification Sheet

AC SUPPLY VOLTAGE	220-240/50/1		
AMPERAGE	11.35 A (5 Min. Freeze AT 104°F / WT 80°F)		
MINIMUM CIRCUIT AMPACITY	20 A		
MAXIMUM FUSE SIZE	20 A		
ELECTRIC & WATER CONSUMPTION	90/70°F	70/50°F	
ELECTRIC W (kWH/100 lbs.)	2080 (4.52)	1900 (3.32)	
WATER gal./24HR (gal./100 lbs.)	386 (34.9)	604 (43.9)	
APPROXIMATE ICE PRODUCTION	10/10°C	20/15°C	30/25°C
PER 24 HR. FOR EUROPE MARKET lbs./day (kg/day)	1300 (589)	1356 (615)	1164 (528)
SHAPE OF ICE	Crescent Cube		
ICE PRODUCTION PER CYCLE	36 lbs. (16.3 kg) 1440pcs.		
BIN CONTROL SYSTEM	Mechanical Switch		
REFRIGERANT CHARGE	R404A, 4 lb. 3 oz. (1900g)		

##### Performance Data Sheet

APPROXIMATE ICE PRODUCTION PER 24 HR.	AMBIENT TEMP. (°F/°C)	WATER TEMP. (°F/°C)					
		50/10		70/21		90/32	
	70/21	<b>1375</b>	624	1296	<u>588</u>	1178	535
	80/27	1315	<u>596</u>	1191	<u>540</u>	1069	<u>485</u>
	90/32	1296	<u>588</u>	<b>1105</b>	<u>501</u>	982	<u>445</u>
lbs./day <u>kg./day</u>	100/38	1269	<u>576</u>	1076	<u>488</u>	869	<u>394</u>
APPROXIMATE ELECTRIC CONSUMPTION	70/21	<b>1900</b>		1953		2005	
	80/27	1940		2022		2063	
	90/32	1953		<b>2080</b>		2127	
watts	100/38	1956		2091		2170	
APPROXIMATE WATER CONSUMPTION PER 24 HR.	70/21	<b>604</b>	<u>2.28</u>	540	<u>2.04</u>	493	<u>1.87</u>
	80/27	555	<u>2.10</u>	456	<u>1.73</u>	432	<u>1.63</u>
	90/32	540	<u>2.04</u>	<b>386</b>	<u>1.46</u>	351	<u>1.33</u>
gal./day <u>m<sup>3</sup>/day</u>	100/38	461	<u>1.74</u>	378	<u>1.43</u>	<b>319</b>	<u>1.21</u>
FREEZING CYCLE TIME	70/21	<b>29</b>		31		35	
	80/27	31		34		39	
	90/32	31		<b>37</b>		41	
min.	100/38	32		38		45	
HARVEST CYCLE TIME	70/21	<b>4.0</b>		3.9		3.8	
	80/27	3.9		3.7		3.8	
	90/32	3.9		<b>3.6</b>		3.6	
min.	100/38	3.8		3.6		3.6	
HEAD PRESSURE	70/21	<b>239</b>	<u>16.8</u>	260	<u>18.2</u>	278	<u>19.6</u>
	80/27	255	<u>17.9</u>	287	<u>20.1</u>	300	<u>21.1</u>
	90/32	260	<u>18.2</u>	<b>309</b>	<u>21.7</u>	325	<u>22.9</u>
PSIG <u>kg/cm<sup>2</sup>G</u>	100/38	260	<u>18.3</u>	313	<u>22.0</u>	340	<u>23.9</u>
SUCTION PRESSURE	70/21	<b>51</b>	<u>3.6</u>	53	<u>3.7</u>	56	<u>3.9</u>
	80/27	52	<u>3.7</u>	55	<u>3.9</u>	58	<u>4.1</u>
	90/32	53	<u>3.7</u>	<b>57</b>	<u>4.0</u>	60	<u>4.2</u>
PSIG <u>kg/cm<sup>2</sup>G</u>	100/38	54	<u>3.8</u>	58	<u>4.1</u>	63	<u>4.4</u>
TOTAL HEAT OF REJECTION FROM CONDENSER	16,100 BTU/h [AT 90°F (32°C) / WT 70°F (21°C)]						
TOTAL HEAT OF REJECTION FROM COMPRESSOR	2,600 BTU/h [AT 90°F (32°C) / WT 70°F (21°C)]						

# B. Wiring Diagram

