



HOSHIZAKI

Service Manual

Undercounter Refrigerator

Models
HR24B



hoshizakiamerica.com

Number: 73229
Issued: 3-6-2019
Revised: 4-20-2021

⚠ WARNING

Only qualified service technicians should install and service the appliance. To obtain the name and phone number of your local Hoshizaki Certified Service Representative, visit www.hoshizaki.com. No service should be undertaken until the technician has thoroughly read this Service Manual. Failure to service and maintain the appliance in accordance with this manual will adversely affect safety, performance, component life, and warranty coverage. Proper installation is the responsibility of the installer. Product failure or property damage due to improper installation is not covered under warranty.

Hoshizaki provides this manual primarily to assist qualified service technicians in the service of this appliance.

Should the reader have any questions or concerns which have not been satisfactorily addressed, please call, send an e-mail message, or write to the Hoshizaki Technical Support Department for assistance.

Phone: 1-800-233-1940; (770) 487-2331

Fax: 1-800-843-1056; (770) 487-3360

E-mail: techsupport@hoshizaki.com

HOSHIZAKI AMERICA, INC.

618 Highway 74 South

Peachtree City, GA 30269

Attn: Hoshizaki Technical Support Department

Web Site: www.hoshizaki.com

NOTE: To expedite assistance, all correspondence/communication **MUST** include the following information:

- Model Number _____
- Serial Number _____
- Complete and detailed explanation of the problem.

IMPORTANT

This manual should be read carefully before the appliance is serviced. Read the warnings and guidelines contained in this booklet carefully as they provide essential information for the continued safe use, service, and maintenance of the appliance. Retain this booklet for any further reference that may be necessary.

CONTENTS

Important Safety Information	4
I. General Information	7
A. Construction	7
1. HR24B.....	7
2. Dimensions and Storage Capacity	8
B. Refrigeration Circuit.....	9
II. Sequence of Operation and Service Diagnosis	10
A. Sequence of Operation Flow Chart.....	10
B. Cabinet Temperature and Defrost	11
C. Display Module Icons	12
D. Control Panel Lockout	12
E. Service Diagnosis	13
F. Control Board and Display Module Check	17
1. Control Board Layout	17
2. Display Module Layout	17
3. Control Board Check	18
G. Thermistor Check.....	19
H. Diagnostic Chart	20
I. Alarm Safeties	22
J. Service Menu.....	23
III. Refrigeration Circuit and Component Service Information	29
A. Refrigeration Circuit Service Information	31
B. Component Service Information.....	34
C. Door Reversal	34
IV. Cleaning and Maintenance Instructions.....	35
A. Cleaning	35
B. Maintenance.....	35
V. Preparing the Appliance for Periods of Non-Use	36
VI. Disposal.....	37
VII. Technical Information.....	38
A. Electrical and Refrigerant Data	38
B. Wiring Diagram.....	39

Important Safety Information

Throughout this manual, notices appear to bring your attention to situations which could result in death, serious injury, damage to the appliance, or damage to property.

⚠ DANGER	Indicates a hazardous situation that, if not avoided, will result in death or serious injury.
⚠ WARNING	Indicates a hazardous situation that, if not avoided, could result in death or serious injury.
NOTICE	Indicates a situation that, if not avoided, could result in damage to the appliance or property.
IMPORTANT	Indicates important information about the use and care of the appliance.

⚠ DANGER

Risk of Fire or Explosion

Flammable Refrigerant Used

- Follow handling instructions carefully in compliance with U.S. government regulations.
- Do not use mechanical devices to defrost.
- Do not puncture refrigerant tubing. Risk of fire or explosion due to puncture of refrigerant tubing; follow handling instructions carefully.
- Component parts shall be replaced with like components.
- Servicing shall be done by factory authorized service personnel to minimize the risk of possible ignition due to incorrect parts or improper service.
- Consult instruction manual / service manual before attempting to install or service this product. All safety precautions must be followed.
- Dispose of properly in accordance with federal or local regulations.
- Do not place any potential ignition sources in or near the appliance.

Risque De Feu Ou D'Explosion

Le Frigorigène Est Inflammable

- Suivre attentivement les instructions de manipulation conformément à la réglementation gouvernementale.
- Ne pas utiliser d'appareils mécaniques pour dégivrer le réfrigérateur.
- Ne pas perforer la tubulure contenant le frigorigène. Risque de feu ou d'explosion si la tubulure contenant le frigorigène est perforée; suivre les instructions de manutention avec soin.
- Les pièces des composants doivent être remplacées par des pièces et accessoires équivalents.
- L'entretien doit être effectué par le personnel de service autorisé par le fabricant afin de minimiser les risques d'inflammation attribuables à l'installation d'une pièce inadéquate ou à la mauvaise exécution du service.
- Consulter le manuel du propriétaire/ guide de réparation avant de tenter une réparation. Toutes les mesures de sécurité doivent être respectées.
- Éliminer conformément aux règlements fédéraux ou locaux.
- Ne placez aucune source d'inflammation potentielle dans ou près de l'appareil.

⚠ WARNING

The appliance should be destined only to the use for which it has been expressly conceived. Any other use should be considered improper and therefore dangerous. The manufacturer cannot be held responsible for injury or damage resulting from improper, incorrect, and unreasonable use. Failure to install, operate, and maintain the appliance in accordance with this manual will adversely affect safety, performance, component life, and warranty coverage.

To reduce the risk of death, electric shock, serious injury, or fire, follow basic precautions including the following:

- Only qualified service technicians should install and service the appliance.
- Wear appropriate personal protective equipment (PPE) when servicing the appliance.
- The appliance must be installed in accordance with applicable national, state, and local codes and regulations.
- Appliance is heavy. Use care when lifting or positioning. Work in pairs when needed to prevent injury or damage. Do not lift using the top section or the door.
- To reduce the risk of electric shock, do not touch the plug with damp hands.
- Unplug the appliance before servicing.
- The appliance requires an independent power supply of proper capacity. See the nameplate for electrical specifications. Failure to use an independent power supply of proper capacity can result in a tripped breaker, blown fuse, damage to existing wiring, or component failure. This could lead to heat generation or fire.

• THE APPLIANCE MUST BE

GROUNDING. The appliance is equipped with a NEMA 5-15 three-prong grounding plug  to reduce the risk of potential shock hazards. It must be plugged into a properly grounded, independent 3-prong wall outlet. If the outlet is a 2-prong outlet, it is your personal responsibility to have a qualified electrician replace it with a properly grounded, independent 3-prong wall outlet. Do not remove the ground prong from the power cord and do not use an adapter plug. Failure to follow these instructions may result in death, electric shock, or fire.

- Do not use an extension cord.
- Do not use an appliance with a damaged power cord. The power cord should not be altered, jerked, bundled, weighed down, pinched, or tangled. Such actions could result in electric shock or fire. To unplug the appliance, be sure to pull the plug, not the cord, and do not jerk the cord.
- The GREEN ground wire in the factory-installed power cord is connected to the appliance. If it becomes necessary to remove or replace the power cord, be sure to connect the power cord's ground wire.
- Do not splash, pour, or spray water directly onto or into the appliance. This might cause short circuit, electric shock, corrosion, or failure.
- Do not make any alterations to the appliance. Alterations could result in electric shock, injury, fire, or damage to the appliance.
- The appliance is not intended for use by persons (including children) with reduced physical, sensory, or mental capabilities, or lack of experience and knowledge, unless they have been given supervision or instruction concerning use of the appliance by a person responsible for their safety.

⚠ WARNING, continued

- Children should be properly supervised around the appliance.
- Do not climb, stand, or hang on the appliance or door or allow children or animals to do so. Do not climb into the appliance or allow children or animals to do so. Death or serious injury could occur or the appliance could be damaged.
- Be careful not to pinch fingers when opening and closing the door. Be careful when opening and closing the door when children are in the area.
- Open and close the door with care. Opening the door too quickly or forcefully may cause injury or damage to the appliance or surrounding equipment.
- Do not use combustible spray or place volatile or flammable substances in or near the appliance. They might catch fire.
- Keep the area around the appliance clean. Dirt, dust, or insects in the appliance could cause harm to individuals or damage to the equipment.
- Do not block air inlets or outlets, otherwise cooling performance may be reduced.
- Do not tightly pack the cabinet. Allow some space between items to ensure good air flow. Also allow space between items and interior surfaces.

NOTICE

- Protect the floor when moving the appliance to prevent damage to the floor.
- Keep ventilation openings, in the appliance enclosure or in the built-in structure, clear of obstruction. Do not place anything on top of the appliance in an undercounter installation. There must be at least 1.5" (4 cm) overhead clearance for proper ventilation. The factory-installed rear bumpers must be in place to ensure proper rear clearance. Blockage of airflow could negatively affect performance and damage the appliance.
- Do not tightly pack the cabinet. Allow some space between items to ensure good air flow. Also allow space between items and interior surfaces.
- Do not store items near the air outlet. They might freeze up and crack or break.
- To prevent deformation or cracks, do not spray insecticide onto the plastic parts or let them come into contact with oil.
- To avoid damage to the gasket, use only the door handle when opening and closing.

I. General Information

A. Construction

1. HR24B

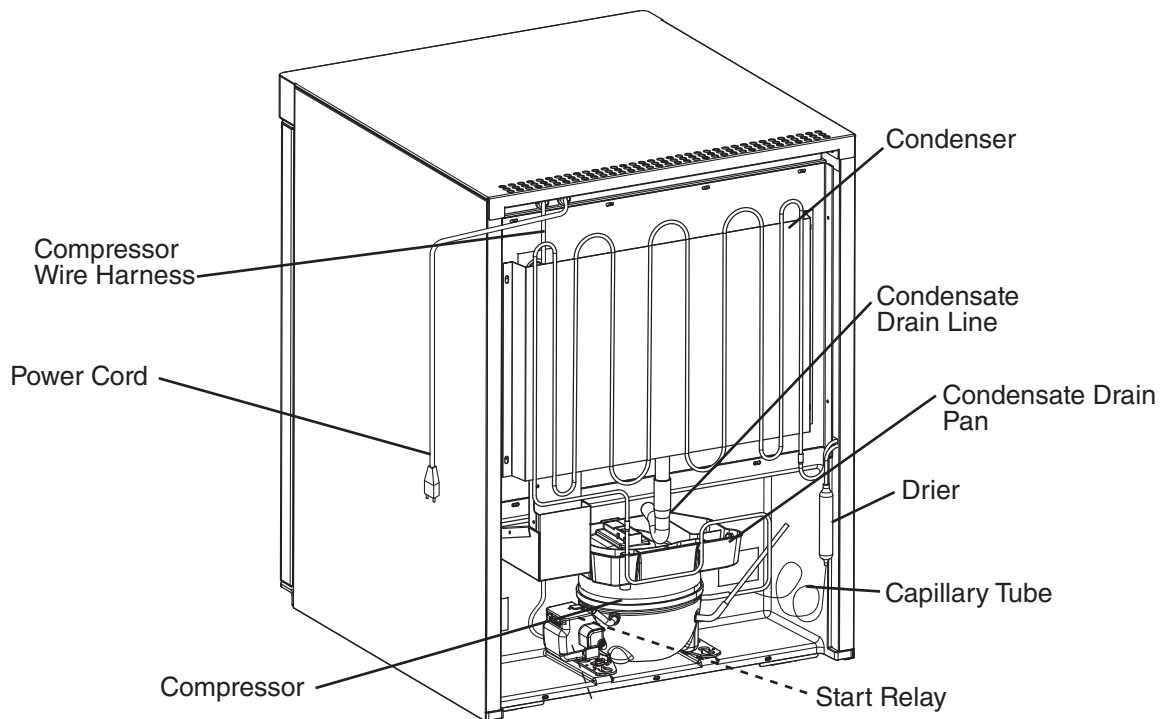
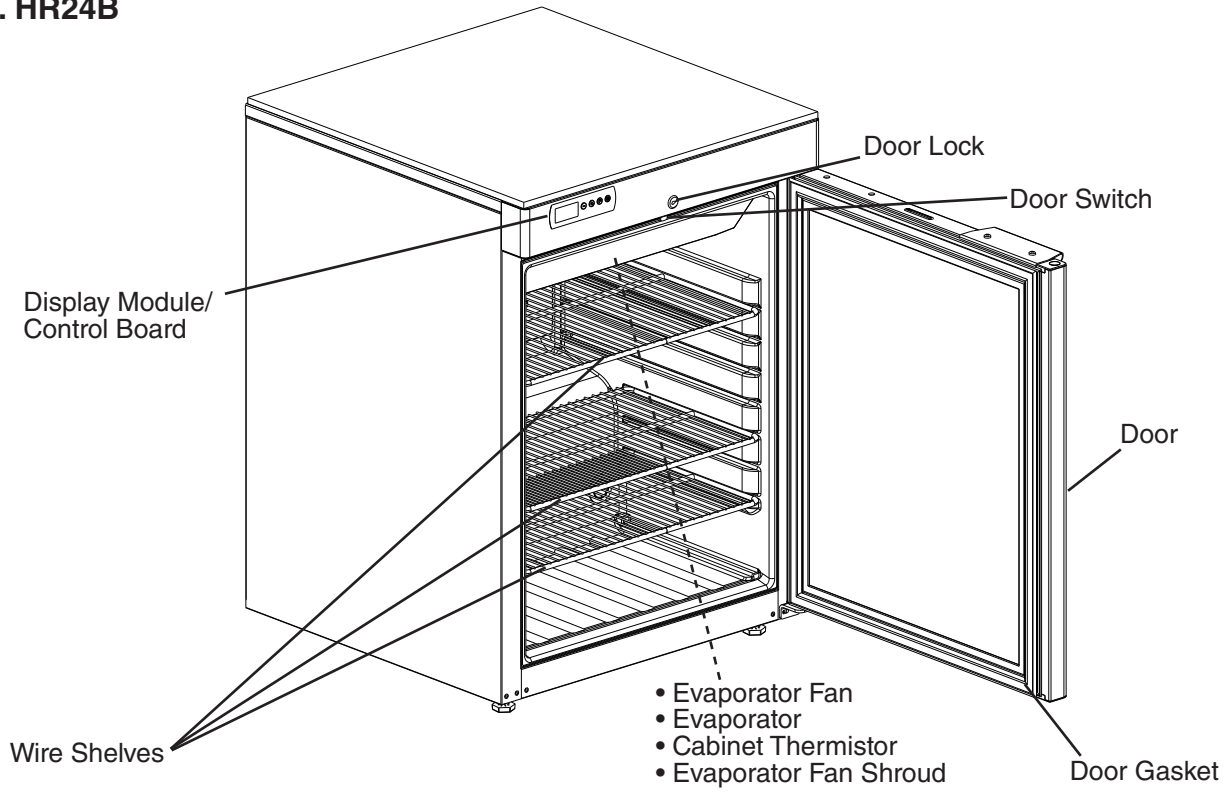

2. Dimensions and Storage Capacity

We reserve the right to make changes in specifications and design without prior notice.

a) Dimensions

Unit: mm [in.]

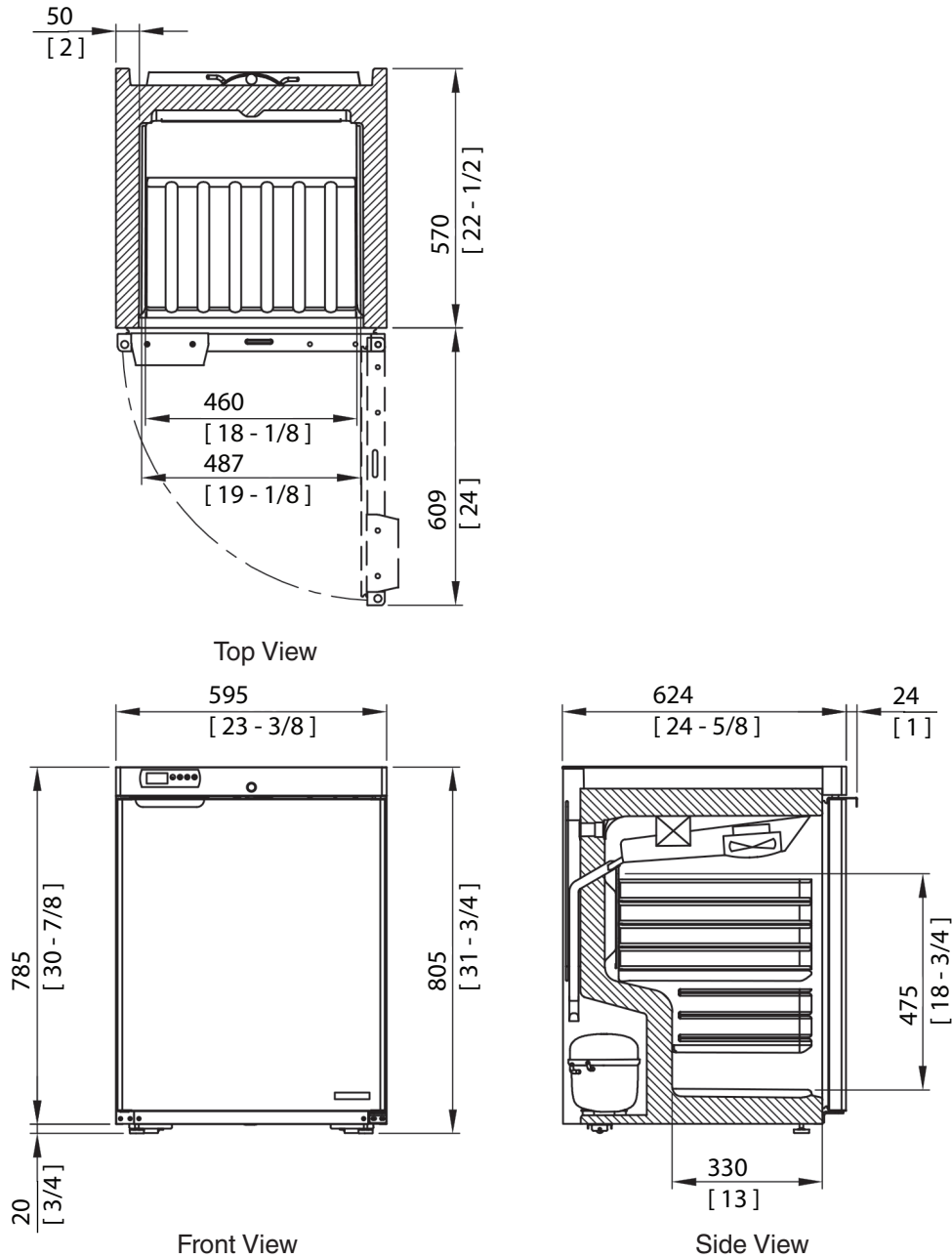

Additional Dimensions (mm [in.])				
Model	Interior Width	Interior Height	Interior Depth	Door Stay Open Position
HR24B	460 [18 1/2]	475 [18 3/4]	450/330 [17 3/4 / 13]	616 [24 1/4]

b) Storage Capacity

Storage Capacity		
Model	Interior Storage Capacity (ft ³)	Total Shelf Space (ft ²)
HR24B	3.67	2.26

B. Refrigeration Circuit

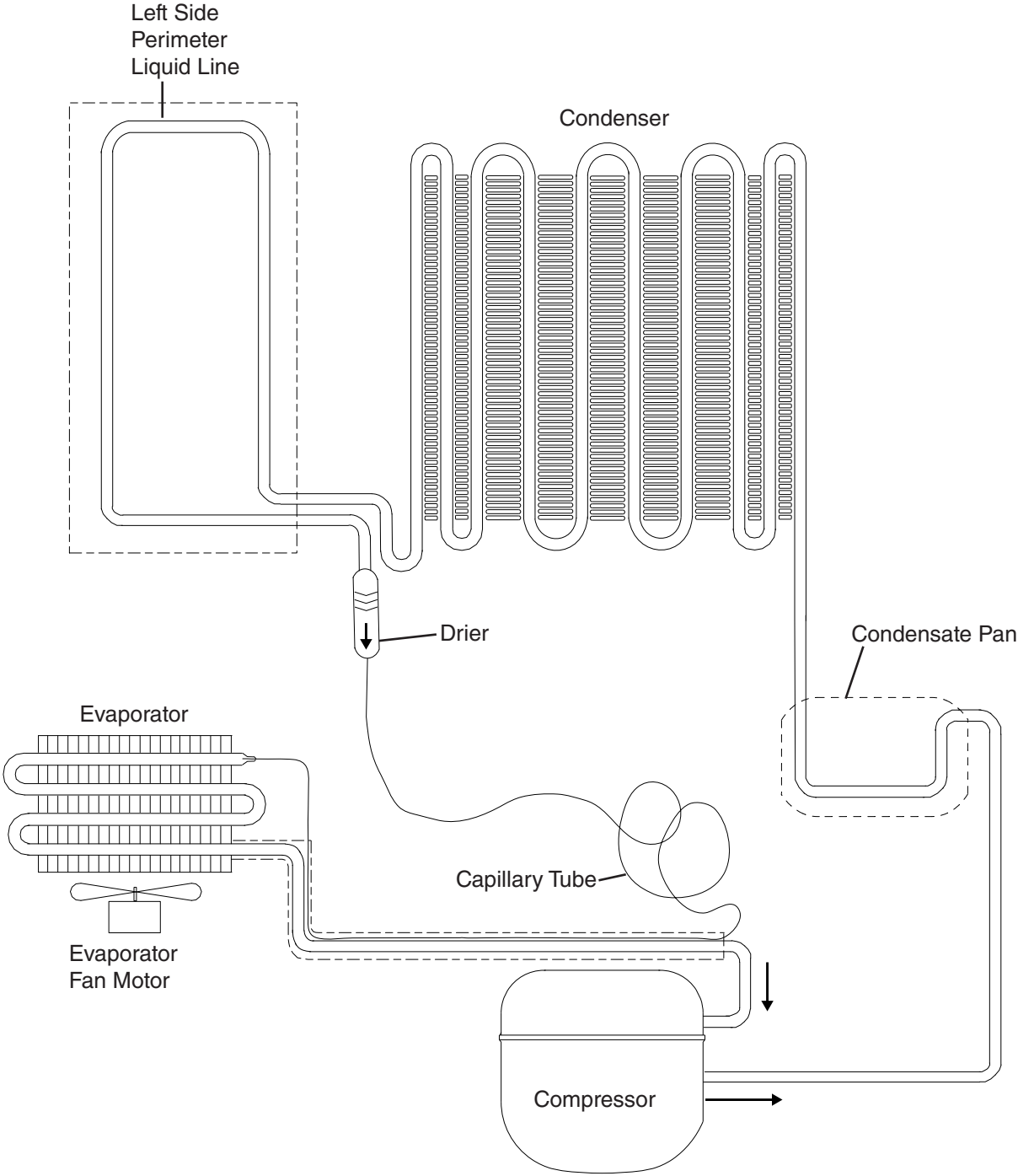

II. Sequence of Operation and Service Diagnosis

A. Sequence of Operation Flow Chart

HR24B Sequence Flow Chart

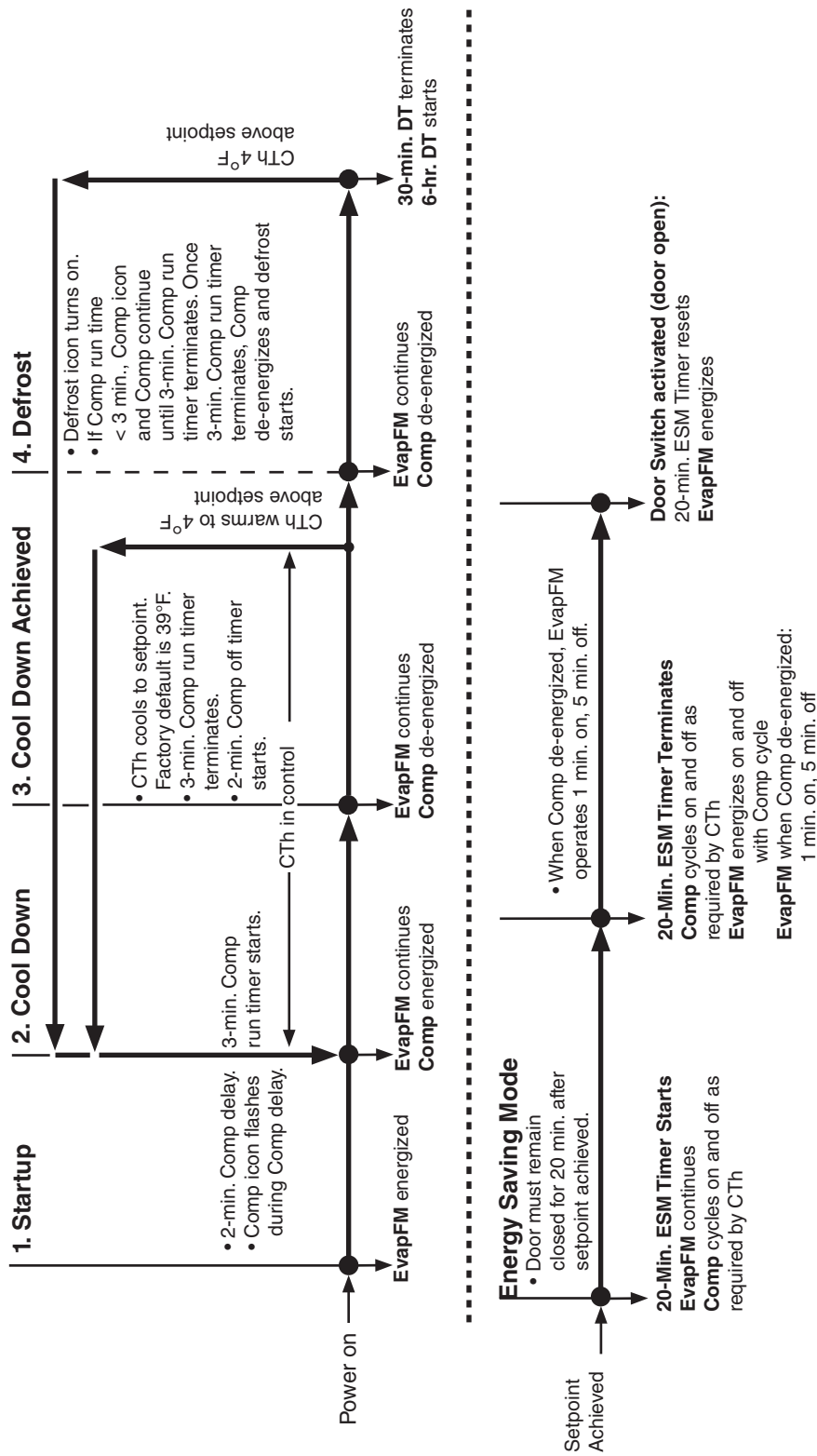

Note:

- EvapFM de-energizes when door is open.
- There is a Comp delay of 2 min. at startup.
- There is a minimum Comp run time of 3 min.
- There is a Comp delay of 2 min. after a power interruption.
- To initiate manual defrost, press and hold the "+" button until the defrost icon turns on the display module.
- Defrost lasts 30 min.

Legend:

- Comp-compressor
- CTh-cabinet thermistor
- ESM-energy saving mode
- EvapFM-evaporator fan motor
- DT-defrost timer

B. Cabinet Temperature and Defrost

1. Default Settings

The default CT setpoint is 39°F. The default CT display scale setting is °F. **NOTICE! Do not change the CT display scale from °F to °C. All temperature related values in the service menu must be changed manually if the CT display scale is changed from °F to °C.**

a) Adjusting the Temperature Setpoint

The CT setpoint is adjustable between 34°F and 52°F. Follow the directions below to adjust the CT setpoint.

Note: If the display module panel is locked, press and hold the "-" button and the power button until "UnL" appears briefly on the display module.

- 1) Press and hold the "P" button until Comp icon flashes on DM.
- 2) Press the "-" or "+" button until the desired value is displayed.
- 3) Press the "P" button to save the new CT setpoint and return to the CT display. If no button is pressed for 15 sec. after selecting the new CT setpoint, DM returns to CT display and the new CT setpoint is saved.

b) Manual Defrost



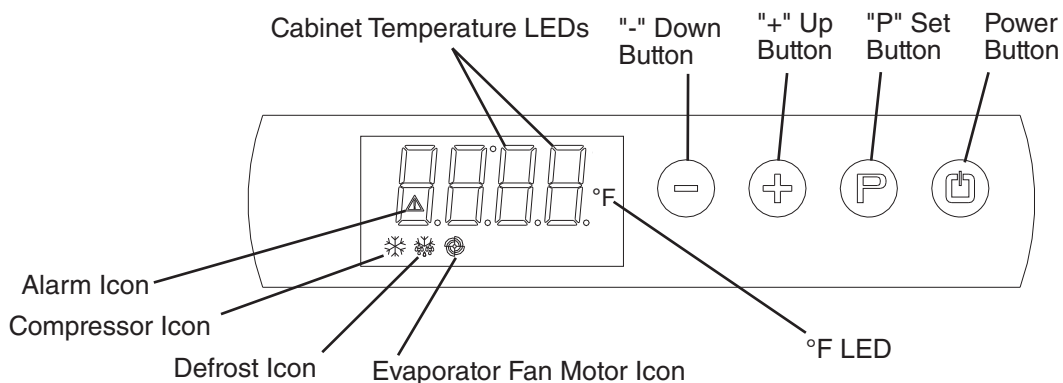

To initiate a manual defrost, press and hold the "+" button until the defrost icon turns on. 30-min. DT starts. If Comp run time < 3 min., Comp icon and Comp continue until 3-min. Comp run timer terminates. Once 3-min. Comp run timer terminates, Comp icon turns off, Comp de-energizes, and 30-min. DT starts. During defrost, the defrost icon stays on, EvapFM runs normally, and CT is displayed. Defrost lasts for 30 min.

Legend: **Comp**—compressor; **CT**—cabinet temperature; **DM**—display module; **DT**—defrost timer; **EvapFM**—evaporator fan motor



C. Display Module Icons

Display module icons inform you of energized components and if the appliance is in alarm.

Display Module Icons	
Icon	Meaning
	Compressor Steady: Compressor running. Flashing: • Compressor delay timer. Compressor starts within 2 min. • While adjusting cabinet temperature setpoint. For cabinet temperature setpoint adjustment, see "II.B Cabinet Temperature and Defrost."
	Defrost Appliance is in defrost cycle. See "II.F.3.10) Defrost" for details.
	Evaporator Fan Motor Evaporator fan motor is running. Evaporator fan motor de-energizes when door is open. During energy saving mode, evaporator fan motor cycles with compressor. When compressor is de-energized, evaporator fan motor cycles 1 min. on and 5 min. off.
	Alarm Appliance is in alarm. See "II.I. Alarm Safeties" for details.

D. Control Panel Lockout

The control panel can be locked to help prevent the appliance from being turned off or the setpoint from being changed inadvertently.

To lock the control panel, press and hold the "-" button and the power button until "Loc" appears briefly on the display module.

To unlock the control panel, press and hold the "-" button and the power button until "UnL" appears briefly on the display module.

E. Service Diagnosis

DANGER

Risk of Fire or Explosion

Flammable Refrigerant Used

- Follow handling instructions carefully in compliance with U.S. government regulations.
- Do not use mechanical devices to defrost.
- Do not puncture refrigerant tubing. Risk of fire or explosion due to puncture of refrigerant tubing; follow handling instructions carefully.
- Component parts shall be replaced with like components.
- Servicing shall be done by factory authorized service personnel to minimize the risk of possible ignition due to incorrect parts or improper service.
- Consult instruction manual/service manual before attempting to install or service this product. All safety precautions must be followed.
- Dispose of properly in accordance with federal or local regulations.
- Do not place any potential ignition sources in or near the appliance.

Risque De Feu Ou D'Explosion

Le Frigorigène Est Inflammable

- Suivre attentivement les instructions de manipulation conformément à la réglementation gouvernementale.
- Ne pas utiliser d'appareils mécaniques pour dégivrer le réfrigérateur.
- Ne pas perforer la tubulure contenant le frigorigène. Risque de feu ou d'explosion si la tubulure contenant le frigorigène est perforée; suivre les instructions de manutention avec soin.
- Les pièces des composants doivent être remplacées par des pièces et accessoires équivalents.
- L'entretien doit être effectué par le personnel de service autorisé par le fabricant afin de minimiser les risques d'inflammation attribuables à l'installation d'une pièce inadéquate ou à la mauvaise exécution du service.
- Consulter le manuel du propriétaire/guide de réparation avant de tenter une réparation. Toutes les mesures de sécurité doivent être respectées.
- Éliminer conformément aux règlements fédéraux ou locaux.
- Ne placez aucune source d'inflammation potentielle dans ou près de l'appareil.

WARNING

- This appliance should be diagnosed and repaired only by qualified service personnel to reduce the risk of death, electric shock, serious injury, or fire.
- Wear appropriate personal protective equipment (PPE) when servicing the appliance.
- Risk of electric shock. Use extreme caution and exercise safe electrical practices.
- Moving parts (e.g. fan blade) can crush and cut. Keep hands clear.
- Appliance is heavy. Use care when lifting or positioning. Work in pairs when needed to prevent injury or damage.
- Make sure all food zones are clean after the appliance is serviced.

The diagnostic procedure is basically a sequence check that allows you to diagnose the electrical system and components. Before proceeding, check for correct installation and proper voltage per appliance nameplate. When checking AC voltage (115VAC), always choose a neutral (W) wire to establish a good neutral connection. If the control board is in alarm, see "II.I Alarm Safeties." For further details, see "II.F.3. Control Board Check."

- If the control panel is locked, press and hold the "-" button and the power button until "UnL" appears briefly on the display module.
 - The °F and cabinet temperature LEDs remain on throughout the sequence of operation.
 - This appliance uses a time-initiated/time-terminated Comp off cycle defrost. The factory default defrost setting is once every 6 hours for 30 min.
 - 6-hr. defrost timer starts the very first time CB is energized (during factory testing). Defrost time is cumulative power on time, therefore time may vary between starting the appliance and the first defrost. After the first defrost, defrost can be monitored for activation every 6 hours.
 - Cabinet temperature is displayed during defrost.
- 1) Press and hold the power button for 2 sec. to turn off the appliance.
 - 2) Unplug the appliance from the electrical outlet.
 - 3) Remove the top panel. Secure the top panel to prevent it from falling over when checking voltages and CB items.
 - 4) Secure (tape) DS in the door closed position.
 - 5) Plug the appliance back into the electrical outlet. °F LED turns on. **Diagnosis:** Confirm that °F LED is on. If not, check CB POWER connector for 115VAC. If 115VAC is not present, check power supply and power cord connection. If 115VAC is present and °F LED is not on, replace CB.
 - 6) Press the power button for 2 sec. to turn on the appliance.
 - 7) **Startup–EvapFM icon is on and Comp icon is flashing.** EvapFM energizes. 2-min. Comp delay timer starts. Comp icon flashes until 2-min. Comp delay timer terminates. **Diagnosis:** Check that CT LEDs and EvapFM icon turn on. Next, check that EvapFM energizes. If not, confirm that DS is engaged (pushed in). Check across DS orange (O) wires for 0VDC. If 0VDC is not present, check DS activation lever and DS continuity. Note: DS orange (O) wires circuit contacts are closed when DS is engaged. If 0VDC is present, check CB EvapFM connector for 12VDC. If 12VDC is not present, replace CB. If 12VDC is present, check EvapFM wiring connector for loose connection, EvapFM continuity, and fan blade for binding.
 - 8) **Cool Down–EvapFM icon is on and Comp icon turns steady.** EvapFM continues. 2-min. Comp delay timer terminates. Comp energizes and 3-min. Comp run timer starts. **Diagnosis:** Confirm CTh is at least 4°F above setpoint. Next, check that Comp energizes. If not, check CB Comp connector for 115VAC. If 115VAC is not present, confirm CTh status. See "II.G. Thermistor Check." If CTh is in range and 115VAC is not present, replace CB. If 115VAC is present, and Comp is off, check Comp wire harness connections. Next check Comp external protector (integrated with start relay), Comp start components, and Comp motor winding continuity. If Comp energizes and the cabinet does not cool down, check for air leaks around the door (gasket), a restriction in the refrigeration circuit, or refrigerant leak.

- 9) **Cool Down Achieved–EvapFM icon is on.** CTh cools to setpoint (default 39°F). EvapFM continues. If Comp run time > 3-min., Comp icon turns off and Comp de-energizes. If Comp run time < 3-min., Comp continues until 3-min. Comp run timer terminates, then Comp icon turns off and Comp de-energizes. **Diagnosis:** If CTh is in range and Comp does not de-energize, confirm Comp run time > 3 min. If Comp continues after 3-min. Comp run timer terminates, replace CB.
- 10) **Cool Down Restart–EvapFM icon is on.** CTh warms to 4°F above setpoint (default 39°F). Comp icon turns on and Comp energizes. 3-min. Comp run timer starts. **Diagnosis:** See step 8 above.
- 11) **Defrost–EvapFM and Defrost icons are on. Cabinet Temperature is Displayed.**
- a) *Automatic Defrost Initiation:* 6-hr. DT terminates. 30-min. DT starts. EvapFM continues. If Comp run time < 3 min., Comp icon and Comp continue until 3-min. Comp run timer terminates. Once 3-min. Comp run timer terminates, Comp icon turns off, Comp de-energizes, and defrost starts. **Diagnosis:** Has 6-hr. DT terminated? If defrost icon is on, confirm that Comp de-energizes. If not, confirm Comp run time > 3 min. If Comp continues after 3-min. Comp run timer terminates, replace CB.
- b) *Manual Defrost Initiation:* To initiate a manual defrost, press and hold the "+" button until the defrost icon turns. 30-min. DT starts. EvapFM continues. If Comp run time < 3 min., Comp icon and Comp continue until 3-min. Comp run timer terminates. Once 3-min. Comp run timer terminates, Comp icon turns off, Comp de-energizes, and defrost starts. **Diagnosis:** If defrost icon is on, confirm that Comp de-energizes. If not, confirm Comp run time > 3 min. If Comp continues after 3-min. Comp run timer terminates, replace CB.
- c) *Defrost Termination:* **Comp icon is on. EvapFM icon flashing.** 30-min. DT terminates. 6-hr. DT starts. Comp icon turns on and Comp energizes. 2-min. EvapFM timer starts. EvapFM icon starts flashing and EvapFM de-energizes. When 2-min. EvapFM timer terminates, EvapFM icon turns steady and EvapFM energizes. Normal operation resumes. **Diagnosis:** Has appliance been in defrost for 30 min.? If not, allow 30-min. DT to terminate. Confirm CTh is 4°F above setpoint. After 30-min. DT terminates, does Comp icon turn on and Comp energize? If not, replace CB. If 30-min. DT terminates and Comp icon turns on but Comp does not energize, check CB Comp connector for 115VAC. If 115VAC is not present, replace CB. If 115VAC is present, and Comp is off, check Comp wire harness connections, Comp external protector (integrated with start relay), Comp start components, and Comp motor winding continuity.

12) Energy Saving Mode

ESM initiates during periods of inactivity. Once CTh cools to setpoint, 20-min. ESM timer starts. DS must remain engaged without activation (door open) for 20 min. after CTh has achieved setpoint for ESM to initiate. Once 20-min. ESM timer terminates, EvapFM operates on ESM cycle.

Diagnosis: Confirm 20-min. ESM timer terminates. Check that EvapFM cycles off with Comp and operates 1 min. on and 5 min. off when Comp is de-energized. If not, replace CB.

Legend: **CB**—control board; **Comp**—compressor; **CT**—cabinet temperature; **DM**—display module; **DS**—door switch; **DT**—defrost timer; **ESM**—energy saving mode; **EvapFM**—evaporator fan motor

F. Control Board and Display Module Check

- For factory default settings, see "II.J. Service Menu."
- For control board check procedure, see "II.F.3. Control Board Check."

NOTICE

- The control board and display module are fragile; handle very carefully.
- The control board and display module contain integrated circuits, which are susceptible to failure due to static discharge. It is especially important to touch the metal part of the appliance before handling or replacing the control board and display module .
- Do not touch the electronic devices on the control board and display module or the back of the control board or display module.
- Do not change wiring and connections. Do not misconnect terminals.
- Do not short out power supply to test for voltage.
- Always replace the whole control board and display module assembly if it goes bad.

1. Control Board Layout

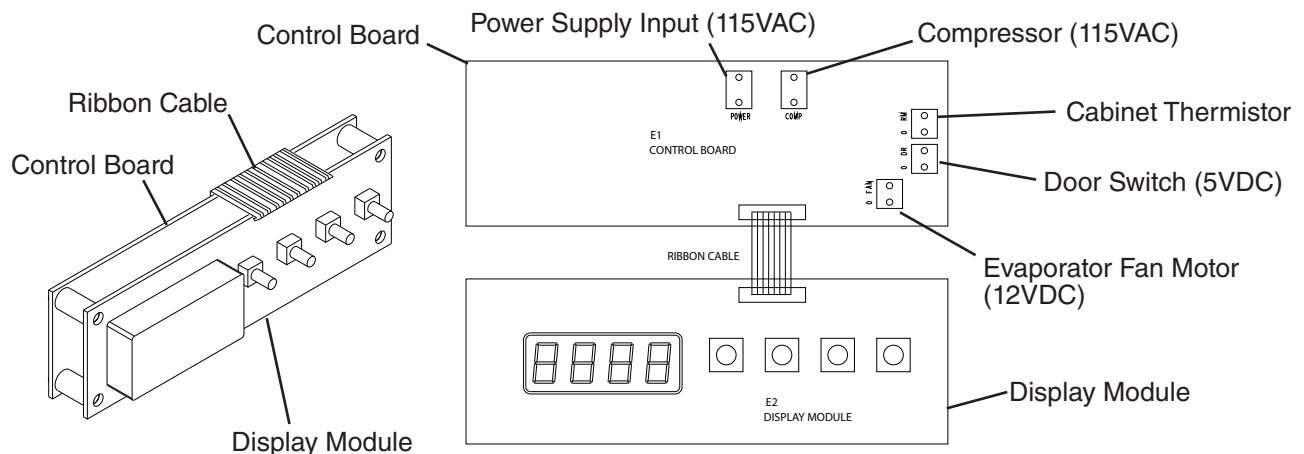

Fig. 1

2. Display Module Layout

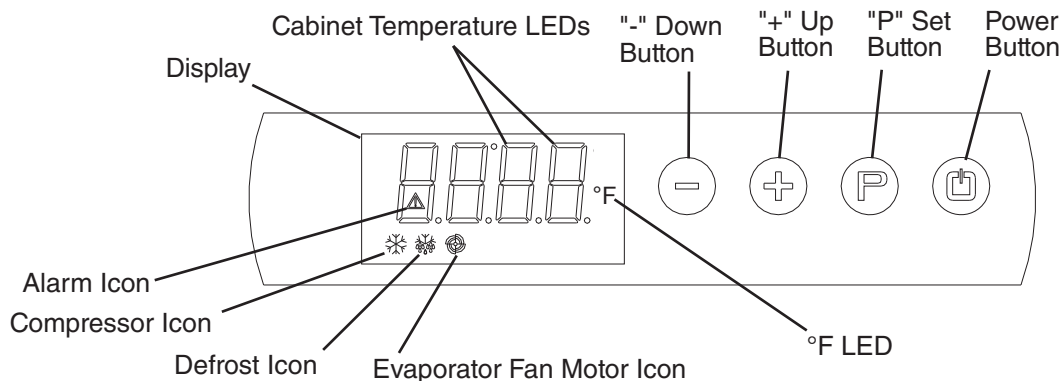

Fig. 2

3. Control Board Check

Before replacing a CB that does not show a visible defect and that you suspect is bad, always conduct the following check procedure. This procedure will help you verify your diagnosis. Always choose a neutral (W wire) to establish a good neutral connection when checking AC voltage (115VAC).

Startup and Cool Down:

- 1) Press the power button for 2 sec. to turn off the appliance.
- 2) Unplug the appliance from the electrical outlet.
- 3) Remove the top panel. Check all wiring connections. Confirm that the power cord, EvapFM, Comp, DS, and CTh are all properly connected to CB and ground connection (GND) is properly connected to the frame.
- 4) Secure the top panel to prevent it from falling over when checking voltages and CB items.
- 5) Secure (tape) DS in the door closed position.
- 6) Plug the appliance back in. °F LED turns on. **Diagnosis:** Confirm that °F LED is on. If not, check CB POWER connector for 115VAC. If 115VAC is not present, check power supply and power cord connection. If 115VAC is present and °F LED is not on, replace CB.
- 7) Press the power button for 2 sec. to turn on the appliance.
- 8) Check that CT LEDs and EvapFM icon turn on. If not, check for 115VAC at the POWER connector on CB. If 115VAC is not present, check power cord and power supply. If 115VAC is present, and DM is not on (°F and CT LEDs and EvapFM icon), replace CB. Confirm control board service menu setting L1 is at 1.
- 9) If °F and CT LEDs are on but EvapFM icon is not, confirm DS is engaged (pushed in). Check across DS orange wires for 0VDC. If 0VDC is not present, check DS activation lever and DS continuity. Note: DS orange (O) wires circuit contacts are closed when DS is engaged. If 0VDC is present, check CB EvapFM connector for 12VDC. If 12VDC is not present, replace CB. If 12VDC is present, check EvapFM wiring connector for loose connection, EvapFM continuity, and fan blade for binding.
- 10) **Defrost:**

This appliance defrosts every 6 hrs. for 30 min. Defrost is an off-cycle defrost.

 - a) *Manual Defrost Initiation:* To initiate a manual defrost, press and hold the "+" button until the defrost icon turns on. 30-min. DT starts. EvapFM continues. If Comp run time < 3 min., Comp icon and Comp continue until 3-min. Comp run timer terminates. Once 3-min. Comp run timer terminates, Comp icon turns off, Comp de-energizes, and 30-min. DT starts. **Diagnosis:** If defrost icon is on, confirm that Comp de-energizes. If not, confirm Comp run time > 3 min. If Comp continues after 3-min. Comp run timer terminates, replace CB.

b) *Defrost Termination: Comp icon is on. EvapFM icon flashing.* 30-min. DT terminates. 6-hr. DT starts. Comp icon turns on and Comp energizes. 2-min. EvapFM timer starts. EvapFM icon starts flashing and EvapFM de-energizes. When 2-min. EvapFM timer terminates, EvapFM icon turns steady and EvapFM energizes. Normal operation resumes. **Diagnosis:** Has appliance been in defrost for 30 min.? If not, allow 30-min. DT to terminate. Confirm CTh is 4°F above setpoint. After 30-min. DT terminates, does Comp icon turns on and Comp energize? If not, replace CB.

Legend: **CB**—control board; **Comp**—compressor; **CT**—cabinet temperature; **DM**—display module; **DS**—door switch; **DT**—defrost timer; **EvapFM**—evaporator fan motor

G. Thermistor Check

The cabinet thermistor is used for cabinet temperature control. Thermistor resistance varies depending on temperature. The control board monitors the resistance to control system operation. No adjustment is required. In the event the cabinet thermistor reading is out of range (Pr1 alarm), the compressor operates on a fixed time basis of 10-min. on and 10-min. off.

To check thermistor resistance, follow the steps below.

- 1) Press the power button for 2 sec. to turn the appliance off, then unplug the appliance.
- 2) Remove the evaporator shroud.
- 3) Disconnect and remove the evaporator thermistor.
- 4) Immerse the thermistor sensor portion in a glass containing ice and water for 2 to 3 min.
- 5) Check the resistance between the wires at the thermistor connector. Normal reading is within 14.0 to 19.0 kΩ. If outside the normal reading, replace the thermistor.
- 6) Reconnect and replace the thermistor in its correct position.
- 7) Replace the evaporator shroud in its correct position.
- 8) Plug the appliance back in. Press the power button for 2 sec. to turn the appliance on.

H. Diagnostic Chart

Before consulting the diagnostic charts, check the following:

- Check the cabinet temperature setpoint and factory default settings. For factory default settings, see "II.B. Cabinet Temperature and Defrost" and "II.J. Service Menu."
- Make sure the doors are not left open or opened too often and that they are sealing properly.
- Make sure product is not blocking airflow and that the cabinet is not overloaded with warm or hot product. Product should be allowed to cool before putting in the appliance.
- Check for correct installation and proper voltage per appliance nameplate. This appliance is approved for indoor or outdoor use. Normal operating ambient temperature should be within 61°F to 95°F (16°C to 35°C).
- The appliance should not be located next to ovens, grills, or other high heat producing equipment or exposed to direct sunlight.
- The appliance must have a minimum of 1" (3 cm) clearance at bottom and top. Air must be able to circulate freely under, behind, and above the appliance.
- Check the control board using the steps in "II.F.3. Control Board Check."

1. Appliance Not Cooling

Appliance Not Cooling - Possible Cause	
1. Power Supply	a) Unplugged, off, blown fuse, or tripped or defective breaker.
	b) Loose connection.
	c) Not within specifications.
2. Cord and Plug	a) Loose connection.
	b) Defective.
3. Wiring	a) Loose connection or open.
	b) Faulty.
4. Power Button (control board)	a) Turned "OFF."
	b) Defective.
5. Control Board and Display Module See "II.J. Alarm Safeties." and "II.F.3. Control Board Check."	a) In alarm.
	b) Defective.
6. Door Switch	a) Door open.
	b) Defective.
	c) Control board service menu setting L1 not set to 1.
7. Evaporator Fan Motor	a) Fan blade binding.
	b) Defective.
8. Compressor	a) Compressor external protector open or defective.
	b) Motor winding open.
	c) PTC relay contacts bad or coil winding open.
	d) Inefficient.
9. Condenser	a) Dirty.
10. Evaporator	a) Dirty or frozen up.
11. Refrigerant/Refrigerant Lines	a) Gas leak, low charge.
	b) Refrigerant lines restricted.



2. Evaporator is Frozen Up

Evaporator is Frozen Up - Possible Cause	
1. Evaporator	a) Dirty.
2. Evaporator Fan Motor	a) Defective.
3. Control Board	a) Defective, not operating evaporator fan motor.
4. Refrigerant/Refrigerant Lines	a) Gas leak, low charge.
	b) Refrigerant lines restricted.

3. Defrost Fails to Start or Terminate

Defrost Fails to Start or Terminate - Possible Cause	
1. Control Board	a) Defective.

I. Alarm Safeties

The alarms are designed to protect the appliance and the items inside. These alarms give information and warnings in the event the appliance is operating out of acceptable parameters. For all alarms except Pr1, the alarm icon  turns on and the alarm code alternates with the cabinet temperature. If the Pr1 alarm occurs, only Pr1 and the alarm icon  are displayed.

Alarm Signals		
Alarm Code	Problem	Corrective Action/Reset Details
AH	High Temperature Alarm Cabinet temperature has exceeded the setpoint temperature by 10°F for more than 2 hours.	If obvious corrections such as closing the door and cleaning the condenser do not bring temperature back in range, see "II.E. Service Diagnosis." Automatically resets when temperature returns to normal. Alarm icon flashes until reset manually.
AL	Low Temperature Alarm Cabinet temperature has remained below the setpoint temperature by 10°F for more than 2 hours.	If obvious corrections do not bring the temperature back in range, see "II.E. Service Diagnosis." Automatically resets when temperature returns to normal. Alarm icon flashes until reset manually.
Ld	Door Open	Close the door.
Pr1	Cabinet Thermistor Malfunction Alarm Cabinet thermistor has failed.	Compressor and evaporator fan motor cycle 10 min. on, 10 min. off.

a) High and Low Temperature Alarm Values (AH or AL)

If an AH or AL alarm occurs, follow the steps below to acquire alarm details.

- 1) Press the "-" button for 3 sec. to enter the alarm menu. "EnS" is displayed.
- 2) Press the "+" button once. "LS" is displayed.
- 3) Press the "P" button. The alarm code is displayed.
- 4) Press the "P" button again and the alarm details are displayed in 2 second increments.

AH or AL Alarm code

XX°F The highest or lowest temperature during the alarm

dur Alarm duration

h01 Hours alarm has been engaged

n15 Minutes alarm has been engaged (continuance of h01)

To review, press the "P" button again.

To exit, press the on/off button twice. After pressing the on/off button the first time, "LS" is displayed. After pressing the on/off button the second time, the display returns to the alarm code display.

b) Clearing High and Low Temperature Alarms

To clear an alarm, follow the steps below.

- 1) Press the "-" button for 3 sec. to enter the alarm menu. "EnS" is displayed.
- 2) Press the "-" or "+" button twice. After pressing the "-" or "+" button the first time, "LS" is displayed. After pressing the "-" or "+" button the second time, "rLS" is displayed.
- 3) Once "rLS" is displayed, press the "P" button.
- 4) Using the "-" or "+" button, set the display to "149."
- 5) Press the "P" button. The display flashes "----" for 4 sec. The alarm and display module are now deleted and clear. The control board returns to normal operation.

Note: If the cabinet temperature is out of acceptable range, the procedures above only change the alarm icon  from flashing to steady for 15 minutes. Once the temperature is in acceptable range, the alarm clears from the display module and deleted from memory.

J. Service Menu

The service menu chart is provided to give information on the operation parameters of this appliance. **NOTICE! Do not adjust. Adjustments outside of the factory default settings could adversely affect safety, performance, component life, and warranty coverage.**

Note: If the display module panel is locked, press and hold the "-" button and the power button until "UnL" appears briefly on the display module.

a) Service Menu Access

(1) Enter Service Menu

1. Make sure the appliance is plugged into the electrical outlet and power is on.
2. Press and hold the "-" and "+" buttons until "PA" is displayed.
3. Press the "P" button. "0" is displayed. Using the "-" button, set the display to "-19." This is the service menu password.

(2) Service Menu List

4. Press the "P" button, "PA" is displayed. Press and hold the "-" and "+" buttons until "SP" is displayed. "SP" is the first level of the service menu. "SP" is working setpoint.
5. To view the setting value, press the "P" button. To adjust the setting value, press the "-" or "+" button. To return to the service menu list, press the "P" button. This saves the new value and returns you to the service menu list.
6. Press the "-" or "+" button to scroll through the service menu list. Press the "P" button to view the selected setting value. Press the "P" button again to save the changes and return to the service menu list.

(3) Exit Service Menu

7. Press the "-" and "+" buttons for 4 sec. to exit the service menu or do not operate the display for 60 sec. Display automatically switches back to normal operating mode and saves changes after 60 sec. of inactivity.

b) Service Menu Chart

Setpoint					
Service Menu	Min.	Max.	Unit	Factory Setting	Description
SP	See r1	See r2	°C/°F	39°F	Cabinet setpoint. (compressor off temperature). (see r0 for compressor on temperature).

Thermistor Input (Do Not Adjust)					
Service Menu	Min.	Max.	Unit	Factory Setting	Description
CA1	-25	25	°C/°F	0	Cabinet thermistor temperature offset.
CA2	-25	25	°C/°F	0	Evaporator thermistor temperature offset.
P1	0	1	---	0	Decimal point for °C display: 0=no, 1=yes.
P2	0	1	---	1	Temperature display scale: 0=°C, 1=°F
P3	0	2	---	0	Evaporator thermistor: 0=not connected 1=defrost/evaporator fan 2=defrost
P8	0	250	ds	5	Temperature display delay.

Operation (Do Not Adjust)					
Service Menu	Min.	Max.	Unit	Factory Setting	Description
r0	0	15	°C/°F	4°F	Temperature differential above setpoint for the compressor to turn on.
r1	-99	r2	°C/°F	34°F	Minimum cabinet setpoint.
r2	r1	99	°C/°F	52°F	Maximum cabinet setpoint.
r3	0	1	---	0	Locked setpoint. 0=no, 1=yes
r4	0	99	°C/°F	0	Energy saving and overcooling Do not adjust.
r5	0	99	°C/°F	0	
r6	0	240	min.	30	

Compressor Protection (Do Not Adjust)					
Service Menu	Min.	Max.	Unit	Factory Setting	Description
C0	0	240	min.	2	Compressor delay at startup and after power interruption.
C1	0	240	min.	5	Minimum time between compressor starts.
C2	0	240	min.	3	Minimum compressor off time.
C3	0	240	sec.	180	Minimum compressor run time.
C4	0	240	min.	10	Compressor off time with defective cabinet thermistor.
C5	0	240	min.	10	Compressor on time with defective cabinet thermistor.

Defrost (Do Not Adjust)					
Service Menu	Min.	Max.	Unit	Factory Setting	Description
d0	0	99	hrs.	6	Defrost interval: 0=no defrost
d1	0	2	---	2	Defrost type. Do not adjust. 0=electric heater 1=hot gas 2=off cycle (evaporator fan motor)
d2	-99	99	°C/°F	N/A	Limit for defrost if P3 = 1 or 2.
d3	0	99	min.	30	Defrost duration.
d4	0	1	---	0	Defrost on startup. Do not adjust. 0=no, 1=yes
d5	0	99	min.	0	Minimum time between startup and defrost. Do not adjust.
d6	0	1	---	0	Temperature display during defrost. Do not adjust. 0=cabinet temperature 1=cabinet temperature or setpoint + differential (4°F). Based on cabinet temperature at defrost initiation.
d7	0	15	min.	0	Drip time. Do not adjust.
d8	0	3	---	0	Defrost initiation. Do not adjust. 0=d0 defrost timer is cumulative power on time. 1=d0 defrost timer is cumulative compressor run time. 2=defrost starts when evaporator temperature < d9 for time d0. 3=based on evaporator temperature when evaporator thermistor is present.
d9	-99	99	°C/°F	32	Do not adjust.
d10	0	99	°C/°F	27	Do not adjust.
d11	0	1	---	0	Do not adjust.
d12	0	99	min.	30	Do not adjust.
d13	1	240	min.	1	Do not adjust.
d14	0	240	min.	30	Do not adjust.
d15	0	99	min.	0	Minimum compressor run time before defrost if d1=1. Do not adjust.

Temperature Alarm (Do Not Adjust)					
Service Menu	Min.	Max.	Unit	Factory Setting	Description
A0	0	1	---	0	AL alarm sensor. Do not adjust. 0=cabinet thermistor 1=evaporator thermistor
A1	-99	99	°C/°F	-10	Degrees below setpoint for AL alarm when A2=1. Do not adjust.
A2	0	2	---	1	AL alarm. Do not adjust. 0=deactivated 1=A1 relative to setpoint (setpoint - A1) 2=absolute. AL occurs at temperature A1.
A4	-99	99	°C/°F	10	Degrees above setpoint for AH alarm when A5=1. Do not adjust.
A5	0	2	---	1	AH alarm. Do not adjust. 0=deactivated 1=A4 relative to setpoint (setpoint + A4) 2=absolute. AH occurs at temperature A4.
A6	0	240	min.	120	AH delay after startup. Do not adjust.
A7	0	240	min.	120	Delay for AL or AH alarm to occur after temperature is below A1 or above A4. Do not adjust.
A8	0	240	min.	15	AH delay after door switch closes. Do not adjust.
A9	0	240	min.	15	AH delay after door switch opens. Do not adjust.
A11	0.1	15	°C/°F	4	A1 and A4 temperature differential. Do not adjust.

Evaporator Fan Motor (Do Not Adjust)					
Service Menu	Min.	Max.	Unit	Factory Setting	Description
F0	0	4	---	1	Fan operation with door closed. Do not adjust. 0=off 1=on: see also F13, F14, and L10 2=parallel with compressor 3= dependent on F1 4=disabled when compressor is off, dependent on F1 when compressor is on.
F1	-99	99	°C/°F	30	Fan off temperature when F0 set to 3 or 4. Do not adjust.
F2	0	2	---	1	Fan operation during defrost: Do not adjust. 0=disabled 1=enabled 2=dependent on F0
F3	0	15		2	Maximum fan off time when defrost thermistor used.
F7	-99	99	°C/°F	0	Fan on temperature when defrost thermistor used.
F8	0.1	15	°C/°F	4	F1 differential.
F9	0	240	sec.	0	Energy saving evaporator fan motor delay after compressor shuts off.
F13	0	240	min.	5	Energy saving evaporator fan motor off time.
F14	0	240	min.	1	Energy saving evaporator fan motor on time.

Door Switch and Door Alarm (Do Not Adjust)					
Service Menu	Min.	Max.	Unit	Factory Setting	Description
L0	0	5	---	2	Door switch function. 1=compressor and evaporator fan motor de-energized 2=evaporator fan motor de-energized 3-5=reserved
L1	0	1	---	1	Door switch operation. 0=normally open 1=normally closed
L2	-1	120	min.	10	Door alarm time delay. -1=deactivated
L3	-1	120	min.	-1	Evaporator fan motor off time when door is open. -1=until door switch engaged
L4	0	1	---	0	Save door alarm. 0=no 1=yes
L10	0	999	min.	20	Energy saving activation. After cabinet temperature is reached and door switch remains closed.

Serial Network (Do Not Adjust)					
Service Menu	Min.	Max.	Unit	Factory Setting	Description
LA	1	247	---	247	Address (not used)
Lb	0	3	---	2	Baud Rate (not used)
LP	0	2	---	2	Parity (not used)

III. Refrigeration Circuit and Component Service Information

DANGER

Risk of Fire or Explosion Flammable Refrigerant Used

- Follow handling instructions carefully in compliance with U.S. government regulations.
- Do not use mechanical devices to defrost.
- Do not puncture refrigerant tubing. Risk of fire or explosion due to puncture of refrigerant tubing; follow handling instructions carefully.
- Component parts shall be replaced with like components.
- Servicing shall be done by factory authorized service personnel to minimize the risk of possible ignition due to incorrect parts or improper service.
- Consult instruction manual/service manual before attempting to install or service this product.
- Dispose of properly in accordance with federal or local regulations.
- Do not place any potential ignition sources in or near the appliance.

Risque De Feu Ou D'Explosion Le Frigorigène Est Inflammable

- Suivre attentivement les instructions de manipulation conformément à la réglementation gouvernementale.
- Ne pas utiliser d'appareils mécaniques pour dégivrer le réfrigérateur.
- Ne pas perforer la tubulure contenant le frigorigène. Risque de feu ou d'explosion si la tubulure contenant le frigorigène est perforée; suivre les instructions de manutention avec soin.
- Les pièces des composants doivent être remplacées par des pièces et accessoires équivalents.
- L'entretien doit être effectué par le personnel de service autorisé par le fabricant afin de minimiser les risques d'inflammation attribuables à l'installation d'une pièce inadéquate ou à la mauvaise exécution du service.
- Consulter le manuel du propriétaire/guide de réparation avant de tenter une réparation. Toutes les mesures de sécurité doivent être respectées.
- Éliminer conformément aux règlements fédéraux ou locaux.
- Ne placez aucune source d'inflammation potentielle dans ou près de l'appareil.

⚠ WARNING

- Wear appropriate personal protective equipment (PPE) when servicing the appliance.
- Technician must utilize a combustible gas leak detector at all times.
- Notify everyone in the immediate area that you are working with flammable refrigerant.
- Do not work on appliance in a confined space. Confirm area is well ventilated.
- Identify and eliminate all possible ignition points in a 10 ft. (3 m) area around service area.
- Do not use mechanical devices to defrost.
- Use non-sparking tools.
- Class B dry chemical fire extinguisher or equivalent must be available.
- Do not pressurize system above 200 PSIG during leak check procedure or prior to evacuating refrigeration system.
- This appliance should be diagnosed and repaired only by qualified service personnel to reduce the risk of death, electric shock, serious injury, or fire.
- To reduce the risk of electric shock, do not touch the plug with damp hands.
- Unplug the appliance from the electrical outlet before servicing.
- Make sure all food zones in the appliance are clean after the appliance is serviced.

A. Refrigeration Circuit Service Information

⚠ WARNING

- Repairs requiring the refrigeration circuit to be opened must be performed by properly trained and EPA-certified service personnel.
- Use an electronic leak detector or soap bubbles to check for leaks. Add a trace of refrigerant to the system (if using an electronic leak detector), and then raise the pressure using nitrogen gas (140 PSIG). Do not use R-290 as a mixture with pressurized air for leak testing.

⚠ WARNING

- Repairs requiring the refrigeration circuit to be opened must be performed by properly trained and EPA-certified service personnel.
- Use an electronic leak detector or soap bubbles to check for leaks. Add a trace of refrigerant to the system (if using an electronic leak detector), and then raise the pressure using nitrogen gas (140 PSIG). Do not use R-600a as a mixture with pressurized air for leak testing.

NOTICE

- Repairs requiring the refrigeration circuit to be opened must be performed by properly trained and EPA-certified service personnel.
- Use an electronic leak detector or soap bubbles to check for leaks. Add a trace of refrigerant to the system (if using an electronic leak detector), and then raise the pressure using nitrogen gas (140 PSIG). Do not use R-600a as a mixture with pressurized air for leak testing.

Refrigerant leaks must be repaired as soon as they are discovered. If not, refrigerant charge should be recovered from the system until the leak can be repaired.

When repairing a leak:

- Repair the leak properly – Remove the refrigerant, examine the leak source, determine the reason for the leak, and carry out the proper course of action.
- Before repairing the leak, ensure that the refrigerant has been recovered and the system purged with nitrogen when brazing.
- Be sure to remove piercing valves attached to the system after repairs are made.

1. Refrigerant Recovery

Using proper refrigerant practices, place piercing valves toward the end (crimped area) of the high and low-side process tubes, then recover the refrigerant into an approved container or device.

2. Brazing

⚠ DANGER

Risk of Fire or Explosion Flammable Refrigerant Used

- Servicing shall be done by factory authorized service personnel to minimize the risk of possible ignition due to incorrect parts or improper service.

Risque De Feu Ou D'Explosion Le Frigorigène Est Inflammable

- L'entretien doit être effectué par le personnel de service autorisé par le fabricant afin de minimiser les risques d'inflammation attribuables à l'installation d'une pièce inadéquate ou à la mauvaise exécution du service.

⚠ WARNING

- Wear appropriate personal protective equipment (PPE) when servicing the appliance.
- You must have a combustible gas leak detector in the immediate work area at all times.
- You must have a Class B chemical fire extinguisher available at all times.
- Notify all persons in the immediate area that you are working with a flammable refrigerant.
- Do not use silver alloy or copper alloy containing arsenic.
- Be sure the area is clear of refrigerant vapor before brazing.

- 1) Braze/repair/replace damaged component or fitting.
- 2) Purge with nitrogen gas for 2 min. Then braze all fittings while purging with nitrogen gas flowing at a pressure of 3 to 5 PSIG.

NOTICE

- Always install a new drier every time the sealed refrigeration system is opened.
- Do not replace the drier until after all other repair or replacement has been made. Install the new drier with the arrow on the drier in the direction of the refrigerant flow.
- When brazing, protect the drier by using a wet cloth to prevent the drier from overheating. Do not allow the drier to exceed 250°F (121°C).

- 3) Use soap bubbles to check for leaks. Raise the pressure using nitrogen gas (190 PSIG). Do not use any refrigerant as a mixture with pressurized air for leak testing.
- 4) Once leak checking is complete, release the nitrogen gas from the system.

3. Evacuation

- 1) Attach a vacuum pump to the system. Be sure to connect the charging hoses to both high and low-side refrigerant piercing valves.

<i>IMPORTANT</i>

The vacuum level and vacuum pump may be the same as those for current refrigerants. However, the rubber hose and gauge manifold to be used for evacuation and refrigerant charge should be exclusively for POE oils.
--

- 2) Turn on the vacuum pump, then open the gauge manifold valves. Never allow the oil in the vacuum pump to flow backwards.
- 3) Allow the vacuum pump to pull down to a 29.9" Hg vacuum (500 microns). Evacuating period depends on pump capacity.
- 4) Close the low-side valve and high-side valve on the gauge manifold.
- 5) Disconnect the gauge manifold hose from the vacuum pump and attach it to a refrigerant service cylinder. Remember to loosen the connection and purge the air from the hose. For the required refrigerant charge, see the nameplate. Hoshizaki recommends only virgin or reclaimed refrigerant which meets ARI Standard 700 (latest edition) be used.

4. Recharge

- 6) R-600a can be charged in either the liquid or vapor state.
Liquid charge is preferred. If refrigerant charging is done in the liquid state, place the service cylinder on the scales; **if the service cylinder is not equipped with a dip tube, invert the service cylinder, then place it on the scales.** Open the high-side valve on the gauge manifold.
- 7) Allow the system to charge with liquid until the proper charge weight is met.
- 8) Close the high-side valve on the gauge manifold. If charging is complete, skip to step 10.
- 9) If necessary, add any remaining charge to the system through the low-side.
NOTICE! To prevent compressor damage, use a throttling valve or liquid dispensing device to add the remaining liquid charge through the low-side refrigerant access valve with the compressor running. Close the refrigerant cylinder valve and let the low-side refrigerant equalize to the system, then close the low-side manifold gauge. Move the power switch to the "OFF" position (if applicable) or unplug the appliance from the electrical outlet.
- 10) Pinch off (crimp down) the process tubes just below the piercing valves.
- 11) Remove the piercing valves. Cut the process tubes to remove the piercing valve holes then braze the process tubes closed. Note: Be sure there is no refrigerant leak before brazing.
- 12) Use a combustible gas leak detector or soap bubbles to check for leaks again.
- 13) Place red sleeves over the process tubes.
- 14) Plug the appliance back into the electrical outlet.

B. Component Service Information

NOTICE

When replacing a component listed below, see the notes to help ensure proper operation.

Component	Notes
Compressor	Install a new PTC relay. WARNING! To reduce the risk of electric shock, be sure to reconnect the component's ground wire.

C. Door Reversal

If you would like to reverse the door swing, follow the steps below.

- 1) Make sure the appliance is off and unplugged.
- 2) Remove the fasteners securing the top panel. See Fig. 3. Being careful not to pull on the wires to the control panel and door switch, lift off the top panel. Secure the top panel so that it does not interfere with the upper hinge or top panel bracket and will not fall.
- 3) While maintaining a hold on the door, remove the fasteners securing the upper hinge to the right side of the appliance. Lift off the door and upper hinge.
- 4) Remove the top panel bracket from the left side of the appliance, then secure it to the right side of the appliance.
- 5) Remove the 2 outside plastic plugs from the lower left side of the appliance.
- 6) Remove the lower hinge from the right side of the appliance, then secure it to the left side of the appliance.
- 7) Place the 2 plastic plugs in the holes on the lower-right side of the appliance.
- 8) Remove the plastic plugs and the handle from the door.
- 9) Secure the handle to the right side of the door. Place the plugs in the open handle holes on the left side of the door and in the hinge hole on the right side of the door.
- 10) Place the door onto the lower hinge, then place the upper hinge in the door and secure to the left side of the appliance.
- 11) Make sure the door is level. If not, adjust the door using the slots in the hinges.
- 12) Check that the wiring is connected and routed properly, then replace the top panel in its correct position. Secure the top panel.

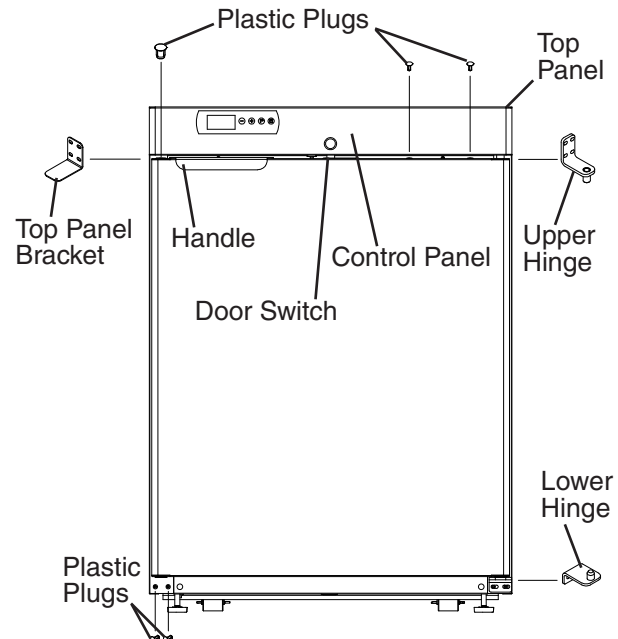

Fig. 3

IV. Cleaning and Maintenance Instructions

A. Cleaning

⚠ WARNING

- Before cleaning the appliance, turn off and unplug the appliance to prevent electric shock by unexpected entrance of water into the appliance or injury by moving parts.
- Before cleaning the appliance, move all items into another refrigerator.
- Do not splash water directly onto the appliance. This might cause short circuit, electric shock, corrosion, or failure.
- Before using a sanitizer such as inert soap and sodium hypochlorite (chlorine bleach), thoroughly read the manufacturer's instructions on its proper usage.

IMPORTANT

- To prevent damage to the plastic surfaces, do not use the following: thinner, benzene, alcohol, petroleum, soap powder, polishing powder, alkaline cleaner, acid, scouring pad and especially those strong cleaners for use on a ventilating fan or a cooking range. Also, to prevent corrosion, do not use sodium hypochlorite (chlorine bleach) on the stainless steel surfaces.
- Use a clean cloth for cleaning.

1. Exterior

Wipe the exterior occasionally with a clean, soft cloth. Use a damp cloth containing a neutral cleaner to wipe off oil or dirt buildup.

2. Cabinet Interior

Spills should be wiped up promptly to avoid unpleasant odors. The cabinet interior should be cleaned periodically with a mild soap or detergent and warm water.

3. Door Gasket

Door gasket should be cleaned regularly with mild soap and warm water to remove dirt and grease.

4. Shelves

Remove and clean regularly.

B. Maintenance

1. Condenser

Check the condenser once a year and use a brush or vacuum cleaner to clean the condenser as required.

2. Power Supply Connection

If the plug or power cord is damaged, replace it. Be sure to connect the ground wire.

V. Preparing the Appliance for Periods of Non-Use

When shutting down the appliance for more than one week, follow the instructions below.

⚠ WARNING

Prevent the doors from closing to reduce the risk of children getting trapped.
--

<i>IMPORTANT</i>

Clean the cabinet interior, door gaskets, and shelves.
--

- 1) Before shutting down the appliance, move all items into another refrigerator.
- 2) Press and hold the power button for 2 sec. to turn off the appliance.
- 3) Unplug the appliance. **WARNING! To reduce the risk of electric shock, do not touch the plug with damp hands.**

VI. Disposal

⚠ DANGER

Risk of Fire or Explosion Flammable Refrigerant Used

- Follow handling instructions carefully in compliance with U.S. government regulations.
- Do not puncture refrigerant tubing. Risk of fire or explosion due to puncture of refrigerant tubing; follow handling instructions carefully.
- Dispose of properly in accordance with federal or local regulations.

Risque De Feu Ou D'Explosion Le Frigorigène Est Inflammable

- Suivre attentivement les instructions de manipulation conformément à la réglementation gouvernementale.
- Ne pas perforer la tubulure contenant le frigorigène. Risque de feu ou d'explosion si la tubulure contenant le frigorigène est perforée; suivre les instructions de manutention avec soin.
- Éliminer conformément aux règlements fédéraux ou locaux.

This appliance contains refrigerant and must be disposed of in accordance with applicable national, state, and local codes and regulations. Refrigerant must be recovered by properly certified service personnel.

VII. Technical Information

We reserve the right to make changes in specifications and design without prior notice.

A. Electrical and Refrigerant Data

See the nameplate for electrical and refrigerant data. The nameplate is located inside the cabinet.

Electrical and Refrigerant Data					
Model	AC Supply Voltage	Amperes	Design Pressure (PSIG)		Refrigerant (oz.)
			HIGH	LOW	R-600a
HR24B	115/60/1	4	360	120	2.80

B. Wiring Diagram

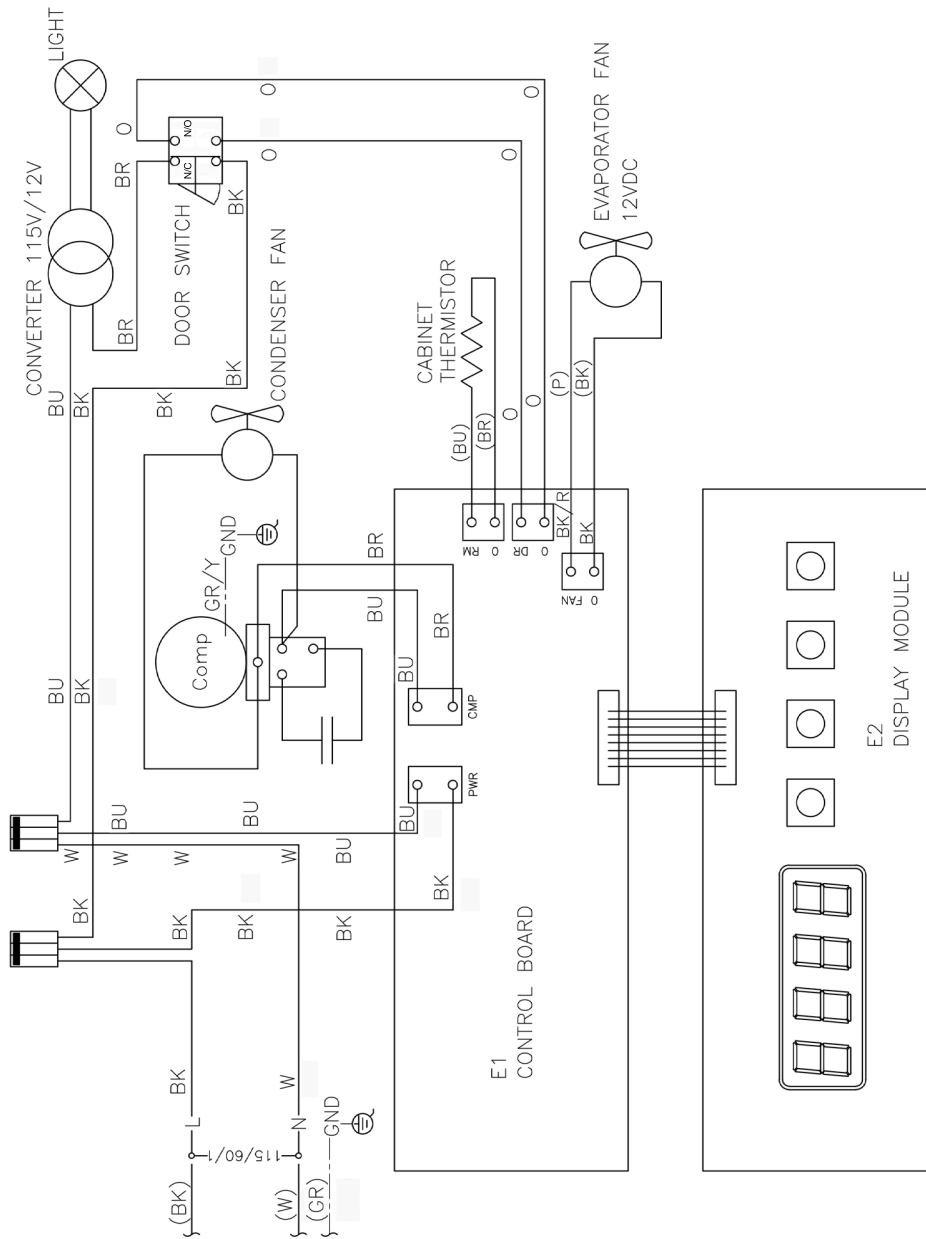

WIRE COLOR CODE

- BK BLACK
- BR BROWN
- BU BLUE
- GR GREEN
- O ORANGE
- P PINK
- R RED
- W WHITE
- BK/R BLACK/RED
- GR/Y GREEN/YELLOW

