

# Hoshizaki America, Inc.

## Commercial Kitchen Equipment

Model

Refrigerated Prep Table with Raised Rail



“A Superior Degree  
of Reliability”

[www.hoshizaki.com](http://www.hoshizaki.com)

## SERVICE MANUAL



Number: 73168  
Issued: 8-12-2009  
Revised: 5-11-2011

## **IMPORTANT**

Only qualified service technicians should install, service, and maintain the unit. No service or maintenance should be undertaken until the technician has thoroughly read this Service Manual. Failure to service and maintain the equipment in accordance with this manual may adversely affect safety, performance, component life, and warranty coverage.

Hoshizaki provides this manual primarily to assist qualified service technicians in the service and maintenance of the unit.

Should the reader have any questions or concerns which have not been satisfactorily addressed, please call, write or send an e-mail message to the Hoshizaki Technical Support Department for assistance.

HOSHIZAKI AMERICA, INC.  
618 Highway 74 South  
Peachtree City, GA 30269

Attn: Hoshizaki Technical Support Department

Phone: 1-800-233-1940 Technical Support  
(770) 487-2331

Fax: 1-800-843-1056  
(770) 487-3360

E-mail: techsupport@hoshizaki.com

Web Site: [www.hoshizaki.com](http://www.hoshizaki.com)

NOTE: To expedite assistance, all correspondence/communication MUST include the following information:

- Model Number \_\_\_\_\_
- Serial Number \_\_\_\_\_
- Complete and detailed explanation of the problem.

## IMPORTANT

This manual should be read carefully before the unit is serviced or maintenance operations are performed. Only qualified service technicians should install, service, and maintain the unit. Read the warnings contained in this booklet carefully as they give important information regarding safety. Please retain this booklet for any further reference that may be necessary.

## CONTENTS

Important Safety Information .....	6
I. Specifications.....	7
A. Nameplate Ratings.....	7
B. Dimensions .....	7
II. General Information .....	8
A. Construction.....	8
B. Sequence of Operation .....	9
1. Startup .....	9
2. Cool Down .....	9
3. Cool Down Achieved .....	9
4. Cool Down Restart .....	10
5. Cabinet Defrost.....	10
6. Rail Defrost.....	11
C. Sequence of Operation Charts .....	12
1. Cabinet Cooling.....	12
2. Cabinet and Rail Cooling.....	13
D. Control Board .....	15
1. Control Board Location.....	15
2. Control Board Layout .....	16
3. Features.....	17
4. Controls and Adjustments.....	18
a) Switch Settings .....	18
b) Temperature Display .....	18
c) Temperature Setpoint.....	19
d) Cabinet Defrost.....	19
e) Energy Saving Mode.....	19
f) Temperature Correction Factor.....	20
5. Service Menu .....	21
a) Service Menu Access .....	21
b) Service Menu Chart.....	22
6. Alarm Signals .....	23
7. Control Board Check Procedure.....	23
8. Control Board Replacement .....	23
E. Thermistor Check.....	24
F. Perimeter Heater.....	24
G. Compressor Protector .....	24

III. Service Diagnosis.....	25
A. Alarm Signals.....	25
1. High Temperature Alarm (E1).....	27
2. Low Temperature Alarm (E2).....	28
3. Cabinet Defrost Alarm (E3).....	29
4. High Condenser Temperature Alarm (clogged filter) (E7).....	30
5. Defrost Thermistor (cabinet) Malfunction Alarm (E8).....	31
6. Condenser Thermistor Malfunction Alarm (E9).....	32
7. Control Board Alarms (EA and ED).....	33
B. Service Chart.....	33
1. No Operation.....	33
2. Cabinet Cooling.....	34
3. Rail Cooling.....	36
4. Cabinet Defrost.....	37
5. Other.....	38
IV. Removal and Replacement of Components.....	39
A. Service for Refrigerant Lines.....	39
1. Refrigerant Recovery.....	39
2. Brazing.....	40
3. Evacuation and Recharge (R-404A).....	40
B. Removal and Replacement of Refrigeration System Cartridge.....	42
1. Refrigerant Recovery Procedure.....	42
2. Refrigeration System Pump-Down Procedure.....	44
C. Removal and Replacement of Compressor.....	47
D. Removal and Replacement of Cabinet Evaporator.....	48
E. Removal and Replacement of Expansion Valve.....	49
F. Removal and Replacement of Liquid Line Valve.....	50
G. Removal and Replacement of Condenser.....	51
H. Removal and Replacement of Thermistors and Thermostat.....	52
1. Cabinet Thermistor.....	52
2. Defrost Thermistor.....	52
3. Defrost Thermostat.....	53
4. Rail Thermistor.....	53
5. Condenser Thermistor (clogged filter).....	54
I. Removal and Replacement of Defrost Heater.....	54
J. Removal and Replacement of Fan Motors.....	55
1. Cabinet Fan Motor.....	55
2. Condenser Fan Motor.....	56
3. Rail Fan Motor.....	56
K. Removal and Replacement of Door Gasket.....	57
L. Door Re-Hinging and Drawer Conversion.....	57
V. Cleaning and Maintenance Instructions.....	58
A. Cleaning.....	58
1. Work Surface.....	58
2. Rail and Rail Cover.....	59
3. Exterior.....	59
4. Cabinet Interior.....	59

5. Door/Drawer Gaskets .....	59
6. Shelves (if applicable).....	59
7. Drawers (if applicable).....	59
B. Maintenance.....	60
1. Rail Condensate Pan .....	60
2. Air Filter.....	60
3. Condenser .....	60
4. Power Supply Connection.....	60
C. Shutdown and Long Storage.....	61
VI. Technical Information .....	62
A. Refrigeration Circuit .....	62
1. HPR46A(-D), HPR72A(-D), HPR100A(-D).....	62
B. Wiring Diagrams.....	63
1. HPR46A(-D).....	63
2a. HPR72A(-D) Auxiliary Code U-5 and Earlier .....	64
2b. HPR72A(-D) Auxiliary Code U-6 and Later .....	65
3. HPR100A(-D) .....	66

---

## Important Safety Information

Throughout this manual, notices appear to bring your attention to situations which could result in death, serious injury, or damage to the unit.

**⚠ WARNING** Indicates a hazardous situation which could result in death or serious injury.

**CAUTION** Indicates a situation which could result in damage to the unit.

**IMPORTANT** Indicates important information about the use and care of the unit.

### ⚠ WARNING

This unit should be destined only to the use for which it has been expressly conceived. Any other use should be considered improper and therefore dangerous. The manufacturer cannot be held responsible for eventual damage caused by improper, incorrect, and unreasonable use.

**To reduce the risk of death, electric shock, serious injury, or fire, follow basic precautions including the following:**

- This unit requires an independent power supply. See the nameplate for proper voltage and breaker/fuse size. Failure to use a proper breaker or fuse can result in a tripped breaker, blown fuse, or damage to existing wiring. This could lead to heat generation or fire.
- **THIS APPLIANCE MUST BE GROUNDED:** This unit is equipped with a 3-prong grounding plug to reduce the risk of potential shock hazards. It must be plugged into a properly grounded, independent 3-prong wall outlet. If the outlet is a 2-prong outlet, it is your personal responsibility to have a qualified electrician replace it with a properly grounded, independent 3-prong wall outlet. Do not remove the ground prong from the power cord and do not use an adapter plug.
- Do not use an extension cord.
- Make sure the power switch is in the "OFF" position before plugging in or unplugging the unit to reduce the risk of electric shock.
- Do not use a unit with a damaged power cord. The power cord should not be altered, jerked, bundled, weighed down, pinched, or tangled. Such actions could result in electric shock or fire. To unplug the unit, be sure to pull the plug, not the cord, and do not jerk the cord.
- To reduce the risk of electric shock, do not touch the plug or power switch with damp hands.
- This unit should be disassembled or repaired only by qualified service personnel to reduce the risk of electric shock, injury, or fire.
- Do not make any alterations to the unit. Alterations could result in electric shock, injury, fire, or damage to the unit.

# I. Specifications

## A. Nameplate Ratings

Model	AC Supply Voltage	Amperes	Design Pressure (PSIG)		Refrigerant
			HI	LO	404A
HPR46A(-D)	115/60/1	7.6	450	250	28.5 oz.
HPR72A		See Unit Nameplate			36.1 oz.
HPR72A-D		13.6			
HPR100A(-D)		TBD			TBD

## B. Dimensions

Model	Interior Volume Cu. Ft.	Rail Capacity QTY of 1/6 Sized Pans	Exterior Height (HE) mm (in.)	Worktop Height (HW) mm (in.)	Exterior Width (W) mm (in.)	Exterior Depth (D) mm (in.)	Interior Height mm (in.)	Interior Width mm (in.)	Interior Depth mm (in.)
HPR46A(-D) (1 Section)	8.5	12	1040 (40.95)	816 (32.13)	1168.4 (46)	858.5 (33.79)	640.5 (25.22)	604.1 (23.78)	641.8 (25.27)
HPR72A(-D) (2 Section)	18.8	18			1828.8 (72)			1309.1 (51.54)	
HPR100A(-D) (3 Section)	29.1	26			2533.8 (99.76)			2014.1 (79.30)	

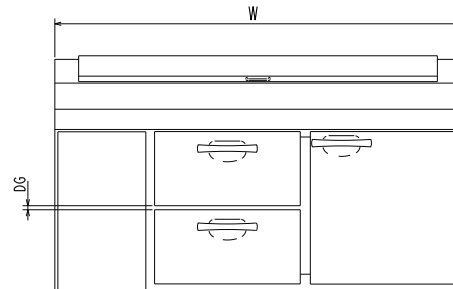
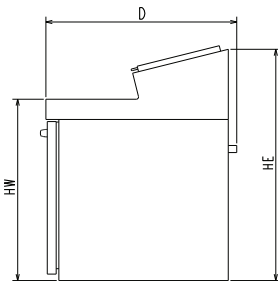

Model	Door Opening Height (DH) mm (in.)	Door Opening Width (DW) mm (in.)	Door Swing (DS) mm (in.)	Drawer Extension (DE) mm (in.)	Drawer Gap (DG) mm (in.)	Door Open Position	Rail Cover Open Positions	Caster Height mm (in.)
HPR46A(-D) (1 Section)	616.2 (24.26)	570.3 (22.45)	608.3 (23.95)	649.1 (25.56)	19 (0.75)	105°	45° and 65°	101.6 (4)
HPR72A(-D) (2 Section)								
HPR100A(-D) (3 Section)								

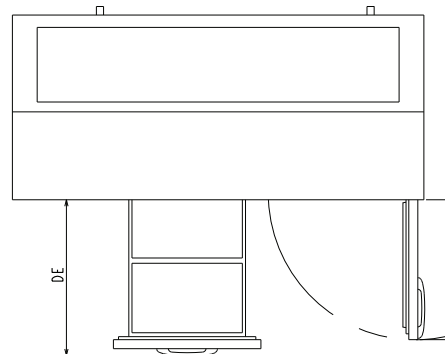
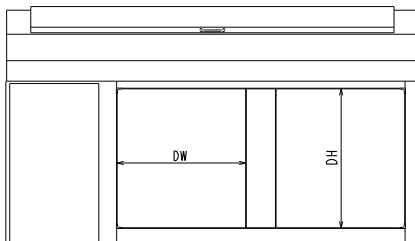

## II. General Information

### A. Construction

This Hoshizaki unit features a cartridge-type refrigeration system that can be removed (excluding the rail evaporator).

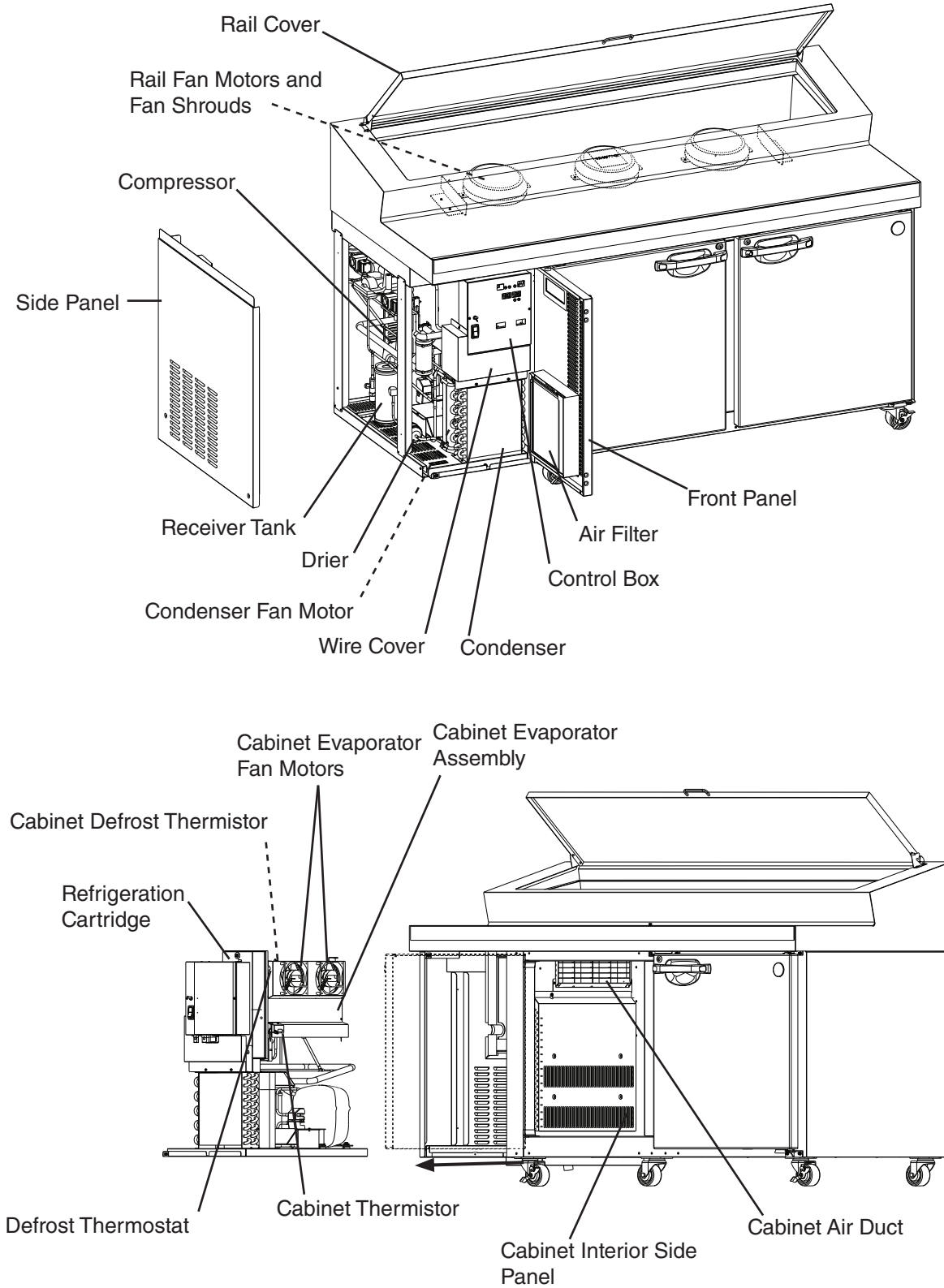

## B. Sequence of Operation

The steps in the sequence are as outlined below.

### 1. Startup

When the power switch is in the "ON" position, the cabinet temperature is displayed and cabinet cooling begins. When the power switch is in the "ON" position and the rail cooling switch is moved to the "NORMAL" or "LOW" position, the rail temperature is displayed and rail cooling begins. The "NORMAL" rail switch position is designed for use when the rail cover is open. The "LOW" rail switch position is designed for use when the rail cover is closed. For further details, see "II.D.4.a) Switch Settings."

#### **a) Power Switch "ON," Rail Cooling Switch "OFF"**

Cabinet temperature at or above setpoint: CabFM, CLLV, and PH energize. The 2 minute Comp delay timer and 6 hour DT start.

#### **b) Power Switch "ON," Rail Cooling Switch "NORMAL" or "LOW"**

Cabinet temperature and rail temperature at or above setpoint: CabFM, CLLV, PH, RailFM, and RLLV energize. The 2 minute Comp delay timer and 6 hour DT start.

### 2. Cool Down

#### **a) Power Switch "ON," Rail Cooling Switch "OFF"**

CabFM, CLLV, and PH continue. The 2 minute Comp delay timer expires and Comp and ConFM energize.

#### **b) Power Switch "ON," Rail Cooling Switch "NORMAL" or "LOW"**

CabFM, CLLV, PH, RailFM, and RLLV continue. The 2 minute Comp delay timer expires and Comp and ConFM energize.

### 3. Cool Down Achieved

To prevent Comp hard starts, CLLV (rail cooling switch "OFF") or RLLV (rail cooling switch "NORMAL" or "LOW") remains energized when Comp is off.

#### **a) Power Switch "ON," Rail Cooling Switch "OFF"**

CTh reaches 3.6°F (2°C) below setpoint. CabFM and PH continue, Comp and ConFM de-energize. CLLV de-energizes for 2 seconds (CLLV then remains energized during Comp off time).

#### **b) Power Switch "ON," Rail Cooling Switch "NORMAL" or "LOW"**

CTh, RTh, or both have reached 3.6°F (2°C) below setpoint.

##### *(1) Cabinet still cooling, RTh reaches 3.6°F (2°C) below setpoint*

CabFM, Comp, CondFM, CLLV, and PH continue. RailFM continues when rail cooling switch is in the "NORMAL" position and per F9 setting when in the "LOW" position. For details, see "II.D.4.a) Switch Settings." RLLV de-energizes.

##### *(2) CTh reaches 3.6°F (2°C) below setpoint, rail still cooling*

CabFM, Comp, CondFM, PH, RailFM, and RLLV continue. CLLV de-energizes.

(3) *Both CTh and RTh reach 3.6°F (2°C) below setpoint*

CabFM and PH continue. RailFM continues when rail cooling switch is in the "NORMAL" position and per F9 setting when in the "LOW" position. For details, see "II.D.4.a) Switch Settings." Comp, ConFM, and CLLV de-energize. RLLV de-energizes for 2 seconds. RLLV energizes, then remains energized during Comp off time.

#### **4. Cool Down Restart**

##### **a) Power Switch "ON," Rail Cooling Switch "OFF"**

CTh warms to setpoint, the CabFM, CLLV, and PH continue. 2 minute Comp delay timer starts. After the 2 minute delay timer expires, Comp and ConFM energize.

Cycle continues until power is turned off, the 6 hour DT expires and CB initiates a cabinet defrost, or the "MANUAL DEFROST" button is pressed for 5 seconds (evaporator temperature must be below 49°F (9.4°C)).

##### **b) Power Switch "ON," Rail Cooling Switch "NORMAL" or "LOW"**

CTh, RTh, or both have warmed to setpoint.

(1) *CTh at or above setpoint, RTh warms to setpoint*

CabFM, Comp, ConFM, CLLV, PH, continue. RailFM continues when rail switch is in the "NORMAL" position and resumes continuous operation when in the "LOW" position. RLLV energizes.

(2) *CTh warms to setpoint, RTh at or above setpoint*

CabFM, Comp, ConFM, PH, RailFM, and RLLV continue. CLLV energizes.

(3) *CTh or RTh warms to setpoint*

CabFM, PH, RailFM (RailFM continues when rail switch is in the "NORMAL" position and resumes continuous operation when in the "LOW" position), and RLLV continue. The 2 minute Comp delay timer starts. If CTh has warmed to setpoint and RTh has not, CLLV energizes and RLLV de-energizes. If RTh has warmed to setpoint and CTh has not, RLLV continues and CLLV remains de-energized. After the 2 minute Comp delay timer expires, Comp and ConFM energize.

#### **5. Cabinet Defrost**

The first cabinet defrost occurs 6 hours after the unit is turned on. Cabinet defrost is initiated when the 6 hour DT expires or the "MANUAL DEFROST" button is pressed for 5 seconds. Cabinet defrost termination occurs when the evaporator temperature reaches 49°F (9.4°C). Note that the defrost is a heated defrost, and therefore will have a tendency to raise the cabinet temperature. Cabinet temperature is not displayed during defrost; "dF" is displayed in its place. After defrost, there is a 5 minute delay before the compressor will start.

Note: To prevent Comp hard starts, CLLV (rail cooling switch "OFF") or RLLV (rail cooling switch "NORMAL" or "LOW") remains energized when Comp is off.

**a) Cabinet Defrost: Power Switch "ON," Rail Cooling Switch "OFF"**

CLLV continues, CabFM, Comp, ConFM, and PH de-energize. DH energizes and warms DTh to 49°F (9.4°C) (or the 100-minute defrost termination timer expires or DTst warms to 120°F±5°F (49°C±3°C)). When DTh reaches 49°F (9.4°C), DH de-energizes, CLLV continues and a 5 minute Comp delay timer starts. When the 5-minute Comp delay timer expires, CabFM and PH energize for 10 seconds. Comp and ConFM then energize and a 5-minute CabFM and PH delay timer starts. After the 5-minute CabFM and PH delay timer expires, CabFM and PH energize.

**b) Cabinet Defrost: Power Switch "ON," Rail Cooling Switch "NORMAL" or "LOW"**

*(1) Cabinet cool down achieved, rail still cooling*

Comp, CondFM, RailFM, and RLLV continue. CabFM and PH de-energize, and CLLV remains de-energized. DH energizes and warms DTh to 49°F (9.4°C) (or the 100-minute defrost termination timer expires or the DTst warms to 120°F±5°F (49°C±3°C)). When DTh reaches 49°F (9.4°C), DH de-energizes, Comp, ConFM, RailFM, and RLLV continue. CabFM and PH energize for 10 seconds. CLLV then energizes and a 5-minute CabFM and PH delay timer starts. After the 5-minute CabFM and PH delay timer expires, CabFM and PH energize.

*(2) Cabinet still cooling, rail cool down achieved*

RailFM continues (RailFM continues when rail switch is in the "NORMAL" position and per F9 setting when in the "LOW" position), RLLV and DH energize, CabFM, Comp, ConFM, and PH de-energize. CLLV de-energizes for 2 seconds, then energizes again. DH warms DTh to 49°F (9.4°C) (or the 100-minute defrost termination timer expires or the DTst warms to 120°F±5°F (49°C±3°C)). When DTh reaches 49°F (9.4°C), DH de-energizes, RailFM continues, RLLV de-energizes, CLLV energizes, and a 5-minute Comp delay timer starts. When the 5-minute Comp delay timer expires, CLLV and RailFM continue. CabFM and PH energize for 10 seconds. Comp and ConFM then energize and a 5-minute CabFM and PH delay timer starts. After the 5-minute CabFM and PH delay timer expires, CabFM and PH energize.

## **6. Rail Defrost**

For rail defrost (manual defrost), remove product from the rail area and store in a properly refrigerated area, then move the rail cooling switch to the "OFF" position.

Legend: **CabFM**—cabinet fan motor; **CB**—control board; **Comp**—compressor; **ConFM**—condenser fan motor; **CLLV**—cabinet liquid line valve; **CTh**—cabinet thermistor; **DH**—defrost heater; **DT**—defrost timer; **DTh**—defrost thermistor; **DTst**—defrost thermostat; **PH**—perimeter heater; **RailFM**—rail fan motor; **RLLV**—rail liquid line valve; **RTh**—rail thermistor

# C. Sequence of Operation Charts

## 1. Cabinet Cooling

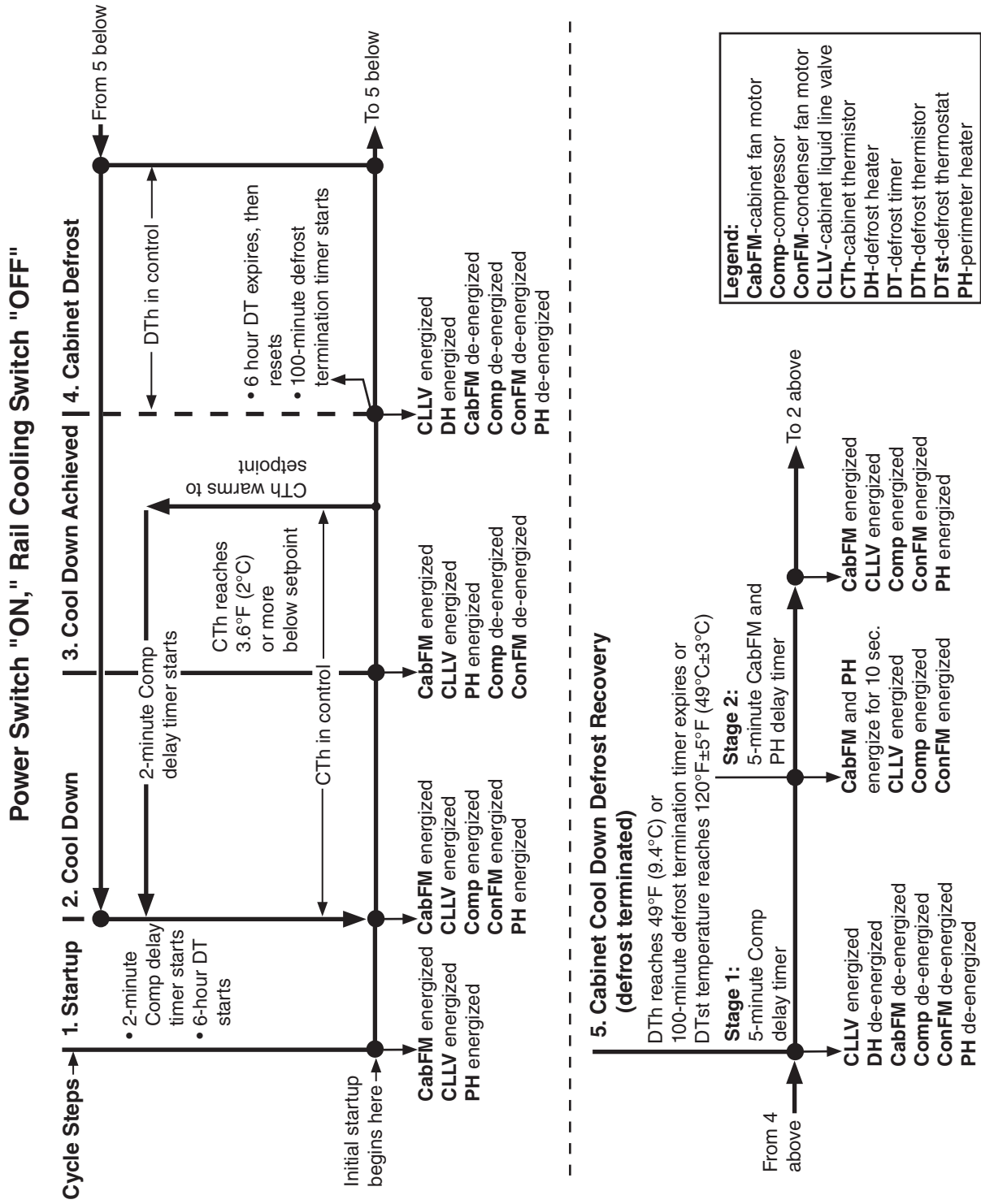

## 2. Cabinet and Rail Cooling

### Power Switch "ON," Rail Cooling Switch "NORMAL" or "LOW" Position

When in the "NORMAL" position, RailFM operates continuously.  
 When in the "LOW" position, RailFM operates continuously when rail is cooling down and intermittently (per F9 setting) when rail cool down is achieved. See "I.D.4.a) Switch Settings" and "I.D.5. Service Menu."

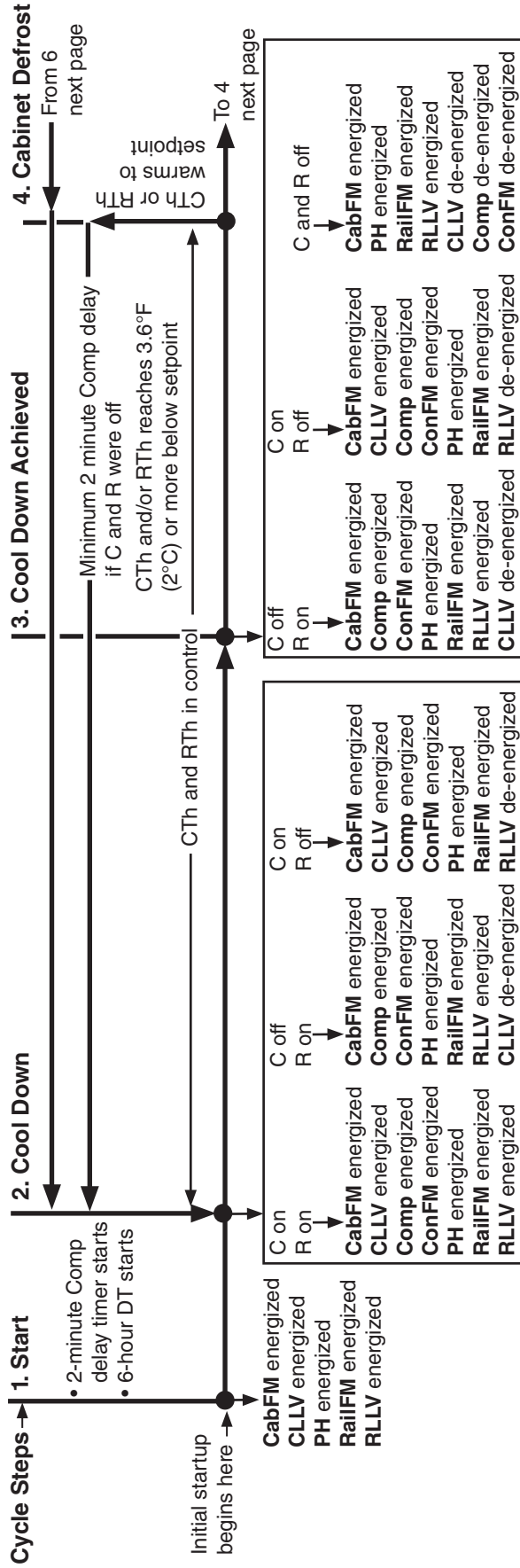

**Legend:**

C	cabinet cooling
CabFM	cabinet fan motor
Comp	compressor
ConFM	condenser fan motor
CLLV	cabinet liquid line valve
CTh	cabinet thermistor
DT	defrost timer
DH	defrost heater
DTh	defrost thermistor
DTst	defrost thermostat
PH	perimeter heater
R	rail cooling
RailFM	rail fan motor
RLLV	rail liquid line valve
RTh	rail thermistor

- C on-CTh at or above setpoint
- C off-CTh has reached 3.6°F (2°C) or more below setpoint
- R on-RTh at or above setpoint
- R off-RTh has reached 3.6°F (2°C) or more below setpoint

## 2. Cabinet and Rail Cooling (continued)

### Power Switch "ON," Rail Cooling Switch "NORMAL" or "LOW" Position (continued)

When in the "NORMAL" position, RailFM operates continuously.  
 When in the "LOW" position, RailFM operates continuously when rail is cooling down and intermittently (per F9 setting) when rail cool down is achieved. See "I.I.D.4.a) Switch Settings" and "I.I.D.5. Service Menu."

#### 4. Cabinet Defrost

- 6-hour DT expires, then resets
- 100-minute defrost termination timer starts

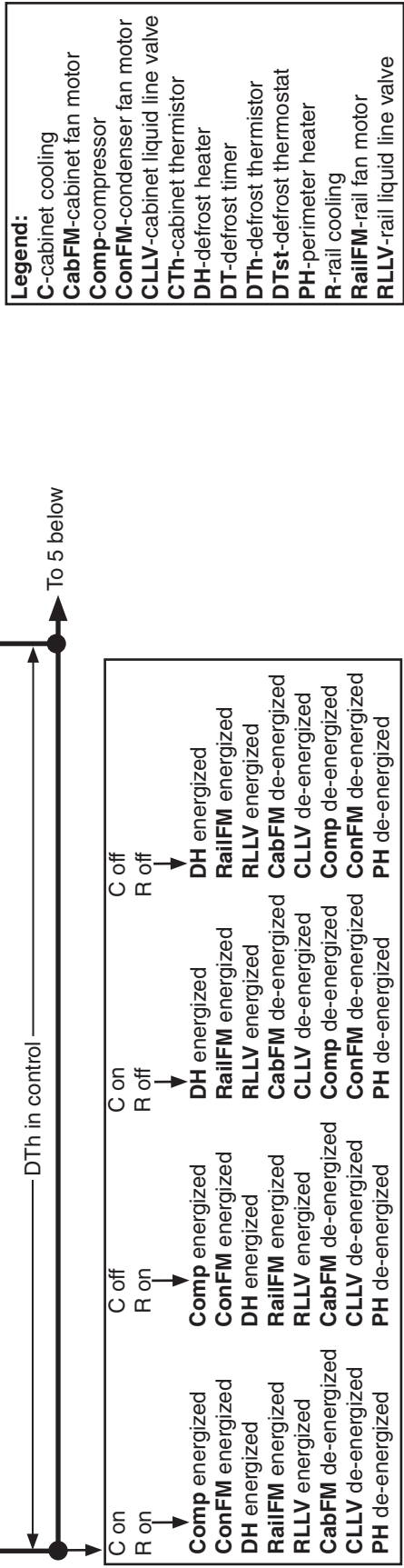

**Legend:**

- C-cabinet cooling
- CabFM-cabinet fan motor
- Comp-compressor
- ConFM-condenser fan motor
- CLLV-cabinet liquid line valve
- CTh-cabinet thermistor
- DH-defrost heater
- DT-defrost timer
- DTh-defrost thermistor
- DTst-defrost thermostat
- PH-perimeter heater
- R-rail cooling
- RailFM-rail fan motor
- RLLV-rail liquid line valve

#### 5. Cabinet Cool Down Defrost Recovery (defrost terminated)

DTh reaches 49°F (9.4°C) or 100-minute defrost termination timer expires or DTst temperature reaches 120°F± 5°F (49°C±3°C)

##### Stage 1:

When Comp is off: 5-minute Comp delay timer starts

When Comp is on: 5-minute recovery delay timer starts, Comp continues (rail on)

Stage 2: 5-minute CabFM and PH delay timer starts

To 2 previous page

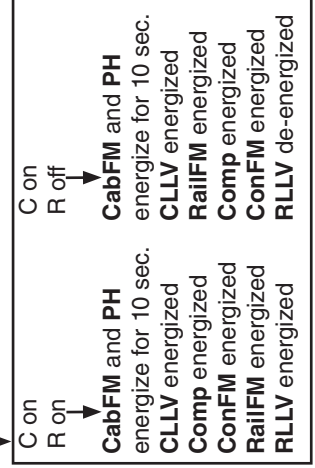
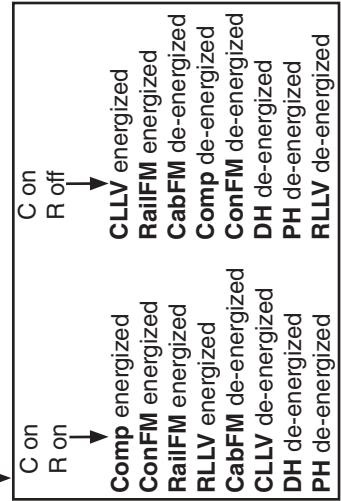

- C on-CTh at or above setpoint
- C off-CTh has reached 3.6°F (2°C) or more below setpoint
- R on-RTh at or above setpoint
- R off-RTh has reached 3.6°F (2°C) or more below setpoint

## D. Control Board

- A Hoshizaki exclusive solid-state control board is employed in all Hoshizaki HPR46A(-D), HPR72A(-D), and HPR100A(-D) units.
- All models are pretested and factory set.

### CAUTION

1. The control board is fragile; handle very carefully.
2. The control board contains integrated circuits, which are susceptible to failure due to static discharge. It is especially important to touch the metal part of the unit when handling or replacing the control board.
3. Do not touch the electronic devices on the control board or the back of the control board.
4. Do not attempt to repair the control board.
5. Do not short out power supply to test for voltage.
6. Keep the thermistor leads and pressure switch leads at least 1.5" (38 mm) away from high voltage leads (100Vac or more) to protect against electrical noise.

## 1. Control Board Location

The control panel is located behind the front panel. Follow the instructions and warnings for safe and efficient operation of the unit.

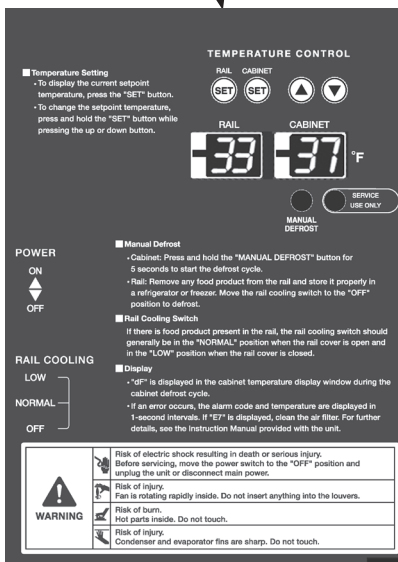
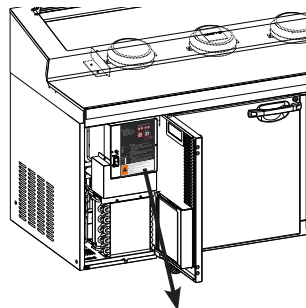

## 2. Control Board Layout

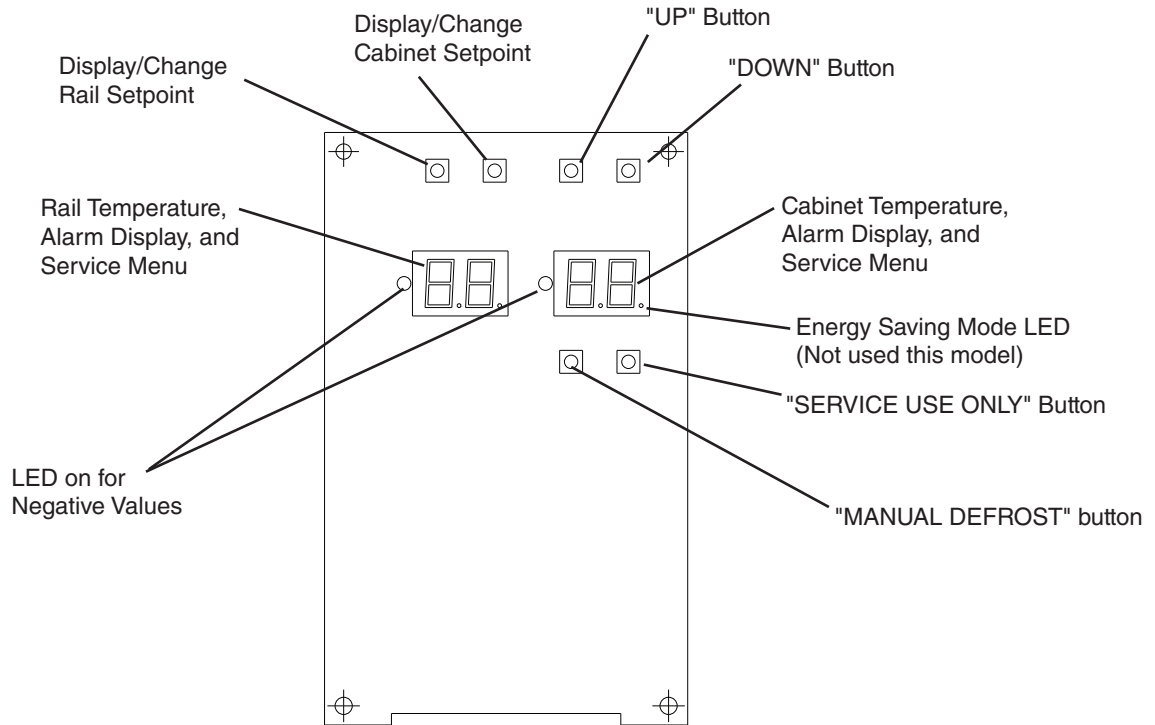

**Front**

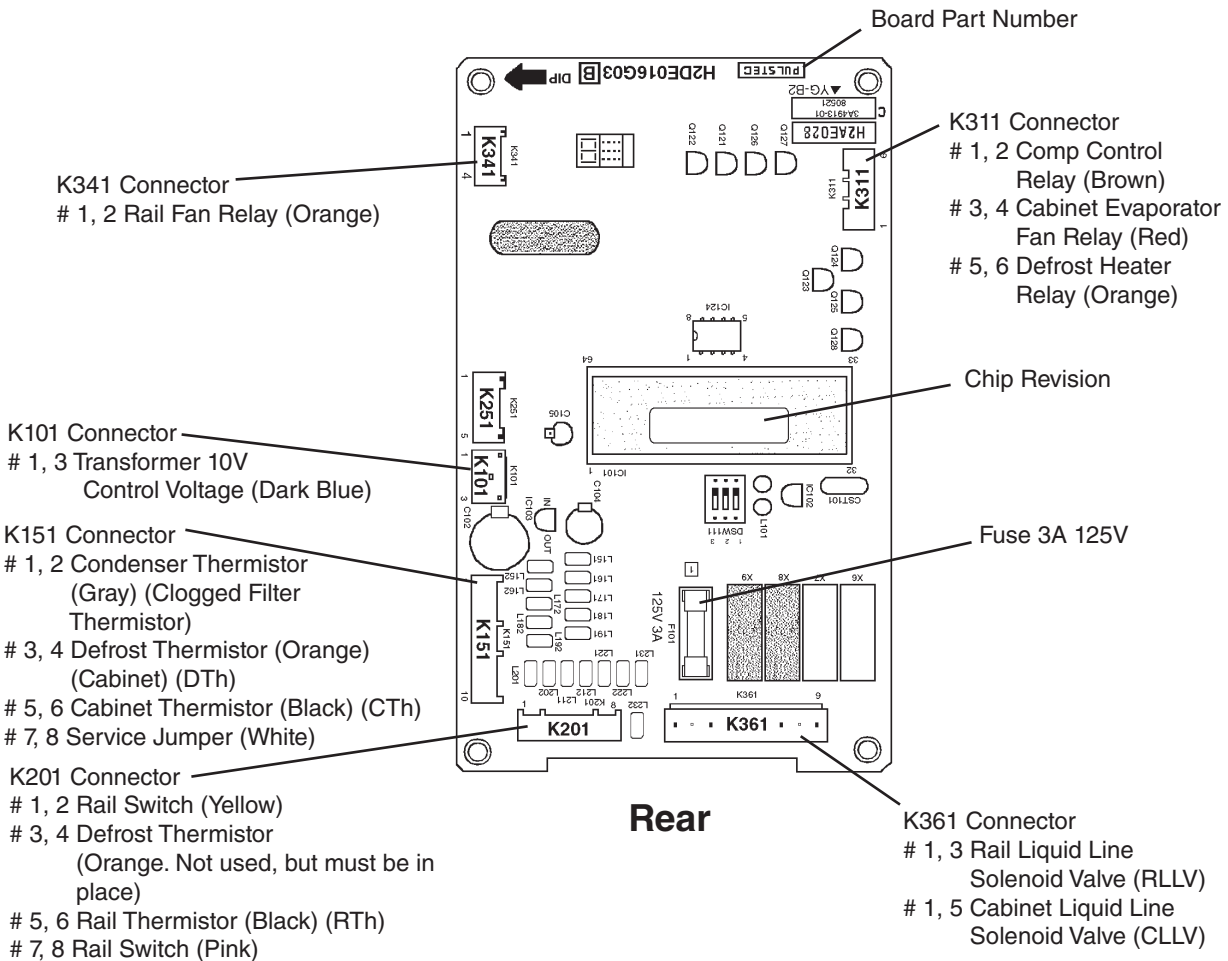

**Rear**

### 3. Features

#### **a) LED Display and Service Lock-Out**

This control board uses twin LED displays to show system details and diagnostic information. For control board voltage protection, a 3A 125V fuse is incorporated into the control board circuitry. A service jumper is also provided to protect against unwanted changes to the unit's settings. This service lock-out jumper is located on the K151 connector terminals 7 and 8. See "II.D.4. Controls and Adjustments."

#### **b) Compressor Short Cycle Protection**

The start circuit of the compressor is timed such that at power-up and during any compressor off time, there will be at least a 2 minute delay before the compressor will start. This protects the compressor against short cycling and potential compressor damage or failure. To bypass the 2 minute compressor delay timer (for unit diagnostics), press and hold the rail "SET" button and move the power switch to the "ON" position.

#### **c) Alarm Signal**

Alarm signals (E1 to E9, EA and ED) are designed to protect the unit and food product. These alarms give information or warnings in the event the unit is operating out of acceptable parameters. See "III.A. Alarm Signals."

#### **d) Service Menu**

A service menu (F0 to F9) allows for viewing and setting of system operating details and parameters. See "II.D.5. Service Menu."

#### **e) Automatic and Manual Defrost Capabilities**

This unit features automatic and manual cabinet defrost capabilities. See "II.D.4.d) Cabinet Defrost."

#### 4. Controls and Adjustments

The cabinet and rail temperatures are updated every 30 seconds. The control board is supplied with a service jumper on the K151 connector. Only the temperature setpoint and the temperature scale ("F5") may be adjusted with this connector in place. To view or adjust other selections, see "II.D.5. Service Menu."

##### a) Switch Settings

**Power Switch "OFF":** Unit off (both cabinet and rail).

**Power Switch "ON":** Cabinet temperature is displayed and cabinet cooling begins. Cabinet fans and perimeter heaters are on and run continuously (except during defrost).

**Rail Cooling Switch "OFF":** Rail cooling off, cabinet cooling continues.

**Rail Cooling Switch "NORMAL:** Designed for use when the rail cover is open. Rail temperature display on and rail cooling begins. The rail fans operate continuously.

**Rail Cooling Switch "LOW":** Designed for use when the rail cover is closed. Rail temperature display is on and rail cooling begins. The rail fans operate intermittently when "F9" is at the factory default setting. For access and adjustments to the "F9" setting, see "II.D.5. Service Menu."

Note: A Hoshizaki OEM rail cooling switch must be used if replacing the rail cooling switch. For details see "IV.M. Rail Cooling Switch."

##### b) Temperature Display

The temperature display can be changed between Fahrenheit and Celsius. To change the temperature display, press and hold the cabinet "SET" button and the "SERVICE USE ONLY" button for 5 seconds. "F0" appears in the display screen. Press the up arrow button until "F5" appears in the display screen. "F5" is the only service menu selection accessible with the service jumper in place.

Press the cabinet "SET" button to view the temperature display setting. Press the up or down arrow button to switch between F° and C°. Press the cabinet "SET" button to save the new setting. Press the cabinet "SET" button and the "SERVICE USE ONLY" button for 5 seconds to return to normal temperature display.

"SET" buttons used to view current temperature settings.  
Cabinet "SET" button used with "SERVICE USE ONLY" button to enter and exit the service menu.

"UP" and "DOWN" arrow buttons used to change temperature settings, scroll through the service menu, and to change menu settings.

"SERVICE USE ONLY" button used with cabinet "SET" button to enter and exit the service menu.

"MANUAL DEFROST" button used to initiate a manual defrost.

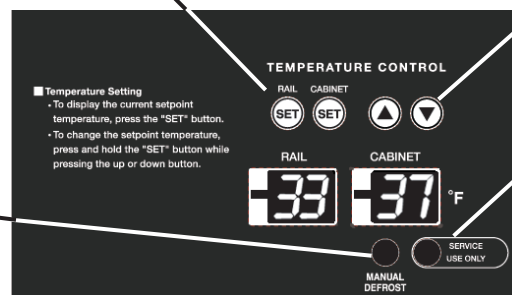

### c) **Temperature Setpoint**

The temperature setpoint is the temperature setting at which the compressor turns on. The factory default temperature setpoints are 37° (3°C) for the cabinet and 33°F (1°C) for the rail (see the chart below).

The temperature differential for the compressor to turn off is 3.6°F (2°C) below the temperature setpoint. The temperatures are updated every 30 seconds. If necessary, adjust the temperature setpoint as outlined below.

Note: The cabinet and rail temperature setpoints must be changed individually.

- 1) Press the appropriate "SET" button to display the current temperature setpoint.
- 2) Press and hold the appropriate "SET" button while pressing the up or down arrow button. See the chart below for temperature setpoint ranges.
- 3) Release the "SET" button. As long as the unit is not turned off, the new setpoint will be saved automatically after 10 seconds.

Section	Temperature Setpoint Range	Default
Cabinet	21 to 53°F (-6 to +12°C)	37°F (3°C)
Rail	-13 to +53°F (-25 to +12°C)	33°F (1°C)

### d) **Cabinet Defrost**

The automatic cabinet defrost is factory set for once every 6 hours. See "II.D.5. Service Menu." The cabinet defrost thermistor will signal the control board to start a defrost once the 6 hour defrost timer has expired and the cabinet evaporator temperature is below 49°F (9.4°C). Defrost is heated, and therefore will have a tendency to raise the cabinet temperature.

For a manual cabinet defrost press the "MANUAL DEFROST" button on the control board for 5 seconds to initiate a defrost. This will restart the 6-hour defrost timer.

Cabinet temperature is not displayed during defrost; "dF" is displayed in its place. The control board will terminate the cabinet defrost and begin defrost recovery when a signal from the cabinet defrost thermistor is greater than 49°F (9.4°C). After defrost, there is a 5-minute delay before the compressor will start.

This unit has an additional defrost thermistor located behind the wire cover that connects to the K201 connector, terminals 3 and 4. This thermistor is not used for defrost purposes on this model, but must be in place for proper operation of the control board.

### e) **Energy Saving Mode**

"Energy Saving Mode" is not used on this unit. The "Energy Saving Mode" LED is located to the bottom right of the cabinet display and should be off. See "II.D.2. Control Board Layout." If the "Energy Saving Mode" LED is on, press the "SERVICE USE ONLY" button for 5 seconds to exit and disable the "Energy Saving Mode."

**f) Temperature Correction Factor**

In cases where there is a discrepancy between the actual cabinet or rail temperature and the displayed temperature, a temperature correction factor is used to correct the displayed temperature.

**⚠ WARNING**

This unit has been factory tested with the default settings listed. Avoid using this function except to confirm that the setting is correct. If set incorrectly, the display could show an acceptable temperature even though the temperature is out of the proper range. This value should only be changed after consulting with the Hoshizaki Technical Support Department at 1-800-233-1940.

To view the current values, move the power switch to the "ON" position while pressing the up arrow button. The current cabinet temperature correction factor will be shown. If "18" is displayed, the value is 1.8°F (1°C). Press the cabinet "SET" button to display the rail temperature correction factor.

Temperature Correction Factor		Default		
Area	Setting Range	1-Section	2-Section	3-Section
Cabinet	-9 to 9°F in 0.9°F increments	0°F (0°C)		TBD
Rail	(-5 to 5°C in 0.5°C increments)	1.8°F (1°C)	(0.9°F (0.5°C))	TBD
Negative values are indicated by an LED to the left of the value (Decimals are not shown on display)				

If it is determined through discussion with Hoshizaki Technical Support that the setting needs to be changed, follow the steps below.

- 1) Display the cabinet or rail temperature correction factor as outlined above.
- 2) Press the up or down button to increase or decrease the cabinet value.
- 3) Press the cabinet "SET" button to save the new cabinet value.
- 4) Press the cabinet "SET" button again to view the rail value.
- 5) Press the up or down button to increase or decrease the rail value.
- 6) Press the cabinet "SET" button to save the new rail value.
- 7) Turn the power off and then back on. The unit will start running with the new value(s).

**[Example]**

When the actual cabinet temperature is 5.4°F (3°C) higher than the displayed temperature, change the temperature correction factor to 5.4°F (3°C), so that the displayed temperature matches the cabinet temperature.

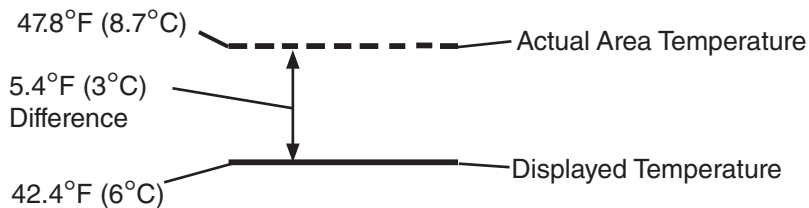

## 5. Service Menu

The service menu ("F0" to "F9") may be used to change settings, acquire diagnostic information, and to view alarm history.

To access the "F0" through "F9" service menu selections, you must first disconnect the service jumper (excluding "F5" which is accessible with or without the service jumper in place). The service jumper is located behind the wire cover below the control box and connects the control board K151 connector terminals 7 and 8 (white) together. When the service jumper is in place, only the "F5" selection is accessible. Be sure to reconnect the service jumper when finished.

### a) Service Menu Access

- Enter Service Menu: Press and hold the cabinet "SET" button and the "SERVICE USE ONLY" button for 5 seconds. "F0" should appear in the display screen.
- Scroll: Use the up and down arrow buttons to scroll through the service menu list, settings, and data.
- View Service Menu Setting: Press the cabinet "SET" button to view the selected menu setting.
- Save Setting: Press the cabinet "SET" button to save the new setting.
- Return to Service Menu List: Press the cabinet "SET" button once again to return to the main service menu list.
- Exit Service Menu: Press and hold the cabinet "SET" button and the "SERVICE USE ONLY" button for 5 seconds to exit the service menu at any time. If no button is pressed, the control board will return to the normal temperature display after 1 minute.

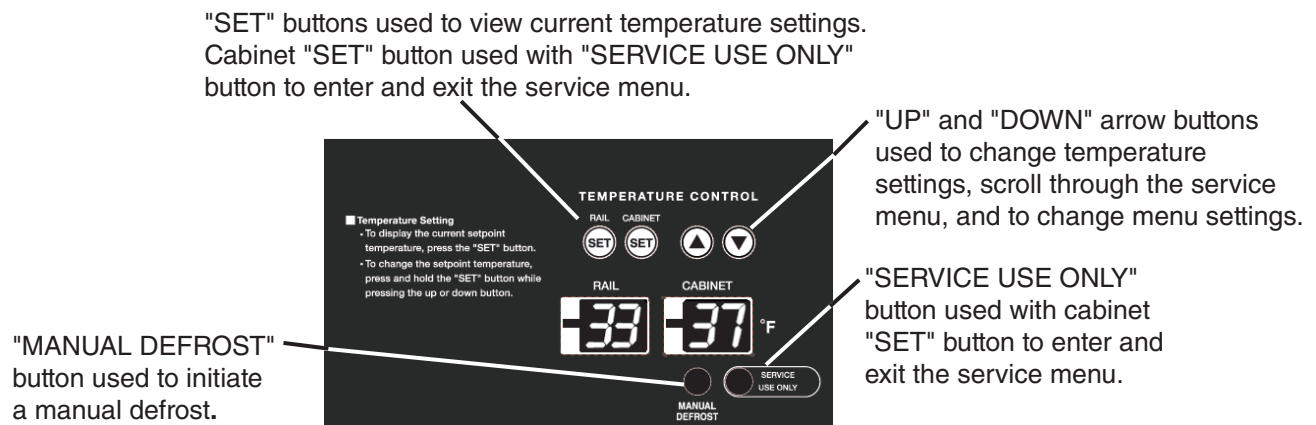

**b) Service Menu Chart**

Service Menu	Item and Details	Setting Range		Factory Default	
		Cabinet	Rail	Cabinet	Rail
F0	Defrost Interval <ul style="list-style-type: none"> <li>The cabinet uses a time initiated heated defrost.</li> <li>The change in the defrost interval setting will take effect immediately. The next defrost will take place after the newly set time interval has elapsed.</li> <li>Initiating a manual defrost on the cabinet will restart the defrost timer.</li> </ul>	1 to 12 hours in 1 hour increments.	N/A	6	N/A
F1	Defrost Termination Temperature Do not adjust. For recommendations, contact Hoshizaki Technical Support.	41 to 68°F (5 to 20°C) in 1 degree increments	N/A	49°F (9.4°C)	N/A
F2	Setpoint Temperature Differential Use "SET" button to scroll through all 4 settings. <ul style="list-style-type: none"> <li>You cannot set both + and - to 0.0.</li> <li>Negative value indicated by LED to left of number.</li> </ul>	Both the + and - values can be adjusted between 0 to 6.3°F in increments of .9°F (0 to 3.5°C in increments of .5°C) (decimal not displayed)		Comp on 0°F (0°C) at setpoint  Comp off -3.6°F (-2°C) below setpoint	Comp on 0°F (0°C) at setpoint  Comp off -3.6°F (-2°C) below setpoint
F3	High Temperature Alarm Delay Time: See "III.A. Alarm Signals."	0 to 3 hours in 1 hour increments		2	
F4	Low Temperature Alarm Delay Time: See "III.A. Alarm Signals."	0 or 1 hour		1	
F5	Temperature Display	Fahrenheit or Celsius		°F	
F6	Alarm History: maximum 8 alarms.  No reset for alarm history available.	Alarms displayed newest to oldest. When "--" appears, you have reached the end of the alarm history.		N/A	
F7	Compressor Run Time (%): Displays compressor run time percentage between the 2 most recent defrosts.	N/A		N/A	
F8	Not Used	N/A		N/A	
F9	Rail Cooling Switch: "LOW" Rail Fan Adjustment (rail section only)	0=rail fans on continuously (same as "NORMAL" position) 1=rail fans on 15 sec. rail fans off 90 sec. 2=rail fans on 1 sec. rail fans off 90 sec.		N/A	2
FA Do not adjust	High Condenser Temperature Alarm Setting (clogged filter): For recommendations, contact Hoshizaki Technical Support.	Adjustable between 140 to 167°F (60 to 75°C).		140°F (60°C) (1 not displayed)	
Fb	Audible Control	N/A		N/A	

## 6. Alarm Signals

In the event of operation outside of normal parameters, the control board identifies the issue with an alarm signal. The alarm signal and temperature are displayed in 1-second intervals. For service corrections, see "III.A. Alarm Signals."

Alarm Signals	
E1	High Temperature Alarm
E2	Low Temperature Alarm
E3	Defrost Alarm (cabinet only)
E4	Not Used
E7	High Condenser Temperature Alarm (clogged filter)
E8	Defrost Thermistor Malfunction Alarm
E9	Condenser Thermistor Malfunction Alarm
EA	EEPROM Write Error Alarm
ED	EEPROM Verification or Read Error Alarm

## 7. Control Board Check Procedure

Before replacing a control board that does not show a visible defect and that you suspect is bad, always conduct the following check procedure. This procedure will help you verify your diagnosis. Before you begin the diagnostics, verify proper supply voltage and that the unit is correctly plugged in.

- 1) Move the power switch to the "ON" position and the rail switch to the "NORMAL" position. Both cabinet and rail temperatures should be displayed. The perimeter heater, cabinet fans, and rail fans should be on.
- 2) If the temperature display is not on, check the 3A 125V fuse on the control board and the control transformer secondary circuit. Secondary transformer output is 10V at 115V primary input. If the fuse and the secondary circuit voltage are good, but the temperature display is off, the control board is bad and should be replaced.
- 3) If the temperature display is on and the components are not energizing, verify 12VDC to the corresponding relay. If there is no voltage to the component relay, the control board is bad and should be replaced.

## 8. Control Board Replacement

- 1) Open the front panel. Move the power switch to the "OFF" position, then unplug the unit.
- 2) Remove the wire cover, then remove the control box cover.
- 3) Disconnect the control board wire connectors.
- 4) Remove the control board.
- 5) Install the new control board in the control box taking care not to damage it.
- 6) Connect the control board wire connectors to the new control board.
- 7) Replace the control box cover in its correct position.
- 8) Plug in the unit, then move the power switch to the "ON" position to start the unit's cooling process.
- 9) Check the setpoint and service menu settings and verify that they are set to the factory defaults. See "II.D.4. Controls and Adjustments" and "II.D.5. Service Menu."

## **E. Thermistor Check**

Thermistors (semiconductors) are used for temperature control in the cabinet and rail areas, defrost termination, and for monitoring condenser temperature (clogged filter). The resistance varies depending on temperature. No adjustment is required. If necessary, check for resistance between thermistor leads and visually check the thermistor mounting.

- 1) Disconnect the connector for the thermistor in question under the control box and behind the wire guard.
- 2) Remove the thermistor. See "IV.H. Removal and Replacement of Thermistors and Thermostat."
- 3) Immerse the thermistor portion in a glass or cup containing ice and water for 2 or 3 minutes.
- 4) Check for a resistance between thermistor leads. Normal reading is from 5 to 6.5 k $\Omega$  for the cabinet, rail, and defrost thermistors and 145 to 175 k $\Omega$  for the condenser thermistor. Replace the thermistor if it exceeds the normal reading.

## **F. Perimeter Heater**

This unit is equipped with a perimeter heater. This prevents the formation of condensate on the frame of the unit under high humidity conditions. The unit incorporates a redundant perimeter heater in the event the main perimeter heater should fail.

## **G. Compressor Protector**

When a combined temperature/ampere value is above the limit specified by the compressor manufacturer, a protector will operate independently, turning off the compressor. The compressor will restart when this protector has reset.

Note:

1. Compressor protector resets automatically.
2. If the condenser fan is operating and the compressor is off, it is most likely that the protector has operated.

### III. Service Diagnosis

#### ⚠ WARNING

1. This unit should be disassembled or repaired only by a qualified service technician to reduce the risk of injury, electric shock, or fire.
2. Do not make any alterations to the unit. This could cause water leak, electric shock, or fire.
3. To help reduce the risk of electric shock, do not touch the attachment plug or switches with damp hands.
4. In case of insufficient refrigeration performance, move the stored food product into another unit to prevent its deterioration.

#### A. Alarm Signals

In the event of operation outside of normal parameters, the control board identifies the issue with an alarm signal. The alarm signal and cabinet temperature are displayed in 1-second intervals. For further service information, see "III.B. Service Chart." If multiple alarms occur simultaneously, only the alarm with the higher priority is displayed.

Alarm Signal	Priority	Problem	Reset, Corrections, and Adjustments
E1	8	High Temperature Alarm (cabinet only)  Cabinet temperature has exceeded the setpoint temperature by 18°F (10°C) for more than x hours. The default value of x is "2".	When the temperature returns to the setpoint range, alarm resets.  Close doors/drawers and clean the condenser and air filter. Check for refrigerant leaks. Check cabinet thermistor.  The value of x can be changed under "F3" on the Service Menu. (0=No delay; 1=1 hour; 2=2 hours; 3=3 hours)
E2	9	Low Temperature Alarm (cabinet only)  Cabinet temperature has remained below the setpoint by 9°F (5°C) for more than y hours. The default value of y is "1".	When the temperature returns to the setpoint range, alarm resets.  Ambient temperature too low. Check thermistor, liquid line valve sticking, fans not operating.  The value of y can be changed under "F4" on the Service Menu. (0=No delay; 1=hour)
E3	7	Defrost Alarm (cabinet only)  Cabinet defrost has taken longer than 1 hour. The control board has terminated defrost.	Turn the power off, then back on.  Check defrost heater, defrost thermistor.  Note that "E3" may alternate with "dF" instead of the temperature.

<b>Alarm Signal</b>	<b>Priority</b>	<b>Problem</b>	<b>Reset, Corrections, and Adjustments</b>
<b>E7</b>	6	High Condenser Temperature Alarm (clogged filter)  Condenser temperature is outside of normal operating temperature. 140°F (60°C)	Turn the power off, then back on.  Condenser and/or air filter dirty. Fan motor not turning. Possible restriction in refrigeration system.  Failure to take action when this alarm activates could result in damage to the compressor.
<b>E8</b>	3	Defrost Thermistor Malfunction Alarm  Defrost thermistor shorted or open.	After replacing defrost thermistor, alarm resets.
<b>E9</b>	4	Condenser Thermistor Malfunction Alarm  Condenser thermistor shorted or open.	After replacing condenser thermistor, alarm resets.
<b>EA</b>	2	EEPROM Write Alarm  Control board has failed.	After replacing control board, alarm resets.
<b>ED</b>	1	EEPROM Verification or Read Alarm  Control board has failed.	After replacing control board, alarm resets.

## 1. High Temperature Alarm (E1)

If the cabinet or rail temperature exceeds the setpoint temperature by 18°F (10°C) or more for more than x hours, "E1" is displayed. The default value of x is "2" (2 hours). The value of x can be changed under "F3" on the service menu. (0=No delay; 1=1; 2=2; 3=3 hours)

Note:

- After the machine has been turned off and then turned back on, the high temperature alarm feature is not active until the area temperature reaches the lower setpoint temperature differential.
- The high temperature alarm feature operates even during defrost.

### Reset Options

The alarm will automatically reset once the area temperature reaches the lower setpoint temperature differential.

**Possible Causes** (for further details, see "III.B. Service Chart")

- Doors or drawers are opened frequently or are not completely closed.
- Trouble with the compressor or a refrigerant leak.
- Trouble with the cabinet or rail thermistor.
- Liquid line valve closed.

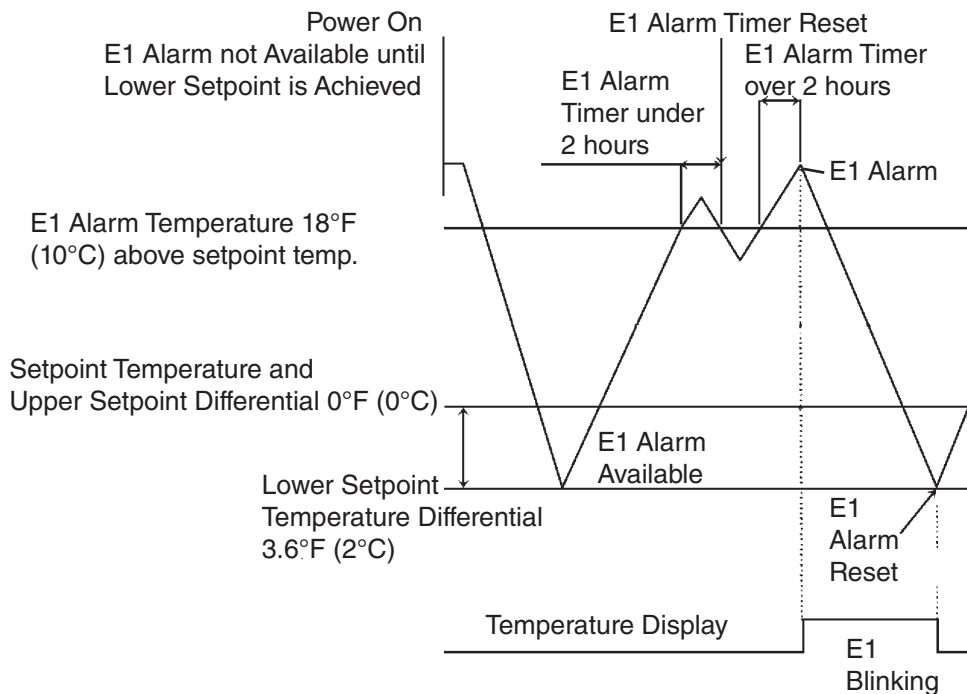

## 2. Low Temperature Alarm (E2)

If the cabinet or rail temperature drops below the setpoint temperature by 9°F (5°C) or more for more than y hours, "E2" is displayed. The default value of y is "1" (1 hour). The value of y can be changed under "F4" on the service menu. (0=No delay; 1=1 hour)

Note:

- The low temperature alarm timer starts once the cabinet temperature drops 9°F (5°C) below the setpoint temperature.
- The low temperature alarm feature operates even during defrost.

### Reset Options

The alarm will automatically reset once the area temperature reaches the upper setpoint temperature differential.

**Possible Causes** (for further details see "III.B. Service Chart")

- Ambient temperature is low.
- Trouble with the cabinet thermistor (black).
- Liquid line valve open.
- Evaporator fans not operating.

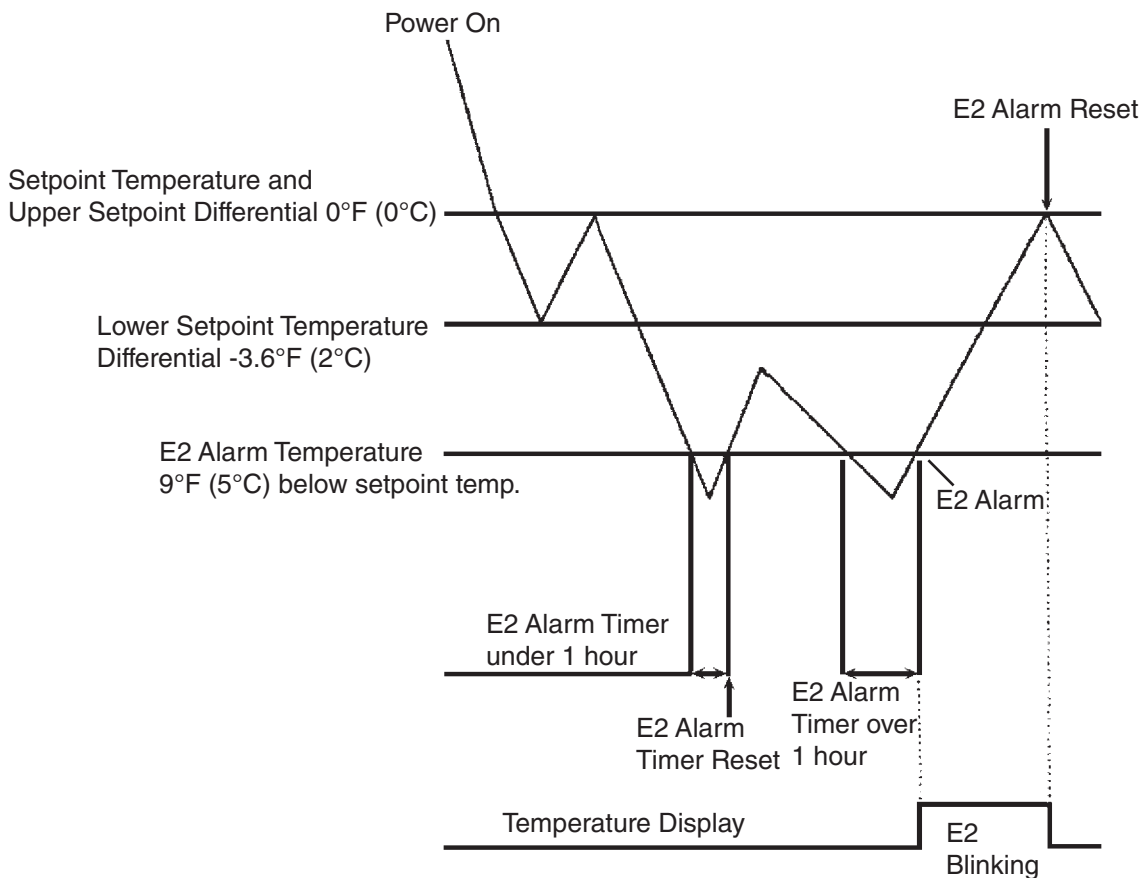

### **3. Cabinet Defrost Alarm (E3)**

Once the defrost termination temperature is reached, the signal from the defrost thermistor should terminate the defrost. If the defrost thermistor does not terminate the defrost within 100 minutes (1 hour and 40 minutes), "E3" is displayed. When "E3" is displayed, the next step in the defrost process begins.

#### **Reset Options**

To reset the alarm, turn the power off and then back on.

#### **Possible Causes** (for further details see "III.B. Service Chart")

- Trouble with the defrost heater.
- Trouble with the defrost thermistor.
- Trouble with the control board.

#### 4. High Condenser Temperature Alarm (clogged filter) (E7)

The unit is equipped with a condenser air filter to protect the condenser from dirt, grease, etc. The condenser air filter promotes clean condenser surfaces and efficient operation and should be checked twice monthly and cleaned when necessary. The unit is also equipped with a condenser thermistor to determine if the condenser or condenser air filter is excessively dirty. If the condenser thermistor detects a temperature that exceeds the preset temperature value (136.4°F (58°C)) for over 2 minutes, "E7" will be displayed.

### CAUTION

Failure to take action when this alarm activates could result in damage to the compressor.

#### Reset Options

After cleaning the filter, the alarm will automatically reset once the temperature at the condenser outlet drops below 136.4°F (58°C).

#### Possible Causes (for further details see "III.B. Service Chart")

- The condenser or condenser air filter is dirty.
- The condenser fan motor is not functioning.

Note: If the power is turned off and then back on while the alarm signal is displayed, the alarm may be reset even if the condenser or condenser air filter has not been cleaned. However, the alarm will repeat once the compressor discharge temperature reaches 136.4°F (58°C).

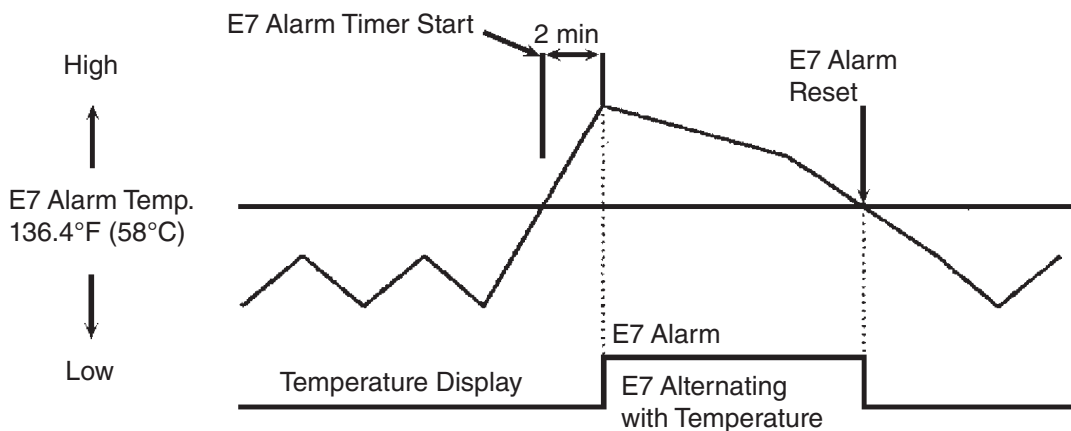

## 5. Defrost Thermistor (cabinet) Malfunction Alarm (E8)

If the control board detects an open defrost thermistor, "E8" is displayed. When the control board detects a shorted defrost thermistor, a 10-minute delay timer begins. After the 10-minute delay timer expires, "E8" is displayed. To bypass the 10-minute delay timer, move the power switch to the "OFF" position. Then, while pressing the rail "SET" button, move the power switch to the "ON" position.

- If this alarm appears, first make sure that the thermistor is properly connected to the control board.
- A shorted defrost thermistor is not detected by the control board during the 1st hour after power is turned on. To bypass the 1-hour delay timer, move the power switch to the "OFF" position. Then, while pressing the rail "SET" button, move the power switch to the "ON" position.

### Reset Options

The alarm automatically resets when one of the following conditions is met:

- The defrost thermistor is secured to the control board.
- The defrost thermistor is within normal operating range. For details, see "II.E. Thermistor Check."
- A functioning defrost thermistor is installed.

### Possible Causes

- Trouble with the defrost thermistor. For checkout procedure, see "II.E. Thermistor Check."
- Trouble with the control board reading the defrost thermistor.

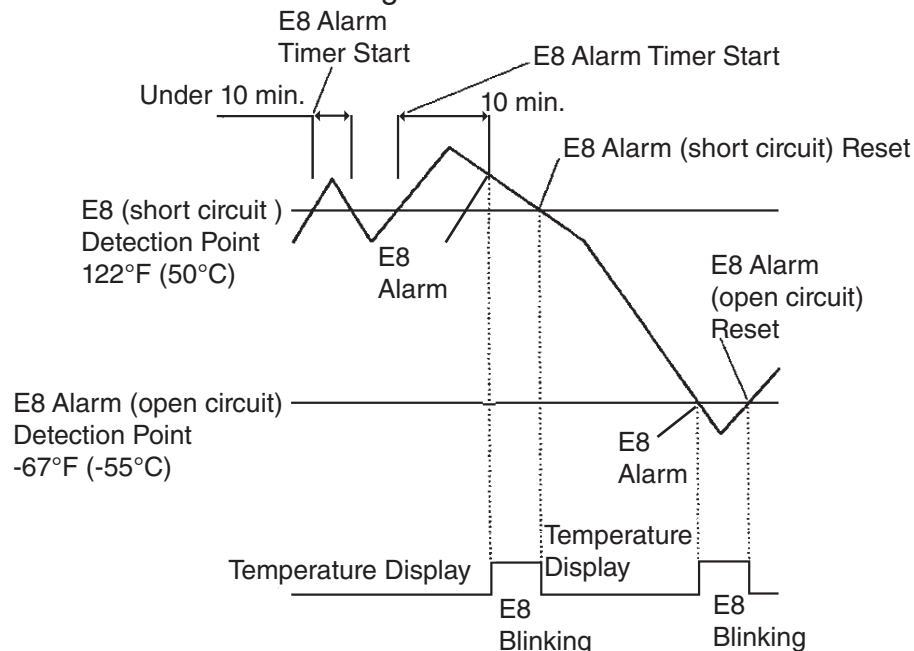

### 5a. Secondary Defrost Thermistor (Rail, not used)

The secondary defrost thermistor (located behind the wire cover) is not used for operation of the unit. It is used for control board programming and should not be removed. An "E8" alarm occurs when the secondary defrost thermistor is removed or fails. For details, see "III.A.6. Defrost Thermistor (cabinet) Malfunction Alarm (E8)."

## 6. Condenser Thermistor Malfunction Alarm (E9)

If the control board detects an open condenser thermistor, "E9" is displayed. When the control board detects a shorted condenser thermistor, a 10-minute delay timer begins. After the 10-minute delay timer expires, "E9" is displayed. To bypass the 10-minute delay timer, move the power switch to the "OFF" position. Then, while pressing the rail "SET" button, move the power switch to the "ON" position.

- If this alarm appears, first make sure that the thermistor is properly connected to the control board.
- A shorted condenser thermistor is not detected by the control board during the 1st hour after power is turned on. To bypass the 1-hour delay timer, move the power switch to the "OFF" position. Then, while pressing the rail "SET" button, move the power switch to the "ON" position.

### Reset Options

The "E9" alarm automatically resets when one of the following conditions is met:

- The condenser thermistor is secured to the control board.
- The condenser thermistor is within normal operating range. For details, see "II. E. Thermistor Check."
- A functioning condenser thermistor is installed.

### Possible Causes

- Trouble with the condenser thermistor. For checkout procedure, see "II.E. Thermistor Check."
- Trouble with the control board reading the condenser thermistor.

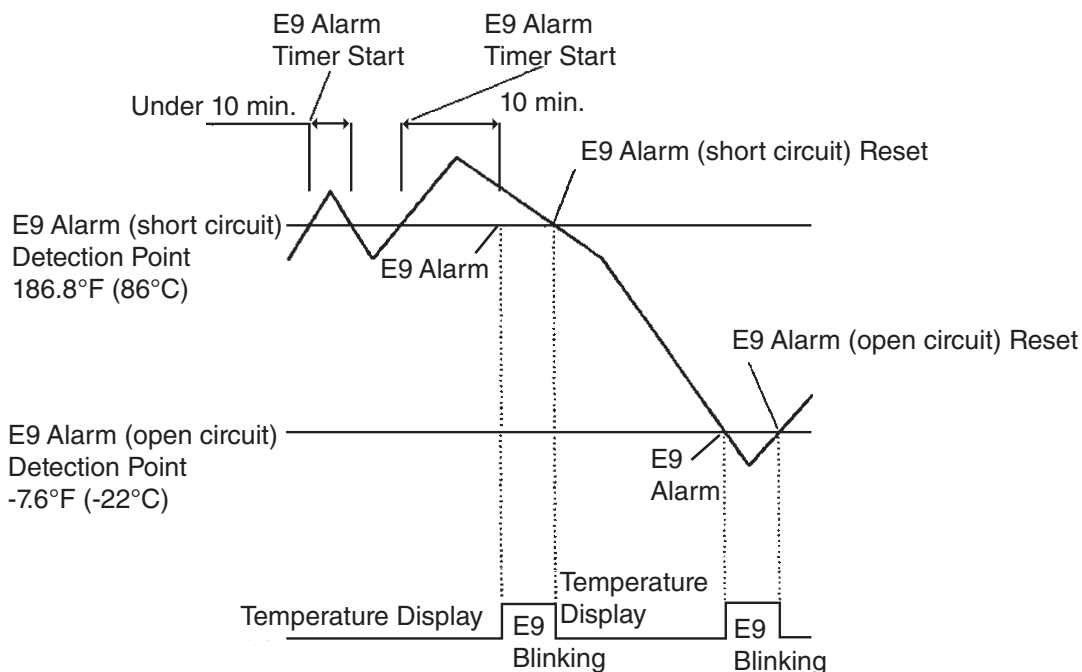

## 7. Control Board Alarms (EA and ED)

"EA" is displayed when an EEPROM write error is detected. "ED" is displayed when an EEPROM verification or read error is detected.

### Reset Options

Replacing the control board with a functioning control board will eliminate this alarm condition.

## B. Service Chart

### 1. No Operation

Problem	Possible Cause	Remedy	
[1] The unit will not start.	a) Power Supply	1. Unplugged, off, blown fuse, or tripped or defective circuit breaker.	1. Turn on, replace, or check and reset. Call electrician if breaker trips repeatedly.
		2. Loose connection.	2. Tighten.
		3. Not within specifications.	3. Refer to nameplate and correct.
	b) Cord and Plug	1. Defective.	1. Replace.
	c) Control Switch	1. "OFF" position.	1. Move to "ON" position.
		2. Bad contacts.	2. Check for continuity and replace.
	d) Transformer	1. Open coil winding.	1. Check continuity and replace.
e) Wiring to Control Board	1. Loose connections or open.	1. Check for continuity and replace.	
f) Control Board	1. In alarm.	1. See "III.A. Alarm Signals."	
	2. Defective.	2. Replace.	
[2] Cabinet, rail, or condenser fan will not start.	a) Fan Motor	1. Motor winding open.	1. Replace.
		2. Bearing worn out.	2. Replace.
		3. Wiring to fan motor.	3. Check for loose or open connection, and replace.
		4. Fan blade bound.	4. Check and replace.
	b) Evaporator Fan, Rail Fan, or Compressor Relay	1. Bad contacts.	1. Check for continuity and replace.
		2. Coil winding open.	2. Replace.
c) Control Board	1. Defective.	1. Replace.	
[3] Compressor will not start or stops operating.	a) Compressor Relay	1. Bad contacts.	1. Check for continuity and replace.
	b) Compressor Control Relay	1. Bad contacts.	1. Check for continuity and replace.
		2. Open winding.	2. Replace.
	c) Start Relay	1. Bad contacts.	1. Replace.
		2. Coil winding open.	2. Replace.
	d) Start Capacitor	1. Defective.	1. Check and replace.
	e) Wiring to Compressor	1. Loose connection(s).	1. Tighten.
2. Faulty.		2. Check continuity and replace.	

Problem	Possible Cause	Remedy	
[3] Compressor will not start or stops operating. (continued)	f) Voltage	1. Too low.	1. Call electrician.
		2. Too high.	2. Call electrician.
	g) High Pressure Switch	1. Restricted air flow to condenser.	1. Move unit or increase ventilation.
		2. Condenser air filter and/or condenser clogged.	2. Clean.
		3. Bad contacts.	3. Check continuity and replace.
		4. Condenser fan motor.	4. See [2] a) and b).
	g) High Pressure Switch (continued)	5. Refrigerant line or component plugged or restricted.	5. Recover, remove restriction, replace drier, evacuate, and recharge.
		6. Refrigerant overcharge.	6. Recover, evacuate, and recharge.
		7. Non-condensibles in system.	7. Recover, replace drier, evacuate, and recharge.
	h) Thermistors (cabinet and rail)	1. Defective.	1. See "II.E. Thermistor Check."
	i) Compressor Overload	1. Defective. (open contacts)	1. Replace.
	j) Compressor	1. Open windings.	1. Check for continuity and replace.
		2. Locked rotor.	2. Replace.
	k) Control Board	1. In alarm or defective.	1. See "III.A. Alarm Signals" or replace

## 2. Cabinet Cooling

Problem	Possible Cause	Remedy	
[1] Cabinet temperature too high.	a) Warm Food	1. Warm food recently placed in cabinet area.	1. Pre-cool food or allow time for unit to return to setpoint temperature.
	b) Doors/Drawers	1. Left open, opened too often.	1. Close.
		2. Not sealing, opened frequently, or open for long intervals.	2. Check for sealing, check for door open at time of warm cabinet temperature.
	c) Outside Heat Source	1. Too close to unit.	1. Separate unit from heat source.
	d) Air Flow	1. Blockage inside cabinet.	1. Remove blockage by removing or redistributing food product.
	e) Cabinet Thermistor	1. Defective.	1. See "II.E. Thermistor Check."
f) Setpoint and/or Temperature Correction Factor	1. Incorrect.	1. Correct setting(s). See "II.D.4.c) Temperature Setpoint" or "II.D.4.f) Temperature Correction Factor" for defaults.	

<b>Problem</b>	<b>Possible Cause</b>		<b>Remedy</b>
[1] Cabinet temperature too high. (continued)	g) Defrost	1. Defrost time insufficient to remove frost. Operation in humid conditions.	1. See "4. Cabinet Defrost."
		2. Incomplete defrost.	2. See "4. Cabinet Defrost."
	h) Air Filter or Condenser	1. Clogged, dirty.	1. Clean.
	i) Cabinet Fan Motor	1. Defective.	1. Check and replace.
	j) Cabinet Liquid Line Valve	1. Does not open.	1. Check and replace.
	k) Service Valve(s)	1. Partially or completely closed.	1. Confirm service valve is open.
	l) Refrigerant	1. Leak.	1. Recover, repair leak, replace drier, evacuate, and recharge.
	m) Expansion Valve	1. Operating erratically.	1. Check and replace.
	n) Compressor	1. Defective.	1. See "1.[3] Compressor will not start or stops operating."
	o) Control Board	1. Defective.	1. Replace.
[2] Cabinet temperature too low.	a) Setpoint and/or Temperature Correction Factor	1. Incorrect.	1. Correct setting(s). See "II.D.4.c) Temperature Setpoint" or "II.D.4.f) Temperature Correction Factor" for defaults.
	b) Frozen Food	1. Frozen food recently placed in refrigerator.	1. Allow time for unit to return to setpoint temperature.
	c) Cabinet Thermistor	1. Defective.	1. Check and replace.
	d) Cabinet Liquid Line Valve	1. Does not close.	1. Check and replace.
	e) Compressor Relay	1. Defective; contacts welded.	1. Replace.
	f) Control Board	1. In alarm or defective.	1. See "III.A Alarm Signals" or replace.

### 3. Rail Cooling

Problem	Possible Cause	Remedy	
[1] Rail temperature too high.	a) Warm Food	1. Warm food recently placed in rail area.	1. Pre-cool food or allow time for unit to return to setpoint temperature.
	b) Rail Pans/Dividers	1. Missing, not in place.	1. Replace. Pans must cover entire rail for proper cooling.
	c) Outside Heat Source	1. Too close to unit.	1. Separate unit from heat source.
	d) Rail Switch	1. "OFF" position.	1. Move to "NORMAL" or "LOW" position.
		2. Bad contacts.	2. Check for continuity and replace.
	e) Rail Thermistor	1. Defective.	1. See "II.E. Thermistor Check."
	f) Setpoint and/or Temperature Correction Factor	1. Incorrect.	1. Correct setting(s). See "II.D.4.c) Temperature Setpoint" or "II.D.4.f) Temperature Correction Factor" for defaults.
	g) Air Filter or Condenser	1. Clogged, dirty.	1. Clean.
	h) Rail Liquid Line Valve	1. Does not open.	1. Check and replace.
	i) Service Valve(s)	1. Partially or completely closed.	1. Confirm service valve is open.
	j) Refrigerant	1. Leak.	1. Recover, repair leak, replace drier, evacuate, and recharge.
	k) Expansion Valve	1. Operating erratically.	1. Check and replace.
	l) Compressor	1. Defective.	1. See "1.[3] Compressor will not start or stops operating."
m) Control Board	1. Defective.	1. Replace.	
[2] Rail temperature too low.	a) Setpoint and/or Temperature Correction Factor	1. Incorrect.	1. Correct setting(s). See "II.D.4.c) Temperature Setpoint" or "II.D.4.f) Temperature Correction Factor" for defaults.
	b) Frozen Food	1. Frozen food recently placed in refrigerator.	1. Allow time for unit to return to setpoint temperature.
	c) Rail Thermistor	1. Defective.	1. Check and replace.
	d) Rail Liquid Line Valve	1. Does not close.	1. Check and replace.
	e) Rail Fan Motor	1. Defective.	1. Check and replace.
	f) Control Board	1. Defective.	1. Replace.

#### 4. Cabinet Defrost

Problem	Possible Cause		Remedy
[1] Cabinet fan motors on.	a) Cabinet Fan Relay	1. Bad contacts (closed).	1. Check for continuity and replace.
	b) Control Board	1. Defective.	1. Replace.
[2] Evaporator does not defrost completely.	a) Defrost Thermistor	1. Defective.	1. See "II.E. Thermistor Check."
	b) Defrost	1. Not enough defrosts occurring per day. Operation in humid conditions.	1. Factory default is once every 6 hours. See "II.D.5. Service Menu."
	c) Defrost Heater	1. Defective.	1. Replace heater.
	d) Defrost Thermostat	1. Defective, turning off heaters prematurely, or fused open.	1. Replace defrost thermostat.
	e) Cabinet Liquid Line Valve	1. Does not close.	1. Check and replace.
[3] Defrost cycle too long. (E3 Defrost Alarm)	a) Defrost	1. Not enough defrosts occurring per day. Operation in humid conditions.	1. Factory default is once every 6 hours. See "II.D.5 Service Menu."
	b) Defrost Thermistor	1. Defective.	1. Replace.
	c) Defrost Heater	1. Defective.	1. Replace heater.
	d) Defrost Thermostat	1. Defective, turning off heaters prematurely, or fused open.	1. Replace defrost thermostat.
	e) Control Board	1. Defective.	1. Replace.

## 5. Other

Problem	Possible Cause	Remedy	
[1] Condensate water overflow.	a) Cabinet Contents	1. Loading large volumes of warm, moist, uncovered product.	1. Pre-cool food. Cover product with plastic wrap.
	b) Location of Unit	1. Unit located near high humidity source such as fryer, steamer, etc.	1. Relocate.
	c) Seals	1. Poor sealing around evaporator, door/drawer gaskets.	1. Adjust or replace.
	d) Environment	1. Extreme environment and door-opening conditions.	1. Adjust conditions.
	e) Rail Condensate Pan	1. Overflowing.	1. Empty and clean rail condensate pan.
[2] Abnormal Noise	a) Fasteners	1. Loose fasteners allow vibration of part.	1. Tighten fasteners.
	b) Compressor	1. Problem with mount.	1. Properly mount compressor. Replace any missing grommets.
		2. Floodback to compressor.	2. Check for signs of floodback to compressor. Recover, evacuate, and recharge if necessary.
		3. Defective.	3. Replace.
	c) Fan	1. Fan blade loose.	1. Adjust and tighten.
		2. Defective motor.	2. Replace.
	d) Relay	1. Chattering.	1. Replace.
e) Liquid Line Valve Solenoid	1. Loose.	1. Tighten.	

---

## IV. Removal and Replacement of Components

### ⚠ WARNING

1. This unit should be diagnosed and repaired only by qualified service personnel to reduce the risk of death, electric shock, serious injury, or fire.
2. Move the power switch to the "OFF" position and unplug the unit before servicing.
3. Make sure all food zones are clean after the unit is serviced. For cleaning procedures, see "V. Cleaning and Maintenance Instructions."

### A. Service for Refrigerant Lines

#### ⚠ WARNING

1. Repairs requiring the refrigeration circuit to be opened must be performed by properly trained and EPA-certified service personnel.
2. Always recover the refrigerant and store it in an approved container. Do not discharge the refrigerant into the atmosphere.
3. Use an electronic leak detector or soap bubbles to check for leaks. Add a trace of refrigerant to the system (if using an electronic leak detector), and then raise the pressure using nitrogen gas (140 PSIG). DO NOT use R-404A as a mixture with pressurized air for leak testing.

#### CAUTION

1. The Polyol Ester (POE) oils used in R-404A units can absorb moisture quickly. Therefore it is important to prevent moisture from entering the system when replacing or servicing parts.
2. Always install a new drier every time the sealed refrigeration system is opened.
3. Do not replace the drier until after all other repair or replacement has been made. Install the new drier with the arrow on the drier in the direction of the refrigerant flow.
4. When brazing, protect the drier by using a wet cloth to prevent the drier from overheating. Do not allow the drier to exceed 250°F (121°C).
5. Do not leave the system open for longer than 15 minutes when replacing or servicing parts.

### 1. Refrigerant Recovery

The unit is provided with a receiver service valve, and compressor and rail access valves. Using proper refrigerant practices, recover the refrigerant from the receiver service valve and compressor access valve and store it in an approved container. Do not discharge the refrigerant into the atmosphere.

Note: Attach the high-side gauge manifold hose to the receiver service valve before opening the receiver service valve.

## 2. Brazing

### ▲ WARNING

1. R-404A itself is not flammable at atmospheric pressure and temperatures up to 176°F (80°C).
2. R-404A itself is not explosive or poisonous. However, when exposed to high temperatures (open flames), these refrigerants can be decomposed to form hydrofluoric acid and carbonyl fluoride both of which are hazardous.
3. Do not use silver alloy or copper alloy containing arsenic.
4. Use an electronic leak detector or soap bubbles to check for leaks. Add a trace of refrigerant to the system (if using an electronic leak detector), and then raise the pressure using nitrogen gas (140 PSIG). DO NOT use R-404A as a mixture with pressurized air for leak testing.

- 1) Braze all fittings while purging with nitrogen gas flowing at a pressure of 3 to 4 PSIG.  
Note: Because the pipes in the evaporator case are specially coated to resist corrosion, it is important to make connections outside the evaporator case when possible. If it is necessary to braze inside the evaporator case, use sandpaper to remove the coating from the brazing connections before unbrazing the components.

### CAUTION

1. Always install a new drier every time the sealed refrigeration system is opened.
2. Do not replace the drier until after all other repair or replacement has been made. Install the new drier with the arrow on the drier in the direction of the refrigerant flow.
3. When brazing, protect the drier by using a wet cloth to prevent the drier from overheating. Do not allow the drier to exceed 250°F (121°C).

- 2) Use an electronic leak detector or soap bubbles to check for leaks. Add a trace of refrigerant to the system (if using an electronic leak detector), and then raise the pressure using nitrogen gas (140 PSIG). DO NOT use R-404A as a mixture with pressurized air for leak testing.

## 3. Evacuation and Recharge (R-404A)

- 1) Attach a vacuum pump to the system. Be sure to connect the gauge manifold hoses to the receiver service valve (high-side) and the compressor access valve (low-side). For high-side system access, run in the receiver service valve stem a couple of turns.

### IMPORTANT

The vacuum pump may be the same as those for current refrigerants. However, the rubber hose and gauge manifold to be used for evacuation and refrigerant charge should be exclusively for POE oils.

- 2) Turn on the vacuum pump. Open the gauge manifold valves. Never allow the oil in the vacuum pump to flow backwards.

- 3) Allow the vacuum pump to pull down to a 29.9" Hg vacuum. Evacuating period depends on pump capacity.
- 4) Close both gauge manifold valves.
- 5) Turn off the vacuum pump. Disconnect the vacuum pump hose and attach it to a refrigerant service cylinder. Remember to loosen the connection, and purge the air from the hose. See the nameplate for the required refrigerant charge. Hoshizaki recommends only virgin refrigerant or reclaimed refrigerant which meets ARI Standard No. 700 (latest edition) be used.
- 6) A liquid charge is recommended for charging an R-404A system. Invert the service cylinder and place it on scales.
- 7) Open the high-side gauge manifold valve and allow the system to charge with liquid until the proper charge is met.
- 8) If necessary, add any remaining charge to the system through the compressor access valve. Use a throttling valve or liquid dispensing device to add the remaining liquid charge through the compressor access valve with the unit running.
- 9) Back out the receiver service valve stem all the way and tighten. Disconnect the gauge manifold hoses.  
 Note: Be sure the receiver service valve stem is backseated all the way out and tight before disconnecting the gauge manifold hose.
- 10) Cap the valves to prevent possible leaks.

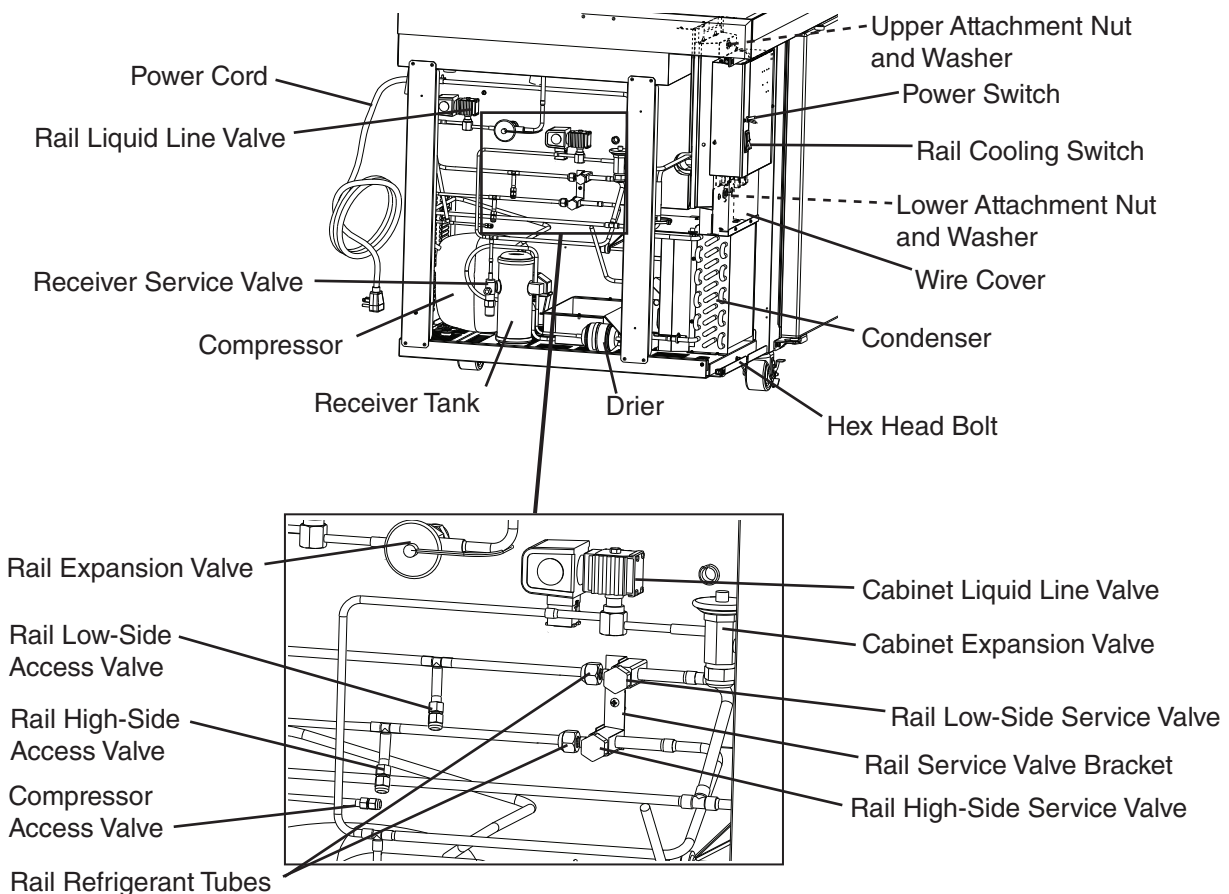

**Fig. 1**

## B. Removal and Replacement of Refrigeration System Cartridge

### CAUTION

The refrigeration system cartridge should not be removed until the refrigerant has been properly recovered or the refrigeration system has been properly pumped down. For refrigeration system repairs, the refrigerant recovery procedure must be used. See "IV.B.1. Refrigerant Recovery Procedure." For non-refrigeration system repairs, see "IV.B.2. Pump-Down Procedure." Do not discharge the refrigerant into the atmosphere.

### 1. Refrigerant Recovery Procedure

- 1) Remove the front panel. Move the power switch to the "OFF" position, then unplug the unit.
- 2) Remove the left side panel.
- 3) Connect the gauge manifold hoses to the receiver service valve (high-side) and the compressor access valve (low-side). See Fig. 1.
- 4) Run in the receiver service valve stem a couple of turns for high-side system access.  
Note: Be sure the high-side gauge manifold hose is on the receiver service valve before opening the receiver service valve.
- 5) Using proper refrigerant practices, recover the refrigerant and store it in an approved container. Do not discharge the refrigerant into the atmosphere.
- 6) When the recovery is finished, close the gauge manifold valves and back out the receiver service valve stem all the way and tighten.  
Note: Be sure the receiver service valve stem is backseated all the way out and tight.
- 7) Close the rail high and low-side service valves. Run in the rail service valve stems all the way until tight.  
Note: Be sure the rail high and low-side service valve stems are seated all the way in and tight.
- 8) Disconnect the rail refrigerant tubes from the rail service valves. Use a backup wrench when loosening the fittings. See Fig. 1.
- 9) Remove the screw securing the rail service valve bracket.
- 10) Disconnect the power supply cord connector, rail thermistor connector, and the perimeter heater/rail fan motor connector.
- 11) Remove the wire cover below the control box.
- 12) Remove the upper and lower attachment nuts and washers from the control box and the hex head bolt from the base of the refrigeration cartridge. See Fig. 1.

- 13) Slide the refrigeration cartridge forward. Support the evaporator as it clears the evaporator case. See Fig. 2.

### **CAUTION**

1. Be careful when handling the cabinet evaporator assembly. This assembly includes a defrost heater sheathed in a glass tube. This sheathing can be easily damaged and may also cause cuts if broken. The defrost heater will also be hot after a defrost. Use gloves when handling and avoid touching the glass directly. Also prevent the defrost heater from touching other parts.
2. To avoid refrigerant leaks, be sure to prevent the refrigeration piping from coming into contact with the frame when removing and replacing the refrigeration cartridge.

- 14) Once the repair is made, replace the refrigeration cartridge back into its correct position. Support the cabinet evaporator as it enters the cabinet evaporator case.
- 15) Reconnect the rail refrigerant tubes. Use a backup wrench and tighten the fittings 1/6 turn beyond fully seated. Be sure to use a backup wrench when tightening the fittings.
- 16) Secure the rail service valve bracket back in its correct position.
- 17) Secure the refrigeration cartridge with the attachment nuts, washers, and the hex head bolt.
- 18) Replace the wire cover and panels in their correct positions.
- 19) Open the rail high and low-side service valves. Back out the rail service valve stems all the way to their original position and tighten.  
Note: Be sure the rail high and low-side service valve stems are backseated all the way out and tight.
- 20) Run in the receiver service valve stem a couple of turns for high-side system access.  
Note: Be sure the high-side gauge manifold hose is on the receiver service valve before opening the receiver service valve.
- 21) Use an electronic leak detector or soap bubbles to check for leaks. Add a trace of refrigerant to the system (if using an electronic leak detector), and then raise the pressure using nitrogen gas (140 PSIG). DO NOT use R-404A as a mixture with pressurized air for leak testing.
- 22) Evacuate the system. Then, charge the system with refrigerant; see the nameplate for the required refrigerant charge.
- 23) Back out the receiver service valve stem all the way and tighten, then close both gauge manifold valves.  
Note: Be sure the receiver service valve stem is backseated all the way out and tight.
- 24) Cap the valves to prevent a possible leak.
- 25) Reconnect the power supply cord connector, rail thermistor connector, and perimeter heater/rail fan motor connector.
- 26) Plug the unit back in, then move the power switch to the "ON" position to start the unit's cooling process.

## 2. Refrigeration System Pump-Down Procedure

- 1) Remove the front panel. Move the power switch to the "OFF" position, then unplug the unit.
- 2) Remove the left side panel.
- 3) Connect the gauge manifold hoses to the receiver service valve (high-side) and the rail low-side access valve. See Fig. 1.  
Note: Be sure the high-side gauge manifold hose is on the receiver service valve before opening the receiver service valve.
- 4) Run in the receiver service valve stem all the way until tight.  
Note: Be sure the receiver service valve stem is seated all the way in and tight.
- 5) Plug the unit back in, then move the power switch to the "ON" position.
- 6) Move the rail switch to the "NORMAL" position. There is a 2-minute delay before the compressor starts. Once the compressor starts, the system pump-down begins.
- 7) When the low-side gauge indicates a vacuum, close the high and low-side rail service valves completely. Run in the rail service valve stems all the way until tight.  
Note: Be sure the rail high and low-side service valve stems are seated all the way in and tight.
- 8) Move the power switch to the "OFF" position, then unplug the unit.
- 9) Back out the receiver service valve stem all the way until fully seated. Remove the high-side gauge manifold hose.  
Note: Be sure the receiver service valve stem is backseated all the way out and tight.
- 10) Use a backup wrench and disconnect the rail refrigerant tubes from the rail high and low-side service valves. Use a backup wrench when loosening the fittings. See Fig. 1.
- 11) Remove the screw securing the rail service valve bracket.
- 12) Disconnect the power supply cord connector, rail thermistor connector, and perimeter heater/rail fan connector.
- 13) Remove the wire cover below the control box.
- 14) Remove the upper and lower attachment nuts and washers from the control box and the hex head bolt from the base of the refrigeration system cartridge. See Fig. 1.
- 15) Slide the refrigeration cartridge forward. Support the evaporator as it clears the evaporator case. See Fig. 2.

### CAUTION

1. Be careful when handling the cabinet evaporator assembly. This assembly includes a defrost heater sheathed in a glass tube. This sheathing can be easily damaged and may also cause cuts if broken. The defrost heater will also be hot after a defrost. Use gloves when handling and avoid touching the glass directly. Also prevent the defrost heater from touching other parts.
2. To avoid refrigerant leaks, be sure to prevent the refrigeration piping from coming into contact with the frame when removing and replacing the refrigeration cartridge.

- 16) Once the repair is made, replace the refrigeration cartridge back into its correct position. Support the cabinet evaporator as it enters the cabinet evaporator case.
- 17) Reconnect the rail side refrigerant tubes. Use a backup wrench and tighten the fittings 1/6 turn beyond fully seated. Use a backup wrench when tightening the fittings.
- 18) Secure the rail service valve bracket back in its correct position.
- 19) Secure the refrigeration cartridge with the attachment nuts, washers, and the hex head bolt.
- 20) Replace the wire cover and panels in their correct positions.
- 21) Connect the high-side gauge manifold hose to the rail high-side access valve.
- 22) Use an electronic leak detector or soap bubbles to check for leaks. Add a trace of refrigerant to the system (if using an electronic leak detector), and then raise the pressure using nitrogen gas (140 PSIG). DO NOT use R-404A as a mixture with pressurized air for leak testing
- 23) Evacuate the rail system. Close the gauge manifold valves.
- 24) Open the rail high and low-side service valves. Back out the rail high and low-side service valve stems all the way until fully seated.  
Note: Be sure the rail high and low-side service valve stems are backseated all the way out and tight.
- 25) Remove the gauge manifold hoses.
- 26) Cap the valves to prevent possible refrigerant leaks.
- 27) Use an electronic leak detector or soap bubbles to check the rail refrigerant connections for refrigerant leaks.
- 28) Reconnect the power supply cord connector, rail thermistor connector, and the perimeter heater/rail fan connector.
- 29) Plug the unit back in, then move the power switch to the "ON" position to start the unit's cooling process.

Fig. 2

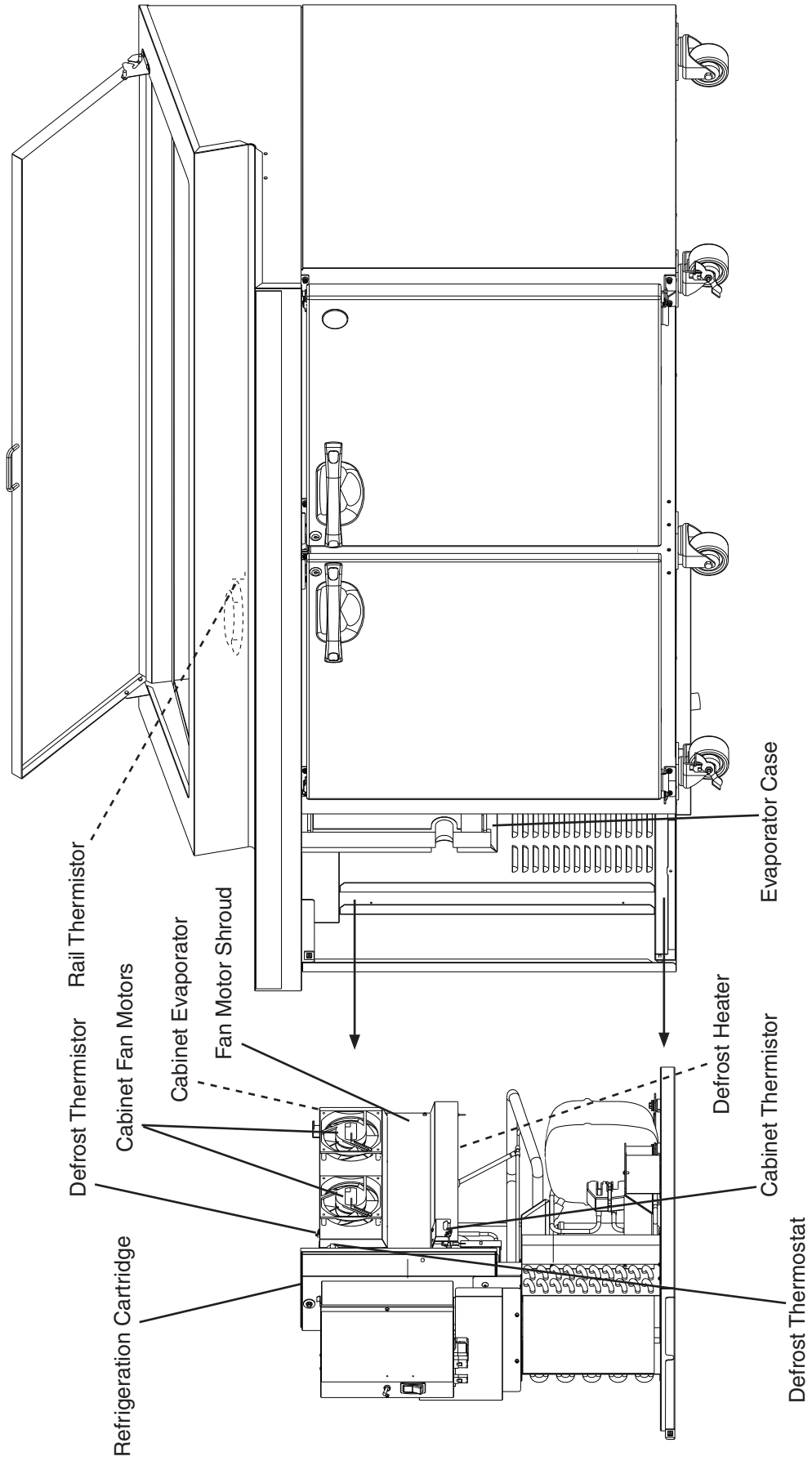

## C. Removal and Replacement of Compressor

### CAUTION

1. Always install a new drier every time the sealed refrigeration system is opened.
2. Do not replace the drier until after all other repair or replacement has been made. Install the new drier with the arrow on the drier in the direction of the refrigerant flow.
3. When brazing, protect the drier by using a wet cloth to prevent the drier from overheating. Do not allow the drier to exceed 250°F (121°C).
4. Recover the refrigerant when replacing the compressor. Do not discharge the refrigerant into the atmosphere.
5. The compressor may be replaced without removing the refrigeration cartridge. If removing the refrigeration cartridge, see "IV.B. Removal and Replacement of Refrigeration Cartridge."

Note: When replacing a compressor with a defective winding, be sure to install a new start capacitor, overload and start relay. Due to the ability of the POE oil in the compressor to absorb moisture quickly, the compressor must not be opened more than 15 minutes for replacement or service. Do not mix lubricants of different compressors even if both are charged with the same type of refrigerant, except when they use the same lubricant.

- 1) Move the power switch to the "OFF" position, then unplug the unit.
- 2) Remove the front, left side, and rear panels.
- 3) Recover the refrigerant and store it in an approved container.
- 4) Remove the terminal cover on the compressor and disconnect the compressor wiring.
- 5) Remove the discharge, process, and suction pipes.
- 6) Remove the hold-down bolts, washers, rubber grommets, and sleeves.
- 7) Remove the compressor. Unpack the new compressor. Attach the rubber grommets and sleeves of the prior compressor.
- 8) Place the new compressor in position, and secure it using the bolts and washers.
- 9) Remove the drier, then place the new drier in position.
- 10) Remove the plugs from the suction, discharge, and process pipes.
- 11) Braze all fittings while purging with nitrogen gas flowing at a pressure of 3 to 4 PSIG.
- 12) Use an electronic leak detector or soap bubbles to check for leaks. Add a trace of refrigerant to the system (if using an electronic leak detector), and then raise the pressure using nitrogen gas (140 PSIG). DO NOT use R-404A as a mixture with pressurized air for leak testing.
- 13) Evacuate the system, and charge it with refrigerant; see the nameplate for the required refrigerant charge.
- 14) Connect the compressor terminals, then replace the terminal cover in its correct position.

- 15) Replace the panels in their correct positions.
- 16) Plug in the unit, then move the power switch to the "ON" position to start the unit's cooling process.

## D. Removal and Replacement of Cabinet Evaporator

### CAUTION

1. Always install a new drier every time the sealed refrigeration system is opened.
2. Do not replace the drier until after all other repair or replacement has been made. Install the new drier with the arrow on the drier in the direction of the refrigerant flow.
3. When brazing, protect the drier by using a wet cloth to prevent the drier from overheating. Do not allow the drier to exceed 250°F (121°C).

- 1) Remove the refrigeration system cartridge. Perform steps 1 through 14 in "IV.B.1. Recovery Procedure." Once the refrigeration cartridge is out, proceed to step 2.

### WARNING

Be careful when handling the cabinet evaporator assembly. This assembly includes a defrost heater sheathed in a glass tube. This sheathing can be easily damaged and may also cause cuts if broken. The defrost heater will also be hot after a defrost. Use gloves when handling and avoid touching the glass directly. Also prevent the defrost heater from touching other parts.

- 2) Remove the defrost heater, defrost thermostat, defrost and cabinet thermistors from the evaporator. See Fig. 3.
- 3) Remove the evaporator shroud and evaporator bracket from the evaporator.
- 4) Remove the insulation tubing, and disconnect the evaporator inlet and outlet tubing.
- 5) Remove the screws holding the evaporator to the refrigeration system cartridge.
- 6) Remove the evaporator and drier.
- 7) Place the new evaporator and new drier in position. Provide a safe means for supporting the evaporator.

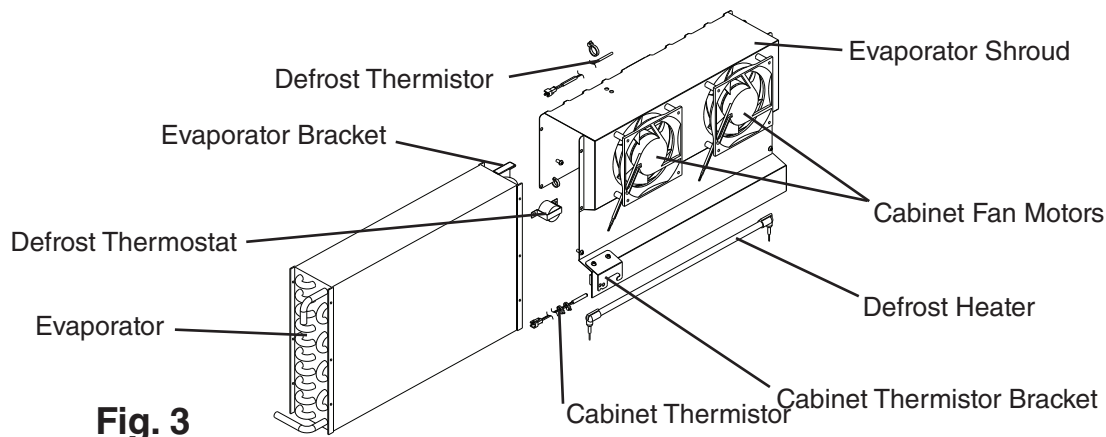

**Fig. 3**

- 8) Braze the fittings while purging with nitrogen gas flowing at a pressure of 3 to 4 PSIG.
- 9) Replace the removed evaporator parts in their correct positions.
- 10) Once the repair is complete, return to step 15 in "IV.B.1. Recovery Procedure" for refrigeration system cartridge replacement.

## **E. Removal and Replacement of Expansion Valve**

Moisture in the refrigeration circuit may exceed drier capacity and freeze up at the expansion valve.

### **CAUTION**

1. Always install a new drier every time the sealed refrigeration system is opened.
2. Do not replace the drier until after all other repair or replacement has been made. Install the new drier with the arrow on the drier in the direction of the refrigerant flow.
3. When brazing, protect the valve body and drier by using wet cloths to prevent the valve body and drier from overheating. Do not allow the valve body or drier to exceed 250°F (121°C).

- 1) Move the power switch to the "OFF" position, then unplug the unit.
- 2) Remove the panels.
- 3) Recover the refrigerant and store it in an approved container.
- 4) Remove the insulation and the expansion valve bulb on the suction line.
- 5) Remove the expansion valve cover and disconnect the expansion valve. Place the new expansion valve in position.
- 6) Remove the drier, then place the new drier in position.
- 7) Braze all fittings while purging with nitrogen gas flowing at a pressure of 3 to 4 PSIG.
- 8) Use an electronic leak detector or soap bubbles to check for leaks. Add a trace of refrigerant to the system (if using an electronic leak detector), and then raise the pressure using nitrogen gas (140 PSIG). DO NOT use R-404A as a mixture with pressurized air for leak testing.
- 9) Evacuate the system and charge it with refrigerant; see the nameplate for the required refrigerant charge.
- 10) Attach the expansion valve bulb to the suction line in the same location as the previous bulb. The bulb should be between the 10 and 2 o'clock position on the tube. Be sure to secure the bulb with the clamp and holder and to insulate it.
- 11) Place the expansion valve cover in position.
- 12) Replace the panels in their correct positions.
- 13) Plug in the unit, then move the power switch to the "ON" position to start the unit's cooling process.

## F. Removal and Replacement of Liquid Line Valve

### CAUTION

1. Always install a new drier every time the sealed refrigeration system is opened.
2. Do not replace the drier until after all other repair or replacement has been made. Install the new drier with the arrow on the drier in the direction of the refrigerant flow.
3. When brazing, protect the valve body and drier by using wet cloths to prevent the valve body and drier from overheating. Do not allow the valve body or drier to exceed 250°F (121°C).

- 1) Move the power switch to the "OFF" position, then unplug the unit.
- 2) Remove the panels.
- 3) Recover the refrigerant and store it in an approved container.
- 4) Remove the bolt and the solenoid.
- 5) Disconnect the valve.
- 6) Place the new valve in position.
- 7) Remove the drier, then place the new drier in position.
- 8) Braze all fittings while purging with nitrogen gas flowing at a pressure of 3 to 4 PSIG.
- 9) Use an electronic leak detector or soap bubbles to check for leaks. Add a trace of refrigerant to the system (if using an electronic leak detector), and then raise the pressure using nitrogen gas (140 PSIG). DO NOT use R-404A as a mixture with pressurized air for leak testing.
- 10) Evacuate the system and charge it with refrigerant; see the nameplate for the required refrigerant charge.
- 11) Cut the leads of the solenoid allowing enough lead length to reconnect using closed end connectors.
- 12) Connect the new solenoid leads.
- 13) Attach the solenoid to the valve body and secure it with the bolt.
- 14) Replace the panels in their correct positions.
- 15) Plug in the unit, then move the power switch to the "ON" position to start the unit's cooling process.

## G. Removal and Replacement of Condenser

### CAUTION

1. Always install a new drier every time the sealed refrigeration system is opened.
2. Do not replace the drier until after all other repair or replacement has been made. Install the new drier with the arrow on the drier in the direction of the refrigerant flow.
3. When brazing, protect the drier by using a wet cloth to prevent the drier from overheating. Do not allow the drier to exceed 250°F (121°C).

- 1) Move the power switch to the "OFF" position, then unplug the unit.
- 2) Remove the panels.
- 3) Remove the refrigeration system cartridge. Perform steps 1 through 14 in "IV.B.1. Recovery Procedure." Once the refrigeration system cartridge is out, proceed to step 4.
- 4) Remove the condenser thermistor (clogged filter).
- 5) Disconnect the condenser inlet and outlet piping.
- 6) Remove the condenser assembly.
- 7) Remove the air guide, evaporator case cover bracket, and condenser shroud (A) from the old condenser and attach it to the new condenser. See Fig. 4.
- 8) Place the new condenser assembly in position.
- 9) Remove the drier, then place the new drier in position.
- 10) Braze all fittings while purging with nitrogen gas flowing at a pressure of 3 to 4 PSIG.
- 11) Replace the condenser thermistor (clogged filter) in its correct position.
- 12) Once the repair is complete, return to step 15 in "IV.B.1. Recovery Procedure" for refrigeration system cartridge replacement.

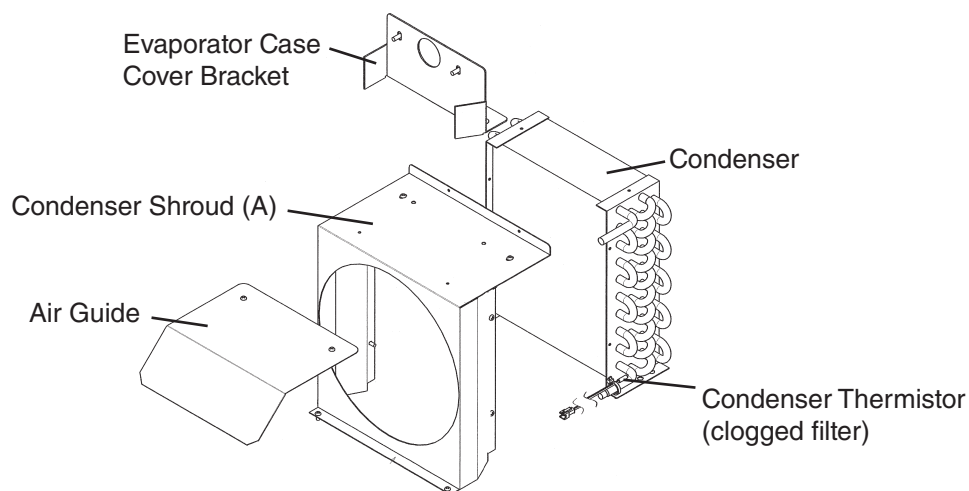

**Fig. 4**

## H. Removal and Replacement of Thermistors and Thermostat

### CAUTION

1. The thermistors are fragile; handle very carefully.
2. Do not shorten or cut the thermistor leads.

#### 1. Cabinet Thermistor

- 1) Remove the refrigeration system cartridge. Perform steps 1 through 16 in "IV.B.2. Pump-Down Procedure." Once the refrigeration system cartridge is out, proceed to step 2.
- 2) Cut the cable tie holding the cabinet thermistor to the cabinet thermistor bracket. Remove the thermistor. See Fig. 5.
- 3) Disconnect the thermistor wire connector (below the control box).
- 4) Install the new thermistor and secure it to the cabinet thermistor bracket. Connect the thermistor connector.
- 5) Once the repair is complete, return to step 17 in "IV.B.2. Pump-Down Procedure" for refrigeration system cartridge replacement.

#### 2. Defrost Thermistor

- 1) Remove the refrigeration system cartridge. Perform steps 1 through 16 in "IV.B.2. Pump-Down Procedure." Once the refrigeration system cartridge is out, proceed to step 2.
- 2) Remove the tape securing the defrost thermistor to the evaporator shroud. Cut the cable tie holding the defrost thermistor to the shroud. Remove the defrost thermistor. See Fig. 5.
- 3) Disconnect the defrost thermistor wire connector (below the control box).
- 4) Install the new defrost thermistor and secure to the evaporator shroud. Connect the defrost thermistor connector.
- 5) Once the repair is complete, return to step 17 in "IV.B.2. Pump-Down Procedure" for refrigeration system cartridge replacement.

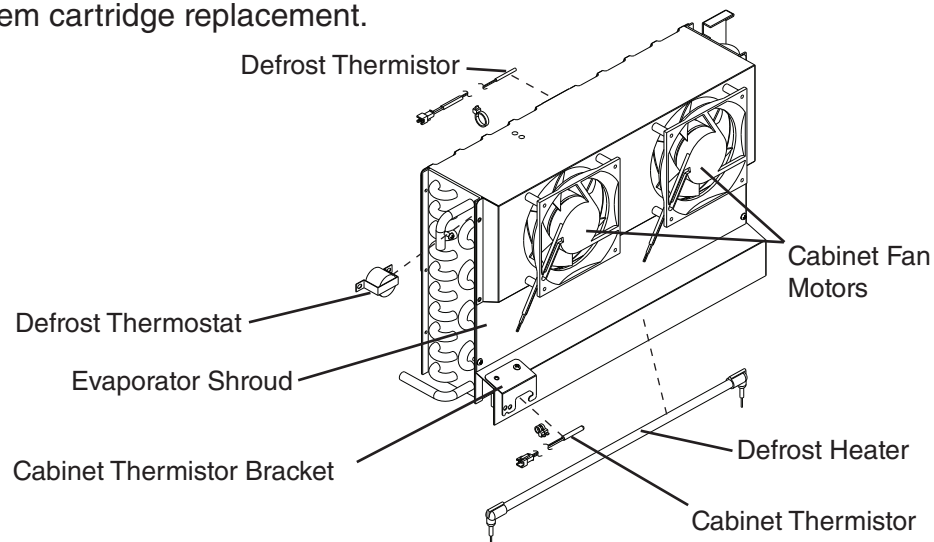

**Fig. 5**

### 3. Defrost Thermostat

- 1) Remove the refrigeration system cartridge. Perform steps 1 through 16 in "IV.B.2. Pump-Down Procedure." Once the refrigeration system cartridge is out, proceed to step 2.
- 2) Disconnect the defrost thermostat wires, then remove the defrost thermostat. See Fig. 5.
- 3) Install the new defrost thermostat and connect the thermostat wires.
- 4) Once the repair is complete, return to step 17 in "IV.B.2. Pump-Down Procedure" for refrigeration system cartridge replacement.

### 4. Rail Thermistor

- 1) Open the front panel. Move the power switch to the "OFF" position, then unplug the unit.
- 2) Remove the storage pans from the rail area. If wet, dry the rail area with a dry cloth.
- 3) Remove the left side rail fan motor shroud. See Fig. 6.
- 4) Cut the ties securing the rail thermistor to the bracket.
- 5) Secure the new thermistor connector to the old thermistor in the rail area. DO NOT cut the new thermistor wire.
- 6) Remove the wire access hole sealant and grommet.
- 7) Push the old thermistor wire (with new thermistor wire securely attached) into the rail channel. Once the new thermistor wire is in the channel, replace the access hole grommet. Remove the left side panel, then pull the thermistor wire through the rail channel.

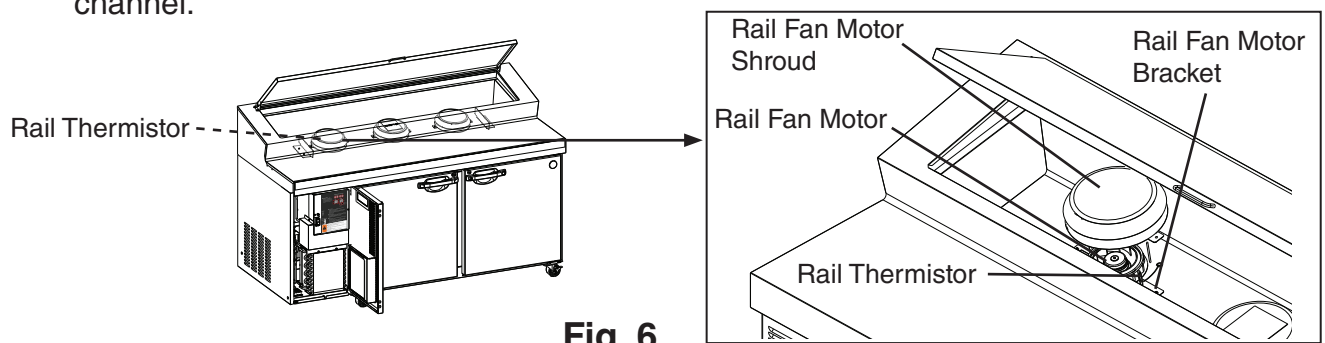

**Fig. 6**

- 8) Disconnect the old thermistor connector from the control box connector, then connect the new thermistor connector to the control box connector.
- 9) Secure the new rail thermistor to the bracket with a cable tie.
- 10) Seal the access hole with food grade silicone.
- 11) Replace the rail fan motor shroud in its correct position and secure. Make sure all wires are clear of the fan.
- 12) Replace the panel and empty storage pans in their correct positions.
- 13) Plug in the unit, then move the power switch to the "ON" position and the rail switch to the "NORMAL" position to start the unit's cooling process.
- 14) Do not place food product in the rail area until the rail section has cooled down.

## 5. Condenser Thermistor (clogged filter)

- 1) Remove the front panel. Move the power switch to the "OFF" position, then unplug the unit.
- 2) Remove the left side panel.
- 3) Remove the aluminum tape and cut the cable tie securing the thermistor. See Fig. 7.
- 4) Remove the thermistor. Disconnect the wire connection (below the control box).
- 5) Install the new thermistor and secure with a cable tie and aluminum tape.
- 6) Plug in the unit, then move the power switch to the "ON" position to start the unit's cooling process.

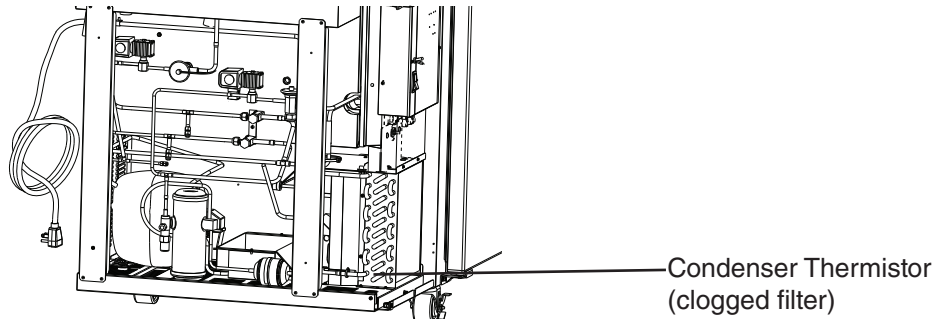

Fig. 7

## I. Removal and Replacement of Defrost Heater

### CAUTION

Be careful when handling both the old and new defrost heaters. The heaters are sheathed in glass tubes and can possibly cause cuts if broken. The heater will also be hot after a defrost. Use gloves when handling. Avoid touching the glass directly; hold the heaters by the ends.

- 1) Remove the refrigeration system cartridge. Perform steps 1 through 16 in "IV.B.2. Pump-Down Procedure." Once the refrigeration system cartridge is out, proceed to step 2.
- 2) Remove the defrost heater from the defrost heater bracket. See Fig. 8.
- 3) Disconnect the defrost heater wires.
- 4) Carefully remove the defrost heater.
- 5) Place the new defrost heater into position.
- 6) Connect the new defrost heater wires.
- 7) Once the repair is complete, return to step 17 in "IV.B.2. Pump-Down Procedure" for refrigeration system cartridge replacement.

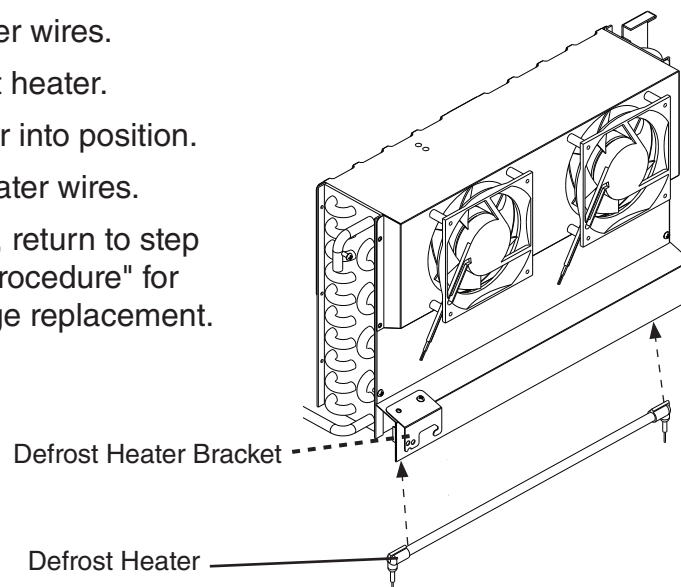

Fig. 8

## J. Removal and Replacement of Fan Motors

### 1. Cabinet Fan Motor

#### CAUTION

Be careful when handling the evaporator shroud assembly. This assembly includes a defrost heater sheathed in a glass tube. This sheathing can be easily damaged and may also cause cuts if broken. Heater will also be hot after a defrost. Use gloves when handling and avoid touching the glass directly. Also prevent heaters from touching other parts.

- 1) Remove the refrigeration system cartridge. Perform steps 1 through 16 in "IV.B.2. Pump-Down Procedure." Once the refrigeration system cartridge is out, return to step 2.
- 2) Disconnect the wires to the fan motor, then remove the defrost thermistor, cabinet thermistor, defrost thermostat, and defrost heater from the evaporator shroud.
- 3) Remove the evaporator shroud from the evaporator.
- 4) Remove the fan motor. See Fig. 9.
- 5) Install the new fan motor.  
Note: Confirm that the fan motor wires are sealed with food grade silicone at the motor housing.
- 6) Replace the evaporator shroud in its proper position.
- 7) Replace the removed parts in their correct positions, and connect the fan motor wires.
- 8) Once the repair is complete, return to step 17 in "IV.B.2. Pump-Down Procedure" for refrigeration system cartridge replacement.

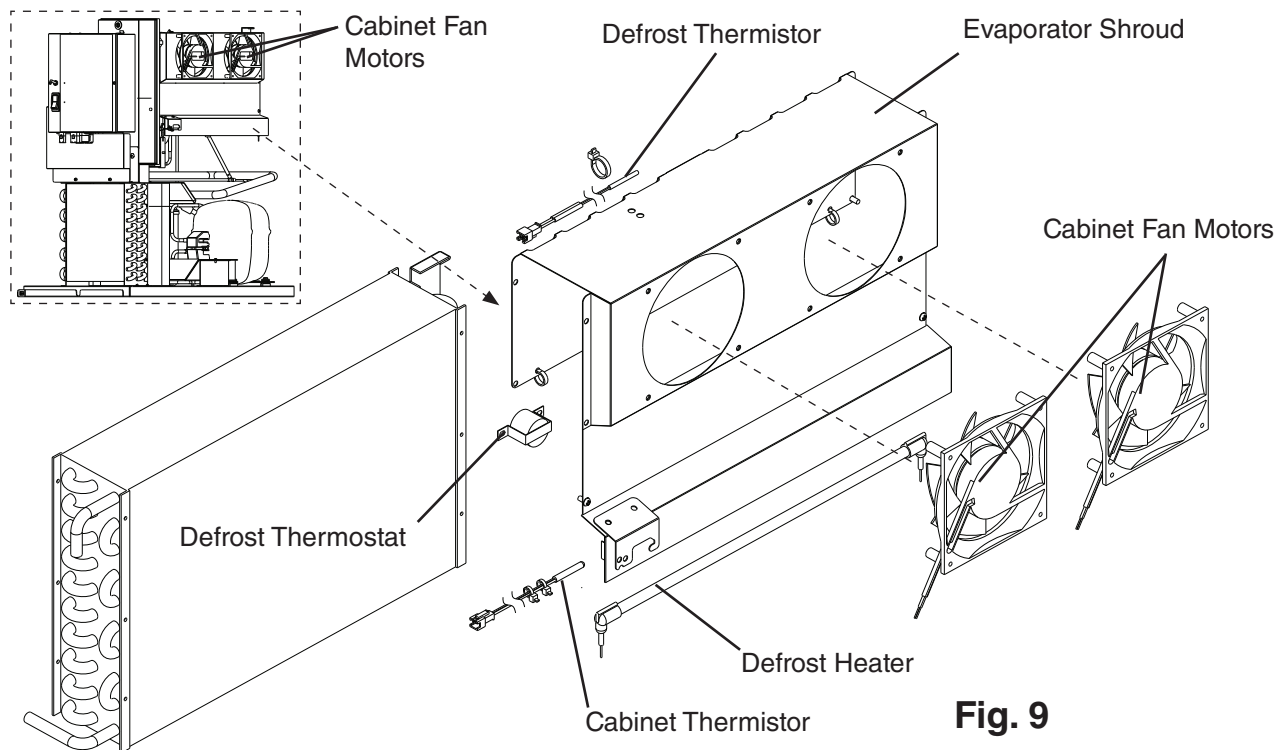

**Fig. 9**

## 2. Condenser Fan Motor

- 1) Open the front panel. Move the power switch to the "OFF" position, then unplug the unit.
- 2) Remove the left side panel.
- 3) Disconnect the fan motor wires.
- 4) Remove the condenser fan motor assembly bolts, then remove the condenser fan motor assembly. See Fig. 10.
- 5) Remove the fan motor from the fan motor bracket and remove the fan blade from the fan motor.
- 6) Place the fan blade on the new fan motor, then install the new fan motor.
- 7) Replace the fan motor assembly in its correct position.
- 8) Connect the fan motor wires.
- 9) Replace the panels in their correct positions.
- 10) Plug in the unit, then move the power switch to the "ON" position to start the unit's cooling process.

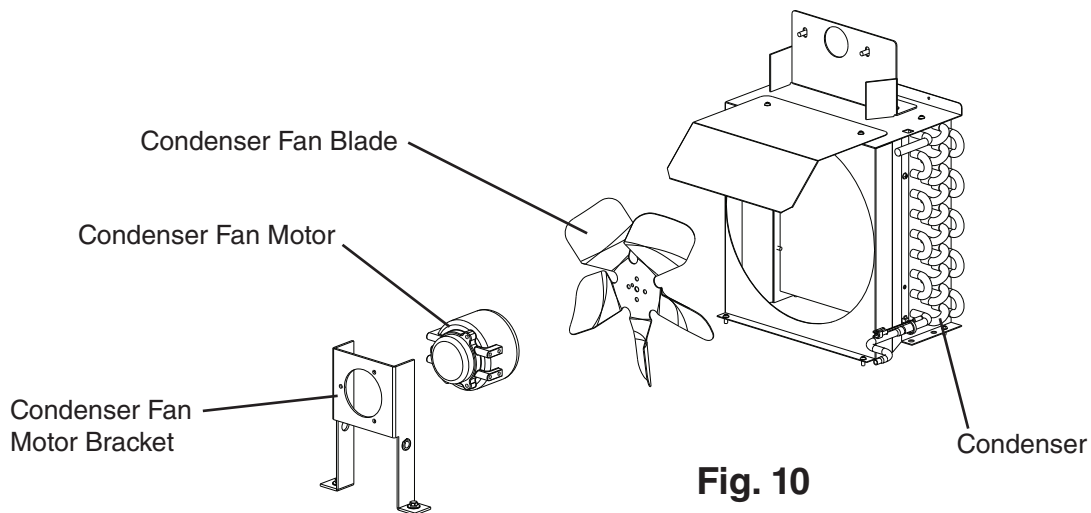

## 3. Rail Fan Motor

- 1) Open the front panel. Move the power switch to the "OFF" position, then unplug the unit.
- 2) Remove the storage pans from the rail area. If wet, dry the rail area with a dry cloth.
- 3) Remove the rail fan motor shroud. See Fig. 11.
- 4) Disconnect the rail fan motor lead wires at least 6" (15 cm) from the fan motor. Remove the rail fan motor and bracket.
- 5) Remove the rail fan motor bracket from the old rail fan motor and place on the new rail fan motor.
- 6) Secure the new fan motor wires to the old fan motor wires in the rail area. DO NOT cut the new fan motor wires.

- 7) Remove the rail access hole sealant and grommet.
- 8) Push the old fan motor wires (with new fan motor wires securely attached) into the rail channel. Once the new fan motor wires are in the channel, replace the access hole grommet. Remove the left side panel, then pull the fan motor wires through the rail channel.
- 9) Disconnect and discard the old fan motor wires. Connect the new fan motor wires.
- 10) Seal the rail access hole with food grade silicone.
- 11) Place the new rail fan motor and the fan motor shroud in their correct positions and secure. Make sure all wires are clear of the fan.
- 12) Replace the panel and empty storage pans in their correct positions.
- 13) Plug in the unit, then move the power switch to the "ON" position and the rail switch to the "NORMAL" position to start the unit's cooling process.
- 14) Do not place food products in the rail area until the rail section has cooled down.

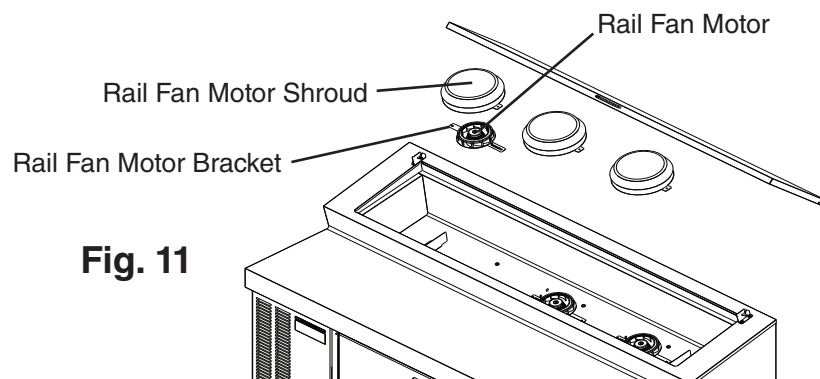

**Fig. 11**

## **K. Removal and Replacement of Door Gasket**

Remove the old gasket by pulling it directly out of the vinyl gasket retainer. Thoroughly clean the gasket area with mild soap and water prior to installing the new gasket. The new gasket should be installed at the corners first, then working toward the center at the top, bottom, and sides. The arrow-shaped portion of the gasket should be firmly seated in the retainer groove for proper assembly. This can be checked by lifting the edge of the gasket and observing the engagement.

### **CAUTION**

In order to get a proper gasket fit, it is important not to stretch gasket material during assembly.

## **L. Door Re-Hinging and Drawer Conversion**

Contact your local Hoshizaki distributor or Hoshizaki Technical Support if door reversing or drawer conversion is desired.

---

## V. Cleaning and Maintenance Instructions

### A. Cleaning

#### WARNING

1. Before cleaning the unit, move the power switch to the "OFF" position and unplug the unit to prevent electric shock by unexpected entrance of water into the unit or injury by moving parts.
2. Before cleaning the unit, move all foods into another clean refrigerator or freezer.
3. Do not splash water directly onto the unit. This might cause short circuit, electric shock, corrosion, or failure.
4. Do not pour or spray water into the rail area. The rail drain is for condensate only. Excessive liquid in the rail area could result in electric shock. Be sure to keep the fans dry.
5. Metal edges can cause cuts. Use care and wear protective gloves when cleaning.
6. Keep hands clear of fan shrouds when the unit is operating. The rotating fans might cause injury.
7. Before using a sanitizer such as inert soap and sodium hypochlorite (chlorine bleach), thoroughly read the manufacturer's instructions on its proper usage.

#### IMPORTANT

1. To prevent damage to the painted or plastic surfaces, do not use the following: thinner, benzine, alcohol, petroleum, soap powder, polishing powder, alkaline cleaner, acid, scouring pad, and especially those strong cleaners for use on a ventilating fan or a cooking range. Also, to prevent corrosion, do not use a chlorine bleach such as sodium hypochlorite on the stainless steel surfaces.
2. Use a clean cloth for cleaning.

### 1. Work Surface

Clean the cutting board as often as necessary to maintain a clean, sanitary work surface. Also clean the worktop space underneath the cutting board as often as necessary to maintain a clean, sanitary surface. After cleaning, be sure to properly secure the cutting board with the brackets on the ends of the worktop. Slide the brackets down onto the cutting board and tighten the screws.

#### WARNING

Make sure the cutting board is secure. Otherwise, the cutting board could come off and cause injury.

## 2. Rail and Rail Cover

Spills and splashes should be wiped up promptly to avoid unpleasant odors. Wipe the interior of the rail and the rail cover regularly with a clean, damp sponge or cloth containing a neutral cleaner. Do not pour or spray water into the rail area.

### **WARNING**

1. Be sure to support the rail cover when cleaning. Otherwise, the rail cover could close suddenly and cause injury.
2. Metal edges can cause cuts. Use care and wear protective gloves when cleaning.

## 3. Exterior

Wipe the exterior occasionally with a clean, soft cloth. Use a damp cloth containing a neutral cleaner to wipe off oil or dirt build up.

## 4. Cabinet Interior

Spills and splashes should be wiped up promptly to avoid unpleasant odors. The cabinet interior should be cleaned periodically with a mild soap or detergent and warm water.

## 5. Door/Drawer Gaskets

Door/drawer gaskets should be cleaned regularly with mild soap and warm water to remove dirt and grease.

## 6. Shelves (if applicable)

Remove and clean regularly.

## 7. Drawers (if applicable)

The drawers can be removed for cleaning either individually or as an entire assembly.

- To remove an individual drawer, first remove all food product from the drawer. Pull the drawer out to its fully extended position and lift up on the handle to disengage the drawer. Before removing the drawer, carefully support the rear and front of the drawer and then slowly remove it from the cabinet.
- To remove the drawer frame assembly, first remove the drawers and then remove the fasteners in the thermal break and in the rear of the cabinet. Carefully slide the frame out of the cabinet, making sure not to damage the thermal break. Reinstall in the reverse order, making sure not to overtighten the screws in the thermal break.
- To remove the drawer slide (center slide containing rollers) for cleaning, rotate the top of the slide away from the frame while the slide is completely inside the cabinet. Drawer slides do not require lubrication, but slides should be kept clean and free of food.  
Note: Drawer slides are dishwasher safe.

## **B. Maintenance**

### **1. Rail Condensate Pan**

The rail condensate pan collects condensate water from the rail. Empty the pan as often as necessary depending on conditions. Clean the pan at least once a month with a clean, damp sponge or cloth containing a neutral cleaner.

### **2. Air Filter**

The plastic mesh air filter (located behind the front panel) removes dirt and dust from the air, and keeps the condenser from getting clogged. As the filter gets clogged, the unit's performance will be reduced. Check the filter at least twice a month. When clogged, use warm water and a neutral cleaner to wash the filter. The filter can be removed by opening the front panel and lifting the filter away from the condenser.

### **3. Condenser**

Check the condenser once a year, and clean if required by following the steps below. More frequent cleaning may be required depending on location.

#### **⚠ WARNING**

1. Before cleaning the condenser, move the power switch to the "OFF" position and unplug the unit to prevent electric shock or injury by moving parts.
2. Before cleaning the condenser, move all foods into another clean refrigerator or freezer.
3. Condenser fins are sharp. Use care when cleaning.

- 1) Remove and clean the air filter.
- 2) Use a brush attachment on a vacuum cleaner to gently clean the condenser fins. Do not use too much force, otherwise the fins could be damaged.
- 3) Replace the air filter in its proper position.

### **4. Power Supply Connection**

If the plug or power cord is damaged, contact a Hoshizaki Certified Service Representative immediately and ask for repairs.

All other maintenance or service on this unit should be performed in accordance with the Hoshizaki Service Manual by a qualified service technician.

## C. Shutdown and Long Storage

### **WARNING**

1. When preparing the unit for long storage, prevent the doors/drawers from closing to reduce the risk of children getting trapped.
2. To reduce the risk of electric shock, do not touch the attachment plug or switches with damp hands.
3. To unplug the unit, be sure to pull the attachment plug and do not jerk the power cord. It could be damaged and cause fire or electric shock.
4. When shutting down the unit for more than one week, move the power switch to the "OFF" position and unplug the unit.
5. Do not plug in/unplug the unit to start/stop operation. Make sure the power switch is in the "OFF" position before plugging in or unplugging the unit to help reduce the risk of electric shock.

- 1) Before shutting down the unit, move food into another refrigerator or freezer.
- 2) Open the front panel and move the power switch to the "OFF" position. The unit will shut down.
- 3) Unplug the unit.
- 4) Close the front panel.

### **IMPORTANT**

When preparing the unit for long storage, perform the cleaning and maintenance operations detailed in "V. Cleaning and Maintenance Instructions."

# VI. Technical Information

## A. Refrigeration Circuit

### 1. HPR46A(-D), HPR72A(-D), HPR100A(-D)

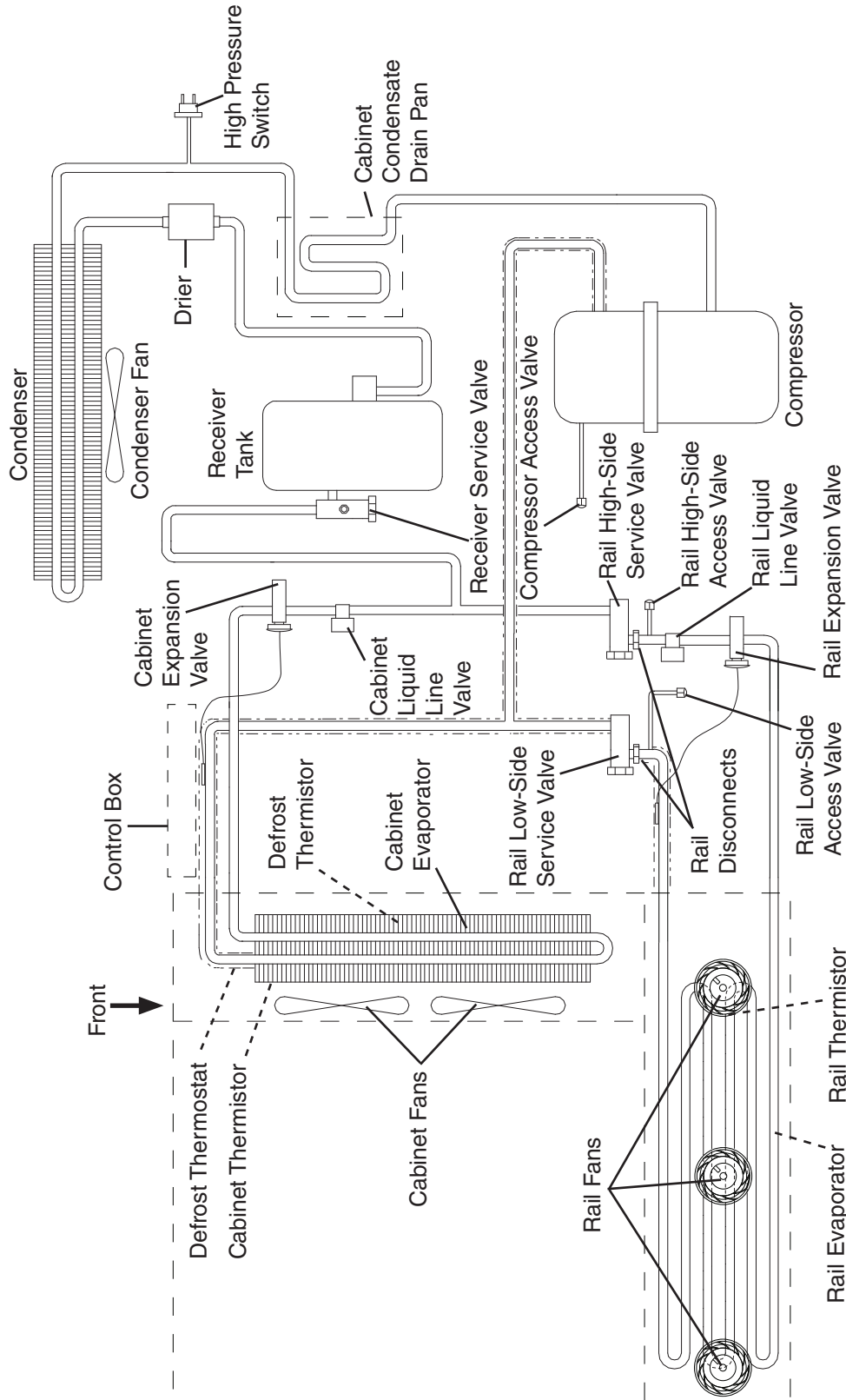

Note: The number of rail fans varies between models.

# B. Wiring Diagrams

## 1. HPR46A(-D)

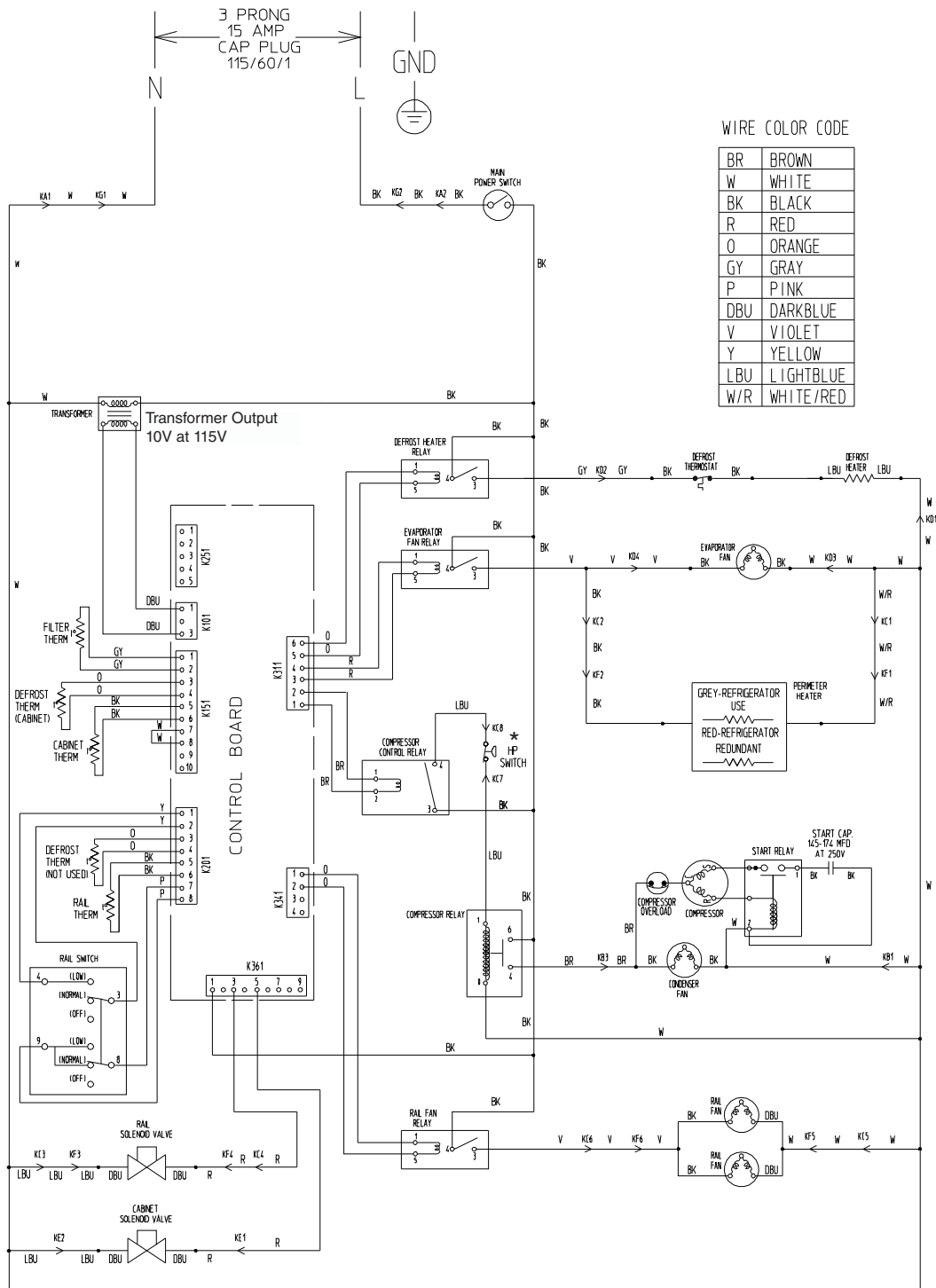

WIRE COLOR CODE

BR	BROWN
W	WHITE
BK	BLACK
R	RED
O	ORANGE
GY	GRAY
P	PINK
DBU	DARKBLUE
V	VIOLET
Y	YELLOW
LBU	LIGHTBLUE
W/R	WHITE/RED

*High Pressure Switch	
Cut-out	490±10 PSIG
Cut-in	370±20 PSIG

## 2a. HPR72A(-D) Auxiliary Code U-5 and Earlier

### WIRE COLOR CODE

BR	BROWN
W	WHITE
BK	BLACK
R	RED
O	ORANGE
GY	GRAY
P	PINK
DBU	DARKBLUE
V	VIOLET
Y	YELLOW
LBU	LIGHTBLUE
W/R	WHITE/RED

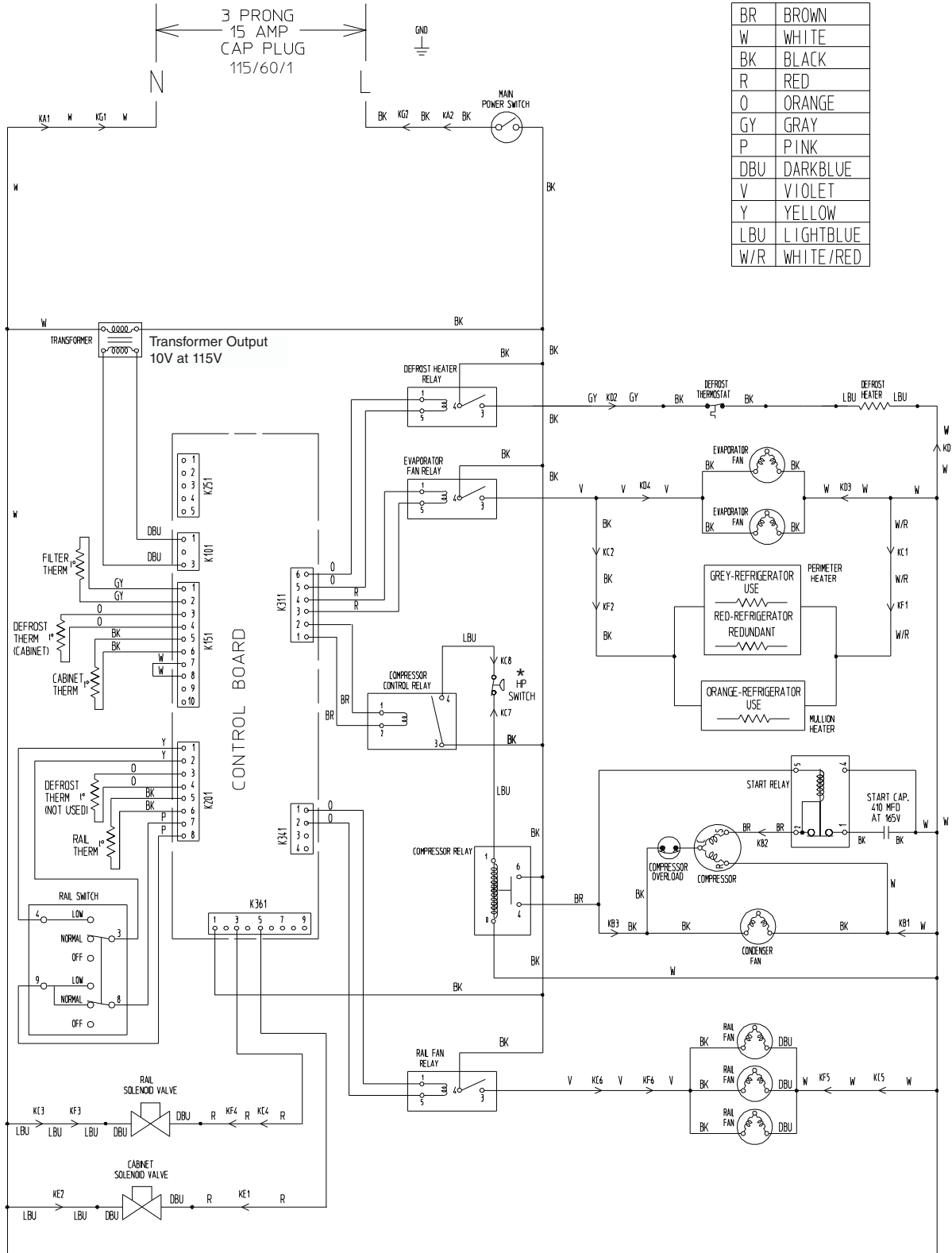

*High Pressure Switch	
Cut-out	490±10 PSIG
Cut-in	370±20 PSIG

## 2b. HPR72A(-D) Auxiliary Code U-6 and Later

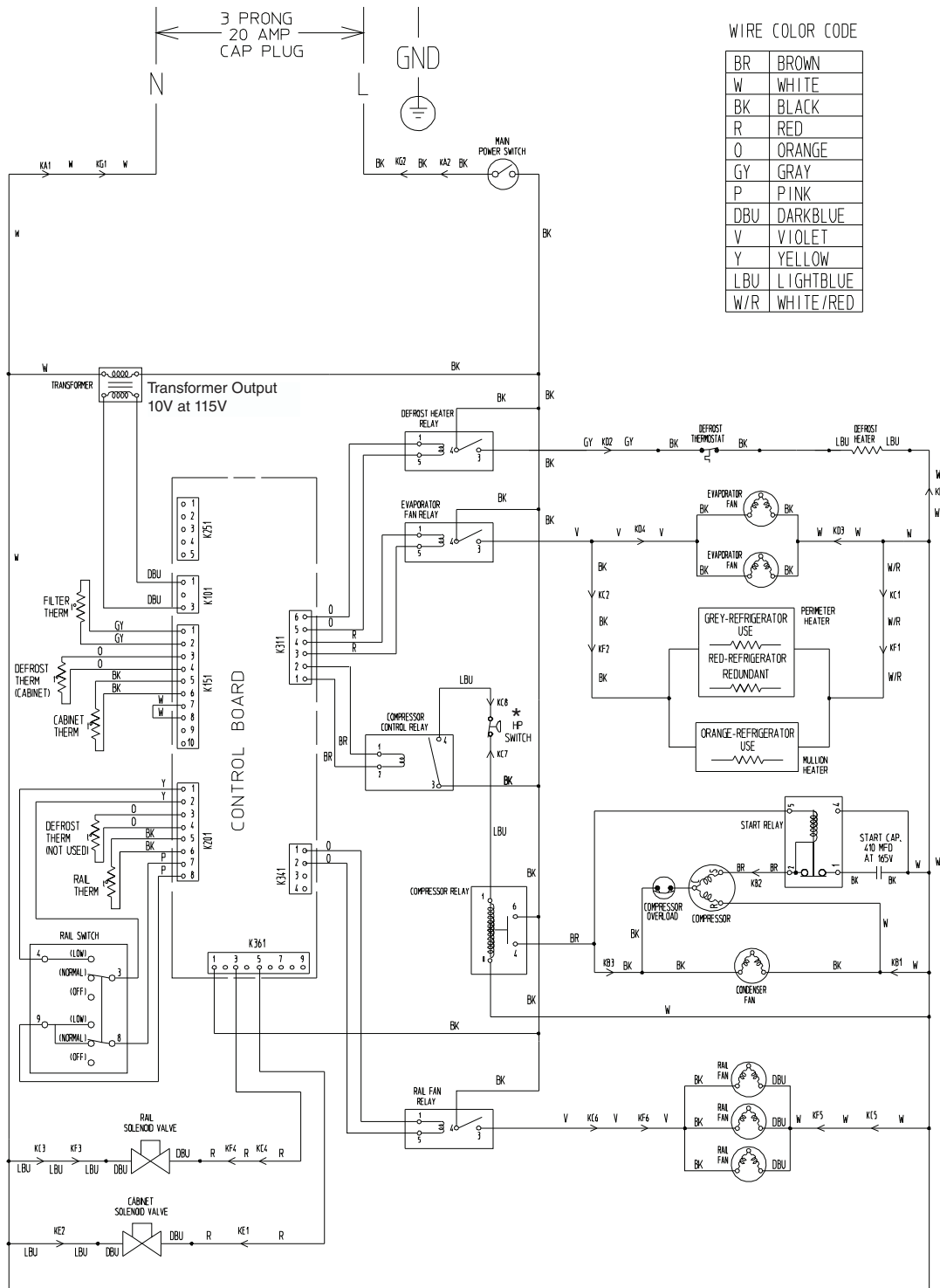

### \*High Pressure Switch

Cut-out	490±10 PSIG
Cut-in	370±20 PSIG

### 3. HPR100A(-D)

**AWAITING DATA**