

# Hoshizaki America, Inc.

## Professional and TempGuard Series Refrigerated Kitchen Equipment

Models  
SSB



“A Superior Degree  
of Reliability”

[www.hoshizaki.com](http://www.hoshizaki.com)

## SERVICE MANUAL



Number: 73077  
Issued: 3-8-1999  
Revised: 5-22-2012

**⚠ WARNING**

Only qualified service technicians should install and service the appliance. To obtain the name and phone number of your local Hoshizaki Certified Service Representative, visit [www.hoshizaki.com](http://www.hoshizaki.com). No service should be undertaken until the technician has thoroughly read this Service Manual. Failure to service and maintain the appliance in accordance with this manual will adversely affect safety, performance, component life, and warranty coverage. Proper installation is the responsibility of the installer. Product failure or property damage due to improper installation is not covered under warranty.

Hoshizaki provides this manual primarily to assist qualified service technicians in the service and maintenance of the appliance.

Should the reader have any questions or concerns which have not been satisfactorily addressed, please call, send an e-mail message, or write to the Hoshizaki Technical Support Department for assistance.

Phone: 1-800-233-1940; (770) 487-2331

Fax: 1-800-843-1056; (770) 487-3360

E-mail: [techsupport@hoshizaki.com](mailto:techsupport@hoshizaki.com)

HOSHIZAKI AMERICA, INC.

618 Highway 74 South

Peachtree City, GA 30269

Attn: Hoshizaki Technical Support Department

Web Site: [www.hoshizaki.com](http://www.hoshizaki.com)

**NOTE:** To expedite assistance, all correspondence/communication **MUST** include the following information:

- Model Number \_\_\_\_\_
- Serial Number \_\_\_\_\_
- Complete and detailed explanation of the problem.

## **IMPORTANT**

This manual should be read carefully before the appliance is serviced. Read the warnings and guidelines contained in this booklet carefully as they provide essential information for the continued safe use, service, and maintenance of the appliance. Retain this booklet for any further reference that may be necessary.

## **CONTENTS**

Important Safety Information .....	6
I. Specifications.....	9
A. Electrical and Refrigerant Data .....	9
II. General Information .....	10
A. Construction .....	10
1. One Section .....	10
2. Two Section .....	11
3. Three Section .....	12
4. Pass Thru .....	13
5. Roll-In .....	14
6. Roll Thru .....	15
B. Sequence of Operation .....	16
1. Sequence Cycles and Shutdown .....	16
a) Refrigerator and RFH1-SSB(-HD)(-HS)(-HSE) Refrigerator .....	16
b) Freezer and RFH1-SSB(-HD)(-HS)(-HSE) Freezer .....	18
2. Sequence Flow Chart.....	23
a) Refrigerator .....	23
b) Freezer.....	24
C. Display Board.....	25
1. Location .....	25
2. Display Board Layout.....	25
D. Control Board .....	26
1. Location .....	26
2. Control Board Layout.....	27
E. Controls and Adjustments .....	28
1. Guarded Access Menu .....	28
a) Temperature Setpoint.....	28
b) Defrost Frequency.....	28
c) Temperature Display Scale (°F or °C) .....	29
2. Service Menu .....	30
3. LED Lights and Alarm Safeties Chart.....	31
4. Default Dip Switch Settings.....	33
a) Appliance Operation (Freezer/Refrigerator) (S3 dip switch 1).....	34
b) Cabinet Light/Heated Glass Door (S3 dip switch 2).....	34
c) Door Switch Type (S3 dip switch 3).....	34
d) Refrigerator Defrost Initiation Temperature (S3 dip switch 4).....	34
e) Display Board Operation (S3 dip switch 5) .....	35
f) Dual Temp Models (S3 dip switch 6).....	35
g) Freezer Evaporator Fan Operation (except RFH1) (S3 dip switch 7) .....	35
h) Dual Temp Freezer Component Control (S3 dip switch 8) .....	36

F. Compressor Protector, Short Cycle Protection, and High-Pressure Switch.....	37
G. Perimeter Frame Heater .....	37
H. Thermistors .....	37
I. Glass Door Heater.....	37
III. Service Diagnosis.....	38
A. Diagnostic Procedure .....	38
1. Refrigerator and RFH1-SSB(-HD)(-HS)(-HSE) Refrigerator.....	39
2a. Freezer (auxiliary code P-5 and earlier) and RFH1-SSB(-HS)(-HSE) Freezer ...	43
2b. Freezer (auxiliary code P-6 and later) and RFH1-SSB-HD Freezer.....	47
B. Control Board Check.....	52
C. Thermistor Check.....	53
D. Clogged Filter Thermostat and High-Pressure Switch.....	54
E. Diagnostic Chart .....	55
IV. Replacement of Components .....	57
A. Service for Refrigerant Lines.....	57
1. Refrigerant Recovery .....	57
2. Brazing .....	58
3. Evacuation and Recharge (R-404A).....	58
B. Important Notes for Component Replacement.....	59
C. Removal and Replacement of Evaporator Fan Shroud Assembly.....	60
D. Removal and Replacement of Heat Shield on FH2-SSB(-HD) .....	61
E. Removal and Replacement of Door Closure Spring .....	62
F. Door Re-Hinging (except glass doors) .....	63
V. Maintenance .....	64
A. Cleaning Instructions .....	64
1. Exterior.....	64
2. Cabinet Interior.....	64
3. Door Gaskets.....	64
4. Shelves.....	64
5. Glass Door.....	64
B. Maintenance.....	65
1. Condenser.....	65
2. Power Supply Connection.....	65
C. Preparing the Appliance for Periods of Non-Use.....	65
VI. Disposal.....	66

VII. Wiring Diagrams .....	67
A1. RH1-SSB(-HD) (auxiliary code L-5 and earlier) .....	67
A2. RH1-SSB(-HD)(-CF) (auxiliary code M-5 and later) .....	68
B1. RH2-SSB(-HD) (auxiliary code L-5 and earlier) .....	69
B2. RH2-SSB(-HD) (auxiliary code M-5 and later) .....	70
C1. RH3-SSB(-HD) (auxiliary code L-5 and earlier) .....	71
C2. RH3-SSB(-HD) (auxiliary code M-5 and later) .....	72
D1. RH1-SSB-GD (auxiliary code N-6 and earlier) .....	73
D2. RH1-SSB-GD (auxiliary code P-5 and later) .....	74
E1. RH2-SSB-GD (auxiliary code N-6 and earlier) .....	75
E2. RH2-SSB-GD (auxiliary code P-5 and later) .....	76
F1. RH3-SSB-GD (auxiliary code S-5 and earlier) .....	77
F2. RH3-SSB-FG(-HG) (auxiliary code T-5 to V-5) .....	78
F3. RH3-SSB-FG(-HG) (auxiliary code A-5 and later) .....	79
G1. FH1-SSB(-HD) (auxiliary code P-5 and earlier) .....	80
G2. FH1-SSB(-HD) (auxiliary code P-6 to S-5) .....	81
G3. FH1-SSB(-HD) (auxiliary code S-6 and later) .....	82
H1. FH2-SSB(-HD) (auxiliary code P-5 and earlier) .....	83
H2. FH2-SSB(-HD)(-HDCU) (auxiliary code P-6 and later) .....	84
I. RFH1-SSB-HD .....	85
1. Refrigerator .....	85
2a. Freezer (auxiliary code P-5 and earlier) .....	86
2b. Freezer (auxiliary code Q-5 and later) .....	87
J. RFH1-SSB(-HS)(-HSE) .....	88
1. Refrigerator .....	88
2. Freezer .....	89
K. RFH2-SSB(-HD) .....	90
L. RFH3-SSB(-HD) .....	90
M. PTR1SSB01-10 .....	91
N. PTR1SSB(-FSFS)(-HSHS) .....	92
O. PTR1SSB(-FGFG)(HGHS)(-HG HG) (Auxiliary Code T-5 and Earlier) .....	93
P. PTR1SSB(-FGFG)(-HGHS)(-HG HG) (Auxiliary Code T-6 and Later) .....	94
Q. PTR2SSB(-FSFS)(-HSHS) .....	95
R. PTR2SSB(-FGFG)(-HG HG) .....	96
S. RIR1-SSB .....	97
T. RIR2-SSB .....	98
U. RIR2-SSB51-02 .....	99
V. RTR1-SSB .....	100

---

## Important Safety Information

Throughout this manual, notices appear to bring your attention to situations which could result in death, serious injury, or damage to the appliance or damage to property.

**⚠ WARNING** Indicates a hazardous situation which could result in death or serious injury.

**NOTICE** Indicates a situation which could result in damage to the appliance or property.

**IMPORTANT** Indicates important information about the use and care of the appliance.

### **⚠ WARNING**

This appliance should be destined only to the use for which it has been expressly conceived. Any other use should be considered improper and therefore dangerous. The manufacturer cannot be held responsible for injury or damage resulting from improper, incorrect, and unreasonable use. Failure to service and maintain the appliance in accordance with this manual will adversely affect safety, performance, component life, and warranty coverage.

**To reduce the risk of death, electric shock, serious injury, or fire, follow basic precautions including the following:**

- Only qualified service technicians should install and service this appliance.
- This appliance must be installed in accordance with applicable national, state, and local codes and regulations.

#### **For Power Cord Models**

- This appliance requires an independent power supply of proper capacity. See the nameplate for electrical specifications. Failure to use an independent power supply of proper capacity can result in a tripped breaker, blown fuse, or damage to existing wiring. This could lead to heat generation or fire.
- To reduce the risk of electric shock, do not touch the plug or power switch with damp hands.
- Make sure the power switch is in the "OFF" position before plugging in or unplugging the appliance to reduce the risk of electric shock.
- Before servicing, move the power switch to the "OFF" position. Unplug the appliance from the electrical outlet.
- Do not use an extension cord.
- Do not use an appliance with a damaged power cord. The power cord should not be altered, jerked, bundled, weighed down, pinched, or tangled. Such actions could result in electric shock or fire. To unplug the appliance, be sure to pull the plug, not the cord, and do not jerk the cord.

## **⚠ WARNING, continued**

- **THIS APPLIANCE MUST BE GROUNDED.** This appliance is equipped with a NEMA 5-15 three-prong grounding plug  to reduce the risk of potential shock hazards. It must be plugged into a properly grounded, independent 3-prong wall outlet. If the outlet is a 2-prong outlet, it is your personal responsibility to have a qualified electrician replace it with a properly grounded, independent 3-prong wall outlet. Do not remove the ground prong from the plug and do not use an adapter plug. Failure to follow these instructions could result in death, serious injury, fire, or damage to the appliance.
- The GREEN ground wire in the factory-installed power cord is connected to the appliance. If it becomes necessary to remove or replace the power cord, be sure to connect the power cord's ground wire.

### **For Hard-Wired Models**

- Electrical connection must be hard-wired and must meet national, state, and local electrical code requirements. Failure to meet these code requirements could result in death, electric shock, serious injury, fire, or severe damage to equipment.
- This appliance requires an independent power supply of proper capacity. See the nameplate for electrical specifications. Failure to use an independent power supply of proper capacity can result in a tripped breaker, blown fuse, or damage to existing wiring. This could lead to heat generation or fire.
- To reduce the risk of electric shock, do not touch the power switch with damp hands.
- Before servicing, move the power switch to the "OFF" position and turn off the power supply. Lockout/Tagout to prevent the power supply from being turned back on inadvertently.
- **THIS APPLIANCE MUST BE GROUNDED.** Failure to properly ground this appliance could result in death, serious injury, fire, or damage to the appliance.

### **For All Models:**

- Do not splash, pour, or spray water directly onto or into the appliance. This might cause short circuit, electric shock, corrosion, or failure.
- Do not make any alterations to the appliance. Alterations could result in electric shock, injury, fire, or damage to the appliance.
- This appliance is not intended for use by persons (including children) with reduced physical, sensory, or mental capabilities, or lack of experience and knowledge, unless they have been given supervision or instruction concerning use of the appliance by a person responsible for their safety.
- Children should be properly supervised around this appliance.
- Do not climb, stand, or hang on the appliance or doors or allow children or animals to do so. Do not climb into the appliance or allow children or animals to do so. Death or serious injury could occur or the appliance could be damaged.
- Be careful not to pinch fingers when opening and closing the doors. Be careful when opening and closing the doors when children are in the area.

### **⚠ WARNING, continued**

- Open and close the doors with care. Doors opened too quickly or forcefully may cause injury or damage to the appliance or surrounding equipment.
- Do not use combustible spray or place volatile or flammable substances near the appliance. They might catch fire.
- Keep the area around the appliance clean. Dirt, dust, or insects in the appliance could cause harm to individuals or damage to the appliance.
- Do not tightly pack the cabinet. Allow some space between items to ensure good air flow. Also allow space between items and interior surfaces.
- Do not throw anything onto the shelves or load any single shelf with more than 120 lb. (54.5 kg) of product. They might fall off and cause injury.
- This appliance is designed only for temporary storage of food. Employ sanitary methods. Use for any other purposes (for example, storage of chemicals or medical supplies such as vaccine and serum) could cause deterioration of stored items.
- Do not block air inlets or outlets, otherwise cooling performance may be reduced.
- Do not put warm or hot foods in the cabinet. Let them cool first, or they will raise the cabinet temperature and could deteriorate other foods in the cabinet or overload the appliance.
- All foods should be wrapped in plastic film or stored in sealed containers. Otherwise foods may dry up, pass their smells onto other foods, cause frost to develop, result in poor appliance performance, or increase the likelihood of cross-contamination. Certain dressings and food ingredients, if not stored in sealed containers, may accelerate corrosion of the evaporator, resulting in failure.
- Do not store items near air outlets. Otherwise, items may freeze up and crack or break causing a risk of injury or contamination of other food.

### ***NOTICE***

- Protect the floor when moving the appliance to prevent damage to the floor.
- Keep ventilation openings, in the appliance enclosure or in the built-in structure, clear of obstruction. Do not place anything on top of the appliance. Blockage of airflow could negatively affect performance and damage the appliance.
- To prevent deformation or cracks, do not spray insecticide onto the plastic parts or let them come into contact with oil.
- To avoid damage to the gasket, use only the door handle when opening and closing.

# I. Specifications

## A. Electrical and Refrigerant Data

Model	AC Supply Voltage	Amperes	Design Pressure (PSIG)		Refrigerant
			HI	LO	R-404A
RH1-SSB(-HD)(-CF)	115/60/1	7.0	450	200	12.2 oz.
RH2-SSB(-HD)	115/60/1	10.0	450	200	18.2 oz.
RH3-SSB(-HD)(-FG)(-HG)	115/60/1	13.0	450	200	23.2 oz.
RH1-SSB-GD	115/60/1	10.7	450	200	16.1 oz.
RH2-SSB-GD	115/60/1	11.8	400	200	21.5 oz.
RH3-SSB-GD	115/60/1	15.5	450	250	31.4 oz.
FH1-SSB(-HD)	115/60/1	11.0	450	250	15.2 oz.
FH2-SSB(-HD)	115/60/1	15.5	450	250	20.1 oz.
FH2-SSB-HDCU	115/60/1	15.5	450	250	20.1 oz.
PTR1SSB-xxxx / PTR1SSB01-10	115/60/1	12.0	450	250	15.5 oz.
PTR2SSB-FSFS(-HSHS)	115/60/1	12.0	450	250	21.5 oz.
PTR2SSB-FGFG(-HGHG)	115/60/1	12.8	450	250	17.3 oz.
RIR1-SSB	115/60/1	7.0	450	200	12.2 oz.
RIR2-SSB	115/60/1	11.0	450	200	18.2 oz.
RIR2-SSB51-02	115/60/1	11.0	450	200	18.2 oz.
RTR1-SSB	115/60/1	7.0	450	200	12.2 oz.

Model	AC Supply Voltage	Amperes	Design Pressure (PSIG)				Refrigerant		
			Refrigerator		Freezer		R-404A		R-134a
			HI	LO	HI	LO	Ref.	Freezer	Ref.
RFH1-SSB-HD	115/60/1	16.0	450	250	450	250	9.5 oz.	12.0 oz.	-
RFH1-SSB(-HS)(-HSE)	115/60/1	9.5	240	120	450	250	-	12.1 oz.	9.1 oz.
RFH2-SSB(-HD)	115/60/1	16.6	450	200	450	250	12.2 oz.	15.2 oz.	-
RFH3-SSB(-HD)	115/60/1	20	450	200	450	250	18.2 oz.	15.2 oz.	-

See the nameplate for electrical and refrigeration specifications. The nameplate is located on the right side wall of the cabinet interior.

Note: We reserve the right to make changes in specifications and design without prior notice.

## II. General Information

### A. Construction

#### 1. One Section

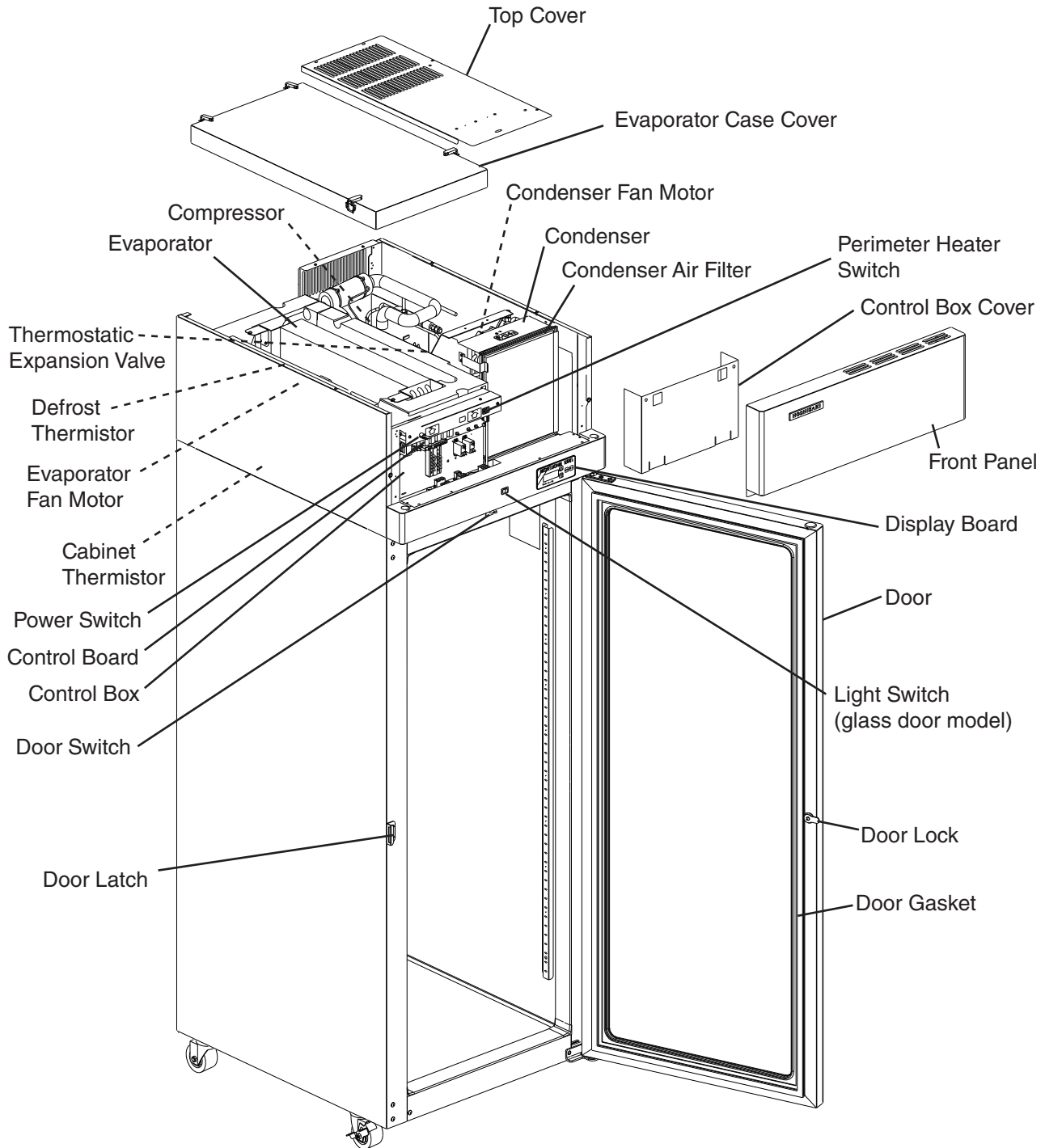

Model Shown: RH1-SSB-FG

## 2. Two Section

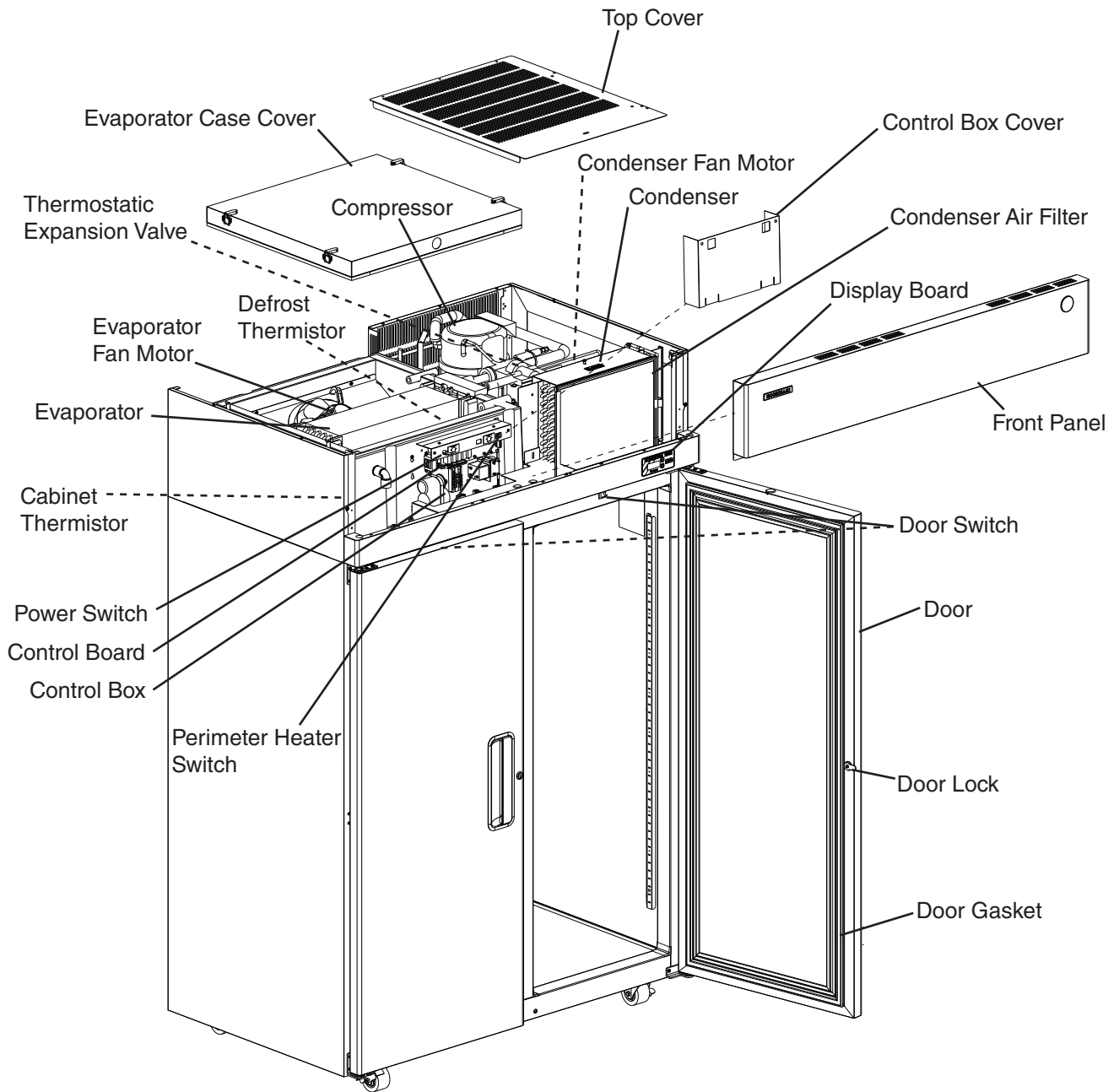

Model Shown: RH2-SSB

### 3. Three Section

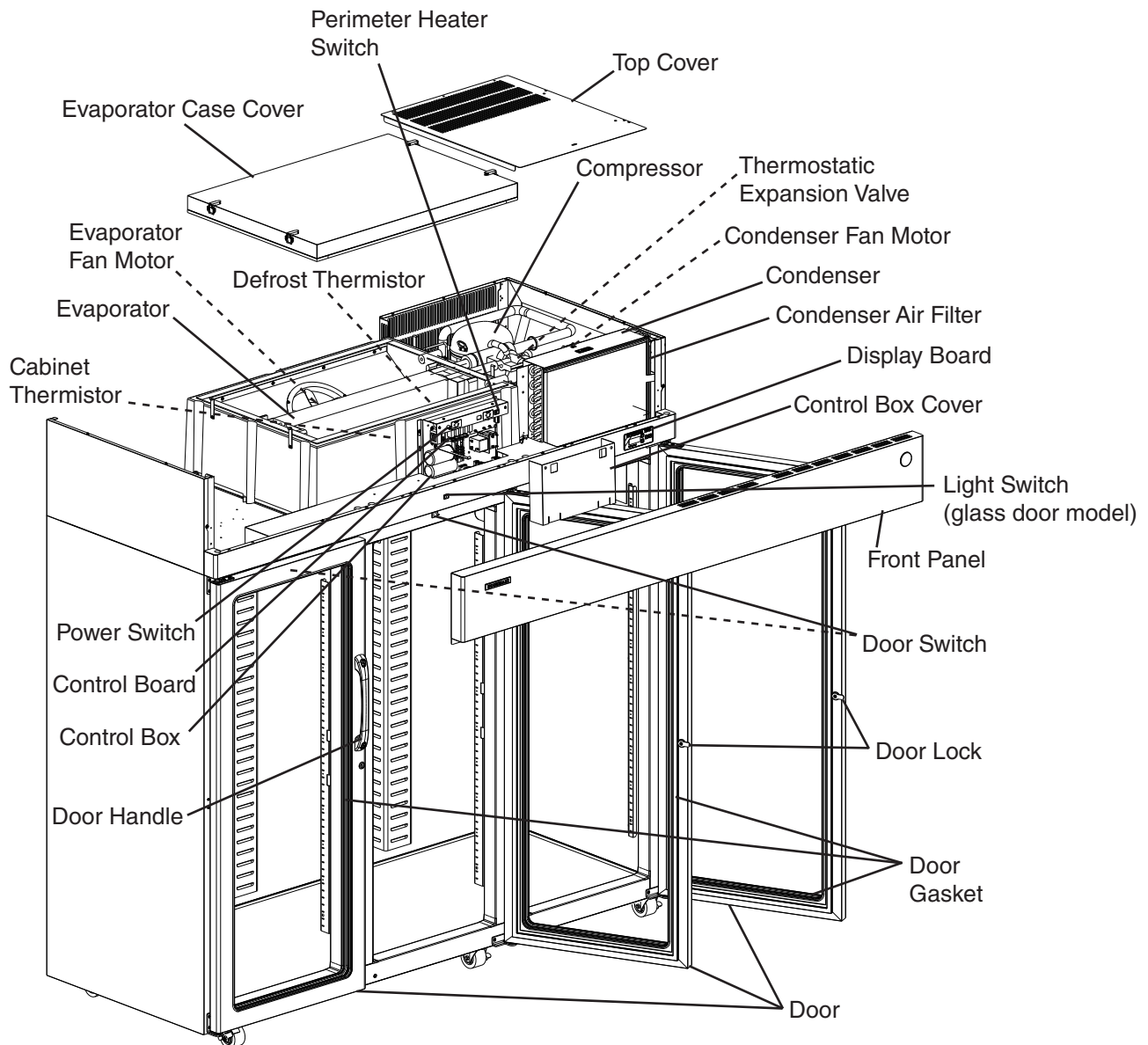

Model Shown: RH3-SSB-FG

## 4. Pass Thru

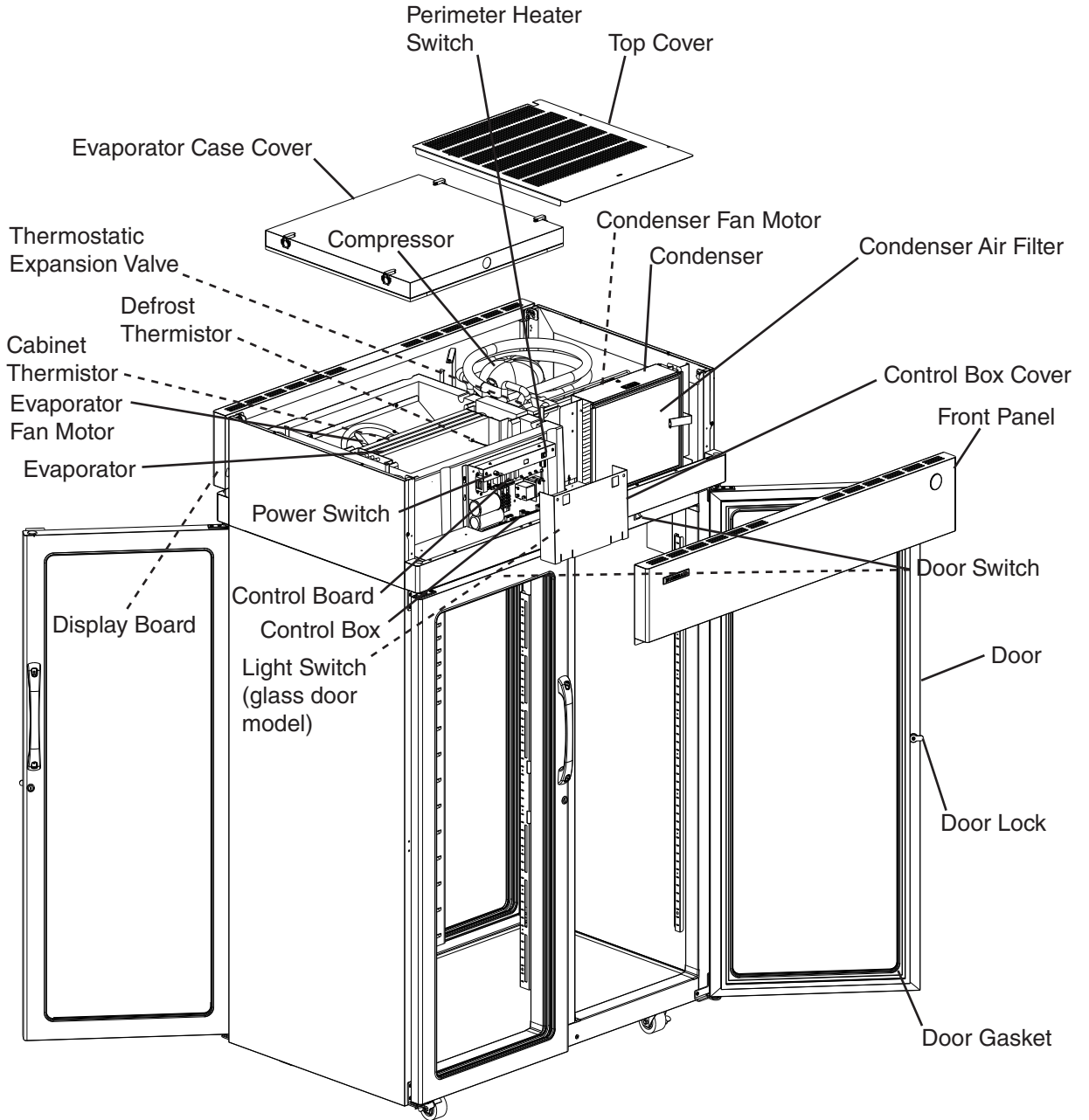

Model Shown: PTR2SSB-FGFG

## 5. Roll-In

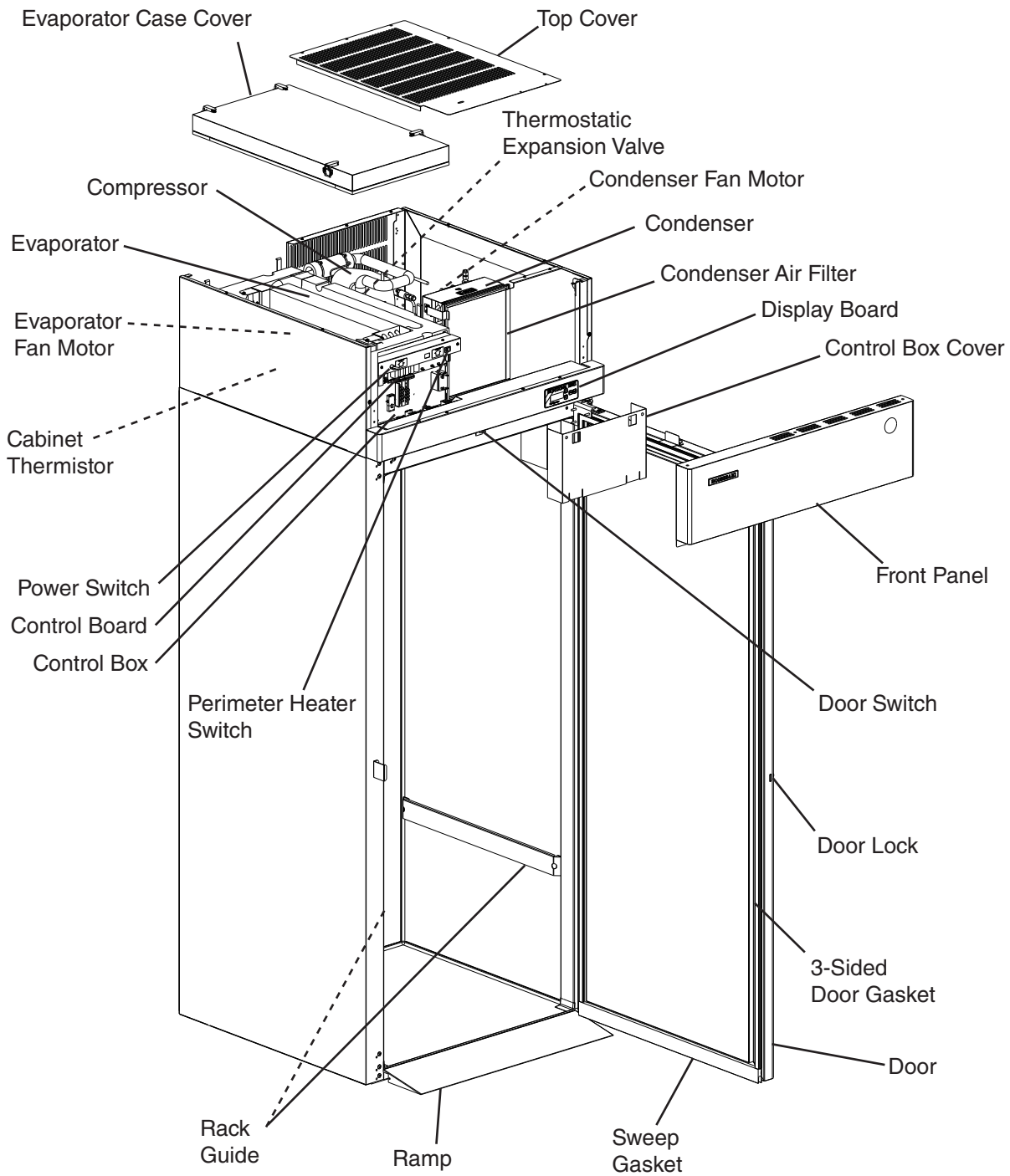

**Model Shown: RIR1-SSB**

## 6. Roll Thru

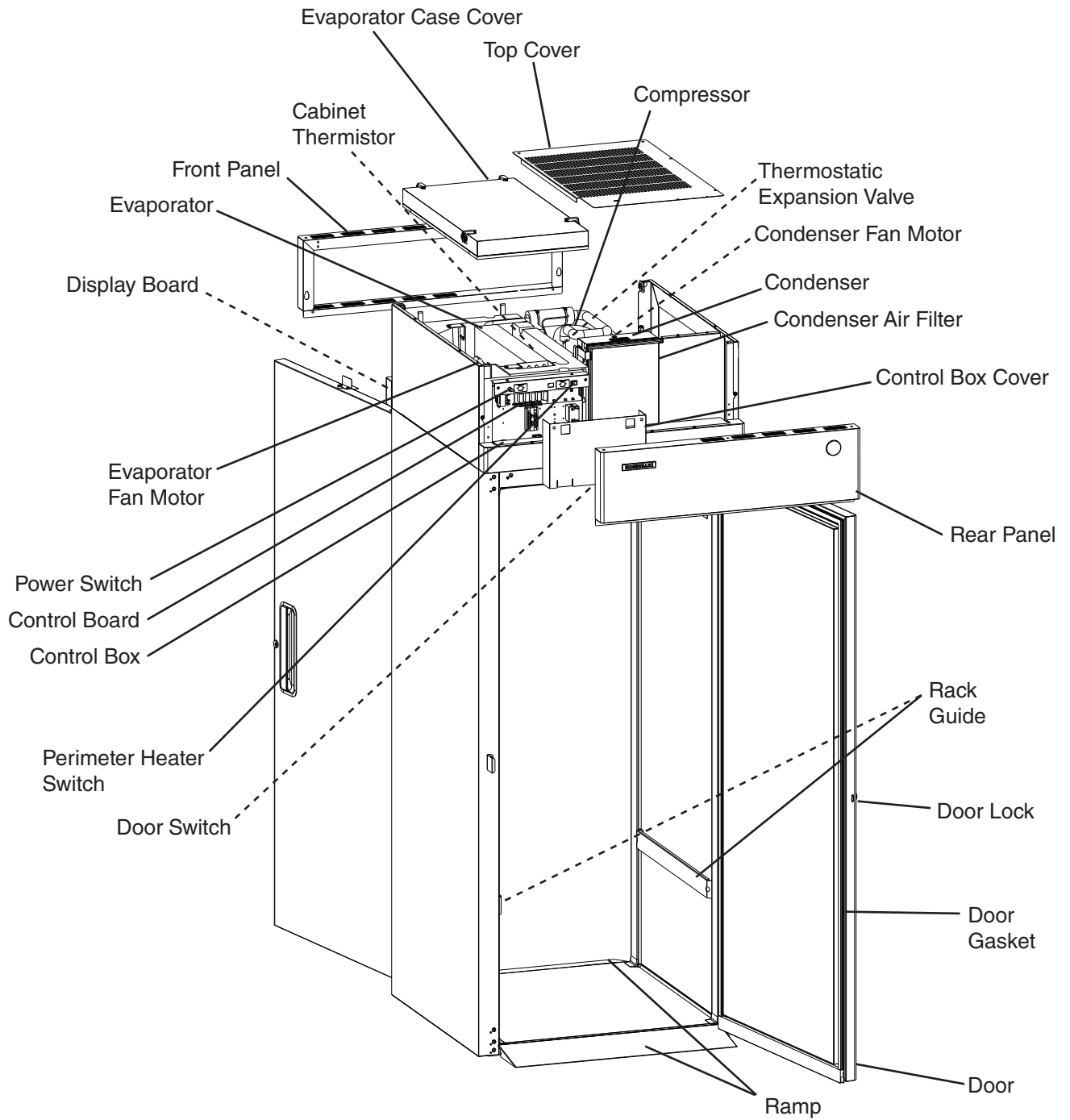

Model Shown: RTR1-SSB

## B. Sequence of Operation

### 1. Sequence Cycles and Shutdown

The steps in the sequence are as outlined below. When power is supplied and the power switch is in the "ON" position, CB red "POWER OK" LED comes on and CB revision (r ##) appears on DB.

Note: There is a minimum 2.5-minute Comp on time and 2.5-minute Comp off time.

RFH1-SSB(-HS)(-HSE): Power is supplied to CPM as soon as the power switch is placed in the "ON" position. F/S controls CPM operation.

#### a) Refrigerator and RFH1-SSB(-HD)(-HS)(-HSE) Refrigerator

##### 1) Startup

**No Component LEDs are on. LED 3 (EvapFM on) is off:** EvapFM energizes.

2.5-minute Comp delay timer starts. Cabinet temperature appears on DB.

Note: EvapFM energizes at startup and runs continuously, de-energizing for open doors only.

##### 2a) Cool Down–Refrigerator

**LEDs 4 (Comp) and 5 (ConFM) are on:** EvapFM continues. 2.5-minute Comp delay timer terminates. Comp and ConFM energize. 2.5 min. Comp minimum run timer starts.

##### 2b) Cool Down–RFH1-SSB(-HD)(-HS)(-HSE) Refrigerator

**LEDs 4 (Comp and ConFM) and 5 (unused) are on:** EvapFM continues. 2.5 minute Comp delay timer terminates. Comp and ConFM energize. 2.5 min. Comp minimum run timer starts.

##### 3) Cool Down Achieved

**No Component LEDs are on. LED 3 (EvapFM on) is off:** CB monitors cooling of the cabinet via CTh. CTh cools to 3°F (1.7°C) below setpoint. EvapFM continues, Comp and ConFM de-energize. 2.5 min. Comp minimum off timer starts.

##### 4a) Cool Down Restart–Refrigerator

**LEDs 4 (Comp) and 5 (ConFM) are on:** CTh warms to 3°F (1.7°C) above setpoint. EvapFM continues, Comp and ConFM energize. 2.5 min. Comp minimum run timer starts.

##### 4b) Cool Down Restart–RFH1-SSB(-HD)(-HS)(-HSE) Refrigerator

**LEDs 4 (Comp and ConFM) and 5 (unused) are on:** CTh warms to 3°F (1.7°C) above setpoint. EvapFM continues, Comp and ConFM energize. 2.5 min. Comp minimum run timer starts.

## 5) Defrost

### A1. Temperature-Initiation

- 1) **Refrigerator–LED 5 (ConFM) is on. LED 3 (EvapFM on) is off:** DTh cools to 13°F (-10°C) (8°F (-13°C) for Pass-Thrus). 20 min. minimum off cycle defrost starts. Cabinet temperature displayed on DB. EvapFM continues. ConFM continues or energizes.
- 2) **RFH1-SSB(-HD)(-HS)(-HSE) Refrigerator–LED 5 (unused) is on. LED 3 (EvapFM on) is off:** DTh cools to 13°F (-10°C). 20 min. minimum off cycle defrost starts. Cabinet temperature displayed on DB. EvapFM continues. Comp and ConFM de-energize.

### A2. Time-Initiation

If the factory time-initiated setting is moved from 0 defrosts per 24 hours, the appliance enters the defrost cycle when the time of the new setting terminates. Defrost timer terminates, CB initiates defrost. Defrost sequence same as "5)A1. Temperature-Initiation" above.

### B. Defrost Termination

- 1) **Refrigerator–LEDs 4 (Comp) and 5 (ConFM) are on. LED 3 (EvapFM on) is off:** DTh warms to 40°F (4°C). EvapFM and ConFM continue. 2.5 minute Comp delay timer terminates. Comp energizes.
- 2) **RFH1-SSB(-HD)(-HS)(-HSE) Refrigerator–LEDs 4 (Comp and ConFM) and 5 (unused) are on. LED 3 (EvapFM on) is off:** DTh warms to 40°F (4°C). EvapFM continues. 2.5 minute Comp delay timer terminates. Comp and ConFM energize.

### Note:

- Perimeter heater controlled by perimeter heater switch.
- Glass door (-GD models) heater controlled by glass door heater switch.
- CPM RFH1-SSB(-HS)(-HSE) Refrigerator: CPM has power supply as soon as the power switch is placed in the "ON" position. CPM operates as needed via the float switch.

Legend: **CB**–control board; **Comp**–compressor; **ConFM**–condenser fan motor; **CPM**–condensate pump motor (RFH1-SSB(-HS)(-HSE) Refrigerator); **CTh**–cabinet thermistor; **DB**–display board; **DTh**–defrost thermistor; **EvapFM**–evaporator fan motor; **F/S**–float switch

## **b) Freezer and RFH1-SSB(-HD)(-HS)(-HSE) Freezer**

1a) *Startup: Freezer (auxiliary code P-5 and earlier) and RFH1-SSB(-HS)(-HSE) Freezer*  
**LED 3 (EvapFM off) is on:** 2.5-minute Comp delay timer starts. Cabinet temperature appears on DB.

1b) *Startup: Freezer (auxiliary code P-6 and later) and RFH1-SSB-HD Freezer*  
**No Component LEDs are on. LED 3 (EvapFM on) is off:** EvapFM energizes. 2.5-minute Comp delay timer starts. Cabinet temperature appears on DB.

Note: Evaporator Fan Motor Operation (LED 3 EvapFM): LED 3 is off when EvapFM is on and LED 3 is on when EvapFM is off.

**S3 dip switch 7 or 8 in the "OFF" position:** All freezers (auxiliary code P-5 and earlier) and RFH1-SSB(-HS)(-HSE) freezer, EvapFM energizes with Comp and cycles on and off with Comp. EvapFM de-energizes when door is open.

**S3 dip switch 7 or 8 in the "ON" position:** All freezers (auxiliary code P-6 and later) and RFH1-SSB-HD freezer, EvapFM energizes at startup and runs continuously, de-energizing for defrost and open doors only. See "II.E.4.g) Freezer Evaporator Fan Operation (except RFH1) (S3 dip switch 7)" and "II.E.4.h) RFH1 Freezer Evaporator Fan Motor and Heaters (S3 dip switch 8)." Dip switch 8 is only used on RFH1-SSB-HD model.

2a) *Cool Down: Freezer (auxiliary code P-5 and earlier)*

**LEDs 4 (Comp) and 5 (ConFM) are on. LED 3 (EvapFM on) is off:** 2.5-minute Comp delay timer terminates. Comp, ConFM, and EvapFM energize.

2b) *Cool Down: Freezer (auxiliary code P-6 and later)*

**LEDs 4 (Comp) and 5 (ConFM) are on. LED 3 (EvapFM on) is off:** 2.5-minute Comp delay timer terminates. EvapFM continues. Comp and ConFM energize.

2c) *Cool Down: RFH1-SSB-HD Freezer*

**LED 4 (Comp and ConFM) is on. LED 3 (EvapFM on) is off:** 2.5-minute Comp delay timer terminates. EvapFM continues. Comp and ConFM energize.

2d) *Cool Down: RFH1-SSB(-HS)(-HSE) Freezer*

**LEDs 4 (Comp and ConFM) and 5 (DrH, PH, and MH) are on. LED 3 (EvapFM on) is off:** 2.5-minute Comp delay timer terminates. Comp, ConFM, EvapFM, DrH, PH, and MH energize. 2.5 min. Comp minimum run timer starts.

3a) *Cool Down Achieved: Freezer (auxiliary code P-5 and earlier) and RFH1-SSB(-HS)(-HSE) Freezer*

**LED 3 (EvapFM off) is on:** CB monitors cooling of the cabinet via CTh. CTh cools to 3°F (1.7°C) below setpoint. Comp, ConFM, and EvapFM de-energize. DrH, PH, and MH de-energize (RFH1-SSB(-HS)(-HSE)).

3b) *Cool Down Achieved: Freezer (auxiliary code P-6 and later)*

**No Component LEDs are on. LED 3 (EvapFM on) is off:** CB monitors cooling of the cabinet via CTh. CTh cools to 3°F (1.7°C) below setpoint. EvapFM continues. Comp and ConFM de-energize.

3c) *Cool Down Achieved: RFH1-SSB-HD Freezer*

**LED 5 (CPH and DrH (auxiliary code Q-5 and later)) is on. LED 3 (EvapFM on) is off:** CB monitors cooling of the cabinet via CTh. CTh cools to 3°F (1.7°C) below setpoint. EvapFM continues. Comp and ConFM de-energize. CPH and DrH (auxiliary code Q-5 and later) energize.

4a) *Cool Down Restart: Freezer (auxiliary code P-5 and earlier)*

**LEDs 4 (Comp) and 5 (ConFM) are on. LED 3 (EvapFM on) is off:** CTh warms to 3°F (1.7°C) above setpoint. 2.5-minute Comp off delay timer terminates. Comp, ConFM, and EvapFM energize.

4b) *Cool Down Restart: Freezer (auxiliary code P-6 and later)*

**LEDs 4 (Comp) and 5 (ConFM) are on. LED 3 (EvapFM on) is off:** CTh warms to 3°F (1.7°C) above setpoint. 2.5-minute Comp off delay timer terminates. EvapFM continues. Comp and ConFM energize.

4c) *Cool Down Restart: RFH1-SSB-HD Freezer*

**LEDs 4 (Comp and ConFM) and 5 (CPH and DrH (auxiliary code Q-5 and later)) are on. LED 3 (EvapFM on) is off:** CTh warms to 3°F (1.7°C) above setpoint. 2.5-minute Comp off delay timer terminates. EvapFM, CPH, and DrH (auxiliary code Q-5 and later) continue. Comp and ConFM energize.

4d) *Cool Down Restart: RFH1-SSB(-HS)(-HSE) Freezer*

**LEDs 4 (Comp and ConFM) and 5 (DrH, PH, and MH) are on. LED 3 (EvapFM on) is off:** CTh warms to 3°F (1.7°C) above setpoint. 2.5-minute Comp delay timer terminates. Comp, ConFM, EvapFM, DrH, PH and MH energize.

5a) *Defrost: Freezer (auxiliary code P-5 and earlier) and RFH1-SSB(-HS)(-HSE) Freezer*

(1) Time-Initiated Defrost or Manual-Initiated Defrost

a1) **Freezer (auxiliary code P-5 and earlier)–LEDs 1 (DH) and 3 (EvapFM off) are on:** DT terminates or manual defrost initiated. 20-minute minimum defrost timer starts. 1-hour maximum defrost timer starts. DH energizes. "dEF" displayed on DB. If energized, Comp, ConFM, and EvapFM de-energize.

a2) **RFH1-SSB(-HS)(-HSE) Freezer–LEDs 1 (DH) and 3 (EvapFM off) are on:** DT terminates or manual defrost initiated. 20-minute minimum defrost timer starts. 1-hour maximum defrost timer starts. DH energizes. "dEF" displayed on DB. If energized, Comp, ConFM, and EvapFM de-energize. DrH, PH, and MH de-energize.

The time-initiated defrost is factory set to 6 times per day (every 4 hours. For further details, see "II.E.1.b) Defrost Frequency." Before changing this setting, contact Hoshizaki Technical Support at 1-800-233-1940 for recommendations.

(2) Defrost Termination: Defrost Recovery Step 1

- a1) **Freezer (auxiliary code P-5 and earlier)–LEDs 4 (Comp) and 5 (ConFM) are on. LED 3 (EvapFM on) is off:** DTh warms to 100°F (38°C) or 1-hour defrost timer terminates. DH de-energizes. 5-minutes later, Comp and ConFM energize.
- a2) **RFH1-SSB(-HS)(-HSE) Freezer–LEDs 4 (Comp and ConFM) and 5 (DrH, PH, and MH) are on:** DTh warms to 100°F (38°C) or 1-hour defrost timer terminates. DH de-energizes. 5-minutes later, Comp, ConFM, DrH, PH, and MH energize.

(3) Defrost Termination: Defrost Recovery Step 2

- a1) **Freezer (auxiliary code P-5 and earlier)– LEDs 4 (Comp) and 5 (ConFM) are on. LED 3 (EvapFM on) is off:** DTh cools to 70°F (21°C) or lower, EvapFM energizes.
- a2) **RFH1-SSB(-HS)(-HSE) Freezer–LEDs 4 (Comp and ConFM) and 5 (DrH, PH, and MH) are on. LED 3 (EvapFM) is off:** DTh cools to 70°F (21°C) or lower, EvapFM energizes.

(4) Defrost Completiton

- a1) **Freezer (auxiliary code P-5 and earlier)–LEDs 4 (Comp), and 5 (ConFM) are on. LED 3 (EvapFM on) off:** When CTh reads 15°F (8.3°C) above setpoint or less, cabinet temperature is displayed on DB. Defrost is complete.
- a2) **RFH1-SSB(-HS)(-HSE) Freezer–LEDs 4 (Comp and ConFM), and 5 (DrH, PH, and MH) are on. LED 3 (EvapFM on) off:** When CTh reads 15°F (8.3°C) above setpoint or less, cabinet temperature is displayed on DB. Defrost is complete.

5b) Defrost: Freezer (auxiliary code P-6 and later) and RFH1-SSB-HD Freezer

(1) Time-Initiated Defrost or Manual-Initiated Defrost

- a1) **Freezer (auxiliary code P-6 and later)–LEDs 1 (DH, DrH, DctH, and CordH) and 3 (EvapFM off) are on:** DT terminates or manual defrost initiated. 20-minute minimum defrost timer starts. 1-hour maximum defrost timer starts. DH, DrH, DcTH, and CordH energize. "dEF" displayed on DB. If energized, Comp, ConFM, and EvapFM de-energize.
- a2) **RFH1-SSB-HD Freezer–LEDs 1 (DH), 3 (EvapFM off), and 5 (CPH and DrH (auxiliary code Q-5 and later)) are on:** DT terminates or manual defrost initiated. 20-minute minimum defrost timer starts. 1-hour maximum defrost timer starts. CPH and DrH (auxiliary code Q-5 and later) continue. DH energizes. "dEF" displayed on DB. If energized, Comp, ConFM, and EvapFM de-energize.

The time-initiated defrost is factory set to 6 times per day (every 4 hours). For further details, see "II.E.1.b) Defrost Frequency."

Before changing this setting, contact Hoshizaki Technical Support at 1-800-233-1940 for recommendations.

Note: Some models may utilize any combination of the following heaters during defrost: Duct Heater, Cord Heater, or Drain Heater. See "VII.Wiring Diagrams" for specific model details.

(2) Defrost Termination: Defrost Recovery Step 1

- a1) **Freezer (auxiliary code P-6 and later)–LEDs 3 (EvapFM off), 4 (Comp), and 5 (ConFM) are on:** DTh warms to 100°F (38°C) or 1-hour defrost timer terminates. DH de-energizes. 5-minutes later, Comp and ConFM energize.
- a2) **RFH1-SSB-HD Freezer–LEDs 3 (EvapFM off), 4 (Comp and ConFM), and 5 (CPH and DrH (auxiliary code Q-5 and later)) are on:** DTh warms to 100°F (38°C) or 1-hour defrost timer terminates. DH de-energizes. 5-minutes later, Comp and ConFM energize. CPH and DrH (auxiliary code Q-5 and later) continue.

(3) Defrost Termination: Defrost Recovery Step 2

- a1) **Freezer (auxiliary code P-6 and later)–LEDs 4 (Comp) and 5 (ConFM) are on. LED 3 (EvapFM on) is off:** DTh cools to 70°F (21°C) or lower, EvapFM energizes.
- a2) **RFH1-SSB-HD Freezer–LEDs 4 (Comp and ConFM) and 5 (CPH and DrH (auxiliary code Q-5 and later)) are on. LED 3 (EvapFM on) is off:** DTh cools to 70°F (21°C) or lower, EvapFM energizes.

(4) Defrost Completion

1a) **Freezer (auxiliary code P-6 and later)–LEDs 4 (Comp) and 5 (ConFM) are on. LED 3 (EvapFM on) is off:** When CTh reads 15°F (8.3°C) above setpoint or less, cabinet temperature is displayed on DB. Defrost is complete.

1b) **FH1-SSB-HD Freezer–LEDs 4 (Comp and ConFM) and 5 (CPH and DrH (auxiliary code Q-5 and later)) are on. LED 3 (EvapFM on) is off:** When CTh reads 15°F (8.3°C) above setpoint or less, cabinet temperature is displayed on DB. Defrost is complete.

Legend: **CB**–control board; **Comp**–compressor; **ConFM**–condenser fan motor; **CordH**–cord heater; **CPH**–condensate pan heater; **CTh**–cabinet thermistor; **DB**–display board; **DctH**–duct heater; **DH**–defrost heater; **DrH**–drain heater; **DT**–defrost timer; **DTh**–defrost thermistor; **EvapFM**–evaporator fan motor; **MH**–mullion heater; **PH**–perimeter heater

## 2. Sequence Flow Chart

### a) Refrigerator

#### "RI-A" Control Board Refrigerator Sequence Flow Chart

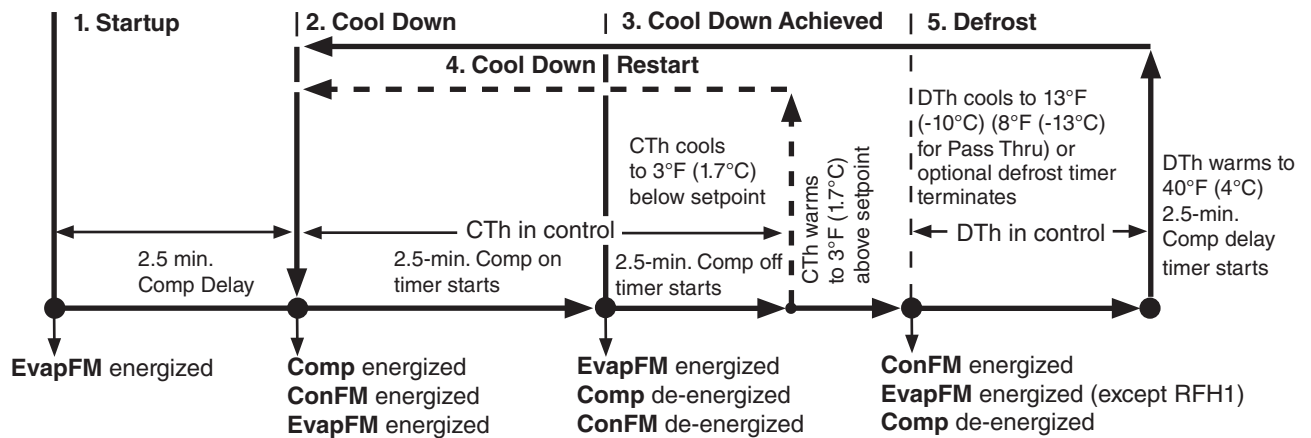

Note:

- 2.5-minute minimum compressor on and off time.
- Evaporator fan motor de-energizes when door is open.
- 20-minute minimum defrost time.
- Perimeter heater controlled by perimeter heater switch.
- Glass door (-GD models) heater controlled by glass door heater switch.
- RFH1-SSB(-HS)(-HSE): Condensate pump motor has power supply as soon as the power switch is placed in the "ON" position. Condensate pump motor energizes as needed via the float switch.

**Legend:**

**Comp**-compressor  
**ConFM**-condenser fan motor  
**CTh**-cabinet thermistor  
**DTh**-defrost thermistor  
**EvapFM**-evaporator fan motor

b) Freezer

## "RI-A" Control Board Freezer Sequence Flow Chart

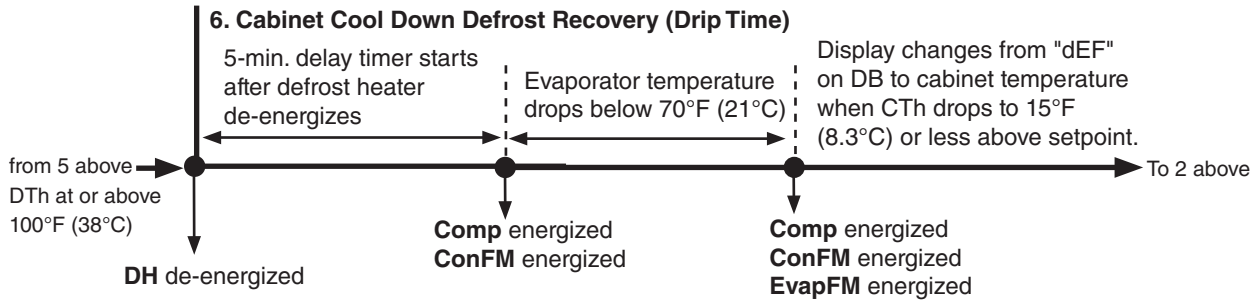
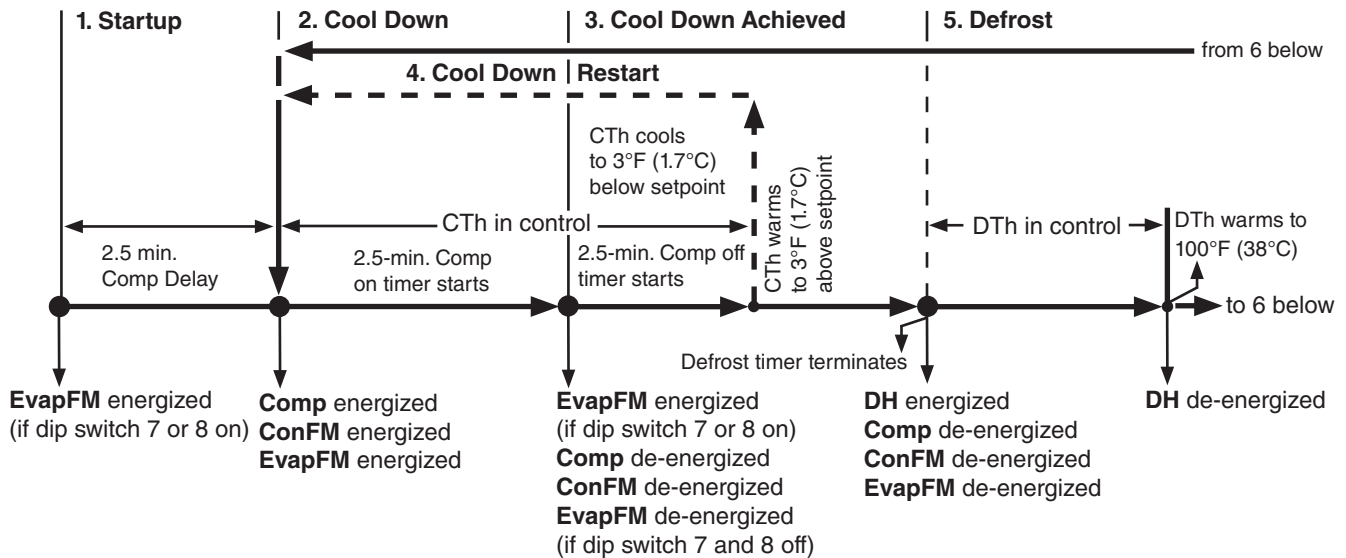

<b>Legend:</b>
<b>Comp</b> -compressor
<b>ConFM</b> -condenser fan motor
<b>CTh</b> -cabinet thermistor
<b>DB</b> -display board
<b>DH</b> -defrost heater
<b>DTh</b> -defrost thermistor
<b>EvapFM</b> -evaporator fan motor

**Note:**

- 2.5-minute minimum compressor on and off time.
- Evaporator fan motor de-energizes when door is open.
- 20-minute minimum defrost time.
- 1-hour maximum defrost time.
- Perimeter heater controlled by perimeter heater switch (except RFH1-SSB(-HS)(-HSE)).
- Glass door (-GD models) heater controlled by glass door heater switch.
- RFH1-SSB(-HS)(-HSE): Perimeter heater and mullion heater are controlled through the control board and turn on and off with compressor when S3 dip switch 8 is in the off position.
- Models may utilize any combination of the following heaters: Condensate Pan Heater, Cord Heater, Drain Heater, Duct Heater, and Glass Tube Heater. See "VII.Wiring Diagrams" for specific model details.

## C. Display Board

### 1. Location

When the power switch is moved to the "ON" position, the control board revision appears on the display board. "r ##" indicates the control board revision level (e.g., r 23). Afterward, the cabinet temperature is displayed. The display board also allows for access to the guarded access menu and service menu. From the guarded access menu, the cabinet setpoint, defrost frequency, and temperature display scale can be adjusted. For further details, see "II.E.1. Guarded Access Menu." From the service menu, information regarding appliance functions can be obtained. For further details, see "II.E.2. Service Menu."

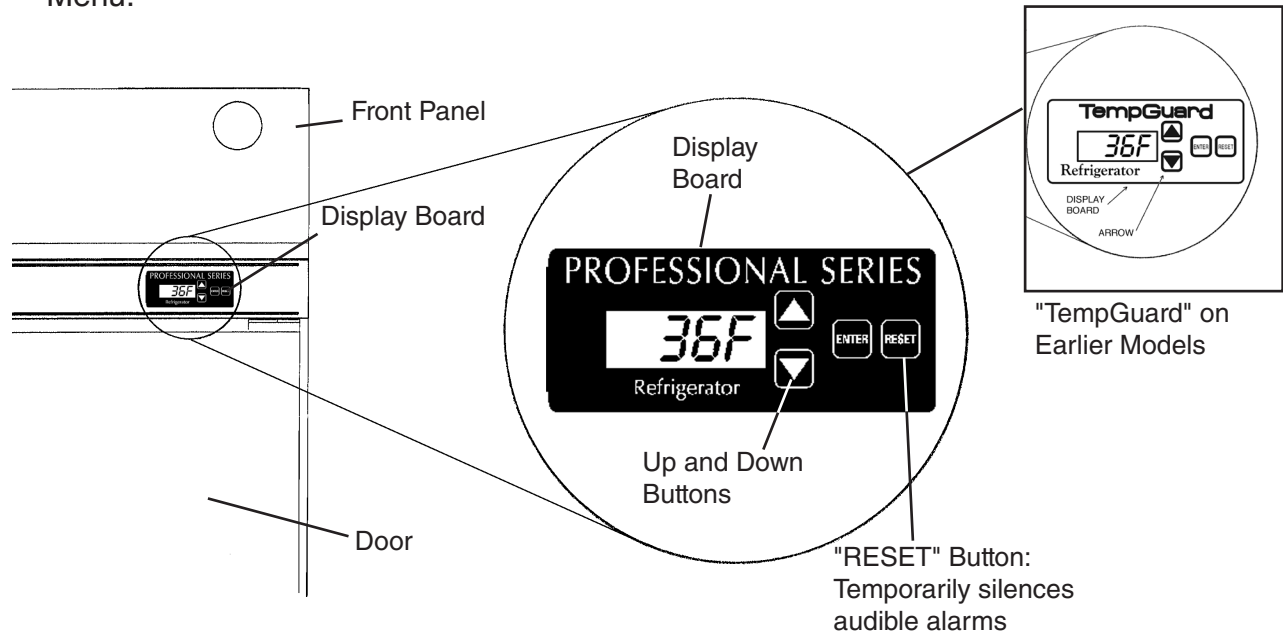

### 2. Display Board Layout

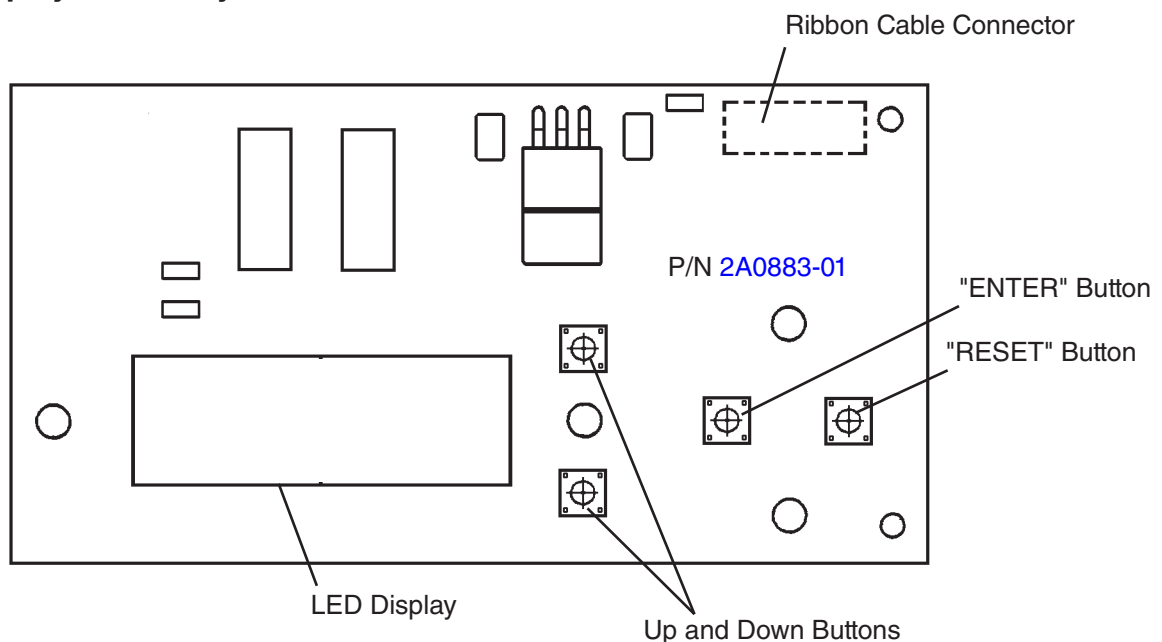

## D. Control Board

- A Hoshizaki exclusive control board is employed in Hoshizaki Professional and TempGuard Series refrigerators and freezers.
- All models are pretested and factory-adjusted.
- For a control board check procedure, see "III.B. Control Board Check."

### NOTICE

- The control board is fragile; handle very carefully.
- The control board contains integrated circuits, which are susceptible to failure due to static discharge. It is especially important to touch the metal part of the appliance before handling or replacing the control board.
- Do not touch the electronic devices on the control board or the back of the control board.
- Do not change wiring and connections. Do not misconnect terminals.
- Do not short out power supply to test for voltage.
- Always replace the whole control board assembly if it goes bad.
- Keep the thermistor, clogged filter, door switch, and high-pressure switch leads and ribbon cable at least 1 1/2" away from high voltage leads (100VAC or more) to protect against electrical noise.

### 1. Location

The control box, control panel, and error code label are located behind the front panel. There are two front panel designs. If the front panel swings up when pulled out, swing the panel up and allow both panel hinges to catch securely on both sides of the side panel frame (one on each side). Otherwise, remove the panel by lifting it up approximately one-half inch, then pulling it forward.

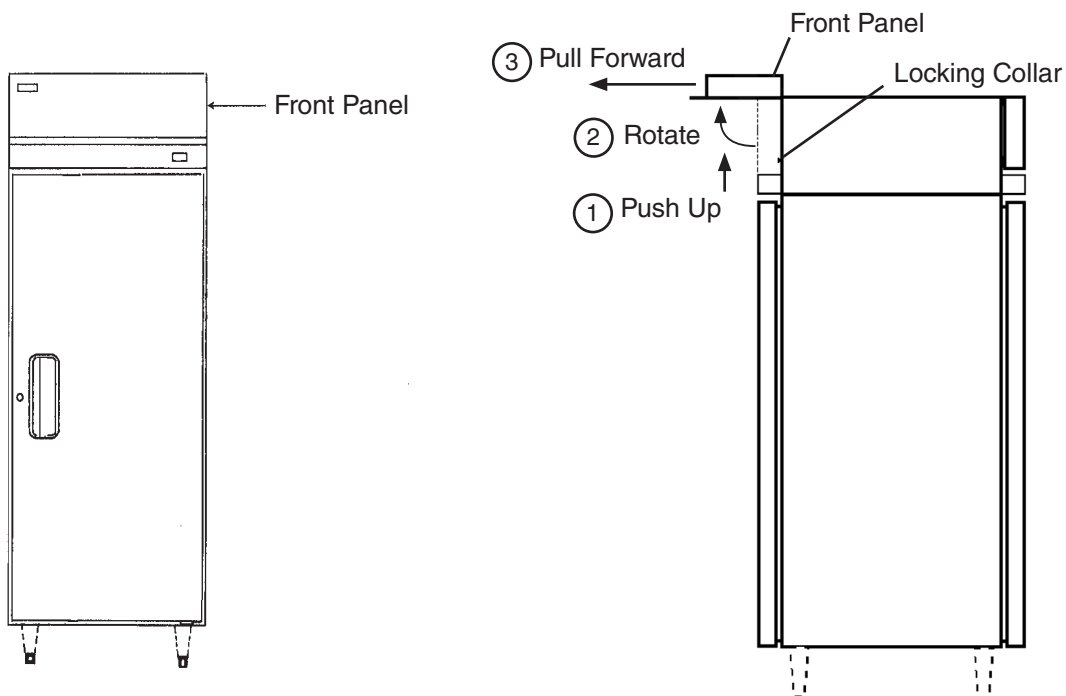

## 2. Control Board Layout

### "RI-A" Control Board

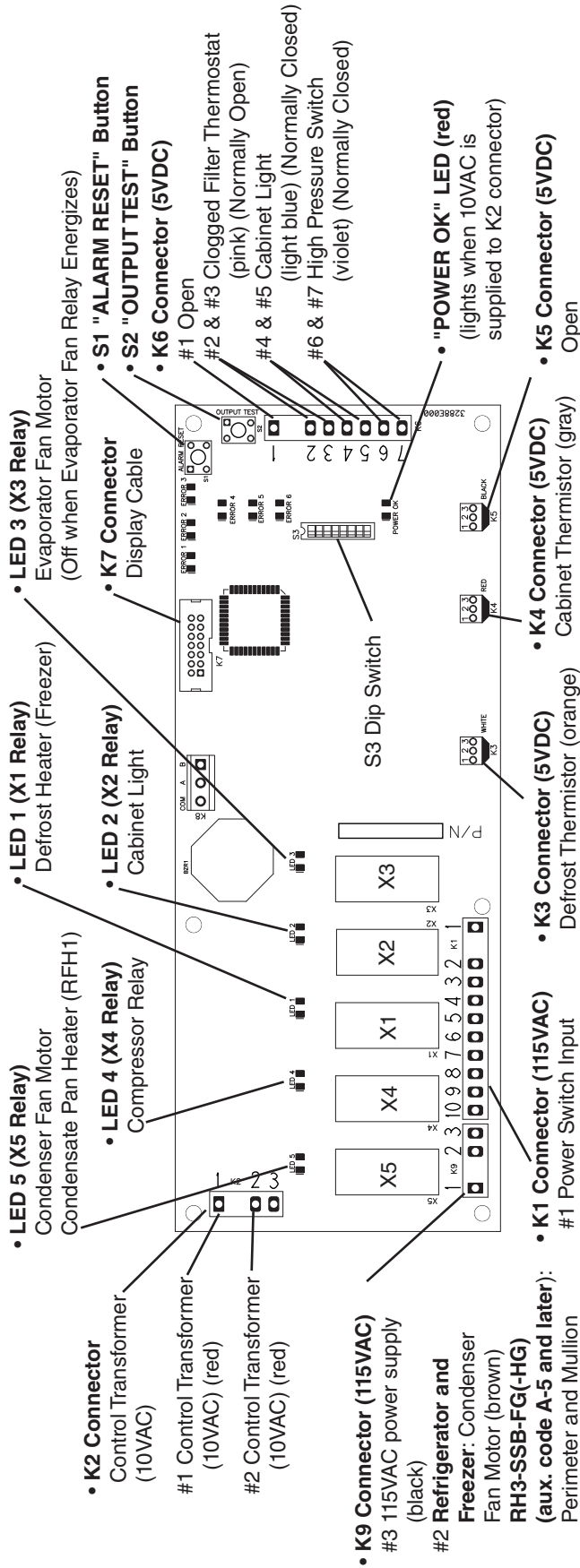

Relay	LED	Component Energized	LED ON/OFF
X1	1	Defrost Heater (Freezer)	ON
X2	2	Cabinet Light	ON
X3	3	Evaporator Fan Motor	OFF
X4	4	Compressor Relay	ON
X5	5	Condenser Fan Motor Condensate Pan Heater (RFH1)	ON

<b>"RI-A" Control Board</b>	
Part Number	<a href="#">2A2862-24</a>

## E. Controls and Adjustments

### 1. Guarded Access Menu

Three settings can be viewed and adjusted from this menu: temperature setpoint, defrost frequency, and temperature display scale. To enter the guarded access menu, press and hold the up and down buttons simultaneously for 3 seconds. The current setpoint temperature is displayed.

#### a) Temperature Setpoint

The refrigerator factory default setting is 36°F (2°C).

The freezer factory default setting is -3°F (-19°C).

The temperature setpoint is the value for the average cabinet temperature. The temperature differential for the compressor to turn on and off is  $\pm 3^\circ\text{F}$  of the setpoint. For example, setpoint = 36°F, compressor on at 39°F, compressor off at 33°F. If necessary, adjust the setpoint temperature as follows:

- 1) Press and hold the up/down arrows simultaneously for 3 seconds. The current setpoint temperature will be displayed.
- 2) To change the setpoint, press the up/down arrows until the desired value is displayed. For refrigerators the cabinet temperature is adjustable between 36°F and 50°F (2°C and 10°C). The factory default is 36°F (2°C). For freezers the cabinet temperature is adjustable between -10°F and 25°F (-23°C and -3°C). The factory default is -3°F (-19°C).
- 3) To save the value, press "ENTER" repeatedly until you have cycled through the menu and the appliance returns to the normal display mode. If you do not cycle through the menu and no button is pressed in 15 seconds, the display will return to normal and the setpoint will remain unchanged.

#### b) Defrost Frequency

##### (1a) Defrost for Refrigerators - Control Board Revision 22 and earlier

This appliance uses an off-cycle defrost. When a sensor in the evaporator coil reaches 13°F (-10°C) (8°F, (-13°C) for Pass Thru) the appliance enters defrost. When the sensor reaches 40°F (4°C) the appliance ends defrost. No adjustment is available or needed from the control board.

The cabinet temperature is displayed, even during defrost.

##### (1b) Defrost for Refrigerators - Control Board Revision 23 and later

This appliance uses an off-cycle defrost. When a sensor in the evaporator coil reaches 13°F (-10°C) (8°F, (-13°C) for Pass Thru) the appliance enters defrost. When the sensor reaches 40°F (4°C) the appliance ends defrost. The cabinet temperature is not displayed during defrost, "dEF" is displayed in its place. This revision also feature an adjustable time-initiated defrost along with the normal temperature-initiated defrost.

The time-initiated defrost is factory set at 0. Before changing this setting, contact the Hoshizaki Technical Support Department for recommendations. To change the time-initiated defrost, follow the steps in "(3) Defrost Frequency Adjustment" later in this section.

## *(2) Defrost for Freezer*

This appliance uses a time-initiated heated defrost. It is preset at the factory to defrost 6 times per day for general conditions. However, if it is determined that this interval does not suit conditions, the interval can be changed. To change, see "(3) Defrost Frequency Adjustment" below. Contact the Hoshizaki Technical Support Department for recommendations. Note that since the defrost is heated, it will have a tendency to raise cabinet temperature. Defrost termination temperature is 100°F (38°C).

During freezer defrost, the cabinet temperature is not displayed, "dEF" is displayed in its place.

## *(3) Defrost Frequency Adjustment*

- 1) Press and hold the up/down arrows simultaneously for 3 seconds. Press "ENTER" until "dF" is displayed.
- 2) To change the time-initiated defrost frequency, press the up/down arrows until the desired value is displayed. For refrigerators (control board revision 23 and later), the defrost frequency is adjustable between 0 and 12 defrosts per 24 hours. For freezers, the defrost frequency is adjustable between 1 and 12 defrosts per 24 hours. The factory default for refrigerators is 0 and the factory default for freezers is 6.
- 3) To save the value, press "ENTER" repeatedly until you have cycled through the menu and the appliance returns to the normal display mode. If you do not cycle through the menu and no button is pressed in 15 seconds, the display will return to normal and the defrost frequency will remain unchanged.

Note: The change in the defrost setting will take effect after the next defrost based on the previous setting. If it is desired that this change in interval timing take effect immediately, turn the appliance off and back on. The next time-initiated defrost will take effect "x" hours after power is resupplied. For example, if the setting is dF 6, x=4 and the next defrost will take place 4 hours from the time that power is applied.

Primary defrost termination is controlled by the defrost thermistor. However, two additional safeties are also present:

- Time Termination - 1 hour maximum
- Temperature Termination - Measured by a separate device that is in-line with the heaters and independent of the control board

## **c) Temperature Display Scale (°F or °C)**

To change the display scale, follow the steps below.

- 1) Press and hold the up/down arrows simultaneously for 3 seconds. Press "ENTER" until "F" or "C" temperature display scale is displayed.
- 2) To change the temperature display, press the up/down arrows until the desired scale is displayed. The factory default is "F".
- 3) Press "ENTER" to save the value and return to normal display mode. If you do not press "ENTER" and no button is pressed in 15 seconds, the display will return to normal and the temperature display scale will remain unchanged.

## 2. Service Menu

From the service menu, information regarding the functioning of the appliance can be obtained. To access the service menu, press and hold the up and down buttons and the "ENTER" button simultaneously for 3 seconds. Scroll through the service menu list using the "ENTER" button. Change options using the up/down arrows. To exit, press the "ENTER" button until normal display mode returns. To exit the service menu at any point, press and hold the "ENTER" button for 3 seconds or the service menu display remains on the display board for 10 minutes after the last keystroke, then automatically reverts to normal operation (cabinet temperature display). All information given in degrees automatically displays in the current selected scale (°F or °C).

Display	Definition
1 OFF	Displays cabinet temperature.
1 ON	Displays evaporator temperature. Display will automatically revert to cabinet sensor after five minutes.
2 OFF (Freezer Only)	Manual defrost initiation option not activated.
2 ON (Freezer Only)	Manual defrost initiation option activated. Control will begin defrost cycle when user returns to operating mode by cycling through menus. Manual defrost does not eliminate or change times on any scheduled defrost cycles.
3 OFF	Unconditional alarm reset option not activated.
3 ON	Unconditional alarm reset option activated. Changing from 3 OFF to 3 ON resets all alarm display codes simultaneously. This is a complete clearing of alarms.
4 16	Right two digits represent compressor run time in last 24 hours to the nearest hour. Example: 16 hours total run time in the last 24 hours. Value is every 24 hours.
5 50	Right two digits represent compressor on time percentage for the last 5 run cycles. A run cycle begins when the compressor switches from off to on and ends the next time it switches from off to on. (See diagram below). Example: 50% run time over the last 5 run cycles. Value is calculated as follows: Percent on time = On time last 5 cycles/total time last 5 cycles. Value is saved every 5 cycles. Note: "On time last 5 cycles" does not include an on time that was terminated by a defrost cycle or the first on time after a defrost, and "Total time last 5 cycles" does not include an on or off time that was terminated by a defrost cycle, the time spent in defrost, or the first on time after a defrost.
6 45	Right two digits represent compressor run time for the last run cycle. Example: 45 minutes of compressor run time in last run cycle.
7 45 (Freezer Only)	Right two digits represent length of time for the last defrost cycle in minutes. Example: 45 minutes in last defrost cycle.
8 67	Right two digits represent highest temperature recorded during the last high temperature alarm. Example: Temperature reached 67 degrees during last high temperature alarm. Display will show "8--" if there has not been a high temperature alarm. Value is saved every 8.5 minutes when in alarm.
9-10	Right three places represent lowest temperature recorded during the last low temperature alarm. Example: Temperature reached -10 degrees during the last low temperature alarm. Display will show "9--" if there has not been a low temperature alarm. Value is saved every 8.5 minutes when in alarm.

### 3. LED Lights and Alarm Safeties Chart

If an error occurs, the alarm code and cabinet temperature are displayed in 2-second intervals and an alarm sounds. See the table below for a description of the problem.

Alarm Signals			
Alarm Code	Alarm Sound	Problem	Reset Options
E1	3 beeps every ten seconds	<p>High Temperature Alarm</p> <p><b>[Freezers with Control Board Revision 10 and Earlier and All Refrigerators]</b> Cabinet temperature has exceeded set temperature by 10°F (5.6°C) for more than 2 hours.</p> <p><b>[Freezers with Control Board Revision 11 and Later]</b> Cabinet temperature has exceeded set temperature by 25°F (14°C) for more than 4 hours. (When the appliance is turned on, the first display reads "r ##", where "##" indicates the control board revision.)</p>	<p>Press "RESET." If temperature has returned to setpoint range, alarm will stop and "E1" will clear.</p> <p>If temperature is not back in range, "RESET" will silence the alarm for 5 minutes. "E1" will continue to flash.</p>
E2	4 beeps every ten seconds	<p>Low Temperature Alarm</p> <p>Cabinet temperature has remained below setpoint by 8°F (4°C) for more than 1 hour.</p>	<p>Press "RESET." If temperature has returned to setpoint range, alarm will stop and "E2" will clear.</p> <p>If temperature is not back in range, "RESET" will silence the alarm for 5 minutes. "E2" will continue to flash.</p>
E3 <b>[Freezer Only]</b> (may alternate with "dEF" instead of temperature)	5 beeps every ten seconds	<p>Defrost Alarm</p> <p>Defrost has taken longer than 1 hour. Control board has terminated defrost.</p>	<p>Press "RESET." Alarm will stop and "E3" will clear.</p> <p>If 4 consecutive defrosts take more than 1 hour, a qualified service technician must be called.</p> <p>For the service tech to reset this alarm, press "ALARM RESET" on the control board itself.</p>
E4	6 beeps every ten seconds	<p>High-Pressure Alarm</p> <p>Compressor discharge pressure is outside normal operating range. High-pressure switch has been triggered 3 or more times in 1 hour.</p> <p>If the high-pressure switch trips 5 times in 1 hour, compressor stops and will not restart.</p>	<p>Press "RESET." If high-pressure switch resets automatically, alarm will stop and "E4" will clear when high-pressure switch closes. After 5 high-pressure switch trips, the alarm can be silenced for 1 hour by pressing the "RESET".</p> <p>For the service tech to reset this alarm, press "ALARM RESET" on the control board itself.</p>
E6	8 beeps every ten seconds	<p>High Voltage Alarm</p> <p>Line voltage has been too high for at least 10 seconds. To protect the compressor, the control board de-energizes the compressor.</p>	<p>Alarm automatically resets when acceptable voltage is detected.</p> <p>Press "RESET" to silence alarm for 5 minutes.</p>
E7	9 beeps every ten seconds	<p>Low Voltage Alarm</p> <p>Line voltage has been too low for at least 10 seconds. To protect the compressor, the control board de-energizes the compressor.</p>	<p>Alarm automatically resets when acceptable voltage is detected.</p> <p>Press "RESET" to silence alarm for 5 minutes.</p>

Alarm Signals			
Alarm Code	Alarm Sound	Problem	Reset Options
E8	Constant buzzer	Cabinet Thermistor Malfunction Alarm  Cabinet thermistor has failed.	Cabinet thermistor disconnected, shorted or open. Check connection and continuity. Reconnect or replace as needed. After replacing cabinet thermistor, alarm resets.  During alarm, press "RESET" to silence buzzer for 5 minutes.  Refrigerator: Compressor cycles 5 min. on, 5 min. off. Freezer: Compressor cycles 10 min. on, 3 min. off.
E9	Constant buzzer	Defrost Thermistor Malfunction Alarm  Defrost thermistor has failed.	Defrost thermistor disconnected, shorted, or open. Check connection and continuity. Reconnect or replace as needed. After replacing defrost thermistor, alarm resets.  During alarm, press "RESET" to silence buzzer for 5 minutes.  Refrigerator: Defrost cycles every 6 hr. and terminates on cabinet thermistor temperature. If cabinet thermistor is also defective, defrost last 45 min.  Freezer: Defrost cycles on programmed defrost timed intervals and terminates at 45 min.
E10 [Dual Temp Models Only]	10 beeps every ten seconds	Communication Alarm  Freezer and refrigerator control boards not communicating properly to control compressor delay.	When communication is restored, alarm will reset. During alarm, press "RESET" to silence buzzer for 18 hours.
CF	1 beep every ten seconds	Clogged Filter Alarm  Condenser filter needs cleaning.	Clean filter. Allow time for sensor to react, then press "RESET."  During alarm, press "RESET" to silence buzzer for 2 hours. <b>If this alarm occurs frequently, discharge temperature is consistently too high. Failure to take action could result in damage to the compressor.</b>
door [Except -GD Models]	2 beeps every ten seconds	Display Only: Door open. Both Display and Beeps: Door open longer than 3 minutes.	Close door. During alarm, press "RESET" to silence buzzer for 3 minutes.

Note: Moving the diagnostic menu item 3 to "ON" resets all alarms regardless of whether or not the setpoints are reached. This is a complete clearing of all alarms. See "II.E.2. Service Menu" for details.

#### 4. Default Dip Switch Settings

The S3 dip switch settings are factory-set to the following positions:

Refrigerator S3 Dip Switch								
Model	S3 Dip Switch No.							
	1	2	*3	4	5	6	7	8
RH_-SSB(-HD)(-FG)(-HG)	ON	OFF	OFF	OFF	OFF	OFF	OFF	OFF
RH_-SSB-GD	ON	ON	OFF	OFF	OFF	OFF	OFF	OFF
PTR1SSB-xxxx PTR1SSB01-10 PTR2SSB-xxxx	ON	OFF	OFF	ON	OFF	OFF	OFF	OFF
RIR_-SSB, RTR1-SSB	ON	OFF	OFF	OFF	OFF	OFF	OFF	OFF
RIR2-SSB51-02	ON	ON	OFF	OFF	OFF	OFF	OFF	OFF

Freezer S3 Dip Switch								
Model	S3 Dip Switch No.							
	1	2	*3	4	5	6	7	8
FH_-SSB(-HD) Aux. Code P-5 and Earlier	OFF	OFF	OFF	OFF	OFF	OFF	OFF	OFF
FH_-SSB(-HD) Aux. Code P-6 and Later	OFF	OFF	OFF	OFF	OFF	OFF	ON	OFF

Dual Temp S3 Dip Switch								
Model	S3 Dip Switch No.							
	1	2	*3	4	5	6	7	8
RFH_-SSB(-HD)(-HS)(-HSE) Refrigerator	ON	OFF	OFF	OFF	OFF	ON	OFF	OFF
RFH1-SSB-HD Freezer	OFF	OFF	OFF	OFF	OFF	ON	OFF	ON
RFH1-SSB(-HS)(-HSE) Freezer	OFF	OFF	OFF	OFF	OFF	ON	OFF	OFF
RFH2-SSB(-HD) Freezer Aux. Code P-5 and Earlier	OFF	OFF	OFF	OFF	OFF	ON	OFF	OFF
RFH2-SSB(-HD) Freezer Aux. Code P-6 and Later	OFF	OFF	OFF	OFF	OFF	ON	ON	OFF
RFH3-SSB(-HD) Freezer Aux. Code P-5 and Earlier	OFF	OFF	OFF	OFF	OFF	ON	OFF	OFF
RFH3-SSB(-HD) Freezer Aux. Code P-6 and Later	OFF	OFF	OFF	OFF	OFF	ON	ON	OFF

**\*NOTICE! S3 Dip Switch 3: Used to accommodate a normally open or normally closed door switch. Place in the "OFF" position for the newer square door switch, part number 3A1386-01 or [3A1826-01](#). Place in the "ON" position for the older round door switch, part number [4A0487-01](#).**

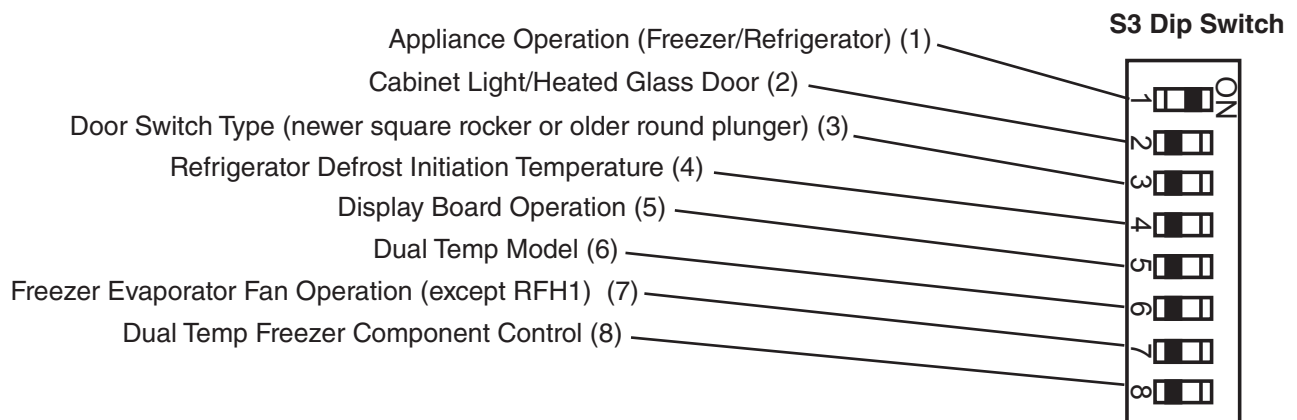

**a) Appliance Operation (Freezer/Refrigerator) (S3 dip switch 1)**

This setting determines whether the control board operates in refrigerator mode or freezer mode. It also determines the temperature setpoint range at which the appliance operates.

Factory set, no adjustment required.

S3 Dip Switch Setting	Appliance Operation	Temperature Setpoint Range	Factory Default
No. 1			
OFF	Freezer	-10°F to 25°F (-23°C to -3°C)	-3°F (-19°C)
ON	Refrigerator	36°F to 50°F (2°C to 10°C)	36°F (2°C)

**b) Cabinet Light/Heated Glass Door (S3 dip switch 2)**

When the cabinet light option is selected (S3 dip switch 2 "OFF"), the control board energizes the K1 connector pin #5 (LBU wire) and turns on the cabinet light (solid door models) each time the door and door switch open.

When the heated glass door option is selected (S3 dip switch 2 "ON"), the control board energizes the K1 connector pin #5 (LBU wire) when the compressor is off, and de-energizes when the compressor turns on.

Factory set, no adjustment required.

S3 Dip Switch Setting	Cabinet Light/Heated Glass Door
No. 2	
OFF	Cabinet Light
ON	Heated Glass Door (-GD models)

**c) Door Switch Type (S3 dip switch 3)**

Hoshizaki has utilized both normally open and normally closed door switch contact styles. S3 dip switch 3 is used to select the type of switch used on a particular model.

Factory set, no adjustment required.

S3 Dip Switch Setting	Door Switch Type (Rocker or Plunger)
No. 3	
OFF	Rocker Door Switch (square): Open Contacts when Doors are Open
ON	Plunger Door Switch (round): Closed Contacts when Doors are Open

**d) Refrigerator Defrost Initiation Temperature (S3 dip switch 4)**

Refrigerators only. Pass Thru refrigerator models require a defrost initiation temperature that is different from the reach-in refrigerator models.

Factory set, no adjustment required.

S3 Dip Switch Setting	Model	Defrost Initiation Temperature
No. 4		
OFF	All Refrigerators Except Pass Thru	13°F (-10°C)
ON	Pass Thru	8°F (-13°C)

**e) Display Board Operation (S3 dip switch 5)**

The display board may be disabled by moving S3 dip switch 5 to the "ON" position. When the display board is disabled, the control board operates in default mode.  
Default Mode: Compressor on 5-minutes, then off 5-minutes.  
Factory set, no adjustment required.

S3 Dip Switch Setting	Display Board Status
No. 5	
OFF	Enabled
ON	Disabled

**f) Dual Temp Models (S3 dip switch 6)**

Dual Temp appliances require S3 dip switch 6 be placed in the "ON" position for proper operation. **NOTICE! Do not adjust S3 dip switch 6 out of the factory default position. This dip switch must be left in the factory default position or the appliance will not operate correctly.** Factory set, no adjustment required.

S3 Dip Switch Setting	Dual Temp Selector Switch
No. 6	
OFF	All Models Except Dual Temp
ON	Dual Temp Models

**g) Freezer Evaporator Fan Operation (except RFH1) (S3 dip switch 7)**

Active when S3 dip switch 1 and S3 dip switch 8 are in the "OFF" position (freezer application). When S3 dip switch 7 is in the "ON" position, evaporator fan operates continuously (except during defrost and doors open) and the temperature at which the evaporator fan resumes after defrost changes from 0°F (-18°C) to 70°F (21°C). When set to the "OFF" position, the evaporator fan cycles on and off with the compressor. After defrost, evaporator fan resumes when evaporator temperature reaches 0°F (-18°C).  
Factory set, no adjustment required.

Note: S3 dip switch 7 is ignored when S3 dip switch 1 or S3 dip switch 8 is in the "ON" position.

S3 Dip Switch Setting	Freezer Evaporator Fan Operation
No. 7	
OFF	Evap. Fan Cycles On and Off with the Compressor After Defrost, Evap. Fan Restarts when Defrost Thermistor Reaches 0°F (-18°C)
ON	Continuous Evap. Fan (except during defrost and doors open) After Defrost, Evap. Fan Restarts when Defrost Thermistor Reaches 70°F (21°C)

**h) Dual Temp Freezer Component Control (S3 dip switch 8)**

Dual Temp only. Active when S3 dip switch 1 is in the "OFF" position (freezer application) and S3 dip switch 6 is in the "ON" position (Dual Temp application). When S3 dip switch 8 is in the "OFF" position, the component(s) on CB K9 pin #2 circuit energize and de-energize with the compressor and the evaporator fan motor cycles according to S3 dip switch 7 setting. When S3 dip switch 8 is in the "ON" position, the component(s) on CB K9 pin #2 circuit energize at the beginning of the first cool down achieved cycle and the evaporator fan motor runs continuously (except in defrost and door open).

**NOTICE! Do not adjust S3 dip switch 8 out of the factory default position. This dip switch must be left in the factory default position or the appliance will not operate correctly.** Factory set, no adjustment required.

Note: S3 dip switch 8 is ignored when S3 dip switch 1 is in the "ON" position or S3 dip switch 6 is in the "OFF" position.

Model	Components on CB K9 pin #2
RFH1-SSB-HD Freezer	Condensate Pan Heater and Drain Heater (aux. code Q-5 and later)
RFH1-SSB(-HS)(-HSE) Freezer	Drain Heater, Perimeter Heater, and Mullion Heater
RFH2-SSB(-HD) and RFH3-SSB(-HD)	Condenser Fan Motor

S3 Dip Switch Setting	Dual Temp Freezer Component Control
<b>No. 8</b>	
OFF LED 5 (X5 relay) on with LED 4 (Compressor)	All CB K9 pin #2 components cycle on and off with compressor. Evaporator fan motor defaults to S3 dip switch 7 setting.
ON LED 5 (X5 relay) delayed on until first cool down achieved then on continuously	All CB K9 pin #2 components delayed on until the beginning of the first "Cool Down Achieved" cycle and remain on until power is turned off and back on. Continuous evaporator fan motor (except in defrost and door open). After defrost, evaporator fan motor restarts when defrost thermistor reaches 0°F (-18°C)

## **F. Compressor Protector, Short Cycle Protection, and High-Pressure Switch**

### **1. Compressor External or Internal Protector**

If combined temperature/amperage value is above the limit specified by the compressor manufacturer, the compressor external or internal protector operates independently to turn off the compressor. The compressor external or internal protector de-energizes the compressor until the temperature/amperage value returns to an acceptable level.

- If the condenser fan motor is operating and the compressor is off, it is most likely that the compressor relay, external or internal protector are open.

### **2. Short-Cycle Protection**

There is a 2.5-minute minimum off-time and on-time for the compressor.

Note: Time may vary with compressor protector or high-pressure switch activation.

### **3. High-Pressure Switch**

If pressure on the high-side of the appliance exceeds Hoshizaki specifications, the high-pressure switch activates and interrupts the compressor circuit, de-energizing the compressor until the pressure returns to an acceptable level. For further details, see "III. Service Diagnosis".

## **G. Perimeter Frame Heater**

This appliance is equipped with a perimeter frame heater. This prevents the formation of condensate on the front frame of the appliance under high humidity conditions. If operating the appliance under conditions where condensate will not form, these heaters may be turned off using the switch on the control box.

## **H. Thermistors**

The cabinet thermistor is used for cabinet temperature control and the defrost thermistor is used for defrost cycle initiation and termination. Thermistor resistance varies depending on temperature. The control board monitors the resistance to control system operation. No adjustment is required. For further details, see "III.C. Thermistor Check."

## **I. Glass Door Heater**

-GD, PTR1SSB01-10, and PTR1SSB(-FGFG)(-HGHS)(-HGHG)(auxiliary code T-5 and earlier) models are equipped with door heater(s) and door heater switch. This prevents the formation of condensate on the glass under high humidity conditions. If operating appliance under conditions where condensation is not a concern, the door heater(s) may be turned off.

### III. Service Diagnosis

#### **⚠ WARNING**

- This appliance should be diagnosed and repaired only by qualified service personnel to reduce the risk of death, electric shock, serious injury, or fire.
- Risk of electric shock. Use extreme caution and exercise safe electrical practices.
- Moving parts (e.g., fan blade) can crush and cut. Keep hands clear.
- Make sure all food zones are clean after the appliance is serviced. For cleaning procedures, see "V.A. Cleaning Instructions."

#### **A. Diagnostic Procedure**

The diagnostic procedure is basically a sequence check that allows you to diagnose the electrical system and components. Before proceeding, check for correct installation, proper voltage per appliance nameplate. Check CB S3 dip switch settings to assure that they are in the factory default position. For factory default settings, see "II.E.4. Default Dip Switch Settings." The service menu may be used to view history information. To access the service menu, press and hold the up and down buttons and "ENTER" button simultaneously for 3 seconds. Scroll through the service menu list using the "ENTER" button. For further details, see "II.E.2. Service Menu." As you go through the diagnostic procedure, check to assure the components energize and de-energize correctly. If not, those components or controls are suspect. Always choose a neutral (W wire) to establish a good neutral connection when checking high voltages. CB "POWER OK" LED remains on unless power supply is interrupted.

#### **IMPORTANT**

The maximum allowable voltage variation is  $\pm 10$  percent of the nameplate rating. 115VAC is used as a reference voltage when checking voltage to components. Voltage may vary depending on power supply.

- 1) Raise the front panel and move the power switch to the "OFF" position.
- 2) Unplug the appliance from the electrical outlet.
- 3) Remove the control box cover.
- 4) Plug the appliance back into the electrical outlet.
- 5) Move the power switch to the "ON" position.
- 6) Confirm proper supply voltage (115VAC) to the power switch. There is a 5-second delay while CB identifies program revision. Revision (r ##) is shown on DB. After 5-second delay, DB shows current cabinet temperature. PH and MH energize when PH switch is on (red marking visible). **Diagnosis:** Check that red "POWER OK" LED is on. If not, verify incoming voltage supply. Check control transformer input and output voltage (115VAC input and 10VAC output voltage) and control transformer continuity. If 115VAC input and 10VAC output voltage is present, and the red "POWER

OK" LED is off, replace CB. **PH and MH Diagnosis:** Confirm PH switch is on (red marking visible). Next, check for voltage at PH switch. 115VAC should be present from both black (BK) wires to any neutral (W wire). If 115VAC is present on one and not the other, PH switch is open. Next, check PH and MH amp draw, if no amp draw is present, check the continuity of PH and MH.

Note: If CB is in alarm, see "II.E.3. LED Lights and Alarm Safeties Chart." To clear all alarms, set service menu item 3 to "ON." See "II.E.2. Service Menu" for details. Continue to "III.A.1. Refrigerator and RFH1-SSB(-HD)(-HS)(-HSE) Refrigerator," "III.A.2a. Freezer (auxiliary code P-5 and earlier) and RFH1-SSB(-HS)(-HSE) Freezer," or "III.A.2b. Freezer (auxiliary code P-6 and later) and RFH1-SSB-HD Freezer."

## 1. Refrigerator and RFH1-SSB(-HD)(-HS)(-HSE) Refrigerator

### 7) **Startup—no component LEDs are on. LED 3 (EvapFM on) is off:** EvapFM energizes.

Note: EvapFM continues unless door is opened. 2.5 minute Comp delay timer starts.

**Diagnosis:** Make sure "door" is not displayed on DB. If so, check that CB dip switch #3 is in the factory default position. See, "II.E.4.c) Door Switch Type (S3 dip switch 3)." Check door switch continuity. Next, check that EvapFM is running. If not, check EvapFM blade for binding. Check for 115VAC at CB K1 connector pin #3 (DBU wire) to a neutral (W wire). If 115VAC is not present, replace CB. If 115VAC is present, check EvapFM continuity.

### 8a) **Cool Down—Refrigerator: LEDs 4 (Comp) and 5 (ConFM) are on:** EvapFM continues.

2.5 minute Comp delay timer terminates. Comp and ConFM energize. 2.5 min. Comp minimum run timer starts.

### 8b) **Cool Down—RFH1-SSB(-HD)(-HS)(-HSE) Refrigerator: LEDs 4 (Comp and ConFM) and 5 (unused) are on:** EvapFM continues. 2.5 minute Comp delay timer terminates. Comp and ConFM energize. 2.5 min. Comp minimum run timer starts.

a) **Comp Diagnosis:** Check that Comp energizes. If Comp does not start, check for 115VAC at CB K1 connector pin #10 (GY wire) to a neutral (W wire). If 115VAC is not present, replace CB. If 115VAC is present, check for 115VAC at Comp relay black (BK wire) and red (R wire) to a neutral (W wire). If 115VAC is not present on the black (BK wire), check wiring connections. If 115VAC is present on black (BK wire) but not on the red (R wire), Comp relay contacts are open. Confirm 115VAC on Comp relay coil gray (GY wire) to a neutral (W wire). If 115VAC is present, and contacts are open, replace Comp relay. Next, if 115VAC is present on the red (R wire), check continuity of Comp overload. If overload is closed, check start capacitor, start relay, and Comp motor winding. If overload is open, let overload cool and reset. Replace if it does not reset. When overload closes, if Comp still does not start, check start capacitor, start relay, and Comp motor winding.

b1) **ConFM Diagnosis: Refrigerator:** If ConFM does not energize, check for 115VAC at CB K9 connector pin #2 (BR wire) to a neutral (W wire). If 115VAC is not present, replace CB. Next, check that the fan blade is not binding and the ConFM continuity is good.

b2) **ConFM Diagnosis: RFH1-SSB(-HD)(-HS)(-HSE) Refrigerator:** If ConFM does not energize, check for 115VAC at CB K1 connector pin #10 (GY wire) to a neutral (W wire). If 115VAC is not present, replace CB. If 115VAC is present, check for 115VAC at Comp relay black (BK wire) and red (R wire) to a neutral (W wire). If 115VAC is not present on the black (BK wire), check wiring connections. If 115VAC is present on black (BK wire) but not on the red (R wire), Comp relay contacts are open. Confirm 115VAC on Comp relay coil gray (GY wire) to a neutral (W wire). If 115VAC is present, and contacts are open, replace Comp relay. Next, check that the fan blade is not binding and the ConFM continuity is good.

c) **System Diagnosis:** If Comp, ConFM, and EvapFM are energized and the cabinet temperature is not dropping on DB, check that CTh is mounted and secured correctly. If cabinet temperature is not dropping, check for a restriction in the refrigeration circuit, correct TXV operation, and correct refrigerant charge.

9) **Cool Down Achieved—No component LEDs are on:** CTh cools to 3°F (1.7°C) below setpoint. EvapFM continues. Comp and ConFM de-energize.

a1) **Comp Diagnosis: Refrigerator:** If Comp does not de-energize, check for 115VAC at CB K1 connector pin #10 (GY wire) to a neutral (W wire). If 115VAC is present, and cabinet temperature has been met by 3°F (1.7°C) or more, replace CB. If 115VAC is not present, check continuity of Comp relay contacts. If closed, replace Comp relay.

a2) **Comp and ConFM Diagnosis: RFH1-SSB(-HD)(-HS)(-HSE) Refrigerator:** If Comp and ConFM do not de-energize, check for 115VAC at CB K1 connector pin #10 (GY wire) to a neutral (W wire). If 115VAC is present, and cabinet temperature has been met by 3°F (1.7°C) or more, replace CB. If 115VAC is not present, check continuity of Comp relay contacts. If closed, replace Comp relay.

b) **ConFM Diagnosis: Refrigerator:** If ConFM does not de-energize, check for 115VAC at CB K9 connector pin #2 (BR wire) to a neutral (W wire). If 115VAC is present, replace CB.

## 10) Refrigerator Defrost

### A1. Defrost Temperature-Initiation

1a) **Refrigerator—LED 5 (ConFM) is on. LED 3 (EvapFM on) is off:** DTh cools to 13°F (-10°C) (8°F (-13°C) for Pass-Thrus), CB initiates defrost. EvapFM continues. ConFM continues or energizes.

1b) **RFH1-SSB(-HD)(-HS)(-HSE) Refrigerator—LED 5 (unused) is on. LED 3 (EvapFM on) is off:** DTh cools to 13°F (-10°C). EvapFM continues. Comp and ConFM de-energize.

### A2. Defrost Time-Initiation

If the factory time-initiated setting is moved from 0 defrosts per 24 hours, the appliance enters the defrost cycle when the time of the new setting terminates. Defrost timer terminates, CB initiates defrost. Defrost sequence same as "10)A1. Temperature-Initiation" above.

## B. Defrost Initiation Diagnosis

- a) **Thermistor Diagnosis:** Has DTh cooled to 13°F (-10°C) (8°F (-13°C) for Pass-Thrus) or lower? Confirm DTh status, see "III.C. Thermistor Check."
- b) **Comp Diagnosis:** Confirm that Comp de-energizes. If not, check for 115VAC at K1 connector pin #10 (GY wire) to a neutral (W wire). If 115VAC is present, replace CB. If Comp is on and 115VAC is not present, check Comp relay for sticking contacts.
- c1) **ConFM Diagnosis: Refrigerator:** Check for 115VAC at CB K9 connector pin #2 (BR wire) to a neutral (W wire). If 115VAC is not present, replace CB. If 115VAC is present, check that ConFM blade is not binding and ConFM continuity is good.
- c2) **ConFM Diagnosis: RFH1-SSB(-HD)(-HS)(-HSE) Refrigerator:** Check for 115VAC at K1 connector pin #10 (GY wire) to a neutral (W wire). If 115VAC is present, replace CB. If Comp is on and 115VAC is not present, check Comp relay for sticking contacts.
- d) **EvapFM Diagnosis:** Check for 115VAC at CB K1 connector pin #3 (DBU wire) to a neutral (W wire). If 115VAC is present, check that EvapFM blade is not binding and that EvapFM continuity is good.

## C. Defrost Termination

- 1a) **Refrigerator–LEDs 4 (Comp) and 5 (ConFM) are on. LED 3 (EvapFM on) is off:** DTh warms to 40°F (4°C). EvapFM and ConFM continue. 2.5 minutes later Comp energizes.
- 1b) **RFH1-SSB(-HD)(-HS)(-HSE) Refrigerator–LEDs 4 (Comp and ConFM) and 5 (unused) are on. LED 3 (EvapFM on) is off:** DTh warms to 40°F (4°C). EvapFM continues. 2.5 minutes later Comp and ConFM energize.
  - a) **Thermistor Diagnosis:** Has DTh warmed to 40°F (4°C) or higher? Confirm DTh status, see "III.C. Thermistor Check."
  - b) **Comp Diagnosis:** Confirm that after 2.5 min. Comp delay timer terminates, CB LED 4 turns on and Comp energizes. If not, check for 115VAC at CB K1 connector pin #10 (GY wire) to a neutral (W wire). If 115VAC is not present, replace CB. If 115VAC is present, check for 115VAC at Comp relay black (BK wire) and red (R wire) to a neutral (W wire). If 115VAC is not present on the black (BK wire), check wiring connections. If 115VAC is present on black (BK wire) but not on the red (R wire), Comp relay contacts are open. Confirm 115VAC on Comp relay coil gray (GY wire) to a neutral (W wire). If 115VAC is present, and contacts are open, replace Comp relay. Next, if 115VAC is present on the red (R wire), check continuity of Comp overload. If overload is closed, check start capacitor, start relay, and Comp motor winding. If overload is open, let overload cool and reset. Replace if it does not reset. When overload closes, if Comp still does not start, check start capacitor, start relay, and Comp motor winding.
  - c1) **ConFM Diagnosis: Refrigerator:** If ConFM is not energized, check that LED 5 is on. Next, check for 115VAC at CB K9 connector pin #2 (BR wire) to a neutral (W wire). If 115VAC is not present, replace CB. If 115VAC is present, check that ConFM blade is not binding and ConFM continuity is good.

- c2) **ConFM Diagnosis: RFH1-SSB(-HD)(-HS)(-HSE) Refrigerator:** If ConFM does not energize, check for 115VAC at CB K1 connector pin #10 (GY wire) to a neutral (W wire). If 115VAC is not present, replace CB. If 115VAC is present, check for 115VAC at Comp relay black (BK wire) and red (R wire) to a neutral (W wire). If 115VAC is not present on the black (BK wire), check wiring connections. If 115VAC is present on black (BK wire) but not on the red (R wire), Comp relay contacts are open. Confirm 115VAC on Comp relay coil gray (GY wire) to a neutral (W wire). If 115VAC is present, and contacts are open, replace Comp relay.
- d) **EvapFM Diagnosis:** Check that EvapFM is running. If not, check for 115VAC at CB K1 connector pin #3 (DBU wire) to a neutral (W wire). If 115VAC is not present, replace CB. If 115VAC is present, check EvapFM blade for binding and EvapFM continuity.

Legend: **CB**—control board; **ConFM**—condenser fan motor; **Comp**—compressor;  
**CTh**—cabinet thermistor; **DB**—display board; **DTh**—defrost thermistor;  
**EvapFM**—evaporator fan motor; **MH**—mullion heater; **PH**—perimeter heater;  
**TXV**—thermostatic expansion valve

## 2a. Freezer (auxiliary code P-5 and earlier) and RFH1-SSB(-HS)(-HSE) Freezer

- 7) **Startup–LED 3 (EvapFM off) is on:** 2.5 min. Comp delay timer starts. Cabinet temperature appears on DB.
- 8a) **Cool Down–Freezer (auxiliary code P-5 and earlier): LEDs 4 (Comp) and 5 (ConFM) are on. LED 3 (EvapFM on) is off:** 2.5 min. Comp delay timer terminates. Comp, ConFM, and EvapFM energize. 2.5 min. Comp minimum run timer starts.
- 8b) **Cool Down–RFH1-SSB(-HS)(-HSE) Freezer: LEDs 4 (Comp and ConFM) and 5 (DrH, PH, and MH) are on. LED 3 (EvapFM on) is off:** 2.5 min. Comp delay timer terminates. Comp, ConFM, EvapFM, DrH, PH, and MH energize. 2.5 min. Comp minimum run timer starts.
  - a) **Comp Diagnosis:** Check that Comp energizes. If Comp does not energize, check for 115VAC at CB K1 connector pin #10 (GY wire) to a neutral (W wire). If 115VAC is not present, replace CB. If 115VAC is present, check for 115VAC at Comp relay black (BK wire) and red (R wire) to a neutral (W wire). If 115VAC is not present on the black (BK wire), check wiring connections. If 115VAC is present on black (BK wire) but not on the red (R wire), Comp relay contacts are open. Confirm 115VAC on Comp relay coil gray (GY wire) to a neutral (W wire). If 115VAC is present, and contacts are open, replace Comp relay. Next, if 115VAC is present on the red (R wire), check continuity of Comp overload. If overload is closed, check start capacitor, start relay, and Comp motor winding. If overload is open, let overload cool and reset. Replace overload if it does not reset. When overload closes, if Comp still does not start, check start capacitor, start relay, and Comp motor winding.
  - b1) **ConFM Diagnosis: Freezer (auxiliary code P-5 and earlier):** If ConFM does not energize, check for 115VAC at CB K9 connector pin #2 (BR wire) to a neutral (W wire). If 115VAC is not present, replace CB. Next, check that the fan blade is not binding and that ConFM continuity is good.
  - b2) **ConFM Diagnosis: RFH1-SSB(-HS)(-HSE) Freezer:** If ConFM does not energize, check for 115VAC at CB K1 connector pin #10 (GY wire) to a neutral (W wire). If 115VAC is not present, replace CB. If 115VAC is present, check for 115VAC at Comp relay black (BK wire) and red (R wire) to a neutral (W wire). If 115VAC is not present on the black (BK wire), check wiring connections. If 115VAC is present on black (BK wire) but not on the red (R wire), Comp relay contacts are open. Confirm 115VAC on Comp relay coil gray (GY wire) to a neutral (W wire). If 115VAC is present, and contacts are open, replace Comp relay. Next, check that the fan blade is not binding and that ConFM continuity is good.
  - c) **EvapFM Diagnosis:** If EvapFM does not energize, make sure "door" is not displayed on DB. If so, check that CB dip switch #3 is in the factory default position. See, "II.E.4.c) Door Switch Type (S3 dip switch 3)." Check door switch continuity. Next, check for 115VAC at CB K1 connector pin #3 (DBU wire) to a neutral (W wire). If 115VAC is not present, replace CB. If 115VAC is present, check EvapFM blade for binding and EvapFM continuity.

- d) **DrH, PH, and MH Diagnosis: RFH1-SSB(-HS)(-HSE) Freezer:** If heaters do not energize, check for 115VAC at CB K9 connector pin #2 (BR wire) to a neutral (W wire). If 115VAC is not present, replace CB. If 115VAC is present, check PH/MH switch. Next, check continuity of heaters.
  - e) **System Diagnosis:** If Comp, ConFM, and EvapFM are energized and the cabinet temperature is not dropping on DB, check that CTh is mounted and secured correctly. If cabinet temperature is not dropping, check for a restriction in the refrigeration circuit, correct TXV operation, and correct refrigerant charge.
- 9) **Cool Down Achieved—LED 3 (EvapFM off) is on:** CTh cools to 3°F (1.7°C) below setpoint. Comp, ConFM, EvapFM de-energize on all freezers. DrH, PH, and MH de-energize on RFH1-SSB(-HS)(-HSE).
- a) **Comp Diagnosis:** If Comp does not de-energize, check for 115VAC at CB K1 connector pin #10 (GY wire) to a neutral (W wire). If 115VAC is present, and cabinet temperature has been met by 3°F (1.7°C) or more, replace CB. If 115VAC is not present, check continuity of Comp relay contacts. If closed, replace Comp relay.
  - b1) **ConFM Diagnosis: Freezer (auxiliary code P-5 and earlier):** If ConFM does not de-energize, check for 115VAC at CB K9 connector pin #2 (BR wire) to a neutral (W wire). If 115VAC is present, replace CB.
  - b2) **ConFM Diagnosis: RFH1-SSB(-HS)(-HSE) Freezer:** If ConFM does not de-energize, check for 115VAC at CB K1 connector pin #10 (GY wire) to a neutral (W wire). If 115VAC is present, and cabinet temperature has been met by 3°F (1.7°C) or more, replace CB. If 115VAC is not present, check continuity of Comp relay contacts. If closed, replace Comp relay.
  - c) **EvapFM Diagnosis:** If EvapFM does not de-energize, check for 115VAC at CB K1 connector pin #3 (DBU wire) to a neutral (W wire). If 115VAC is present, replace CB.
  - d) **DrH, PH, and MH Diagnosis: RFH1-SSB(-HS)(-HSE) Freezer:** If heaters do not de-energize, check for 115VAC at CB K9 connector pin #2 (BR wire) to a neutral (W wire). If 115VAC is present, replace CB.
- 10) **Defrost—Freezer (auxiliary code P-5 and earlier) and RFH1-SSB(-HS)(-HSE) Freezer**

#### A. Defrost Initiation

- 1a) **Freezer (auxiliary code P-5 and earlier)—LEDs 1 (DH) and 3 (EvapFM off) are on:** DT terminates or manual defrost initiated. 20-minute minimum defrost timer starts. 1-hour maximum defrost timer starts. DH energizes. "dEF" displayed on DB. If energized, Comp, ConFM, EvapFM de-energize.
- 1b) **RFH1-SSB(-HS)(-HSE) Freezer—LEDs 1 (DH) and 3 (EvapFM off) are on:** DT terminates or manual defrost initiated. 20-minute minimum defrost timer starts. 1-hour maximum defrost timer starts. DH energizes. "dEF" displayed on DB. If energized, Comp, ConFM, and EvapFM de-energize. DrH, PH, and MH de-energize.

The time-initiated defrost is factory set to 6 times per day (every 4 hours. For further details, see "II.E.1.b) Defrost Frequency." Before changing this setting, contact Hoshizaki Technical Support at 1-800-233-1940 for recommendations.

- a) **Checkout:** Has DT terminated? Is "dEF" displayed on DB? Check that DH energizes and Comp, ConFM, and EvapFM de-energize.
- b) **DH Diagnosis:** Check for 115VAC at CB K1 connector pin #6 (O wire) to a neutral (W wire). If 115VAC is not present, confirm that the appliance is not in the 5-minute defrost recovery period. Wait 5 minutes, then check CB K1 connector pin #6 (O wire) to a neutral (W wire) again. If 115VAC is not present, and Comp is not energized, replace CB. If 115VAC is present, confirm DH amperage and continuity.
- c) **Comp Diagnosis:** If Comp does not de-energize, check for 115VAC at CB K1 connector pin #10 (GY wire) to a neutral (W wire). If 115VAC is present, replace CB. If 115VAC is not present, check continuity of Comp relay contacts. If closed, replace Comp relay.
- d1) **ConFM Diagnosis: Freezer (auxiliary code P-5 and earlier):** If ConFM does not de-energize, check for 115VAC at CB K9 connector pin #2 (BR wire) to a neutral (W wire). If 115VAC is present, replace CB.
- d2) **ConFM Diagnosis: RFH1-SSB(-HS)(-HSE) Freezer:** If ConFM does not de-energize, check for 115VAC at CB K1 connector pin #10 (GY wire) to a neutral (W wire). If 115VAC is present, replace CB. If 115VAC is not present, check continuity of Comp relay contacts. If closed, replace Comp relay.
- e) **EvapFM Diagnosis:** If EvapFM does not de-energize, check for 115VAC at CB K1 connector pin #3 (DBU wire) to a neutral (W wire). If 115VAC is present, replace CB.
- f) **DrH, PH, and MH Diagnosis: RFH1-SSB(-HS)(-HSE) Freezer:** If heaters do not de-energize, check for 115VAC at CB K9 connector pin #2 (BR wire) to a neutral (W wire). If 115VAC is present, replace CB.

## B. Defrost Termination: Defrost Recovery Step 1

- 1a) **Freezer (auxiliary code P-5 and earlier)–LEDs 3 (EvapFM off), 4 (Comp), and 5 (ConFM) are on:** DTh warms to 100°F (38°C). DH de-energizes. 5 minutes later, Comp and ConFM energize.
- 1b) **RFH1-SSB(-HS)(-HSE) Freezer–LEDs 3 (EvapFM off), 4 (Comp and ConFM), and 5 (DrH, PH, and MH) are on:** DTh warms to 100°F (38°C). DH de-energizes. 5 minutes later, Comp, ConFM, DrH, PH, and MH energize.
  - a) **Checkout:** Has DTh warmed to 100°F (38°C) or higher? Check that DH de-energizes.
  - b) **DH Diagnosis:** Check for 115VAC at CB K1 connector pin #6 (O wire) to a neutral (W wire). If 115VAC is not present, confirm that the appliance is not in the 5-minute defrost recovery period. Wait 5 minutes, then check CB K1 connector pin #6 (O wire) to a neutral (W wire) again. If 115VAC is not present, and Comp is not energized, replace CB. If 115VAC is present, confirm DH amperage. If amperage is not present, check defrost thermostat and DH continuity. If amperage is present, confirm that evaporator warms to 100°F (38°C) at DTh location. Next, check DTh status. See "III.C. Thermistor Check." When DTh reaches 100°F (38°C), DH de-energizes. If DH remains energized past 100°F (38°C), replace CB.

- c) **Comp Diagnosis:** After 5 min. confirm that Comp energizes. If Comp does not energize, check for 115VAC at CB K1 connector pin #10 (GY wire) to a neutral (W wire). If 115VAC is not present, replace CB. If 115VAC is present, check for 115VAC at Comp relay black (BK wire) and red (R wire) to a neutral (W wire). If 115VAC is not present on the black (BK wire), check wiring connections. If 115VAC is present on black (BK wire) but not on the red (R wire), Comp relay contacts are open. Confirm 115VAC on Comp relay coil gray (GY wire) to a neutral (W wire). If 115VAC is present, and contacts are open, replace Comp relay. Next, if 115VAC is present on the red (R wire), check continuity of Comp overload. If overload is closed, check start capacitor, start relay, and Comp motor winding. If overload is open, let overload cool and reset. Replace overload if it does not reset. When overload closes, if Comp still does not start, check start capacitor, start relay, and Comp motor winding.
- d1) **ConFM Diagnosis: Freezer (auxiliary code P-5 and earlier):** If ConFM does not energize, check for 115VAC at CB K9 connector pin #2 (BR wire) to a neutral (W wire). If 115VAC is not present, replace CB. Next, check that the fan blade is not binding and that ConFM continuity is good.
- d2) **ConFM Diagnosis: RFH1-SSB(-HS)(-HSE) Freezer:** If ConFM does not energize, check for 115VAC at CB K1 connector pin #10 (GY wire) to a neutral (W wire). If 115VAC is not present, replace CB. If 115VAC is present, check for 115VAC at Comp relay black (BK wire) and red (R wire) to a neutral (W wire). If 115VAC is not present on the black (BK wire), check wiring connections. If 115VAC is present on black (BK wire) but not on the red (R wire), Comp relay contacts are open. Confirm 115VAC on Comp relay coil gray (GY wire) to a neutral (W wire). If 115VAC is present, and contacts are open, replace Comp relay. Next, check that the fan blade is not binding and that ConFM continuity is good.
- e) **DrH, PH, and MH Diagnosis: RFH1-SSB(-HS)(-HSE) Freezer:** If heaters do not energize, check for 115VAC at CB K9 connector pin #2 (BR wire) to a neutral (W wire). If 115VAC is not present, replace CB. If 115VAC is present, check PH/MH switch. Next, check continuity of heaters

### C. Defrost Termination: Defrost Recovery Step 2

- 1a) **Freezer (auxiliary code P-5 and earlier)–LEDs 4 (Comp) and 5 (ConFM) are on. LED 3 (EvapFM on) off:** DTh cools to 70°F (21°C) or lower, EvapFM energizes.
- 1b) **RFH1-SSB(-HS)(-HSE) Freezer–LEDs 4 (Comp and ConFM) and 5 (DrH, PH, and MH) are on. LED 3 (EvapFM on) off:** DTh cools to 70°F (21°C) or lower, EvapFM energizes.
- a) **EvapFM Diagnosis:** Confirm evaporator temperature is at or below 70°F (21°C). Check DTh status. See "III.C. Thermistor Check." If EvapFM does not energize, make sure "door" is not displayed on DB. If so, check that CB dip switch #3 is in the factory default position. See "II.E.4.c) Door Switch Type (S3 dip switch 3)." Check door switch continuity. Next, check for 115VAC at CB K1 connector pin #3 (DBU wire) to a neutral (W wire). If 115VAC is not present, replace CB. If 115VAC is present, check EvapFM blade for binding and EvapFM continuity.

## D. Defrost Termination: Defrost Completion

1a) **Freezer (auxiliary code P-5 and earlier)—LEDs 4 (Comp) and 5 (ConFM) are on. LED 3 (EvapFM on) off:** When CTh reads 15°F (8.3°C) above setpoint or less, cabinet temperature is displayed on DB. Defrost is complete.

1b) **RFH1-SSB(-HS)(-HSE) Freezer—LEDs 4 (Comp and ConFM) and 5 (DrH, PH, and MH) are on. LED 3 (EvapFM on) off:** When CTh reads 15°F (8.3°C) above setpoint or less, cabinet temperature is displayed on DB. Defrost is complete.

Legend: **CB**—control board; **ConFM**—condenser fan motor; **Comp**—compressor; **CTh**—cabinet thermistor; **DB**—display board; **DH**—defrost heater; **DrH**—drain heater; **DT**—defrost thermostat; **DTh**—defrost thermistor; **EvapFM**—evaporator fan motor; **MH**—mullion heater; **PH**—perimeter heater; **TXV**—thermostatic expansion valve

### 2b. Freezer (auxiliary code P-6 and later) and RFH1-SSB-HD Freezer

7) **Startup—No component LEDs are on. LED 3 (EvapFM on) is off:** EvapFM energizes. 2.5 min. Comp delay timer starts. Cabinet temperature appears on DB.

a) **EvapFM Diagnosis:** If EvapFM does not energize, make sure "door" is not displayed on DB. If so, check that CB dip switch #3 is in the factory default position. See, "II.E.4.c) Door Switch Type (S3 dip switch 3)." Check door switch continuity. Next, check for 115VAC at CB K1 connector pin #3 (DBU wire) to a neutral (W wire). If 115VAC is not present, replace CB. If 115VAC is present, check EvapFM blade for binding and EvapFM continuity.

8a) **Cool Down—Freezer: LEDs 4 (Comp) and 5 (ConFM) are on (except RFH1-SSB-HD). LED 3 (EvapFM on) is off:** 2.5 min. Comp delay timer terminates. EvapFM continues. Comp and ConFM, energize. 2.5 min. Comp minimum run timer starts.

8b) **Cool Down—RFH1-SSB-HD Freezer: LED 4 (Comp and ConFM) is on. LED 3 (EvapFM on) is off. LED 5 (CPH and DrH) is on after first cool down cycle:** 2.5 min. Comp delay timer terminates. EvapFM continues. CPH and DrH continue (after first cool down cycle). Comp and ConFM, energize. 2.5 min. Comp minimum run timer starts.

a) **Comp Diagnosis:** Check that Comp energizes. If Comp does not energize, check for 115VAC at CB K1 connector pin #10 (GY wire) to a neutral (W wire). If 115VAC is not present, replace CB. If 115VAC is present, check for 115VAC at Comp relay black (BK wire) and red (R wire) to a neutral (W wire). If 115VAC is not present on the black (BK wire), check wiring connections. If 115VAC is present on black (BK wire) but not on the red (R wire), Comp relay contacts are open. Confirm 115VAC on Comp relay coil gray (GY wire) to a neutral (W wire). If 115VAC is present, and contacts are open, replace Comp relay. Next, if 115VAC is present on the red (R wire), check continuity of Comp overload. If overload is closed, check start capacitor, start relay, and Comp motor winding. If overload is open, let overload cool and reset. Replace overload if it does not reset. When overload closes, if Comp still does not start, check start capacitor, start relay, and Comp motor winding.

- b1) **ConFM Diagnosis: Freezer (auxiliary code P-6 and later):** If ConFM does not energize, check for 115VAC at CB K9 connector pin #2 (BR wire) to a neutral (W wire). If 115VAC is not present, replace CB. Next, check that the fan blade is not binding and that ConFM continuity is good.
- b2) **ConFM Diagnosis: RFH1-SSB-HD Freezer:** If ConFM does not energize, check for 115VAC at CB K1 connector pin #10 (GY wire) to a neutral (W wire). If 115VAC is not present, replace CB. If 115VAC is present, check for 115VAC at Comp relay black (BK wire) and red (R wire) to a neutral (W wire). If 115VAC is not present on the black (BK wire), check wiring connections. If 115VAC is present on black (BK wire) but not on the red (R wire), Comp relay contacts are open. Confirm 115VAC on Comp relay coil gray (GY wire) to a neutral (W wire). If 115VAC is present, and contacts are open, replace Comp relay. Next, check that the fan blade is not binding and that ConFM continuity is good.
- c) **System Diagnosis:** If Comp, ConFM, and EvapFM are energized and the cabinet temperature is not dropping on DB, check that CTh is mounted and secured correctly. If cabinet temperature is not dropping, check for a restriction in the refrigeration circuit, correct TXV operation, and correct refrigerant charge.
- 9a) **Cool Down Achieved–Freezer (auxiliary code P-6 and later): No component LEDs are on. LED 3 (EvapFM on) is off:** CTh cools to 3°F (1.7°C) below setpoint. EvapFM continues. Comp and ConFM de-energize.
- 9b) **Cool Down Achieved–RFH1-SSB-HD Freezer: LED 5 (CPH and DrH) is on. LED 3 (EvapFM on) is off.** CTh cools to 3°F (1.7°C) below setpoint. EvapFM continues. CPH and DrH energize and remain energized until power is turned off. Comp and ConFM de-energize.
- a) **Comp Diagnosis:** If Comp does not de-energize, check for 115VAC at CB K1 connector pin #10 (GY wire) to a neutral (W wire). If 115VAC is present, and cabinet temperature has been met by 3°F (1.7°C) or more, replace CB. If 115VAC is not present, check continuity of Comp relay contacts. If closed, replace Comp relay.
- b1) **ConFM Diagnosis: Freezer (auxiliary code P-6 and later):** If ConFM does not de-energize, check for 115VAC at CB K9 connector pin #2 (BR wire) to a neutral (W wire). If 115VAC is present, replace CB.
- b2) **ConFM Diagnosis: RFH1-SSB-HD Freezer:** If ConFM does not de-energize, check for 115VAC at CB K1 connector pin #10 (GY wire) to a neutral (W wire). If 115VAC is present, and cabinet temperature has been met by 3°F (1.7°C) or more, replace CB. If 115VAC is not present, check continuity of Comp relay contacts. If closed, replace Comp relay.
- c) **CPH and DrH Diagnosis: RFH1-SSB-HD Freezer:** If heaters do not energize, check for 115VAC at CB K9 connector pin #2 (BR wire) to a neutral (W wire). If 115VAC is not present, replace CB.

## 10) Defrost–Freezer (auxiliary code P-6 and later) and RFH1-SSB-HD Freezer

### A. Defrost Initiation

1a) **Freezer (auxiliary code P-6 and later)–LEDs 1 (DH, DrH, DctH, and CordH) and 3 (EvapFM off) are on:** DT terminates or manual defrost initiated. DH, DrH, DctH, and CordH energize. "dEF" displayed on DB. If energized, Comp, ConFM, and EvapFM de-energize.

1b) **RFH1-SSB-HD Freezer–LEDs 1 (DH), 3 (EvapFM off), and 5 (CPH and DrH (auxiliary code Q-5 and later)) are on:** DT terminates or manual defrost initiated. CPH and DrH (auxiliary code Q-5 and later) continue. DH energizes. "dEF" displayed on DB. If energized, Comp, ConFM, and EvapFM de-energize.

Note: Some models may utilize any combination of the following heaters during defrost: Duct Heater, Cord Heater, or Drain Heater. See "VII.Wiring Diagrams" for specific model details.

- a) **Checkout:** Has DT terminated? Is "dEF" displayed on DB? Check that DH energizes and Comp, ConFM, and EvapFM de-energize.
- b) **DH Diagnosis:** Check for 115VAC at CB K1 connector pin #6 (O wire) to a neutral (W wire). If 115VAC is not present, confirm that the appliance is not in the 5-minute defrost recovery period. Wait 5 minutes, then check CB K1 connector pin #6 (O wire) to a neutral (W wire) again. If 115VAC is not present, and Comp is not energized, replace CB. If 115VAC is present, confirm DH amperage. If amperage is not present, check defrost thermostat and DH continuity. If amperage is present, confirm that evaporator warms to 100°F (38°C) at DTh location. Next, check DTh status. See "III.C. Thermistor Check." When DTh reaches 100°F (38°C), DH de-energizes. If DH remains energized past 100°F (38°C), replace CB.
- c) **Comp Diagnosis:** If Comp does not de-energize, check for 115VAC at CB K1 connector pin #10 (GY wire) to a neutral (W wire). If 115VAC is present, replace CB. If 115VAC is not present, check continuity of Comp relay contacts. If closed, replace Comp relay.
- d1) **ConFM Diagnosis: Freezer (auxiliary code P-6 and later):** If ConFM does not de-energize, check for 115VAC at CB K9 connector pin #2 (BR wire) to a neutral (W wire). If 115VAC is present, replace CB.
- d2) **ConFM Diagnosis: RFH1-SSB-HD Freezer:** If ConFM does not de-energize, check for 115VAC at CB K1 connector pin #10 (GY wire) to a neutral (W wire). If 115VAC is present, replace CB. If 115VAC is not present, check continuity of Comp relay contacts. If closed, replace Comp relay.
- f) **EvapFM Diagnosis:** If EvapFM does not de-energize, check for 115VAC at CB K1 connector pin #3 (DBU wire) to a neutral (W wire). If 115VAC is present, replace CB.

## B. Defrost Termination: Defrost Recovery Step 1

- 1a) **Freezer (auxiliary code P-6 and later)–LEDs 3 (EvapFM off), 4 (Comp), and 5 (ConFM) are on:** DTh warms to 100°F (38°C) or 1-hour defrost timer terminates. DH, DrH, DctH, and CordH de-energize. 5 minutes later, Comp and ConFM energize.
- 1b) **RFH1-SSB-HD Freezer–LEDs 3 (EvapFM off), 4 (Comp and ConFM), and 5 (CPH and DrH (auxiliary code Q-5 and later)) are on:** DTh warms to 100°F (38°C) or 1-hour defrost timer terminates. DH de-energizes. 5-minutes later, Comp and ConFM energize. CPH and DrH (auxiliary code Q-5 and later) continue.

Note: Some models may utilize any combination of the following heaters during defrost. Duct Heater, Cord Heater, or Drain Heater. See "VII.Wiring Diagrams" for specific model details.

- a) **Comp Diagnosis:** Check that Comp energizes. If Comp does not energize, check for 115VAC at CB K1 connector pin #10 (GY wire) to a neutral (W wire). If 115VAC is not present, replace CB. If 115VAC is present, check for 115VAC at Comp relay black (BK wire) and red (R wire) to a neutral (W wire). If 115VAC is not present on the black (BK wire), check wiring connections. If 115VAC is present on black (BK wire) but not on the red (R wire), Comp relay contacts are open. Confirm 115VAC on Comp relay coil gray (GY wire) to a neutral (W wire). If 115VAC is present, and contacts are open, replace Comp relay. Next, if 115VAC is present on the red (R wire), check continuity of Comp overload. If overload is closed, check start capacitor, start relay, and Comp motor winding. If overload is open, let overload cool and reset. Replace overload if it does not reset. When overload closes, if Comp still does not start, check start capacitor, start relay, and Comp motor winding.
- b1) **ConFM Diagnosis: Freezer (auxiliary code P-6 and later):** If ConFM does not energize, check for 115VAC at CB K9 connector pin #2 (BR wire) to a neutral (W wire). If 115VAC is not present, replace CB. Next, check that the fan blade is not binding and that ConFM continuity is good.
- b2) **ConFM Diagnosis: RFH1-SSB-HD Freezer:** If ConFM does not energize, check for 115VAC at CB K1 connector pin #10 (GY wire) to a neutral (W wire). If 115VAC is not present, replace CB. If 115VAC is present, check for 115VAC at Comp relay black (BK wire) and red (R wire) to a neutral (W wire). If 115VAC is not present on the black (BK wire), check wiring connections. If 115VAC is present on black (BK wire) but not on the red (R wire), Comp relay contacts are open. Confirm 115VAC on Comp relay coil gray (GY wire) to a neutral (W wire). If 115VAC is present, and contacts are open, replace Comp relay. Next, check that the fan blade is not binding and that ConFM continuity is good.

### C. Defrost Termination: Defrost Recovery Step 2

- 1a) **Freezer (auxiliary code P-6 and later)–LEDs 4 (Comp) and 5 (ConFM) are on. LED 3 (EvapFM on) is off:** DTh cools to 70°F (21°C) or lower, EvapFM energizes.
- 1b) **RFH1-SSB-HD Freezer–LEDs 4 (Comp and ConFM) and 5 (CPH and DrH (auxiliary code Q-5 and later)) are on. LED 3 (EvapFM on) is off:** DTh cools to 70°F (21°C) or lower, EvapFM energizes.
  - a) **EvapFM Diagnosis:** Confirm cabinet temperature is at or below 70°F (21°C). Check CTh status. See "III.C. Thermistor Check." If EvapFM does not energize, make sure "door" is not displayed on DB. If so, check that CB dip switch #3 is in the factory default position. See, "II.E.4.c) Door Switch Type (S3 dip switch 3)." Check door switch continuity. Next, check for 115VAC at CB K1 connector pin #3 (DBU wire) to a neutral (W wire). If 115VAC is not present, replace CB. If 115VAC is present, check EvapFM blade for binding and EvapFM continuity.

### D. Defrost Termination: Defrost Completion

- 1a) **Freezer (auxiliary code P-6 and later)–LEDs 4 (Comp) and 5 (ConFM) are on. LED 3 (EvapFM on) is off:** When CTh reads 15°F (8.3°C) above setpoint or less, cabinet temperature is displayed on DB. Defrost is complete.
- 1b) **FH1-SSB-HD Freezer–LEDs 4 (Comp and ConFM) and 5 (CPH and DrH (auxiliary code Q-5 and later)) are on. LED 3 (EvapFM on) is off:** When CTh reads 15°F (8.3°C) above setpoint or less, cabinet temperature is displayed on DB. Defrost is complete.

Legend: **CB**–control board; **ConFM**–condenser fan motor; **Comp**–compressor; **CordH**–cord heater; **CPH**–condensate pan heater; **CTh**–cabinet thermistor; **DB**–display board; **DctH**–duct heater; **DH**–defrost heater; **DrH**–drain heater; **DT**–defrost thermostat; **DTh**–defrost thermistor; **EvapFM**–evaporator fan motor; **PH**–perimeter heater; **TXV**–thermostatic expansion valve

## B. Control Board Check

Before replacing a CB that does not show a visible defect and that you suspect is bad, always conduct the following check procedure. This procedure will help you verify your diagnosis. Always choose a neutral (W wire) to establish a good neutral connection when checking high voltages.

Alarm Reset: If CB is in alarm (beeping), press the "ALARM RESET" button on CB with power on. For alarm information, see "II.E.3. LED Lights and Alarm Safeties Chart."

- 1) Check S3 dip switch settings to assure that they are in the factory default position. For factory default settings, see "II.E.4.Default Dip Switch Settings."
- 2) Move the power switch to the "ON" position. If the "POWER OK" LED is on, CB control voltage (10VAC) is good. If the "POWER OK" LED is off, check CT circuit. CT output is 10VAC at 115VAC primary input. If the secondary circuit has proper voltage (10VAC) and the "POWER OK" LED is off, CB is bad and must be replaced.  
If the secondary circuit does not have proper voltage, check CT primary circuit and incoming voltage to a neutral (W wire).
- 3) The "OUTPUT TEST" button provides a relay sequence test. Move the power switch to the "ON" position. Next, press the "OUTPUT TEST" button. CB cycles through all relays in sequence. The correct LED lighting sequence is 3, 2, 1, 4, 5. Note that the order of the LEDs from the outer edge of the board is 5, 4, 1, 2, 3. Components (e.g., Comp) cycle during the test. Following the output test, the appliance resumes operation. If the LEDs do not light as described above, CB is bad and must be replaced.
- 4) Confirm Clogged Filter Thermostat: Check for 5VDC at CB K6 connector pin #2 (P wire) to K5 connector pin #2 (open). If 5VDC is not present, CB is bad and must be replaced.
- 5) Door Switch: Check for 5VDC at CB K6 connector pin #4 (LBU wire) to K5 connector pin #2 (open). If 5VDC is not present, CB is bad and must be replaced.
- 6) High-Pressure Switch: Check for 5VDC at CB K6 connector pin #6 (V wire) to K5 connector pin #2 (open). If 5VDC is not present, CB is bad and must be replaced.
- 7) Confirm proper output voltage (3.8VDC) at RED K4 connector (CTh) pin #1 to pin #2 gray (GY) wires and WHITE K3 connector (DTh) pin #1 to pin #2 orange (O) wires. If no voltage is present, CB is bad and must be replaced.
- 8) As the appliance cycles through the sequence of operation, check for 115VAC from K1 and K9 connector pins to a neutral (W wire).

Relay	LED	Component Energized	LED ON/OFF	Control Board Connector
X1	1	Defrost Heater (Freezer)	ON	K1 Pin #6
X2	2	Cabinet Light (door switch)	ON	K1 Pin #5
X3	3	Evaporator Fan Motor	OFF	K1 Pin #3
X4	4	Compressor Relay	ON	K1 Pin #10
X5	5	Condenser Fan Motor Condensate Pan Heater (RFH1)	ON	K9 Pin #2

Legend: **CB**—control board; **Comp**—compressor; **CT**—control transformer; **CTh**—cabinet thermistor; **DH**—defrost heater; **DTh**—defrost thermistor

## C. Thermistor Check

In the event the cabinet thermistor reading is out of range, the compressor operates on a fixed time basis of 5-minutes on and 5-minutes off.

In the event the defrost (evaporator) thermistor reading is out of range, defrost initiation occurs every 6 hours and terminates based on cabinet thermistor temperature.

In the event of both thermistor readings are out of range, the compressor operates on a fixed time basis of 5-minutes on and 5-minutes off and the defrost cycle initiates every 6 hours and terminates after 45 minutes.

To check thermistor resistance, follow the steps below.

- 1) Raise the front panel. Move the power switch to the "OFF" position, then unplug the appliance.
- 2) Remove the control box cover.
- 3) Remove the cabinet and defrost thermistors.
- 4) Disconnect the cabinet thermistor (gray (GY) wires) from the RED K3 connector and the defrost thermistor (orange (O) wires) from the WHITE K3 connector.
- 5) Immerse the thermistor sensor portion in a glass containing ice and water for 2 or 3 minutes.
- 6) Check the resistance between the wires at the thermistor connector. Normal reading is within 4.7 to 6.2 k $\Omega$ . If outside the normal reading, replace the thermistor.
- 7) Replace the thermistors in their correct positions.
- 8) Reconnect the red and white thermistor connectors to the control board RED K4 and WHITE K3 thermistor connectors.
- 9) Replace the control box cover in its correct positions.
- 10) Plug the appliance back in. Move the power switch to the "ON" position.
- 11) Close the front panel.

## D. Clogged Filter Thermostat and High-Pressure Switch

Confirm the air filter is clean and ConFM is energized and fan blade turns freely. Check that the condenser coil is not clogged or restricted.

Confirm that appliance location meets factory requirements:

- This appliance is not intended for outdoor use. Normal operating ambient temperature should be within 45°F to 100°F (7°C to 38°C).
- The appliance should not be located next to ovens, grills, or other high heat producing equipment.
- The appliance should not be located in a corrosive environment.
- The appliance should be a minimum of 4" (11 cm) from side walls.
- A minimum of 10" (25 cm) overhead clearance should be provided for proper ventilation.

**Diagnosis: Clogged Filter Thermostat:** This is a N/O switch. Closing temperature is 163°F±5°F (72°C±2.7°C) and opening temperature is 153°F±5°F (67°C±2.7°C). When the clogged filter thermostat closes, DB displays "CF" alternating with cabinet temperature.

CB provides 5VDC from CB K6 connector pin #2 (P wire). Confirm CB 5VDC CB supply by checking for 5VDC at CB K6 connector pin #2 (P wire) and CB K5 connector pin #2 (open). If 5VDC is not present, CB is bad and must be replaced.

**Diagnosis: High-Pressure Switch:** This may be a N/O (normally open) or N/C (normally closed) HPS. See "VII. Wiring Diagrams" for cut-out and cut-in configuration (CB automatically adjusts to N/O or N/C HPS). If HPS trips 3 times in 1-hour, E4 alarm occurs on CB. Press "RESET" on CB. See "II.E.3. LED Lights and Alarm Safeties Chart." Check that the air filter and condenser are clean. Next, check that the ConFM is operating. See "III.E.1.8. High-Pressure Switch." CB provides 5VDC from CB K6 connector pin #6 (V wire). Confirm 5VDC CB supply by checking for 5VDC at CB K6 connector pin #6 (V wire) and CB K5 connector pin #2 (open). If 5VDC is not present, CB is bad and must be replaced.

Legend: **CB**—control board; **ConFM**—condenser fan motor; **DB**—display board;  
**HPS**—high-pressure switch

<p>High-Pressure Alarm</p> <p>Compressor discharge pressure is outside normal operating range. High-pressure switch has been triggered 3 or more times in 1 hour.</p> <p>If the high-pressure switch trips 5 times in 1 hour, compressor stops and will not restart.</p>	<p>Press "RESET." If high-pressure switch resets automatically, alarm will stop and "E4" will clear when high-pressure switch closes. After 5 high-pressure switch trips, the alarm can be silenced for 1 hour by pressing the "RESET".</p> <p>For the service tech to reset this alarm, press "ALARM RESET" on the control board itself.</p>
--	---

## E. Diagnostic Chart

Before consulting the diagnostic charts, check the following:

- Check the setpoint. For factory default settings, see "II.E.1.a) Temperature Setpoint."
- Make sure the doors are not left open or opened too often and that they are sealing properly.
- Make sure product is not blocking airflow or that the cabinet is not overloaded with warm or hot product. Product should be cooled before putting it in the appliance.
- Check for correct installation and proper voltage per appliance nameplate. This appliance is not intended for outdoor use. Normal operating ambient temperature should be within 45°F to 100°F (7°C to 38°C). The appliance should not be located next to ovens, grills, or other high heat producing equipment. The appliance should be a minimum of 4" (11 cm) from side walls and a minimum of 10" (25 cm) overhead clearance should be provided for proper ventilation.
- Check the control board using the steps in "III.B. Control Board Check."

### 1. Appliance Not Cooling

Appliance Not Cooling - Possible Cause	
1. Power Supply	a) Unplugged, off, blown fuse, or tripped or defective circuit breaker.
	b) Loose connection.
	c) Not within specifications.
2. Cord and Plug	a) Loose connection.
	b) Defective.
3. Power Switch (control box)	a) "OFF" position.
	b) Bad contacts.
4. Wiring	a) Loose connection or open.
	b) Faulty.
5. Control Transformer	a) Defective.
6. Display Board	a) Not communicating with control board (ribbon cable loose).
	b) Defective.
7. Control Board See "II.E.3. LED Lights and Alarm Safeties Chart" and "III.B. Control Board Check."	a) In alarm.
	b) Dip switches not set correctly. See "II.E.4. Default Dip Switch Settings."
	c) Not communicating with display board (ribbon cable loose).
	d) Defective.
8. High-Pressure Switch (E4 alarm, 3 or more pressure trips in 1 hour, 6 beep alarm)	a) Dirty condenser.
	b) Ambient temperature too warm.
	c) Condenser fan motor not operating.
	d) Refrigerant overcharge.
	e) Refrigerant lines or components restricted.
	f) Bad contacts.
9. Clogged Filter Thermostat	a) Dirty filter, condenser, or defective thermostat.
10. Cabinet Thermistor	a) Defective.
11. Defrost Thermistor	a) Defective.
12. Evaporator Fan Motor	a) Defective.
13. Condenser Fan Motor	a) Defective.

<b>Appliance Not Cooling - Possible Cause</b>	
14. Compressor Relay	a) Bad contacts.
	b) Open coil windings.
15. Compressor Protector	a) Dirty condenser.
	b) Condenser fan not operating.
	c) Defective.
16. Start Relay	a) Defective
17. Start Capacitor	a) Defective.
18. Compressor	a) Defective.
19. Condenser	a) Dirty.
20. Evaporator See "2. Evaporator Frozen Up."	a) Dirty or frozen.
21. Refrigerant/Refrigerant Lines	a) Gas leak.
	b) Refrigerant lines restricted.
22. Backup Defrost Thermostat	a) Stuck open/defective.
23. Defrost	a) See "3. Defrost Fails to Terminate" below.

## 2. Evaporator Frozen Up

<b>Evaporator is Frozen Up - Possible Cause</b>	
1. Defrost Frequency	a) Not enough defrost occurring per day. See "II.E.1.b) Defrost Frequency."
2. Evaporator	a) Dirty.
3. Evaporator Fan Motor	a) Defective.
	b) Fan Blade Binding.
4. Control Board	a) Defective.
5. Refrigerant Charge	a) Low.
6. Thermostatic Expansion Valve	a) Defective.
7. Defrost Thermistor (Freezer Only)	a) Out of position or defective.
8. Defrost Heater (Freezer Only)	a) Defective.
9. Drain Line	a) Restricted.
10. Defrost Drain Heater (Freezer Only Auxiliary Code P-6 and Later)	a) Defective.

## 3. Defrost Fails to Terminate

<b>Defrost Fails to Terminate - Possible Cause</b>	
1. Defrost Thermistor	a) Out of position or defective. See "III.C. Thermistor Check."
2. Control Board	a) Defective.

## 4. Other

<b>Abnormal Noise - Possible Cause</b>	
1. Fan Blade (evaporator or condenser)	a) Loose.
2. Fan Motor (evaporator or condenser)	a) Defective.
3. Compressor	a) Defective.

---

## IV. Replacement of Components

### **⚠ WARNING**

- This appliance should be diagnosed and repaired only by qualified service personnel to reduce the risk of death, electric shock, serious injury, or fire.
- Move the power switch to the "OFF" position, then unplug the appliance from the electrical outlet before servicing.

## A. Service for Refrigerant Lines

### **⚠ WARNING**

- Repairs requiring the refrigeration circuit to be opened must be performed by properly trained and EPA-certified service personnel.
- Use an electronic leak detector or soap bubbles to check for leaks. Add a trace of refrigerant to the system (if using an electronic leak detector), and then raise the pressure using nitrogen gas (140 PSIG). DO NOT use R-404A as a mixture with pressurized air for leak testing.

### **NOTICE**

- Always recover the refrigerant and store it in an approved container. Do not discharge the refrigerant into the atmosphere.
- Do not leave the system open for longer than 15 minutes when replacing or servicing parts. The Polyol Ester (POE) oils used in R-404A applications can absorb moisture quickly. Therefore it is important to prevent moisture from entering the system when replacing or servicing parts.
- Always install a new drier every time the sealed refrigeration system is opened. Do not replace the drier until after all other repair or replacement has been made. Install the new drier with the arrow on the drier in the direction of the refrigerant flow.
- When brazing, protect the drier by using a wet cloth to prevent the drier from overheating. Do not allow the drier to exceed 250°F (121°C).

### 1. Refrigerant Recovery

The appliance is provided with refrigerant access valves. Using proper refrigerant practices, recover the refrigerant and store it in an approved container. Do not discharge the refrigerant into the atmosphere.

## 2. Brazing

### **⚠ WARNING**

- R-404A itself is not flammable at atmospheric pressure and temperatures up to 176°F (80°C).
- R-404A itself is not explosive or poisonous. However, when exposed to high temperatures (open flames), R-404A can be decomposed to form hydrofluoric acid and carbonyl fluoride both of which are hazardous.
- Do not use silver alloy or copper alloy containing arsenic.
- Use an electronic leak detector or soap bubbles to check for leaks. Add a trace of refrigerant to the system (if using an electronic leak detector), and then raise the pressure using nitrogen gas (140 PSIG). Do not use R-404A as a mixture with pressurized air for leak testing.

1) Braze all fittings while purging with nitrogen gas flowing at a pressure of 3 to 4 PSIG.

Note: Because the pipes in the evaporator case are specially coated to resist corrosion, it is important to make connections outside the evaporator case when possible. If it is necessary to braze inside the evaporator case, use sandpaper to remove the coating from the brazing connections before unbrazing the components.

### **NOTICE**

- Always install a new drier every time the sealed refrigeration system is opened. Do not replace the drier until after all other repair or replacement has been made. Install the new drier with the arrow on the drier in the direction of the refrigerant flow.
- When brazing, protect the drier by using a wet cloth to prevent the drier from overheating. Do not allow the drier to exceed 250°F (121°C).

2) Use an electronic leak detector or soap bubbles to check for leaks. Add a trace of refrigerant to the system (if using an electronic leak detector), and then raise the pressure using nitrogen gas (140 PSIG). Do not use R-404A as a mixture with pressurized air for leak testing.

## 3. Evacuation and Recharge (R-404A)

1) Attach a vacuum pump to the system. Be sure the charging hoses are connected to both high and low-side access valves.

### **IMPORTANT**

The vacuum level and vacuum pump may be the same as those for current refrigerants. However, the rubber hose and gauge manifold to be used for evacuation and refrigerant charge should be exclusively for POE oils.

2) Turn on the vacuum pump. Open the gauge manifold valves. Never allow the oil in the vacuum pump to flow backwards.

- 3) Allow the vacuum pump to pull down to a 29.9" Hg vacuum. Evacuating period depends on pump capacity.
- 4) Close the low-side valve and high-side valve on the gauge manifold.
- 5) Disconnect the gauge manifold hose from the vacuum pump and attach it to a refrigerant service cylinder. Remember to loosen the connection and purge the air from the hose. For the required refrigerant charge, see the nameplate. Hoshizaki recommends only virgin refrigerant or reclaimed refrigerant which meets ARI Standard 700 (latest edition) be used.
- 6) A liquid charge is required when charging an R-404A system (to prevent fractionation). Place the service cylinder on the scales; if the service cylinder is not equipped with a dip tube, invert the service cylinder, then place it on the scales. Open the high-side valve on the gauge manifold.
- 7) Allow the system to charge with liquid until the proper charge weight is met.
- 8) If necessary, add any remaining charge to the system through the low-side. **NOTICE! To prevent compressor damage, use a throttling valve or liquid dispensing device to add the remaining liquid charge through the low-side refrigerant access valve with the appliance running.**
- 9) Close the high and low-side gauge manifold valves, then disconnect the gauge manifold hoses.
- 10) Cap the access valves to prevent a possible leak.

## B. Important Notes for Component Replacement

<b>NOTICE</b>
When replacing a component listed below, see the notes to help ensure proper operation.

Component	Notes
Compressor	Install a new start capacitor, run capacitor, and start relay.
Thermostatic Expansion Valve	<ul style="list-style-type: none"> <li>• Attach the thermostatic expansion valve bulb to the suction line in the same location as the previous bulb.</li> <li>• The bulb should be between the 10 and 2 o'clock positions on the tube.</li> <li>• Secure the bulb with the clamp and holder, then insulate it.</li> </ul>
Fan Motor	Install a new capacitor (if applicable).
Thermistor	<ul style="list-style-type: none"> <li>• Attach the new thermistor in the same location as the previous thermistor.</li> <li>• Be very careful to prevent damage to the leads.</li> </ul>
High-Pressure Switch	• Control Board adapts to an open or closed high-pressure switch by recognizing and accepting the high-pressure switch condition at startup.

## C. Removal and Replacement of Evaporator Fan Shroud Assembly

### 1. Note for RH1-SSB(-HD), RH1-SSB-GD, and Refrigerator Side of RFH2-SSB(-HD)

For RH1-SSB(-HD) aux. code M5\_\_\_\_B and earlier, RH1-SSB-GD aux. code L0 and earlier, and refrigerator side of RFH2-SSB(-HD) aux. code M5 and earlier, there was a non-interchangeable part change. If your appliance falls into this time frame and you need to replace parts in the evaporator fan shroud assembly, review the scenarios below and follow the appropriate solution.

- a. Appliance's evaporator shroud has only two holes or has four holes but only the lower two holes are threaded.

Solution: Order [HS-3541](#) that contains a motor (Shinko), brackets, blade, and all fasteners required for mounting to the shroud using the existing threaded holes. For details, see the appliance's parts list.

- b. Appliance's evaporator shroud has four threaded holes and a Jakel motor.

Solution: Order a new motor (Shinko), brackets, fan blade, and the appropriate fasteners listed in the appliance's parts list. Attach the brackets to the upper two holes on the shroud.

### 2. Note for FH1-SSB(-HD) and Freezer Side of RFH2-SSB(-HD) and RFH3-SSB(-HD)

For FH1-SSB(-HD) and freezer side of RFH2-SSB(-HD) and RFH3-SSB(-HD) aux. code M5 and earlier, there was a non-interchangeable part change. If your appliance falls into this time frame and you need to replace parts in the evaporator fan shroud assembly, order [HS-3545](#) and replace the entire assembly.

## D. Removal and Replacement of Heat Shield on FH2-SSB(-HD)

The heat shield was added to the evaporator assembly at auxiliary code M6. To replace the shield, follow the instructions below.

- 1) Remove the original heat shield by lifting the evaporator up and sliding the heat shield out.
- 2) Install the new heat shield in the rotocast drain pan.
- 3) Slide the clips onto the end plate on the evaporator. Install the two Support Clip (C) clips onto the hairpin end of the evaporator as shown in the illustration.
- 4) Install Support Clip (A) and Support Clip (B) onto the return bend end (same side as inlet and outlet tubes) as shown in the illustration.

Note: All clips are shown in the illustration in the correct orientation for installation. Slide the parts onto the evaporator brackets using the tabs on the support clips.

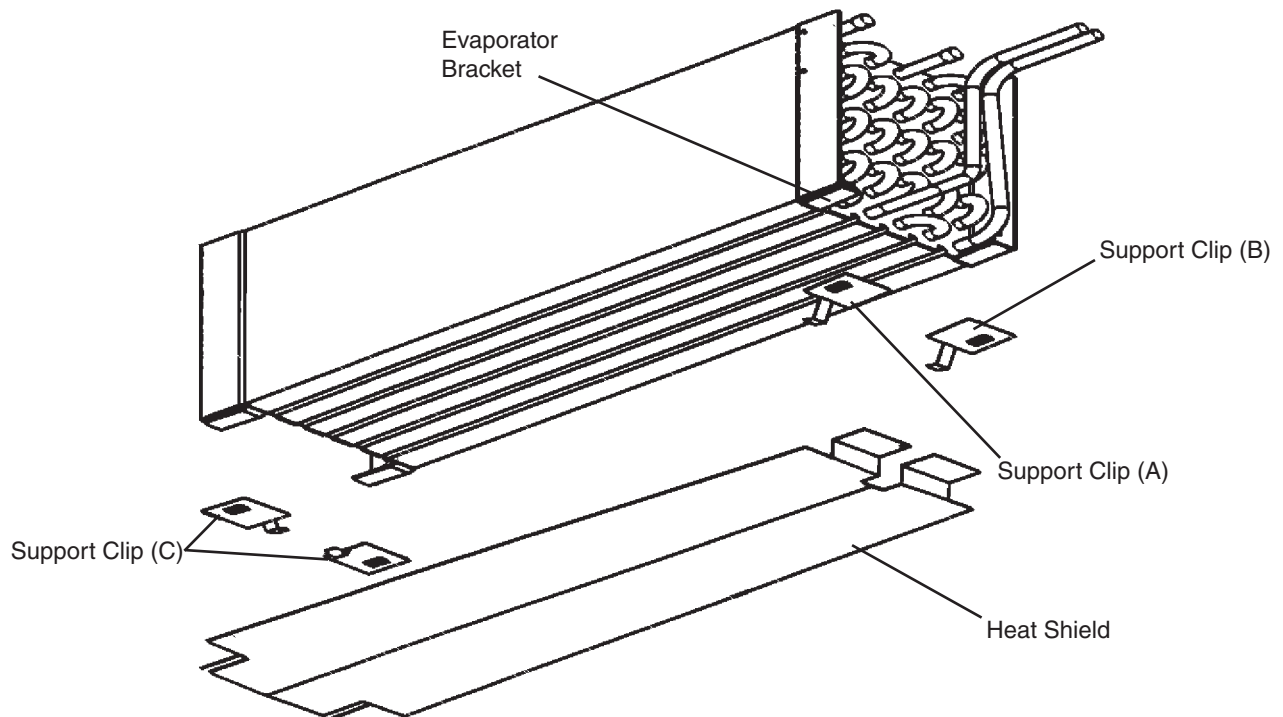

## E. Removal and Replacement of Door Closure Spring

### ⚠ WARNING

Wear eye protection and use caution when removing the tension screw (step 4).

- 1) Raise the front panel. Then, move the power switch to the "OFF" position and unplug the appliance.
- 2) Remove the wire cover.
- 3) Remove the bushing cover from the top of the spring guide pin.
- 4) Insert a small drift pin or long leg of an allen wrench into one of the threaded tension screw holes in the spring guide pin. Turn the spring guide pin to access the tension screw. Securely hold the spring guide pin in this position while removing the tension screw. Carefully rotate (walk) the spring guide pin to release spring tension.
- 5) Use a 1/2" socket wrench to remove the top pivot pin and hinge washer from the top hinge bracket.
- 6) Firmly grasp the door and pull it forward at the top. Then raise the door, disengaging it from the bottom pivot pin.
- 7) Remove the spring guide pin and spring from the spring cartridge.
- 8) Replace the spring with one of the same color. Be certain that the spring ends are engaged in both the spring cartridge and the top of the spring guide pin.
- 9) Reverse procedure to reassemble door(s) to cabinet.  
Note: Tighten spring guide pin one complete rotation to set proper spring tension.
- 10) Replace the wire cover in its correct position.
- 11) Plug the appliance back in. Move the power switch to the "ON" position.
- 12) Close the front panel.

Side	Color	Part Number
Left	Blue	4A3312-02
Right	Black	4A3312-01

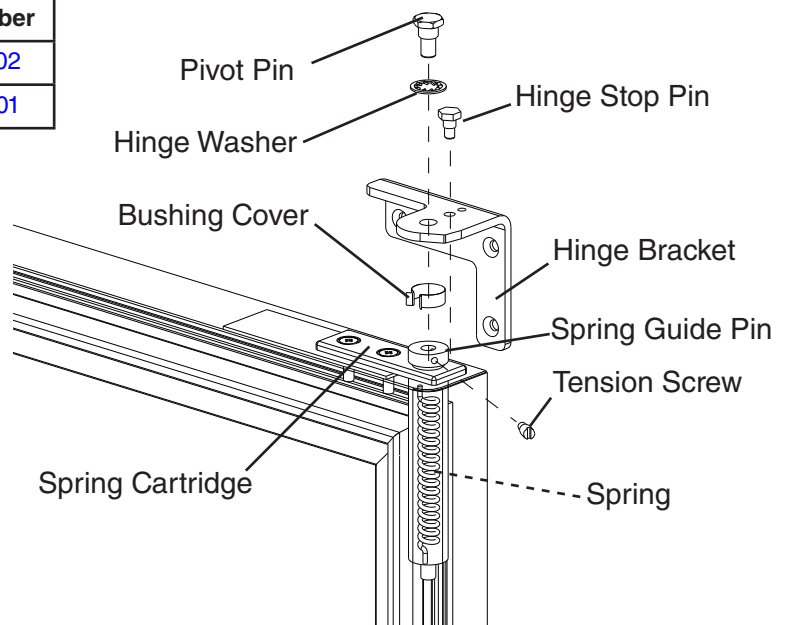
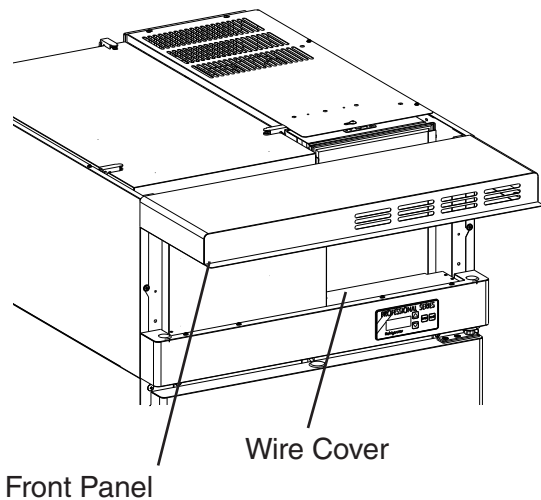

## F. Door Re-Hinging (except glass doors)

The door on any appliance is reversible as shown below. The instructions for re-hinging are provided in the kits listed below.

Convert	Door Type	Kit Number
Right to Left	Full	<a href="#">HS-3527</a>
Left to Right	Full	<a href="#">HS-3528</a>
Right to Left	Half	<a href="#">HS-3529</a>
Left to Right	Half	<a href="#">HS-3530</a>

---

## V. Maintenance

### A. Cleaning Instructions

#### **⚠ WARNING**

- Before cleaning the appliance, move the power switch to the "OFF" position and unplug the appliance to prevent electric shock by unexpected entrance of water into the appliance or injury by moving parts.
- Before cleaning the appliance, move all foods into another clean refrigerator or freezer.
- Do not splash water directly onto the appliance. This might cause short circuit, electric shock, corrosion, or failure.
- Before using a sanitizer such as inert soap and sodium hypochlorite (chlorine bleach), thoroughly read the manufacturer's instructions on its proper usage.

#### **IMPORTANT**

- To prevent damage to the plastic surfaces, do not use the following: thinner, benzine, alcohol, petroleum, soap powder, polishing powder, alkaline cleaner, acid, scouring pad and especially those strong cleaners for use on a ventilating fan or a cooking range. Also, to prevent corrosion, do not use sodium hypochlorite (chlorine bleach) on the stainless steel surfaces.
- Use a clean cloth for cleaning.

#### **1. Exterior**

Wipe the exterior occasionally with a clean, soft cloth. Use a damp cloth containing a neutral cleaner to wipe off oil or dirt buildup.

#### **2. Cabinet Interior**

Spills should be wiped up promptly to avoid unpleasant odors. The cabinet interior should be cleaned periodically with a mild soap or detergent and warm water.

#### **3. Door Gaskets**

Door gaskets should be cleaned regularly with mild soap and warm water to remove dirt and grease.

#### **4. Shelves**

Remove and clean regularly.

#### **5. Glass Door**

Wipe occasionally with a clean, soft cloth. Use a damp cloth containing a neutral cleaner to wipe off oil or dirt build up.

## B. Maintenance

### 1. Condenser

Check the condenser once a year and use a brush or vacuum cleaner to clean the condenser as required.

### 2. Power Supply Connection

If a plug or power cord is damaged, replace it. Be sure to connect the ground wire.

## C. Preparing the Appliance for Periods of Non-Use

### **WARNING**

- When preparing the appliance for long storage, prevent the doors from closing to reduce the risk of children getting trapped.
- To reduce the risk of electric shock, do not touch the plug or power switch with damp hands.
- When shutting down the appliance for more than one week, move the power switch to the "OFF" position and unplug the appliance.
- Do not plug in/unplug the appliance to start/stop operation. Make sure the power switch is in the "OFF" position before plugging in or unplugging the appliance to reduce the risk of electric shock.

- 1) Before shutting down the appliance, move the stored food into another refrigerator or freezer.
- 2) Move the power switch to the "OFF" position.
- 3) Unplug the appliance.

### ***IMPORTANT***

When preparing the appliance for long storage, clean the cabinet interior, door gaskets, and shelves. See "V.A. Cleaning Instructions" for details.

---

## VI. Disposal

<b>⚠ WARNING</b>
------------------

When preparing the appliance for disposal, remove the door to reduce the risk of children getting trapped. Leave the shelves in place so that children may not easily climb inside.
---

This appliance contains refrigerant and must be disposed of in accordance with applicable national, state, and local codes and regulations. Refrigerant must be recovered by properly certified service personnel.

# VII. Wiring Diagrams

## A1. RH1-SSB(-HD) (auxiliary code L-5 and earlier)

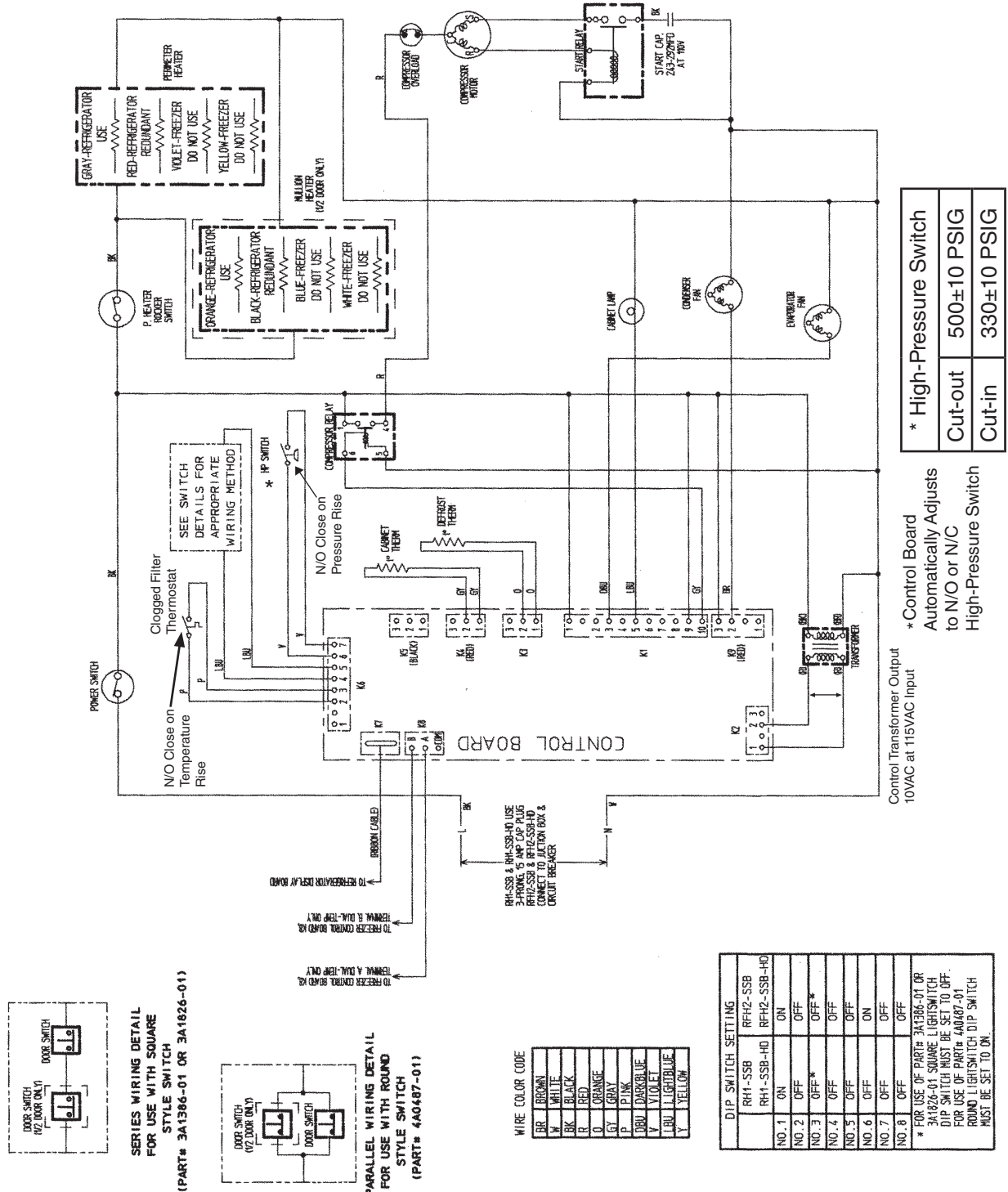

**NOTICE**

Before diagnosing and/or servicing the unit, confirm that you have the proper wiring diagram by checking against the diagram located on the evaporator case cover.

## A2. RH1-SSB(-HD)(-CF) (auxiliary code M-5 and later)

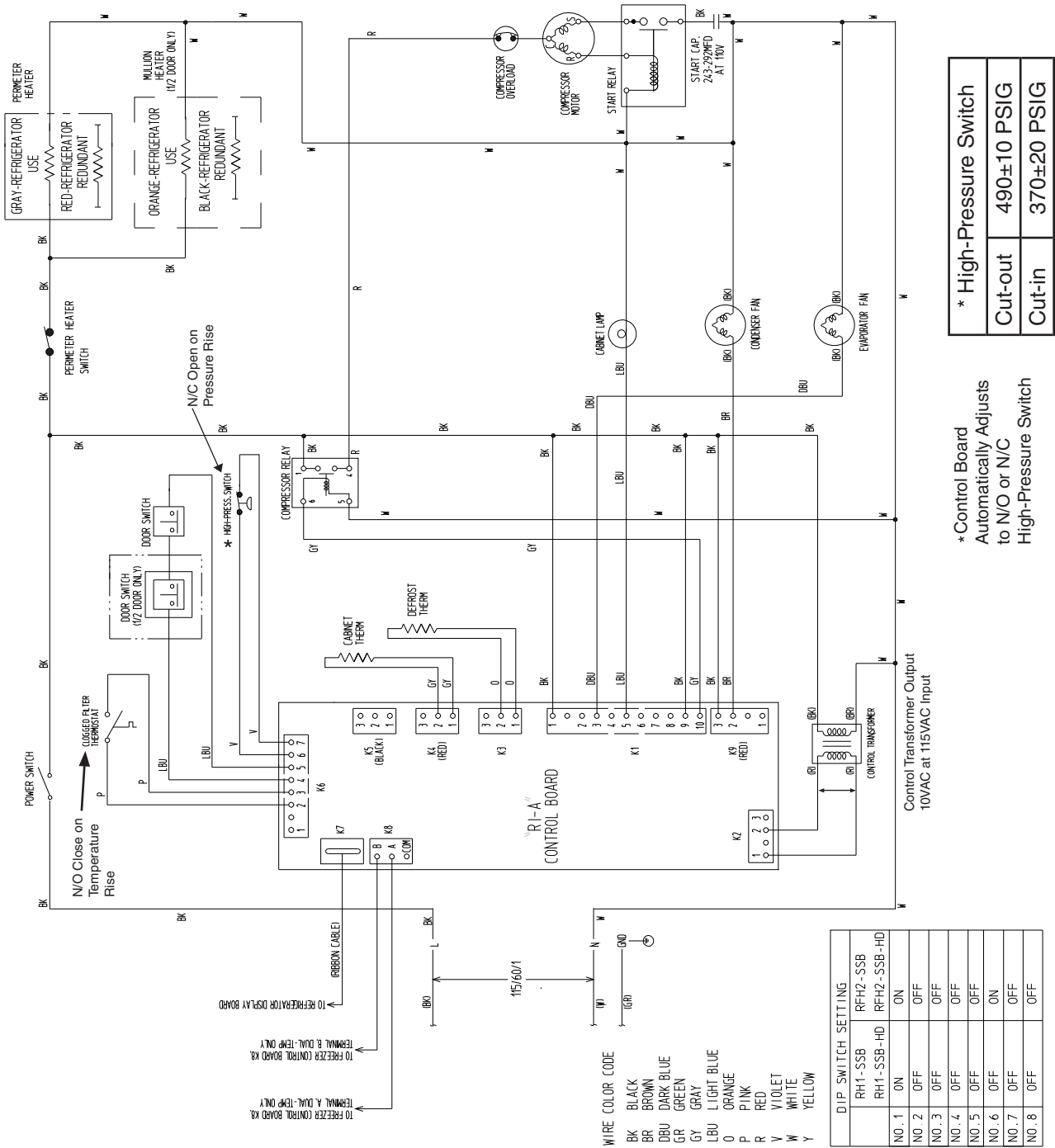

### NOTICE

Before diagnosing and/or servicing the unit, confirm that you have the proper wiring diagram by checking against the diagram located on the evaporator case cover.

# B1. RH2-SSB(-HD) (auxiliary code L-5 and earlier)

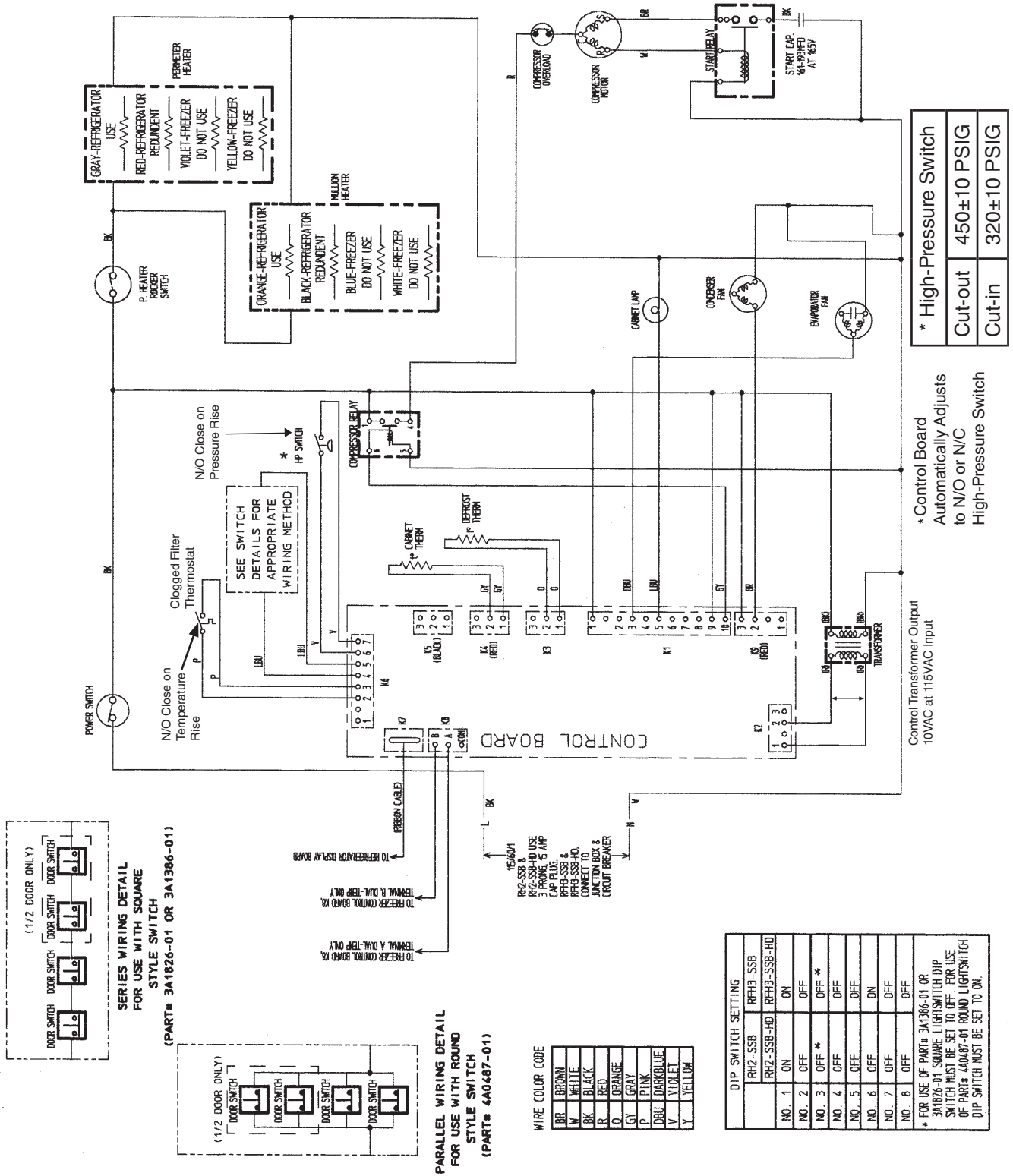

* High-Pressure Switch
Cut-out 450±10 PSIG
Cut-in 320±10 PSIG

\* Control Board Automatically Adjusts to N/O or N/C High-Pressure Switch

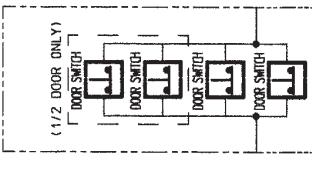
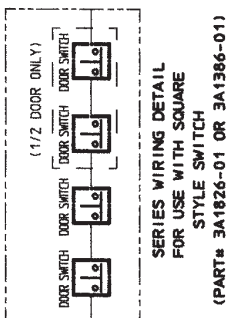

## B2. RH2-SSB(-HD) (auxiliary code M-5 and later)

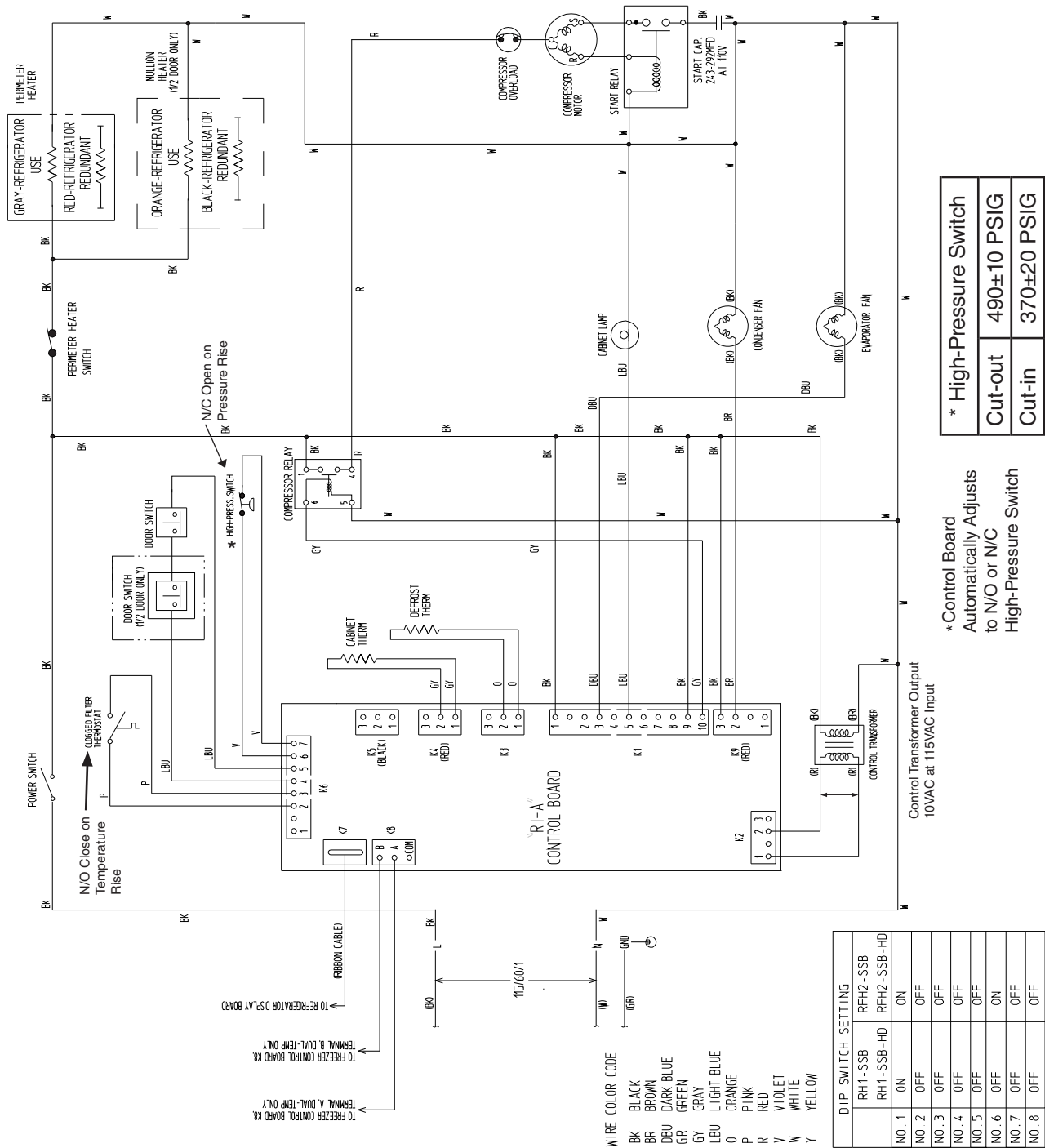

### NOTICE

Before diagnosing and/or servicing the unit, confirm that you have the proper wiring diagram by checking against the diagram located on the evaporator case cover.

# C1. RH3-SSB(-HD) (auxiliary code L-5 and earlier)

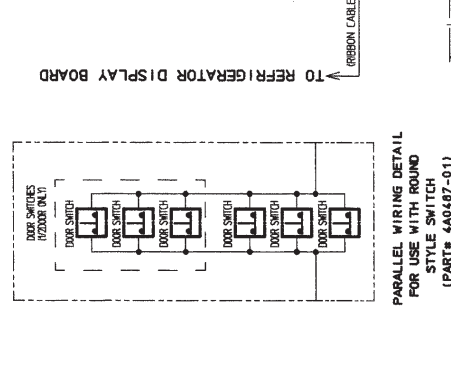
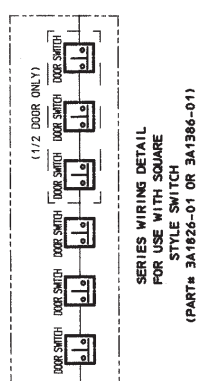
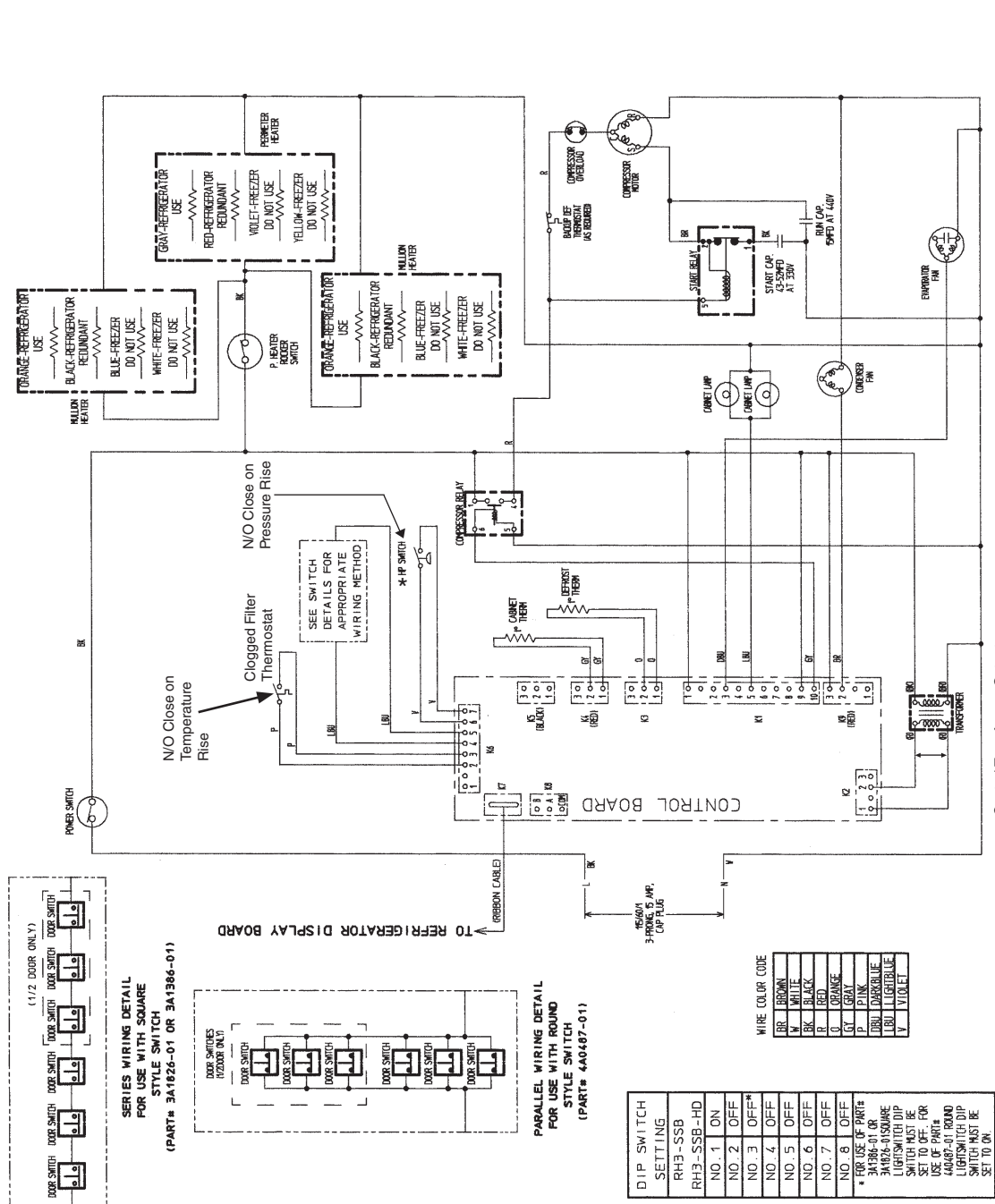

DIP SWITCH SETTING	WIRE COLOR CODE
RH3-SSB	BR BROWN
RH3-SSB-HD	W WHITE
NO. 1 ON	BK BLACK
NO. 2 OFF	R RED
NO. 3 OFF*	O ORANGE
NO. 4 OFF	GY GRAY
NO. 5 OFF	P PINK
NO. 6 OFF	DBL DARKBLUE
NO. 7 OFF	LBL LIGHTBLUE
NO. 8 OFF	V VIOLET

\* FOR USE OF PART# 3A1926-01 SQUARE LIGHT SWITCH DIP SWITCH MUST BE SET TO OFF. FOR USE OF PART# 4A0487-01 ROUND LIGHT SWITCH DIP SWITCH MUST BE SET TO ON.

* High-Pressure Switch		
Aux code H0, J0	Aux code J1 to L5	
Cut-out	450±10 PSIG	500±10 PSIG
Cut-in	320±10 PSIG	330±10 PSIG

\* Control Board Automatically Adjusts to N/O or N/C High-Pressure Switch

**NOTICE**

Before diagnosing and/or servicing the unit, confirm that you have the proper wiring diagram by checking against the diagram located on the evaporator case cover.



# D1. RH1-SSB-GD (auxiliary code N-6 and earlier)

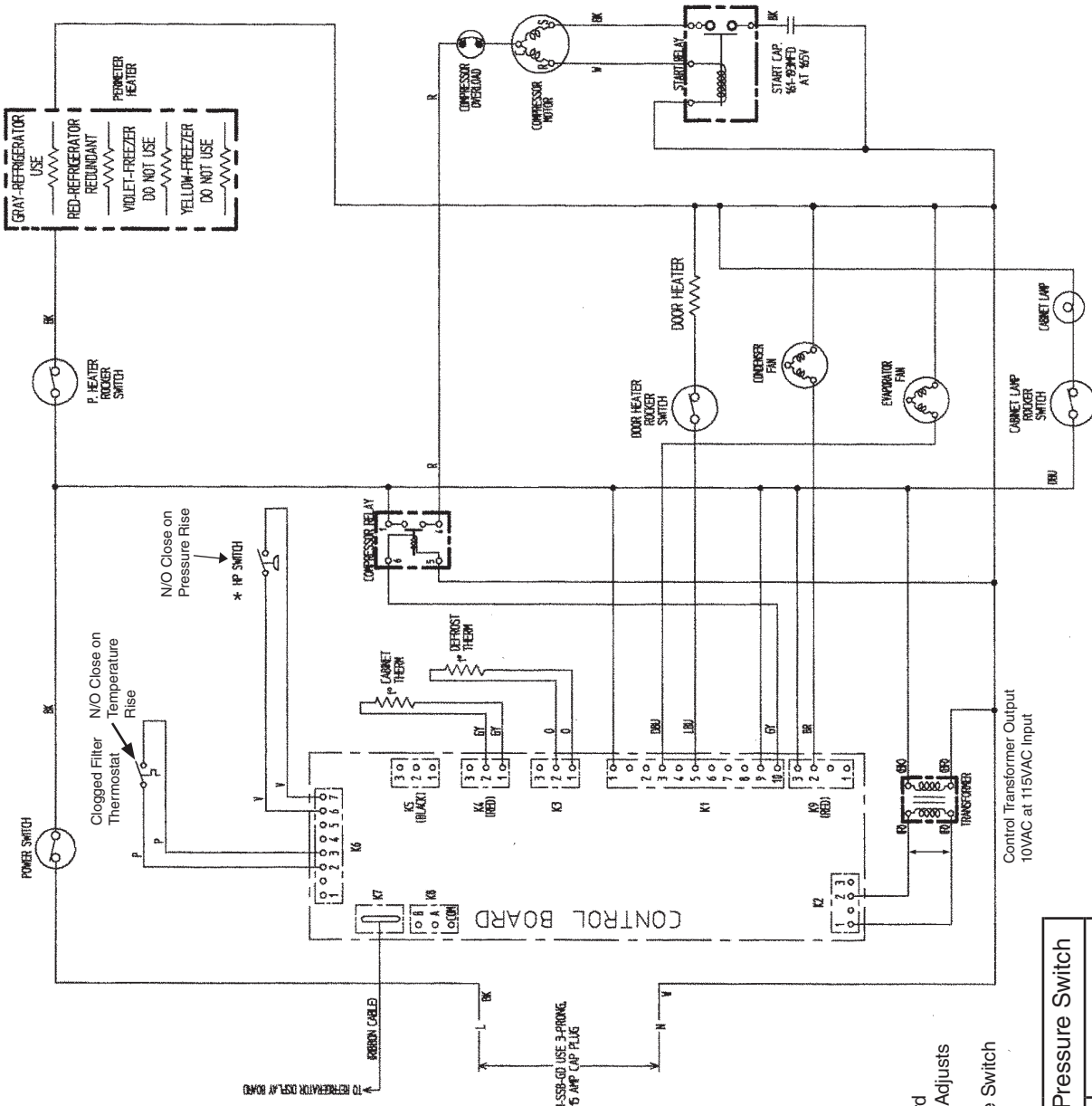

WIRE COLOR CODE

BR	BROWN
W	WHITE
BK	BLACK
R	RED
O	ORANGE
GY	GRAY
P	PINK
DBU	DARKBLUE
V	VIOLET
LB	LIGHTBLUE
Y	YELLOW

DIP SWITCH SETTING

RH1-SSB-GD	
NO. 1	ON
NO. 2	ON
NO. 3	OFF
NO. 4	OFF
NO. 5	OFF
NO. 6	OFF
NO. 7	OFF
NO. 8	OFF

\* Control Board Automatically Adjusts to N/O or N/C High-Pressure Switch

* High-Pressure Switch	
Cut-out	450±10 PSIG
Cut-in	320±10 PSIG

**NOTICE**

Before diagnosing and/or servicing the unit, confirm that you have the proper wiring diagram by checking against the diagram located on the evaporator case cover.

## D2. RH1-SSB-GD (auxiliary code P-5 and later)

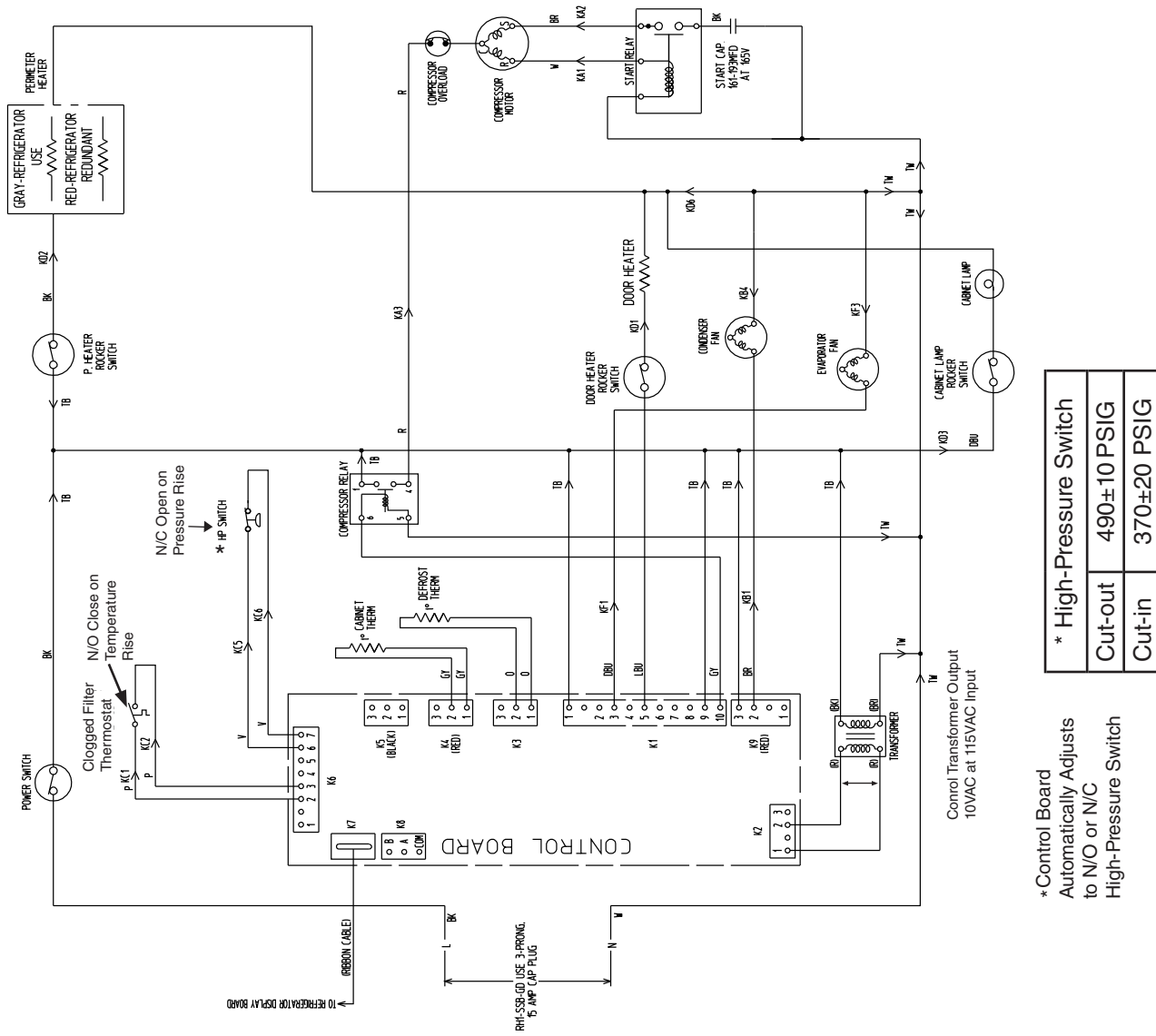

WIRE COLOR CODE

BR	BROWN
W	WHITE
BK	BLACK
R	RED
O	ORANGE
GY	GRAY
P	PINK
DBU	DARKBLUE
LBV	VIOLET
LBV	LIGHTBLUE
Y	YELLOW

DIP SWITCH SETTING

RH1-SSB-GD	
NO. 1	ON
NO. 2	ON
NO. 3	OFF
NO. 4	OFF
NO. 5	OFF
NO. 6	OFF
NO. 7	OFF
NO. 8	OFF

\* High-Pressure Switch

Cut-out	490±10 PSIG
Cut-in	370±20 PSIG

\* Control Board Automatically Adjusts to N/O or N/C High-Pressure Switch

**NOTICE**

Before diagnosing and/or servicing the unit, confirm that you have the proper wiring diagram by checking against the diagram located on the evaporator case cover.

# E1. RH2-SSB-GD (auxiliary code N-6 and earlier)

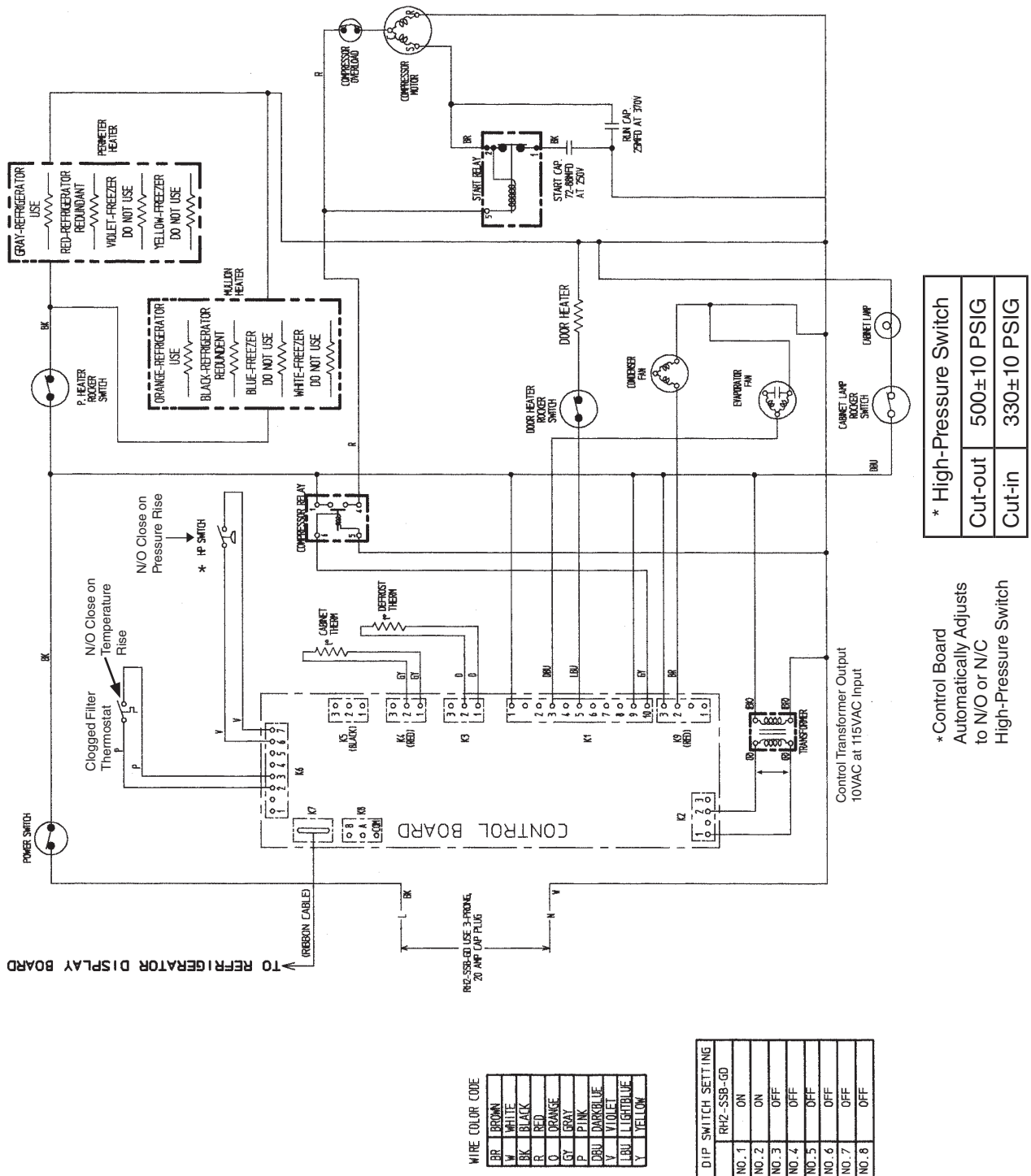

**NOTICE**

Before diagnosing and/or servicing the unit, confirm that you have the proper wiring diagram by checking against the diagram located on the evaporator case cover.

## E2. RH2-SSB-GD (auxiliary code P-5 and later)

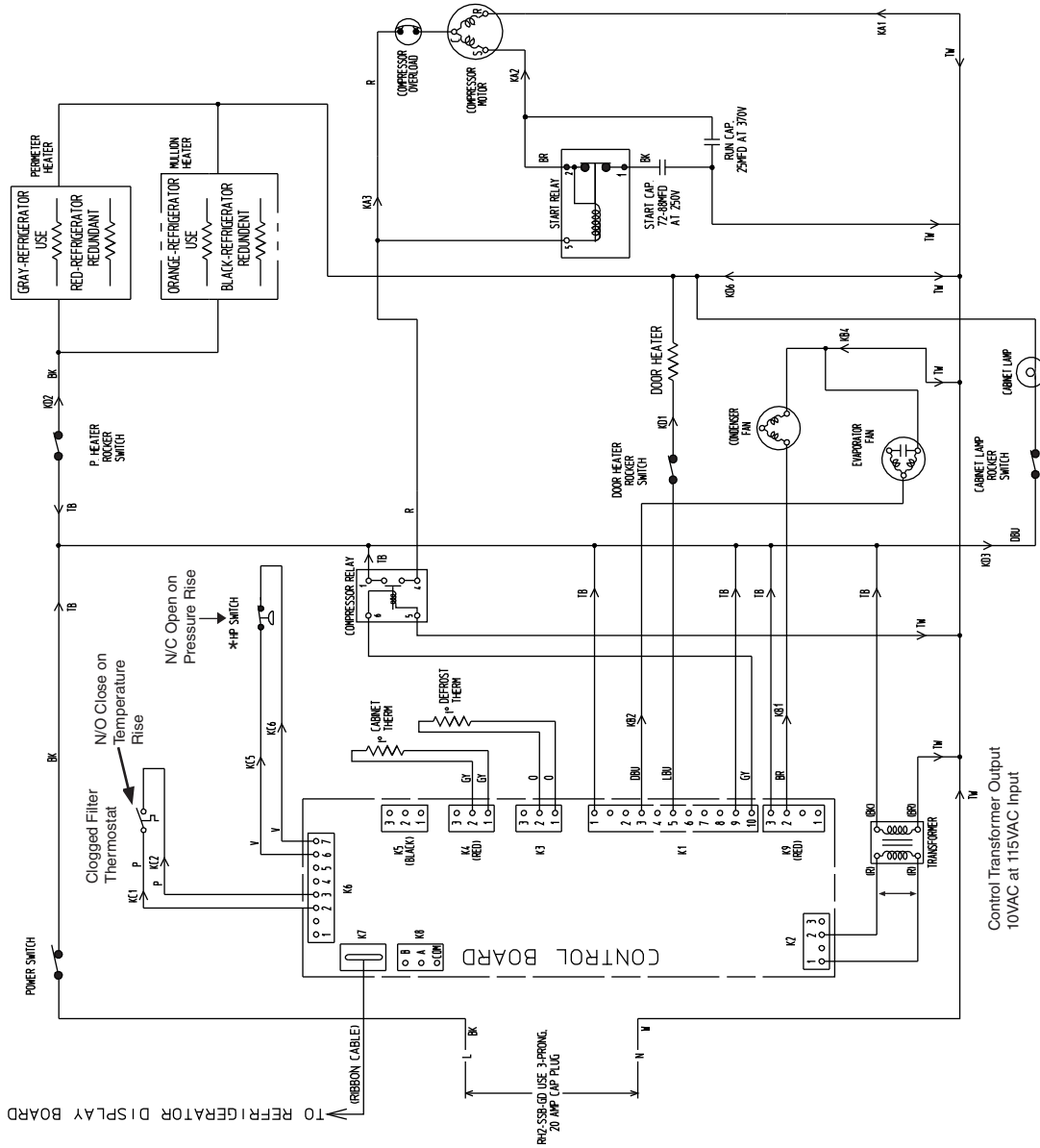

### NOTICE

Before diagnosing and/or servicing the unit, confirm that you have the proper wiring diagram by checking against the diagram located on the evaporator case cover.



## F2. RH3-SSB-FG(-HG) (auxiliary code T-5 to V-5)

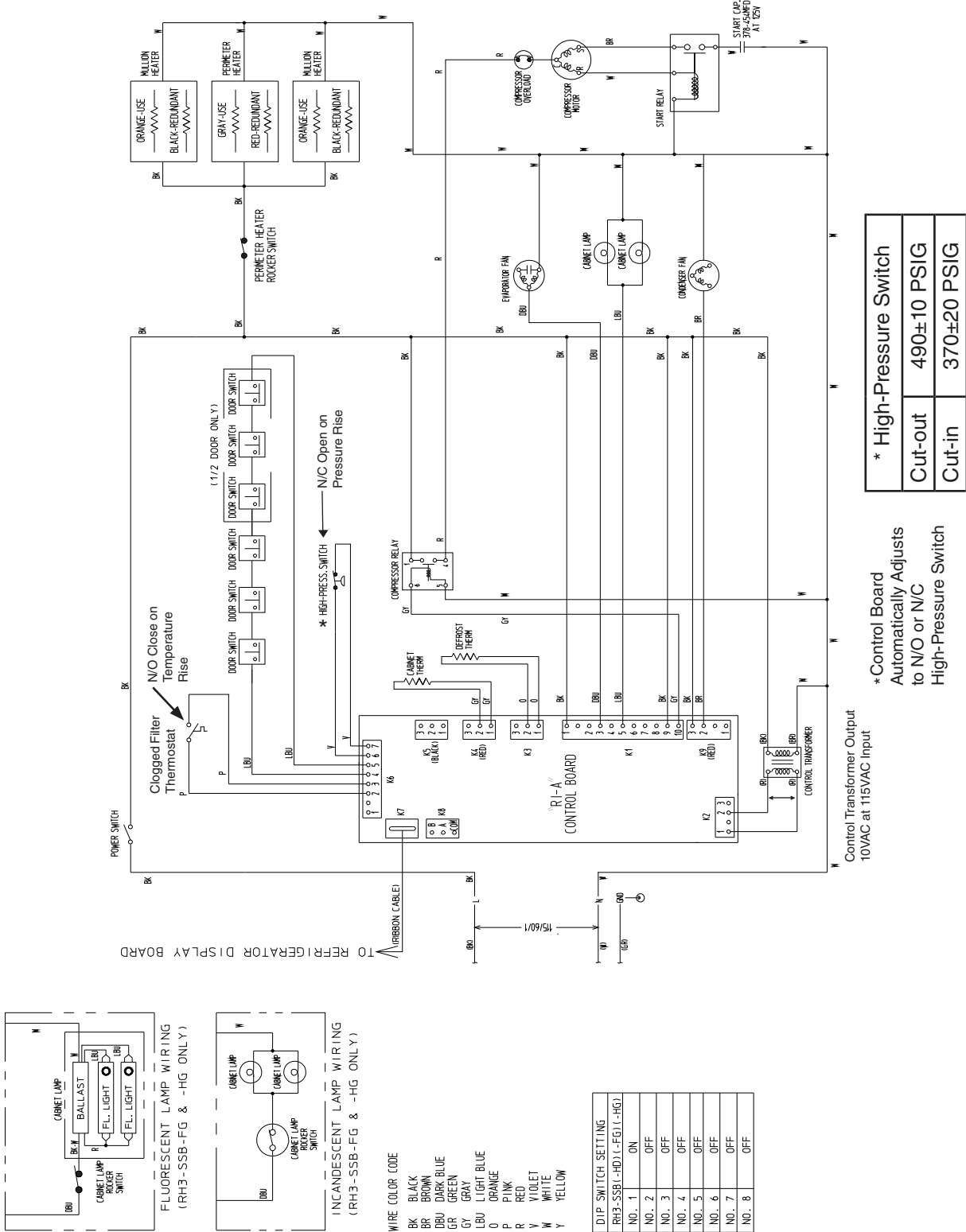

### NOTICE

Before diagnosing and/or servicing the unit, confirm that you have the proper wiring diagram by checking against the diagram located on the evaporator case cover.

# F3. RH3-SSB-FG(-HG) (auxiliary code A-5 and later)

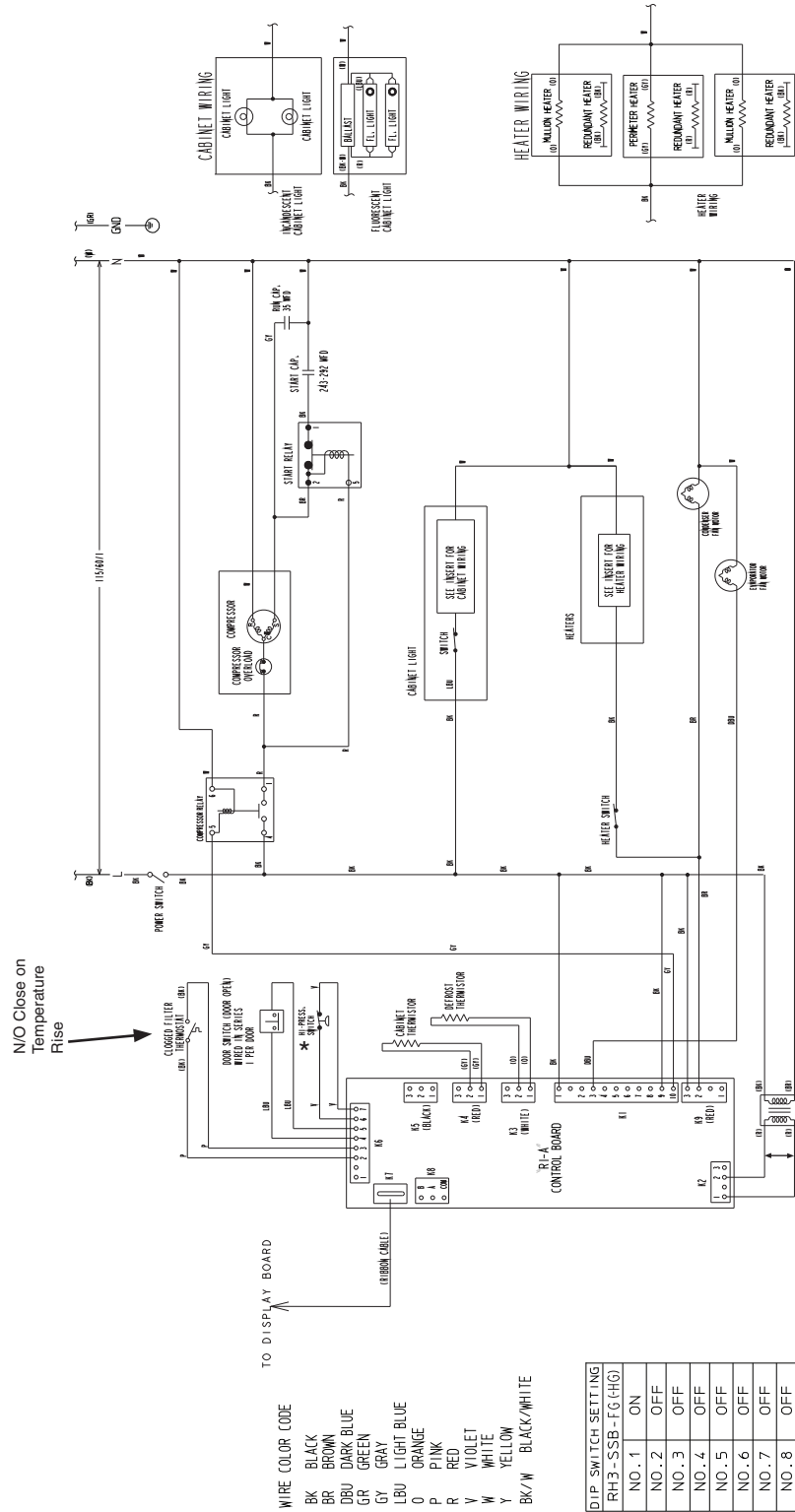

* High-Pressure Switch	
Cut-out	490±10 PSIG
Cut-in	370±20 PSIG

\*Control Board Automatically Adjusts to N/O or N/C High-Pressure Switch

Control Transformer Output 10VAC at 115VAC Input

**NOTICE**

Before diagnosing and/or servicing the unit, confirm that you have the proper wiring diagram by checking against the diagram located on the evaporator case cover.

# G1. FH1-SSB(-HD) (auxiliary code P-5 and earlier)

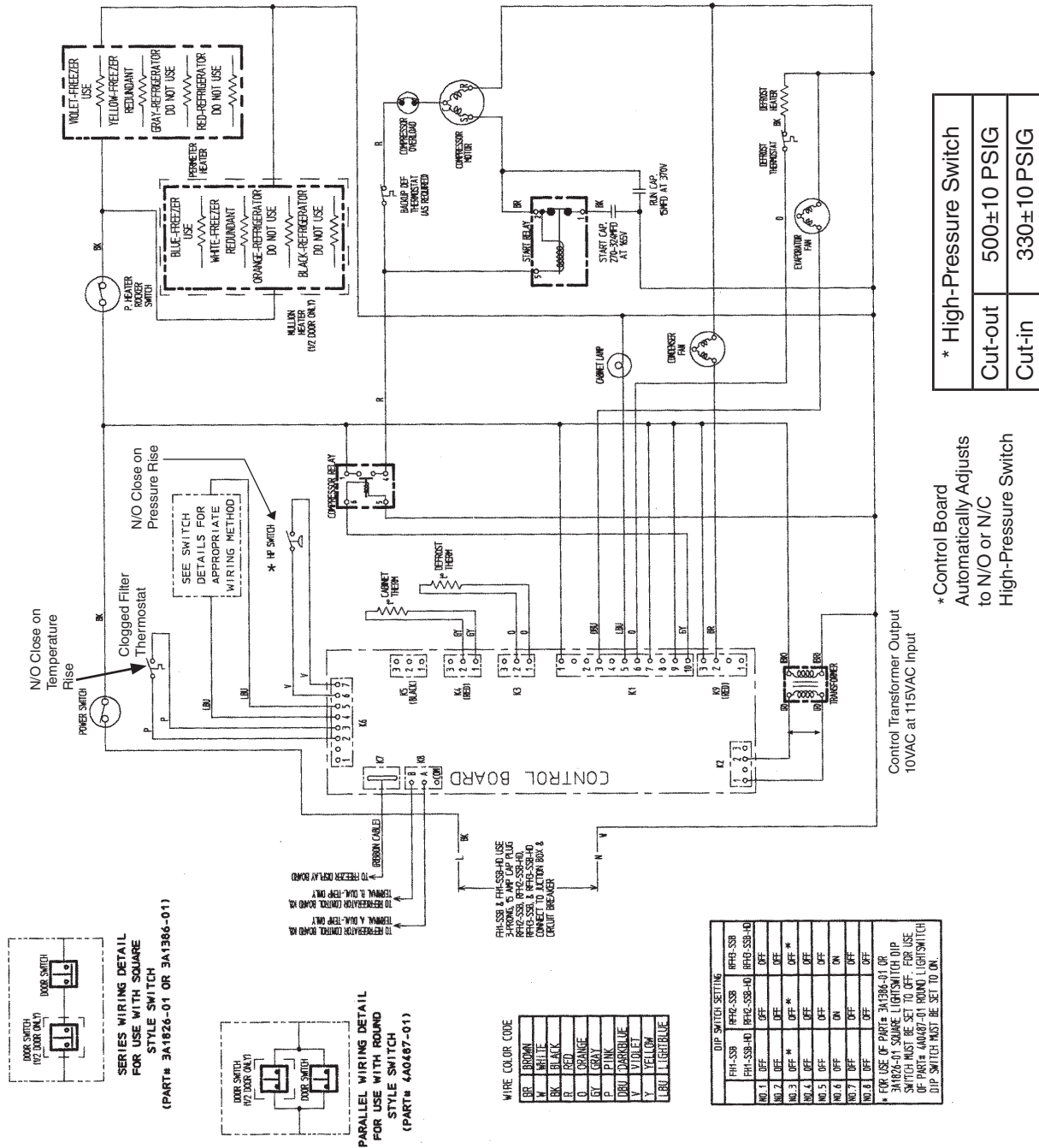

## NOTICE

Before diagnosing and/or servicing the unit, confirm that you have the proper wiring diagram by checking against the diagram located on the evaporator case cover.

# G2. FH1-SSB(-HD) (auxiliary code P-6 to S-5)

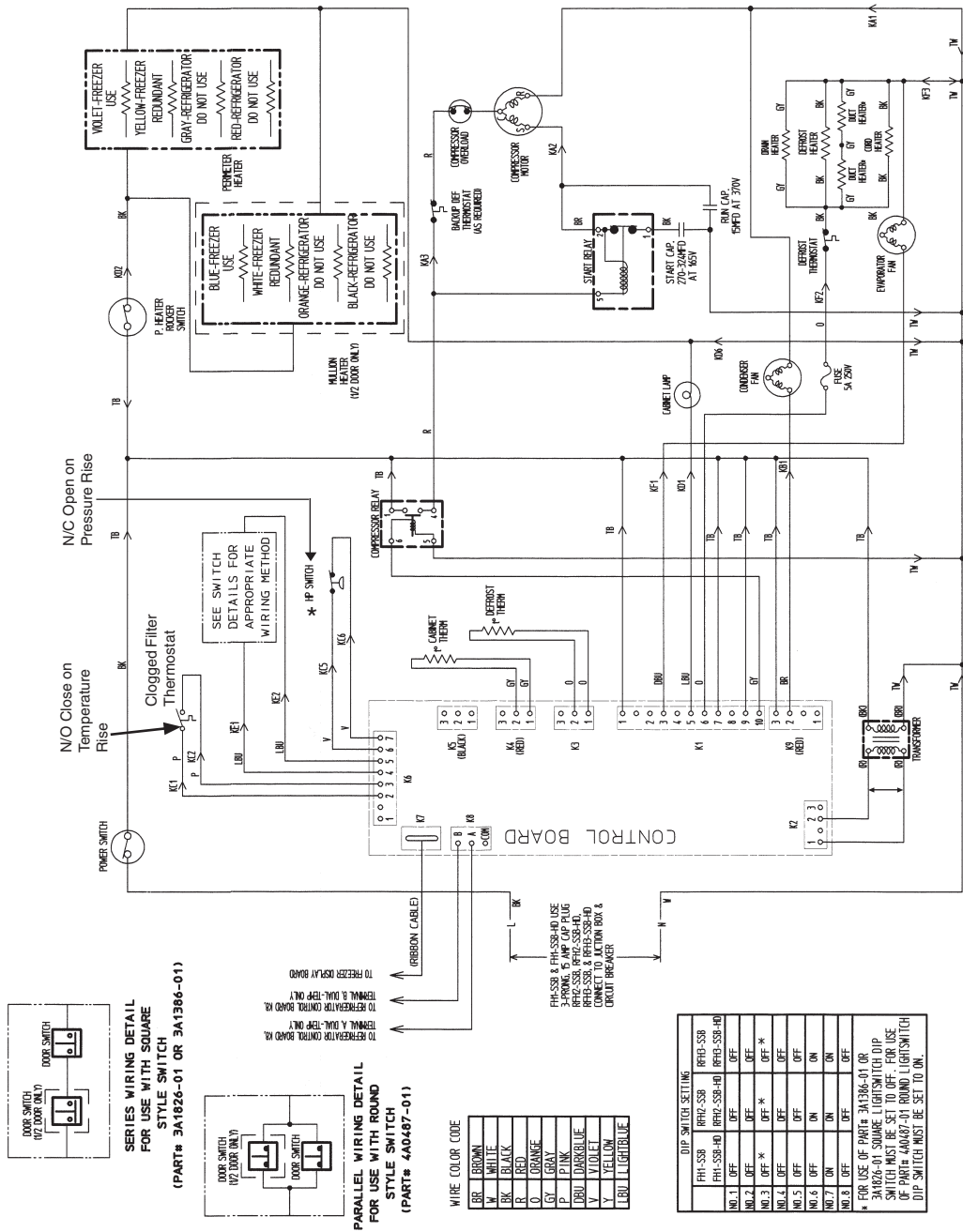

* High-Pressure Switch	
Cut-out	490±10 PSIG
Cut-in	370±20 PSIG

\* Control Board Automatically Adjusts to N/O or N/C High-Pressure Switch

Control Transformer Output 10VAC at 115VAC Input

**NOTICE**

Before diagnosing and/or servicing the unit, confirm that you have the proper wiring diagram by checking against the diagram located on the evaporator case cover.

# G3. FH1-SSB(-HD) (auxiliary code S-6 and later)

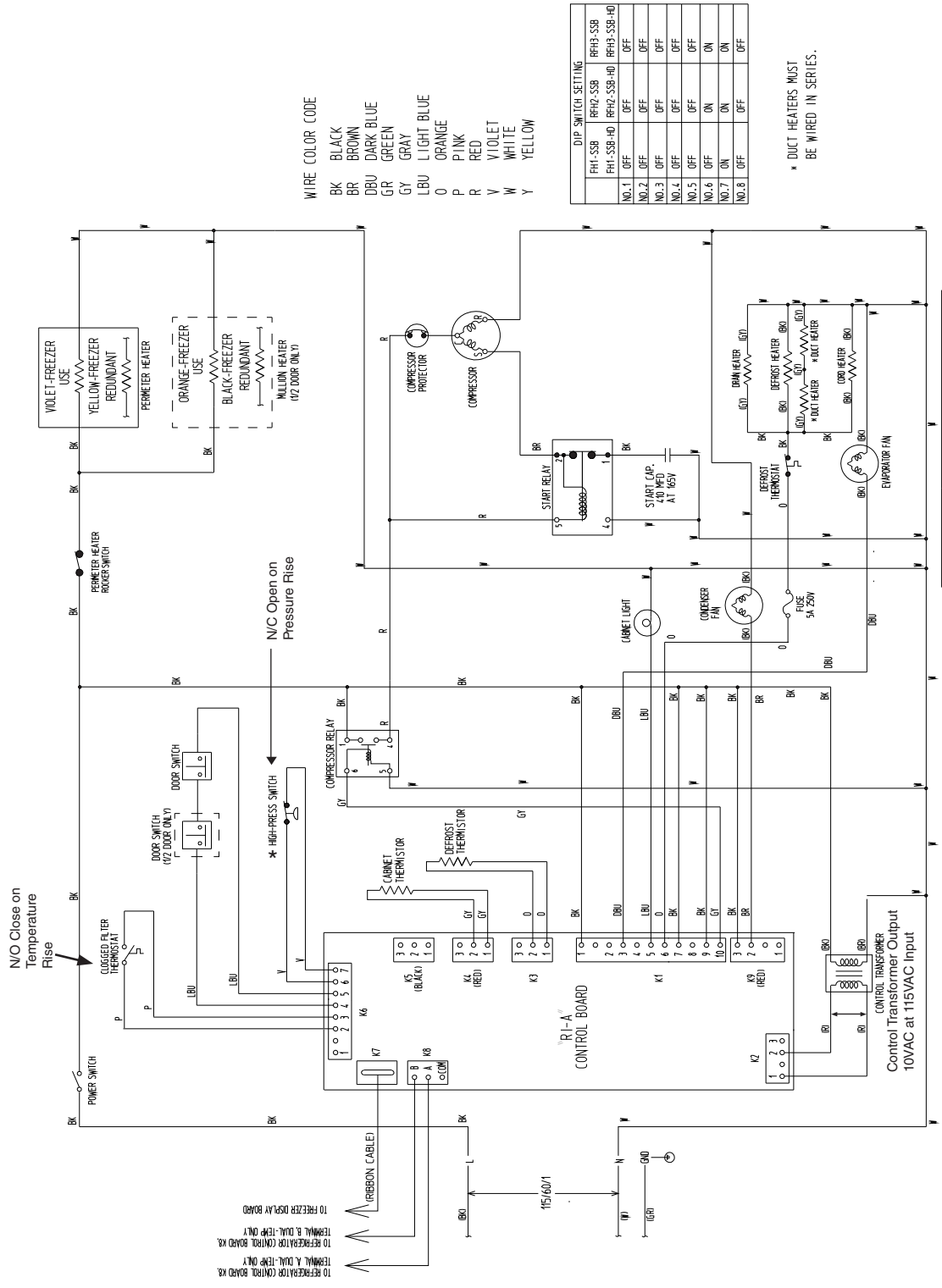

**WIRE COLOR CODE**  
 BK BLACK  
 BR BROWN  
 DBU DARK BLUE  
 GR GREEN  
 GY GRAY  
 LBU LIGHT BLUE  
 O ORANGE  
 P PINK  
 R RED  
 V VIOLET  
 W WHITE  
 Y YELLOW

DIP SWITCH SETTING		RH13-SSB	RH13-SSB
FH1-SSB	RH12-SSB	RH12-SSB-HD	RH13-SSB-HD
NO.1	OFF	OFF	OFF
NO.2	OFF	OFF	OFF
NO.3	OFF	OFF	OFF
NO.4	OFF	OFF	OFF
NO.5	OFF	OFF	OFF
NO.6	OFF	ON	ON
NO.7	ON	ON	ON
NO.8	OFF	OFF	OFF

\* DUCT HEATERS MUST BE WIRED IN SERIES.

* High-Pressure Switch	
Cut-out	490±10 PSIG
Cut-in	370±20 PSIG

\*Control Board Automatically Adjusts to N/O or N/C High-Pressure Switch

**NOTICE**  
 Before diagnosing and/or servicing the unit, confirm that you have the proper wiring diagram by checking against the diagram located on the evaporator case cover.

# H1. FH2-SSB(-HD) (auxiliary code P-5 and earlier)

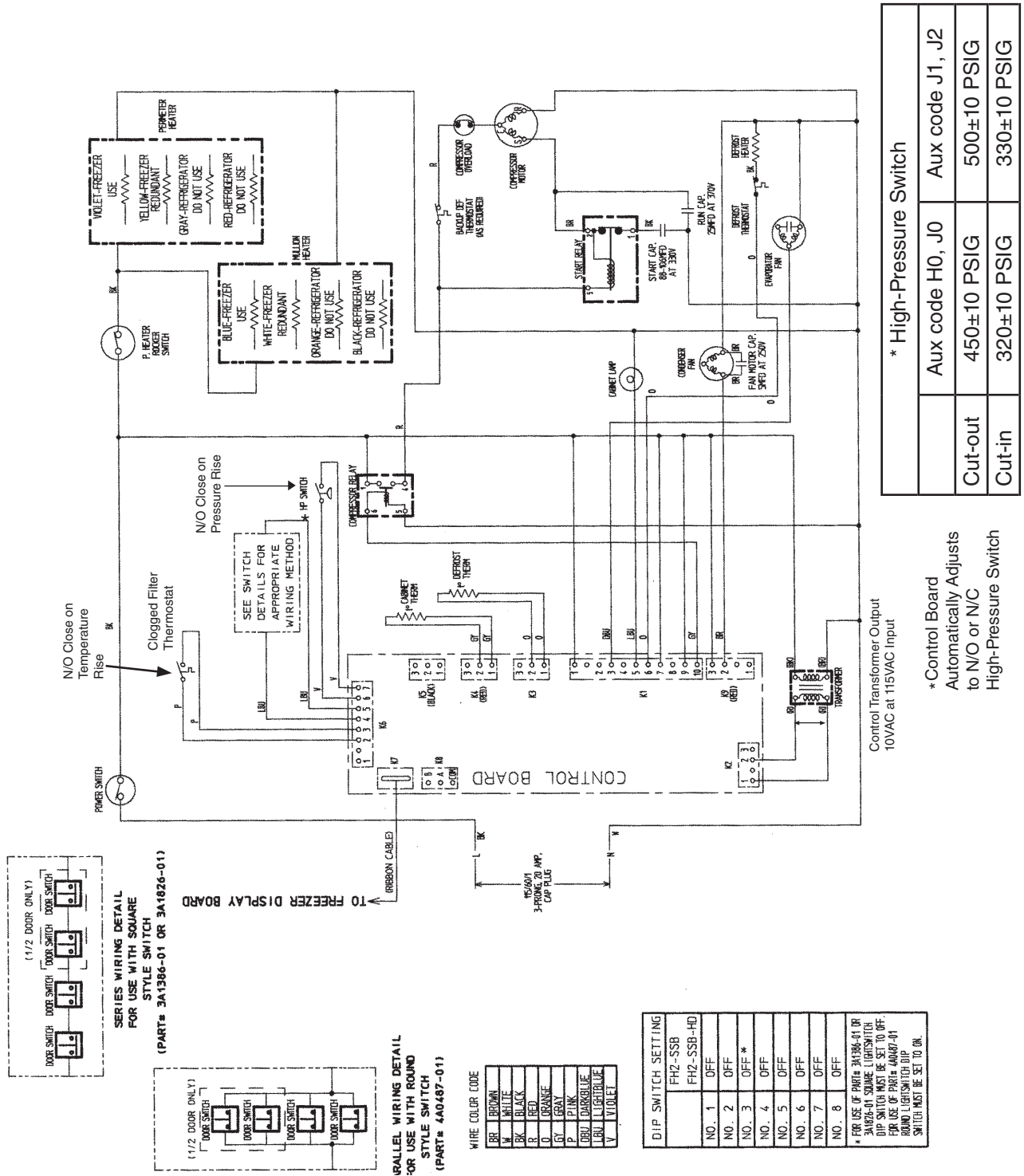

**NOTICE**

Before diagnosing and/or servicing the unit, confirm that you have the proper wiring diagram by checking against the diagram located on the evaporator case cover.

## H2. FH2-SSB(-HD)(-HDCU) (auxiliary code P-6 and later)

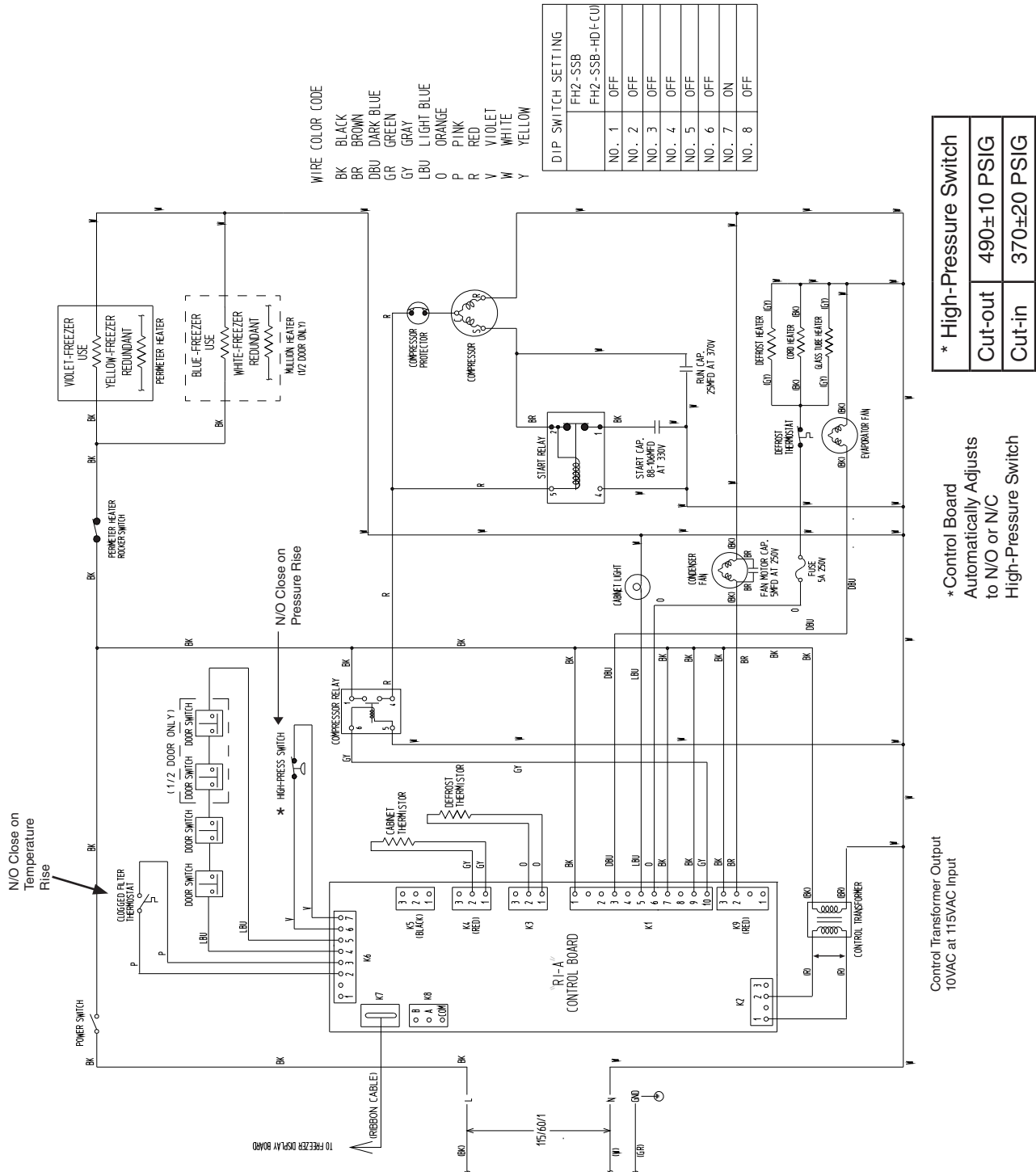

### NOTICE

Before diagnosing and/or servicing the unit, confirm that you have the proper wiring diagram by checking against the diagram located on the evaporator case cover.

# I. RFH1-SSB-HD

## 1. Refrigerator

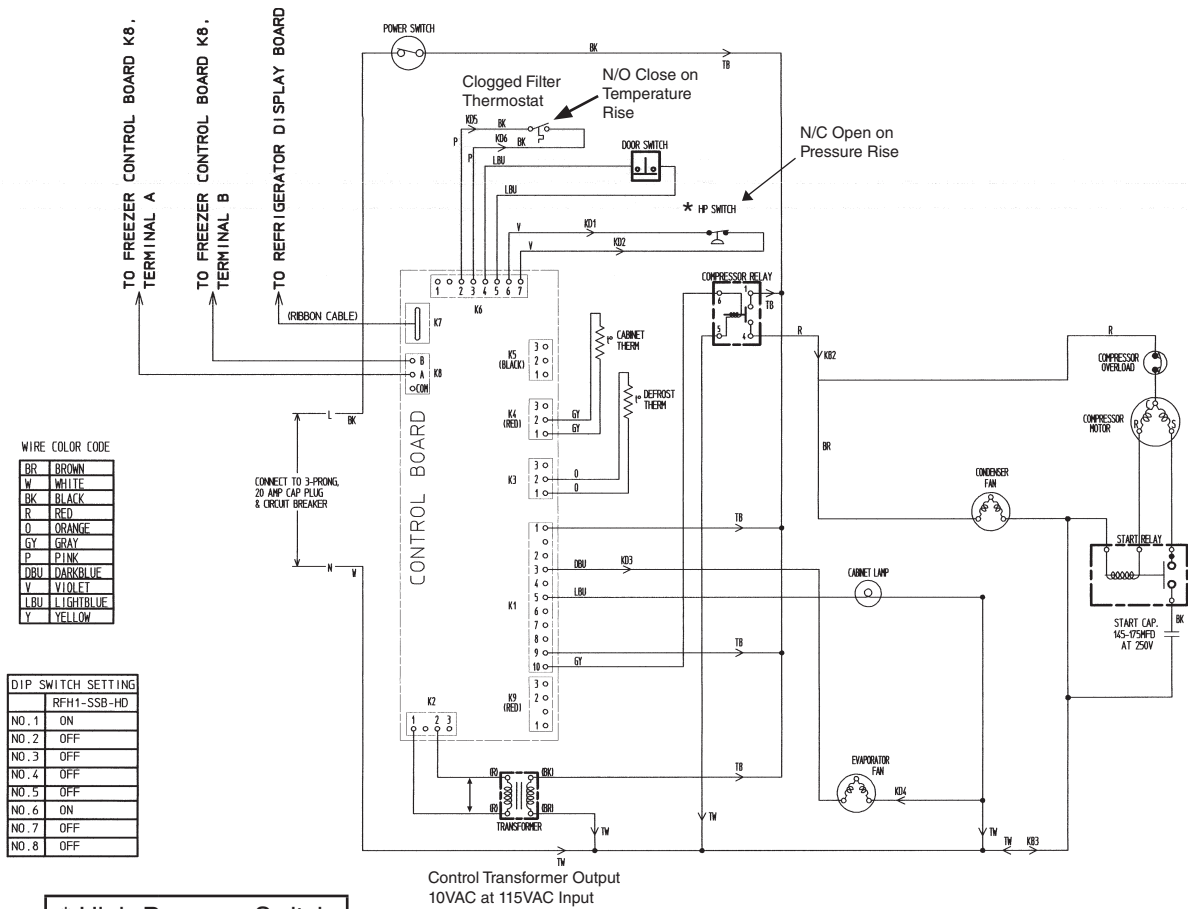

WIRE COLOR CODE

BR	BROWN
W	WHITE
BK	BLACK
R	RED
O	ORANGE
GY	GRAY
P	PINK
DBL	DARKBLUE
V	VIOLET
LBLU	LIGHTBLUE
Y	YELLOW

DIP SWITCH SETTING	RFH1-SSB-HD
NO. 1	ON
NO. 2	OFF
NO. 3	OFF
NO. 4	OFF
NO. 5	OFF
NO. 6	ON
NO. 7	OFF
NO. 8	OFF

* High-Pressure Switch	
Cut-out	490± <sup>10</sup> PSIG
Cut-in	370± <sup>20</sup> PSIG

\*Control Board Automatically Adjusts to N/O or N/C High-Pressure Switch

### RFH1-SSB-HD Main Wiring Power Cord Connections

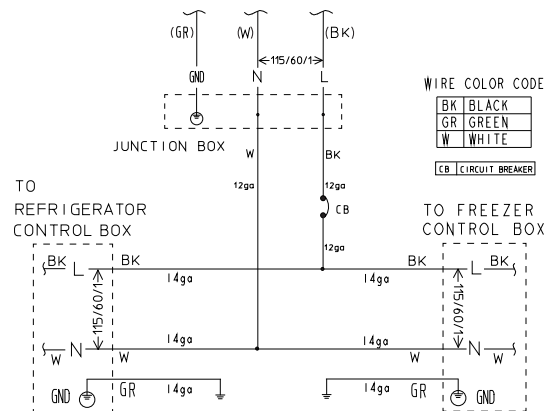

### NOTICE

Before diagnosing and/or servicing the unit, confirm that you have the proper wiring diagram by checking against the diagram located on the evaporator case cover.

# I. RFH1-SSB-HD

## 2a. Freezer (auxiliary code P-5 and earlier)

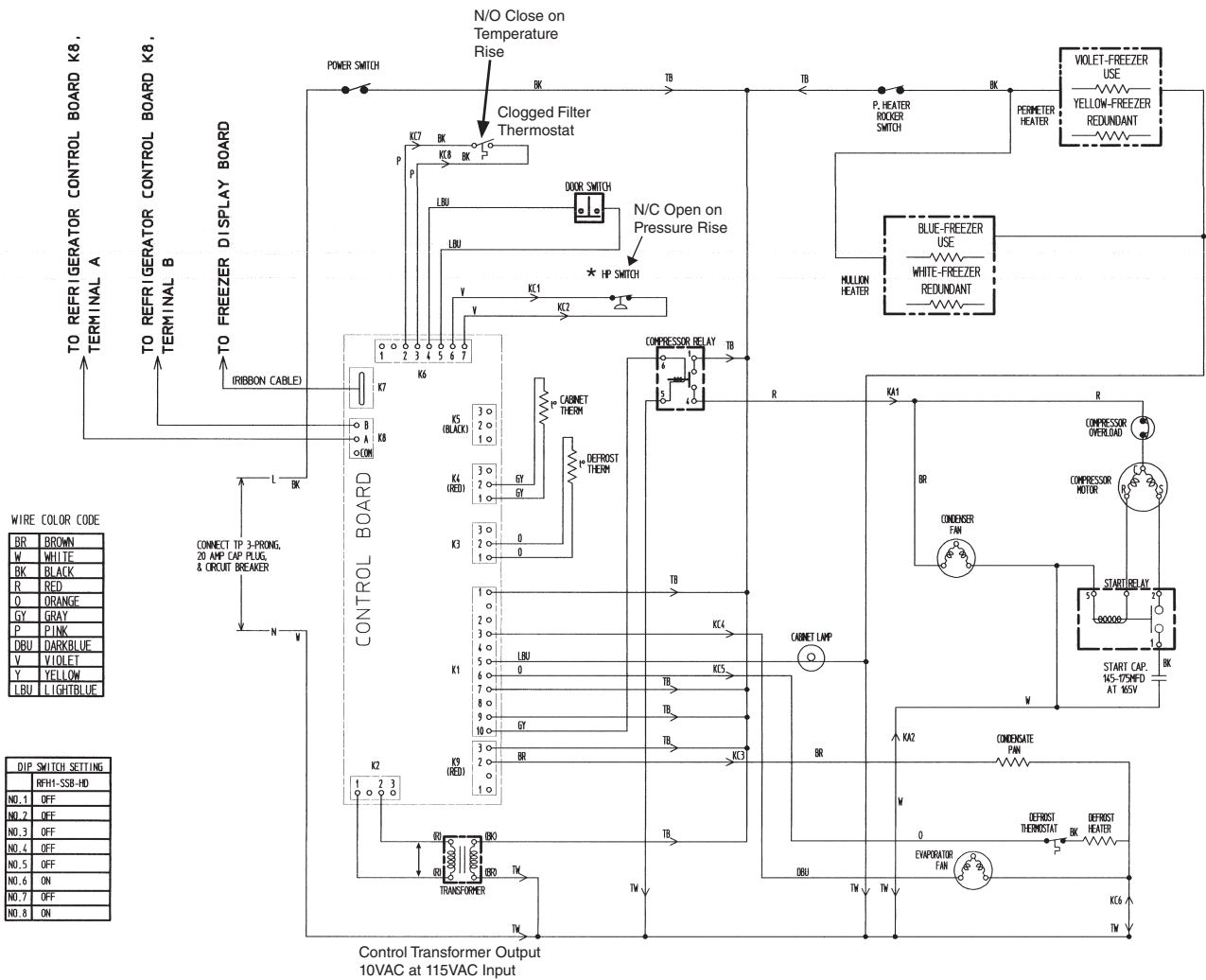

WIRE COLOR CODE

BR	BROWN
W	WHITE
BK	BLACK
R	RED
O	ORANGE
GY	GRAY
P	PINK
DBU	DARKBLUE
V	VIOLET
Y	YELLOW
LBU	LIGHTBLUE

DIP SWITCH SETTING

RFH1-SSB-HD	
NO. 1	OFF
NO. 2	OFF
NO. 3	OFF
NO. 4	OFF
NO. 5	OFF
NO. 6	ON
NO. 7	OFF
NO. 8	ON

\* Control Board Automatically Adjusts to N/O or N/C High-Pressure Switch

* High-Pressure Switch	
Cut-out	490±10 PSIG
Cut-in	370±20 PSIG

**NOTICE**

Before diagnosing and/or servicing the unit, confirm that you have the proper wiring diagram by checking against the diagram located on the evaporator case cover.

# I. RFH1-SSB-HD

## 2b. Freezer (auxiliary code Q-5 and later)

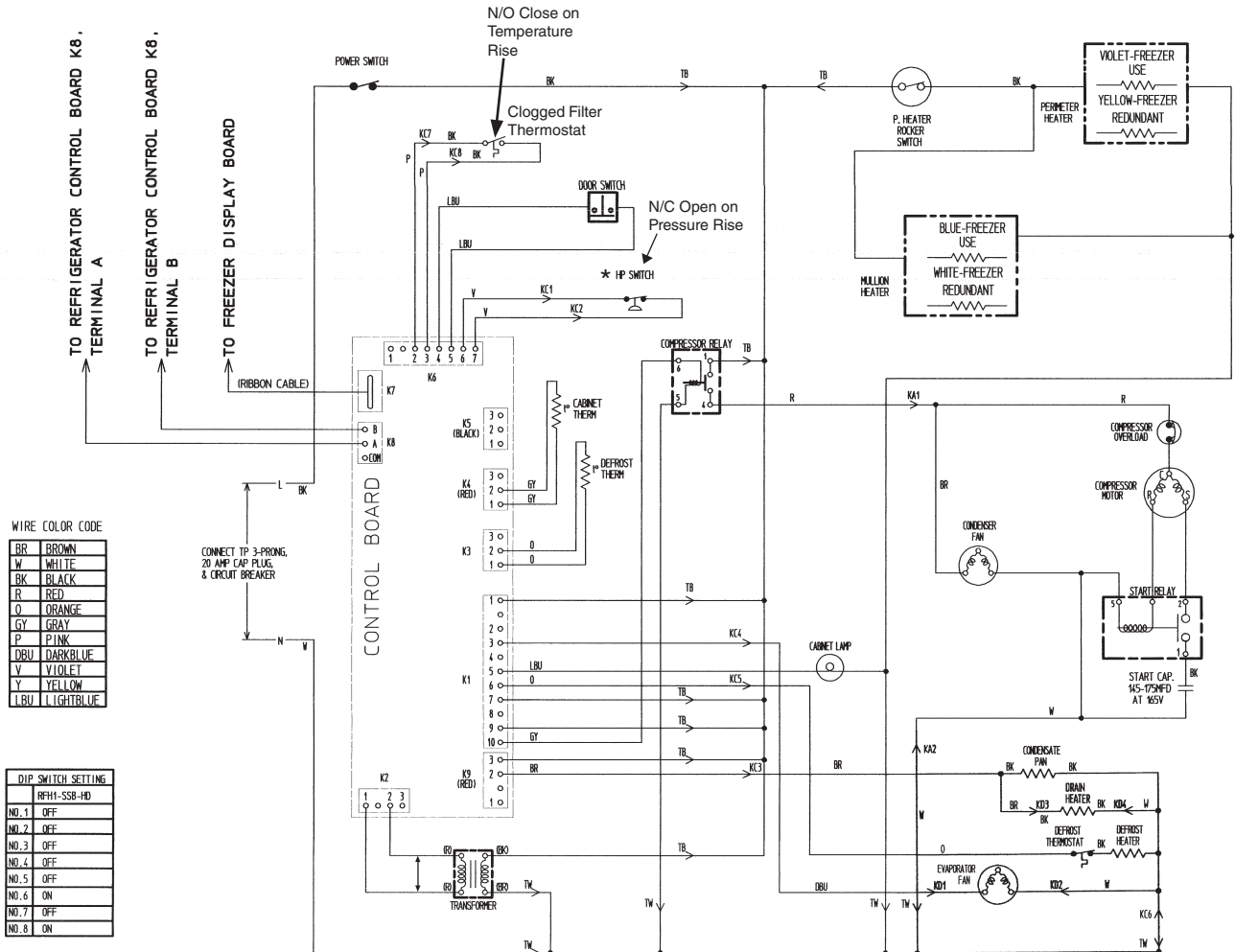

Control Transformer Output  
10VAC at 115VAC Input

\*Control Board  
Automatically Adjusts  
to N/O or N/C  
High-Pressure Switch

* High-Pressure Switch	
Cut-out	490±10 PSIG
Cut-in	370±20 PSIG

### NOTICE

Before diagnosing and/or servicing the unit, confirm that you have the proper wiring diagram by checking against the diagram located on the evaporator case cover.

# J. RFH1-SSB(-HS)(-HSE)

## 1. Refrigerator

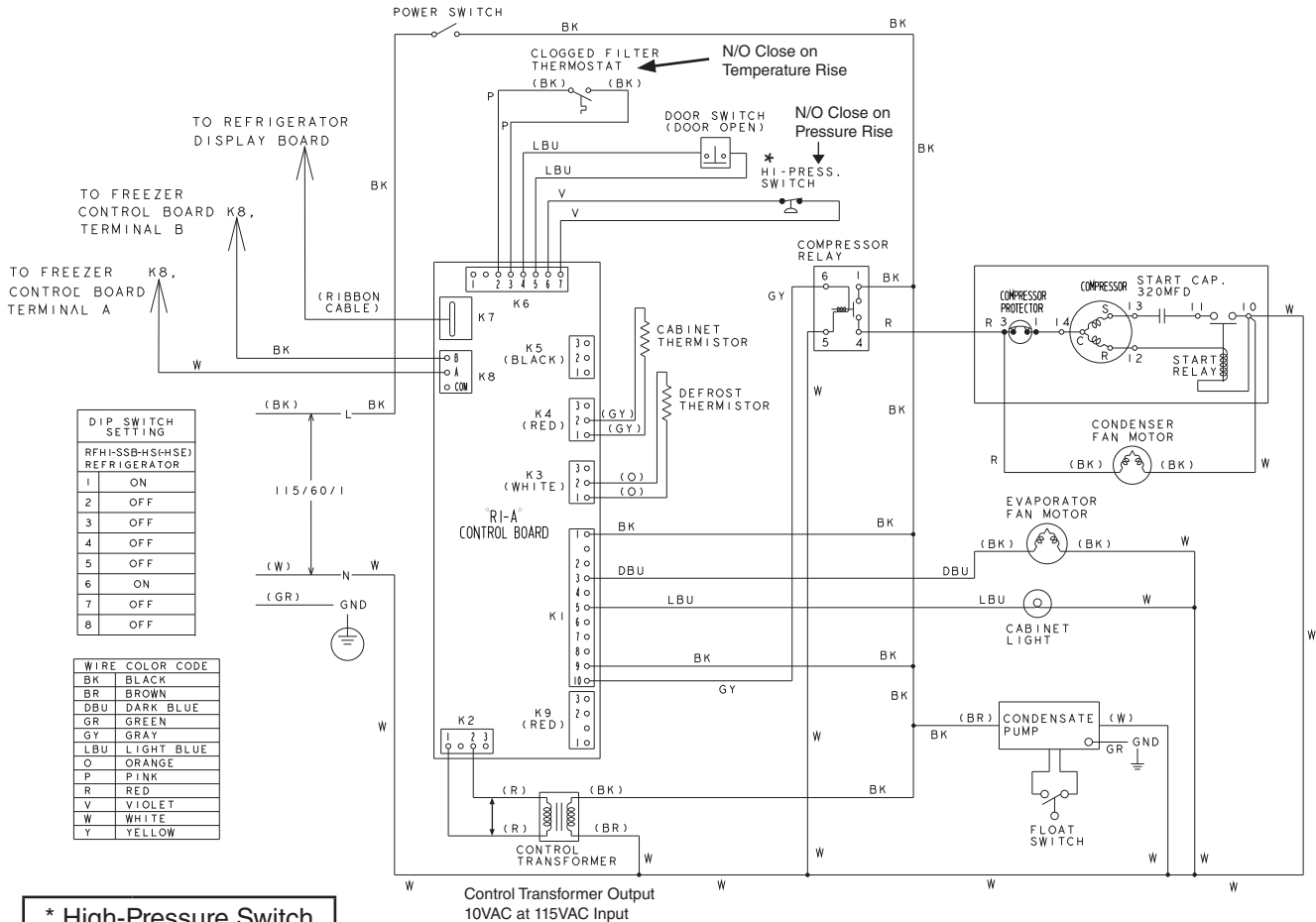

* High-Pressure Switch	
Cut-out	270±10 PSIG
Cut-in	190±20 PSIG

\*Control Board  
Automatically Adjusts  
to N/O or N/C  
High-Pressure Switch

### RFH1-SSB(-HS)(-HSE) Main Wiring Power Cord Connections

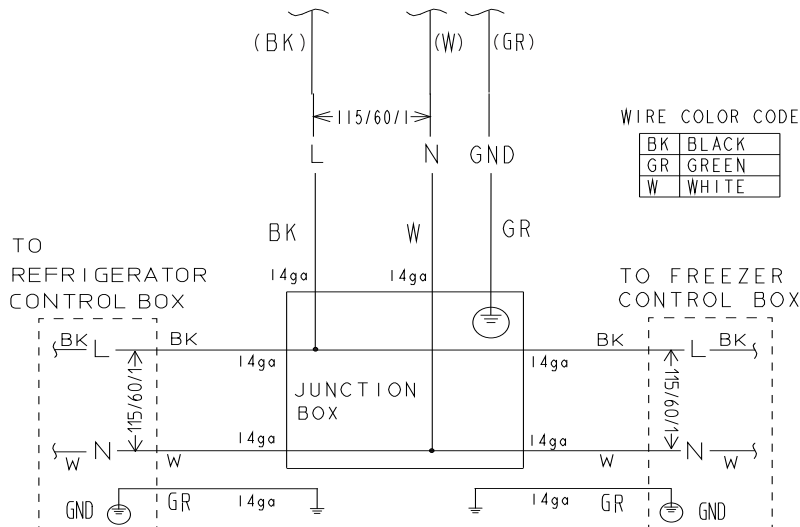

# J. RFH1-SSB(-HS)(-HSE)

## 2. Freezer

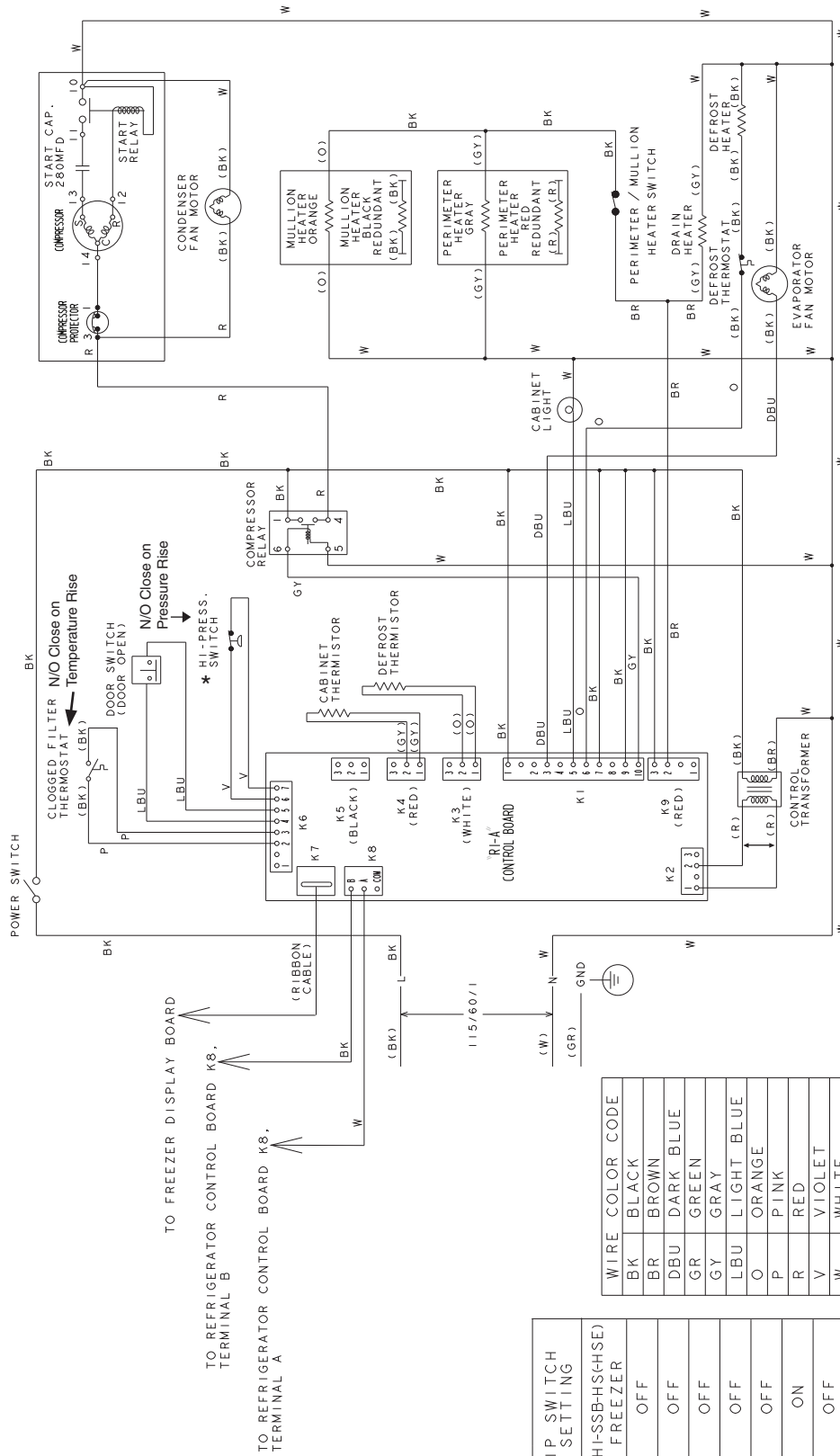

WIRE	COLOR	CODE
BK	BLACK	
BR	BROWN	
DBU	DARK BLUE	
GR	GREEN	
GY	GRAY	
LBU	LIGHT BLUE	
O	ORANGE	
P	PINK	
R	RED	
V	VIOLET	
W	WHITE	
Y	YELLOW	

DIP SWITCH SETTING	RFH1-SSB-HS(-HSE) FREEZER
1	OFF
2	OFF
3	OFF
4	OFF
5	OFF
6	ON
7	OFF
8	OFF

*High-Pressure Switch
Cut-out
490±10 PSIG
Cut-in
370±20 PSIG

\*Control Board Automatically Adjusts to N/O or N/C High-Pressure Switch

## K. RFH2-SSB(-HD)

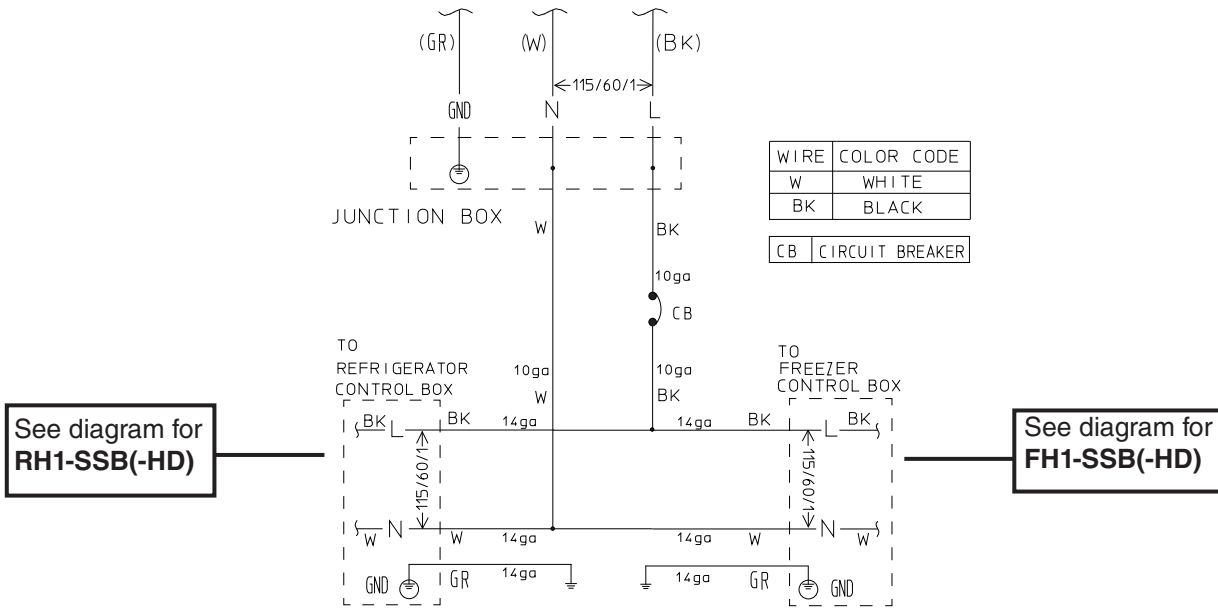

## L. RFH3-SSB(-HD)

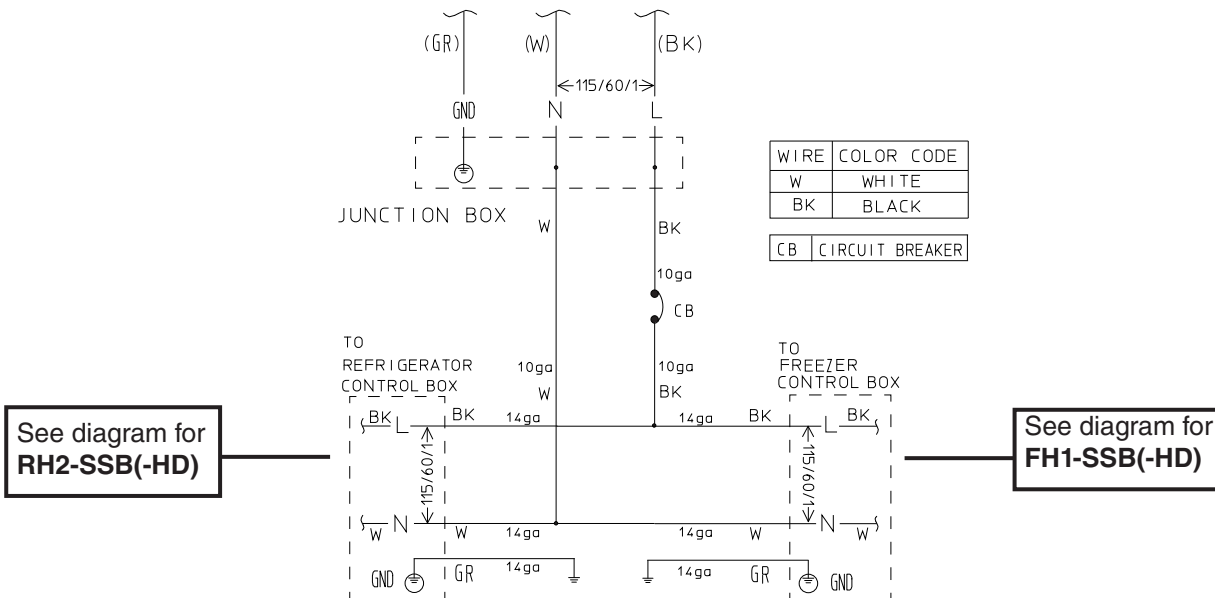

### NOTICE

Before diagnosing and/or servicing the unit, confirm that you have the proper wiring diagram by checking against the diagram located on the evaporator case cover.

# M. PTR1SSB01-10

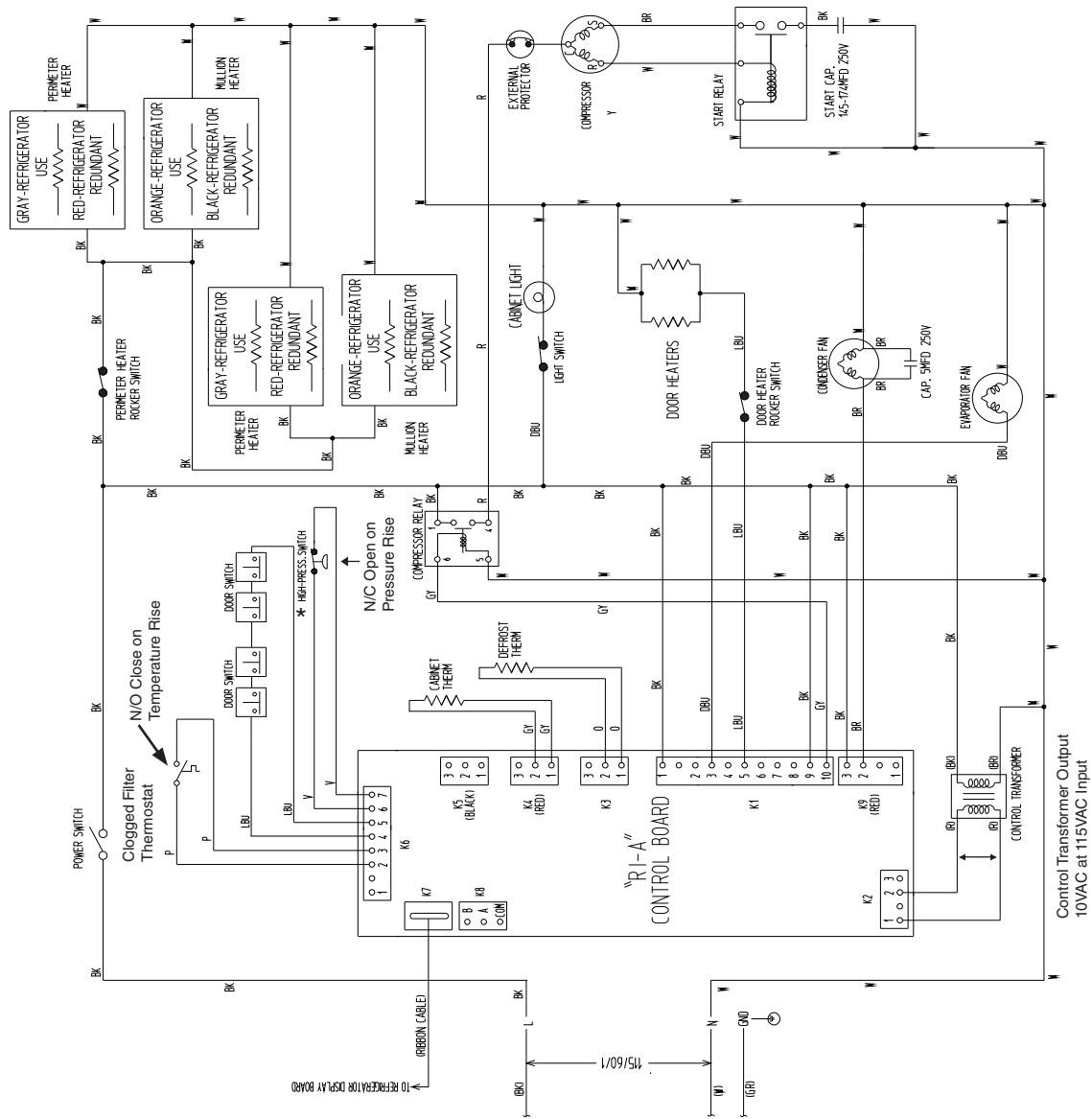

WIRE COLOR CODE  
 BK BLACK  
 BR BROWN  
 DBU DARK BLUE  
 GR GREEN  
 GY GRAY  
 LBU LIGHT BLUE  
 O ORANGE  
 P PINK  
 R RED  
 V VIOLET  
 W WHITE  
 Y YELLOW

DIP SWITCH SETTING	
PTR1-SSB01-10	
NO. 1	ON
NO. 2	ON
NO. 3	OFF
NO. 4	ON
NO. 5	OFF
NO. 6	OFF
NO. 7	OFF
NO. 8	OFF

* High-Pressure Switch	
Cut-out	490±10 PSIG
Cut-in	370±20 PSIG

\* Control Board Automatically Adjusts to N/O or N/C High-Pressure Switch

## NOTICE

Before diagnosing and/or servicing the unit, confirm that you have the proper wiring diagram by checking against the diagram located on the evaporator case cover.

# N. PTR1SSB(-FSFS)(-HSHS)

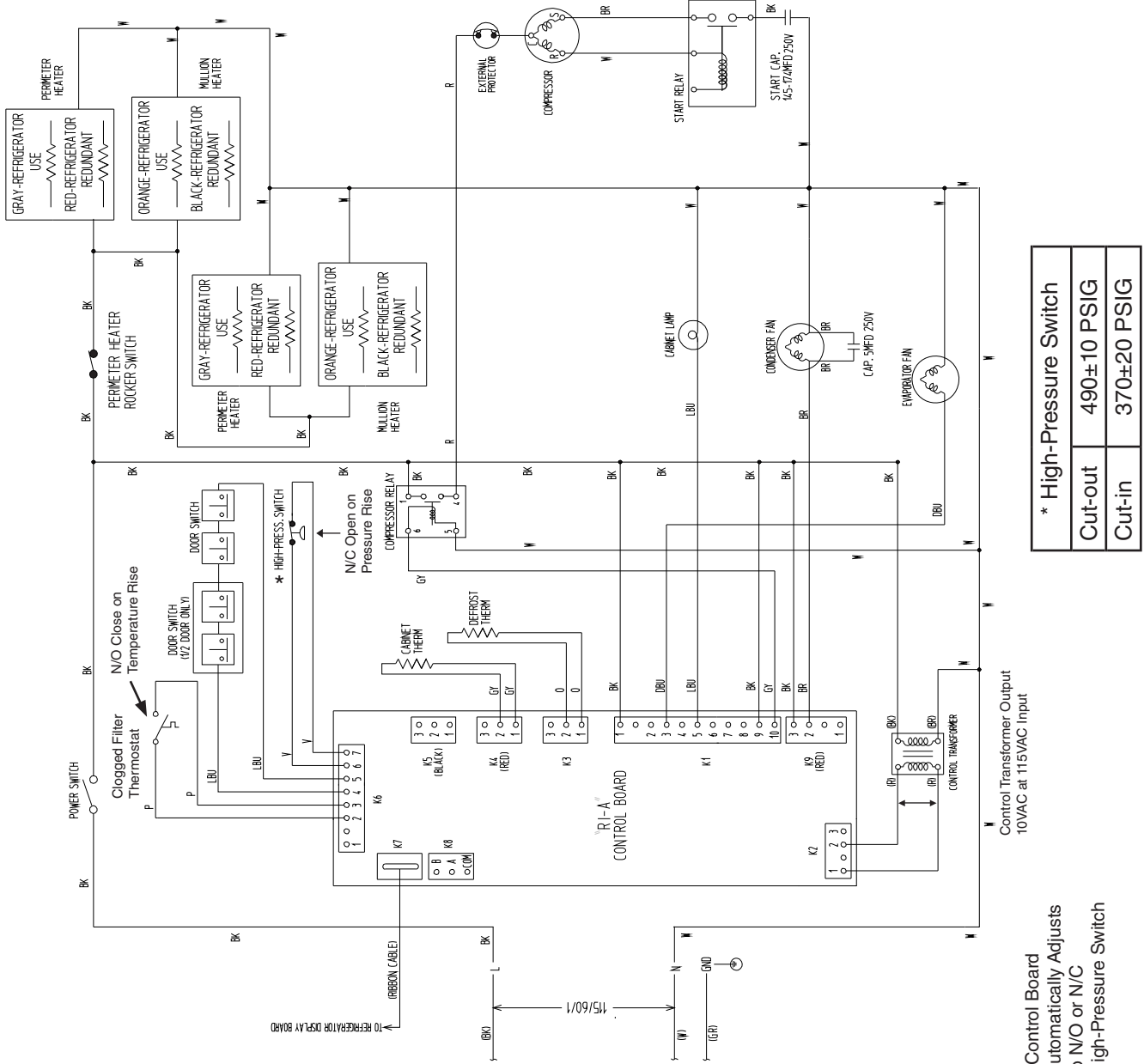

- WIRE COLOR CODE
- BK BLACK
  - BR BROWN
  - DBU DARK BLUE
  - GR GREEN
  - GY GRAY
  - LBV LIGHT BLUE
  - O ORANGE
  - P PINK
  - R RED
  - V VIOLET
  - W WHITE
  - Y YELLOW

D.I.P SWITCH SETTING	
PTR1-SSB(-FSFS)(-HSHS)	
NO.1	ON
NO.2	OFF
NO.3	OFF
NO.4	ON
NO.5	OFF
NO.6	OFF
NO.7	OFF
NO.8	OFF

* High-Pressure Switch	
Cut-out	490±10 PSIG
Cut-in	370±20 PSIG

\* Control Board Automatically Adjusts to N/O or N/C High-Pressure Switch

**NOTICE**

Before diagnosing and/or servicing the unit, confirm that you have the proper wiring diagram by checking against the diagram located on the evaporator case cover.

# O. PTR1SSB(-FGFG)(HGHS)(-HGHG) (Auxiliary Code T-5 and Earlier)

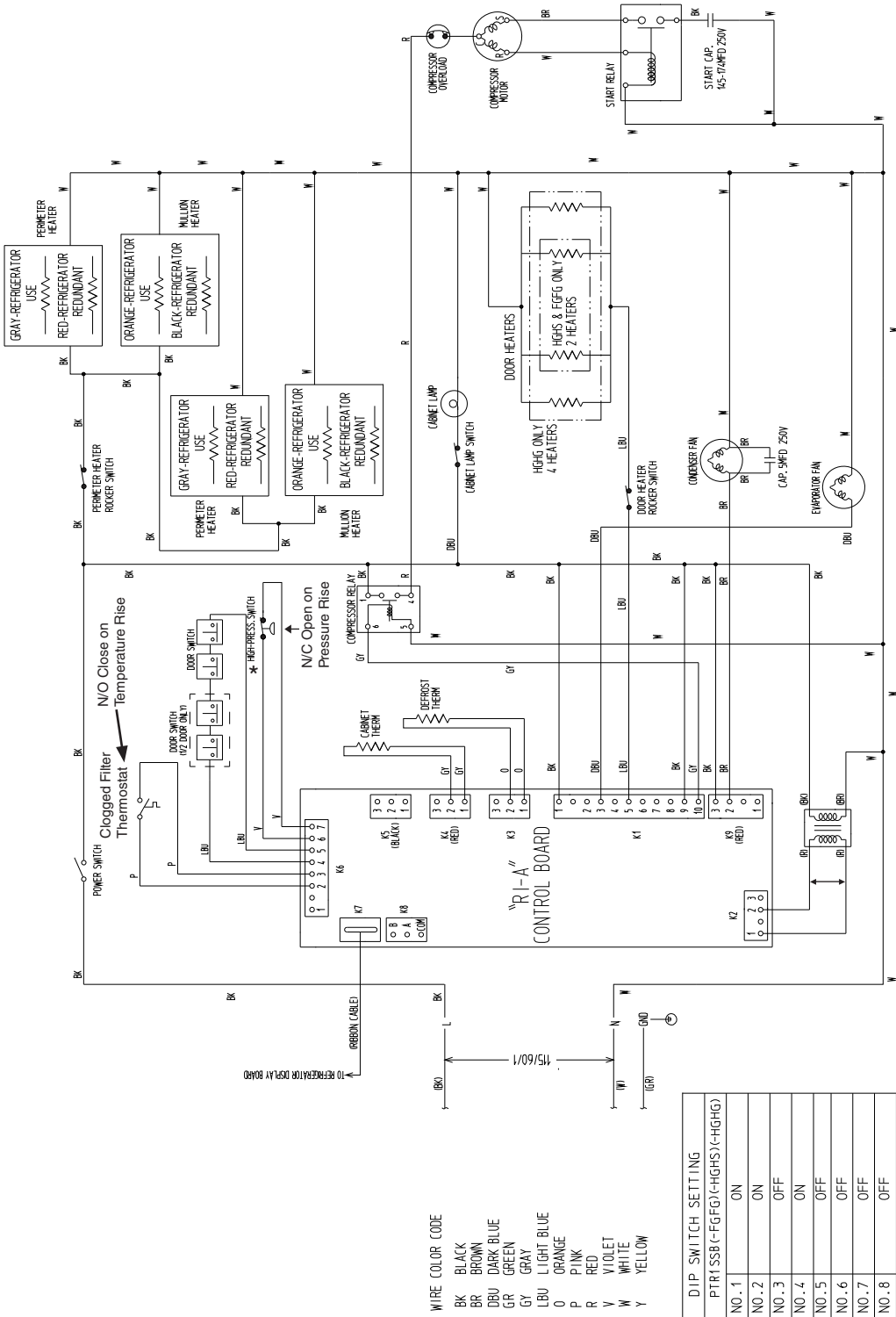

**WIRE COLOR CODE**

BK	BLACK
BR	BROWN
DBU	DARK BLUE
GR	GREEN
GT	GRAY
LBU	LIGHT BLUE
O	ORANGE
P	PINK
R	RED
V	VIOLET
W	WHITE
Y	YELLOW

**DIP SWITCH SETTING**

NO.	SETTING
NO. 1	ON
NO. 2	ON
NO. 3	OFF
NO. 4	ON
NO. 5	OFF
NO. 6	OFF
NO. 7	OFF
NO. 8	OFF

**\* High-Pressure Switch**

Cut-out	490±10 PSIG
Cut-in	370±20 PSIG

\* Control Board Automatically Adjusts to N/O or N/C High-Pressure Switch

Control Transformer Output  
10VAC at 115VAC Input

**NOTICE**

Before diagnosing and/or servicing the unit, confirm that you have the proper wiring diagram by checking against the diagram located on the evaporator case cover.

# P. PTR1SSB(-FGFG)(-HGHS)(-HGHG) (Auxiliary Code T-6 and Later)

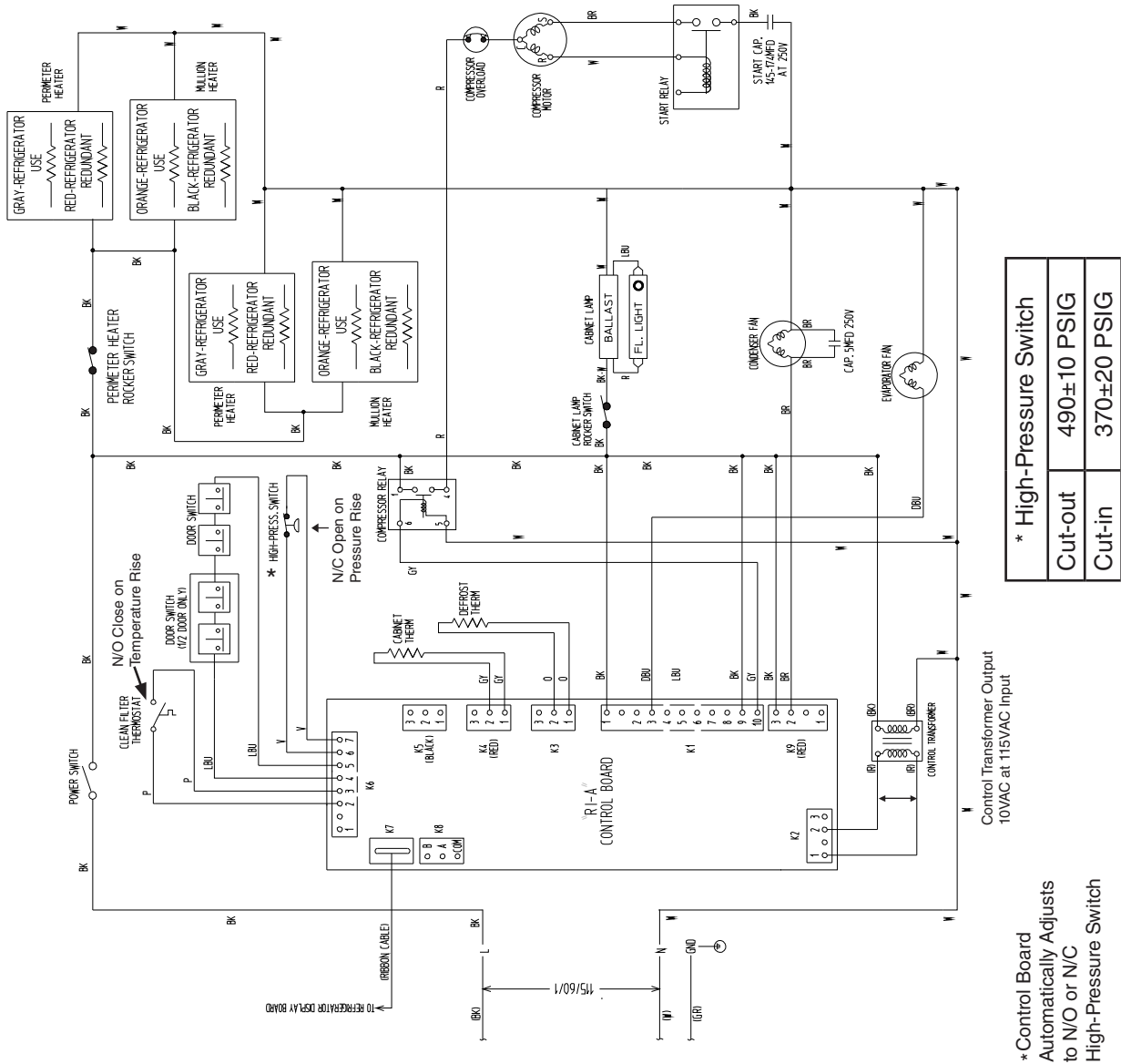

WIRE COLOR CODE

BK	BLACK
BR	BROWN
DBU	DARK BLUE
GR	GREEN
GY	GRAY
LBU	LIGHT BLUE
O	ORANGE
P	PINK
R	RED
V	VIOLET
W	WHITE
Y	YELLOW

DIP SWITCH SETTING	
PTR1SSB(-FGFG)(-HGHS)(-HGHG)	ON
NO. 1	ON
NO. 2	OFF
NO. 3	OFF
NO. 4	ON
NO. 5	OFF
NO. 6	OFF
NO. 7	OFF
NO. 8	OFF

* High-Pressure Switch	
Cut-out	490±10 PSIG
Cut-in	370±20 PSIG

\*Control Board Automatically Adjusts to N/O or N/C High-Pressure Switch

**NOTICE**

Before diagnosing and/or servicing the unit, confirm that you have the proper wiring diagram by checking against the diagram located on the evaporator case cover.

# Q. PTR2SSB(-FSFS)(-HSHS)

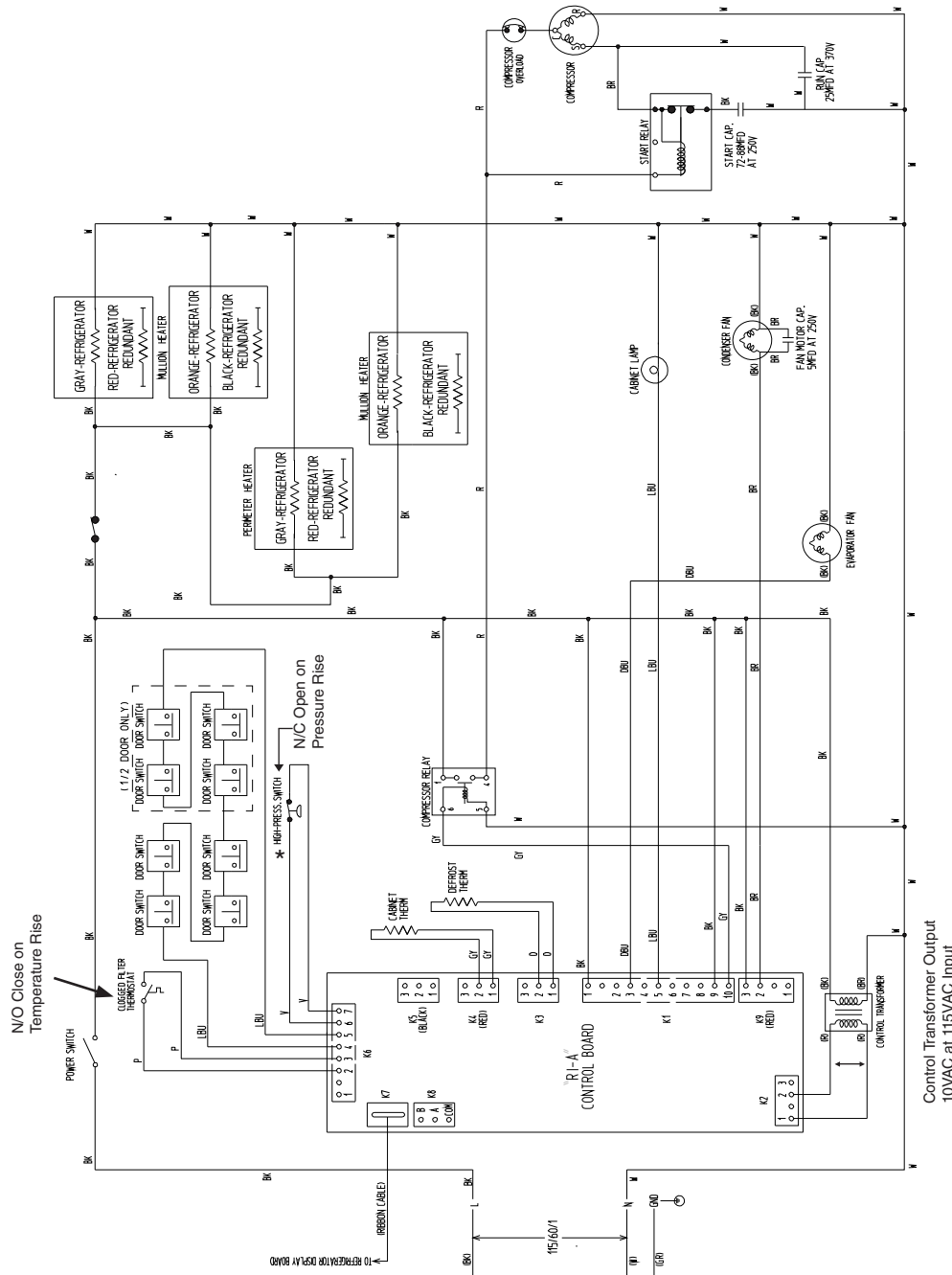

WIRE COLOR CODE

BK	BLACK
BR	BROWN
DBU	DARK BLUE
GR	GREEN
GY	GRAY
LBU	LIGHT BLUE
O	ORANGE
P	PINK
R	RED
V	VIOLET
W	WHITE
Y	YELLOW

DIP SWITCH SETTING

NO.	SETTING
PTR2SSB-FSFS(-HSHS)	
NO. 1	ON
NO. 2	OFF
NO. 3	OFF
NO. 4	ON
NO. 5	OFF
NO. 6	OFF
NO. 7	OFF
NO. 8	OFF

* High-Pressure Switch	
Cut-out	490±10 PSIG
Cut-in	370±20 PSIG

\* Control Board Automatically Adjusts to N/O or N/C High-Pressure Switch

**NOTICE**

Before diagnosing and/or servicing the unit, confirm that you have the proper wiring diagram by checking against the diagram located on the evaporator case cover.

# R. PTR2SSB(-FGFG)(-HGHG)

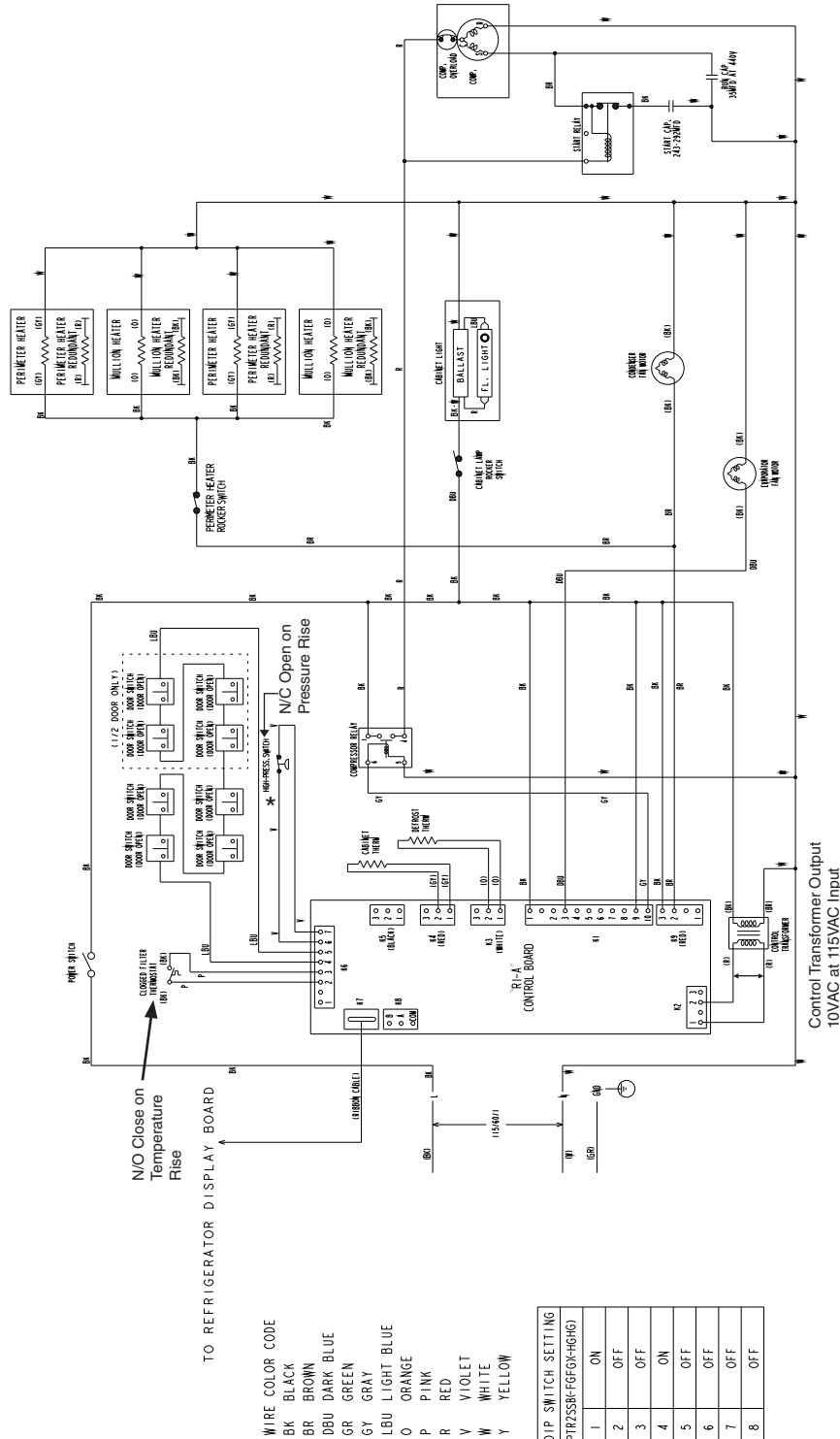

**NOTICE**

Before diagnosing and/or servicing the unit, confirm that you have the proper wiring diagram by checking against the diagram located on the evaporator case cover.

# S. RIR1-SSB

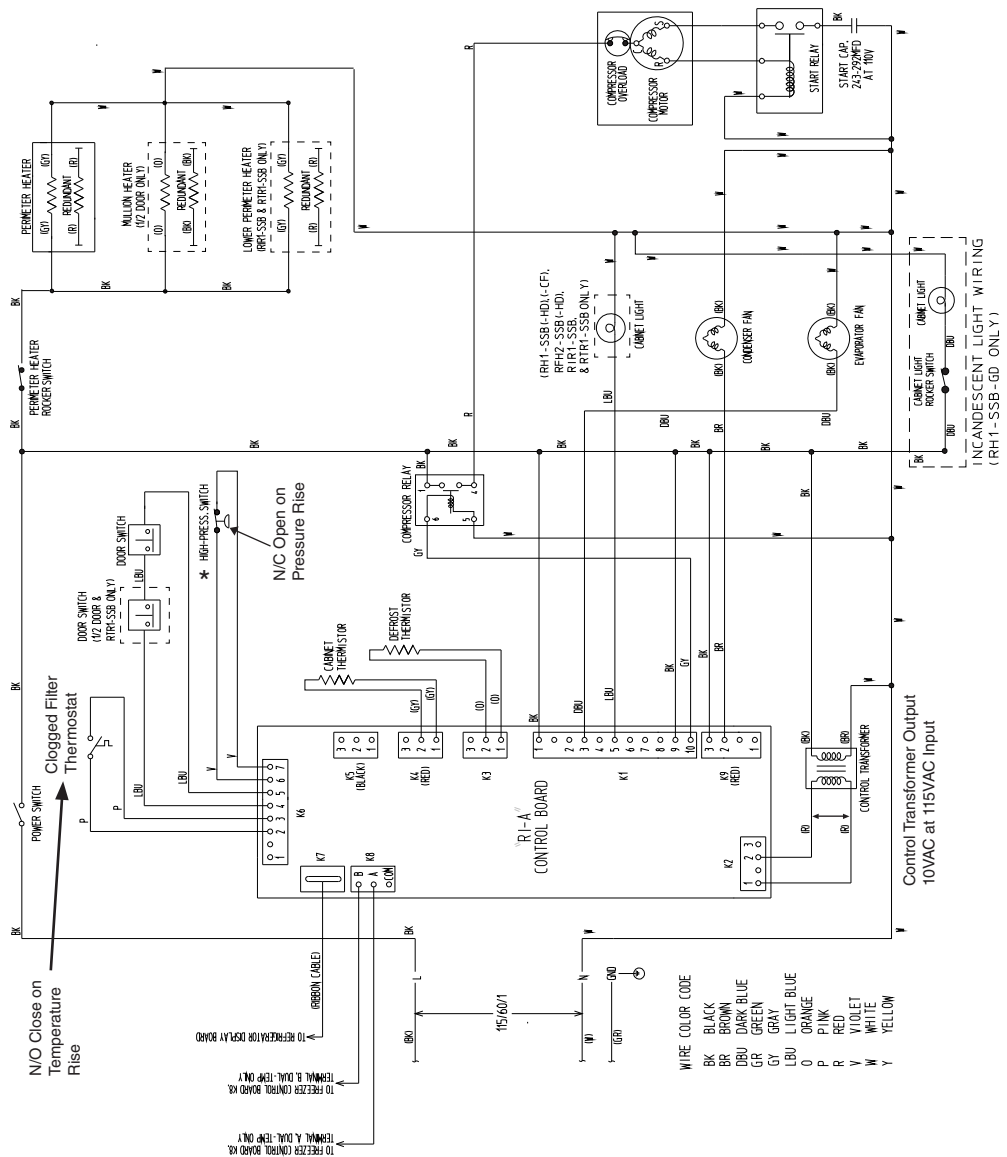

DIP SWITCH SETTING	
RIR1-SSB	ON
RTR1-SSB	OFF
NO.1	OFF
NO.2	OFF
NO.3	OFF
NO.4	OFF
NO.5	OFF
NO.6	OFF
NO.7	OFF
NO.8	OFF

WIRE COLOR CODE	
BK	BLACK
BR	BROWN
DBU	DARK BLUE
GR	GREEN
GT	GRAY
LB	LIGHT BLUE
O	ORANGE
P	PINK
R	RED
V	VIOLET
W	WHITE
Y	YELLOW

* High-Pressure Switch	
Cut-out	490±10 PSIG
Cut-in	370±20 PSIG

\* Control Board Automatically Adjusts to N/O or N/C High-Pressure Switch

**NOTICE**

Before diagnosing and/or servicing the unit, confirm that you have the proper wiring diagram by checking against the diagram located on the evaporator case cover.

# T. RIR2-SSB

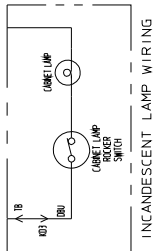
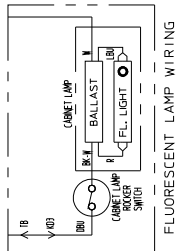

- WIRE COLOR CODE
- BK BLACK
  - BR BROWN
  - DBU DARK BLUE
  - GR GREEN
  - GY GRAY
  - LBU LIGHT BLUE
  - O ORANGE
  - P PINK
  - R RED
  - W WHITE
  - Y YELLOW

DIP SWITCH SETTING	
RH2-SSB	RPH3-SSB
RH2-SSB-HD	RPH3-SSB-HD
RH2-SSB-FG	
RH2-SSB-HG	
RH2-SSB-WH1	
RIR2-SSB	
NO. 1	ON
NO. 2	OFF
NO. 3	OFF
NO. 4	OFF
NO. 5	OFF
NO. 6	OFF
NO. 7	OFF
NO. 8	OFF

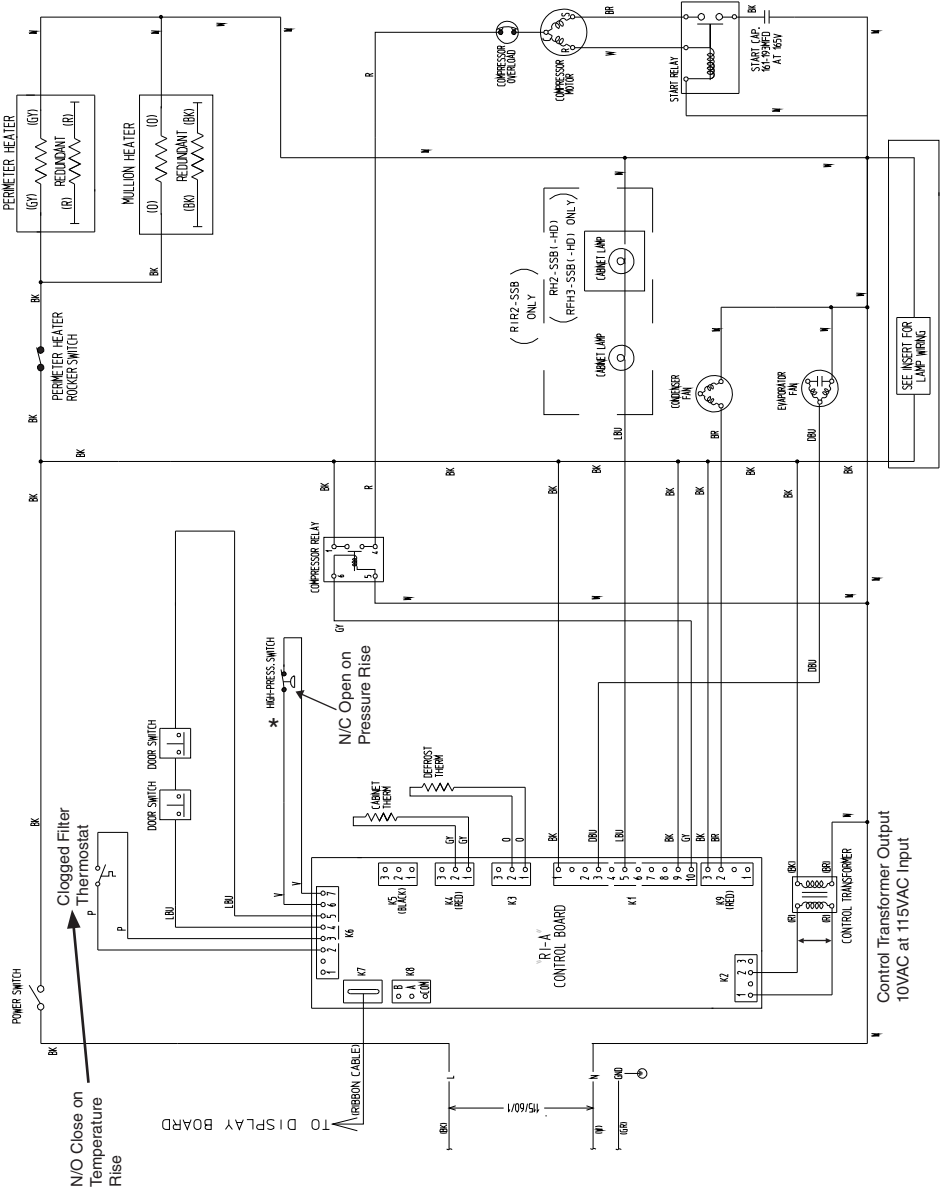

* High-Pressure Switch	
Cut-out	490±10 PSIG
Cut-in	370±20 PSIG

\*Control Board Automatically Adjusts to N/O or N/C High-Pressure Switch

**NOTICE**

Before diagnosing and/or servicing the unit, confirm that you have the proper wiring diagram by checking against the diagram located on the evaporator case cover.

# U. RIR2-SSB51-02

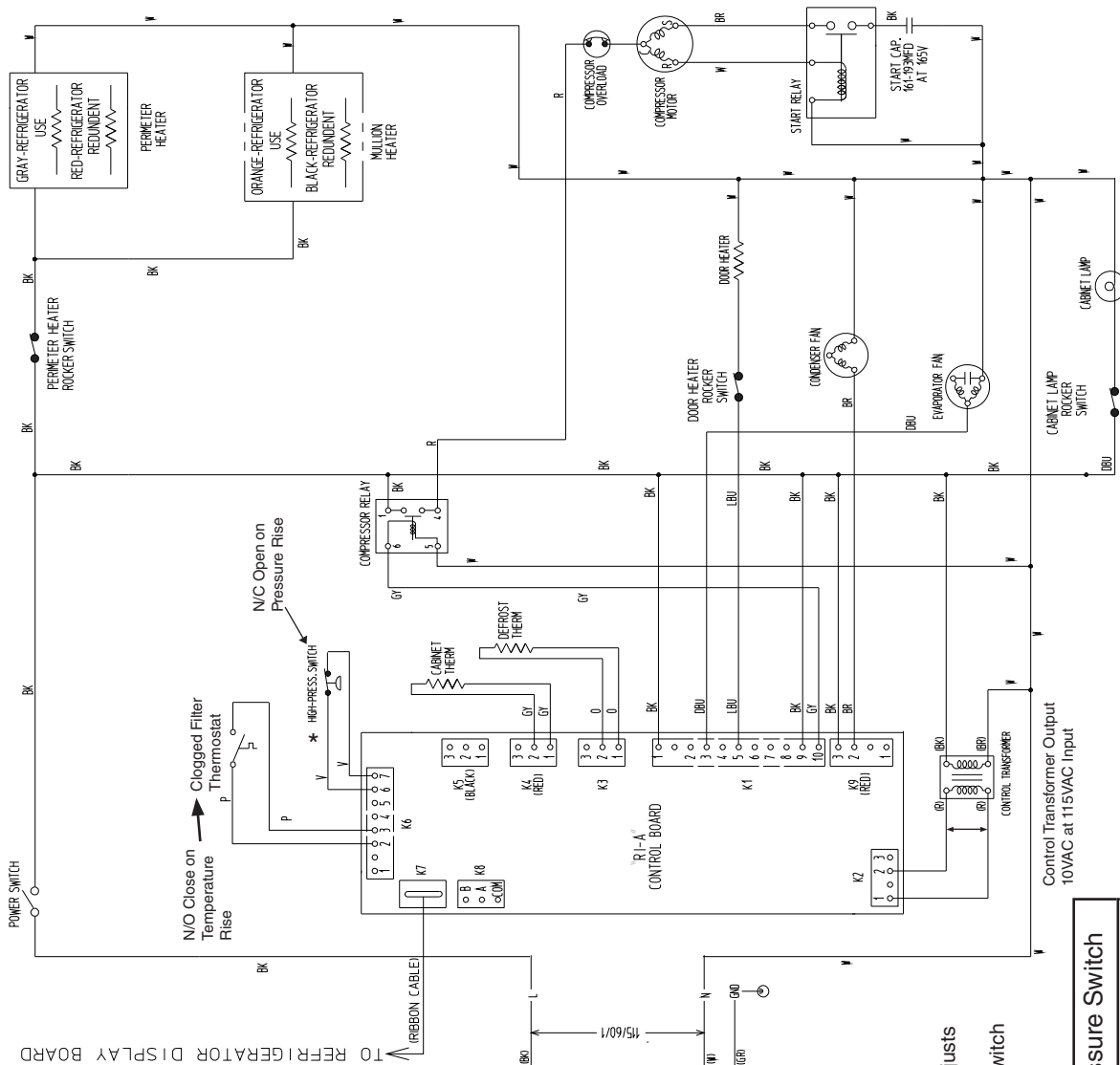

WIRE COLOR CODE

BK	BLACK
BR	BROWN
DRU	DARK BLUE
GR	GREEN
GY	GRAY
LBU	LIGHT BLUE
O	ORANGE
P	PINK
R	RED
V	VIOLET
W	WHITE
Y	YELLOW

DIP SWITCH SETTING

RIR2-SSB51-02	
NO. 1	ON
NO. 2	ON
NO. 3	OFF
NO. 4	OFF
NO. 5	OFF
NO. 6	OFF
NO. 7	OFF
NO. 8	OFF

\* Control Board Automatically Adjusts to N/O or N/C High-Pressure Switch

* High-Pressure Switch	
Cut-out	490±10 PSIG
Cut-in	370±20 PSIG

**NOTICE**

Before diagnosing and/or servicing the unit, confirm that you have the proper wiring diagram by checking against the diagram located on the evaporator case cover.

# V. RTR1-SSB

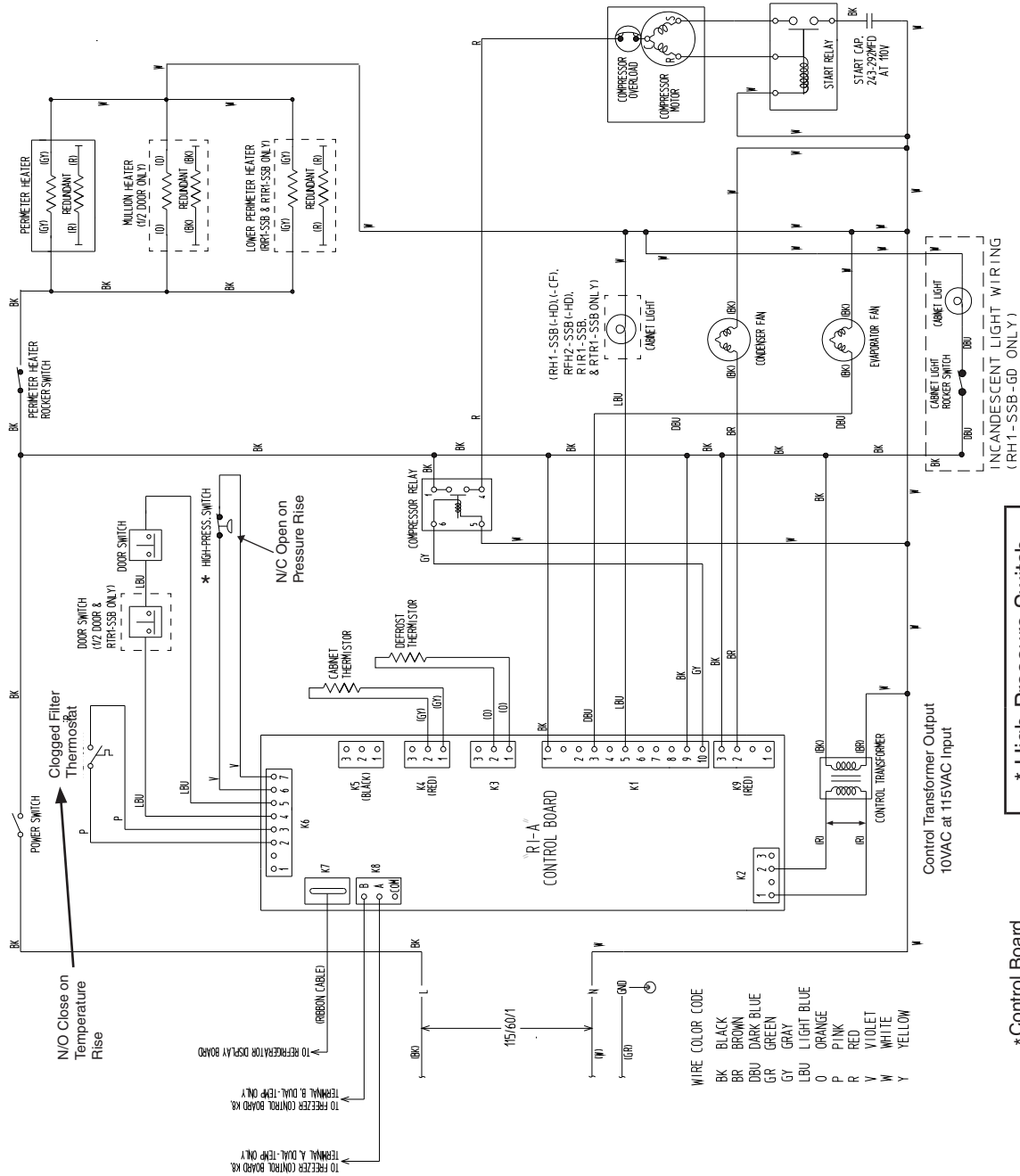

WIRE COLOR CODE

BK	BLACK
BR	BROWN
DBU	DARK BLUE
GR	GREEN
GY	GRAY
LBU	LIGHT BLUE
O	ORANGE
P	PINK
R	RED
V	VIOLET
W	WHITE
Y	YELLOW

DIP SWITCH SETTING

R1R1-SSB	
NO. 1	ON
NO. 2	OFF
NO. 3	OFF
NO. 4	OFF
NO. 5	OFF
NO. 6	OFF
NO. 7	OFF
NO. 8	OFF

\* High-Pressure Switch

Cut-out	490±10 PSIG
Cut-in	370±20 PSIG

\* Control Board Automatically Adjusts to N/O or N/C High-Pressure Switch

**NOTICE**

Before diagnosing and/or servicing the unit, confirm that you have the proper wiring diagram by checking against the diagram located on the evaporator case cover.