

Hoshizaki America, Inc.

Self-Contained Flaker

Model
F-500BAF



“A Superior Degree
of Reliability”

www.hoshizaki.com

SERVICE MANUAL



Number: 73074
Issued: 3-2-1999
Revised: 12-26-2003

IMPORTANT

Only qualified service technicians should attempt to service or maintain this icemaker. No service or maintenance should be undertaken until the technician has thoroughly read this Service Manual.

HOSHIZAKI provides this manual primarily to assist qualified service technicians in the service and maintenance of the icemaker.

Should the reader have any questions or concerns which have not been satisfactorily addressed, please call or write to the HOSHIZAKI Technical Support Department for assistance.

HOSHIZAKI AMERICA, INC.
618 Highway 74 South
Peachtree City, GA 30269

Attn: HOSHIZAKI Technical Support Department

Phone: 1-800-233-1940 Technical Service
(770) 487-2331
Fax: (770) 487-3360

Web Site: www.hoshizakiamerica.com

Note: To expedite assistance, all correspondence/communication MUST include the following information:

- Model Number
- Serial Number
- Complete and detailed explanation of the problem

Please review this manual. It should be read carefully before the icemaker is serviced or maintenance operations are performed. Only qualified service technicians should service and maintain the icemaker. This manual should be made available to the technician prior to service or maintenance.

CONTENTS

I. Specifications	5
F-500BAF	5
F-500BAF-C	6
II. General Information	7
1. Construction	7
F-500BAF, F-500BAF-C	7
2. Ice Making Unit	8
3. Control Box Layout	9
F-500BAF, F-500BAF-C	9
4. Timer Board	10
[a] Solid-State Control	10
[b] Timer Board	10
[c] Sequence	11
III. Technical Information	14
1. Water Circuit and Refrigerant Circuit	14
F-500BAF, F-500BAF-C	14
2. Wiring Diagram	15
F-500BAF, F-500BAF-C	15
3. Sequence of Electrical Circuit	16
F-500BAF, F-500BAF-C	16
4. Timing Chart	21
5. Performance Data	24
F-500BAF	24
F-500BAF-C	25
IV. Service Diagnosis	26
1. No Ice Production	26
2. Low Ice Production	29
3. Other	30
V. Removal and Replacement of Components	31
1. Service for Refrigerant Lines	31
[a] Refrigerant Recovery	31
[b] Evacuation and Recharge [R-404A]	31
2. Brazing	32
3. Removal and Replacement of Compressor	33
4. Removal and Replacement of Drier	34
5. Removal and Replacement of Expansion Valve	35
6. Removal and Replacement of Evaporator Assembly	36
7. Removal and Replacement of Fan Motor	40
8. Removal and Replacement of Control Water Valve	40

VI. Cleaning and Maintenance	41
1. Preparing the Icemaker for Long Storage	41
2. Cleaning and Sanitizing Instructions	42
[a] Cleaning Solution	42
[b] Cleaning Procedure	42
[c] Sanitizing Solution	43
[d] Sanitizing Procedure - Initial	44
[e] Sanitizing Procedure - Final	44
3. Maintenance Instructions	46

I. Specifications

F-500BAF

AC SUPPLY VOLTAGE	115/60/1		
COMPRESSOR	120 V	7.9 RLA	51 LRA
GEAR MOTOR	120 V	1.6 FLA	1/6 HP
FAN MOTOR	120 V	0.85 FLA	1/15 HP
OTHER	120 V	0.03 A	
MAXIMUM FUSE SIZE	20 A		
MAX. HACR BREAKER (USA ONLY)	20 A		
MAX. CIRC. BREAKER (CANADA ONLY)	20 A		
MINIMUM CIRCUIT AMPACITY	20 A		
APPROXIMATE ICE PRODUCTION PER 24 HR. lbs./day (kg/day) Reference without *marks	Ambient Temp.(-F)	WATER TEMP. (-F)	
		50	70
	70	* 478 (217)	458 (208)
	80	419 (190)	400 (182)
	90	366 (166)	* 359 (163)
	100	320 (145)	* 287 (130)
SHAPE OF ICE	Flake		
ICE QUALITY	Approx. 70%, Ice (90/70-F, Conductivity 200 μ s/cm)		
APPROXIMATE STORAGE CAPACITY	250 lbs.		
ELECTRIC & WATER CONSUMPTION	90/70-F	70/50-F	
ELECTRIC W (kWH/100 lbs.)	900 (6.0)	854 (4.3)	
POTABLE WATER gal./24HR (gal./100 lbs.)	43 (12)	57 (12)	
EXTERIOR DIMENSIONS (WxDxH)	38" x 29" x 36" (965 x 735 x 915 mm)		
EXTERIOR FINISH	PVC Coated Galvanized Steel; Galvanized Steel (Rear); Stainless Steel (Top)		
WEIGHT	Net 210 lbs. (95 kg), Shipping 245 lbs. (111 kg)		
CONNECTIONS -ELECTRIC	Permanent Connection		
-WATER SUPPLY	Inlet 1/2" FPT		
-DRAIN	Drain Pan 3/4" FPT Bin Drain 3/4" FPT		
ICE MAKING SYSTEM	Auger type		
HARVESTING SYSTEM	Direct Driven Auger (1/6 HP Gear Motor)		
ICE MAKING WATER CONTROL	Float Switch		
COOLING WATER CONTROL	N/A		
BIN CONTROL SYSTEM	Mechanical Bin Control (Proximity Sw.)		
COMPRESSOR	Hermetic, Model RS 43C1E-CAA		
CONDENSER	Air-cooled, Fin and tube type		
EVAPORATOR	Copper Tube on Cylinder		
REFRIGERANT CONTROL	Thermostatic Expansion Valve		
REFRIGERANT CHARGE	R-404A, 1 lb. (470 g)		
DESIGN PRESSURE	High 460 PSIG, Low 290 PSIG		
P.C. BOARD CIRCUIT PROTECTION	High Voltage Cut-off Relay		
COMPRESSOR PROTECTION	Auto-reset Overload Protector		
GEAR MOTOR PROTECTION	Manual reset Circuit Breaker		
REFRIGERANT CIRCUIT PROTECTION	Auto-reset High Pressure Control Switch		
LOW WATER PROTECTION	Float Switch and Timer		
ACCESSORIES -SUPPLIED	Ice Scoop, Spare Fuse		
-REQUIRED	Legs		
OPERATING CONDITIONS	VOLTAGE RANGE	104 - 127 V	
	AMBIENT TEMP.	45 - 100-F	
	WATER SUPPLY TEMP.	45 - 90-F	
	WATER SUPPLY PRESSURE	10 - 113 PSIG	
DRAWING NO. (DIMENSIONS)	339850—		

We reserve the right to make changes in specifications and design without prior notice.

F-500BAF-C

AC SUPPLY VOLTAGE	115/60/1			
COMPRESSOR	120 V	7.9 RLA	51 LRA	
GEAR MOTOR	120 V	1.6 FLA	1/6 HP	
FAN MOTOR	120 V	0.85 FLA	1/15 HP	
OTHER	120 V	0.03 A		
MAXIMUM FUSE SIZE	20 A			
MAX. HACR BREAKER (USA ONLY)	20 A			
MAX. CIRC. BREAKER (CANADA ONLY)	20 A			
MINIMUM CIRCUIT AMPACITY	20 A			
APPROXIMATE ICE PRODUCTION PER 24 HR. lbs./day (kg/day) Reference without *marks	Ambient	WATER TEMP. (-F)		
	Temp.(-F)	50	70	90
	70	* 431 (196)	415 (188)	398 (181)
	80	381 (173)	365 (166)	350 (159)
	90	336 (152)	* 333 (151)	308 (140)
	100	295 (134)	283 (128)	* 263 (119)
SHAPE OF ICE	Cubelet			
ICE QUALITY	Approx. 80% , Ice (90/70-F, Conductivity 200 μ s/cm)			
APPROXIMATE STORAGE CAPACITY	250 lbs.			
ELECTRIC & WATER CONSUMPTION	90/70-F	70/50-F		
ELECTRIC W (kWH/100 lbs.)	903 (6.5)	864 (4.8)		
POTABLE WATER	40 (12)	52 (12)		
	gal./24HR (gal./100 lbs.)			
EXTERIOR DIMENSIONS (WxDxH)	38" x 29" x 36" (965 x 735 x 915 mm)			
EXTERIOR FINISH	PVC Coated Galvanized Steel; Galvanized Steel (Rear); Stainless Steel (Top)			
WEIGHT	Net 210 lbs. (95 kg), Shipping 245 lbs. (111 kg)			
CONNECTIONS -ELECTRIC	Permanent Connection			
-WATER SUPPLY	Inlet 1/2" FPT			
-DRAIN	Drain Pan 3/4" FPT Bin Drain 3/4" FPT			
ICE MAKING SYSTEM	Auger type			
HARVESTING SYSTEM	Direct Driven Auger (1/6 HP Gear Motor)			
ICE MAKING WATER CONTROL	Float Switch			
COOLING WATER CONTROL	N/A			
BIN CONTROL SYSTEM	Mechanical Bin Control (Proximity Sw.)			
COMPRESSOR	Hermetic, Model RS 43C 1E-CAA			
CONDENSER	Air-cooled, Fin and tube type			
EVAPORATOR	Copper Tube on Cylinder			
REFRIGERANT CONTROL	Thermostatic Expansion Valve			
REFRIGERANT CHARGE	R-404A, 1 lb. (470 g)			
DESIGN PRESSURE	High 460 PSIG, Low 290 PSIG			
P.C. BOARD CIRCUIT PROTECTION	High Voltage Cut-off Relay			
COMPRESSOR PROTECTION	Auto-reset Overload Protector			
GEAR MOTOR PROTECTION	Manual reset Circuit Breaker			
REFRIGERANT CIRCUIT PROTECTION	Auto-reset High Pressure Control Switch			
LOW WATER PROTECTION	Float Switch and Timer			
ACCESSORIES -SUPPLIED	Ice Scoop, Spare Fuse			
-REQUIRED	Legs			
OPERATING CONDITIONS	VOLTAGE RANGE	104 - 127 V		
	AMBIENT TEMP.	45 - 100-F		
	WATER SUPPLY TEMP.	45 - 90-F		
	WATER SUPPLY PRESSURE	10 - 113 PSIG		
DRAWING NO. (DIMENSIONS)	339850—			

We reserve the right to make changes in specifications and design without prior notice.

II. General Information

1. Construction

F-500BAF, F-500BAF-C

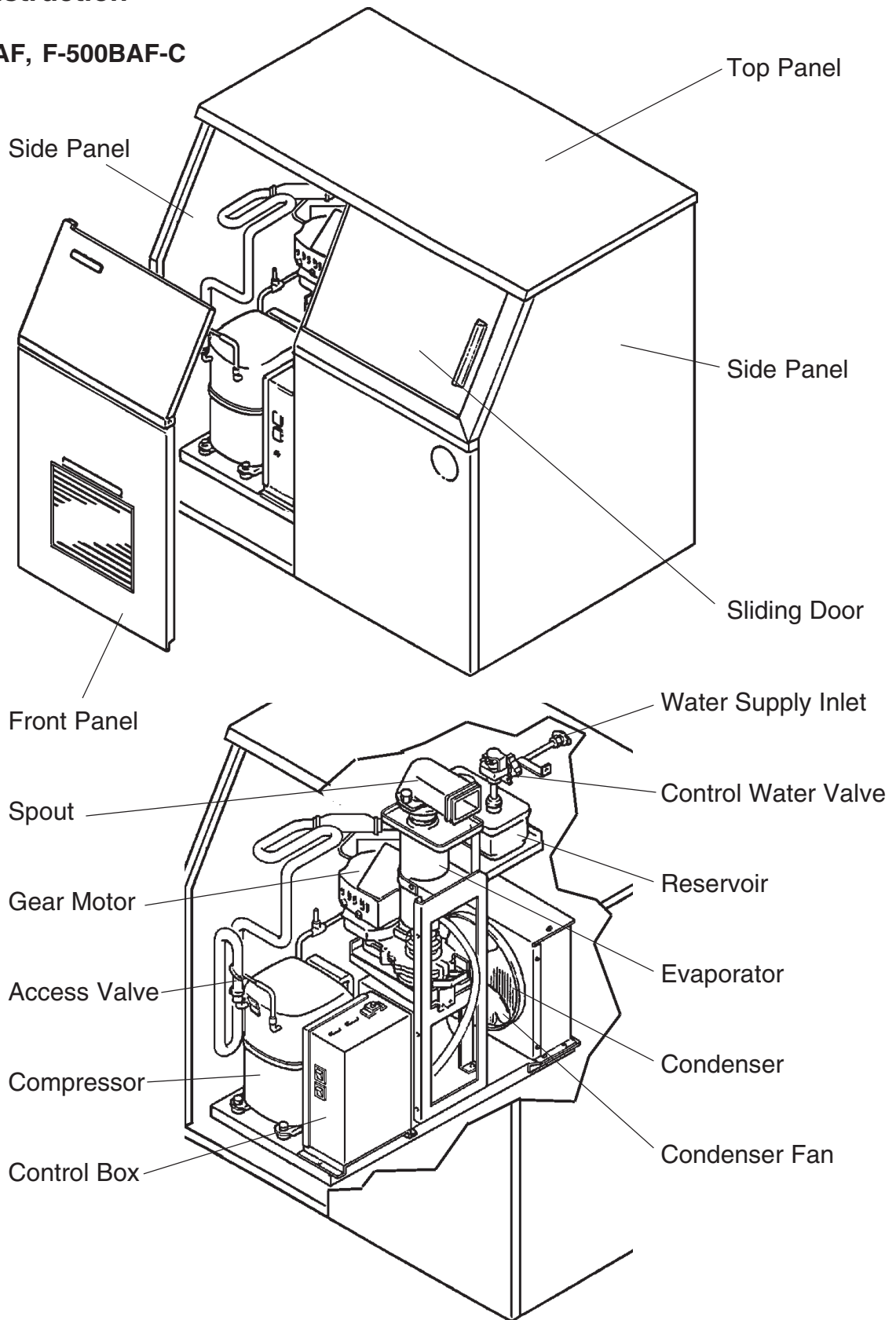

2. Ice Making Unit

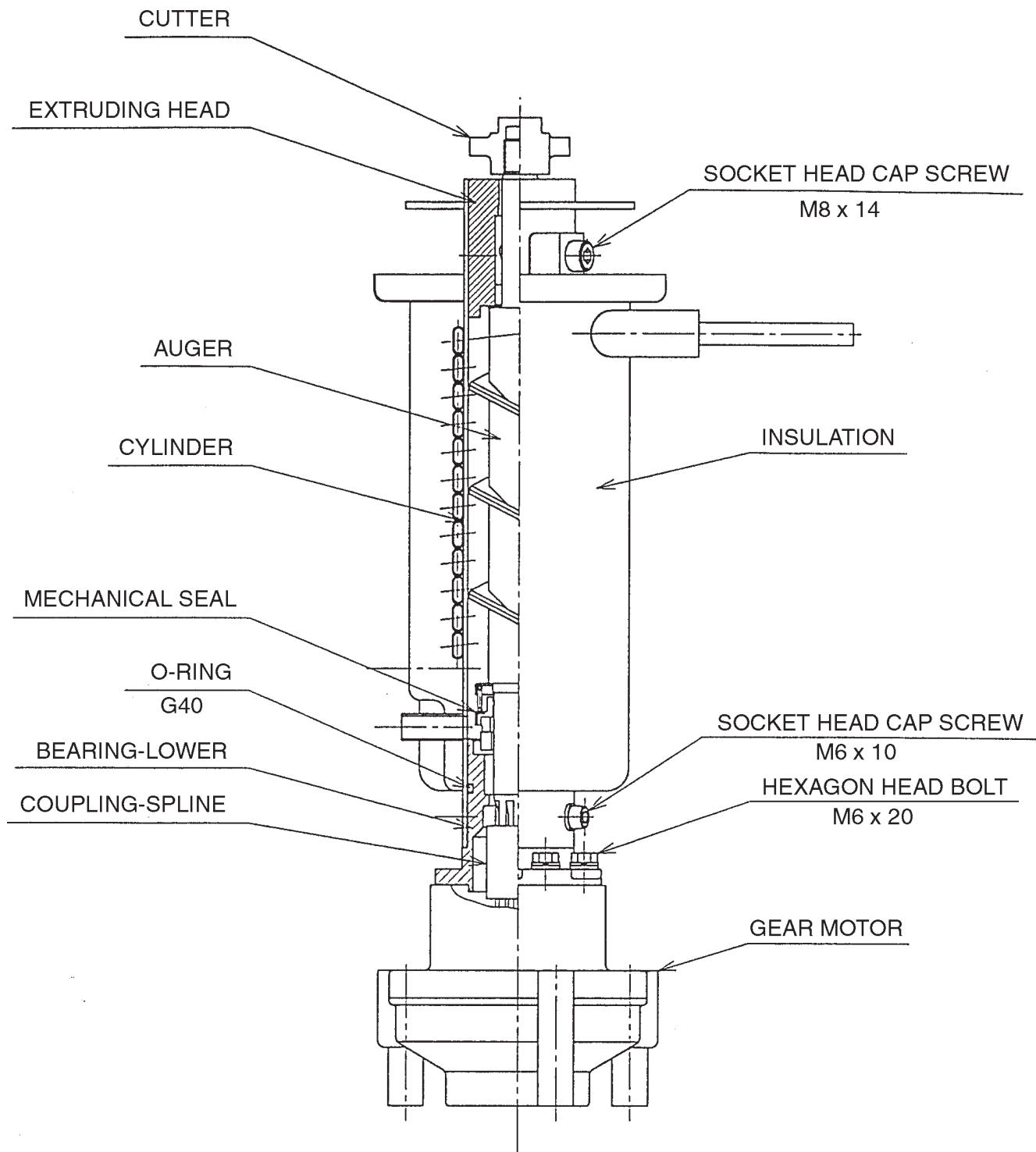

3. Control Box Layout

F-500BAF, F-500BAF-C

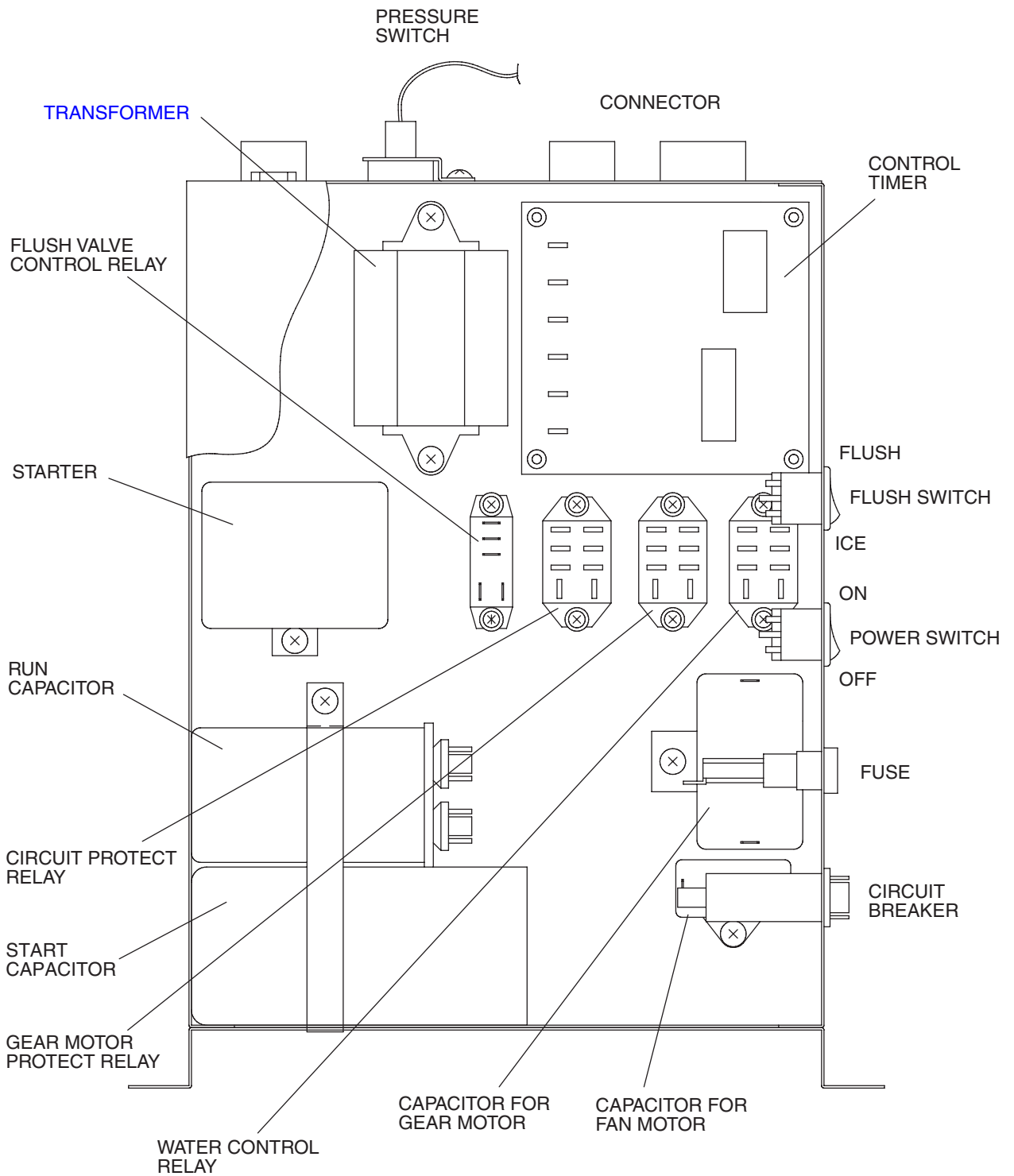

Note: The above component names are identical with the wiring label, but not with the parts list.

4. Timer Board

[a] Solid-State Control

- 1) A HOSHIZAKI exclusive solid-state control is employed in the self-contained flaker icemakers.
- 2) A printed circuit board (hereafter called “timer board”) includes a stable and high quality control system.
- 3) All models are pre-tested and factory adjusted.

[b] Timer Board

CAUTION

1. Fragile, handle very carefully.
2. A timer board contains CMOS (Complementary Metal-Oxide Semiconductor) integrated circuits, which are susceptible to failure due to static discharge. It is especially important to use an anti-static wrist strap when handling or replacing the board.
3. Do not touch the electronic devices on the board or the back of the board to prevent damage to the board.
4. Do not change wiring and connections. Especially, never misconnect terminals.
5. Do not fix the electronic devices or parts on the board in the field. Always replace the whole board assembly when it goes bad.

The icemaker is controlled by the timer board for the following purposes:

- 1) To prevent the gear motor and the compressor from starting or stopping simultaneously.
- 2) To reduce remaining ice in the refrigeration casing.
- 3) To protect the unit in case of low water and low water pressure.
- 4) To protect the unit in case the bin control causes chattering.

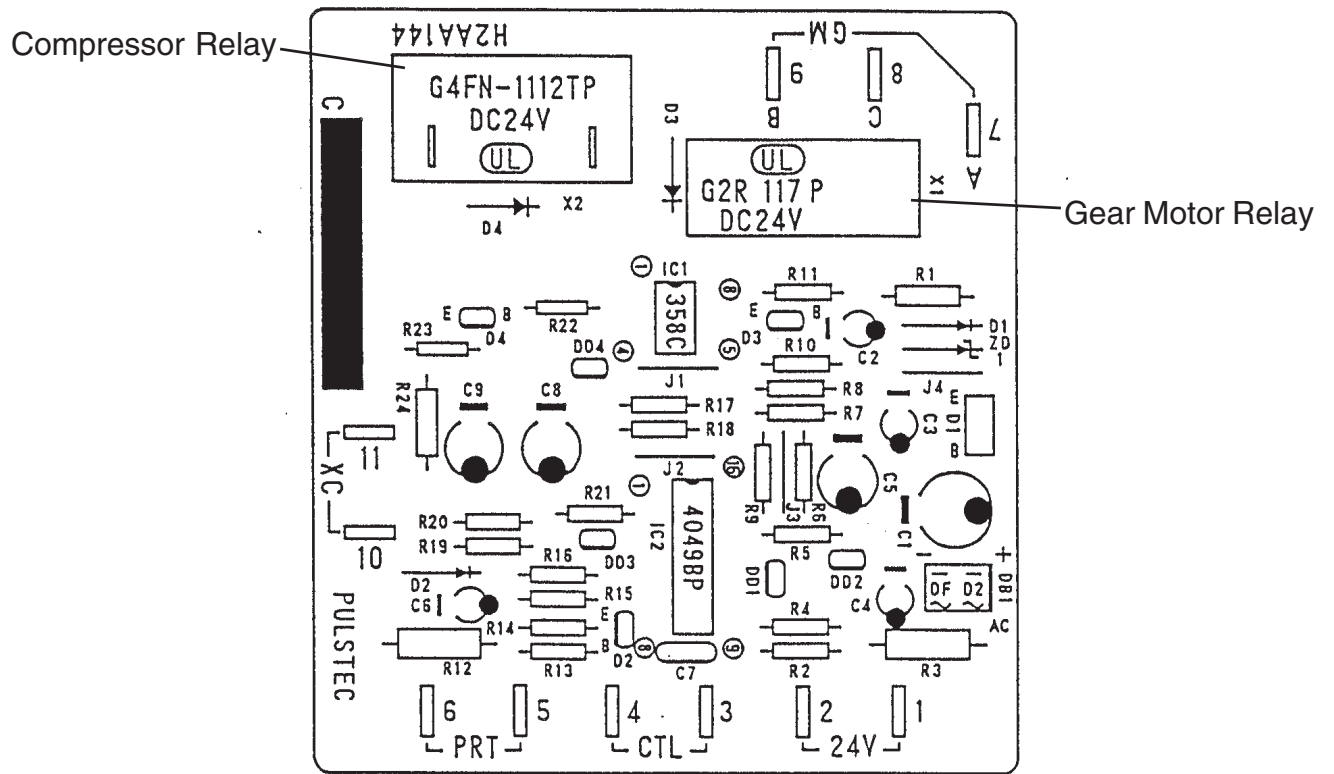

Fig. 1

[c] Sequence

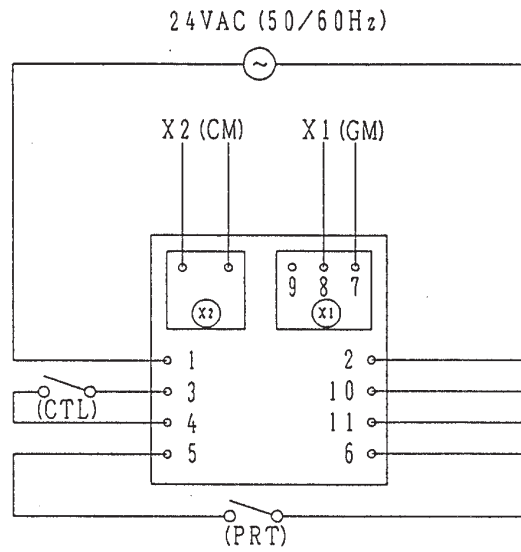
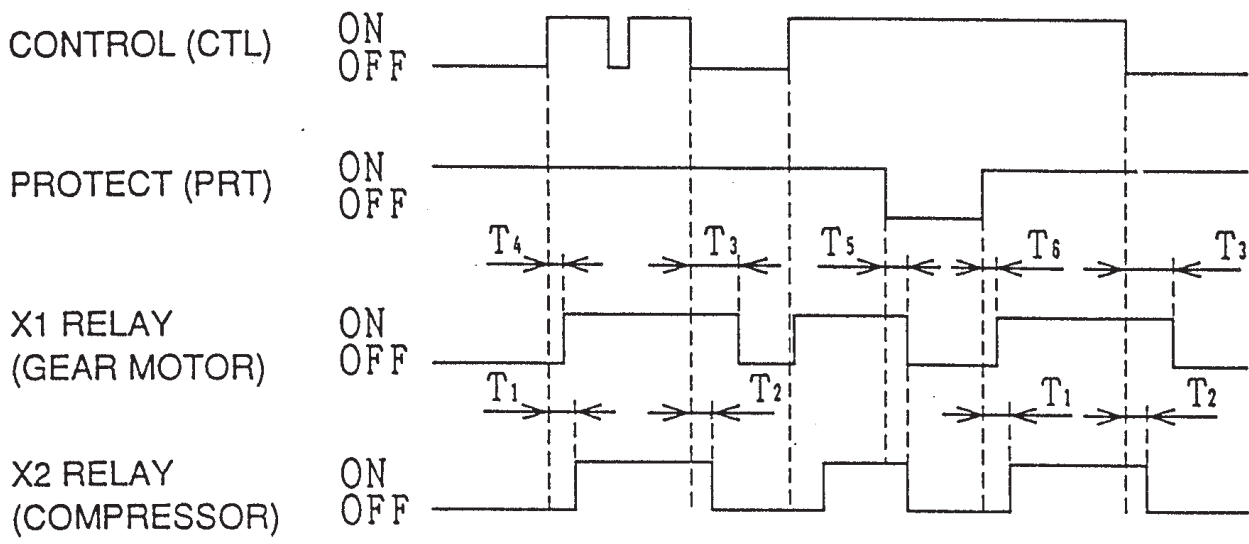

Fig. 2



PART CODE	437305-01
MODEL	H2AA144C01
RATING	24 VAC 50/60Hz
T1	60±15 sec.
T2	90±22 sec.
T3	150±45 sec.
T4	1 sec. or less
T5	6.7 sec. ± 70%
T6	6.7 sec. ± 70%

Fig. 3

Functions of Terminals

1) Terminals 1, 2

Power supply AC 24V.

2) Terminals 3, 4

Control X1 (GM) and X2 (CM) Relays.

When closed, energize X1 (GM) in 1 sec. and X2 (CM) in 60 sec.

When opened, de-energize X1 (GM) in 150 sec. and X2 (CM) in 90 sec.

3) Terminals 5, 6

Control X1 (GM) and X2 (CM) Relays.

When opened, de-energize X1 (GM) and X2 (CM) immediately.

When closed again, energize X1 (GM) in 1 sec. and X2 (CM) in 60 sec.

4) Terminals 7, 8, 9

X1 (GM) contacts.

8 is a movable contact, 7 is a make contact, and 9 is a break contact.

5) Terminals 10, 11

Control X2 (CM) Relays.

When opened, de-energize X2 (CM) immediately.

When closed, energize X2 (CM) immediately.

Note: 1. X2 Relay is a single pole, normally open relay, and its terminals are mounted on the relay itself.

2. The above operation times are median. See Fig. 3 for details.

III. Technical Information

1. Water Circuit and Refrigerant Circuit

F-500BAF, F-500BAF-C

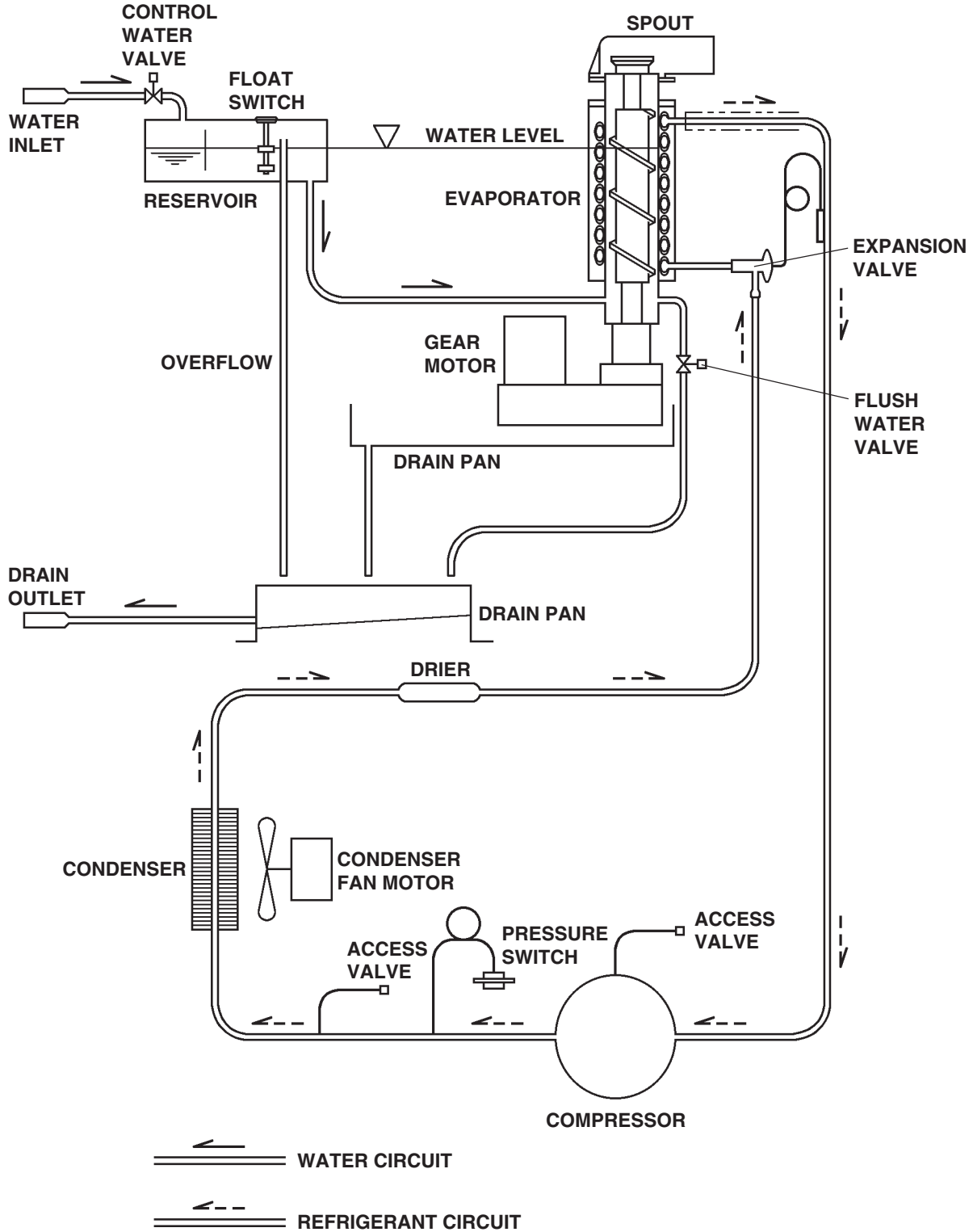

3. Sequence of Electrical Circuit

F-500BAF, F-500BAF-C

[a] When power switch is moved to "ON" position and flush switch to "ICE" position, water starts to be supplied to reservoir.

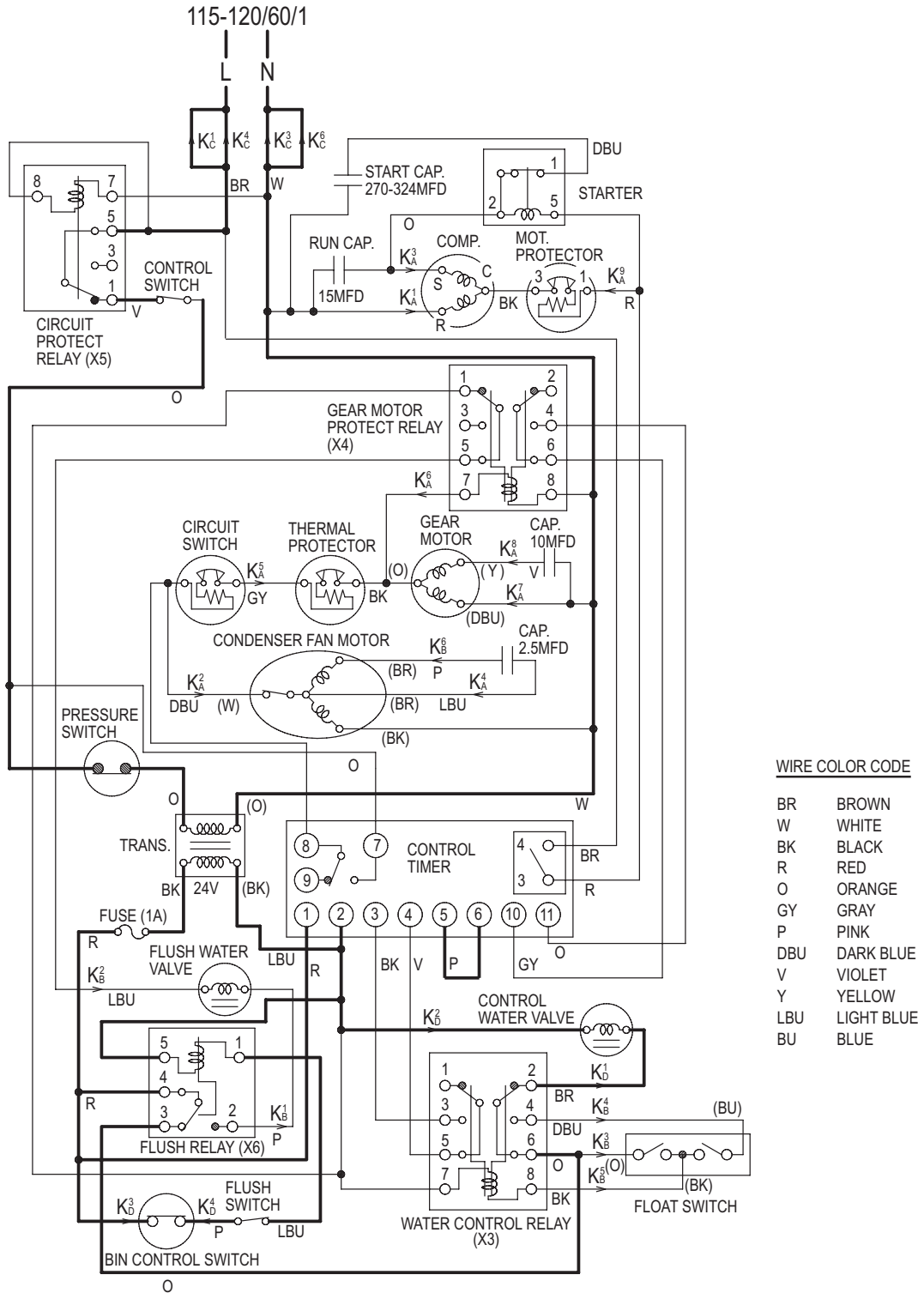

WIRE COLOR CODE

BR	BROWN
W	WHITE
BK	BLACK
R	RED
O	ORANGE
GY	GRAY
P	PINK
DBU	DARK BLUE
V	VIOLET
Y	YELLOW
LBU	LIGHT BLUE
BU	BLUE

(F-500BAF(-C))

[b] When reservoir has been filled up, gear motor starts immediately.

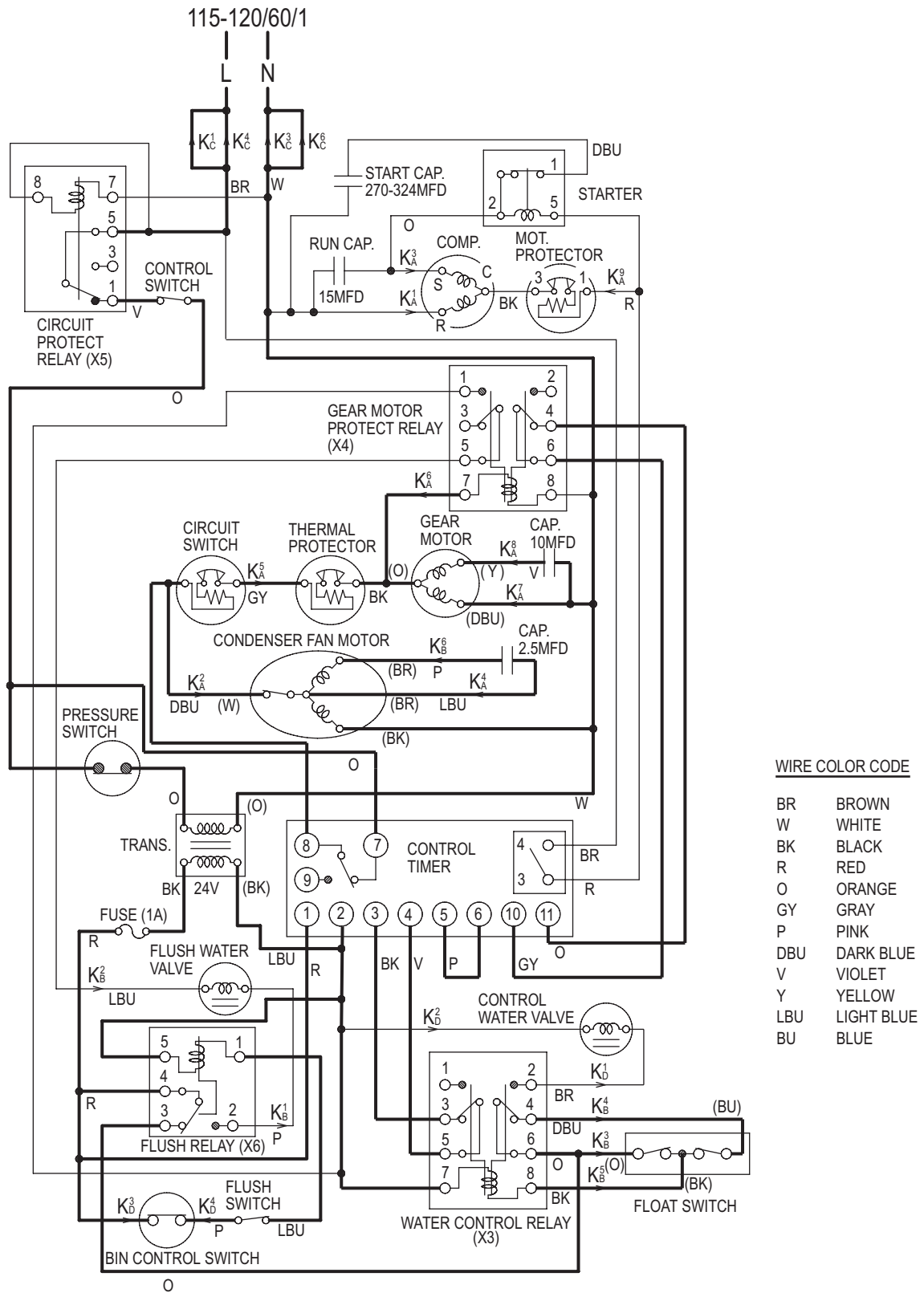

(F-500BAF(-C))

[c] Compressor starts about 60 sec. after gear motor starts.

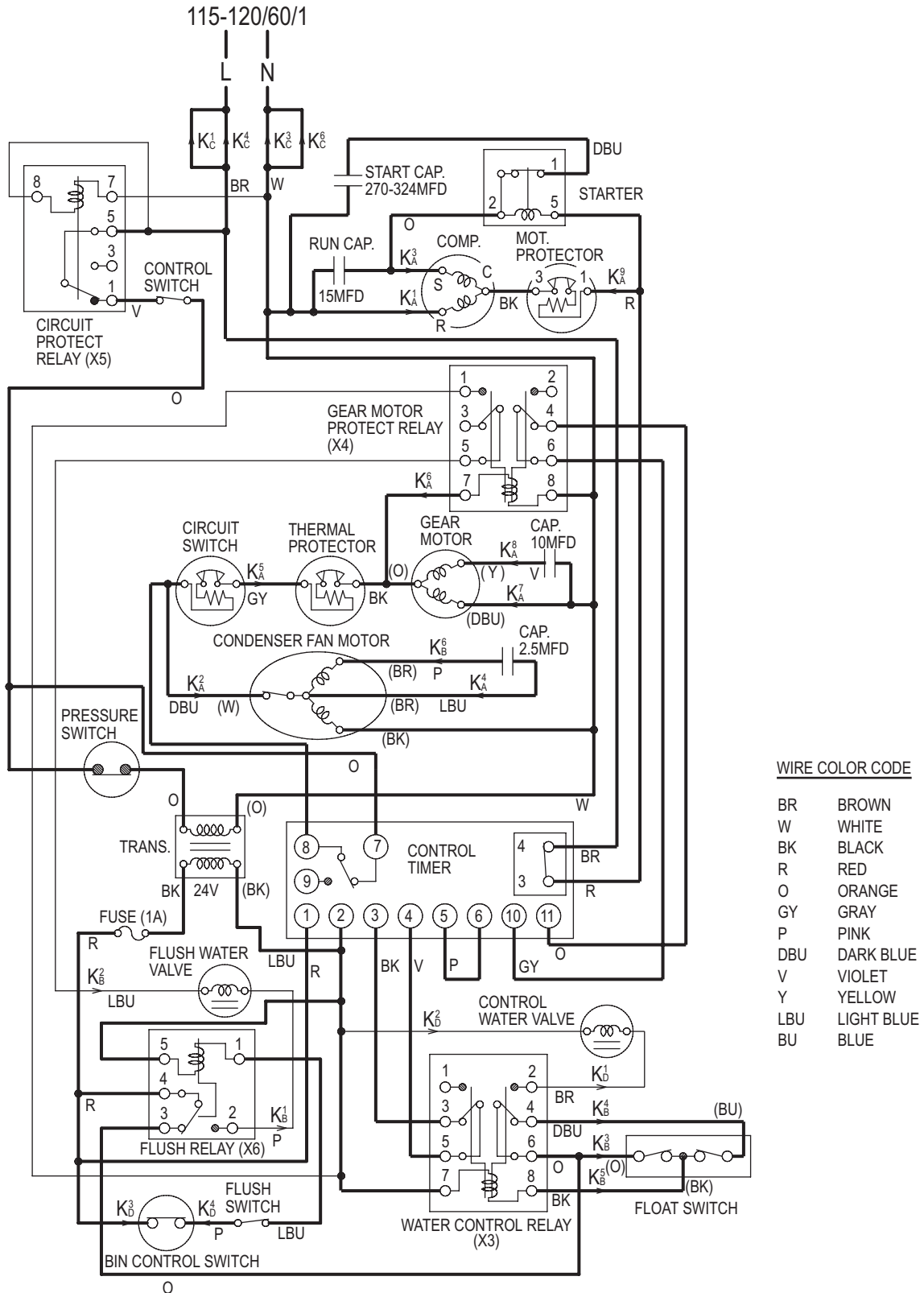

(F-500BAF(-C))

[d] Compressor stops about 90 sec. after bin control operates. Gear motor stops about 60 sec. later, and water is drained from the water circuit. Water can be also drained by moving flush switch to "FLUSH" position.

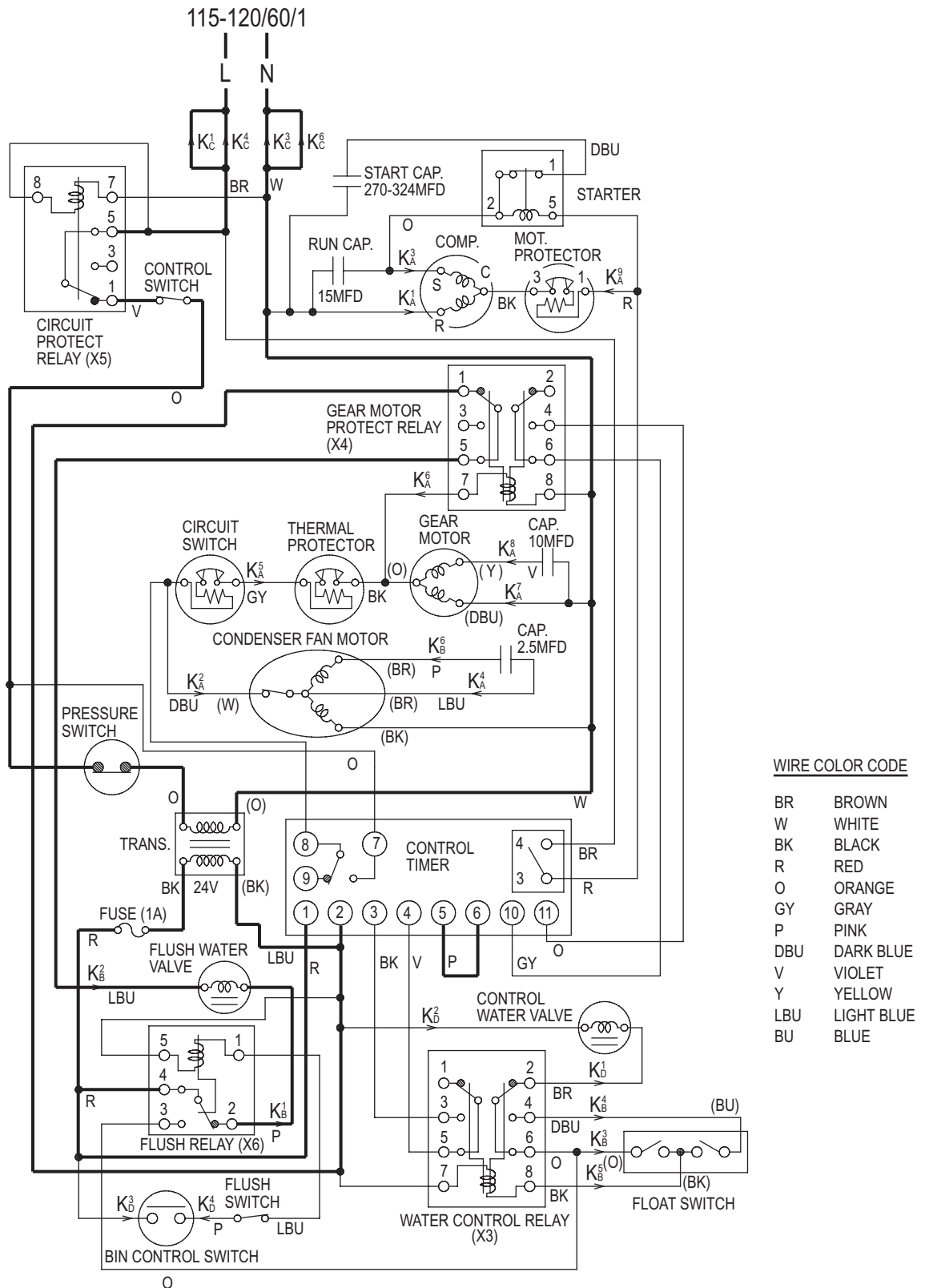

(F-500BAF(-C))

[e] When 208 - 230V are supplied to the power supply due to miswiring, circuit protect relay operates, and the icemaker does not run.

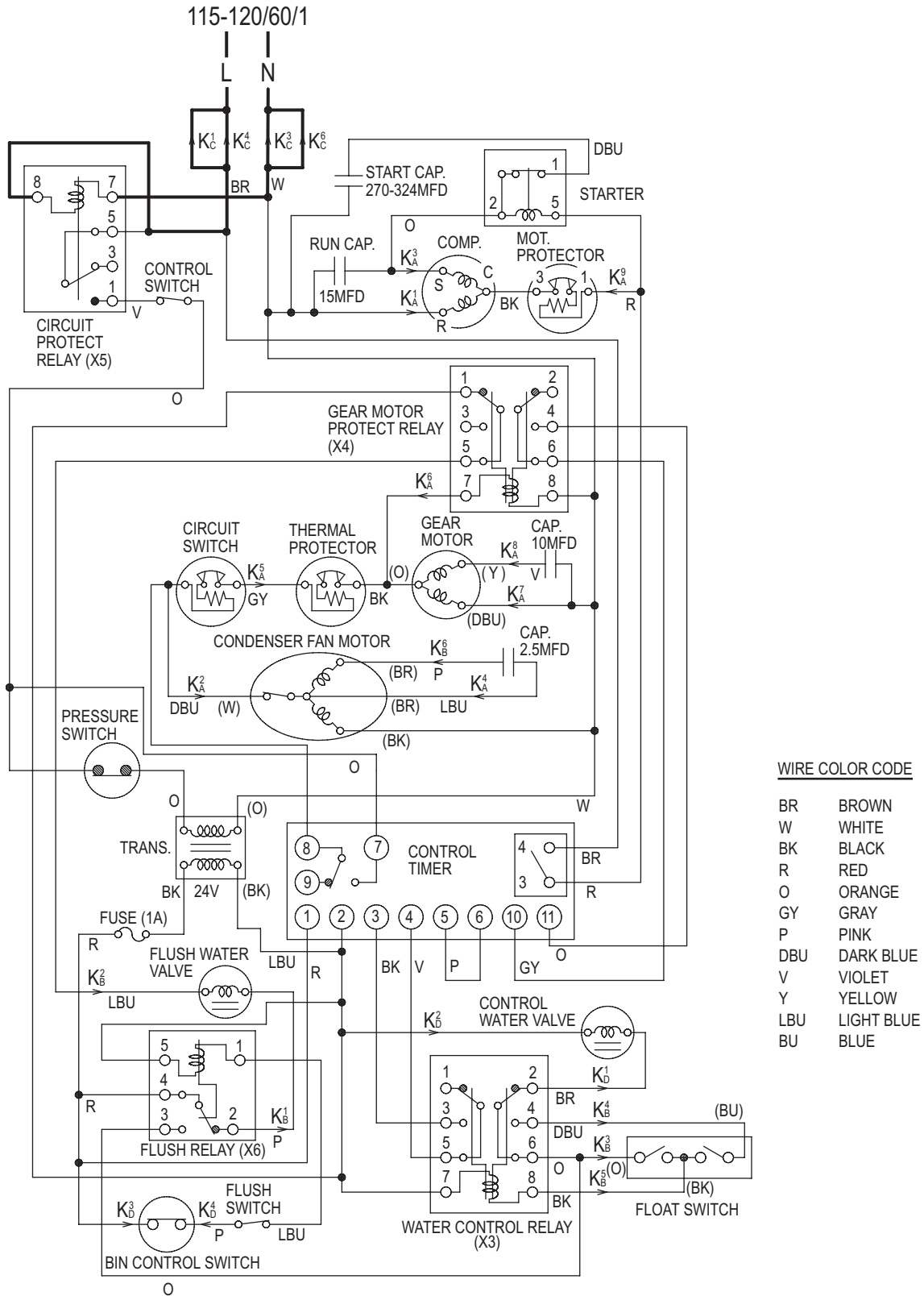

(F-500BAF(-C))

4. Timing Chart

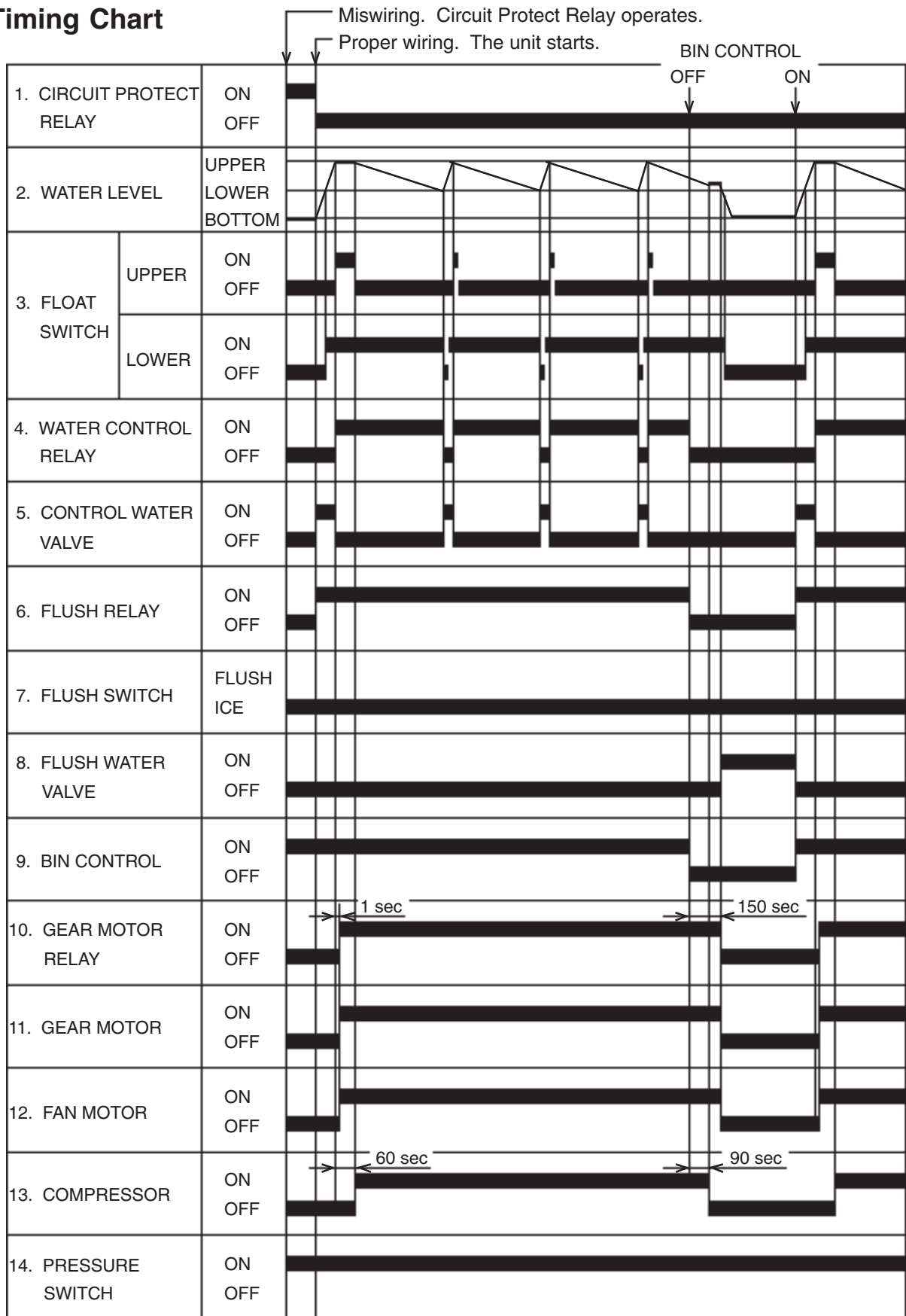

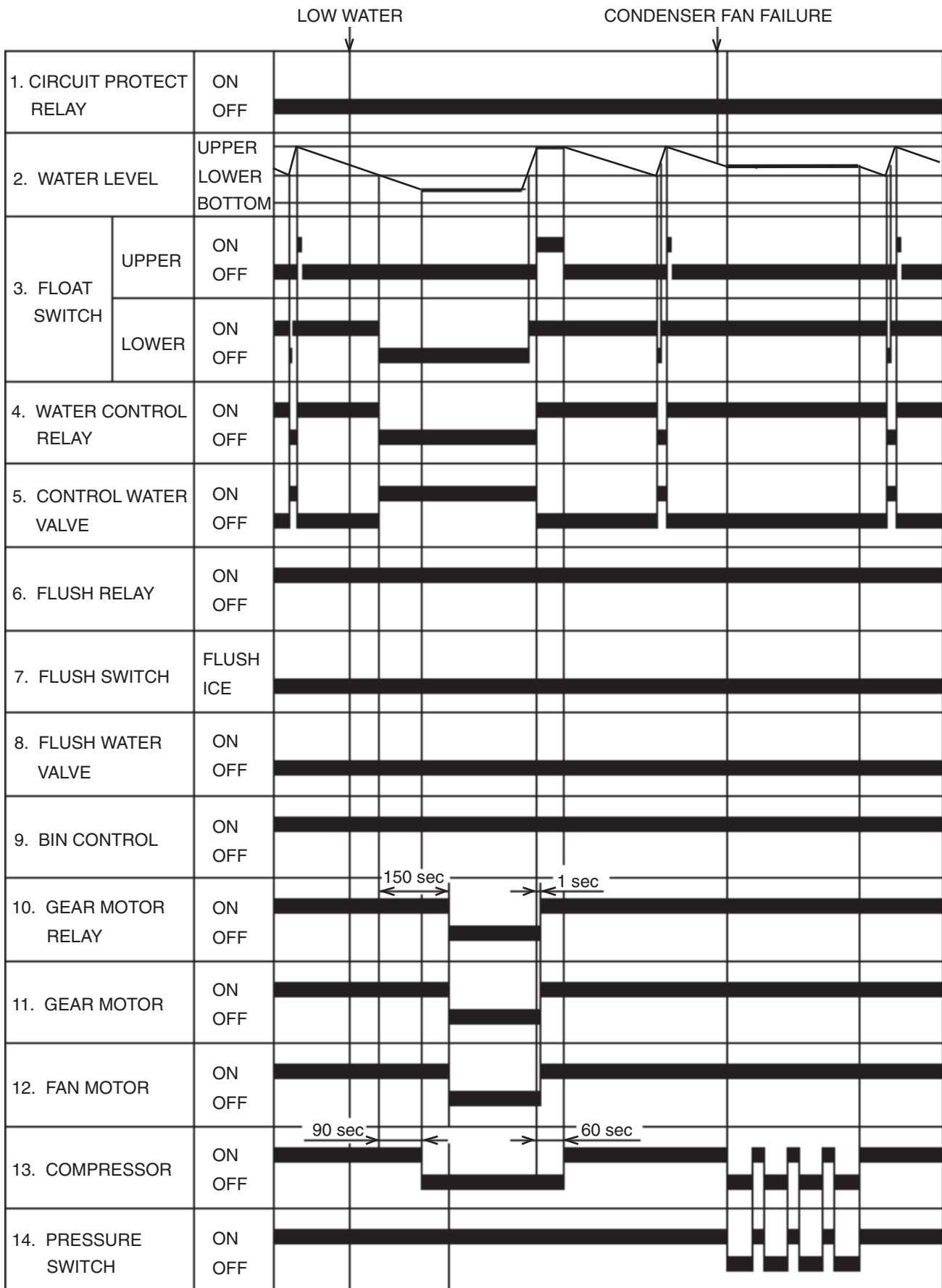

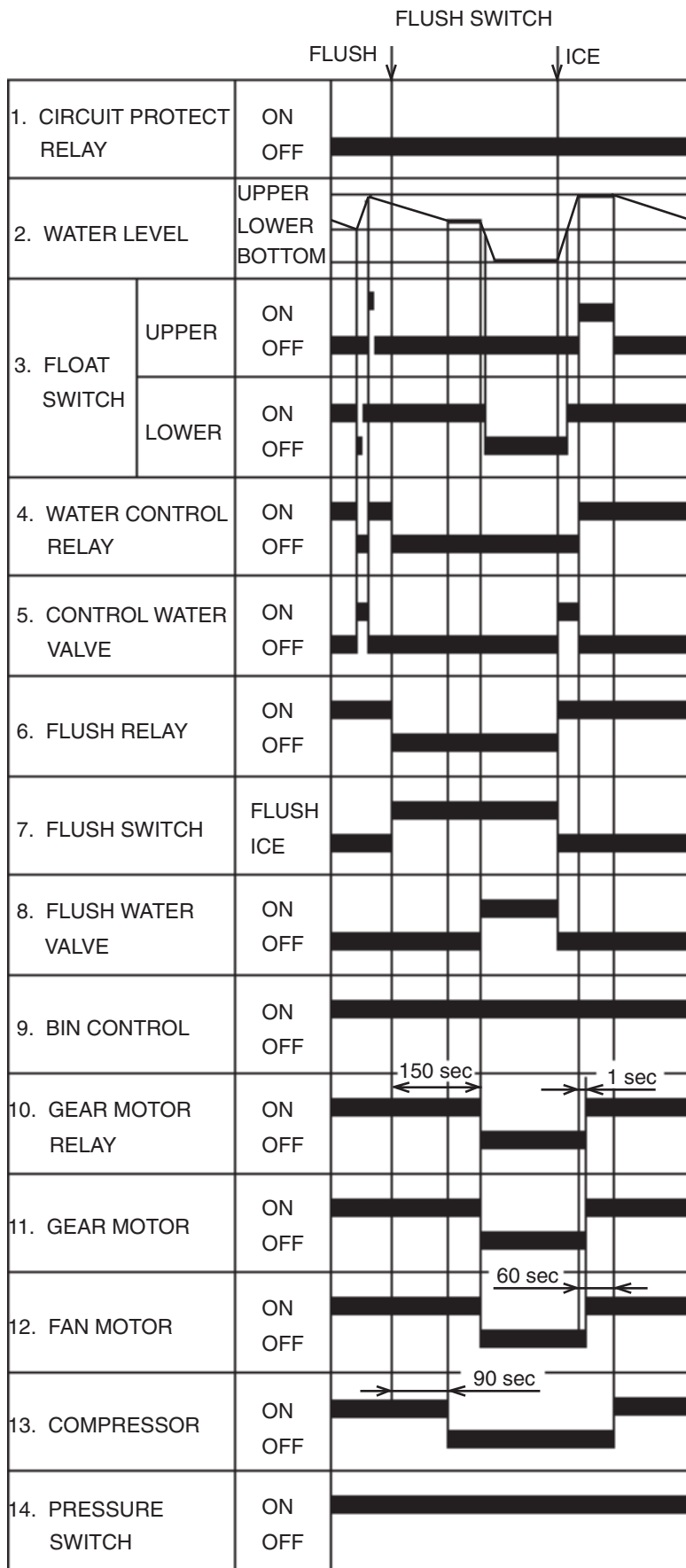

5. Performance Data

F-500BAF

APPROXIMATE ICE PRODUCTION PER 24 HR.	Ambient Temp. (°F)	Water Temp. (°F)					
		50		70		90	
lbs./day (kg/day)	70	*478	*(217)	458	(208)	438	(199)
	80	419	(190)	400	(182)	383	(174)
	90	366	(166)	*359	*(163)	335	(152)
	100	320	(145)	306	(139)	*287	*(130)
APPROXIMATE ELECTRIC CONSUMPTION	70	*854	--	861	--	867	--
	80	874	--	880	--	887	--
	90	893	--	*900	--	908	--
	100	915	--	923	--	*930	--
APPROXIMATE WATER CONSUMPTION PER 24 HR.	70	*57	*(217)	55	(208)	53	(199)
	80	50	(190)	48	(182)	46	(174)
	90	44	(166)	*43	*(163)	40	(152)
	100	38	(145)	37	(139)	*34	*(129)
EVAPORATOR OUTLET TEMP.	70	*8	*(-13)	8	(-13)	8	(-13)
	80	8	(-13)	12	(-11)	12	(-11)
	90	12	(-11)	*11	*(-11)	15	(-9)
	100	15	(-9)	15	(-9)	*15	*(-9)
HEAD PRESSURE	70	*221	*(15.5)	221	(15.6)	221	(15.5)
	80	253	(17.8)	253	(17.8)	253	(17.8)
	90	285	(20)	*285	*(20)	285	(20)
	100	327	(23)	327	(23)	*327	*(23)
SUCTION PRESSURE	70	*26	*(1.8)	26	(1.8)	26	(1.8)
	80	28	(2.0)	28	(2.0)	28	(2.0)
	90	31	(2.1)	*31	*(2.0)	31	(2.1)
	100	34	(2.4)	34	(2.4)	*34	*(2.4)
TOTAL HEAT OF REJECTION	4683 BTU/h (AT 90°F /WT 70°F)						

Note: The data without *marks should be used for reference.

We reserve the right to make changes in specifications and design without prior notice.

F-500BAF-C

APPROXIMATE ICE PRODUCTION PER 24 HR.	Ambient Temp. (°F)	Water Temp. (°F)					
		50		70		90	
	70	*431	*(196)	415	(188)	398	(181)
	80	381	(173)	365	(166)	350	(159)
	90	336	(152)	*333	*(151)	308	(140)
lbs./day (kg/day)	100	295	(134)	283	(128)	*263	*(119)
APPROXIMATE ELECTRIC CONSUMPTION	70	*864	--	869	--	875	--
	80	880	--	886	--	891	--
	90	897	--	*902	--	907	--
	100	912	--	917	--	*922	--
APPROXIMATE WATER CONSUMPTION PER 24 HR.	70	*52	*(196)	50	(188)	48	(181)
	80	46	(173)	44	(166)	42	(159)
	90	40	(152)	*40	*(151)	37	(140)
	gal./day (l/day)	100	35	(134)	34	(128)	*32
EVAPORATOR OUTLET TEMP.	70	*9	*(-13)	9	(-13)	9	(-13)
	80	9	(-13)	12	(-11)	12	(-11)
	90	12	(-11)	*12	*(-11)	15	(-9)
	°F (°C)	100	15	(-9)	15	(-9)	*15
HEAD PRESSURE	70	*225	*(15.8)	225	(15.8)	225	(15.8)
	80	258	(18.1)	258	(18.1)	258	(18.1)
	90	292	(20.5)	*292	*(20.5)	292	(20.5)
	PSIG (kg/cm ² G)	100	332	(23.3)	332	(23.3)	*332
SUCTION PRESSURE	70	*27	*(1.9)	27	(1.9)	27	(1.9)
	80	30	(2.1)	30	(2.1)	30	(2.1)
	90	32	(2.3)	*32	*(2.3)	32	(2.3)
	PSIG (kg/cm ² G)	100	35	(2.5)	35	(2.5)	*35
TOTAL HEAT OF REJECTION		4724 BTU/h (AT 90°F /WT 70°F)					

Note: The data without *marks should be used for reference.

We reserve the right to make changes in specifications and design without prior notice.

IV. Service Diagnosis

1. No Ice Production

PROBLEM	POSSIBLE CAUSE		REMEDY
[1] The icemaker will not start.	a) Power Supply	1. OFF position.	1. Move to ON position.
		2. Loose connection.	2. Tighten.
		3. Bad contacts.	3. Check for continuity and replace.
		4. Blown fuse.	4. Replace.
	b) Power Switch (Control Box)	1. Off position.	1. Move to ON position.
		2. Bad contacts.	2. Check for continuity and replace.
	c) Fuse (Control Box)	1. Blown out.	1. Check for short circuit and replace.
	d) Circuit Protect Relay	1. Miswiring.	1. Check power supply voltage and wire properly.
	e) Flush Switch	1. FLUSH position.	1. Move to ICE position.
		2. Bad contacts.	2. Check for continuity and replace.
	f) Transformer	1. Coil winding opened.	1. Replace.
g) Control Water Valve	1. Coil winding opened.	1. Replace.	
h) Shut-off Valve	1. Closed.	1. Open.	
	2. Water failure.	2. Wait till water is supplied.	
i) Plug and Receptacle (Control Box)	1. Disconnected.	1. Connect.	
	2. Terminal out of Plug or Receptacle.	2. Insert terminal back in position	
[2] Water does not stop, and the icemaker will not start	a) Water Control Relay	1. Contact fused.	1. Replace.
		2. Coil winding opened.	2. Replace.
	b) Float Switch	1. Bad contacts.	1. Check for continuity and replace.
		2. Float does not move freely.	2. Clean or replace.
	c) Flush Water Valve	1. Valve seat clogged and water leaking.	1. Clean or replace
d) Hoses	1. Disconnected.	1. Connect.	
[3] Water has been supplied, but the icemaker will not start.	a) Water Control Relay	1. Bad contacts.	Check for continuity and replace.
	b) Bin Control	1. Bad contacts.	Check for continuity and replace.
		2. Activator does not move freely.	Clean axle and its corresponding holes or replace Bin Control.
c) Gear Motor Protector (Circuit Breaker)	1. Tripped.	1. Find out the cause, get rid of it, and press Reset Button on Circuit Breaker.	

PROBLEM	POSSIBLE CAUSE		REMEDY
	d) Gear Motor Protect Relay	1. Coil winding opened. 2. Bad contacts.	1. Replace. 2. Check for continuity and replace.
	e) Control Timer (Printed Circuit Board)	1. Broken.	1. Replace.
[4] Gear Motor starts, but Compressor will not start or operates intermittently	a) Pressure Switch	1. Dirty Air Filter or Condenser.	1. Clean.
		2. Ambient temperature too warm.	2. Get cooler.
		3. Fan not rotating.	3. See "3. [1] a) Fan Motor."
		4. Refrigerant overcharged.	4. Recharge.
		5. Refrigerant line or components plugged.	5. Clean and replace drier.
		6. Bad contacts.	6. Check for continuity and replace.
		7. Loose connections.	7. Tighten.
	b) X2 Relay on Control Timer	1. Bad contacts.	1. Check for continuity and replace.
	c) Starter	2. Coil winding opened.	2. Replace Timer.
		1. Bad contacts.	1. Check for continuity and replace.
		2. Coil winding opened.	2. Replace.
	d) Start Capacitor or Run Capacitor	3. Loose Connections.	3. Tighten.
		1. Defective.	1. Replace.

PROBLEM	POSSIBLE CAUSE		REMEDY
	e) Compressor	1. Loose connections.	1. Tighten.
		2. Motor winding opened or grounded.	2. Replace.
		3. Motor Protector tripped.	3. Find out the cause of overheat or overcurrent.
	f) Power Supply	1. Circuit Ampacity too low.	1. Install a larger-sized conductor.
[5] Gear Motor and Compressor start but no ice is produced.	a) Refrigerant Line	1. Gas leaks.	1. Check for leaks with a leak detector. Reweld leak, replace drier and charge with refrigerant. The amount of refrigerant is marked on Nameplate or Label.
		2. Refrigerant line clogged.	2. Replace the clogged component.

2. Low Ice Production

PROBLEM	POSSIBLE CAUSE		REMEDY
[1] Low ice production	a) Refrigerant Line	1. Gas leaks.	1. See "1. [5] a) Refrigerant Line."
		2. Refrigerant line clogged.	2. Replace the clogged component.
		3. Overcharged.	3. Recharge.
	b) High-side Pressure Too High	1. Dirty Air Filter or Condenser.	1. Clean.
		2. Ambient temperature too warm.	2. Get cooler.
		3. Fan rotating too slow.	3. See "3 [1] a) Fan Motor."
	c) Expansion Valve (not adjustable)	1. Low-side pressure too low.	1. Replace.
		2. Low-side pressure too high.	2. See if Expansion Valve Bulb is mounted properly, and replace the valve if necessary.

3. Other

PROBLEM	POSSIBLE CAUSE		REMEDY
[1] Abnormal noise	a) Fan Motor	1. Bearing worn out.	1. Replace.
		2. Fan blade deformed.	2. Replace fan blade.
		3. Fan blade does not move freely.	3. Replace.
	b) Compressor	1. Bearings worn out, or cylinder valve broken.	1. Replace.
		2. Mounting pad out of position.	2. Reinstall.
	c) Refrigerant Lines	1. Rub or touch lines or other surfaces.	1. Replace.
	d) Gear Motor (Ice Making)	1. Bearing or Gear worn out / damaged.	1. Replace.
e) Evaporator	1. Low-side pressure too low.	1. See if Expansion Valve Bulb is mounted properly, and replace the valve if necessary.	
	2. Scale on inside wall of Freezing Cylinder.	2. Remove Auger. Use "SCALE AWAY" or "LIME-A-WAY" solution to clean periodically. If the water is found hard by testing, install a softener.	
[2] Overflow from Reservoir (Water does not stop.)	a) Water Supply	1. Water pressure too high.	1. Install a pressure Reducing Valve
	b) Control Water Valve	1. Diaphragm does not close.	1. Clean or replace.
	c) Float Switch	1. Bad contacts.	1. Check for continuity and replace.
[3] Gear Motor Fuse blows or Circuit Breaker trips frequently.	a) Power Supply Voltage	1. Too high or too low.	1. Connect the unit to a power supply of proper voltage.
	b) Evaporator Assy	1. Bearings or Auger worn out.	1. Replace Bearing or Auger.
	c) Bin Control	1. Bad contacts.	1. Check for continuity and replace.
		2. Activator does not move freely.	2. Clean Axle and its corresponding holes or replace Bin Control.

V. Removal and Replacement of Components

IMPORTANT

Ensure all components, fasteners and thumbscrews are securely in place after the equipment is serviced.

IMPORTANT

1. The Polyol Ester (POE) oils used in R-404A units can absorb moisture quickly. Therefore it is important to prevent moisture from entering the system when replacing or servicing parts.
2. Always install a new filter drier every time the sealed refrigeration system is opened.
3. Do not leave the system open for longer than 15 minutes when replacing or servicing parts.

1. Service for Refrigerant Lines

[a] Refrigerant Recovery

The icemaker unit is provided with two refrigerant access valves - one on the low-side and one on the high-side line. Using proper refrigerant practices recover the refrigerant from the access valves and store it in an approved container. Do not discharge the refrigerant into the atmosphere.

[b] Evacuation and Recharge [R-404A]

- 1) Attach charging hoses, a service manifold and a vacuum pump to the system. Be sure to connect charging hoses to both high-side and low-side access valves.

IMPORTANT

The vacuum level and vacuum pump may be the same as those for current refrigerants. However, the rubber hose and gauge manifold to be used for evacuation and refrigerant charge should be exclusively for POE oils.

- 2) Turn on the vacuum pump. Never allow the oil in the vacuum pump to flow backward.
- 3) Allow the vacuum pump to pull down to a 29.9" Hg vacuum. Evacuating period depends on pump capacity.
- 4) Close the low-side valve and high-side valve on the service manifold.

- 5) Disconnect the vacuum pump, and attach a refrigerant service cylinder to the high-side line. Remember to loosen the connection, and purge the air from the hose. See the nameplate for the required refrigerant charge. Hoshizaki recommends only virgin refrigerant or reclaimed refrigerant which meets ARI Standard No. 700-88 be used.
- 6) A liquid charge is recommended for charging an R-404A system. Invert the service cylinder. Open the high-side, service manifold valve.
- 7) Allow the system to charge with liquid until the pressures balance.
- 8) If necessary, add any remaining charge to the system through the low-side. Use a throttling valve or liquid dispensing device to add the remaining liquid charge through the low-side access port with the unit running.
- 9) Close the two refrigerant access valves, and disconnect the hoses and service manifold.
- 10) Cap the access valves to prevent a possible leak.

2. Brazing

WARNING

1. Refrigerant R-404A itself is not flammable at atmospheric pressure and temperatures up to 176°F.
2. Refrigerant R-404A itself is not explosive or poisonous. However, when exposed to high temperatures (open flames) R-404A can be decomposed to form hydrofluoric acid and carbonyl fluoride both of which are hazardous.
3. Always recover the refrigerant and store it in an approved container. Do not discharge the refrigerant into the atmosphere.
4. Do not use silver alloy or copper alloy containing arsenic.
5. Do not use R-404A as a mixture with pressurized air for leak testing. Refrigerant leaks can be detected by charging the unit with a little refrigerant, raising the pressure with nitrogen and using an electronic leak detector.

Note: All brazing-connections are clear-paint coated. Sandpaper the brazing-connections before unbrazing the components. Use a good abrasive cloth to remove coating.

3. Removal and Replacement of Compressor

IMPORTANT

Always install a new drier every time the sealed refrigeration system is opened. Do not replace the drier until after all other repair or replacement has been made.

- 1) Unplug the icemaker.
- 2) Remove the panels.
- 2) Remove the terminal cover on the compressor, and disconnect the compressor wiring.
- 3) Recover the refrigerant and store it in an approved container, if required by an applicable law.
- 4) Remove the discharge, suction, and access pipes from the compressor using brazing equipment.

WARNING

When repairing a refrigerant system, be careful not to let the burner flame contact any electrical wires or insulation.

- 5) Remove the bolts and rubber grommets.
- 6) Slide and remove the compressor. Unpack the new compressor package. Install the new compressor.
- 7) Attach the rubber grommets of the prior compressor.
- 8) Sandpaper the discharge, suction and access pipes.
- 9) Place the compressor in position, and secure it using the bolts.
- 10) Remove plugs from the discharge, suction and access pipes.
- 11) Braze the access, suction and discharge lines (Do not change this order), while purging with nitrogen gas flowing at the pressure of 3-4 PSIG.
- 12) Install the new drier.

- 13) Check for leaks using nitrogen gas (140 PSIG) and soap bubbles.
- 14) Evacuate the system, and charge it with refrigerant. See the nameplate for the required refrigerant charge and type.
- 15) Connect the terminals to the compressor, and replace the terminal cover in its correct position.
- 16) Replace the panels in their correct position.
- 17) Plug in the icemaker.

4. Removal and Replacement of Drier

IMPORTANT

Always install a new drier every time the sealed refrigeration system is opened. Do not replace the drier until after all other repair or replacement has been made.

- 1) Unplug the icemaker.
- 2) Remove the panels.
- 3) Recover the refrigerant and store it in an approved container, if required by an applicable law.
- 4) Remove the drier using brazing equipment.
- 5) Install the new drier with the arrow on the drier in the direction of the refrigerant flow. Use nitrogen gas at the pressure of 3-4 PSIG when brazing the tubings.
- 6) Check for leaks using nitrogen gas (140 PSIG) and soap bubbles.
- 7) Evacuate the system, and charge it with refrigerant. See the nameplate for the required refrigerant charge and type.
- 8) Replace the panels in their correct position.
- 9) Plug in the icemaker.

5. Removal and Replacement of Expansion Valve

IMPORTANT

Sometimes moisture in the refrigerant circuit exceeds the drier capacity and freezes up at the expansion valve. Always install a new drier every time the sealed refrigeration system is opened. Do not replace the drier until after all other repairs or replacement have been made.

- 1) Unplug the icemaker.
- 2) Remove the panels.
- 3) Recover the refrigerant and store it in an approved container, if required by an applicable law.
- 4) Remove the expansion valve bulb at the evaporator outlet.
- 5) Remove the expansion valve cover, and remove the expansion valve using brazing equipment.
- 6) Braze the new expansion valve with nitrogen gas flowing at the pressure of 3-4 PSIG.

WARNING

Always protect the valve body by using a damp cloth to prevent the valve from overheating. Do not braze with the valve body exceeding 250°F.

- 7) Install the new drier.
- 8) Check for leaks using nitrogen gas (140 PSIG) and soap bubbles.
- 9) Evacuate the system. Charge it with refrigerant. See the nameplate for the required refrigerant charge and type.
- 10) Attach the bulb to the suction line. Be sure to secure the bulb using a band and to insulate it.
- 11) Place the expansion valve cover in position.
- 12) Replace the panels in their correct position.
- 13) Plug in the icemaker.

6. Removal and Replacement of Evaporator Assembly

- 1) Drain the water from the evaporator by switching the flush switch to “FLUSH” on the control box.
- 2) Unplug the icemaker.
- 3) Remove the panels.
- 4) Remove the three thumbscrews and take off the spout from the evaporator.

Cutter

- 5) Loosen the cutter by a wrench and remove it.
- 6) Remove the cylinder gasket at the top of the evaporator.

Extruding Head

- 7) Grasp the top of the auger and move the auger towards you and then try to insert a .02" round stock or pin gauge in between the back side of the auger shaft and the bearing surface. Check several locations around the auger shaft. If the gauge goes between the shaft and the bearing at any point, both the top bearing in the extruding head and the lower bearing in the housing should be replaced. Instructions for removing the housing are located later in this procedure.

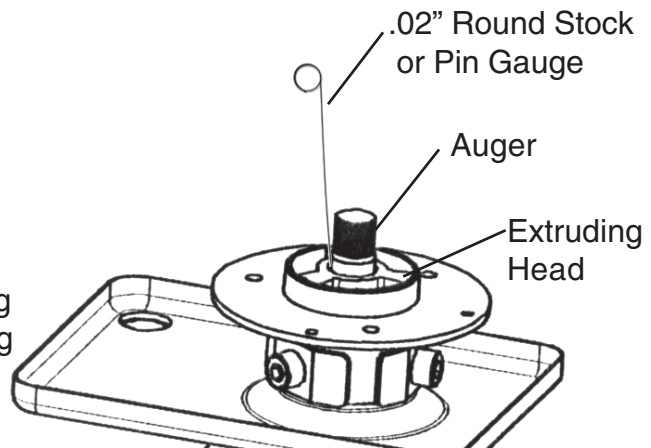

Note: Replacing the bearing requires a bearing press adaptor. If one is not available, replace the whole extruding head and housing.

- 8) Remove the three socket head cap screws and lift off the extruding head.

Auger

- 9) Lift out the auger. If the area in contact with the bearing is worn or the blade is scratched, replace the auger.

Evaporator

Note: Skip the following steps 10) through 12) when the evaporator does not need replacement.

- 10) Recover the refrigerant and store it in an approved container, if required by an applicable law.

IMPORTANT

Always install a new drier every time the sealed refrigeration system is opened. Do not replace the drier until after all other repair or replacement has been made.

- 11) Remove the bulb of the expansion valve.
- 12) Disconnect the brazing-connections of the expansion valve and the copper tube-low side from the evaporator, using brazing equipment.
- 13) Remove the two truss head machine screws and the bracket securing the evaporator.
- 14) Disconnect the three hoses from the evaporator.
- 15) Remove the four socket head cap screws securing the evaporator with the bearing-lower.
- 16) Lift off the evaporator.

Housing, Lower Bearing and Mechanical Seal

- 17) The mechanical seal consists of two parts. One moves along with the auger, and the other is fixed on the housing. If the contact surfaces of these two parts are worn or scratched, the mechanical seal may cause water leaks and should be replaced.
- 18) Remove the O-ring from the housing.
- 19) Remove the four bolts and the housing from the gear motor. If inspection of the bearing inside the extruding head (earlier in this procedure) indicated that it is out of tolerance, replace both it and the bearing inside the housing.

Note: Replacing the bearing requires a bearing press adaptor. If one is not available, replace the whole extruding head and housing.

Gear Motor

- 20) Remove the coupling-spline on the gear motor shaft.
- 21) Remove the three bolts securing the gear motor.
- 22) Assemble the removed parts in the reverse order of the above procedure.

WARNING

Be careful not to scratch the surface of the O-ring, or it may cause water leaks. Handle the mechanical seal with care not to scratch nor to contaminate its contact surface.

- 23) When replacing the evaporator:
 - (a) Braze the new evaporator with nitrogen gas flowing at the pressure of 3-4 PSIG.
 - (b) Replace the drier.
 - (c) Check for leaks using nitrogen gas (140 PSIG) and soap bubbles.
 - (d) Evacuate the system. Charge it with refrigerant. See the nameplate for required refrigerant charge and type.
- 24) Replace the panels in their correct position.
- 25) Plug in the icemaker.

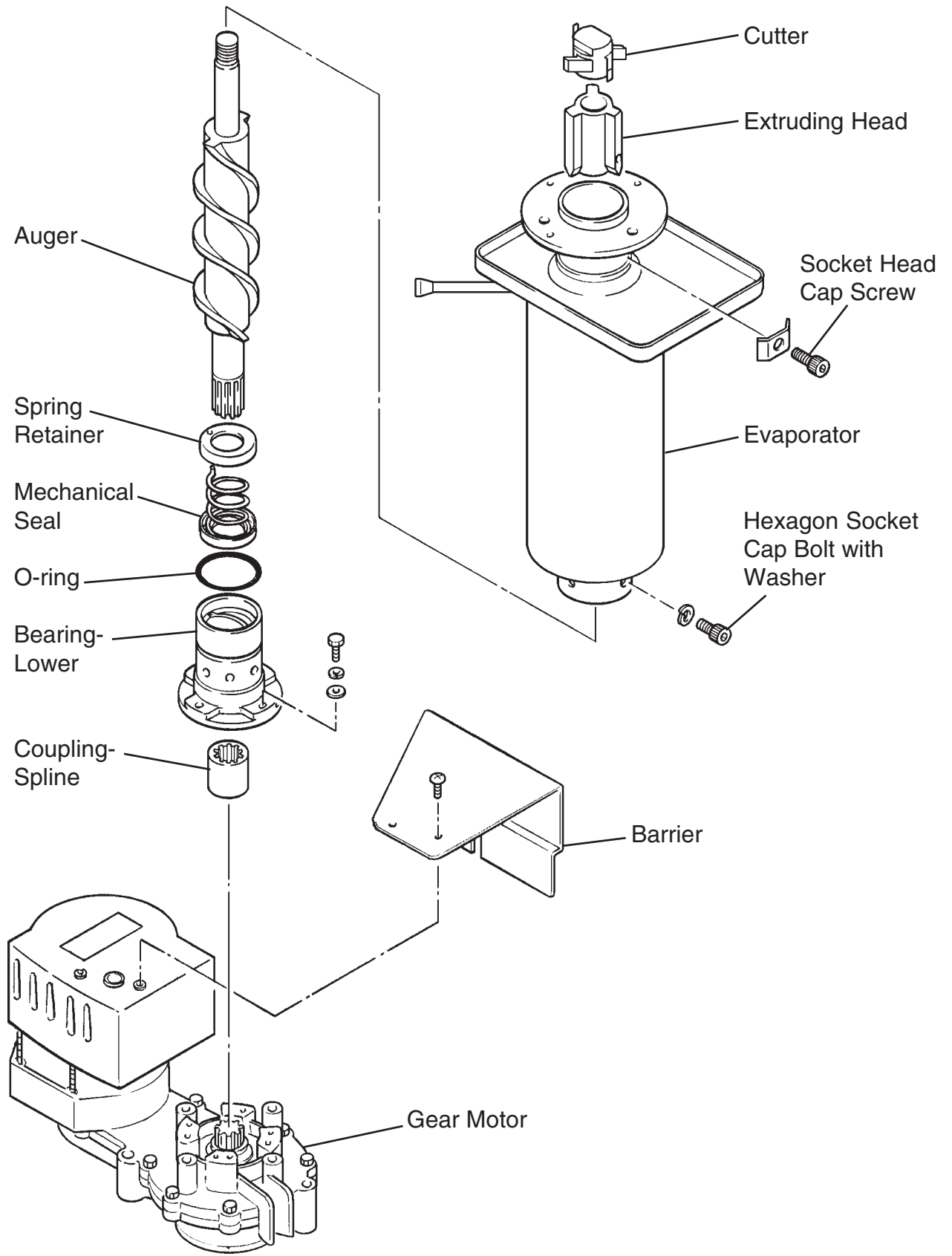

7. Removal and Replacement of Fan Motor

- 1) Unplug the icemaker.
- 2) Remove the panels.
- 3) Remove the wire connectors from the fan motor leads.
- 4) Remove the fan motor bracket and fan motor.
- 5) Install the new fan motor.
- 6) Replace the fan motor bracket and the wire connectors.
- 7) Replace the panels in their correct position
- 8) Plug in the icemaker.

8. Removal and Replacement of Control Water Valve

- 1) Unplug the icemaker.
- 2) Remove the panels.
- 3) Close the water supply line shut-off valve.
- 4) Disconnect the terminal from the control water valve.
- 5) Loosen the fitting nut on the control water valve inlets, and remove the control water valve. Do not lose the packings inside the fitting nut.
- 6) Remove the water supply hose from the control water valve.
- 7) Install the new control water valve.
- 8) Assemble the removed parts in the reverse order of the above procedure.
- 9) Open the water supply line shut-off valve.
- 10) Check for water leaks.
- 11) Replace the panels in their correct position.
- 12) Plug in the icemaker.

VI. Cleaning and Maintenance

IMPORTANT

Ensure all components, fasteners and thumbscrews are securely in place after any maintenance or cleaning is done to the equipment.

1. Preparing the Icemaker for Long Storage

WARNING

When shutting off the icemaker for an extended time, drain out all water from the water line and remove the ice from the storage bin. The storage bin should be cleaned and dried. Drain the icemaker to prevent damage to the water supply line at sub-freezing temperatures, using air or carbon dioxide. Shut off the icemaker until the proper ambient temperature is resumed.

- 1) Run the icemaker with the water supply line shut-off valve closed.
- 2) Open the drain valve and blow out the water inlet line by using air pressure.
- 3) Turn off the power supply.
- 4) Remove the front panel.
- 5) Move the flush switch on the control box to the "FLUSH" position.
- 6) Turn on the power supply, and then drain out all water from the water line.
- 7) Turn off the power supply.
- 8) Turn off the power switch on the control box.
- 9) Replace the front panel in its correct position.
- 10) Close the drain valve.
- 11) Remove all ice from the storage bin, and clean the bin.

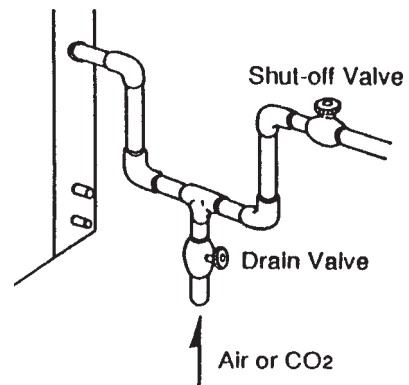

2. Cleaning and Sanitizing Instructions

WARNING

1. HOSHIZAKI recommends cleaning this unit at least once a year. More frequent cleaning, however, may be required in some existing water conditions.
2. To prevent injury to individuals and damage to the icemaker, do not use ammonia type cleaners.
3. Always wear liquid-proof gloves to prevent the cleaning and sanitizing solutions from coming into contact with skin.

[a] Cleaning Solution

Dilute 4.8 fl. oz. (142 ml) of recommended cleaner Hoshizaki “Scale Away” or “LIME-A-WAY” (Economics Laboratory, Inc.) with 0.8 gallons (3 l) of warm water. This is a minimum amount. Make more solution if necessary.

IMPORTANT

For safety and maximum effectiveness, use the solution immediately after dilution.

[b] Cleaning Procedure

- 1) Remove the front panel and the top panel, then turn off the power supply.
- 2) Close the water supply line shut-off valve.
- 3) Remove all ice from the storage bin.
- 4) Move the flush switch to the “FLUSH” position.
- 5) Turn on the power supply and drain out all water from the water line.
- 6) Turn off the power supply.
Note: This unit is designed to start operating when the reservoir is filled with water.

- 7) In the storage bin, remove the thumbscrews attaching spout (B), then remove spout (B) and spout packing (B).

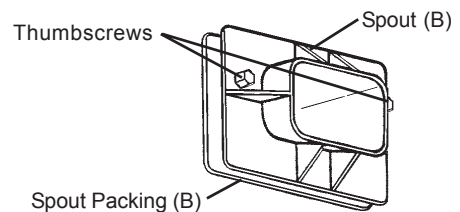

Fig. 4

- 8) Remove the thumbscrews attaching spout (A) to the evaporator assembly and lift off spout (A) and spout packing (A).
- 9) Pour the cleaning solution over the extruding head until the evaporator assembly and the reservoir are filled and the solution starts to overflow into the drain pan.
Note: If there is excess scale on the extruding head, fill the evaporator assembly and reservoir as described above, then use a clamp on the reservoir hose between the reservoir and evaporator assembly to block flow. Pour additional cleaning fluid over the extruding head until the evaporator assembly is completely full.
- 10) Using the thumbscrews, replace spouts (A) and (B) and spout packings (A) and (B) in their correct positions.
- 11) Allow the icemaker to sit for about 10 minutes before operation. If you placed a clamp on the reservoir hose in step 9, remove it before operation.
- 12) Move the flush switch to the "ICE" position, then turn on the power supply. Replace the top panel and the front panel in their correct positions. Make ice using the solution until the icemaker stops making ice.
- 13) Remove the front panel.
- 14) Move the flush switch to the "FLUSH" position to drain the remainder of the solution.
- 15) After the solution is drained, move the flush switch to the "ICE" position.
- 16) Replace the front panel in its correct position.
- 17) Open the water supply line shut-off valve, and supply water to the reservoir.
- 18) When the gear motor starts, remove the top panel and front panel. Turn off the power supply.
- 19) Drain out all water from the water line. See 4) through 6).

[c] Sanitizing Solution

Dilute 2.5 fl. oz. (74 ml or 5 tbs) of IMS-II Sanitizer or a 5.25% sodium hypochlorite solution (chlorine bleach) with 5 gallons (19 l) of warm water.

IMPORTANT

For safety and maximum effectiveness, use the solution immediately after dilution.

[d] Sanitizing Procedure - Initial

- 1) Close the water supply line shut-off valve.
- 2) In the storage bin, remove the thumbscrews attaching spout (B), then remove spout (B) and spout packing (B).
- 3) Remove the thumbscrews attaching spout (A) to the evaporator assembly and lift off spout (A) and spout packing (A), and the cylinder packing.
- 4) Pour the sanitizing solution over the extruding head until the evaporator assembly and the reservoir are filled and the solution starts to overflow into the drain pan.
- 5) Remove the thumbscrews attaching the bin control assembly to the inside of the bin top panel.
- 6) Remove the snap pin, shaft and actuator.
- 7) Remove the sliding door.
- 8) Soak the removed parts in .25 gallons (1 l) of sanitizing solution for 10 minutes then wipe them down.
- 9) Rinse the parts thoroughly.

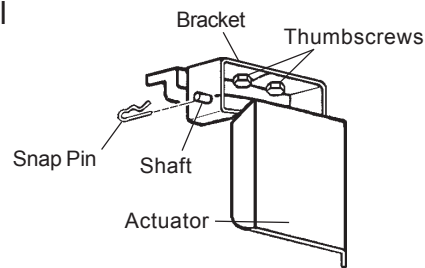

Fig. 5

IMPORTANT

If the solution is left on these parts, they will rust.

- 10) Replace all parts in their correct positions.
- 11) Move the flush switch to the “ICE” position, then turn on the power supply. Replace the top panel and the front panel in their correct positions. Make ice using the solution until the icemaker stops making ice.

[e] Sanitizing Procedure - Final

- 1) Remove the front panel and the top panel, then turn off the power supply.
- 2) Move the flush switch to the “FLUSH” position.
- 3) Turn on the power supply and drain out all water from the water line.
- 4) Turn off the power supply.
Note: This unit is designed to start operating when the reservoir is filled with water.
- 5) In the storage bin, remove the thumbscrews attaching spout (B), then remove spout (B) and spout packing (B).

- 6) Remove the thumbscrews attaching spout (A) to the evaporator assembly and lift off spout (A) and spout packing (A).
- 7) Pour the sanitizing solution over the extruding head until the evaporator assembly and the reservoir are filled and the solution starts to overflow into the drain pan.
- 8) Using the thumbscrews, replace spouts (A) and (B) and spout packings (A) and (B) in their correct positions.
- 9) Allow the icemaker to sit for about 10 minutes before operation.
- 10) Move the flush switch to the "ICE" position, then turn on the power supply. Replace the top panel and the front panel in their correct positions. Make ice using the solution until the icemaker stops making ice.
- 11) Remove the front panel.
- 12) Move the flush switch to the "FLUSH" position to drain the remainder of the solution.
- 13) After the solution is drained, move the flush switch to the "ICE" position.
- 14) Replace the front panel in its correct position.
- 15) Open the water supply line shut-off valve and supply water to the reservoir.
- 16) When the gear motor starts, remove the front panel and turn off the power supply.
- 17) Drain out all water from the water line. See 2) and 3).
- 18) Move the flush switch to the "ICE" position and run the icemaker.
- 19) Turn off the power supply after 30 minutes.
- 20) Pour warm water into the storage bin to melt all ice, then clean the bin liner with the solution.
- 21) Flush out any solution from the storage bin.
- 22) Turn on the power supply and start the automatic icemaking process.

IMPORTANT

1. After cleaning, do not use ice made from the sanitizing solution. Be careful not to leave any solution in the storage bin.
2. Follow carefully any instructions provided with the bottles of cleaning or sanitizing solution.
3. Never run the icemaker when the reservoir is empty.

3. Maintenance Instructions

IMPORTANT

1. This icemaker must be maintained individually, referring to the instruction manual and labels provided with the icemaker.
2. To have the optimum performance of this icemaker, the following consumable parts need periodic inspection, maintenance and replacement:

- Extruding Head
- Housing
- Gear Motor
- Auger
- Mechanical Seal

These parts should be inspected at least once a year or every 10,000 hours of operation. Their service life, however, depends on water quality and environment. More frequent inspection and maintenance are recommended.

Consult with your local distributor about inspection and maintenance service. To obtain the name and phone number of your local distributor, call Hoshizaki Technical Support at 1-800-233-1940 in the USA.

1) Stainless Steel Exterior

To prevent corrosion, wipe the exterior occasionally with a clean and soft cloth. Use a damp cloth containing a neutral cleaner to wipe off oil or dirt build up.

2) Storage Bin and Scoop

- Wash your hands before removing ice. Use the plastic scoop provided (bin accessory).
- The storage bin is for ice use only. Do not store anything else in the bin.
- Keep the scoop clean. Clean using a neutral cleaner and rinse thoroughly.
- Clean the bin liner using a neutral cleaner. Rinse thoroughly after cleaning.

3) Air Filter

A plastic mesh air filter removes dirt or dust from the air, and keeps the condenser from getting clogged. As the filter gets clogged, the icemaker's performance will be reduced. Check the filter at least twice a month. When clogged, use warm water and a neutral cleaner to wash the filter.

4) Condenser

Check the condenser once a year, and clean if required by using a brush or vacuum cleaner. More frequent cleaning may be required depending on the location of the icemaker.