

# Hoshizaki America, Inc.

Self-Contained Cubelet

Models  
F-300BAF



“A Superior Degree  
of Reliability”

[www.hoshizaki.com](http://www.hoshizaki.com)

## INSTRUCTION MANUAL



Issued: 5-11-1998  
Revised: 12-30-2004

## — **IMPORTANT** —

Only qualified service technicians should attempt to install, service or maintain this icemaker. No installation, service or maintenance should be undertaken until the technician has thoroughly read this Instruction Manual. Likewise, the owner/manager should not proceed to operate the icemaker until the installer has instructed them on its proper operation.

HOSHIZAKI provides this manual primarily to assist qualified service technicians in the installation, maintenance and service of the icemaker.

Should the reader have any questions or concerns which have not been satisfactorily addressed, please call or write to the HOSHIZAKI Technical Support Department for assistance.

HOSHIZAKI AMERICA, INC.  
618 Highway 74 South  
Peachtree City, GA 30269

Attn: HOSHIZAKI Technical Support Department

Phone: 1-800-233-1940 Technical Service  
(770) 487-2331  
Fax: (770) 487-3360

Web Site: [www.hoshizakiamerica.com](http://www.hoshizakiamerica.com)

Note: To expedite assistance, all correspondence/communication **MUST** include the following information:

- Model Number
- Serial Number
- Complete and detailed explanation of the problem

- Please review this manual. It should be read carefully before the icemaker is installed and operated. Only qualified service technicians should install, service and maintain the icemaker. This manual should be made available to the technician prior to installation, maintenance or service.
- Keep this manual with the icemaker for later reference.

## CONTENTS

I. Specifications .....	4
1. Nameplate Rating .....	4
2. Dimensions/Connections .....	5
II. Installation and Operating Instructions .....	6
1. Checks Before Installation .....	6
2. How to Remove Panels .....	6
3. Location .....	7
4. Setup .....	7
5. Electrical Connection .....	7
6. Water Supply and Drain Connections .....	8
7. Final Checklist .....	9
8. Startup .....	10
9. Preparing the Icemaker for Long Storage .....	11
III. Cleaning and Maintenance .....	12
1. Cleaning and Sanitizing Instructions .....	12
[a] Cleaning Solution .....	12
[b] Cleaning Procedure .....	12
[c] Sanitizing Solution .....	13
[d] Sanitizing Procedure - Initial .....	14
[e] Sanitizing Procedure - Final .....	14
2. Maintenance .....	16

## I. Specifications

### 1. Nameplate Rating

[a] F-300BAF (air-cooled)



See the nameplate for electrical and refrigeration specifications. This nameplate is located on the upper right hand side of rear panel.

We reserve the right to make changes in specifications and design without prior notice.

## 2. Dimensions/Connections

F-300BAF

Unit = inches [mm.]

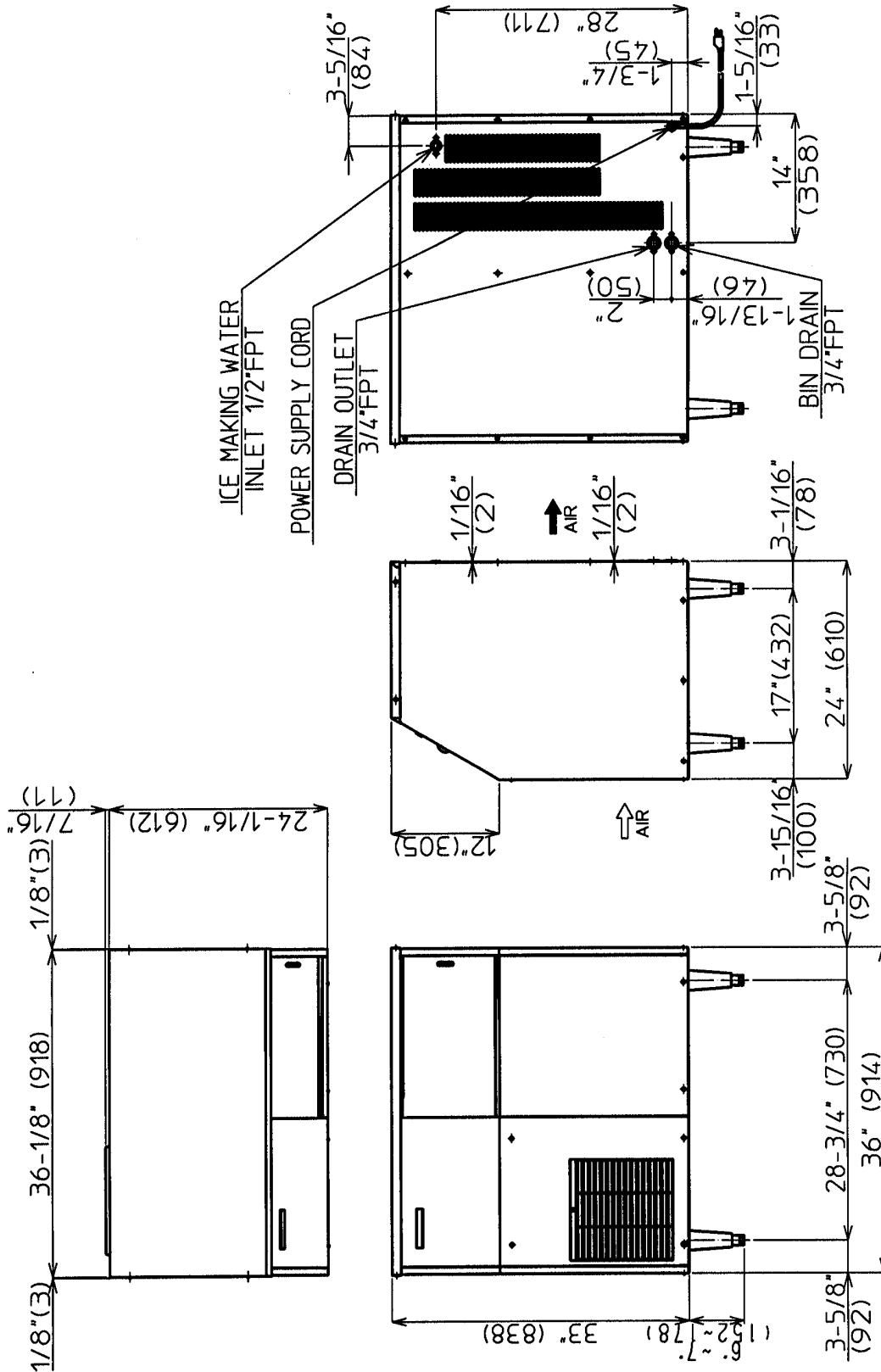

## II. Installation and Operating Instructions

### 1. Checks Before Installation

#### WARNING

Remove shipping carton, tape(s) and packing. If packing material is left in the icemaker, it will not work properly.

#### IMPORTANT

Ensure all components, fasteners and thumbscrews are securely in place.

- 1) Remove the front panel to prevent damage when installing the icemaker. See Fig. 1.
- 2) Remove the package containing the accessories from inside the icemaker.
- 3) Remove the protective plastic film from the panels. If the icemaker is exposed to the sun or to heat, remove the film after the icemaker cools.
- 4) Check that the refrigerant lines do not rub or touch lines or other surfaces, and that the fan blade turns freely.
- 5) Check that the compressor is snug on all mounting pads.
- 6) See the nameplate on the upper right hand side of the left side panel, and check that your voltage supplied corresponds with the voltage specified on the nameplate.

### 2. How to Remove Panels

- See Fig. 1

- a) Front Panel . . . . . Remove the screws.  
(left) Lift up and pull toward you.
- b) Top Panel . . . . . Remove the screws,  
then lift off.

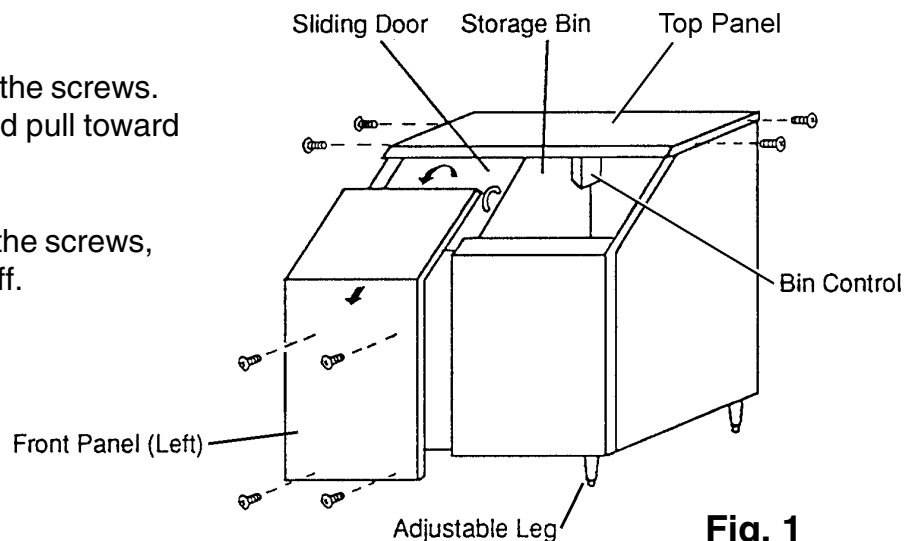

Fig. 1

### 3. Location

#### WARNING

This icemaker is not intended for outdoor use. Normal operating ambient temperature should be within +45°F to +100°F; Normal operating water temperature should be within +45°F to +90°F. Operation of the icemaker, for extended periods, outside of these normal temperature ranges may affect production capacity.

For best operating results:

- Icemaker should not be located next to ovens, grills or other high heat producing equipment.
- Location should provide a firm and level foundation for the equipment.
- Allow 6" clearance at rear and sides for proper air circulation and ease of maintenance and /or service should they be required. Allow 24" clearance at top to allow for removal of the auger.

### 4. Setup

- 1) Unpack the icemaker and remove all shipping carton, tape(s) and packing.
- 2) Provide four 6" adjustable legs and attach them to the bottom of the icemaker.
- 3) Position the icemaker in the selected permanent site.
- 4) Level the icemaker in both the left-to-right and front-to-rear directions.

### 5. Electrical Connection

- This icemaker must have a separate power supply or receptacle of proper capacity. See the nameplate.
- Usually an electrical permit and services of a licensed electrician are required.

## 6. Water Supply and Drain Connections

### - See Fig. 2

- External filters, strainers or softeners may be required depending on the water quality.
- Water supply inlet is 1/2" female pipe thread (FPT).
- A water supply line shut-off valve and drain valve should be installed. A minimum of 3/8" OD copper tubing is recommended for the water supply lines.
- Water supply pressure should be a minimum of 10 PSIG and a maximum of 113 PSIG. If the pressure exceeds 113 PSIG, the use of a pressure reducing valve is required.
- Drain outlet for icemaking is 3/4" FPT. The icemaker drain piping connection must be made separately from the bin drain.
- The drains must have 1/4" fall per foot on horizontal runs to get a good flow.
- The drains should not be piped directly to the sewer system. An air gap of a minimum of 2 vertical inches should be between the end of the drain pipe from the icemaker or the ice bin and the floor drain.
- A plumbing permit and services of a licensed plumber may be required in some areas.

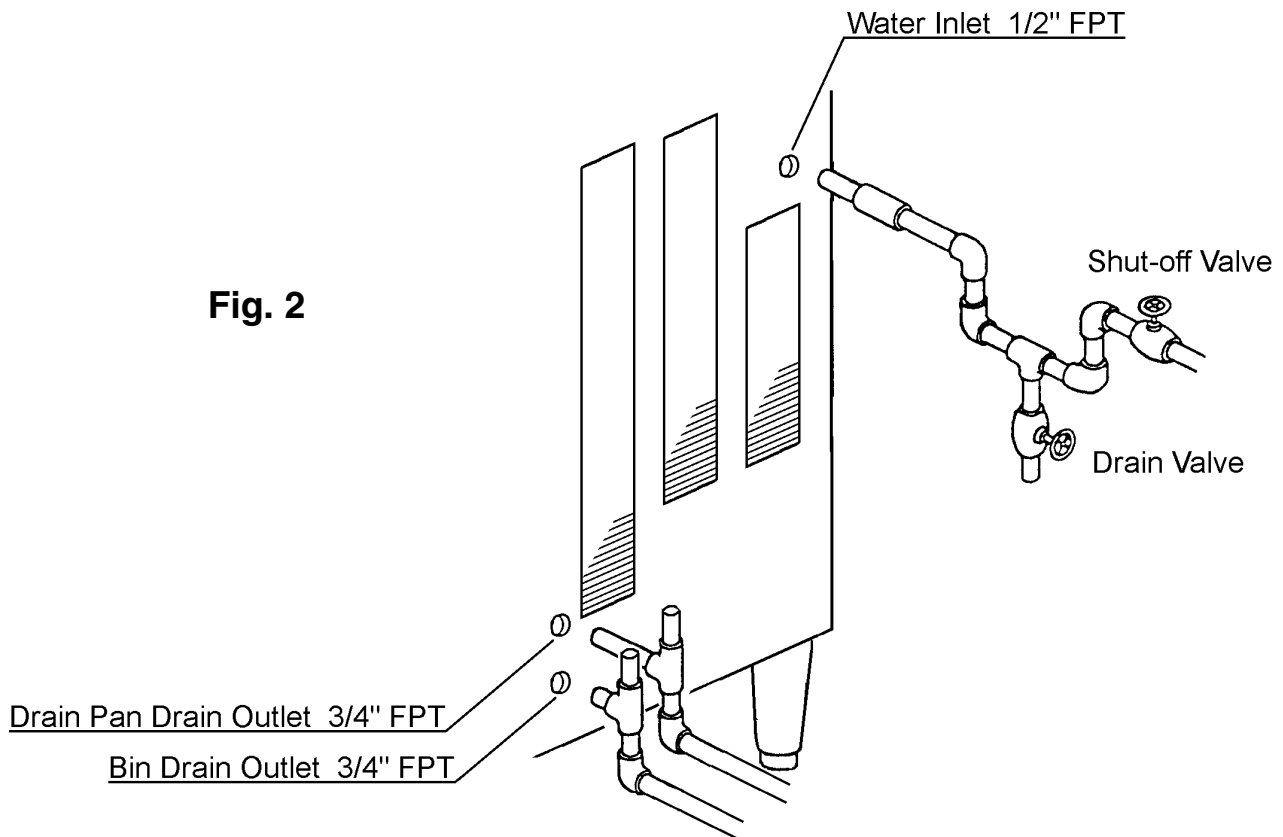

## 7. Final Checklist

- 1) Is the icemaker level?
- 2) Is the icemaker in a site where the ambient temperature is within +45°F to +100°F and the water temperature within +45°F to +90°F all year around?
- 3) Is there at least 6" clearance at rear and sides and 24" at top for maintenance or service?
- 4) Have all shipping carton, tape(s) and packing been removed from the icemaker?
- 5) Are all components, fasteners and thumbscrews securely in place?
- 6) Have all electrical and piping connections been made?
- 7) Has the power supply voltage been checked or tested against the nameplate rating? And has a proper ground been installed in the icemaker?
- 8) Are the water supply line shut-off valve and drain valve installed? Has the water supply pressure been checked to ensure a minimum of 10 PSIG and a maximum of 113 PSIG?  
  
Note: The icemaker may stop running when the water supply is OFF, or if the pressure is below 10 PSIG. When the proper water pressure is reached, the icemaker will automatically start running again.
- 9) Have the compressor hold-down bolts and refrigerant lines been checked against vibration and possible failure?
- 10) Has the bin control switch been checked for correct operation? Move the actuator located on the inside of the bin top panel. The compressor should stop within 90 seconds, and the gear motor within 150 seconds.
- 11) Has the end user been given the instruction manual, and instructed on how to operate the icemaker and the importance of the recommended periodic maintenance?
- 12) Has the end user been given the name and telephone number of an authorized service agent?
- 13) Has the warranty tag been filled out and forwarded to the factory for warranty registration?
- 14) Have the safety switch brackets moved out of location during shipping? Check on top of the spout and connecting the evaporator to the bin wall.

15) Has the safety switch been checked for correct operation? Activate the safety switch on top of the spout. The ice machine should shut down immediately. Turn the ice machine off, then back on, to reset.

## 8. Startup

### WARNING

1. All parts are factory-adjusted. Improper adjustments may result in failure.
2. If the unit is turned off, wait for at least 3 minutes before restarting the icemaker to prevent damage to the compressor.

- 1) Clean the storage bin. (See "III. 2. Maintenance.")
- 2) Open the water supply line shut-off valve.
- 3) Remove the front panel.
- 4) Move the flush switch on the control box to the "ICE" position.
- 5) Turn on the power switch on the control box.
- 6) Replace the front panel in its correct position.
- 7) Plug in the icemaker.

## 9. Preparing the Icemaker for Long Storage

- See Fig. 3

### WARNING

When shutting off the icemaker for an extended time, drain out all water from the water line and remove the ice from the storage bin. The storage bin should be cleaned and dried. Drain the icemaker to prevent damage to the water supply line at sub-freezing temperatures, using air or carbon dioxide. Shut off the icemaker until the proper ambient temperature is resumed.

- 1) Run the icemaker with the water supply line shut-off valve closed.
- 2) Open the drain valve and blow out the water inlet line by using air pressure.
- 3) Unplug the icemaker.
- 4) Remove the front panel (left).
- 5) Move the flush switch on the control box to the "FLUSH" position.
- 6) Plug in the icemaker, and drain out all water from the water line.
- 7) Unplug the icemaker.
- 8) Turn off the power switch on the control box.
- 9) Replace the front panel in its correct position.
- 10) Close the drain valve.
- 11) Remove all ice from the storage bin, and clean the bin.

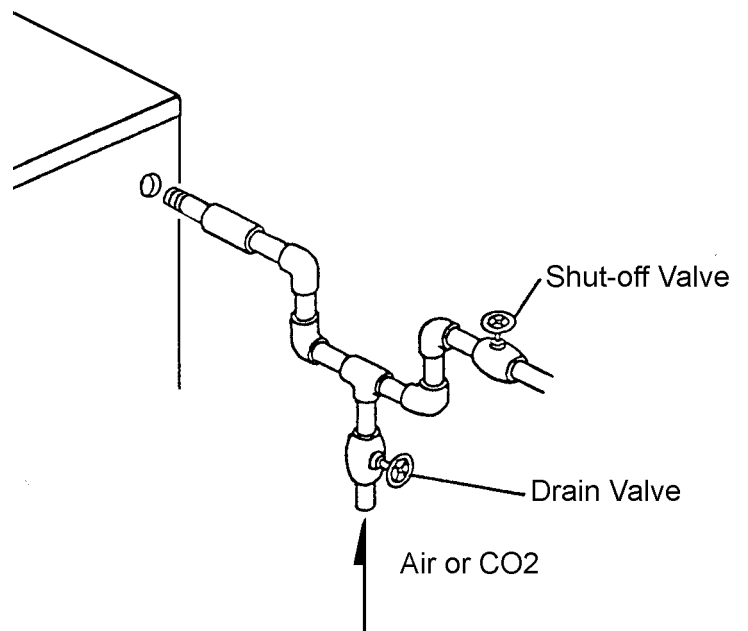

**Fig. 3**

### III. Cleaning and Maintenance

#### IMPORTANT

Ensure all components, fasteners and thumbscrews are securely in place after any maintenance or cleaning is done to the equipment.

#### 1. Cleaning and Sanitizing Instructions

#### WARNING

1. HOSHIZAKI recommends cleaning this unit at least once a year. More frequent cleaning, however, may be required in some existing water conditions.
2. To prevent injury to individuals and damage to the icemaker, do not use ammonia type cleaners.
3. Always wear liquid-proof gloves to prevent the cleaning and sanitizing solutions from coming into contact with skin.

#### [a] Cleaning Solution

Dilute 4.8 fl. oz. (142 ml) of recommended cleaner Hoshizaki “Scale Away” or “LIME-A-WAY” (Economics Laboratory, Inc.) with 0.8 gallons (3 l) of warm water. This is a minimum amount. Make more solution if necessary.

#### IMPORTANT

For safety and maximum effectiveness, use the solution immediately after dilution.

#### [b] Cleaning Procedure

- 1) Remove the front panel and the top panel, then turn off the power supply.
- 2) Close the water supply line shut-off valve.
- 3) Remove all ice from the storage bin.
- 4) Move the flush switch to the “FLUSH” position.
- 5) Turn on the power supply and drain out all water from the water line.
- 6) Turn off the power supply.  
Note: This unit is designed to start operating when the reservoir is filled with water.

- 7) In the storage bin, remove the thumbscrews attaching spout (B), then remove spout (B) and spout packing (B).

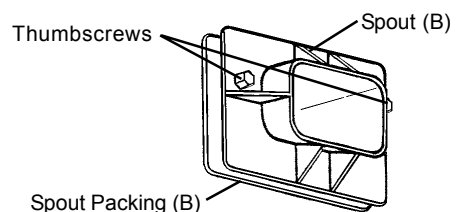

**Fig. 4**

- 8) Remove the thumbscrews attaching spout (A) to the evaporator assembly and lift off spout (A) and spout packing (A).
- 9) Pour the cleaning solution over the extruding head until the evaporator assembly and the reservoir are filled and the solution starts to overflow into the drain pan.  
Note: If there is excess scale on the extruding head, fill the evaporator assembly and reservoir as described above, then use a clamp on the reservoir hose between the reservoir and evaporator assembly to block flow. Pour additional cleaning fluid over the extruding head until the evaporator assembly is completely full.
- 10) Using the thumbscrews, replace spouts (A) and (B) and spout packings (A) and (B) in their correct positions.
- 11) Allow the icemaker to sit for about 10 minutes before operation. If you placed a clamp on the reservoir hose in step 9, remove it before operation.
- 12) Move the flush switch to the "ICE" position, then turn on the power supply. Replace the top panel and the front panel in their correct positions. Make ice using the solution until the icemaker stops making ice.
- 13) Remove the front panel.
- 14) Move the flush switch to the "FLUSH" position to drain the remainder of the solution.
- 15) After the solution is drained, move the flush switch to the "ICE" position.
- 16) Replace the front panel in its correct position.
- 17) Open the water supply line shut-off valve, and supply water to the reservoir.
- 18) When the gear motor starts, remove the top panel and front panel. Turn off the power supply.
- 19) Drain out all water from the water line. See 4) through 6).

### **[c] Sanitizing Solution**

Dilute 2.5 fl. oz. (74 ml or 5 tbs) of IMS-II Sanitizer or a 5.25% sodium hypochlorite solution (chlorine bleach) with 5 gallons (19 l) of warm water.

#### **IMPORTANT**

For safety and maximum effectiveness, use the solution immediately after dilution.

### [d] Sanitizing Procedure - Initial

- 1) Close the water supply line shut-off valve.
- 2) In the storage bin, remove the thumbscrews attaching spout (B), then remove spout (B) and spout packing (B).
- 3) Remove the thumbscrews attaching spout (A) to the evaporator assembly and lift off spout (A) and spout packing (A), and the cylinder packing.
- 4) Pour the sanitizing solution over the extruding head until the evaporator assembly and the reservoir are filled and the solution starts to overflow into the drain pan.
- 5) Remove the thumbscrews attaching the bin control assembly to the inside of the bin top panel.
- 6) Remove the snap pin, shaft and actuator.
- 7) Remove the sliding door.
- 8) Soak the removed parts in .25 gallons (1 l) of sanitizing solution for 10 minutes then wipe them down.
- 9) Rinse the parts thoroughly.

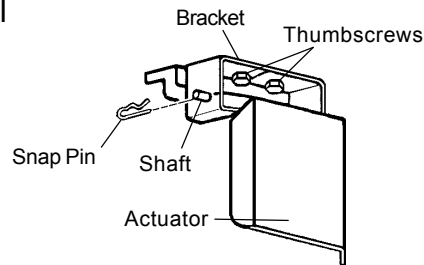

**Fig. 5**

### **IMPORTANT**

If the solution is left on these parts, they will rust.

- 10) Replace all parts in their correct positions.
- 11) Move the flush switch to the “ICE” position, then turn on the power supply. Replace the top panel and the front panel in their correct positions. Make ice using the solution until the icemaker stops making ice.

### [e] Sanitizing Procedure - Final

- 1) Remove the front panel and the top panel, then turn off the power supply.
- 2) Move the flush switch to the “FLUSH” position.
- 3) Turn on the power supply and drain out all water from the water line.
- 4) Turn off the power supply.  
Note: This unit is designed to start operating when the reservoir is filled with water.
- 5) In the storage bin, remove the thumbscrews attaching spout (B), then remove spout (B) and spout packing (B).

- 6) Remove the thumbscrews attaching spout (A) to the evaporator assembly and lift off spout (A) and spout packing (A).
- 7) Pour the sanitizing solution over the extruding head until the evaporator assembly and the reservoir are filled and the solution starts to overflow into the drain pan.
- 8) Using the thumbscrews, replace spouts (A) and (B) and spout packings (A) and (B) in their correct positions.
- 9) Allow the icemaker to sit for about 10 minutes before operation.
- 10) Move the flush switch to the "ICE" position, then turn on the power supply. Replace the top panel and the front panel in their correct positions. Make ice using the solution until the icemaker stops making ice.
- 11) Remove the front panel.
- 12) Move the flush switch to the "FLUSH" position to drain the remainder of the solution.
- 13) After the solution is drained, move the flush switch to the "ICE" position.
- 14) Replace the front panel in its correct position.
- 15) Open the water supply line shut-off valve and supply water to the reservoir.
- 16) When the gear motor starts, remove the front panel and turn off the power supply.
- 17) Drain out all water from the water line. See 2) and 3).
- 18) Move the flush switch to the "ICE" position and run the icemaker.
- 19) Turn off the power supply after 30 minutes.
- 20) Pour warm water into the storage bin to melt all ice, then clean the bin liner with the solution.
- 21) Flush out any solution from the storage bin.
- 22) Turn on the power supply and start the automatic icemaking process.

**IMPORTANT**

1. After cleaning, do not use ice made from the sanitizing solution. Be careful not to leave any solution in the storage bin.
2. Follow carefully any instructions provided with the bottles of cleaning or sanitizing solution.
3. Never run the icemaker when the reservoir is empty.

## 2. Maintenance

### IMPORTANT

1. This icemaker must be maintained individually, referring to the instruction manual and labels provided with the icemaker.
2. To obtain the optimum performance of this icemaker, the following consumable parts need periodic inspection, maintenance and replacement:

Extruding Head  
Housing  
Gear Motor  
Auger  
Mechanical Seal

These parts should be inspected at least once a year or every 10,000 hours of operation. Their service life, however, depends on water quality and environment. More frequent inspection and maintenance are recommended.

Consult with your local distributor about inspection and maintenance service. To obtain the name and phone number of your local distributor, call Hoshizaki Technical Support Department at 1-800-233-1940.

#### 1) Exterior Panels

Wipe the exterior occasionally with a clean, soft cloth. Use a damp cloth containing a neutral cleaner to wipe off oil or dirt build up.

#### 2) Storage Bin and Scoop

- Wash your hands before removing ice. Use the plastic scoop provided (accessory).
- The storage bin is for ice use only. Do not store anything else in the bin.
- Keep the scoop clean. Clean using a neutral cleaner and rinse thoroughly.
- Clean the bin liner using a neutral cleaner. Rinse thoroughly after cleaning.

### 3) Air Filter

A plastic mesh air filter removes dirt or dust from the air, and keeps the condenser from getting clogged. As the filter gets clogged, the icemaker's performance will be reduced. Check the filter at least twice a month.

- 1) Remove the screw, push down the lock and take off the louver.
- 2) Remove the air filter by pushing it down.
- 3) Clean the air filter using a vacuum cleaner. When it is severely clogged, use warm water and a neutral cleaner to wash the air filter.
- 4) Rinse and dry the air filter thoroughly and place it in position.

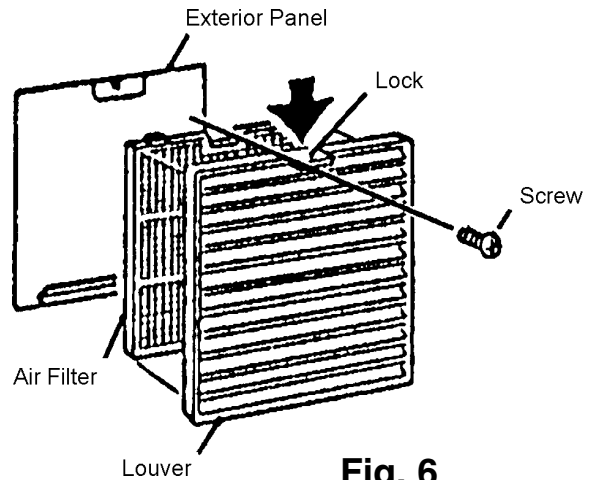

**Fig. 6**

### 4) Condenser

Check the condenser once a year, and clean if required by using a brush or vacuum cleaner. More frequent cleaning may be required depending on the location of the icemaker.

**HOSHIZAKI AMERICA, INC.**

---

618 Hwy. 74 S., Peachtree City, GA 30269 USA | TEL (770) 487-2331 | FAX (770) 487-3360 | [www.hoshizaki.com](http://www.hoshizaki.com) [91A2JA10E](#)