

Overshelf Kit

HS-5228, HS-5229, HS-5230, HS-5231

For Use with Hoshizaki Commercial Series Pizza Prep Table Models

Check to ensure that all parts are included:

Index No.	Description	HS-Kit	Part Number	Single Shelf Kit Qty	Double Shelf Kit Qty
	HS-Kit (includes items 1 through 12)	HS-5229 (CPT46)		1	-
		HS-5229 (CPT93)		2	-
		HS-5228 (CPT46)		-	1
		HS-5228 (CPT93)		-	2
		HS-5231 (CPT67)		1	-
		HS-5230 (CPT67)		-	1
1	Overshelf	HS-5229	2A7365-06	1	-
		HS-5228		-	2
		HS-5231	2A7365-05	1	-
		HS-5230		-	2
2	Square Tube	All HS Kits	4A5733-01	2	2
3	Square Tube Cap		4A5862-01	2	2
4	Square Tube Bracket		4A5958-01	2	2
5	Square Tube Support		4A5998-01	4	4
6	Hex Head Bolt - (6x12 mm)		7B02-0612	2	2
7	Hex Head Bolt - (6x50 mm)		7B02-0650	4	8
8	Hex Head Bolt - (6x60 mm)		7B02-0660	4	4
9	Flat Washer (28 mm)		4A0198-03	14	14
10	Lock Washer		7L22-0600	10	14
11	Hex Nut		7N12-0600	4	8
12	Flat Washer (M6)		7W22-0600	4	8

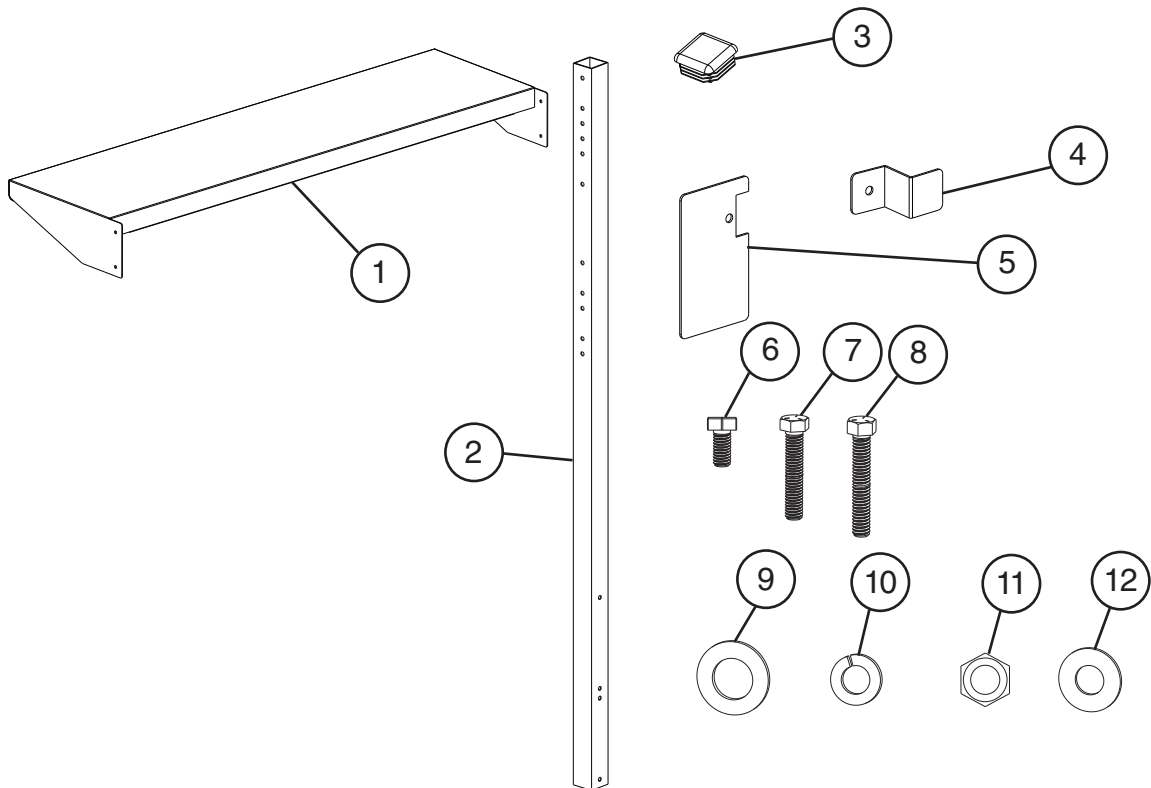

HS Kit Components

⚠ WARNING

- This appliance should be repaired only by qualified service personnel to reduce the risk of death, electric shock, serious injury, or fire.
- No installation or service should be undertaken until the technician has thoroughly read these instructions. Failure to install this kit in accordance with these instructions will adversely affect safety, performance, component life, and warranty coverage.
- To reduce the risk of electric shock, do not touch the plug with damp hands.
- Before servicing; empty the appliance, then unplug the appliance from the electrical outlet.
- Maximum load per shelf:

Total Maximum Weight Per Shelf	
CPT46/CPT93	CPT67
120 lb. (54 kg)	180 lb. (82 kg)

- Use care when stacking product on the shelves to prevent items from falling.
- Do not climb, stand, or hang on the appliance, drawers, or shelves. Death or serious injury could occur or the appliance could be damaged.

Installation Instructions

- 1) Remove all items from the appliance, then unplug the appliance from the electrical outlet. Access the rear of the appliance.
- 2) Using 6×60 hex head bolts (8), lock washers (10), and flat washers (9), secure square tubes (2) to the rear panel. See Fig. 1. Do not tighten at this time. Note: Leave enough room to install square tube supports (5) in step 3.
- 3) Using 6×12 hex head bolts (6), lock washers (10), and flat washers (9), place and secure square tube supports (5) and square tube brackets (4) to the rear panel and tighten.
- 4) Snug all hardware installed in steps 2 and 3.
- 5) Insert square tube caps (3) into the top of square tube (2).

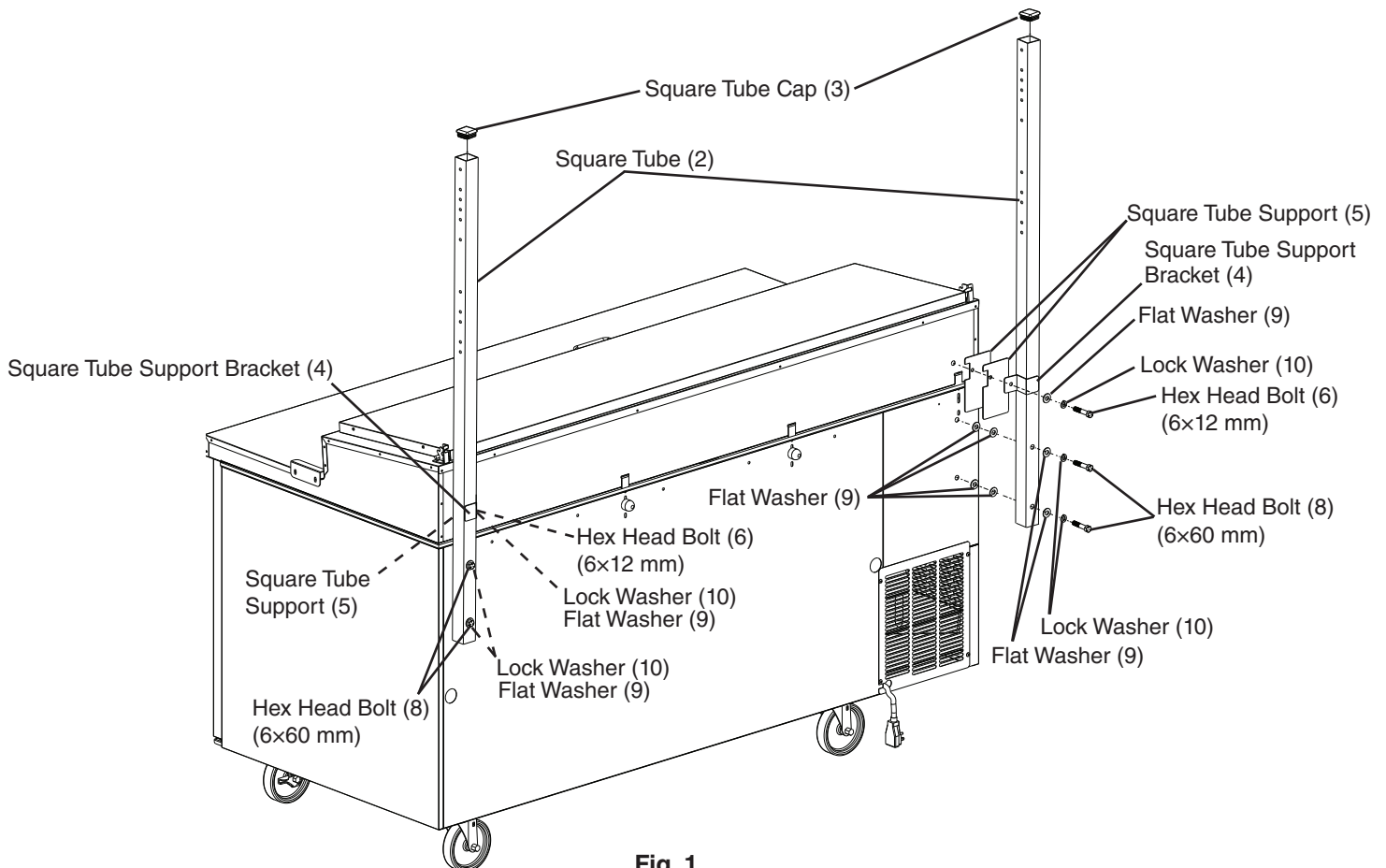

Fig. 1
Model Shown: CPT67

NOTICE! Help of an assistant is suggested for step 6. Multiple hole sets are provided to allow for various shelf heights. See Fig. 2. Be sure to use the corresponding holes on each side; shelves must be level.

	Lower Shelf Distance from Worktop	Upper Shelf Distance from Worktop
A	26 in. (660 mm)	38 in. (965 mm)
B	24 in. (610 mm)	36 in. (914 mm)
C	23 in. (584 mm)	34 in. (864 mm)

Upper Shelf Dimensions

Lower Shelf Dimensions

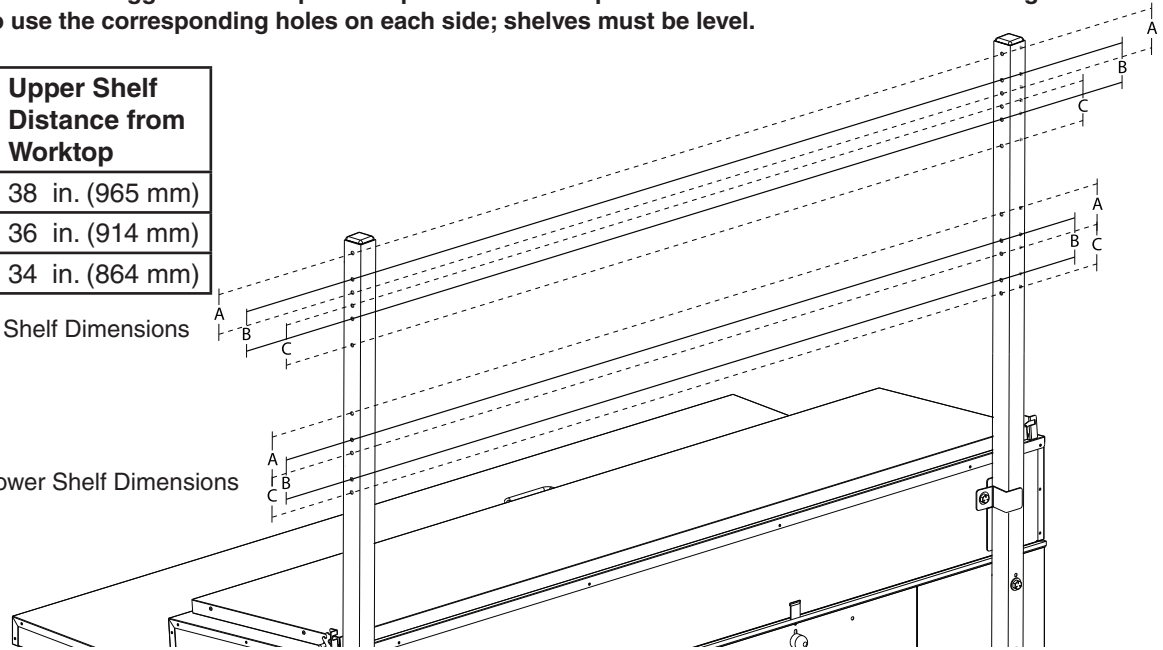

Fig. 2
Model Shown: CPT67

6) Using 6x50 hex head bolts (7), lock washers (10), flat washers (12), and hex nuts (11), place overshelf (1) in position and snug both sides of overshelf (1) to square tube (2). See Fig. 3.

Note: For double overshelf, repeat step 6 to install the second overshelf. **WARNING! Tip hazard. Shelves must face forward.**

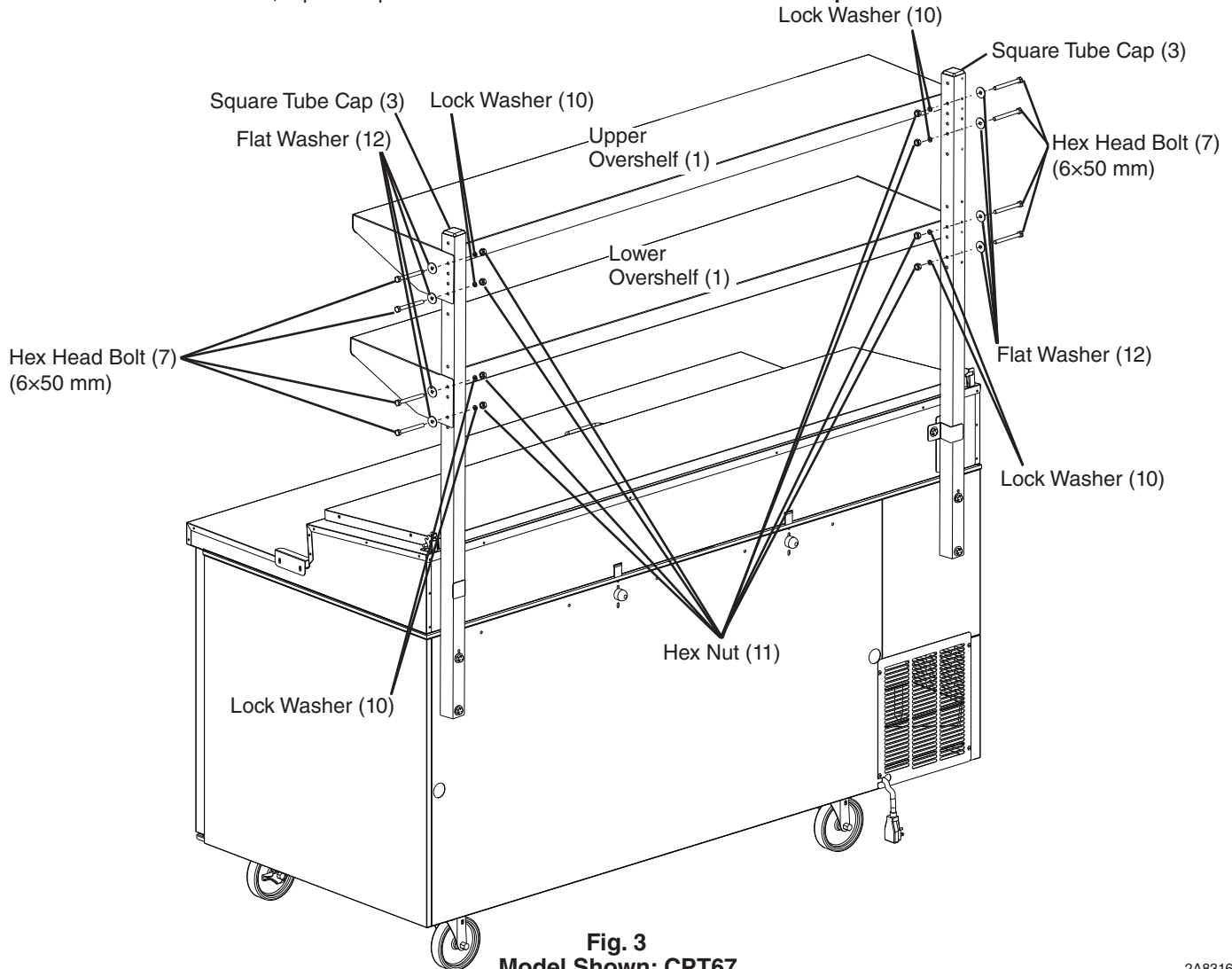

Fig. 3
Model Shown: CPT67

- 7) Tightened all hardware.
- 8) Place the appliance back in its original position, then plug the appliance back into the electrical outlet.
- 9) Allow the appliance to cool down prior to loading it with items.