

INSTRUCTIONS

WPR1260 WastePro™ Remote WASTE EQUIPMENT SYSTEM

MODEL

| | |
|----------------|------------------|
| <i>WPR1260</i> | <i>ML-130288</i> |
| <i>WP6</i> | <i>ML-130048</i> |
| <i>WP9</i> | <i>ML-130049</i> |



701 S. RIDGE AVENUE
TROY, OHIO 45374-0001

937 332-3000

www.hobartcorp.com

FORM 47602 (June 2016)

TABLE OF CONTENTS

| | |
|---|----|
| GENERAL | 3 |
| INSTALLATION | 4 |
| UNPACKING | 4 |
| LOCATION | 4 |
| VIBRATION ISOLATION FOOTPADS AND LEVELING | 4 |
| CHEMICAL FEEDER PUMP | 4 |
| THE FOLLOWING PARTS MAY BE INCLUDED (DEPENDING ON OPTIONS SELECTED) | 4 |
| SILVER SAVER — BY OTHERS (TROUGH EQUIPPED UNITS ONLY) | 5 |
| TROUGH GASKET (TROUGH EQUIPPED UNITS ONLY) | 5 |
| OPTIONAL MAGNET FOR SILVER SAVER (TROUGH EQUIPPED UNITS ONLY) | 5 |
| TROUGH PIPING DETAIL (TROUGH EQUIPPED UNITS ONLY) | 6 |
| FLANGE DETAIL | 6 |
| PULPER INSTALLED UNDER A DISH TABLE | 7 |
| PLUMBING CONNECTIONS | 8 |
| PULPER — FRESH COLD WATER CONNECTION | 8 |
| PULPER — DRAIN CONNECTION | 8 |
| WATERPRESS — FRESH HOT WATER CONNECTION | 8 |
| WATERPRESS — AUTO-RINSE DRAIN CONNECTION | 8 |
| SLURRY LINE, RETURN LINE, ETC. | 8 |
| PLUMBING INSTALLATION REQUIREMENTS | 9 |
| ELECTRICAL CONNECTIONS | 10 |
| REMOTE PUSH-BUTTON STATION | 10 |
| MOTOR ROTATION | 10 |
| ELECTRICAL INSTALLATION | 11 |
| OPERATION | 12 |
| CONTROLS | 12 |
| FEEDING INSTRUCTIONS | 13 |
| SHUTDOWN PROCEDURE | 14 |
| CLEANING | 14 |
| CLEANING INSTRUCTIONS | 14 |
| CLEANING COMPOUNDS | 14 |
| MAINTENANCE | 15 |
| MOTORS | 15 |
| WATERPRESS DRIVE | 15 |
| WATERPRESS TOP BEARING | 15 |
| TROUBLESHOOTING | 16 |
| SERVICE | 16 |

Installation, Operation and Care of WPR1260 WastePro™ Remote WASTE EQUIPMENT SYSTEM

SAVE THESE INSTRUCTIONS

GENERAL

The WPR1260 WastePro™ Remote Waste Equipment System prepares waste materials for disposal using one or more WPR1260 pulpers, a piping system and a waterpress. Paper, plastic, foil and food waste are fed into the pulper, shredded into small pieces in water to make a slurry. The waterpress lifts the slurry using a stainless steel screw inside of a perforated tubular screen. The water passes through the screen and is pumped back to the pulper. The solids continue up the screw where they are further compacted to a semi-dry pulp, exiting through the discharge chute to a waste container. Fresh make-up water is supplied to the pulper automatically through a solenoid valve controlled by a water level sensor. The original volume of waste material is reduced significantly.

The pulper has a 6 h.p. motor, stainless steel components, carbide and hardened stainless steel shredder blades. The waterpress can be model WP6 or model WP9 depending on volume, layout and piping requirements. The waterpress has a motor that turns the stainless steel screw and a pump that returns process water to the pulper; motors are sized for system requirements.

An optional feed tray (by Hobart) allows waste materials to be fed into the pulper. A feed trough (fabricated by tabling suppliers) allows waste materials and water to feed through an optional water-tight opening into the pulper. A flush nozzle with throttling valve (by Hobart) is an available option for the front end of the trough. A silver-saver sink (by others) can be installed in the feed trough; a silver saver magnet is an available option (by Hobart). Mounted below the trough, it restrains ferro-magnetic objects from entering into the pulper.

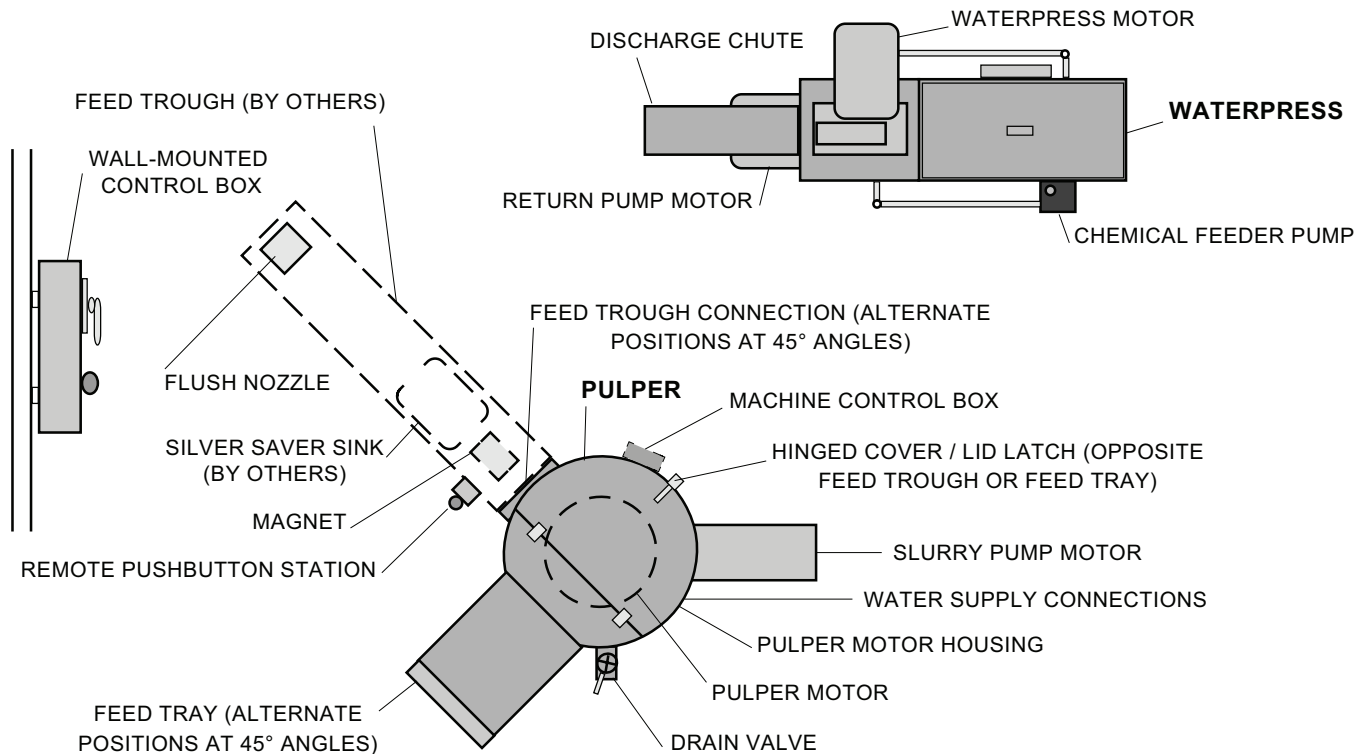

Fig. 1

INSTALLATION

Prior to installation, test the electrical service to assure that it agrees with the specifications on the machine data plate located on the front of the pulper.

UNPACKING

Immediately after unpacking, check for possible shipping damage. If the unit is found to be damaged, save the packaging material and contact the carrier within 5 days of delivery.

LOCATION

Locate the waste system near a floor drain; floor should be pitched a minimum of $\frac{1}{4}$ " per foot to the floor drain. A suitable amount of space should be provided for machine operation, cleaning and service.

VIBRATION ISOLATION FOOTPADS AND LEVELING

Vibration isolation footpads (standard — Fig. 2) must be installed on each of the legs of the pulper(s) and waterpress before making connections. Level the units by threading the adjustable feet up or down as necessary.

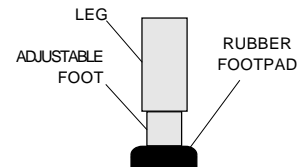

Fig. 2

CHEMICAL FEEDER PUMP (STANDARD)

The chemical feeder pump is mounted on the waterpress. It has its own on-off switch. When on, the chemical feeder pumps a chemical additive into the waterpress to control odors, to buffer the acidity of the system water and to reduce foaming. Contact your chemical supplier for a recommendation for the appropriate chemical additive. The recommended chemical pump setting is #1 which delivers 0.3 gallons per day. Each subsequent setting number is a direct multiple of setting #1. For example, setting #2 delivers 0.6 gallons per day, etc.

Insert the chemical tube with the plastic filter into the chemical container.

THE FOLLOWING PARTS MAY BE INCLUDED (DEPENDING ON OPTIONS SELECTED)

- 1 Nozzle for trough flush, rectangular piece has pipe thread with locknut on back.
- 1 Magnet (option) for trough.
- 6 Black Rubber Vibration Isolators for the legs; and a package of
- 6 Stainless steel screws (10-32 x $1\frac{1}{2}$ ") with nuts, washers and lockwashers.
- 1 Black Rubber Gasket slit curtain for trough opening; which also includes approximately
- 16 Stainless steel screws (10-32 x $1\frac{1}{2}$ ") with nylon stop nuts.
- 1 Push-button Station with Start, Stop and Timed Stop switches (second p/b station is an option).
- 2 Remote Control Box (for wall mounting).

SILVER SAVER — BY OTHERS (TROUGH EQUIPPED UNITS ONLY)

Silver saver sink to be fabricated into trough by others. It is recommended that a drain be provided in the silver saver sink and plumbed to a floor drain (by others). A shut-off valve must be installed in this drain line (provided and installed by others).

TROUGH GASKET (TROUGH EQUIPPED UNITS ONLY)

Install the trough gasket between the pulper's Trough Flange and the trough's outlet. Drill a hole pattern in the pulper's Trough Opening flange to match the holes in the hole pattern in the trough outlet flange; secure with the provided hardware.

OPTIONAL MAGNET FOR SILVER SAVER (TROUGH EQUIPPED UNITS ONLY)

Install the magnet underneath the silver saver by tack welding to the under side. Alternatively, drill four $\frac{7}{32}$ " diameter holes in the silver saver, and secure the magnet with the hardware, provided; seal the heads of the screws with silicone sealant. Refer to Fig. 3 for position of the magnet; refer to Fig. 4 for mounting detail.

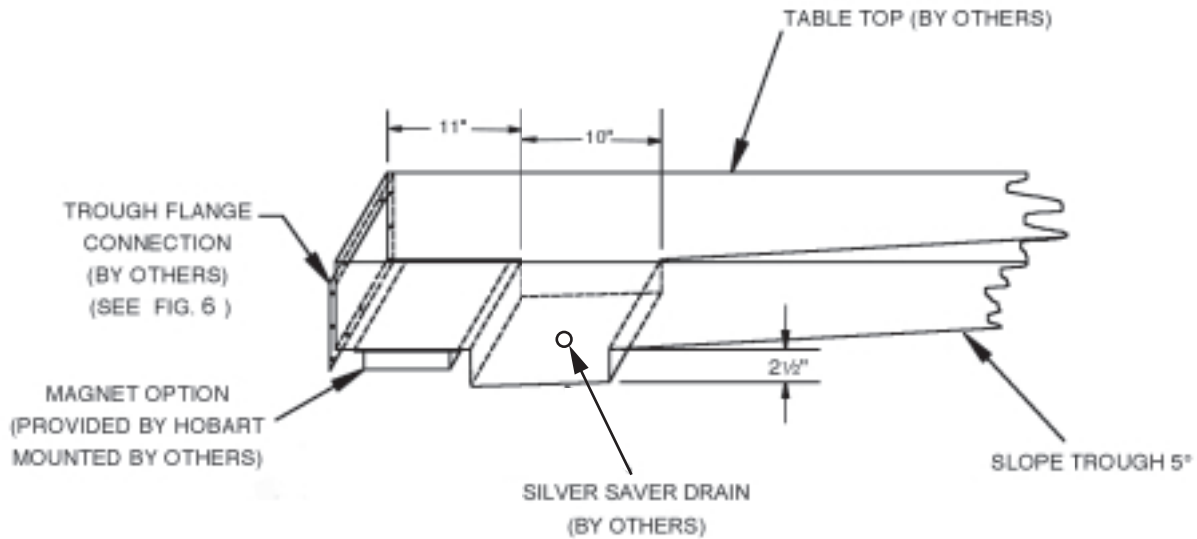

Fig. 3

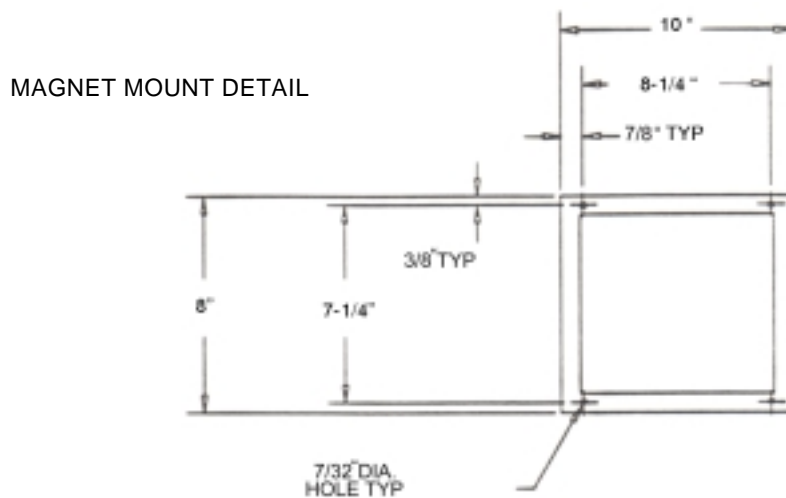

Fig. 4

TROUGH PIPING DETAIL (TROUGH EQUIPPED UNITS ONLY)

Install piping from the return water outlet to the trough flush nozzle as shown, (Fig. 5).

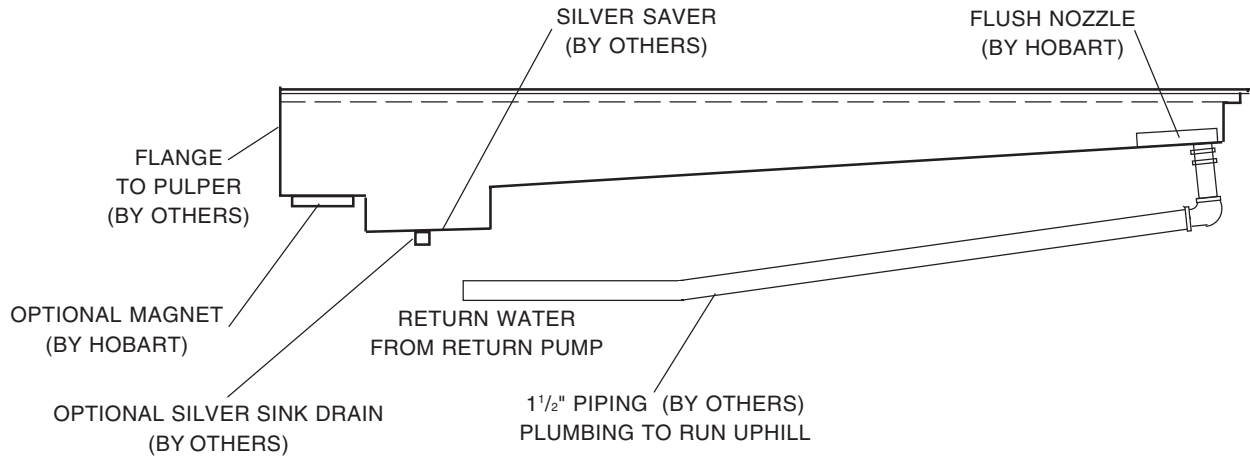

Fig. 5

FLANGE DETAIL

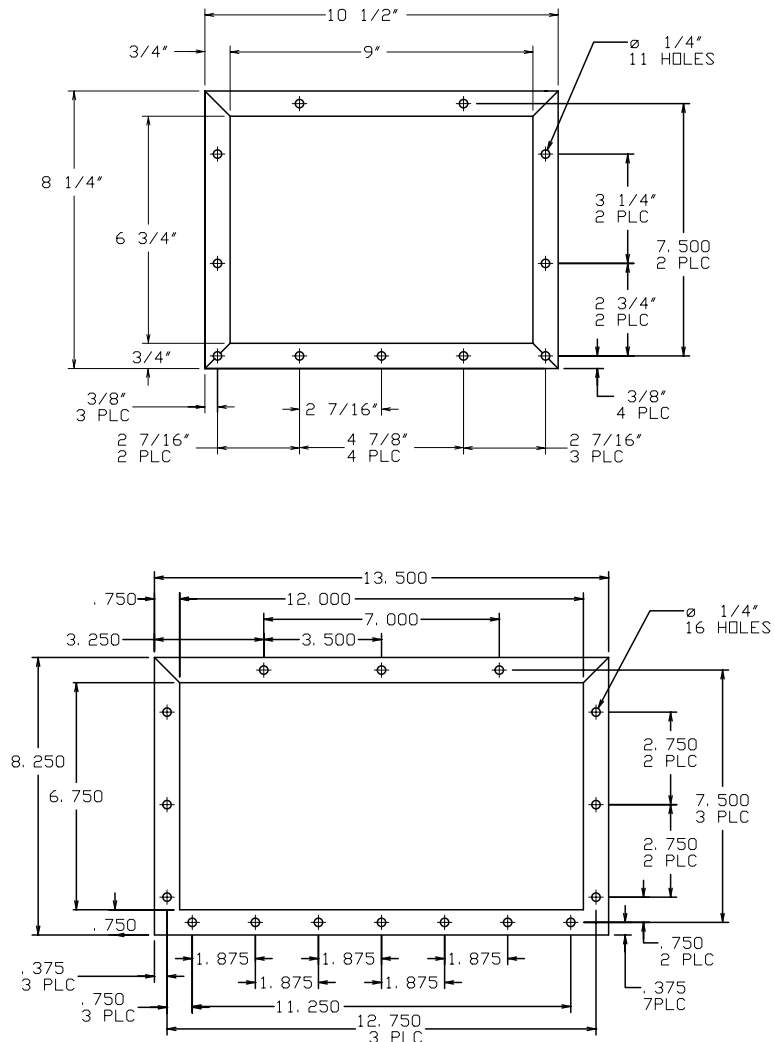

Fig. 6

PULPER INSTALLED UNDER A DISH TABLE

- 1) Cut an 20¹/₈" diameter hole in the top of the table as shown in the installation drawing.
- 2) Center the transition ring, provided, beneath the opening and weld it into place as shown.
- 3) Move the pulper into position under the 20¹/₈" diameter hole.
- 4) Install the trough gasket, provided, between the pulper's inlet and the trough outlet. Match and drill the pulper trough flange to the hole pattern in the table's flange and secure with the hardware provided.

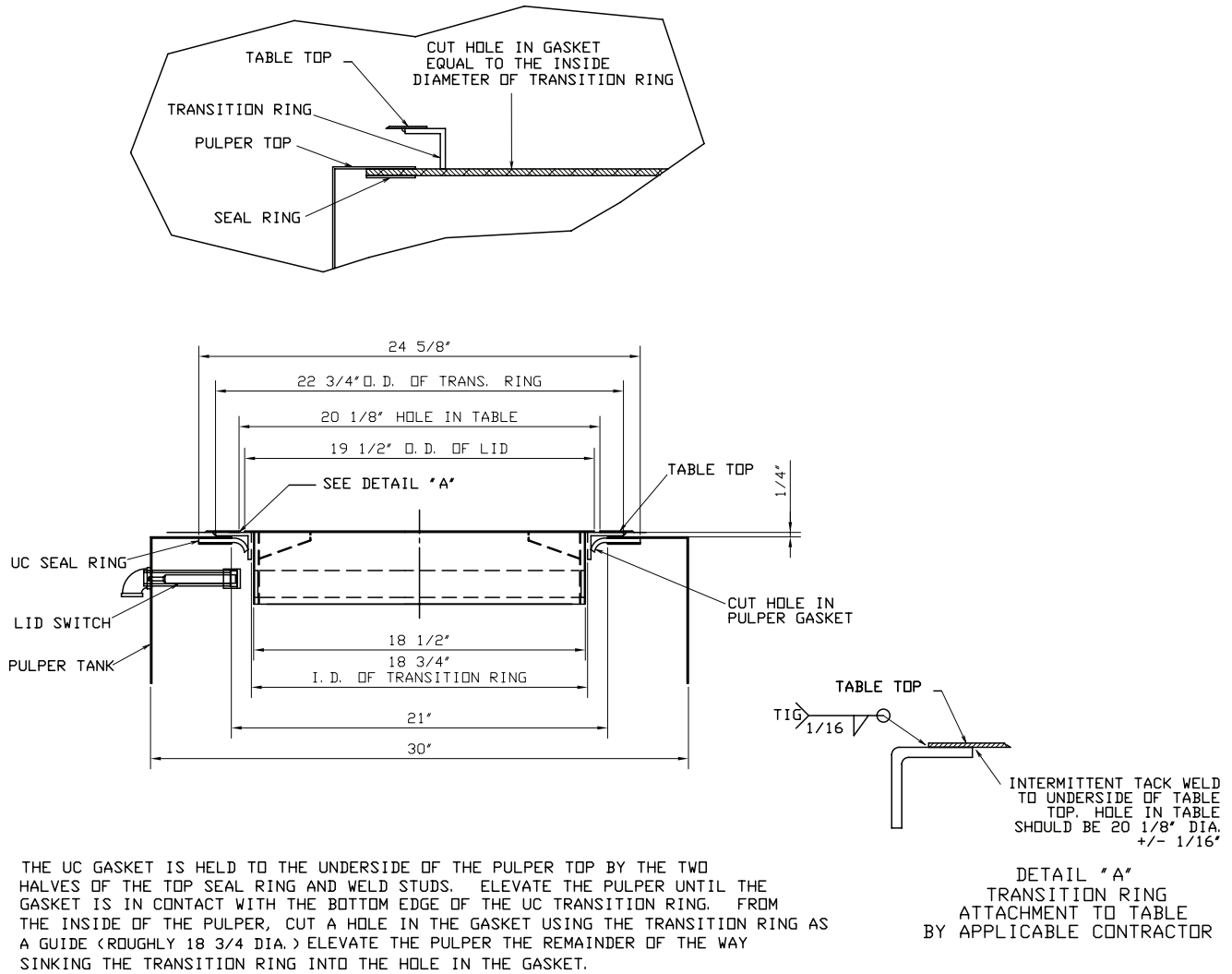

Fig. 7

PLUMBING CONNECTIONS

WARNING: PLUMBING CONNECTIONS MUST COMPLY WITH APPLICABLE SANITARY, SAFETY AND PLUMBING CODES.

1. Customer to provide all interconnecting slurry and return piping from waterpress to pulper(s). Also, overflow line and drain lines from waterpress to floor sink or floor drain.
2. All fittings must be pressure rated drainage type.
3. Floor drain or floor sink, 6" minimum (according to local code requirements) is/are to be kept clear of, but accessible to the unit.
4. Do not put any external strain on the Hobart equipment.
5. Protect all Hobart equipment and piping from freezing and condensation.
6. Hot and cold water hose bibs (for daily cleaning of unit) are to be installed clear of, but accessible to unit, with a heavy duty hose and squeeze valve (installed by others).

Pulper — Fresh Cold Water Connection

Connect the cold water supply to the $\frac{3}{4}$ " NPT internal-thread connector to the labeled port located on the side of the pulper tank with a manual shut-off valve. Incoming water pressure must be between 25 psig and 45 psig flowing.

Pulper — Drain Connection

Install 2" pipe from the pulper drain valve to a suitable floor drain per local code. Use an open connection to the floor drain. Do not make a direct plumbing connection. DO NOT REDUCE.

Waterpress — Fresh Hot Water Connection

Connect the hot water supply to the manual shut off valve on the piping assembly located on the side of the water press. Refer to table for pipe size. Incoming water pressure must be between 25 psig and 45 psig flowing.

| Waterpress Model | Valve Size |
|------------------|---------------------|
| WP6 | $\frac{1}{2}$ " NPT |
| WP9 | $\frac{3}{4}$ " NPT |

Waterpress — Auto-Rinse Drain Connection

Install $1\frac{1}{2}$ " pipe from waterpress auto-rinse drain, located on the return piping assembly, to a suitable floor drain per local code. Use an open connection to the floor drain. Do not make a direct plumbing connection. DO NOT REDUCE.

Slurry Line, Return Line, etc.

Connect the slurry line and the return line and other piping connections per the installation and piping drawings. Pressure test piping system for leaks at 150 psig.

PLUMBING INSTALLATION REQUIREMENTS

Use only specified pipe sizes. Do not increase or decrease pipe sizes from those specified.

Use standard "type M" copper piping for the slurry line and return line. Keep track of the direction of flow while plumbing the slurry and return lines (mark with a marker pen as you go along). Use only long radius T - Y type cleanouts or lateral type fittings and 45° elbows (Fig. 8). Install cleanouts at all turns and every 50 feet of straight pipe runs. Make sure cleanouts are accessible. Install cleanouts so the water does not flow into the cleanout to avoid probable jamming and clogging (Fig. 8).

Do not use 90° elbows or right angle turns — jams could occur and stop the flow.

Plan piping layouts without drastic elevation changes that could cause airlocks and stop the flow.

Terminate slurry and return lines with union or flanged type fittings.

Install a manual shutoff valve on incoming fresh water lines to allow servicing.

Install all valves and other components as shown on the installation drawings.

Piping must run uphill to trough connection if feed table is equipped with a trough.

At junctions, in pipe runs, use a "T-Y" or lateral type fitting and make accessible.

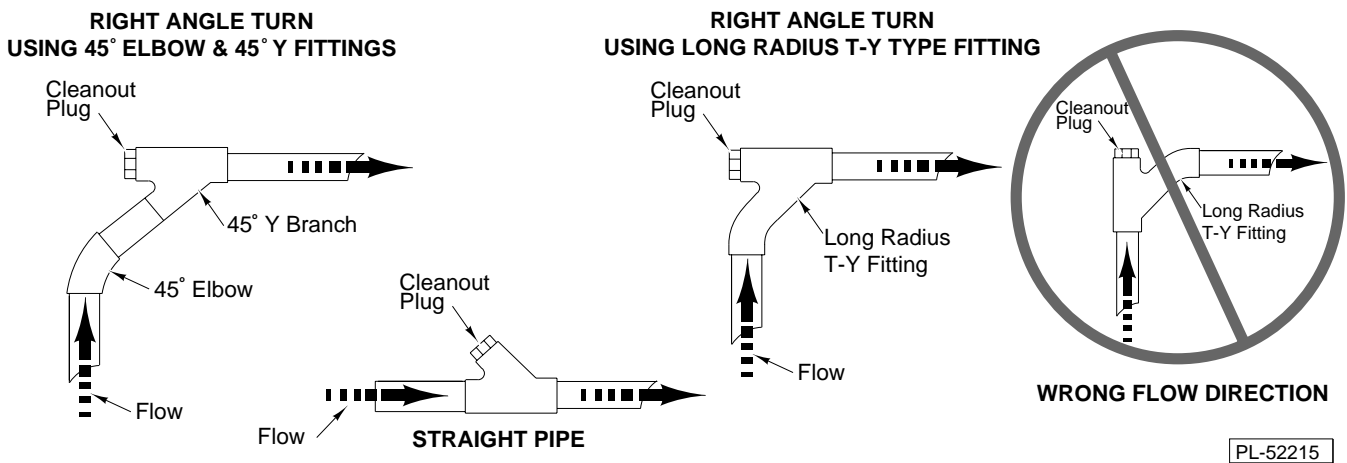

Fig. 8

ELECTRICAL CONNECTIONS

WARNING: ELECTRICAL AND GROUNDING CONNECTIONS MUST COMPLY WITH APPLICABLE PORTIONS OF THE NATIONAL ELECTRICAL CODE AND/OR OTHER LOCAL ELECTRICAL CODES.

WARNING: DISCONNECT THE ELECTRICAL POWER TO THE MACHINE AND FOLLOW LOCKOUT / TAGOUT PROCEDURES.

Refer to the electrical diagram located inside the wall-mounted control box and the installation drawings.

The wall-mounted control box must be located away from the pulper and waterpress. Mount the wall-mounted control box (NEMA 4) so that the bottom of the box is at least 42" above the finished floor. To facilitate field wiring, terminal blocks are provided in both the wall-mounted control box and the machine control box located on the side of the pulper tank. Conduit and wiring (by others) must be installed according to the electrical diagram and the installation drawings.

The incoming electrical power supply must be connected to the wall-mounted control box after the interconnections are made between the wall-mounted control box and the machine control box; terminals in each box are the same. This includes the ground wire.

Remote Push-Button Station (Standard)

One or more remote pushbutton stations with Start and Stop switches and the Timed Stop switch may be provided as ordered. These should be installed in a suitable and convenient location per local codes, the electrical diagram and installation drawings. They should be securely mounted and located at a convenient location (possibly on the dish table) for ease of operation, but not where they can be damaged.

Motor Rotation

The pulper drive and slurry pump motors and the waterpress drive and return pump motors must be checked for correct rotation after the machine has filled. Arrows are provided to indicate the correct directions of motor rotation.

To check motor rotation, turn power on. Start and Stop the machine. Observe direction of motors.

If incorrect direction of rotation is observed, **DISCONNECT ELECTRICAL POWER SUPPLY.** Interchange two power supply leads to the motor connection terminal block, in the prewired machine control box. The overloads may need to be reset. Close the electrical access panels. Reconnect electrical power. Turn the machine on momentarily to verify correct motor rotation.

Electrical Installation

Refer to the wiring diagram shipped with the machine in the wall-mounted control box.

- 1) Prewired control panels, operator devices and electric valves are furnished by Hobart.
- 2) Install 1^{1/4}" watertight conduit from the wall-mounted control box to the prewired machine control box, pull motor wires and control wires through this conduit and make the final connections.
- 3) Ground all electrical equipment. Transformer produces a 115 VAC nominal control circuit voltage. The PLC produces 24 VDC circuit voltage.
- 4) Remote push-button station(s) to be mounted and wired at the workstation by others. Bracket(s) for mounting push-button station(s) to be supplied by others.
- 5) Each push-button station houses two (2) illuminated push buttons plus a Timed Stop switch.
- 6) Control logic wiring shall be 18 AWG (THW) or equivalent for distances less than 120 feet.

OPERATION

WARNING: ROTATING PARTS INSIDE. KEEP HANDS OUT. DO NOT OPERATE WITHOUT: 1. ELECTRICAL INTERLOCK ON PULPER COVER AND/OR 2. ELECTRICAL INTERLOCK ON WATERPRESS DISCHARGE CHUTE. COVER MUST BE CLOSED AND THE DISCHARGE CHUTE MUST BE IN PLACE BEFORE UNIT WILL OPERATE.

WARNING: DISCONNECT ELECTRICAL POWER TO THE MACHINE AND FOLLOW LOCKOUT / TAGOUT PROCEDURES BEFORE CLEANING OR SERVICING.

CONTROLS

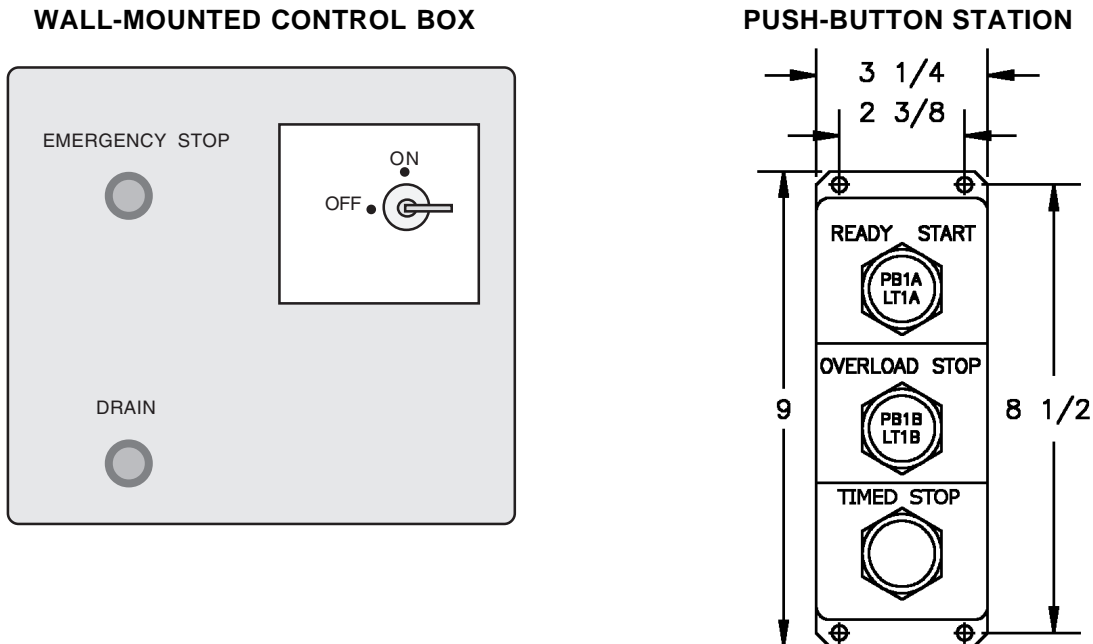

Fig. 8

To start the system, make sure the main power switch on the wall-mounted control box is in the ON position.

1. The hinged cover or undercounter cover plate must be closed (when equipped). Ensure the waterpress access cover is installed and the waterpress discharge chute cover is lowered.
2. Push the **START** button. The machine begins to fill with water. During the initial fill, the green start button light will flash. When the machine has filled to the proper level, the green start button light will illuminate solid.
3. Press the **START** button and wait until there is a continuous flow of water in the trough and/or feed tray (flush valves must be open and adjusted for proper throttling level if so equipped).
4. Begin feeding waste into the trough and/or feed tray.
5. To stop operation, press the **STOP** button.

FEEDING INSTRUCTIONS

Applications will vary widely; however, the following conditions could occur and should be monitored.

1. **Overfeeding.** The waste system is designed for continuous uniform feeding. The feed rate should not exceed 60 pounds in a three minute period. Overfeeding reduces the machine's rated operating capacity. **DO NOT OVERFEED.**

If waste material is delivered in large plastic bags, tear open the bag and feed one at a time. Unopened bags can fill with air and float, hampering machine operation.
2. **Foaming** is caused by contaminants in the water or by certain materials in the waste, such as glue in corrugated cardboard. Chemical defoaming agent can be added to reduce this condition; consult your chemical supplier.
3. **Corrosion.** If the water and / or waste is running in an acidic or alkaline condition, use of a buffering agent is recommended to neutralize the water. Regular testing is recommended since rapid corrosion due to acidic or alkaline conditions can result in costly repairs.
4. **Freezing.** Protect all equipment and piping from freezing. Insulation and heating cables should be used where equipment or piping is exposed.
5. **Non-Pulpables** (items that cannot be made into pulp). The WPR1260 Pulper is designed to handle a limited amount of non-pulpable materials. Lighter non-pulpable items are eventually cut and processed with the pulp; heavier materials settle to the bottom of the tank.
 - **DO NOT FEED** glass or metal containers; if present in the plastic bags, sort them out. Glass and metal containers are highly abrasive and accelerate machine wear. It is better to recycle glass or metal containers using a can or bottle crusher to reduce the volume.
 - **DO NOT FEED** rags, mop heads, wooden crates, oyster, or clam shells or heavy uncooked bones to the pulper. The waste system cannot efficiently reduce the volume of these items.

Caution: Heavy masonry materials, tramp iron and other materials of this nature can damage the cutters and seriously impair the pulper's ability to handle material of any kind.

Occasionally the amount of non-pulpable materials in the pulper tank may become excessive because of their slower processing rate. When this happens, press the STOP button and disconnect the electrical power. After machine is stopped, scoop out the non-pulpable materials. Then re-start the machine in the normal way.

When shutting down for short periods, it is not necessary to run the pulper until all the waste has been pumped out of the tank. Run pulper for a few minutes to thin down the slurry, and then shut off the machine.

During normal operation, there should be a strong flow of water returning to the pulper via trough and/or tray flush from the waterpress. This flow is a clue to the performance of the machine since a sharp reduction in this flow indicates the pulper is overloaded. If this occurs, stop feeding for a few minutes until return water resumes its normal flow.

Avoid slugging the machine with greasy swill or overloading the pulper with bread or pastry. Mix these items with bulky waste such as paper or corrugated boxes. The pulper will always perform better with clean water. It is good practice to drain the machine of dirty water after every meal period.

It is recommended that the discharge receptacle (garbage can) not be taller than the bottom of the discharge chute. Empty receptacle whenever necessary.

SHUTDOWN PROCEDURE

The following shutdown procedure must be followed before performing necessary cleaning and maintenance duties.

1. With the pulper still running, push the Timed Stop switch to permit the system to be shut down automatically. The pulper will stop when the shutdown timer has timed out. Do not add additional waste when the unit is operating in the Timed Stop cycle. If additional material needs to be added after the Timed Stop cycle has started, push the Timed Stop switch at any time and return to normal feeding.
2. Press the drain switch on the control panel to allow the unit to drain. Wait 30 seconds before proceeding to step 3.
3. Turn off the electrical power by turning the main power switch on the remote control box to the OFF position.

CLEANING

Cleaning requires only a few minutes daily, but must be done on a regular basis and proper facilities must be available. **NOTE:** If daily cleaning schedules are not followed, the machine will become unsightly and odors will develop and machine performance may decrease. A hose with a good quality, lever-operated nozzle should be available, preferably with hot water, for clean-up of both the machine and the surrounding area.

Cleaning Instructions

Shut down the machine per Shutdown Procedure above.

WARNING: DISCONNECT ELECTRIC POWER SUPPLY AT MAIN CONTROL BOX; PLACE A TAG AT THE DISCONNECT SWITCH INDICATING THAT YOU ARE WORKING ON THE CIRCUIT; AND WAIT FOR THE PULPER DISK TO COME TO A COMPLETE STOP BEFORE PERFORMING ANY CLEANING PROCEDURES.

1. Clean the pulper tank of any non-pulpable material. Use care, glass or other sharp items may be present in the pulper.
2. Wash the interior of the tank with a hose, suitable brush, detergent and deodorant or other cleaning solution. Be sure to clean the underside of the upper tank flange.
3. Using a spray hose, wash down the waterpress screen and interior walls of the waterpress and pulper tank. A long-handled, nylon bristle brush is recommended. Avoid spraying the chemical pump and control box.
4. Wipe down the equipment exterior.
5. It is not necessary to dig out the plug of pulp remaining at the top of the waterpress screw. After the machine has been cleaned, wash down the floor. Replace all removed parts. The system is now ready to be started.

Cleaning Compounds

Cleaning compounds used with the WPR1260 waste system should combine five important features: Detergency, disinfection, pH buffering, odor control and bio-degradability.

Consult your chemical supplier for recommendations.

MAINTENANCE

WARNING: DISCONNECT ELECTRICAL POWER TO THE MACHINE AND FOLLOW LOCKOUT / TAGOUT PROCEDURES BEFORE CLEANING OR SERVICING.

MOTORS

Motors should be kept free of dirt, and ventilation openings must not be restricted.

WATERPRESS DRIVE

The waterpress drive consists of a close coupled motor and speed reducer. The gears in the speed reducer run in an oil reservoir that must be checked every three months. With the machine stopped, remove the oil level plug. If the oil level is not high enough to drain out of the case, add a small quantity of Mobil Gear Oil #629 (Hobart Part Number: 103881-72) until it just starts to run out of the hole.

WATERPRESS TOP BEARING

The top bearing is equipped with a zerk fitting, and grease must be added monthly. Use a hand operated grease gun. Slowly dispense approximately one teaspoon of water repellent grease into the top bearing zerk fitting by squeezing the grease gun handle once.

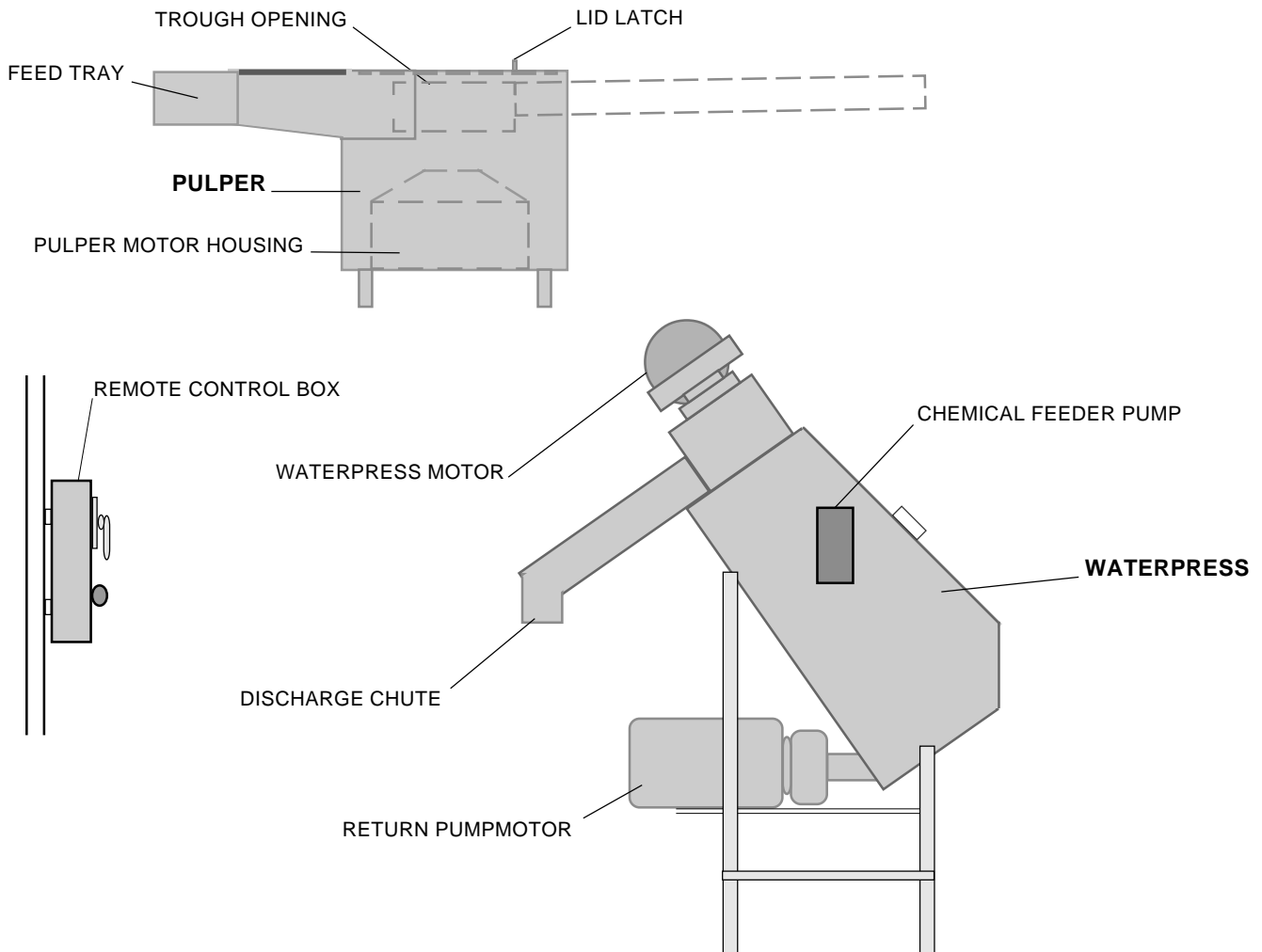

TROUBLESHOOTING

| SYMPTOM | POSSIBLE CAUSE | POSSIBLE CORRECTIVE ACTION |
|---|---|--|
| Machine will not start. | <ol style="list-style-type: none"> 1. Circuit breaker tripped at power supply. 2. Power handle on main control box is Off. 3. Pulper cover not in proper position. 4. Discharge chute lid not in proper position. 5. No water or not enough water in machine. 6. Overload is tripped. | <ol style="list-style-type: none"> 1. Reset circuit breaker. 2. Turn handle to On position. 3. Put pulper cover in proper position. 4. Put discharge chute lid in proper position. 5. See "No water or no water make-up." 6. Reset overload. |
| No water or no water make-up. | <ol style="list-style-type: none"> 1. Water supply off. 2. Drain valve open or leaking. | <ol style="list-style-type: none"> 1. Turn water supply on. 2. Close drain valve. Repair if leaking. |
| Pulper jammed. | <ol style="list-style-type: none"> 1. Pulper overloaded. 2. Pulping disc jammed with scrap metal or heavy material. | <ol style="list-style-type: none"> 1. Turn machine off at main control panel. Clean out and restart. 2. Turn machine off at main control panel. Remove metal or material. If material cannot be removed, call Service. |
| Waterpress jammed. | <ol style="list-style-type: none"> 1. Discharge chute outlet obstructed. 2. Hardened plug in waterpress. 3. Trash container is full and pulp is backing up in discharge chute. | <ol style="list-style-type: none"> 1. Turn machine off at main control panel. Remove residual pulp. 2. Remove hardened waste material. 3. Empty trash container and remove loose pulp from discharge chute. |
| Will not drain or drains very slowly. | <ol style="list-style-type: none"> 1. Pulper full of unpulped material. 2. Drain clogged. | <ol style="list-style-type: none"> 1. Run pulper until pulp has been processed. If it will not process the material, turn the machine off and clean out the pulper tank. 2. Use water pressure to eliminate clog. |
| Excessive foaming. | <ol style="list-style-type: none"> 1. Pulping of certain materials, such as glossy paper, cardboard, and potatoes will produce large quantities of foam. 2. Excessive deodorizer or detergent. | <ol style="list-style-type: none"> 1. Add defoaming agent. 2. Drain machine and refill with fresh water. 3. Turn pulper off when not feeding machine. |
| No overflow from drain fitting. | <ol style="list-style-type: none"> 1. Clogged overflow fitting. | <ol style="list-style-type: none"> 1. Clean overflow fitting with bottle brush. |
| Pulp coming out of waterpress is too wet. | <ol style="list-style-type: none"> 1. Screen clogged. | <ol style="list-style-type: none"> 1. Clean waterpress screen. 2. Contact Hobart Service. |

SERVICE

Contact your local Hobart-authorized service office for any repairs or adjustments needed on this equipment.