

HOBART

INSTRUCTION MANUAL

... with Replacement Parts

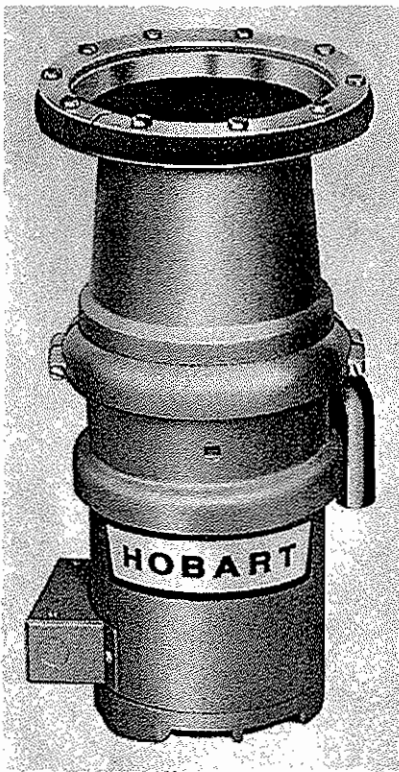

MODELS FD-50, FD-75 & FD-125 FOOD WASTE DISPOSERS

(INCLUDES MOTOR PARTS)

ML-18972 FD-50
ML-18973 FD-75
ML-18974 FD-125

Installation, Operation and Care of MODELS FD-50, FD-75 & FD-125 FOOD WASTE DISPOSERS

A. DESIGN:

The model FD food waste disposers utilize steel cutter blocks (1, Fig. 1) mounted to a rotating flywheel (4, Fig. 1) and a stationary shredder ring (2, Fig. 1) to grind food waste to a small particle size for discharge through waste lines. With the motor running and flushing water turned on, food waste is reduced to grinding size by the rotating "hi-bulk" cutter (3, Fig. 1). Grinding occurs as the food waste is forced against the shredder ring by the cutter blocks and the centrifugal force due to rotation. The flushing water aids the grinding action and discharges ground food waste into the waste line.

The disposer features removable hardened steel components, reversible rotation with grinding in both directions and a manual reset inherent overload protector in the motor circuit. It is self-feeding, making it unnecessary to force the food waste into the grinding mechanism. It may be

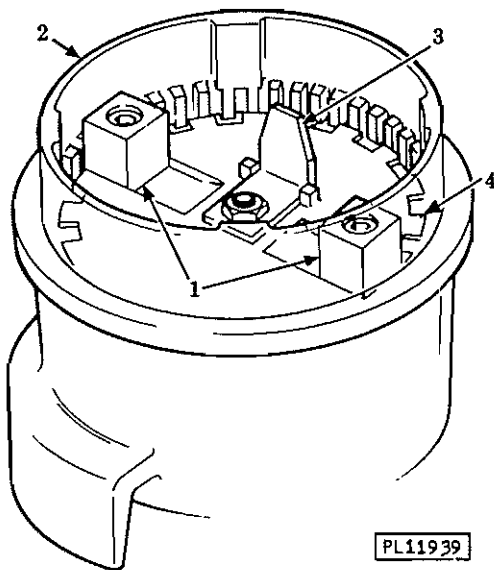

Fig. 1

completely filled with waste when idle, and will start and operate at full-load.

Control groups and accessory groups are available to suit each installation.

B. INSTALLATION:

Plumbing and electrical connections should be made by qualified workmen who will observe all Sanitary and Safety Codes, both National and Local.

Temporary support such as blocking must be provided for the disposer during installation to avoid excessive stress at welded or soldered cone to table connection.

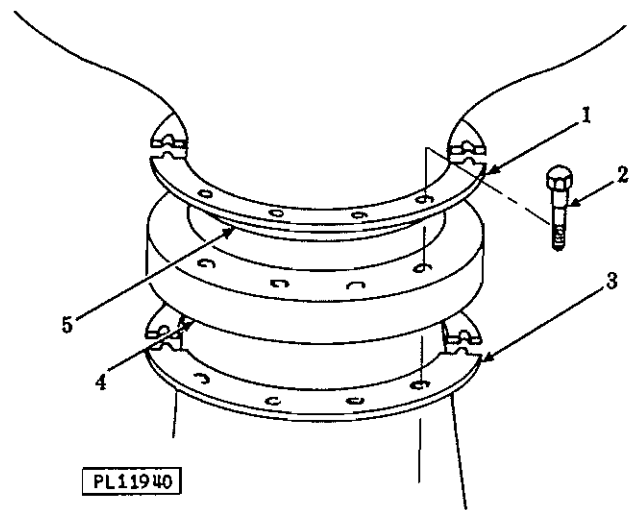

Fig. 2

1. ASSEMBLY:

To attach the disposer assembly to the cone for a regular duty installation (see Fig. 2). Note the top clamp ring (1, Fig. 2) has drilled holes and the bottom clamp ring (3, Fig. 2) has threaded holes. Using five screws (2, Fig. 2) assemble rear

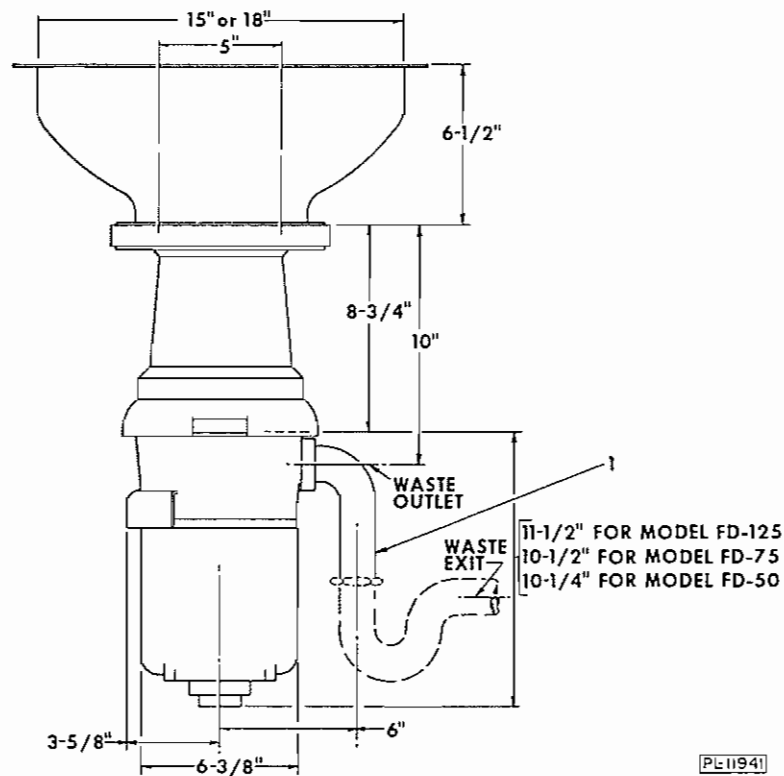

Fig. 3

halves of clamp rings to the back of the disposer flange (4, Fig. 2). Lift the disposer into position on the cone flange (5, Fig. 2) and assemble front halves of clamp rings using remaining five screws. Tighten all screws finger tight. Rotate disposer to desired position and tighten all screws evenly to form a water tight joint.

To install accessory group E (sink adapter for 3-1/2" to 4" sink opening), use the short upper housing. See (3, Fig. 4) and the accessory group data sheet.

2. DRAIN:

The disposer is furnished with a 1-1/2" O.D. waste discharge spout suitable for connection to a standard trap. Install waste lines with the shortest possible run and best fall. The waste exit must not be higher than center line of the waste outlet (1, Fig. 3 and 1, Fig. 4). Old waste lines must be thoroughly cleaned. Ream burrs from cut pipe ends and use fittings which will permit unrestricted flow.

NOTE: Drum traps and grease traps must NOT be used.

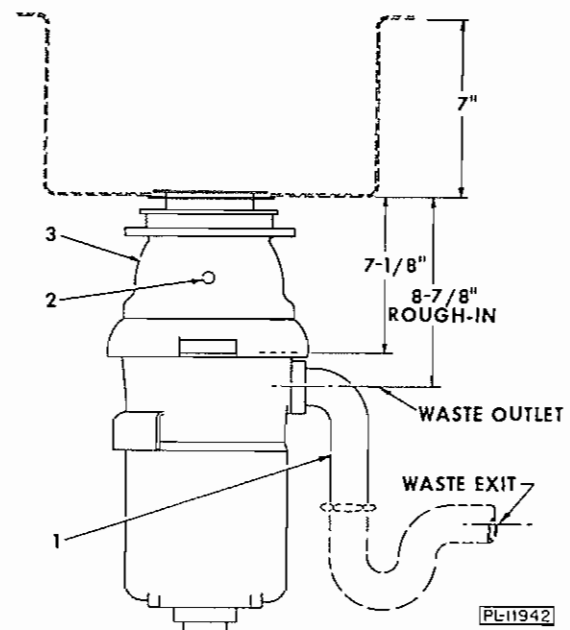

Fig. 4

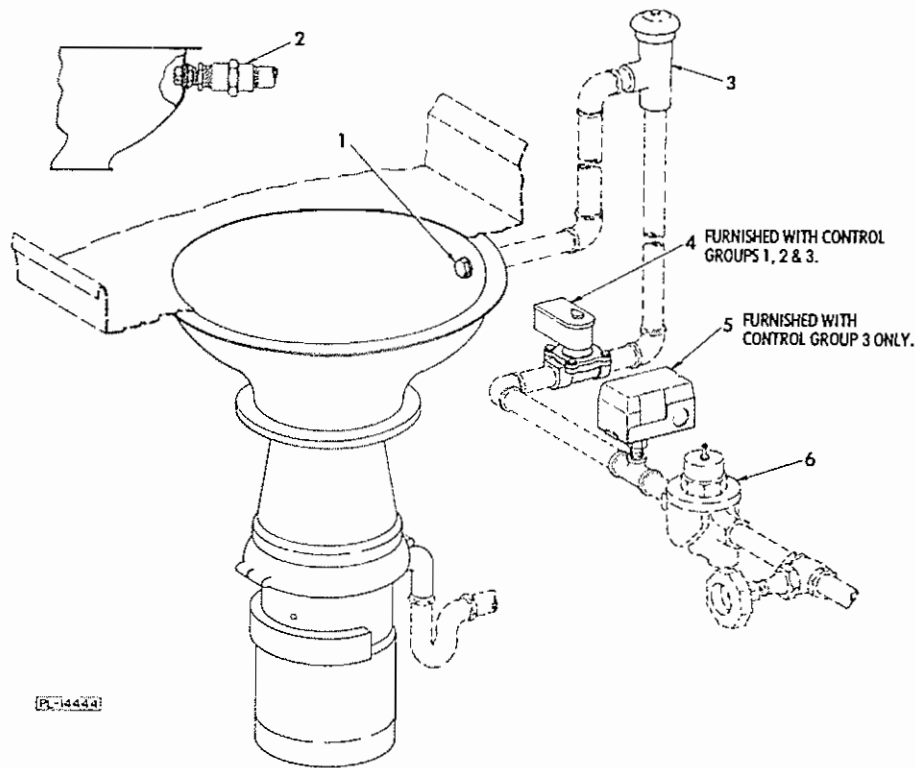

Fig. 5

3. WATER CONNECTIONS:

Connect disposer at (2, Fig. 4 or 1, Fig. 5) from a 3/4" i.p.s. cold water supply line. Install the five gallon per minute flow control (2, Fig. 5) supplied with the disposer at (2, Fig. 4 or 1, Fig. 5). If the water line pressure exceeds 60 p.s.i., a pressure reducing valve (6, Fig. 5) (not supplied) should be installed. The minimum flow pressure for the disposer to function properly is 16 p.s.i. Install a shut-off valve (not supplied) for proper servicing of the disposer.

All control groups are supplied with a solenoid valve (4, Fig. 5 or 3, Fig. 6) which must be installed in the water supply line as shown. Control Group 3 is furnished with a pressure switch (5, Fig. 5 or 4, Fig. 6) which must be installed between the solenoid valve and pressure reducing valve. If there is no pressure reducing valve in the water supply line, then install the pressure switch between the solenoid and the shut-off valve.

Install a vacuum breaker (3, Fig. 5) according to local plumbing codes. If local plumbing codes prohibit the use of a vacuum breaker, install an air gap water inlet (2, Fig. 6) (not supplied) observing the local codes.

4. ELECTRICAL CONNECTIONS:

Before making any electrical connections,

disconnect electrical power. CHECK THE SPECIFICATIONS ON THE NAME PLATE TO MAKE SURE THEY AGREE WITH THOSE OF YOUR ELECTRICAL SERVICE.

The disposer must be properly grounded before operating by connecting the machine to a suitable ground. Wiring must conform to National Electrical Code, (N.E.C.), #70, 1971 SEC 250-57 and/or all applicable local electrical codes.

Knockouts are provided in the motor junction box for making electrical connections to the unit. Flexible conduit should be used to permit moving the unit for periodic servicing and maintenance.

Select and follow wiring diagram furnished with machine applicable to your disposer and type of electrical service.

C. OPERATION:

Before operating disposer make sure it is clear of foreign objects such as metal or wire clippings, screws, nails, etc. which may have dropped into it during installation. Check the flywheel for free rotation.

CAUTION: NEVER USE YOUR HAND TO CHECK ROTATION OF FLYWHEEL OR TO REMOVE FOREIGN MATTER FROM THE DISPOSER. Use a stick or similar object to turn

the flywheel. Foreign matter can be removed with tongs or pliers.

Start disposer before feeding food waste. Be sure water is flowing. (With typical optional controls, water flow and unit starting are simultaneous and automatic). Feed food waste into disposer. Do NOT feed china, metal, rags, clam shells or similar material into the unit. Do NOT put grease or oil in disposer as drain may become clogged. Always allow the disposer to run for a short period after grinding is completed to assure proper flushing of the disposer and waste line. This flushing is automatically controlled with certain optional controls.

D. CONTROLS:

The operation of the disposer and additional available controls will be dependent on the selection of control devices. Refer to control group data sheet.

E. CLEANING:

The food waste disposer should be kept in a clean and sanitary condition. Allow the disposer to run a few moments after disposing of all food waste, to completely flush out the interior.

If food waste is allowed to accumulate due to improper clean up, it will give off offensive odors. If this happens, cleaning can be accomplished by using a stiff brush with strong soap and hot water solution. Light cleaning can be accomplished by grinding ice and a lemon through the disposer.

CAUTION: DO NOT USE CHEMICAL SOLVENTS OR OTHER DRAIN CLEANING COMPOUNDS THROUGH THIS DISPOSER.

NEVER REACH INSIDE THIS DISPOSER WHILE IT IS OPERATING.

F. MAINTENANCE:

1. LUBRICATION:

No lubrication is required for the food waste disposer unit.

2. CUTTER BLOCKS:

The cutter blocks (1, Fig. 1) may be rotated by a qualified service technician if the cutting edges become worn.

G. GENERAL:

1. OVERLOAD PROTECTION:

The disposer motor is protected by a thermal, resettable circuit breaker and will trip if the motor is overloaded. To reset, allow approximately five minutes for cooling, then press the manual reset button located on the bottom of the motor. An arrow on the side of the motor indicates location of the button. Restart the disposer using normal operating procedure. If circuit breaker continues to trip, contact a serviceman for assistance.

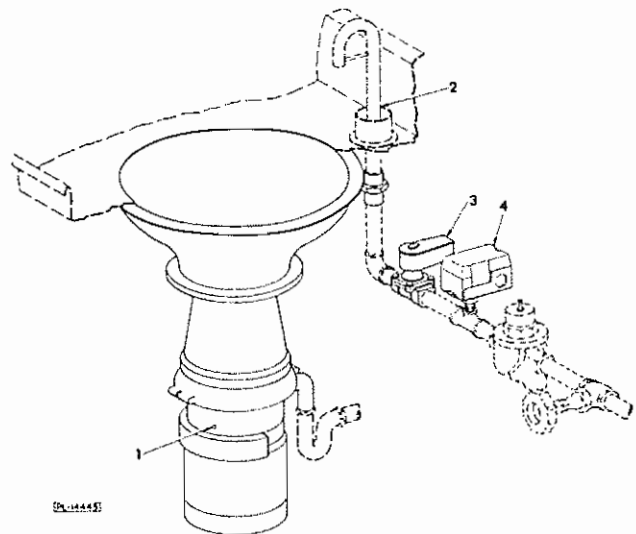

Fig. 6

2. WATER SEAL VENT:

A small weep hole (1, Fig. 6) in the side of the lower housing vents the dry side of the water seal. Water leaking from this weep hole is an indication of water seal leakage. If leaking, the water seal should be replaced. Do NOT plug or put grease in the weep hole.

3. OPERATING TIPS:

In the event of a malfunction of the disposer, refer to the service tips section to attempt to locate the trouble. If satisfactory operation is not obtained, contact your local authorized Hobart Sales and Service office for assistance.

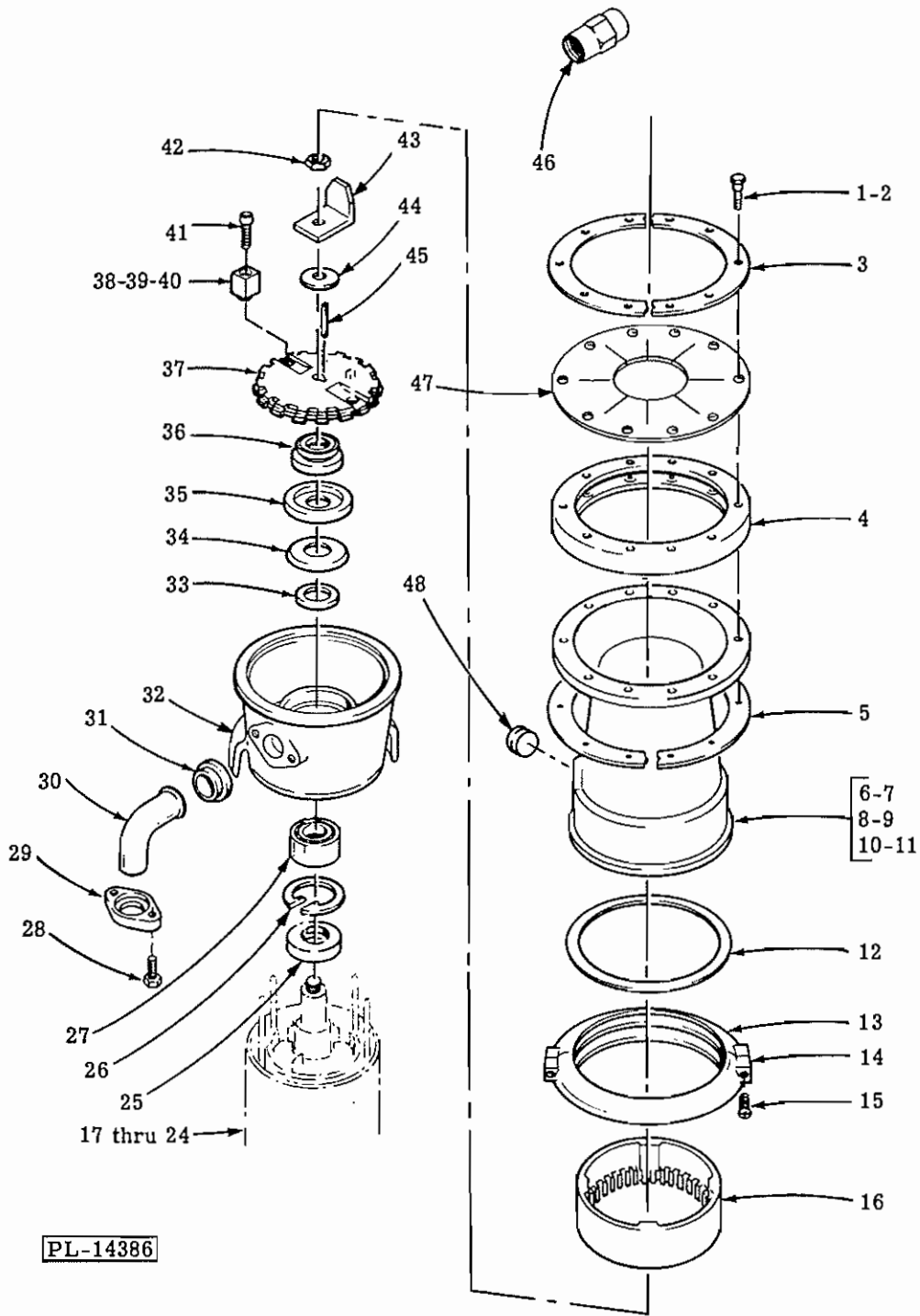

DISPOSER UNIT

DISPOSER UNIT

ILLUS. PL-14386	PART NO.	NAME OF PART	AMT.
1	SC-90-18	Fin. Bolt - 1/4"-20 x 1-3/8" Hex Hd. (Use with item #6)	10
2	SC-36-22	Fin. Bolt - 5/16"-18 x 7/8" Hex Hd. (Use with items #7, 8, 9, 10 or 11)	AR
3	B-203185	Ring - Top Cone Clamp (Half)	2
4	C-201492	Ring - Isolating	1
5	B-203191	Ring - Bottom Cone Clamp (Half)	2
6	D-200958	Housing - Upper (8-1/8" High, 8-1/16" Bolt Circle, 8-11/16" O.D. Flange)	1
7	D-200921-1	Housing - Upper (8-1/8" High, 5-1/2" Bolt Circle, 6-11/16" O.D. Flange)	1
8	D-200921-2	Housing - Upper (8-1/8" High, 6" Bolt Circle, 6-11/16" O.D. Flange)	1
9	D-200921-3	Housing - Upper (8-1/8" High, 5-1/2" Bolt Circle, 6" O.D. Flange)	1
10	D-200961-2	Housing - Upper (5-1/2" High, 4-1/2" Bolt Circle, 6-7/8" O.D. Flange)	1
11	D-200923	Housing - Upper (5" High, 5-1/2" Bolt Circle, 6-5/8" O.D. Flange)	1
12	B-201501	Gasket	1
13	C-203182	Ring - Clamp (Rear)	1
14	C-203181	Ring - Clamp (Front)	1
15	SC-12-88	Mach. Screw - 1/4"-20 x 1-3/4" Fil. Hd.	2
16	C-201227	Ring - Shredder	1
17	D-117112-1	Motor (115/200/230 V., 60 Hz., 1 Ph.) (FD-50 & FD-75) (Give Elec. Spec.)	1
18	D-117519	Motor (115/220 V., 50 Hz., 1 Ph.) (FD-50 & FD-75) (Give Elec. Spec.)	1
19	D-117113-1	Motor (200/230/460 V., 60 Hz., 3 Ph.) (FD-50 & FD-75) (Give Elec. Spec.)	1
20	D-117518	Motor (220-240/380-415 V., 50 Hz., 3 Ph.) (FD-50 & FD-75) (Give Elec. Spec.)	1
21	D-117108-1	Motor (115/200/230 V., 60 Hz., 1 Ph.) (FD-125) (Give Elec. Spec.)	1
22	D-117517	Motor (115/220 V., 50 Hz., 1 Ph.) (FD-125) (Give Elec. Spec.)	1
23	D-117109-1	Motor (200/230/460 V., 60 Hz., 3 Ph.) (FD-125) (Give Elec. Spec.)	1
24	D-117516	Motor (220-240/380-415 V., 50 Hz., 3 Ph.) (FD-125) (Give Elec. Spec.)	1
25	A-201448	Seal - Oil	1
26	RR-8-15	Ring - Retaining	1
27	BB-9-47	Ball Bearing - Fag #3303	1
28	SC-36-22	Fin. Bolt - 5/16"-18 x 7/8" Hex Hd.	2
29	B-200731	Flange - Spout	1
30	A-203401	Spout - Waste	1
31	B-201404	Gasket - Spout	1
32	E-117151	Housing - Lower	1
33	A-202717	Spacer - Shaft	1
34	A-202725	Slinger - Water	1
35	A-203194	Support - Seal	1
36	C-117071	Water Seal Assy.	1
37	C-201250-1	Flywheel	1
38	B-201223-3	Cutter - Flywheel (FD-50)	2
39	B-201223-1	Cutter - Flywheel (FD-75)	2
40	B-201223-4	Cutter - Flywheel (FD-125)	2
41	B-202556-1	Screw	2
42	NS-31-39	Stop Nut - 1/2"-20 "Elastic"	1
43	A-201235	Cutter - Hi-Bulk	1
44	A-201484	Seal - Shaft	1
45	A-203619	Key - Shaft	1
46	A-201721-1	Flow Control (5 G.P.M.)	1
47	B-202105	Guard - Splash (8-1/16" Bolt Circle) (Use with item #6)	1
48	FP-66-2	Plug - 1/2" Sq. Hd. Pipe	1
	B-200366	Upper Housing & Shredder Ring Assy. (Incls. items #6, 16 & 48)	1
	B-200235-1	Upper Housing & Shredder Ring Assy. (Incls. items #7 & 16)	1
	B-200235-2	Upper Housing & Shredder Ring Assy. (Incls. items #8 & 16)	1
	B-200235-3	Upper Housing & Shredder Ring Assy. (Incls. items #9 & 16)	1
	B-200392	Upper Housing & Shredder Ring Assy. (Incls. items #10, 16 & 48)	1
	B-200293	Upper Housing & Shredder Ring Assy. (Incls. items #11, 16 & 48)	1
	A-200541	Upper Housing, Isolating Ring & Shredder Ring Assy. (Incls. items #1, 3, 4, 5, 6, 16 & 48)	1
	A-200432	Seal and Bearing Kit (Incls. items #25, 27, 33, 34, 35, 36, 42 & 44)	1

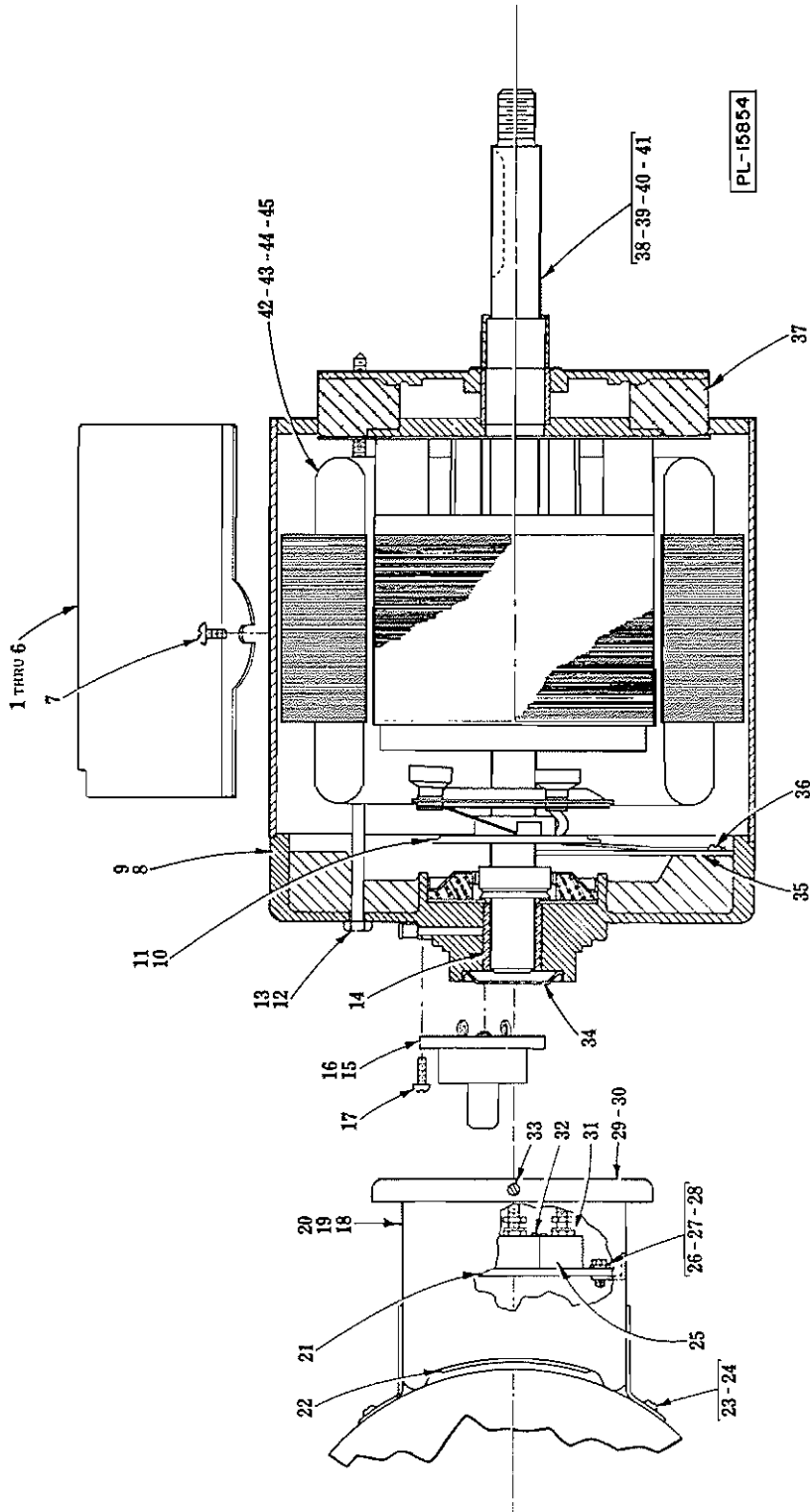

MOTOR UNIT (1 PH.)

MOTOR UNIT (1 PH.)

ILLUS. PL-15854	PART NO.	NAME OF PART	AMT.
	1	C-117114-1 Housing - Capacitor (FD-50 & FD-75)	1
	2	C-117114-2 Housing - Capacitor (FD-125)	1
**3	C-117531-2	Gasket - Capacitor Housing (FD-50 & FD-75)	1
**4	C-117531-1	Gasket - Capacitor Housing (FD-125)	1
	5	B-117056-1 Capacitor (FD-50 & FD-75)	1
	6	B-117056-2 Capacitor (FD-125)	1
	7	SD-9-20 Self-Tapping Screw - #10-32 x 5/16" Bind. Hd., Type F	2
*8	C-117055-1	Bearing Bracket Assy. (Incls. items #14, 34, 35 & 36)	1
**9	C-117102-1	Bearing Bracket Assy. (Incls. items #14, 34, 35 & 36)	1
*10	B-117138	Switch - Rotating	1
**11	B-117555	Switch - Rotating	1
	12	SC-110-83 Mach. Screw - #10-32 x 7-5/8" Ind. Hex Hd. (FD-50 & FD-75)	4
	13	SC-110-84 Mach. Screw - #10-32 x 8-1/8" Ind. Hex Hd. (FD-125)	4
	14	A-202924 Bearing - Sleeve	1
*15	B-117146-1	Protector - Thermal (FD-50 & FD-75)	1
*16	B-117146-2	Protector - Thermal (FD-125)	1
*17	SD-9-24	Self-Tapping Screw - #6-32 x 3/8" Rd. Hd., Type F	2
**18	D-113403	Box - Terminal	1
*19	C-117115	Box - Terminal	1
*20	SD-9-20	Self-Tapping Screw - #10-32 x 5/16" Bind. Hd., Type F (Box to Motor)	2
**21	B-117514	Base Plate - Terminal Box	1
**22	M-60395	Grommet	1
**23	SD-15-27	Self-Tapping Screw - #10-24 x 5/16" Pan Hd. "Taptite"	2
**24	WL-7-12	Lock Washer - #10 Ext. Shakeproof	2
**25	B-116793-1	Terminal Block Assy. (Incls. item #31)	1
**26	SD-14-9	Self-Tapping Screw - #8-32 x 5/16" Pan Hd., Type 1	2
**27	A-202559	Screw - Grounding	1
**28	WL-7-11	Lock Washer - #10 Ext. Shakeproof	1
**29	B-113405	Cover - Terminal Box	1
**30	B-114811	Gasket - Terminal Box Cover	1
**31	A-118028	Strap - Jumper	AR
**32	SC-60-5	Mach. Screw - #10-32 x 5/8" Rd. Hd	2
**33	SD-14-9	Self-Tapping Screw - #8-32 x 5/16" Pan Hd., Type 1	2
	34	A-201928 Retainer - Grease	1
	35	B-117142 Switch - Stationary	1
	36	SC-9-82 Mach. Screw - #8-32 x 5/16" Rd. Hd	2
	37	B-117137 Fan	1
*38	D-117135-1	Rotor Assy. (115/200/230 V.) (FD-50 & FD-75) (Incls. items #10 & 37)	1
*39	D-117131-1	Rotor Assy. (115/200/230 V.) (FD-125) (Incls. items #10 & 37)	1
**40	D-117135-2	Rotor Assy. (115/220 V.) (FD-50 & FD-75) (Incls. items #11 & 37)	1
**41	D-117131-2	Rotor Assy. (115/220 V.) (FD-125) (Incls. items #11 & 37)	1
*42	D-117133-1	Stator Assy. (115/200/230 V.) (FD-50 & FD-75)	1
*43	D-117132-1	Stator Assy. (115/200/230 V.) (FD-125)	1
**44	D-117133-3	Stator Assy. (115/220 V.) (FD-50 & FD-75)	1
**45	D-117132-3	Stator Assy. (115/220 V.) (FD-125)	1
	**C-117513-1	Terminal Box Assy. (Incls. items #18, 21, 22, 25, 26, 27, 28 & 32)	1

*60 Hz.

**50 Hz.

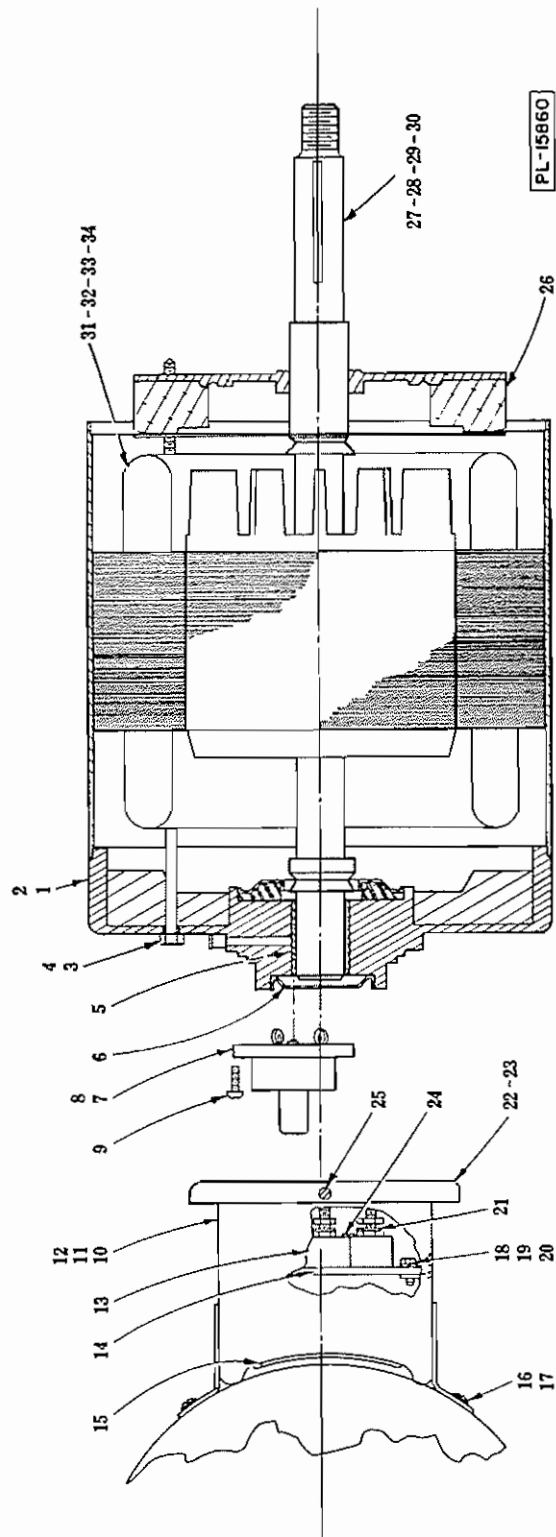

MOTOR UNIT (3 PH.)

MOTOR UNIT (3 PH.)

ILLUS. PL-15860	PART NO.	NAME OF PART	AMT.
*1	C-117055-2	Bearing Bracket Assy. (Incls. items #5 & 6)	1
**2	C-117102-2	Bearing Bracket Assy. (Incls. items #5 & 6)	1
3	SC-110-83	Mach. Screw - #10-32 x 7-5/8" Ind. Hex Hd. (FD-50 & FD-75)	4
4	SC-110-84	Mach. Screw - #10-32 x 8-1/8" Ind. Hex Hd. (FD-125)	4
5	A-202924	Bearing - Sleeve	1
6	A-201928	Retainer - Grease	1
*7	B-117146-3	Protector - Thermal (FD-50 & FD-75)	1
*8	B-117146-4	Protector - Thermal (FD-125)	1
*9	SD-9-24	Self-Tapping Screw - #6-32 x 3/8" Rd. Hd., Type F	2
**10	D-113403	Box - Terminal	1
*11	C-117115	Box - Terminal	1
*12	SD-9-20	Self-Tapping Screw - #10-32 x 5/16" Bind. Hd., Type F (Box to Motor)	2
**13	B-116793-2	Terminal Block Assy. (Incls. item #21)	1
**14	B-117514	Base Plate - Terminal Box	1
**15	M-60395	Grommet	1
**16	SD-15-27	Self-Tapping Screw - #10-24 x 5/16" Pan Hd. "Taptite"	2
**17	WL-7-12	Lock Washer - #10 Ext. Shakeproof	2
**18	SD-14-9	Self-Tapping Screw - #8-32 x 5/16" Pan Hd., Type 1	2
**19	A-202559	Screw - Grounding	1
**20	WL-7-11	Lock Washer - #10 Ext. Shakeproof	1
**21	A-118028	Strap - Jumper	AR
**22	C-113405	Cover - Terminal Box	1
**23	B-114811	Gasket - Terminal Box Cover	1
**24	SC-60-5	Mach. Screw - #10-32 x 5/8" Rd. Hd.	2
**25	SD-14-9	Self-Tapping Screw - #8-32 x 5/16" Pan Hd., Type 1	2
26	B-117137	Fan	1
*27	D-117136-1	Rotor Assy. (200/230/460 V.) (FD-50 & FD-75) (Incls. item #26)	1
*28	D-117129-1	Rotor Assy. (200/230/460 V.) (FD-125) (Incls. item #26)	1
**29	D-117136-2	Rotor Assy. (220-240/380-415 V.) (FD-50 & FD-75) (Incls. item #26)	1
**30	D-117129-2	Rotor Assy. (220-240/380-415 V.) (FD-125) (Incls. item #26)	1
*31	D-117134-1	Stator Assy. (200/230/460 V.) (FD-50 & FD-75)	1
*32	D-117130-1	Stator Assy. (200/230/460 V.) (FD-125)	1
**33	D-117134-3	Stator Assy. (220-240/380-415 V.) (FD-50 & FD-75)	1
**34	D-117130-3	Stator Assy. (220-240/380-415 V.) (FD-125)	1
**C-117513-2		Terminal Box Assy. (Incls. items #10, 13, 14, 15, 18, 19, 20 & 24)	1

*60 Hz.

**50 Hz.

SERVICE TIPS

CONDITION	CAUSE	REMEDY (ALWAYS disconnect electrical power from disposer).
Motor will not start.	Blown fuse.	Check circuit fuse.
	Improper wiring installation.	Check and follow wiring diagram.
	Overload protector tripped.	Correct cause of overload, repress start button.
	Cutter jammed.	Remove obstruction.
	Defective stator winding.	Repair or replace stator.
	Defective control component.	Repair or replace.
Water supply insufficient.	Improper supply size.	Use 3/4" i.p.s. feed line and valve.
	Low-water pressure.	Increase pressure to 16 p.s.i. flow pressure.
	Defective Dole flow regulator.	Replace. Should give 5 gal. per min. at 16 p.s.i. flow.
Water continues to flow.	Defective valve.	Service or replace.
Water does not flow.	Defective valve.	Service or replace.
Water flowing from weep hole.	Defective water seal.	Replace seal.
Drain stoppage.	Worn cutting parts.	Service replacement may be required.
	Undersize drain.	Use 1-1/2" or larger.
	Insufficient fall.	1/4" fall per ft.
Reduced Operating performance.	Broken or worn shredder ring.	Replace ring.
	Excessively worn cutter blocks.	Rotate or replace cutter blocks.
	Clogged shredder ring apertures.	Clean.