



INSTRUCTION MANUAL

C-LINE DISHWASHERS

C-44	CRS-66	CPW-80
C-54	CRS-76	CPW-90
C-64	CRS-86	CPW-100
C-81	CRS-103	CPW-117

INSTALLATION, OPERATION and CARE of C-Line Dishwashers

Save These Instructions

GENERAL

DESIGN

The C-Line dishwashers are fully automatic, rack-type machines. They feature front inspection doors which provide ready access to interior of wash chamber. One and two tank machines are available, and may be ordered with a Prewash Unit or Recirculating Scrapper. Although C-Line dishwashers may be ordered with various lengths and accessories, these instructions cover all machines.

CONTROLS

Operational control switches: Heat ON-OFF; Pumps RUN-OFF; and Auto Fill START (optional) are housed in control boxes. The boxes also house motor protector overload relays. A reducing voltage transformer is furnished for electrical power supply voltage above 250 V.A.C. This transformer supplies a reduced voltage to control circuit of the motor controller and its associated components. The optional Auto Timer control box is shipped separately and must be remotely mounted.

MOTOR AND PUMP UNITS

Motors are Hobart built, which operate NI - Resist impeller pumps. The wash motor provides movement of the dish racks through the machine. On machines with power rinse, the right-hand motor provides rack movement.

VACUUM BREAKERS

The fill lines for the wash and rinse tanks, and the final rinse line incorporate atmospheric vacuum breakers. These prevent any reverse flow of water from the dishwasher into the potable (fresh) water supply.

HEATER PROTECTION

A float is located in the wash and rinse tanks to automatically turn off the heat supply if the water

level is too low. Once the water level returns to a safe level, the heating circuit is operational if heat is demanded.

DOOR INTERLOCKS

To prevent the machine operation while an inspection door is open, interlock switches are provided. If, while the machine is operating, a door is opened, the pumps will automatically turn off. To restart pumps, close door.

On machines equipped with optional Auto Timer, if the AUTO-MANUAL switch is on MANUAL, the machine will restart after the door is closed. If the switch is on AUTO and the door is left open long enough for timer to run out, machine must be restarted by starting another rack through machine.

RS UNIT

22" Recirculating Scrapper — Power prewash unit which uses overflow water from the power wash tank and final rinse water. No fill valve is required.

PW UNIT

36" Prewash — Large power prewash unit which uses overflow water from the power wash tank and final rinse water. No fill valve is required.

OPTIONAL EQUIPMENT

Auto Fill — Separate switch automatically fills machine.

Auto Timer — Designed to save electrical power, the Auto Timer can be set to shut off pump motor(s) and exhaust vent fan after last rack exits dishwasher.

Blower Dryer — Dishes are dried by forced heated air.

Common Drain — Connects the dishwasher and prewash drains together, thus requiring only one drain connection at installation.

C-LINE INSTRUCTIONS

Condenser — Removes excess moisture from exhaust air and returns air to dish room.

Half Rack Unit — With the special cradle unit it is possible to index standard (20" x 20") and shorter than standard (10" x 20", 14" x 20" and 16" x 20") racks.

Extended Hood — Provides a dampered vent along with being an effective splash shield for the discharge end of the wash chamber.

Front Panel and Leg Trim — Stainless steel panels conceal pumps and plumbing.

Side Loader — Allows machine to be placed in a corner or used where area at the load end is limited. Available with or without hood.

Vent Hood — A dampered exhaust opening (sides are not as long as the extended hood) controls steam and water splash to work area.

INSTALLATION

CAUTION: Electrical and plumbing connections must be made by qualified workmen who will comply with the applicable portions of the National Electrical Code and/or other local electrical, sanitary, safety and plumbing codes.

After unpacking dishwasher, remove shipping plates. Plug holes in the adjustable feet with plastic plugs (packed in bag attached to drain handle). Set the dishwasher in its proper location, adjust the height and level by turning the threaded feet (11, Fig. 1). **NOTE:** The dishwasher must be positioned and leveled before making plumbing connections.

Dish table (2, Fig. 2) should be turned down and fit into the dishwasher (1, Fig. 2). Use Mastic between table and lip of tank to prevent leakage. Rack track height should be from 1/8" to 3/16" (dim. A, Fig. 2) above the tank lip.

PLUMBING

The plumber who connects this machine is responsible for making certain that both water and steam lines are **THOROUGHLY FLUSHED OUT BEFORE** connecting to any manual valve or solenoid valve.

This "flush-out" is necessary to remove from the lines all foreign matter such as chips (resulting from cutting or threading of pipes), pipe joint compound, or, if soldered fittings are used, bits of solder or cuttings from the tubing. Debris, if not removed, may lodge in these valves and render them inoperative.

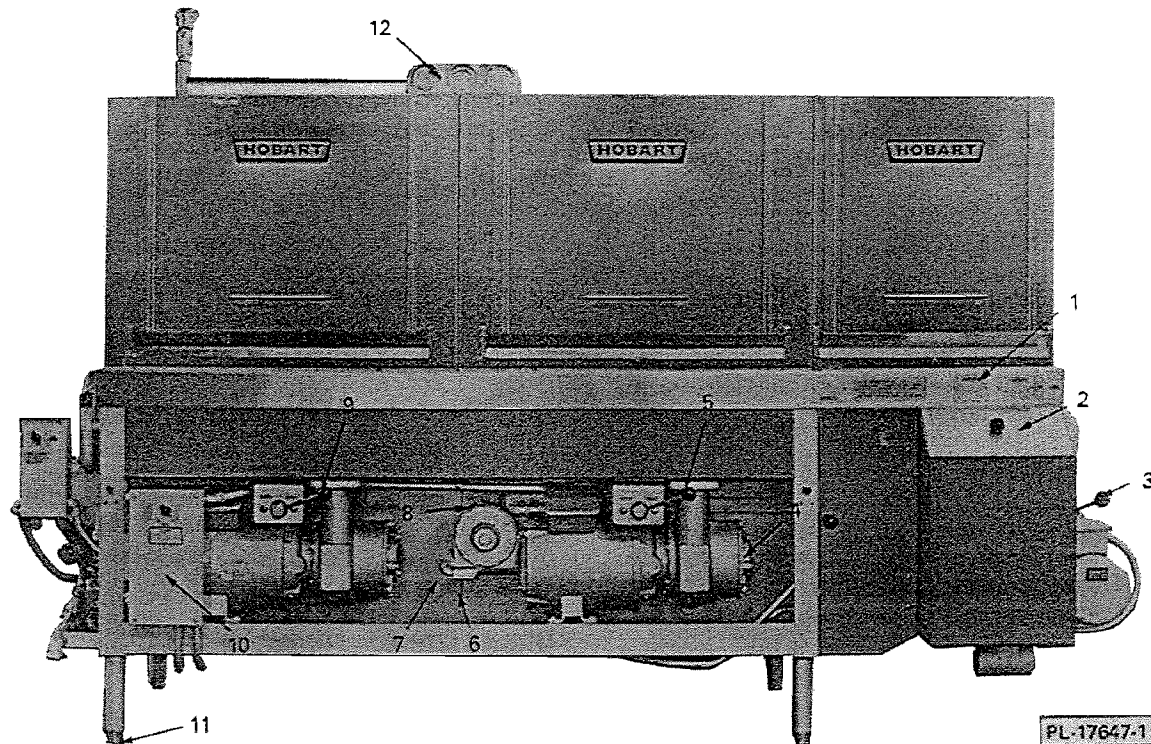

Fig. 1

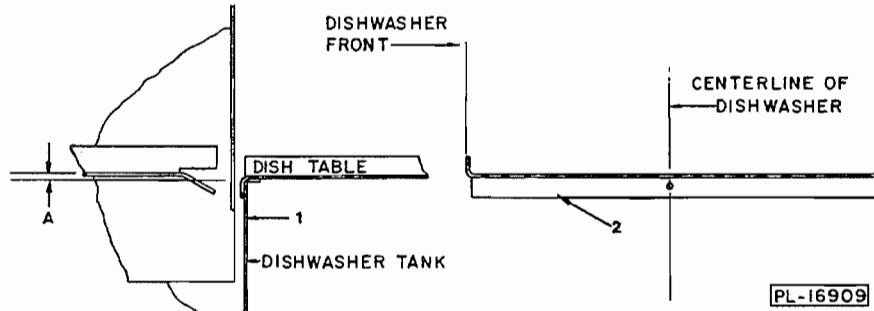

Fig. 2

Manual valves or solenoid valves, fouled by foreign matter and any expenses resulting from this fouling, are NOT the responsibility of the manufacturer.

Drain

Connect the drain(s) to the sewer using 2" pipe. Single tank machines require a separate 3/4" drain from the final rinse catch pan. Multi-tank machines with optional common drain have drains already connected, thus requiring only one connection to floor drain. If a grease trap is required by code, it should have a flow capacity of 38 gallons per minute.

Fill

A 1/2" fitting is provided for connecting the wash tank fill line (3, Fig. 3). This line fills the wash tank and prewash tank (RS or PW unit). On machines with power rinse, a separate 1/2" fitting (4, Fig. 4) is provided for connecting the power rinse tank fill line. The fill water temperature should be 10° to 160° F.

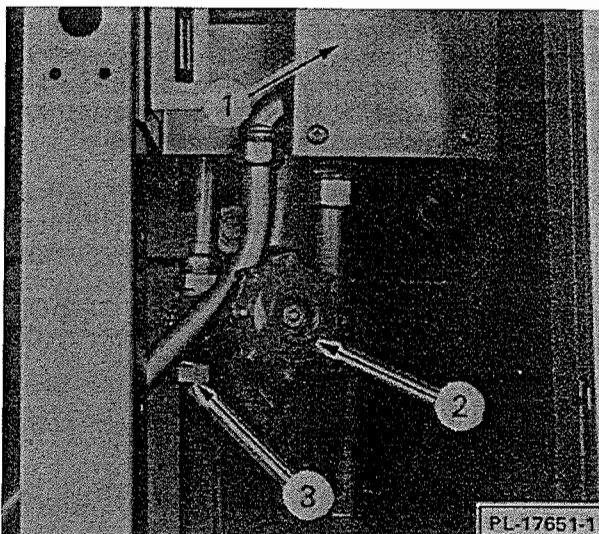

Fig. 3

Final Rinse

The line strainer, tee and flanged nipple are disassembled for shipping purposes. Reassemble this piping assembly, making sure the "O" ring is properly seated in the grooved flange. Screws, nuts and lock washers for attaching are in a cloth bag tied to the solenoid valve.

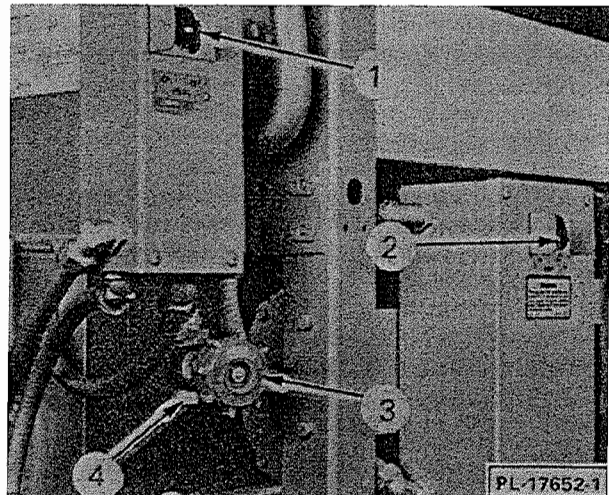

Fig. 4

Use 3/4" pipe for the connecting line. A flow pressure of 15 to 25 P.S.I. and a minimum temperature of 180° F. must be maintained at the machine. For long runs use larger pipe and insulation to assure adequate pressure and temperature. If flow pressure exceeds 25 P.S.I., a pressure reducing valve (not furnished) must be installed in the supply line.

Each machine is equipped with a pressure gauge to verify proper minimum pressure. After checking pressure, turn off pet cock as stated in instructions printed on the gauge.

Gas Heat

Check gas data plate attached to dishwasher or tag attached to gas burner tubing for type of gas to be used.

C-LINE INSTRUCTIONS

Connect gas burner to gas supply. Check gas burner compression fittings to assure they have not loosened during shipment.

A capped "tee" (not supplied) is recommended to catch loose particles in front of the valves.

The burner is not adjustable. If line pressure is above 7" W.C. (natural gas) or 11" W.C. (L.P. gas), an additional regulator valve (not supplied) must be installed in the supply line.

The pilot flame is intended to burn continuously. Should the flame go out or gas pressure fail, the valve will shut off completely, thus preventing any leakage into the room.

To light the gas pilot: open the gas shut-off valve (1, Fig. 5); open the lighter hole cover (3, Fig. 5); push and hold the reset button (2, Fig. 5) while holding flame inside the lighter hole; hold reset button for 30 to 45 seconds or until burner continues to burn when button is released. The pilot flame should surround end of thermocouple by 1/2".

Steam Heat

CAUTION: Steam supply pressure must agree with steam trap selection. The steam trap (supplied) will be either for 20 P.S.I. flowing and under or for 20-45 P.S.I. flowing.

The steam supply must be between 5 and 45 P.S.I. flowing pressure. If flowing pressure exceeds 45 P.S.I. a pressure regulator (not supplied) must be installed in the supply line.

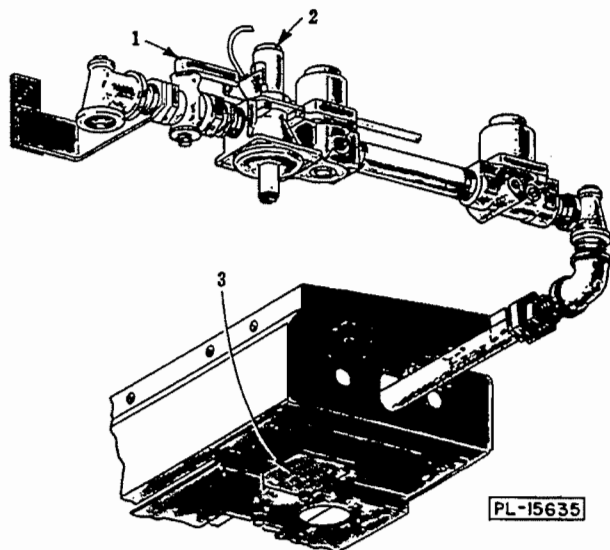

Fig. 5

If flowing pressure is under 10 P.S.I. use 3/4" piping; if over 10 P.S.I. use 1/2" piping. Steam flow is controlled by solenoid and mechanical globe valves.

If machine is equipped with steam injectors one connection per injector is required. For steam coil installations two connections per coil are required, one for supply and one for return.

ELECTRICAL CONNECTIONS

WARNING: DISCONNECT ELECTRICAL POWER SUPPLY AND PLACE A TAG AT DISCONNECT SWITCH, INDICATING CIRCUIT IS BEING WORKED ON.

NOTE: Machines equipped with electric heat may have more than one power supply. All supplies **MUST** be disconnected.

Before making any electrical connections, check the specifications on machine data plate (1, Fig. 1) to make sure they agree with your electrical power service. Most electrical codes (local, state or national) require the power circuit for the dishwasher to have a disconnecting device such as a fused disconnect switch (not supplied) for both the motor circuit and heat circuit. Make sure the installation complies with the code for your area.

Motor(s)

Connect a permanent electrical power supply to the incoming power supply block in the motor (pump) control box (10, Fig. 1). Three-phase motor(s) must rotate the impeller in the direction of the arrow found either on the motor or pump housing of the motor pump unit(s). Before placing the machine into service, a check must be made to verify correct rotation. If machine is equipped with more than one motor, only one need be checked as the machine is wired, at the time of manufacture, so all motors will rotate the same direction.

To verify motor rotation, remove the three hex head screws and face plate cover (4, Fig. 1) of the wash pump. The impeller is then plainly visible.

DO NOT PUT HANDS OR ANY FOREIGN OBJECT IN PUMP HOUSING WHILE THE FACE PLATE COVER IS REMOVED.

Energize the machine momentarily and check the impeller for direction of rotation.

If the impeller does not rotate in the direction of the arrow, **DISCONNECT POWER SUPPLY(IES)** to the machine and interchange any two power

supply leads at the incoming power supply block in the motor (pump) control box (10, Fig. 1). On machines with a circuit breaker box, reverse any two leads at the incoming power supply block in the circuit breaker box. Energize the machine momentarily and verify proper direction of rotation. Replace the face plate cover (4, Fig. 1) and the three hex head screws.

Electric Heat

DISCONNECT ELECTRICAL POWER SUPPLY(IES) and connect a permanent electrical power supply to the line terminals of the heat control box(es). The tank water temperature is regulated by a solid state thermostat which is preset at the factory and should not require adjustment. If an adjustment is necessary, contact your local Hobart Sales and Service Office. Use the machine thermometer (12, Fig. 1) for proper water temperature reading.

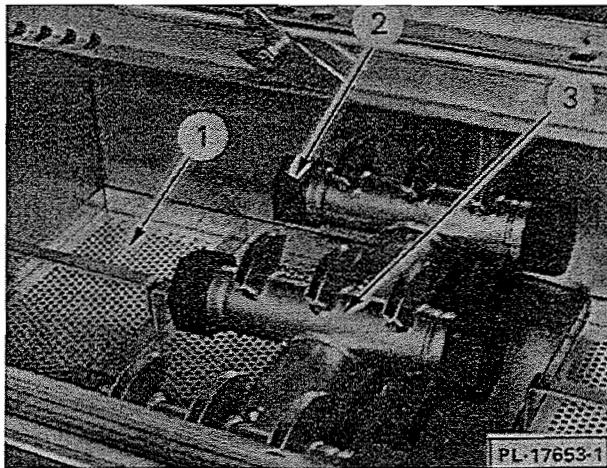

Fig. 6

OPERATION

PREPARATION

Put the dishwasher strainer pans (1, Fig. 6) into position in dishwasher tank(s).

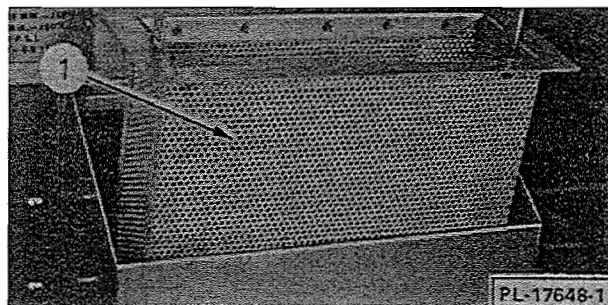

Fig. 7

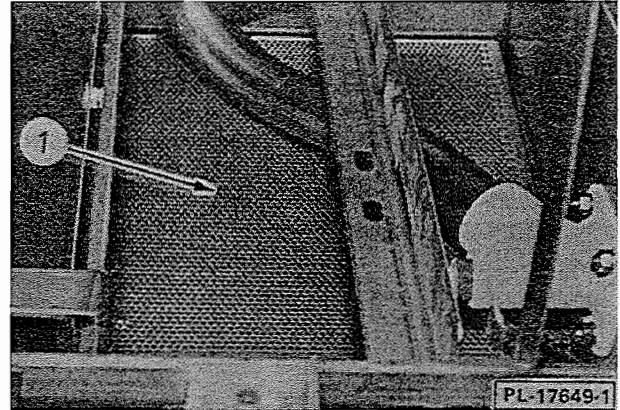

Fig. 8

If machine is equipped with RS or PW unit, lift prewash chute cover (2, Fig. 1) and install prewash strainer basket (1, Fig. 7). Replace chute cover. Place prewash screens (1, Fig. 8) (flange side down and lip forward) in position.

Hang curtains on open hooks provided. **NOTE:** See curtain diagram (Pages 11 & 12) that corresponds to your machine. A special entrance curtain is provided for machines equipped with the Side Loader option.

Move drain handle(s) (3, 5 & 9, Fig. 1) to SHUT to close drain(s). Turn heat switch(es) (1, Fig. 3 or 1, Fig. 4) ON. Open the fill valve(s) (2, Fig. 3 and/or 3, Fig. 4). If machine is equipped with optional Auto Fill, turn fill switch (1, Fig. 9) ON. The pumps should be left OFF until machine has completely filled.

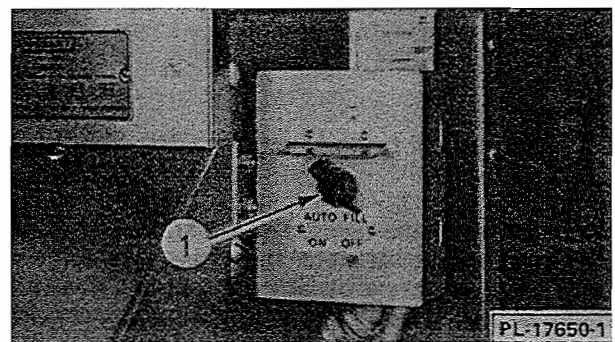

Fig. 9

NOTE: If machine is equipped with RS or PW unit, the prewash tank will fill last, from overflow water.

Heat

Turn heat switch(es) (1, Fig. 3 and/or 1, Fig. 4) ON. **NOTE:** If machine is equipped with steam heat the mechanical globe valve(s) must be opened.

C-LINE INSTRUCTIONS

The tank water temperature is regulated by the solid state thermostat. The thermostat is preset at the factory and no adjustment should be required. If an adjustment is necessary, contact your Hobart Sales and Service Office. Use thermometers (12, Fig. 1) for proper water temperature reading. The pilot lamp will remain lighted as long as the heat switch is turned ON. See chart for minimum tank temperatures.

	Wash	Power Rinse	Final Rinse
C-44	160°		180°
C-54	160°		180°
C-64	150°	160°	180°
C-81	150°	160°	180°
CRS-66	160°		180°
CRS-76	160°		180°
CRS-86	150°	160°	180°
CRS-103	150°	160°	180°
CPW-80	160°		180°
CPW-90	160°		180°
CPW-100	150°	160°	180°
CPW-117	150°	160°	180°

NOTE: If the tank is accidentally drained before turning off the heat switch, the float controlled low-water protector switch will automatically de-energize the tank heat. When the proper water level is returned, the tank heat will be automatically re-energized. **DO NOT** use the low water protection as a heat ON-OFF switch. The heat **MUST** be turned OFF at the control switch when machine is not in use.

Scatter the initial charge of detergent on the dishwasher strainer pans. Replenish as needed. When an automatic detergent dispenser has been added (by private supplier), follow supplier's instructions.

DISHWASHING

Start pumps by turning pump switch (2, Fig. 4) ON.

Stack dishes in the racks. Do not stack dishes one on top of another as water must have free access to both sides of every dish. Stand plates and dishes up edgewise as shown in Fig. 10. Cups, glasses, and bowls should be inverted in open-type or com-

partment-type rack as shown in Fig. 10. Silverware and other small pieces may be scattered loosely over the bottom of a flat bottom rack.

When one rack has been loaded, slide it into the machine and start loading another. The operation of the dishwasher is automatic; each rack moves through the prewash; wash and rinse zones, then out onto the clean dish table. The rinse lever is actuated by the dish rack and automatically shuts off the final rinse water when no rack is in the rinse zone.

Allow dishes to drain and air-dry before removing from rack.

NOTE: A spring loaded conveyor release is provided, should the racks jam or the load become excessive.

MAINTENANCE

WARNING: DISCONNECT ELECTRICAL SUPPLY, AND PLACE A TAG AT THE DISCONNECT SWITCH, INDICATING THE CIRCUIT IS BEING WORKED ON BEFORE BEGINNING ANY MAINTENANCE PROCEDURE.

NOTE: Machines equipped with electric heat may have more than one power supply. All supplies **MUST** be disconnected.

CLEANING

It is recommended that the machine be thoroughly cleaned at the end of each working shift or at least twice a day.

Procedure:

1. Turn Heat switch(es) OFF.
2. Open the doors.

NOTE: Standard door interlock switches prevent machine operation with inspection door(s) open.

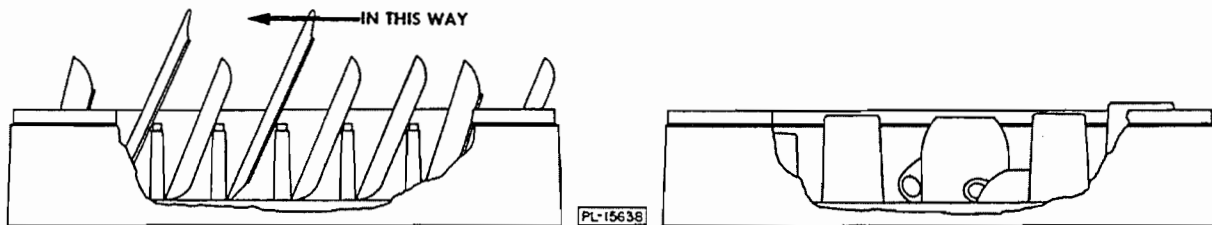

Fig. 10

3. Remove wash arms (3, Fig. 6); remove wash arm end caps (2, Fig. 6); using a common silverware knife, push any nozzle obstructions into the wash arms; thoroughly flush the wash arms in a sink; replace wash arm end caps (a twisting action helps assure proper seating).

NOTE: The optional lower prewash wash arm can be cleaned and flushed in the machine. Remove the end caps; dislodge any obstruction; close doors and briefly operate machine. Replace end caps.

4. Clean off any scraps from machine walls.
5. Clean dish tables into the dishwasher.
6. Lift off prewash chute cover (2, Fig. 1).
7. Remove all strainer pans, basket (where applicable). Empty contents into garbage can or disposer and thoroughly clean pans and basket.
8. Remove curtains. Thoroughly scrub, rinse and allow to dry at the end of each day's operation. See appropriate curtain diagram (Pages 11 & 12) for proper curtain installation.
9. Remove and clean overflow cap.
10. Open drain(s).
11. THOROUGHLY wash out the interior of the machine with a high pressure hose.
12. Return all strainer pans and basket (where applicable) to original locations.
13. Leave doors open and curtains removed while machine is not in use. This will allow the interior to air out and dry.

LUBRICATION

NOTE: Lists of acceptable lubricants are available through authorized Hobart Service Offices.

Speed reducer lubricant (supplied) should be replenished as needed. Check monthly, keeping lubricant level to top of elbow (7, Fig. 1). Each six months, remove plug (6, Fig. 1) and drain lubricant. Replace plug (6, Fig. 1). Refill until lubricant reaches top of elbow (7, Fig. 1) and replace elbow plug. Vent hole plug (8, Fig. 1) must be kept open for lubricant expansion. No other lubrication is required.

TROUBLESHOOTING

NOTE: If symptom persists after possible causes have been checked, contact an authorized Hobart Service Office.

SYMPTOM — No machine operation

POSSIBLE CAUSE:

1. Blown fuse or tripped circuit breaker at power supply.
2. Inspection door(s) not closed.
3. If machines ie equipped with Auto Timer, the timer may be expired.

SYMPTOM — Dishes not clean

POSSIBLE CAUSE:

1. Insufficient wash water due to drain obstruction preventing proper drain closing.
 2. Worn or torn drain "O" ring allowing wash water to drain.
 3. Wash arm nozzle obstruction.
 4. Loss of water pressure due to pump obstructions.
- DISCONNECT ELECTRICAL POWER SUPPLY(IES)** and place a tag indicating circuit is being worked on. Drain tanks and check for any obstruction at the pump intake.
5. Incorrect water temperature. Check circuit breaker to electric heat supply, or main steam valve. Make certain valve is completely open.
 6. Incorrect detergent dispensing. Contact your detergent representative.

SYMPTOM — Leaking valve (except solenoid type)

POSSIBLE CAUSE:

1. Foreign material preventing proper valve operation.

NOTE: A critical period is soon after installation when pipe compound or metal shavings may lodge at the valve seat. Shut off supply line. Unscrew and lift bonnet from valve body. Clean valve and reassemble.

C-LINE INSTRUCTIONS

2. If a solenoid valve is malfunctioning it is recommended that authorized Hobart Service personnel be contacted.

SYMPTOM – Spotting of silverware, glasses and dishes

POSSIBLE CAUSE:

1. Improperly loaded racks.
2. Incorrect final rinse water temperature (min. 180° F.).
3. Loss of water pressure due to pump obstruction.

DISCONNECT ELECTRICAL POWER SUPPLY and place a tag indicating circuit is being worked on. Drain tanks and check for any obstruction at the pump intake.

4. Excessively hard water.
5. Incorrect detergent for water type.
6. Misaligned rinse arms.

SYMPTOM – Inadequate rinse

POSSIBLE CAUSE:

1. Dirty line strainer causing reduced water flow. Turn off water supply, remove strainer cap, withdraw and clean screen. Reassemble.
2. Low supply line pressure.

SYMPTOM – Continuous rinse operation

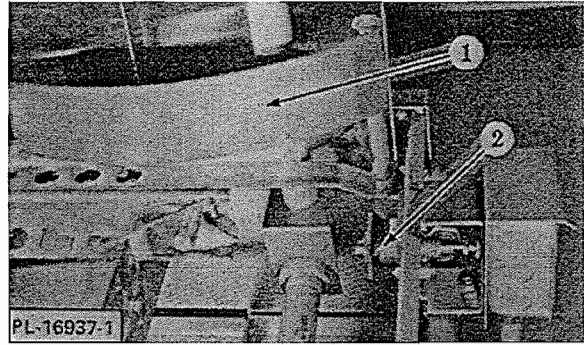

Fig. 11

POSSIBLE CAUSE:

1. Rinse lever (1, Fig. 11) not moving freely. **NOTE:** Turn machine off before checking lever for movement.
2. Improper plunger adjustment (2, Fig. 11) or micro switch not operating properly.

SYMPTOM – No wash tank heat

POSSIBLE CAUSE:

1. The machine is equipped with a low water safety device which shuts off heat if water level drops. Check for proper water level.
2. Circuit breaker to heat system tripped.
3. Steam valve not open completely.

SYMPTOM – No or slow fill

POSSIBLE CAUSE:

1. Dirty line strainer causing reduced water flow. Turn off water supply, remove strainer cap, withdraw and clean screen. Reassemble.

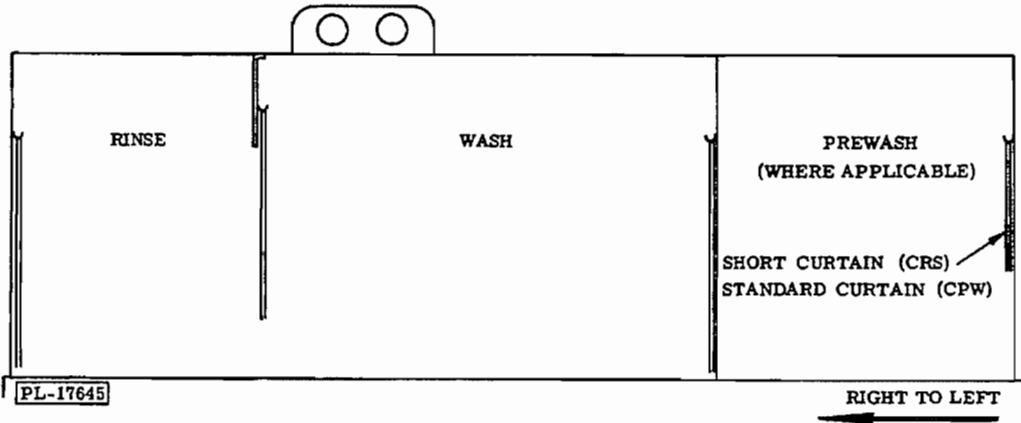

C-44 CRS-66 CPW-80
C-54 CRS-76 CPW-90

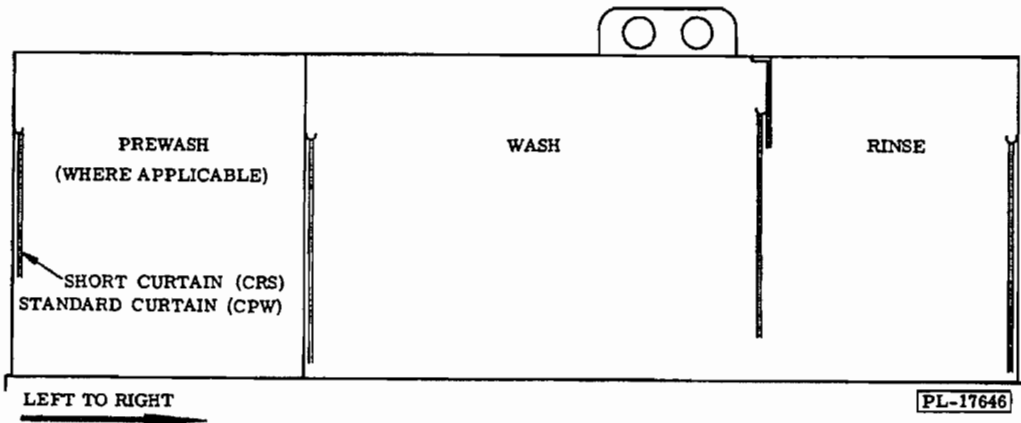

C-44 CRS-66 CPW-80
C-54 CRS-76 CPW-90

C-LINE INSTRUCTIONS

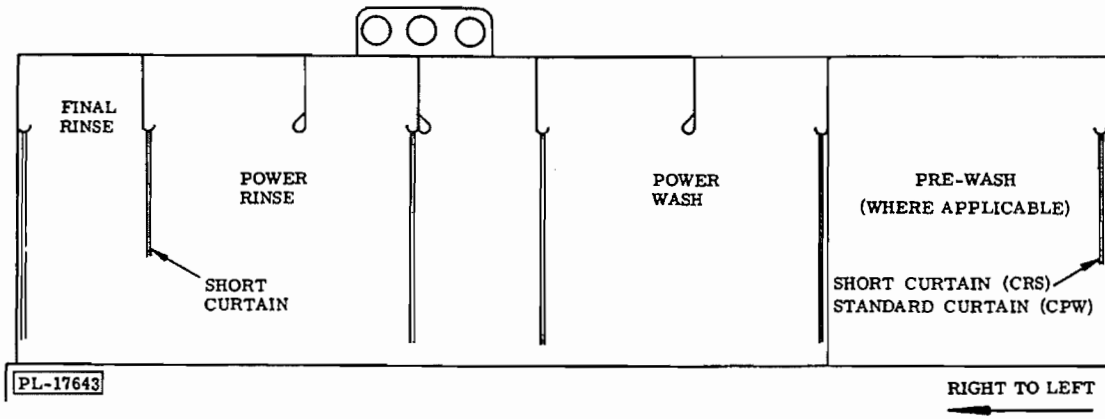

C-64	CRS-86	CPW-100
C-81	CRS-103	CPW-117

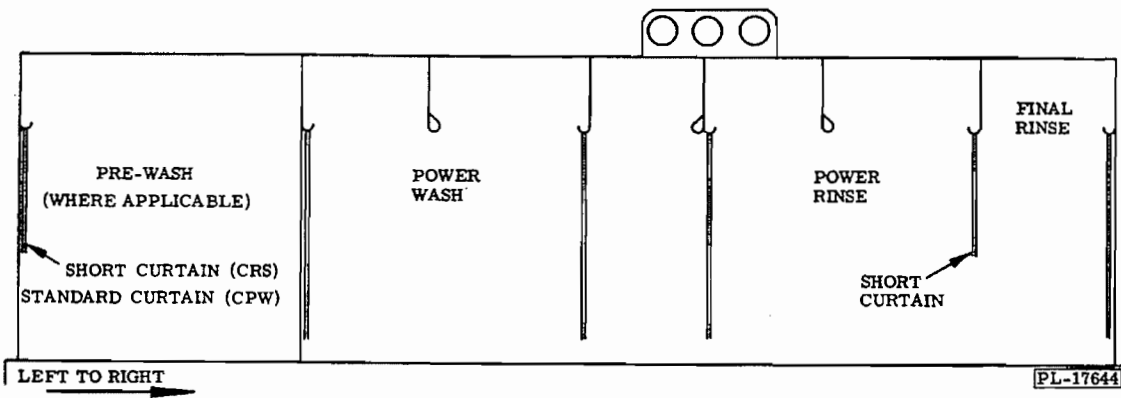

C-64	CRS-86	CPW-100
C-81	CRS-103	CPW-117