

# INSTALLATION

## *CLe*      **CONDENSER**

<i>CONDENSER-1</i>	<i>ML-138346-Z</i>
<i>CONDENSER-2</i>	<i>ML-138347-Z</i>
<i>CONDENSER-3</i>	<i>ML-138348-Z</i>
<i>CONDENSER-1T</i>	<i>ML-138349-Z</i>
<i>CONDENSER-2T</i>	<i>ML-138350-Z</i>
<i>CONDENSER-3T</i>	<i>ML-138351-Z</i>

<i>CNDSRHD-24</i>	<i>ML-138352-Z</i>
<i>CNDSRHD-32</i>	<i>ML-138353-Z</i>



701 S. RIDGE AVENUE  
TROY, OHIO 45374-0001

937 332-3000

[www.hobartcorp.com](http://www.hobartcorp.com)

FORM 34703 A (JAN 2016)

# Installation of CLE CONDENSER

## GENERAL

*The CLe Condenser removes excessive moisture from the exhaust air and conditions the air for its return to the dishroom, eliminating the need for watertight ducting. A rotating fan (driven by an electric motor) blows warm moist air over water-cooled coils. The moisture from the air condenses on the coils and drains away while the dehumidified cooled air exits through the condenser's louvers to the dishroom. The heated discharge water from the coils can be plumbed to the prewash tank or to a drain. The air discharge louvers can be re-positioned to alter the direction of air flowing out of the condenser. A cold water supply is used for the condenser coolant. The condenser includes a water economizer which controls the flow of water passing through the coils. A higher flow is provided at full operation. When no dishware is passing through the dishwasher, the final rinse is not employed, less warm moist air is venting and the water flow to the condenser is reduced. The required water supply pressure is a minimum of 20 psig, with a minimum flow rate of 6.0 gallons per minute. If the warm water from the condenser coil is plumbed to the prewash tank, refer to the dishwasher manual so that the water quality requirements are maintained.*

Note: Minimum 8 inches of clearance (between end of chamber and control box) is required on top of the dish machine to install a condenser using a 24 inch Condenser Hood. A 32 inch Condenser Hood is required when the minimum 8 inches of clearance is not available.

## INSTALLATION

*Immediately after unpacking the condenser and hood, check for possible shipping damage. If either is found to be damaged, save the packaging material and contact the carrier within 5 days of delivery.*

*Prior to installation, test the electrical service to make sure it agrees with the specifications on the machine data plate located on the condenser and the dishwasher.*

## ASSEMBLY

### Installing the Condenser Hood (Fig. 1)

Mount the Condenser Hood to the exit end of the dishwasher (Fig. 1). Apply the foam tape, supplied, to the end of the dishwasher where the condenser hood will be installed so there is a foam tape junction between the condenser hood and the end of the dishwasher. The foam tape will be across the top and down both sides. Attach the condenser hood to the dishwasher using the thirteen  $\frac{5}{16} - 18 \times \frac{5}{8}$ " long machine screws and stop nuts supplied (5 screws along the top and 4 screws down each side).

Right-to-Left Operation Exit End Shown  
Left-to-Right Operation Exit End Opposite

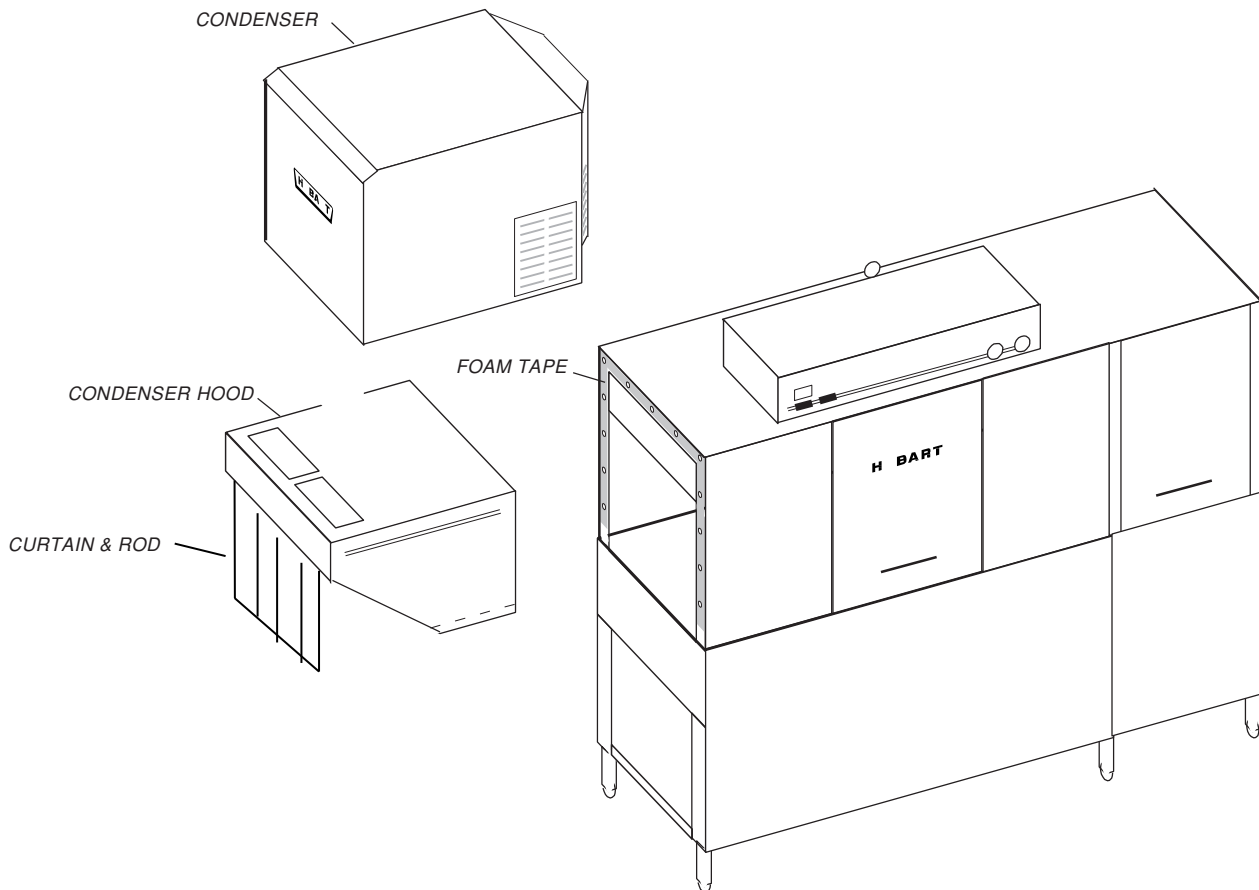

Fig. 1

Note: C-Line-A shown (Discontinued)

CLe not shown

## Installing the Condenser

Position the condenser base drip shield on top of the condenser hood and attach with eight 10 – 24 x 1/2" screws and elastic stop nuts, provided (Fig. 2). Position the condenser on the condenser base drip shield. Using the base drip shield and condenser as a template, drill eleven 1/4" diameter mounting holes through the top of the condenser hood and the dishwasher: Drill 4 of the 11 holes along the front side of the condenser, 4 holes along the rear side of the condenser and 3 holes in the top of the dishwasher at the louvered end of the condenser (Fig. 2).

Raise the condenser. Apply 1" wide foam tape on the mating surfaces underneath, where the condenser flanges will mount (Fig. 2).

Mount the condenser on top of the condenser hood; a slight portion of the condenser extends to the top of the dishwasher (Fig. 3). Attach the condenser and the condenser base drip shield to the condenser hood and dishwasher using the eleven 10 – 24 x 1/2" screws and stop nuts, provided: Install 4 of the 11 screws along the front side and 4 screws along the rear side — through the condenser and the condenser hood. Install the remaining 3 screws at the louvered end through the condenser, the base drip shield and the top of the dishwasher. Trim the foam tape if necessary.

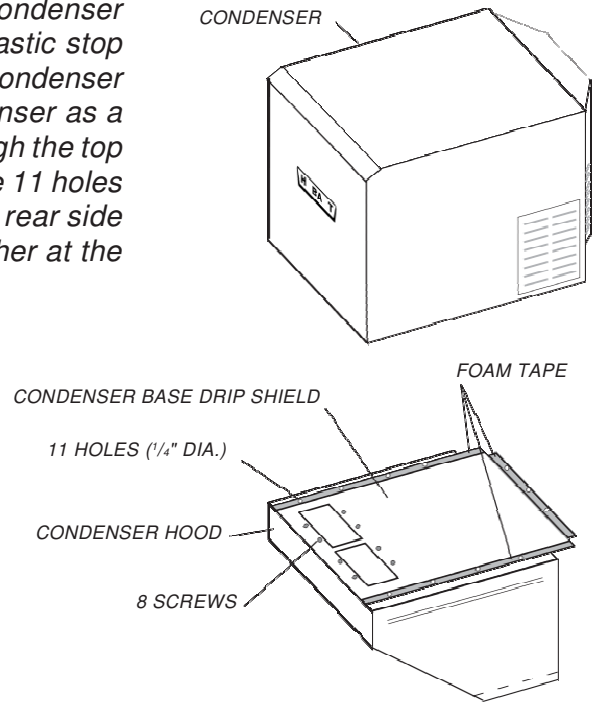

Fig. 2

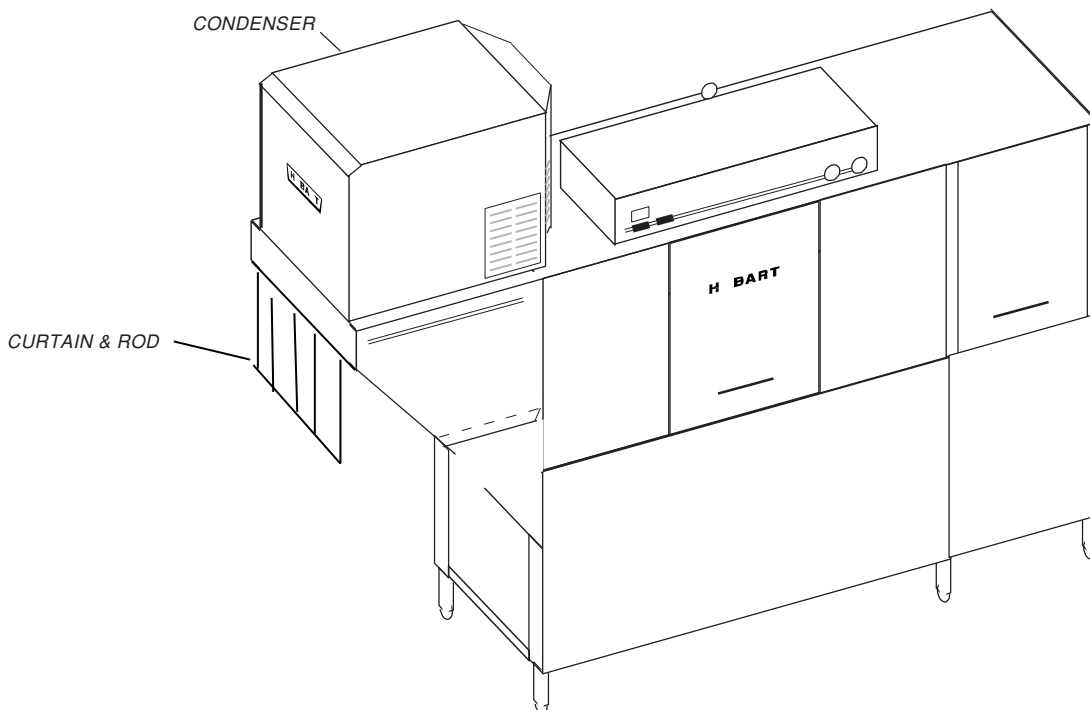

Fig. 3

Note: C-Line-A shown (Discontinued)

CLe not shown

## PLUMBING CONNECTIONS

**WARNING:** PLUMBING CONNECTIONS MUST COMPLY WITH APPLICABLE SANITARY, SAFETY, AND PLUMBING CODES.

*Pipe joint compound, not supplied, must be used on all threaded plumbing connections.*

*The plumber who connects this machine is responsible for making certain that incoming water lines are THOROUGHLY FLUSHED OUT before connecting to any manual valve or solenoid valve.*

*This "flush-out" is necessary to remove all foreign matter, such as chips (resulting from cutting or threading of pipes), pipe joint compound from the lines, or, if soldered fittings are used, bits of solder or cuttings from tubing. Debris, if not removed, may lodge in the valves and render them inoperative.*

*Manual valves or solenoid valves fouled by foreign matter, and any expenses resulting from this fouling, are NOT the responsibility of the manufacturer.*

## DRAIN CONNECTION

*The outflow of warm water from the condenser coil can be plumbed to the prewash section of the dishwasher or to customer's drain from the 1/2 inch external threaded pipe fitting on either the rear or front of the condenser. Typically, the rear outflow fitting is used; however, if access to the rear of the dishwasher is restricted, the plumbing line may be more easily installed in the front. In either case, the alternate drain fitting, opposite the fitting being used, should be capped with the 1/2 inch pipe cap, provided (Fig. 4).*

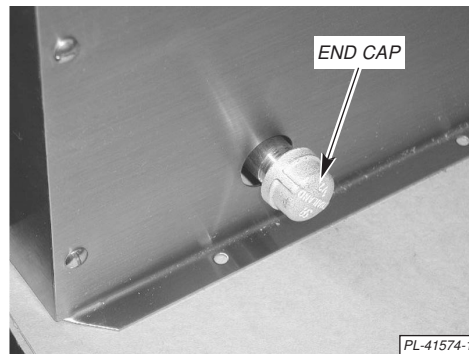

Fig. 4

## COLD WATER SUPPLY CONNECTION

*The cold water supply line to the condenser must be a minimum of 3/4 inch pipe. The inlet water supply connection is located at the midline (front to back) below the louvered end of the condenser. Route the incoming supply line behind the control box using the water supply piping and fittings supplied. Install the piping and fittings according to Fig. 5 for left-to-right operation at the exit end; install according to Fig. 6 for right-to-left operation at the exit end. For installations of the condenser at the load end, use Fig. 5 for right-to-left operation; use Fig. 6 for left-to-right.*

### Water Supply Piping and Fittings

Part No.	Qty.	Description
FP-40-42	3	Nipple $1/2"$ x $1 1/8"$
FP-77-63	1	Reducing Coupling $3/4"$ to $1/2"$
812982	1	Ball Valve $1/2"$
102515	1	Strainer
FP-15-16	1	Elbow $1/2"$ x $90^\circ$
FP-41-10	1	Pipe $1/2"$ x $9 3/4"$
FP-28-15	1	Pipe Plug $1/2"$

In either case, place the strainer at a 45° angle to allow removal of the clean-out plug to clean the strainer.

#### Left-to-Right Operation Exit End Shown

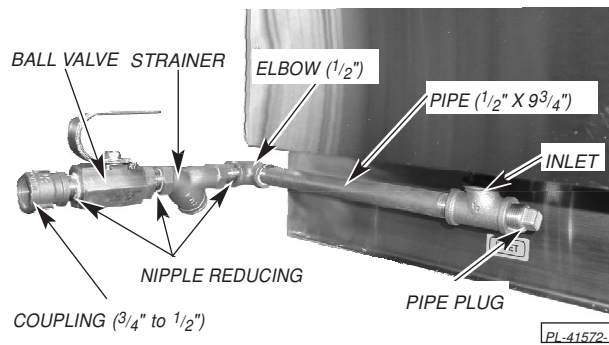

Fig. 5

#### Right-to-Left Operation Exit End Shown

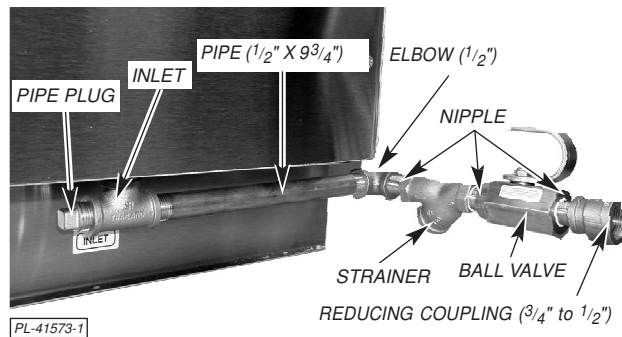

Fig. 6

## ELECTRICAL CONNECTIONS

**WARNING:** ELECTRICAL AND GROUNDING CONNECTIONS MUST COMPLY WITH APPLICABLE PORTIONS OF THE NATIONAL ELECTRICAL CODE AND/OR OTHER LOCAL ELECTRICAL CODES.

**WARNING:** DISCONNECT THE ELECTRICAL POWER SUPPLY AND PLACE A TAG AT THE DISCONNECT SWITCH INDICATING THAT YOU ARE WORKING ON THE CIRCUIT.

Refer to the electrical diagram inside the condenser control box.

Conduit is provided pre-wired from the condenser. A conduit fitting must be fastened to the hole provided in the dishwasher control box. Remove the conduit nut from the conduit. Feed the wires from the end of the conduit into the dishwasher control box. Tighten the conduit nut to the conduit fitting inside the control box. Connect L1 and L2 on a single-phase condenser (connect L1, L2 and L3 on a three-phase condenser) to the pump motor contactor labeled 3CON in the dishwasher control box. Connect the gray wire to terminal 6TB-N on terminal board. Connect the red wire to terminal 10TB-3 on terminal board. Connect the pink wire to terminal 10TB-5 on terminal board. When connecting the dishwasher electrical supply, allow sufficient amperage for the increase required by the addition of the condenser motor:

### ELECTRICAL DATA

Volts / Hertz / Phase	Motor Amps (Each Condenser)
200 – 240 / 60 / 1	3.5
200 – 240 / 60 / 3	2.2
400 – 480 / 60 / 3	1.1

*Electrician should allow an increase in the ampacity of the circuit supplying the dishwasher to allow for the additional requirements of the condenser blower motor(s).*

### CHECK MOTOR ROTATION (Three-Phase Machines)

The blower on any three-phase condenser must rotate in the direction of the arrow on the condenser housing. Before placing the machine into service, check to verify correct rotation by observing the condenser fan at the louvered end of the condenser.

If the blower does not rotate in the direction of the arrow on the condenser housing, DISCONNECT THE ELECTRICAL POWER SUPPLY(IES) and interchange any two of the blower motor's incoming power supply leads. Reconnect electrical power and verify that the blower rotates in the proper direction.

**SERVICE**

*If service is needed on this equipment, contact your local Hobart Service Office.*