



CATALOG OF REPLACEMENT PARTS

AM15 SERIES DISHWASHERS



ML-130038
ML-130039
ML-130045
ML-130153
ML-130154
ML-130155

AM15
AM15T
AM15F
AM15VL
AM15VLT
AM15VLF

Table of Contents

5	CONTROLS
7	CONTROL CABLES
9	CONTROL BOX (ELECTRIC HEAT)
11	CONTROL BOX (GAS HEAT) (ML-130038, ML-130039, & ML-130045)
13	MOTOR AND PUMP (BEFORE S/N 231131226)
15	MOTOR AND PUMP (STARTING S/N 231131226)
17	UPPER WASH ARM
19	LOWER WASH ARM
21	RINSE PIPING (WITHOUT BOOSTER AND WITHOUT STEAM CONDENSER)
23	RINSE PIPING (WITH BOOSTER AND WITHOUT STEAM CONDENSER)
25	OUTSIDE PIPING WITH STEAM CONDENSER
27	BOOSTER PIPING (AM15, AM15T, & AM15F)
29	RINSE PUMP ASSEMBLY (ML-130153, ML-130154, & ML-130155)
31	ELECTRIC BOOSTER TANK
33	STEAM CONDENSER
35	LOW WATER PROTECTION AND ELECTRIC HEAT
37	DRAIN UNIT
39	DRAIN WATER TEMPERING
41	DOOR ASSEMBLY (AM15 & AM15VL)
43	DOOR ASSEMBLY (AM15T, AM15F, AM15VLT, & AM15VLF)
45	PANELS AND RACK SUPPORT
47	GAS HEAT PIPING
49	GAS HEAT COMPONENTS
51	FRONT TRAY
53	DISH RACKS
55	DOOR LOCK (AM15VL)
57	DOOR LOCK - ELECTRICAL (AM15VL)

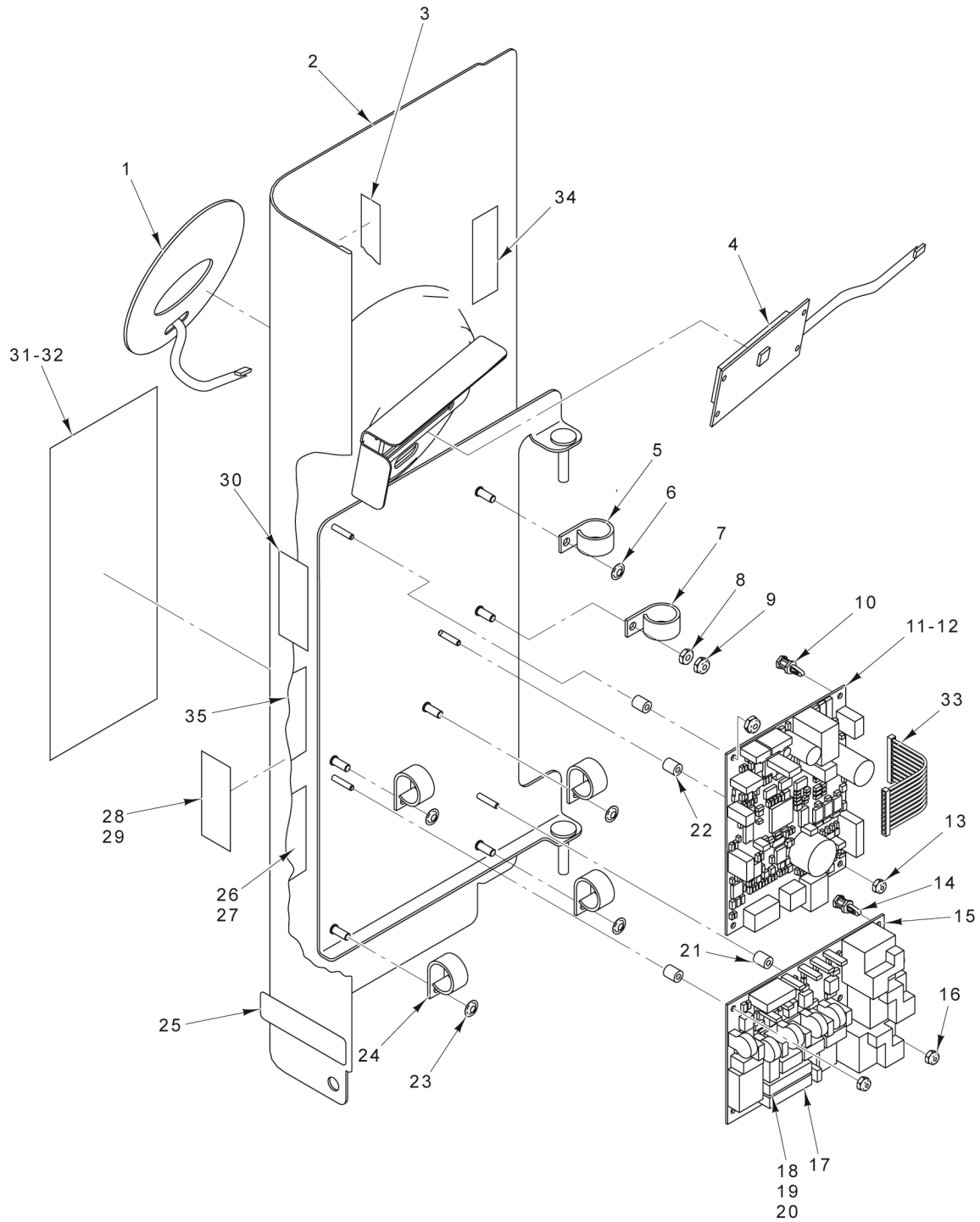

PL-57404

CONTROLS

CONTROLS

ILLUS. PL-57404	PART NO.	NAME OF PART	AMT.
1	00-893113	Switch - Membrane Keypad.....	1
2	00-893040	Bezel - Display Weldment.....	1
3	00-526454	Tape - Foam.....	AR
4	00-892458	Module - Display.....	1
5	00-294677-00003	Clamp - Wire (3/4 I.D.).....	1
6	NS-047-94	Lock Nut 3/16 Washer Type (SST).....	1
7	00-294677-00003	Clamp - Wire (3/4 I.D.).....	1
8	NS-011-18	Nut 10-24 Hex (SST).....	1
9	NS-031-16	Stop Nut 10-24 Hex Elastic (SST).....	1
10	00-892720-00002	Standoff.....	2
11	00-892932	Control Board Assy.....	1
12	00-974590	Control Board Assy. (AM15SVL Only).....	1
13	NS-031-50	Stop Nut 6-32 Hex (SST).....	2
14	00-892720-00002	Standoff.....	2
15	00-892934-00002	Board - Relay Assy.....	1
16	NS-031-50	Stop Nut 6-32 Hex (SST).....	2
17	FE-022-29	Fuse (250 V., 1.0 Amp.).....	1
18	FE-026-30	Fuse (250 V., 0.1 Amp.) (AM15, AM15T, & AM15F).....	1
19	FE-019-11	Fuse (250 V., 0.3 Amp.) (AM15VL, AM15VLT, & AM15VLF).....	1
20	FE-021-19	Fuse (3.2 Amp., 250 V.) F2 (Gas Only).....	1
21	00-118349-00007	Standoff - Reed Board (Relay Board).....	2
22	00-118349-00007	Standoff - Reed Board (Control Board).....	2
23	NS-047-94	Lock Nut 3/16 Washer Type (SST).....	4
24	00-294677-00003	Clamp - Wire (3/4 I.D.).....	4
25	00-893642	Plate (Patent Numbers).....	1
26	0F-035324	Label - Warning (Fuse) (Electric Heat).....	1
27	0F-035373	Label - Warning (Fuse) (Gas Heat).....	1
28	00-438131-00060	Label - Warning (With Electric Booster).....	1
29	00-438131-00042	Label - Warning (With Gas Heat, With Electric Booster S.P.E.C. or Without Electric Booster).....	1
30	0F-035331	Label (Error Code).....	1
31	00-438131-00175	Label - Instruction.....	1
32	00-941234	Label - Instruction (Ventless) (AM15VL, AM15VLT, & AM15VLF).....	1
33	00-892793-00002	Ribbon Cable Assy.....	1
34	0F-035331a	Label - Error Label AM15.....	1
35	0F-038359	Label - Warning (Fuse) AM15.....	1

Item Number	Description
1	Ribbon Cable Assy.
2	Harness - Sensor Assy. (AM15, AM15T, & AM15F)
3	Harness - Relay Board Assy. (AM15, AM15T, & AM15F)
4	Cable - Rinse Thermistor (AM15, AM15T, & AM15F)
5	Cable - Rinse Valve (W/O Electric Booster) (Incls. DIN Connector) (AM15, AM15T, & AM15F) (Before S/N 231154994)
6	Cable - Rinse Valve (W/Electric Booster) (Incls. DIN Connector) (AM15, AM15T, & AM15F) (Before S/N 231154994)
7	Cable Assy. - Rinse Thermistor (AM15VL, AM15VLT, & AM15VLF)
8	Cable Assy. - Fan/Cold Water Valve (AM15VL, AM15VLT, & AM15VLF)
9	Cable Assy. - Hot Water Valve (AM15VL, AM15VLT, & AM15VLF) (Before S/N 231154994)
10	Cable Assy. - Cold Water Valve (AM15VL, AM15VLT, & AM15VLF) (Before S/N 231154994)
11	Cable Assy. - Cold Water Valve (AM15VL, AM15VLT, & AM15VLF) (Starting S/N 235114994)
12	Cable Assy. - Light (AM15VL, AM15VLT, & AM15VLF).
13	Harness - High Voltage (AM15VL, AM15VLT, & AM15VLF)
14	Harness - Low Voltage (Sensors & Door Switch) (AM15VL, AM15VLT, & AM15VLF)
15	Cable - Rinse Valve (W/O Electric Booster) (Incls. DIN Connector) (AM15, AM15T, & AM15F) (Starting S/N 231154994)
16	Cable - Rinse Valve (W/Electric Booster) (Incls. DIN Connector) (AM15, AM15T, & AM15F) (Starting S/N 231154994)
17	Cable Assy. - Hot Water Valve (Incls. DIN Connector) (AM15VL, AM15VLT, & AM15VLF) (Starting S/N 231154994)

PL-60462

CONTROL CABLES

CONTROL CABLES

ILLUS. PL-60462	PART NO.	NAME OF PART	AMT.
1	00-892793-00002	Ribbon Cable Assy.....	1
2	00-893447	Harness - Sensor Assy. (AM15, AM15T, & AM15F).....	1
3	00-893448	Harness - Relay Board Assy. (AM15, AM15T, & AM15F).....	1
4	00-893125	Cable - Rinse Thermistor / Door Switch (AM15, AM15T, & AM15F).....	1
5	00-893126-00001	Cable - Rinse Valve (W/O Electric Booster) (Incls. DIN Connector) (AM15, AM15T, & AM15F) (Before S/N 231154994).....	1
6	00-893126-00002	Cable - Rinse Valve (W/Electric Booster) (Incls. DIN Connector) (AM15, AM15T, & AM15F) (Before S/N 231154994).....	1
7	00-941222	Cable Assy. - Rinse Thermistor (AM15VL, AM15VLT, & AM15VLF).....	1
8	00-941170	Cable Assy. - Fan/Cold Water Valve (AM15VL, AM15VLT, & AM15VLF).....	1
9	00-893126-00003	Cable Assy. - Hot Water Valve (AM15VL, AM15VLT, & AM15VLF) (Before S/N 231154994).....	1
10	00-941173	(Before S/N 231154994).....	1
11	00-949340	Cable Assy. - Cold Water Valve (AM15VL, AM15VLT, AM15VLF) (Starting S/N 231154994).....	1
12	00-941174	Cable Assy. - Light (AM15VL, AM15VLT, & AM15VLF).....	1
13	00-941185	Harness - High Voltage (AM15VL, AM15VLT, & AM15VLF).....	1
14	00-941186	Harness - Low Voltage (Sensors & Door Switch) (AM15VL, AM15VLT, & AM15VLF).....	1
15	00-949337-00001	Cable - Rinse Valve (W/O Electric Booster) (Incls. DIN Connector) (AM15, AM15T, & AM15F) (Starting S/N 231154994).....	1
16	00-949337-00002	Cable - Rinse Valve (W/Electric Booster) (Incls. DIN Connector) (AM15, AM15T, & AM15F) (Starting S/N 231154994).....	1
17	00-949337-00003	Cable Assy. - Hot Water Valve (Incls. DIN Connector) (AM15VL, AM15VLT, & AM15VLF) (Starting S/N 231154994).....	AR

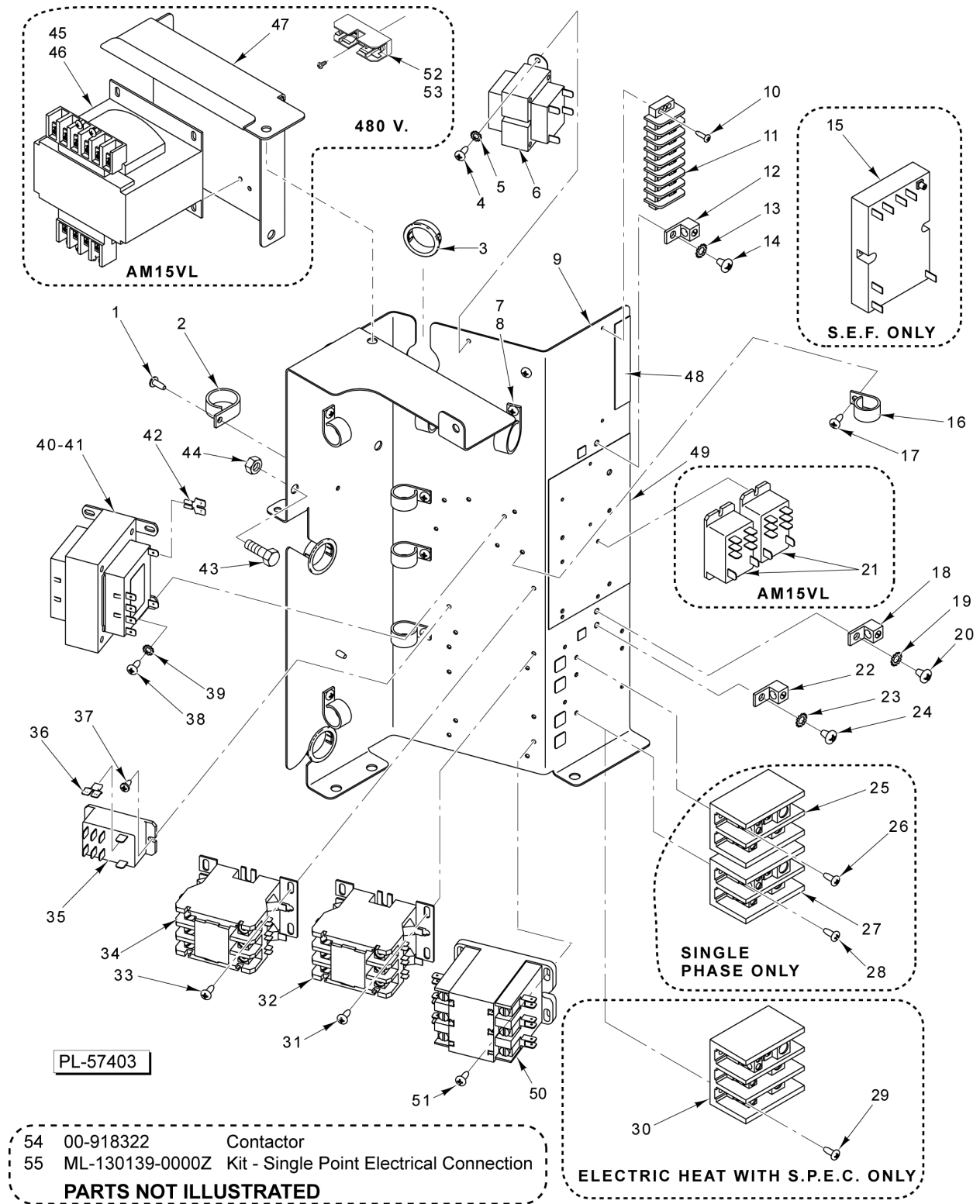

**CONTROL BOX
(ELECTRIC HEAT)**

CONTROL BOX (ELECTRIC HEAT)

ILLUS. PL-57403	PART NO.	NAME OF PART	AMT.
1	SD-008-25	Self-Tapping Screw 10-16 x 1/2 Phil. Pan Hd., Type B.....	3
2	00-294677-00004	Clamp - Wire (1 I.D.).....	3
3	FE-026-29	Bushing - Electrical Snap.....	3
4	SD-008-25	Self-Tapping Screw 10-16 x 1/2 Phil. Pan Hd., Type B.....	2
5	WL-014-07	Lockwasher #10 External Shakeproof (SST).....	2
6	00-294500-00051	Transformer (T2) (30 V. 50/60 Hz.).....	1
7	SD-008-25	Self-Tapping Screw 10-16 x 1/2 Phil. Pan Hd., Type B.....	2
8	00-294677-00004	Clamp - Wire (1 I.D.).....	2
9	00-893651	Box - Control.....	1
10	SD-019-29	Self-Tapping Screw 6-20 x 1/2 Phil. Pan Hd., Type B.....	2
11	00-893065	Block - Terminal (Double Row).....	1
12	00-118544-00002	Lug - Grounding.....	1
13	WL-007-15	Lockwasher 1/4 External Shakeproof.....	1
14	SD-035-77	Self-Tapping Screw 1/4-20 x 3/8 Phil. Pan Hd., Type TT.....	1
15	00-814247	Microcontroller - Final Rinse Alarm (S.E.F. Only).....	1
16	00-294677-00003	Clamp - Wire (3/4 I.D.).....	6
17	SD-008-25	Self-Tapping Screw 10-16 x 1/2 Phil. Pan Hd., Type B.....	6
18	00-118544-00002	Lug - Grounding (Electric Booster).....	1
19	WL-007-15	Lockwasher 1/4 External Shakeproof (Electric Booster).....	1
20	SD-035-77	Self-Tapping Screw 1/4-20 x 3/8 Phil. Pan Hd., Type TT (Electric Booster).....	1
21	00-087714-046-1	Relay (2-Pole) (30 Amp.) (AM15VL).....	2
22	00-118544-00002	Lug - Grounding.....	1
23	WL-007-15	Lockwasher 1/4 External Shakeproof.....	1
24	SD-035-77	Self-Tapping Screw 1/4-20 x 3/8 Phil. Pan Hd., Type TT.....	1
25	00-294325-00022	Block - Terminal (1 Ph.).....	1
26	SD-008-25	Self-Tapping Screw 10-16 x 1/2 Phil. Pan Hd., Type B (1 Ph.).....	2
27	00-294325-00022	Block - Terminal (Electric Booster) (1 Ph.).....	1
28	SD-008-25	Self-Tapping Screw 10-16 x 1/2 Phil. Pan Hd., Type B (Electric Booster) (1 Ph.).....	2
29	SD-008-25	Self-Tapping Screw 10-16 x 1/2 Phil. Pan Hd., Type B (Electric Heat W/S.P.E.C.)	4
30	00-119031	Block - Terminal (Electric Heat With S.P.E.C.).....	1
31	SD-008-25	Self-Tapping Screw 10-16 x 1/2 Phil. Pan Hd., Type B.....	2
32	00-087713-108-1	Contactor (25 Amp., 3-Pole).....	1
33	SD-008-25	Self-Tapping Screw 10-16 x 1/2 Phil. Pan Hd., Type B.....	2
34	00-087713-108-1	Contactor (25 Amp., 3-Pole).....	1
35	00-087714-046-1	Relay (2-Pole) (30 Amp.).....	1
36	FE-026-26	Adapter - Electrical.....	1
37	SD-008-18	Self-Tapping Screw 8-18 x 3/8 Phil. Bndg. Hd., Type B.....	2
38	SD-008-25	Self-Tapping Screw 10-16 x 1/2 Phil. Pan Hd., Type B.....	4
39	WL-014-07	Lockwasher #10 External Shakeproof (SST).....	4
40	00-294500-052-1	Transformer (T1) (208/240/480 V., 50/60 Hz.).....	1
40A	00-294500-046-1	Transformer (T1) (Used With AM15VL Door Lock Assembly).....	1
41	00-294500-052-2	Transformer (T1) (380/415 V., 50/60 Hz.).....	1
42	FE-026-26	Adapter - Electrical.....	1
43	SC-041-14	Cap Screw 5/16-18 x 1-1/8 Hex Hd. (SST).....	4
44	NS-036-19	Stop Nut 5/16-18 Hex (SST).....	4
45	00-294500-00053	Transformer (480 V.) (AM15VL).....	1
46	FE-023-25	Fuse (250 V., 5 Amp.).....	1
47	00-941201	Bracket - High Voltage Transformer.....	1
48	0F-035319	Label - Terminal Block.....	1
49	0F-044182	Label - Electric Ampacity.....	1
50	00-918322	Contactor (40 Amp., 3-Pole) (120 V.) (Electric Booster With S.P.E.C.).....	1
51	SD-008-25	Self-Tapping Screw 10-16 x 1/2 Phil. Pan Hd., Type B.....	2
52	00-294436-00003	Block - Fuse Block - Fuse (480 V. Units).....	1
53	FE-023-25	Fuse (5.0 Amp., 250 V.).....	1
54	00-918322	Contactor (40 Amp., 3-Pole).....	1
55	ML-130139-0000Z	Kit - Single Point Electrical Connection.....	1

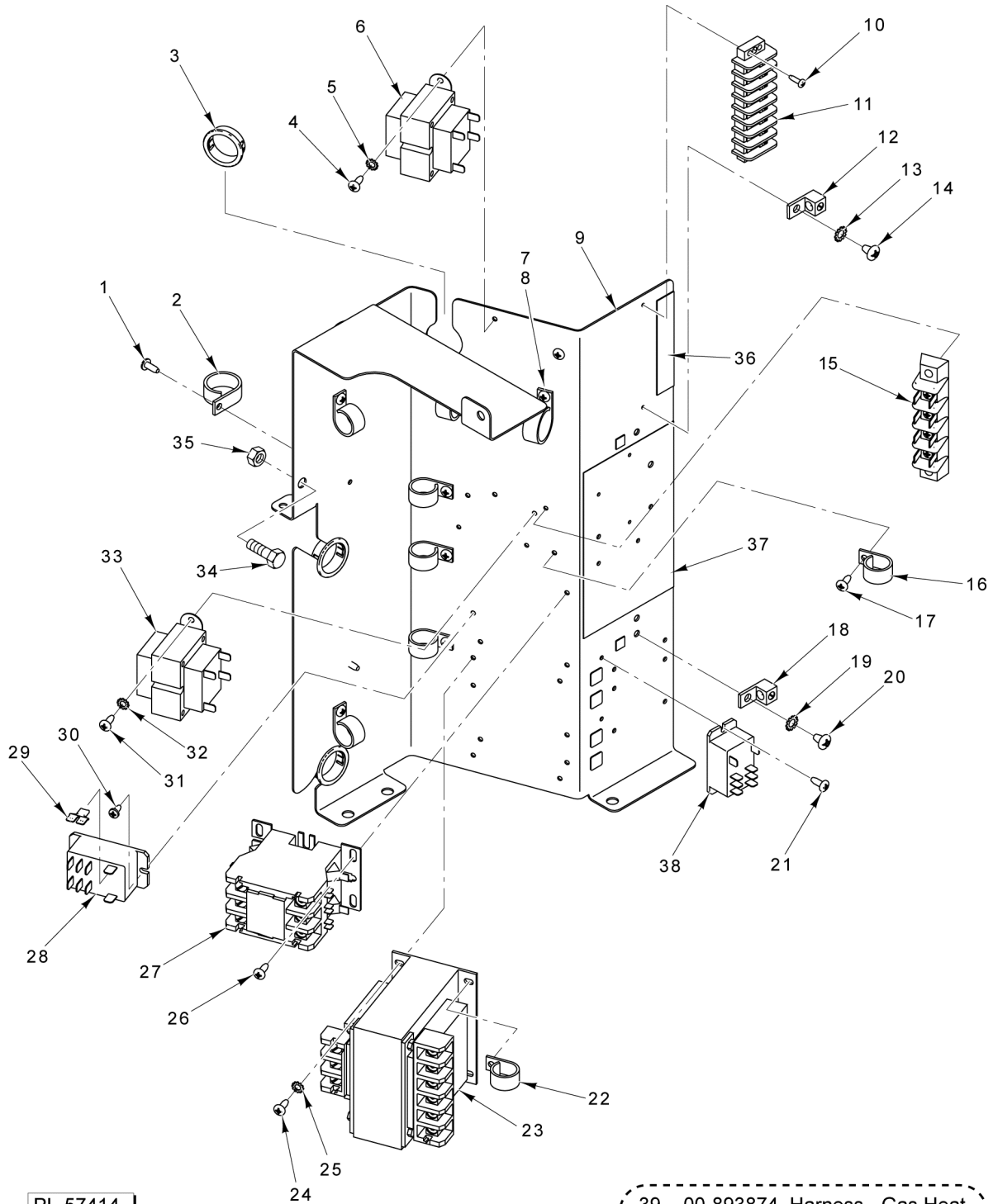

PL-57414

39 00-893874 Harness - Gas Heat
PART NOT ILLUSTRATED

**CONTROL BOX
(GAS HEAT)
(ML-130038, ML-130039, & ML-130045)**

**CONTROL BOX
(GAS HEAT)
(ML-130038, ML-130039, & ML-130045)**

ILLUS. PL-57414	PART NO.	NAME OF PART	AMT.
1	SD-008-25	Self-Tapping Screw 10-16 x 1/2 Phil. Pan Hd., Type B.....	3
2	00-294677-00004	Clamp - Wire (1 I.D.).....	3
3	FE-026-29	Bushing - Electrical Snap.....	3
4	SD-008-25	Self-Tapping Screw 10-16 x 1/2 Phil. Pan Hd., Type B.....	2
5	WL-014-07	Lockwasher #10 External Shakeproof (SST).....	2
6	00-294500-00051	Transformer (T2) (30 V. 50/60 Hz.).....	1
7	SD-008-25	Self-Tapping Screw 10-16 x 1/2 Phil. Pan Hd., Type B.....	2
8	00-294677-00004	Clamp - Wire (1 I.D.).....	2
9	00-893651	Box - Control.....	1
10	SD-019-29	Self-Tapping Screw 6-20 x 1/2 Phil. Pan Hd., Type B.....	2
11	00-893065	Block - Terminal (Double Row).....	1
12	00-118544-00002	Lug - Grounding.....	1
13	WL-007-15	Lockwasher 1/4 External Shakeproof.....	1
14	SD-035-77	Self-Tapping Screw 1/4-20 x 3/8 Phil. Pan Hd., Type TT.....	1
15	00-294325-00023	Block - Terminal (Single Row).....	1
16	00-294677-00003	Clamp - Wire (3/4 I.D.).....	6
17	SD-008-25	Self-Tapping Screw 10-16 x 1/2 Phil. Pan Hd., Type B.....	6
18	00-118544-00002	Lug - Grounding.....	1
19	WL-007-15	Lockwasher 1/4 External Shakeproof.....	1
20	SD-035-77	Self-Tapping Screw 1/4-20 x 3/8 Phil. Pan Hd., Type TT.....	1
21	SD-008-18	Self-Tapping Screw 8-18 x 3/8 Phil. Bndg. Hd., Type B.....	2
22	00-294677-00003	Clamp - Wire (3/4 I.D.).....	2
23	00-294500-046-2	Transformer (T1) (300 VA, 50/60 Hz.).....	1
24	SD-008-25	Self-Tapping Screw 10-16 x 1/2 Phil. Pan Hd., Type B.....	4
25	WL-014-07	Lockwasher #10 External Shakeproof (SST).....	4
26	SD-008-25	Self-Tapping Screw 10-16 x 1/2 Phil. Pan Hd., Type B.....	2
27	00-087713-108-1	Contact (25 Amp., 3-Pole).....	1
28	00-087714-046-1	Relay (2-Pole) (30 Amp.).....	1
29	FE-026-26	Adapter - Electrical.....	1
30	SD-008-18	Self-Tapping Screw 8-18 x 3/8 Phil. Bndg. Hd., Type B.....	2
31	SD-008-25	Self-Tapping Screw 10-16 x 1/2 Phil. Pan Hd., Type B.....	2
32	WL-014-07	Lockwasher #10 External Shakeproof (SST).....	2
33	00-294500-040-1	Transformer (30 VA, 50/60 Hz.).....	1
34	SC-041-14	Cap Screw 5/16-18 x 1-1/8 Hex Hd. (SST).....	4
35	NS-036-19	Stop Nut 5/16-18 Hex (SST).....	4
36	0F-035319	Label - Terminal Block.....	1
37	0F-044182	Label - Electric Ampacity.....	1
38	00-087714-046-1	Relay (2-Pole) (30 Amp.).....	1
39	00-893874	Harness - Gas Heat.....	1

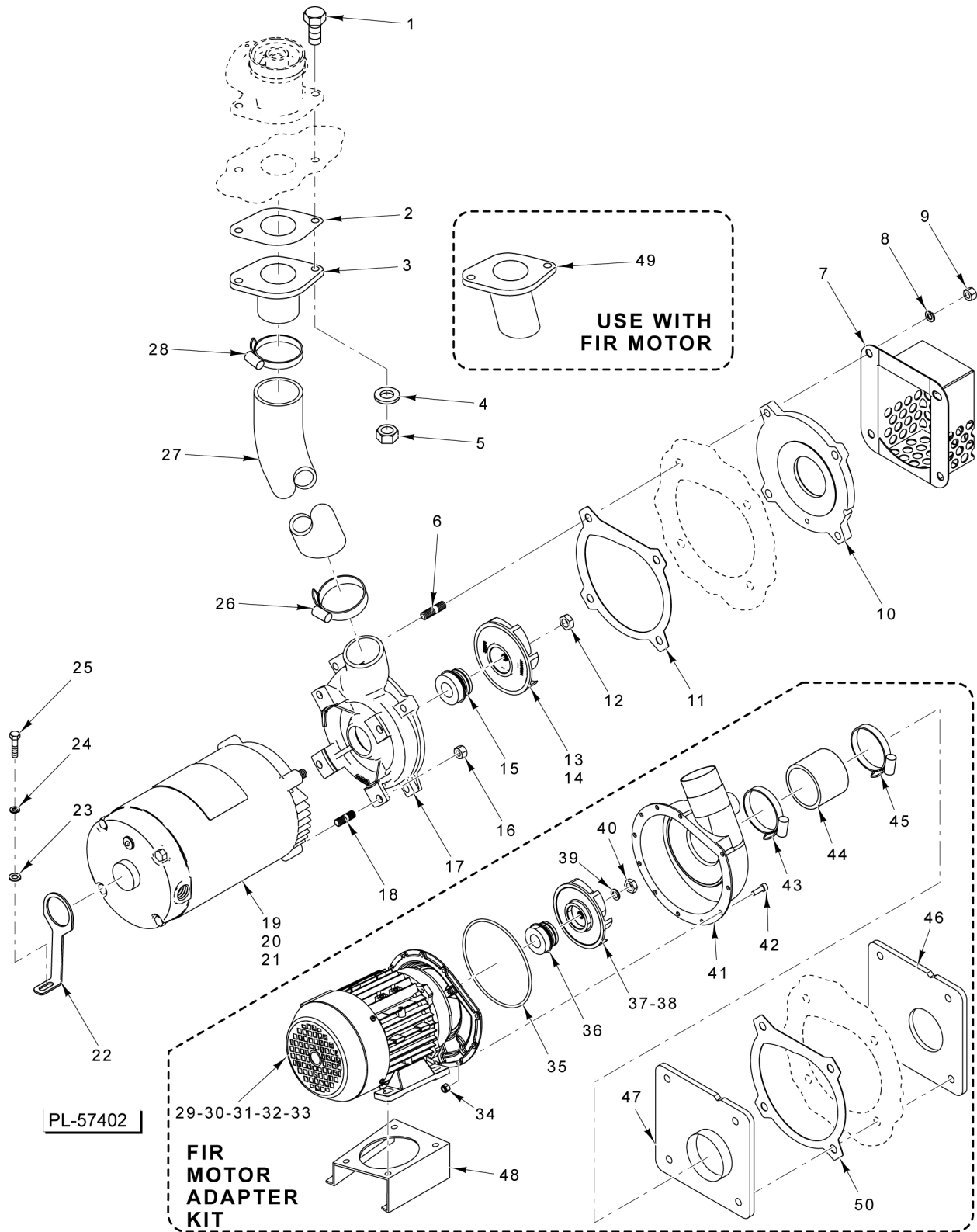

**MOTOR AND PUMP
(BEFORE S/N 231131226)**

**MOTOR AND PUMP
(BEFORE S/N 231131226)**

ILLUS.	PART NO.	NAME OF PART	AMT.
PL-57402			
1	SC-041-14	Cap Screw 5/16-18 x 1-1/8 Hex Hd. (SST).....	2
2	00-893103	Gasket - Adapter.....	1
3	00-893102-00001	Adapter - Pump-to-Manifold.....	1
4	WS-017-01	Washer 0.328 x 0.875 x 0.062 (SST).....	2
5	NS-036-19	Stop Nut 5/16-18 Hex (SST).....	2
6	00-893039-00006	Stud 3/8-16 x 1-5/8.....	4
7	00-893063	Screen - Pump.....	1
8	WL-006-28	Lockwasher 3/8 Helical.....	4
9	00-893039-00012	Nut 3/8-16 Hex (SST).....	4
10	00-893039-00005	Face - Pump Inside.....	1
11	00-893039-00004	Gasket - Pump-to-Tank.....	1
12	00-893039-00003	Jam Nut 7/16-20 Hex.....	1
13	00-893039-00002	Impeller (60 Hz.).....	1
14	00-893039-00011	Impeller (50 Hz.).....	1
15	00-274227-00006	Seal - Shaft.....	1
16	00-893039-00012	Nut 3/8-16 Hex (SST).....	4
17	00-893039-00001	Involute.....	1
18	00-893039-00007	Stud 3/8-16 x 1-1/8.....	4
19	00-893039-00008	Motor (208-240/480 V., 60 Hz., 3 Ph.).....	1
20	00-893039-00009	Motor (208-240 V., 60 Hz., 1 Ph.).....	1
21	00-893039-00010	Motor (240-380 V., 50 Hz., 3 Ph.).....	1
22	00-893035	Brace - Pump.....	1
23	WS-017-01	Washer 0.328 x 0.875 x 0.062 (SST).....	1
24	WL-006-23	Lockwasher 5/16 Helical (SST).....	1
25	SC-041-11	Cap Screw 5/16-18 x 3/4 Hex Hd. (SST).....	1
26	00-542337	Clamp - Hose.....	1
27	00-893024	Hose - Discharge.....	1
28	00-542337	Clamp - Hose.....	1
29	00-941233-00001	Motor (208-240/480/60/3).....	1
30	00-941233-00002	Motor (208-240/60/1).....	1
31	00-941233-00015	Fan - Cooling 60 Hz.....	1
32	00-936863-00001	Pump & Motor Assembly 208-240/480/60/3.....	1
33	00-936863-00002	Pump & Motor Assembly 208-240/60/1.....	1
34	00-941233-00013	Lock Nut 6mm (SST).....	11
35	00-941233-00010	Seal.....	1
36	00-941233-00005	Shaft - Seal.....	1
37	00-941233-00006	Impeller (60 Hz.).....	1
38	00-941233-00007	Impeller (50 Hz.).....	1
39	00-941233-00008	Lockwasher 10mm (SST).....	1
40	00-941233-00009	Jam Nut 10mm (SST).....	1
41	00-941233-00011	Pump Shell (Outer).....	1
42	00-941233-00012	Mach. Screw 6mm x 18mm (SST).....	11
43	00-521462	Clamp - Hose.....	1
44	00-941241	Hose - Pump Intake.....	1
45	00-521462	Clamp - Hose.....	1
46	00-941102	Flange - Pump.....	1
47	00-941104	Bracket - Inlet.....	1
48	00-936772	Bracket - Motor Mounting.....	1
49	00-941106	Adapter (Pump-to-Manifold) (Use With FIR Motor).....	1
50	00-893039-00004	Gasket - Pump-to-Tank.....	1

**MOTOR AND PUMP
(STARTING S/N 231131226)**

ILLUS. PL-60690	PART NO.	NAME OF PART	AMT.
1	SC-041-14	Cap Screw 5/16-18 x 1-1/8 Hex Hd. (SST).....	2
2	00-893103	Gasket - Adapter.....	1
3	00-941106	Adapter (Pump-to-Manifold).....	1
4	WS-017-01	Washer 0.328 x 0.875 x 0.062 (SST).....	2
5	NS-036-19	Stop Nut 5/16-18 Hex (SST).....	2
6	00-893063	Screen - Pump.....	1
7	WL-006-23	Lockwasher 5/16 Helical (SST).....	4
8	NS-015-11	Nut 5/16-18 Hex (SST).....	4
9	00-521462	Clamp - Hose.....	2
10	00-941241	Hose - Pump Intake.....	1
11	00-941233-00012	Mach. Screw 6mm x 18mm (SST).....	11
12	00-941233-00011	Pump Shell (Outer).....	1
13	00-941233-00006	Impeller (60 Hz.).....	1
14	00-941233-00005	Shaft - Seal.....	1
15	00-941233-00010	Seal.....	1
16	00-941233-00013	Lock Nut 6mm (SST).....	11
17	00-936772	Bracket - Motor Mounting.....	1
18	00-941233-00001	Motor (208-240/480/60/3) (208-240/480/60/3).....	1
19	00-941233-00002	Motor (208-240/60/1) (208-240/60/1).....	1
20	00-941233-00015	Fan - Cooling 60 Hz.....	1
21	00-936863-00001	Pump & Motor Assembly 208-240/480/60/3.....	1
22	00-936863-00002	Pump & Motor Assembly 208-240/60/1.....	1
23	00-542337	Clamp - Hose.....	2
24	00-893024	Hose - Discharge.....	1
25	00-941233-00008	Lockwasher 10mm (SST).....	1
26	00-941233-00009	Jam Nut 10mm (SST).....	1

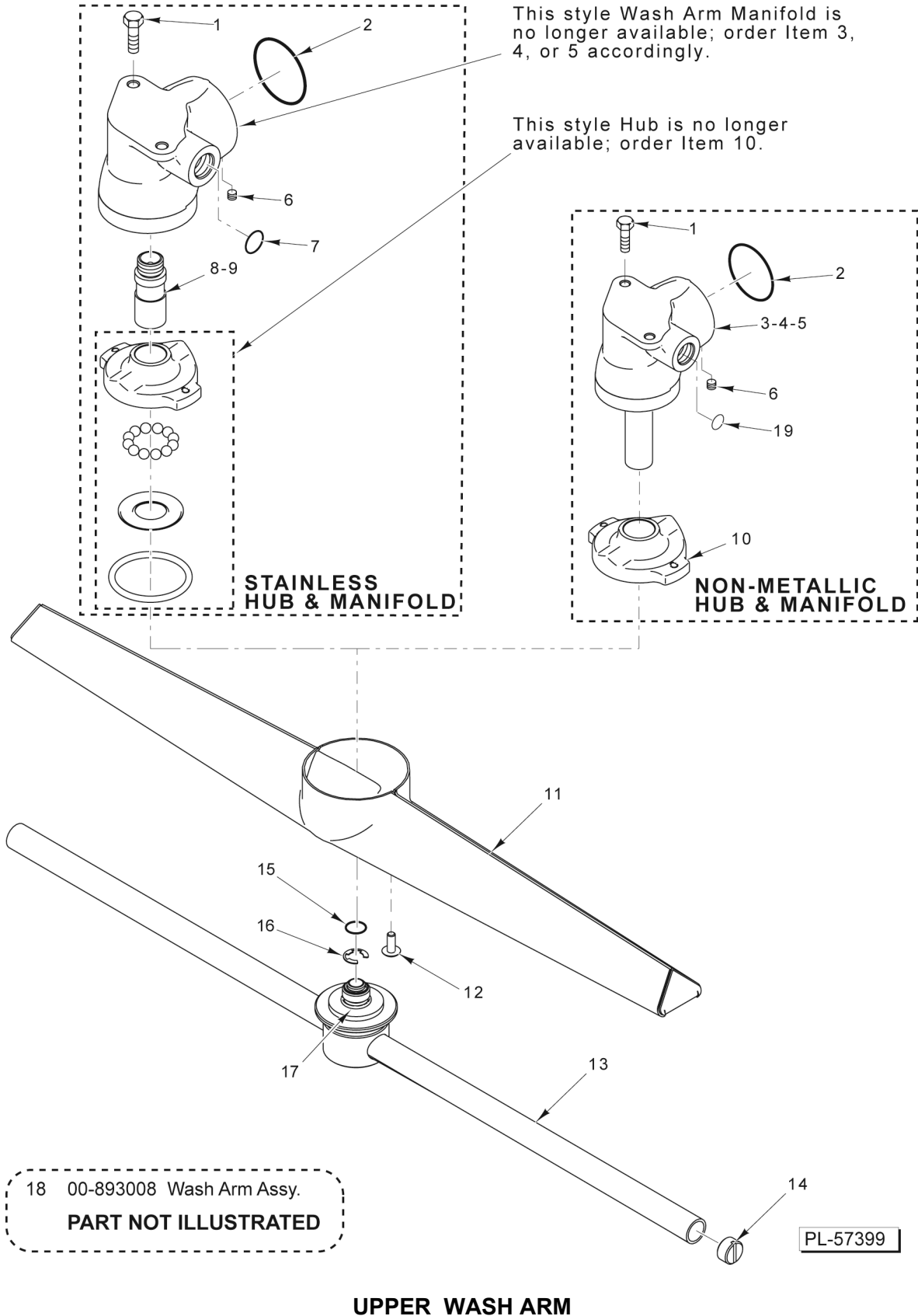

UPPER WASH ARM

ILLUS.	PART NO.	NAME OF PART	AMT.
1	SC-125-20	Cap Screw 5/16-18 x 3/8 Hex Hd.....	2
2	00-067500-00110	O-Ring.....	1
3	00-974072-00001	Kit - Wash Manifold Assy. (Incls. Shaft and Item 10).....	1
4	00-974072-00002	Kit - Wash Manifold Assy. (AM15VL, AM15VLT, AM15VLF) (Incls. Shaft and Item 10)	1
5	00-974072-00003	Kit - Wash Manifold Assy. (AM15VL) (50 Hz.) (Incls. Shaft and Item 10).....	1
6	SC-055-01	Set Screw 10-24 x 1/4 Hex Hdls., Cup Pt. (SST).....	1
7	00-067500-00117	O-Ring (Stainless Manifold Only).....	1
8	00-893052	Shaft - Rinse Arm (AM15, AM15T, AM15F) (Stainless Manifold Only).....	1
9	00-893052-00002	Shaft - Rinse Arm (AM15VL, AM15VLT, AM15VLF) (Stainless Manifold Only).....	1
10	00-948668	Hub - Wash Arm.....	1
11	00-893007	Arm - Wash.....	1
12	SC-066-06	Mach. Screw 10-24 x 1/2 Phil. Truss Hd. (SST).....	2
13	00-893093-00001	Arm - Rinse (Incls. Items 14 & 17).....	1
14	00-893093-00002	Plug - Rinse Arm.....	2
15	00-067500-00147	O-Ring.....	1
16	RR-011-98	Retaining Ring.....	1
17	00-893074	Bearing.....	1
18	00-893008	Wash Arm Assy. (Incls Items 10 thru 12).....	1
19	00-067500-00153	O-Ring.....	1

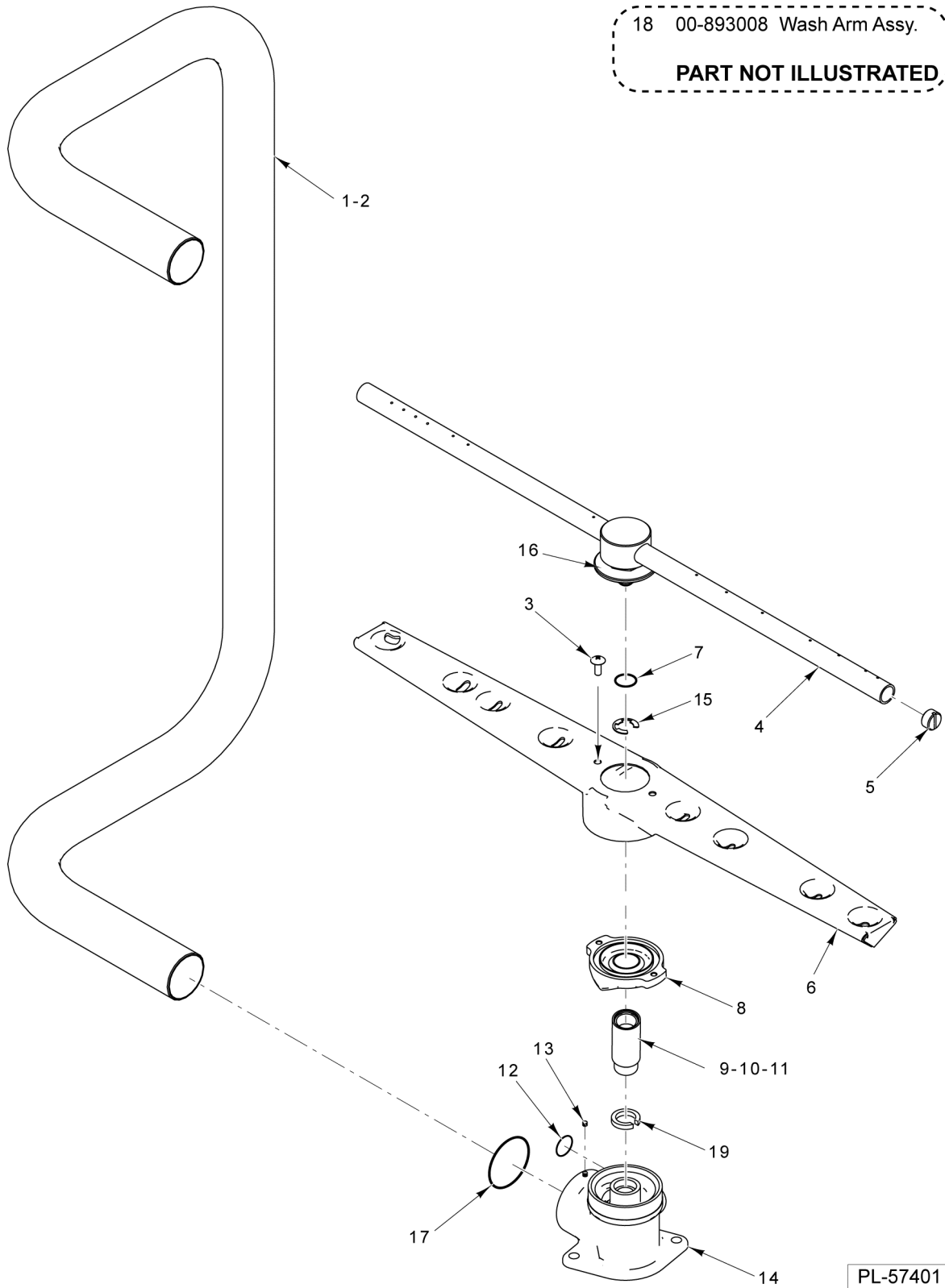

LOWER WASH ARM

PL-57401

LOWER WASH ARM

ILLUS.	PART NO.	NAME OF PART	AMT.
PL-57401			
1	00-893032	Tube - Wash (AM15).....	1
2	00-893032-00002	Tube - Wash (AM15T & AM15F).....	1
3	SC-066-06	Mach. Screw 10-24 x 1/2 Phil. Truss Hd. (SST).....	2
4	00-893093-00001	Arm - Rinse (Incls. Items 5 & 16).....	1
5	00-893093-00002	Plug - Rinse Arm.....	2
6	00-893007	Arm - Wash.....	1
7	00-067500-00147	O-Ring.....	1
8	00-948668	Hub - Wash Arm.....	1
9	00-893052	Shaft - Rinse Arm.....	1
10	00-893052-00002	Shaft - Rinse Arm (AM15) (Ventless).....	1
11	00-893052-00003	Shaft - Rinse Arm (AM15VL) (Ventless) (50 Hz.).....	1
12	00-067500-00153	O-Ring.....	1
13	SC-055-01	Set Screw 10-24 x 1/4 Hex Hdls., Cup Pt. (SST).....	2
14	00-893030	Manifold - Wash (Lower).....	1
15	RR-011-98	Retaining Ring.....	1
16	00-893074	Bearing.....	1
17	00-067500-00110	O-Ring.....	1
18	00-893008	Wash Arm Assy. (Incls. Items 3, 6, & 8).....	1
*19	00-893044	Bushing - Wash Arm.....	AR

* Only use with metal Wash Arm Hub, Item 8.

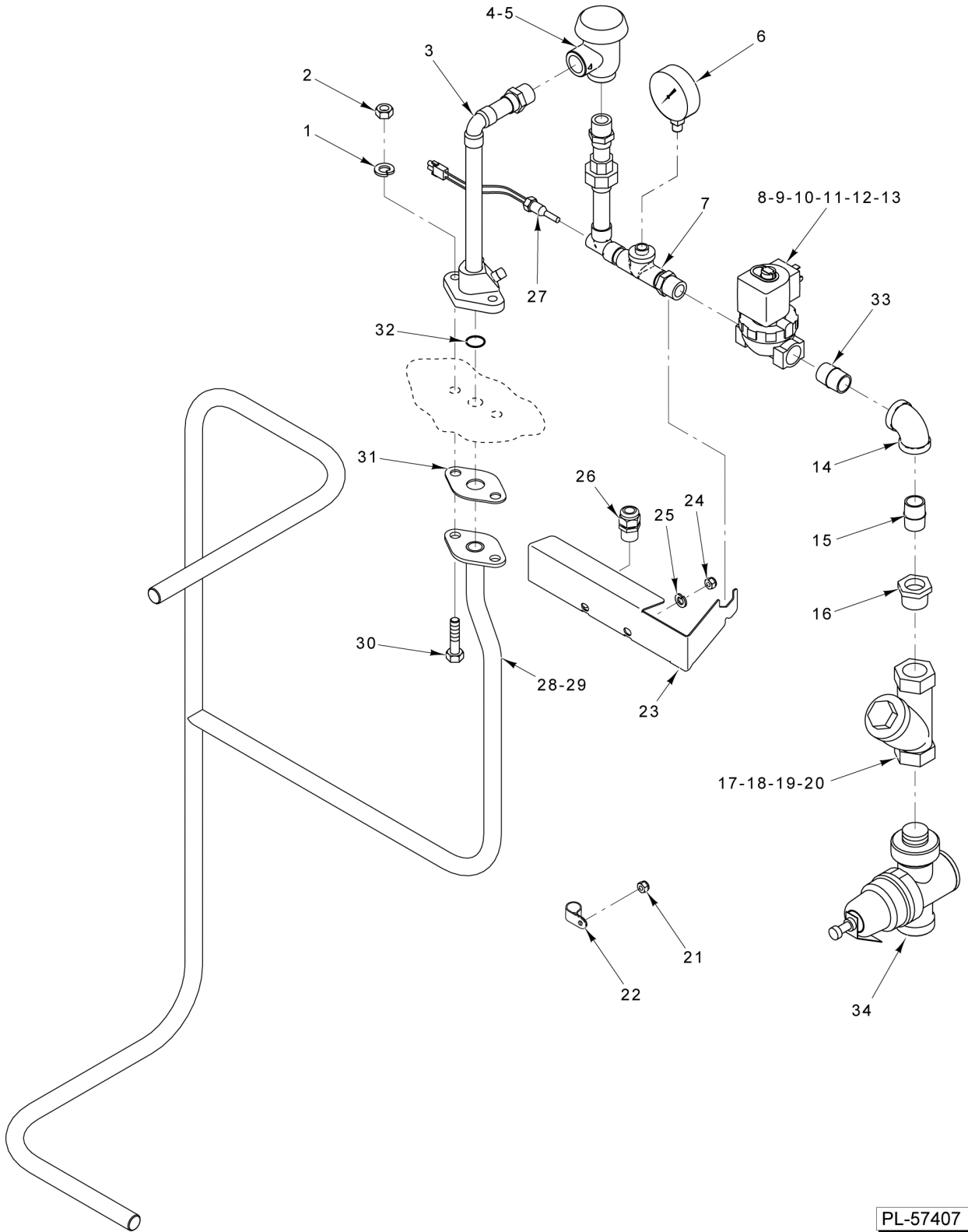

PL-57407

**RINSE PIPING
(WITHOUT BOOSTER AND WITHOUT STEAM CONDENSER)**

**RINSE PIPING
(WITHOUT BOOSTER AND WITHOUT STEAM CONDENSER)**

ILLUS. PL-57407	PART NO.	NAME OF PART	AMT.
1	WL-006-23	Lockwasher 5/16 Helical (SST).....	2
2	NS-036-19	Stop Nut 5/16-18 Hex (SST).....	2
3	00-893054	Piping - Fill.....	1
4	00-292909	Breaker - Vacuum.....	1
5	00-292910	Service Kit - Vacuum Breaker.....	1
6	00-918429	Gauge - Water Pressure.....	1
7	00-893058	Fill Piping Assy.....	1
8	00-893100-00001	Solenoid Valve (1/2) (120 V.) (Before Serial No. 231154994).....	1
9	00-936121	Valve - Solenoid (1/2) (120 V.) (Starting Serial No. 231154994).....	1
10	00-892132	Coil - Solenoid Valve (120 V.) (Before Serial No. 231154994).....	1
11	00-936283	Coil - Solenoid Valve (120 V.) (Starting Serial No. 231154994).....	1
12	00-893101	Service Kit - 1/2 Solenoid Valve (Before Serial No. 231154994).....	1
13	00-476615	Connector - D.I.N. (Parker style valve only).....	1
14	FP-015-17	Elbow - Pipe 1/2 x 90 Deg. (Brass).....	1
15	FP-054-36	Pipe 1/2 x 2 TBE (Brass).....	1
16	FP-027-22	Bushing - Pipe 3/4 to 1/2 (Brass).....	1
17	00-186922	Strainer - Line (3/4 In.) (Brass) (Incls. Items 18, 19, & 20).....	1
18	00-186923	Plug - Branch.....	1
19	00-186925	Screen - Line Strainer.....	1
20	00-186924	Gasket - Branch Plug.....	1
21	NS-047-94	Lock Nut 3/16 Washer Type (SST).....	1
22	00-294677-00004	Clamp - Wire (1 I.D.).....	1
23	00-893053	Bracket - Fill Piping.....	1
24	NS-015-11	Nut 5/16-18 Hex (SST).....	2
25	WL-006-23	Lockwasher 5/16 Helical (SST).....	2
26	FE-022-84	Connector - Strain Relief.....	2
27	00-328994	Probe Assy. - Rinse.....	1
28	00-893038-00001	Inside Rinse Piping Assy. (AM15).....	1
29	00-893038-00004	Inside Rinse Piping Assy. (AM15T & AM15F).....	1
30	SC-041-12	Cap Screw 5/16-18 x 7/8 Hex Hd. (SST).....	2
31	00-276407	Gasket - Rinse Pipe.....	1
32	00-067500-00012	O-Ring.....	1
33	FP-040-44	Pipe 1/2 x 1-3/8 TBE (Brass).....	1
34	00-118038-00003	Regulator - Pressure (1/2) (Brass).....	1

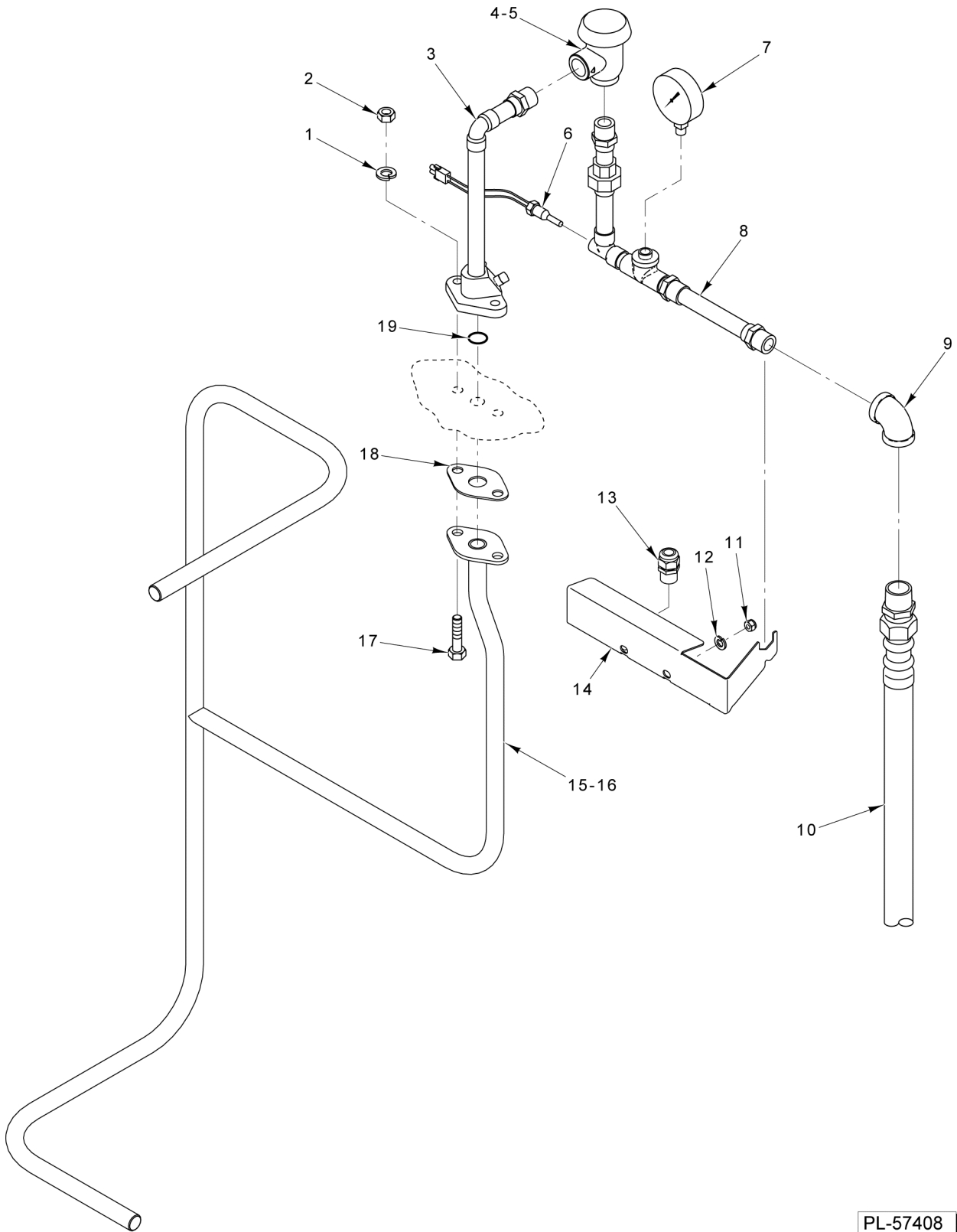

PL-57408

**RINSE PIPING
(WITH BOOSTER AND WITHOUT STEAM CONDENSER)**

**RINSE PIPING
(WITH BOOSTER AND WITHOUT STEAM CONDENSER)**

ILLUS. PL-57408	PART NO.	NAME OF PART	AMT.
1	WL-006-23	Lockwasher 5/16 Helical (SST).....	2
2	NS-036-19	Stop Nut 5/16-18 Hex (SST).....	2
3	00-893054	Piping - Fill.....	1
4	00-292909	Breaker - Vacuum.....	1
5	00-292910	Service Kit - Vacuum Breaker.....	1
6	00-328994	Probe Assy. - Rinse.....	1
7	00-918429	Gauge - Water Pressure.....	1
8	00-893059	Fill Piping Assy.....	1
9	FP-015-16	Elbow - Pipe 1/2 x 90 Deg. (Brass).....	1
10	00-893444-00002	Hose - Water 1/2 x 84 In. Braided (SST).....	1
11	NS-015-11	Nut 5/16-18 Hex (SST).....	2
12	WL-006-23	Lockwasher 5/16 Helical (SST).....	2
13	FE-022-84	Connector - Strain Relief.....	1
14	00-893053	Bracket - Fill Piping.....	1
15	00-893038-00001	Inside Rinse Piping Assy. (AM15).....	1
16	00-893038-00004	Inside Rinse Piping Assy. (AM15T & AM15F).....	1
17	SC-041-12	Cap Screw 5/16-18 x 7/8 Hex Hd. (SST).....	2
18	00-276407	Gasket - Rinse Pipe.....	1
19	00-067500-00012	O-Ring.....	1

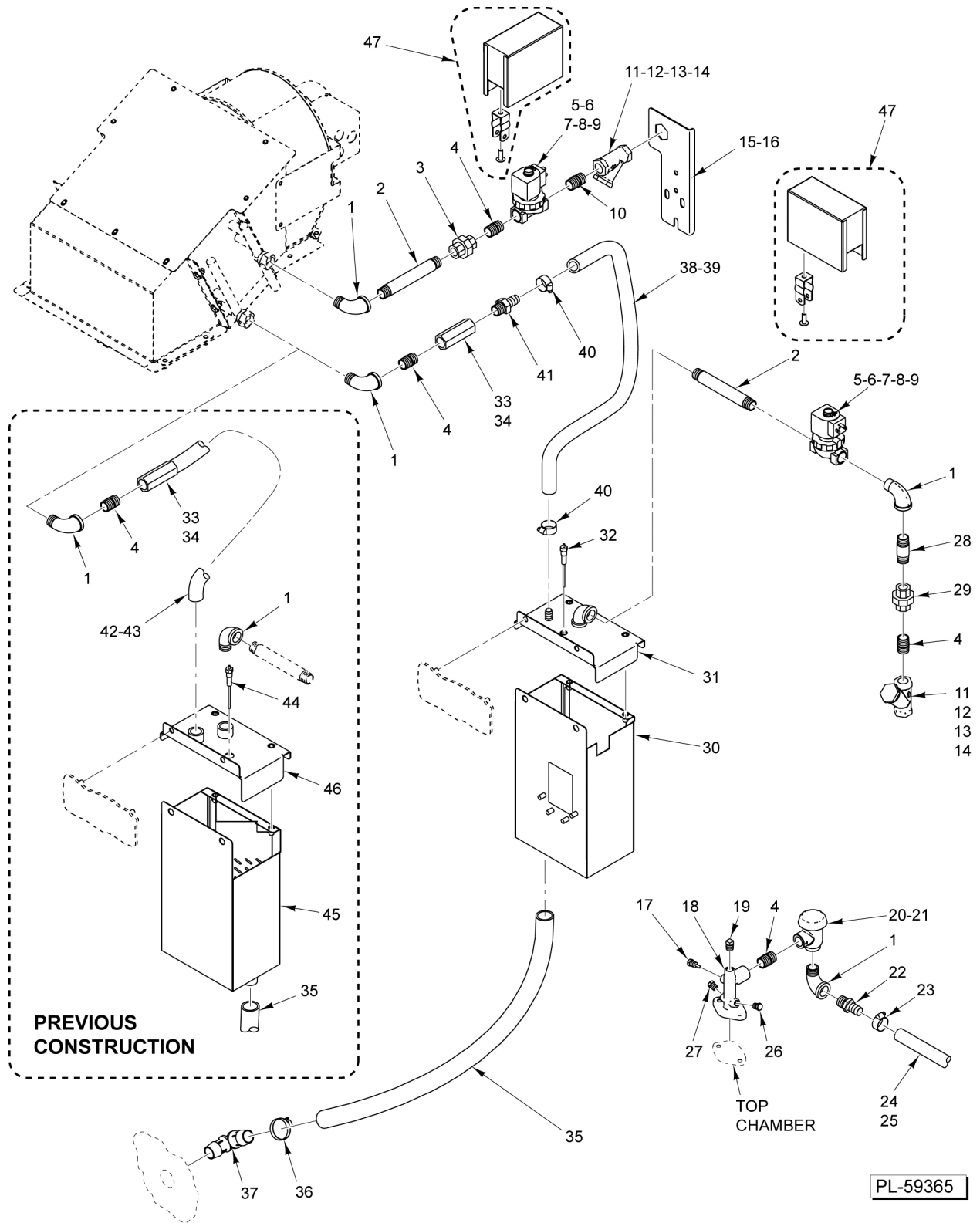

OUTSIDE PIPING WITH STEAM CONDENSER

OUTSIDE PIPING WITH STEAM CONDENSER

ILLUS. PL-59365	PART NO.	NAME OF PART	AMT.
1	FP-015-17	Elbow - Pipe 1/2 x 90 Deg. (Brass).....	5
2	FP-040-86	Pipe 1/2 x 5-1/2 TBE (Brass).....	2
3	FP-022-12	Union - Pipe (Brass).....	1
11	00-892921	Strainer - Line (Incls. Items 12, 13, & 14).....	2
4	FP-040-42	Pipe 1/2 x 1-1/8 TBE (Brass).....	4
5	00-893100-00001	Solenoid Valve (1/2) (120 V.) (Before Serial No. 231154994).....	2
6	00-936121	Valve - Solenoid (1/2) (120 V.) (Starting Serial No. 231154994).....	2
7	00-893101	Service Kit - 1/2 Solenoid Valve (Before Serial No. 231154994).....	AR
8	00-892132	Coil - Solenoid Valve (120 V.) (Before Serial No. 231154994).....	2
9	00-936283	Coil - Solenoid Valve (120 V.) (Starting Serial No. 231154994).....	2
10	FP-040-43	Pipe 1/2 x 1-1/4 TBE (Brass).....	1
11	00-892921	Strainer - Line.....	1
12	00-892922-00001	Cap.....	2
13	00-892922-00002	Gasket.....	2
14	00-892922-00003	Screen.....	2
15	00-941164	Bracket - Condenser.....	1
16	00-941136	Bracket - Ventless Electric.....	1
17	00-328994	Probe Assy. - Rinse.....	1
18	00-919560	Manifold - Top Rinse.....	1
19	FP-028-07	Pipe Plug 1/4 Sq. Hd. (Brass).....	1
20	00-292909	Breaker - Vacuum.....	1
21	00-292910	Service Kit - Vacuum Breaker.....	1
22	FP-087-39	Fitting - Hose 5/8 x 1/2 (Brass).....	2
23	00-528499	Clamp - Hose (SST).....	2
24	00-892244-00009	Hose - Adapta Flex (67 In.) (AM15VL).....	1
25	00-892244-00010	Hose - Adapta Flex (AM15VLT & AM15VLF).....	1
26	00-749123	Plug - Pipe.....	1
27	00-749123	Plug - Pipe.....	1
28	00-941215	Restrictor (1/2 In.).....	1
29	FP-022-12	Union - Pipe (Brass).....	1
30	00-941583	Tank Weldment.....	1
31	00-941685	Lid - Tank (Heat Recovery).....	1
32	00-329275-00003	Probe - Sump & Wire Assy.....	1
33	00-941239	Restrictor - Flow (1/2 In.).....	1
34	00-941196	Control - Flow.....	1
35	00-936468-00002	Hose - Ventless Intake.....	1
36	00-557627	Clamp - Hose.....	1
37	00-941127	Elbow - Hose (1 In.).....	1
38	00-941726-00006	Hose 3/8 (12 In. Lg.).....	1
39	00-941726-00005	Hose 3/8 (25 In. Lg.).....	1
40	00-558090	Clamp.....	2
41	FP-090-64	Adapter 1/2 MPT to 3/8 Hose.....	1
42	00-893444-00009	Hose - Water (Braided) (36 In.) (SST).....	1
43	00-918390-00007	Hose - Braided Water 1/2 x 48 In. (SST) (AM15VLT & AM15VLF).....	1
44	00-329275-00002	Probe - Sump & Wire Assy. (Before S/N 231145455).....	1
45	00-941100	Tank - Heat Recovery.....	AR
46	00-936997-00001	Tank - Heat Recovery Lid.....	1
47	00-974129	Kit - Solenoid Cover (AM15VL & AM15VLT) (Starting Serial No. 231171014).....	2

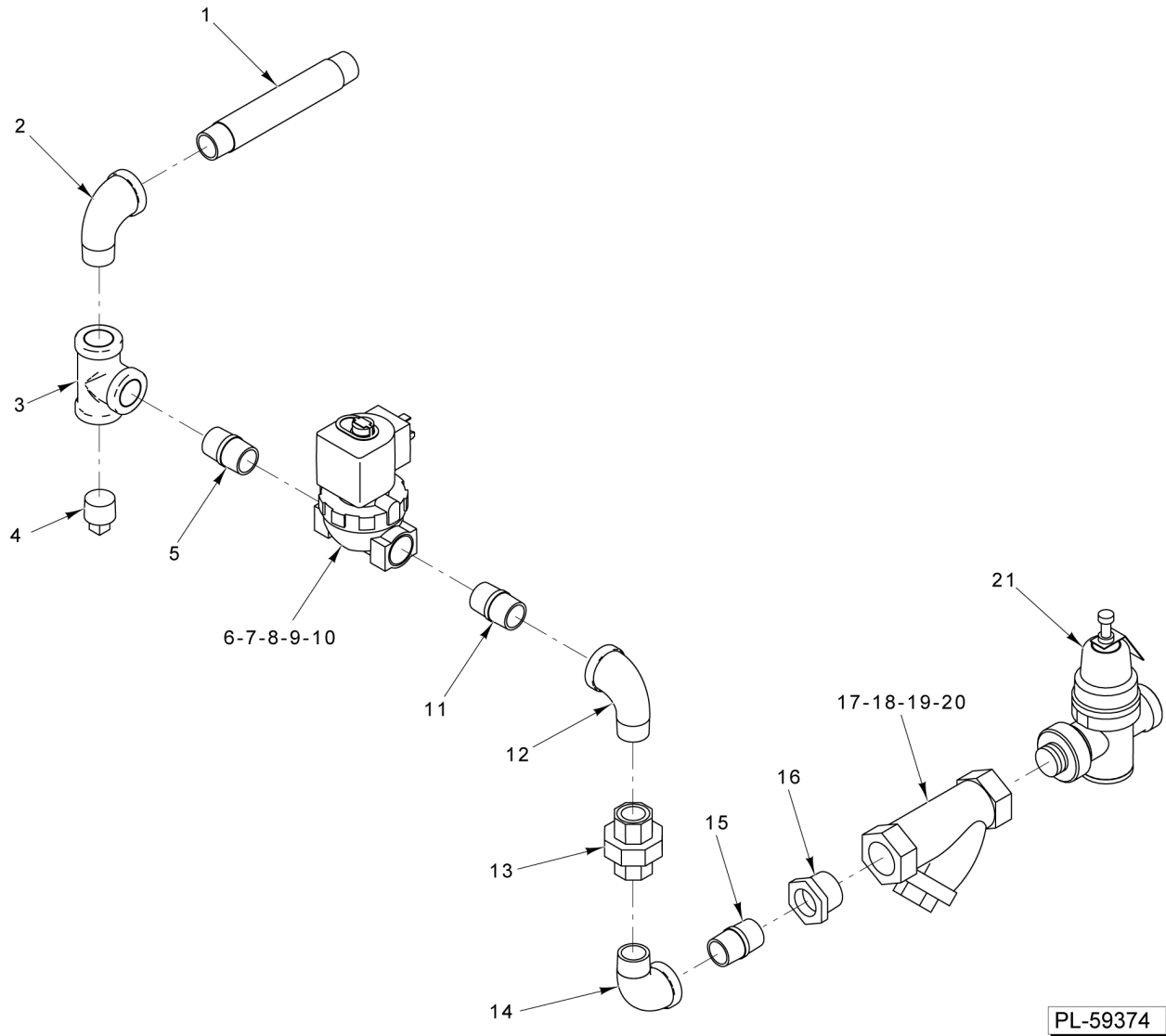

**BOOSTER PIPING
(AM15, AM15T, & AM15F)**

**BOOSTER PIPING
(AM15, AM15T, & AM15F)**

ILLUS. PL-59374	PART NO.	NAME OF PART	AMT.
1	FP-040-95	Pipe 1/2 x 7 TBE (Brass).....	1
2	FP-015-17	Elbow - Pipe 1/2 x 90 Deg. (Brass).....	1
3	FP-019-21	Tee - Pipe 1/2 x 1/2 x 1/2 (Brass).....	1
4	FP-028-15	Pipe Plug 1/2 Sq. Hd. (Brass).....	1
5	FP-040-43	Pipe 1/2 x 1-1/4 TBE (Brass).....	1
6	00-893100-00001	Solenoid Valve (1/2) (120 V.) (Before Serial No. 231154994).....	1
7	00-936121	Valve - Solenoid (1/2) (120 V.) (Starting Serial No. 231154994).....	1
8	00-893101	Service Kit - 1/2 Solenoid Valve (Before Serial No. 231154994).....	AR
9	00-892132	Coil - Solenoid Valve (120 V.) (Before Serial No. 231154994).....	1
10	00-936283	Coil - Solenoid Valve (120 V.) (Starting Serial No. 231154994).....	1
11	FP-040-43	Pipe 1/2 x 1-1/4 TBE (Brass).....	1
12	FP-015-17	Elbow - Pipe 1/2 x 90 Deg. (Brass).....	1
13	FP-022-12	Union - Pipe (Brass).....	1
14	FP-015-17	Elbow - Pipe 1/2 x 90 Deg. (Brass).....	1
15	FP-040-43	Pipe 1/2 x 1-1/4 TBE (Brass).....	1
16	FP-027-22	Bushing - Pipe 3/4 to 1/2 (Brass).....	1
17	00-186922	Strainer - Line (3/4 In.) (Brass) (Incls. Items 18, 19, & 20).....	1
18	00-186923	Plug - Branch.....	1
19	00-186925	Screen - Line Strainer.....	1
20	00-186924	Gasket - Branch Plug.....	1
21	00-118038-00003	Regulator - Pressure (1/2) (Brass).....	1

19 00-749123 Plug - Pipe
PART NOT ILLUSTRATED

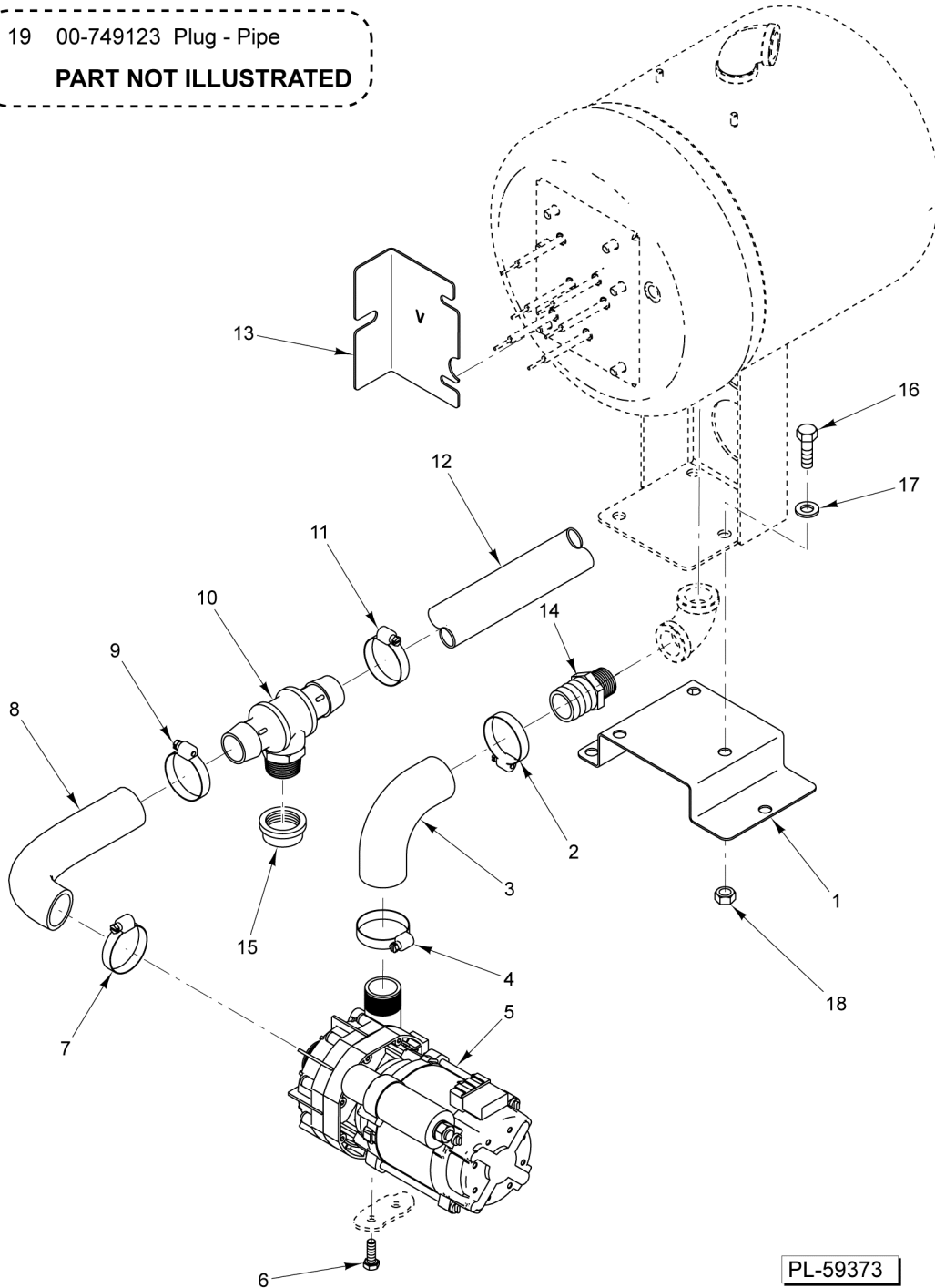

PL-59373

**RINSE PUMP ASSEMBLY
(ML-130153, ML-130154, & ML-130155)**

RINSE PUMP ASSEMBLY
(ML-130153, ML-130154, & ML-130155)

ILLUS. PL-59373	PART NO.	NAME OF PART	AMT.
1	00-941133	Mount - Booster Spacer.....	1
2	00-557627	Clamp - Hose.....	1
3	00-950423-00002	Hose - Pump-to-Booster.....	1
4	00-557627	Clamp - Hose.....	1
5	00-936994	Pump - Rinse (208-240 V., 60 Hz., 1 Ph.).....	1
6	SC-120-48	Cap Screw M6 x 1.0 x 18mm Hex Hd. (SST).....	2
7	00-557627	Clamp - Hose.....	1
8	00-918135	Hose - Drain Pump Inlet.....	1
9	00-557627	Clamp - Hose.....	1
10	00-941172	Tee - Branch (1 In. x 3/4 In.).....	1
11	00-557627	Clamp - Hose.....	2
12	00-936468-00003	Hose (1 In. x 15 In.).....	1
13	00-941148	Bracket - Ventless Booster Support.....	1
14	00-941149	Adapter - Hose (1/2 to 1 In.).....	1
15	FP-029-13	Cap - Pipe (3/4 In.) (Brass).....	1
16	SC-041-11	Cap Screw 5/16-18 x 3/4 Hex Hd. (SST).....	3
17	WS-017-01	Washer 0.328 x 0.875 x 0.062 (SST).....	3
18	NS-036-19	Stop Nut 5/16-18 Hex (SST).....	3
19	00-749123	Plug - Pipe.....	1

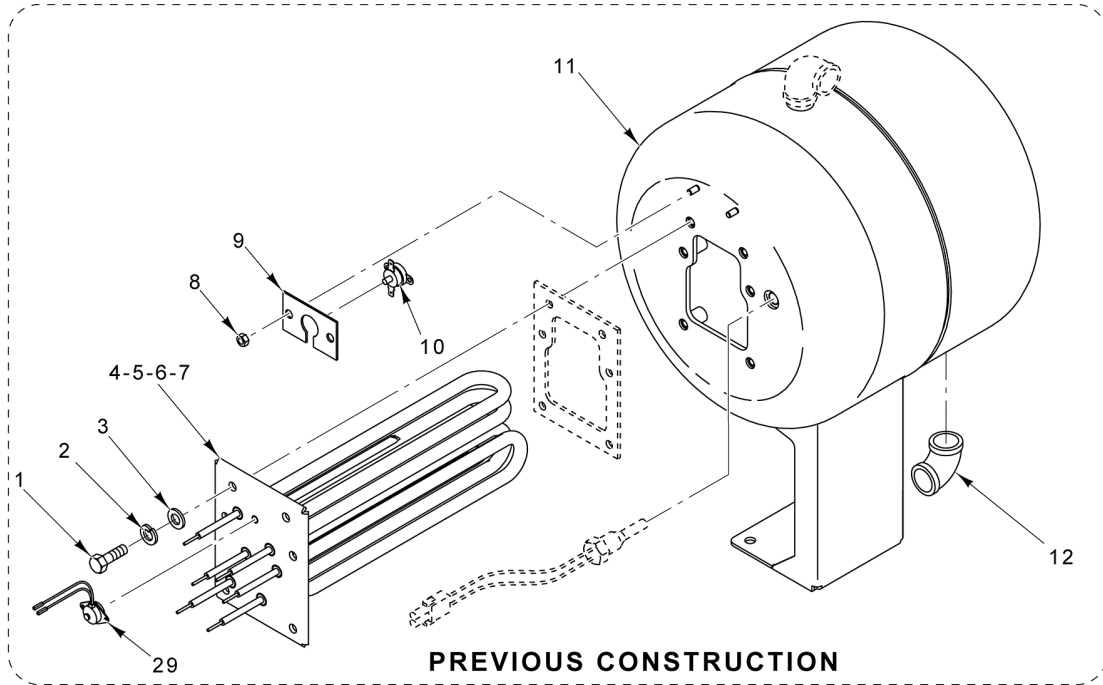

PREVIOUS CONSTRUCTION

30 00-519504 Thermo Joint Compound
PART NOT ILLUSTRATED

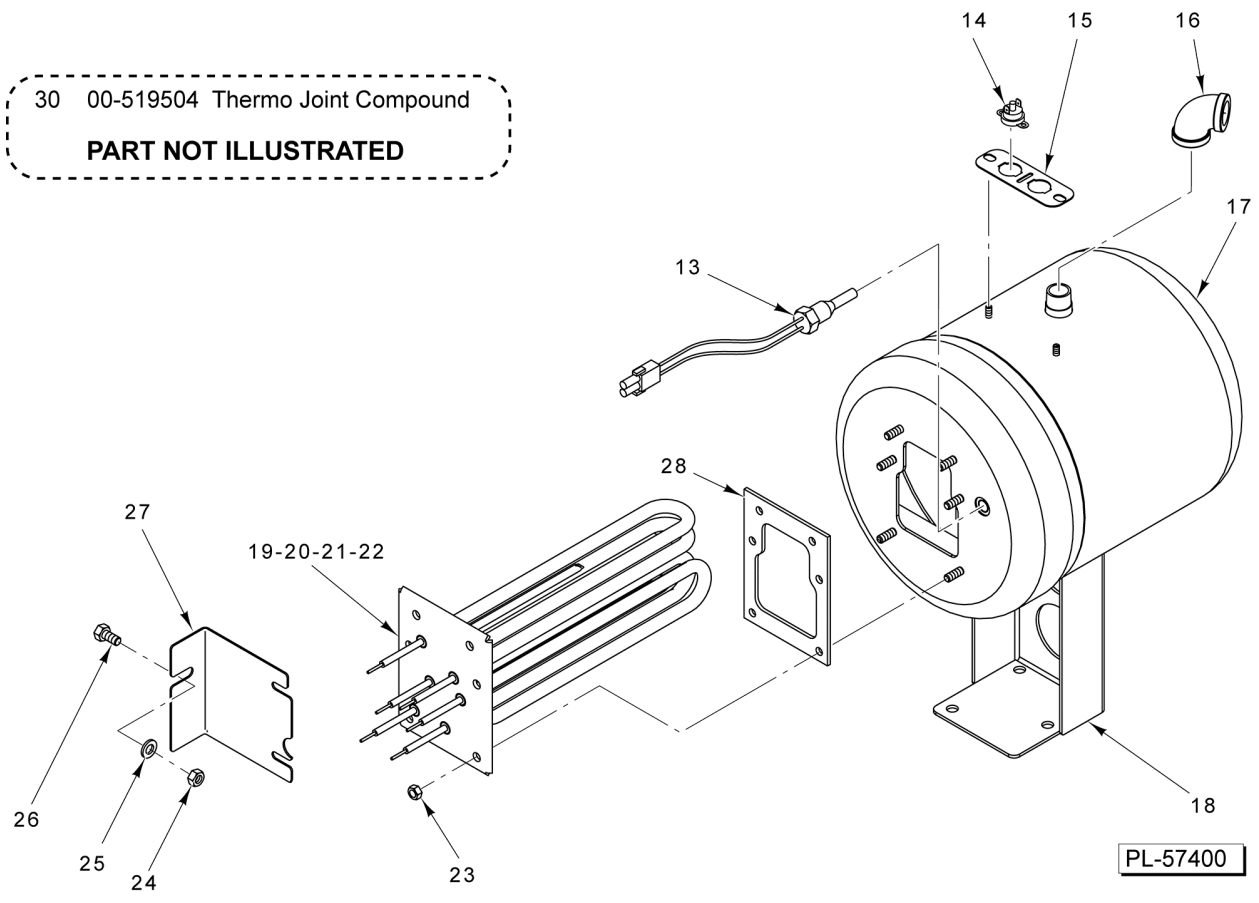

PL-57400

ELECTRIC BOOSTER TANK

ELECTRIC BOOSTER TANK

ILLUS.	PART NO.	NAME OF PART	AMT.
PL-57400			
1	SC-041-01	Cap Screw 1/4-20 x 3/4 Hex Hd. (SST).....	6
2	WL-006-17	Lockwasher 1/4 Helical (SST).....	6
3	WS-017-06	Washer (SST).....	6
4	00-749554-00002	Heater (13 kW) (240 V.).....	1
5	00-749554-00001	Heater (13 kW) (208 V.).....	1
6	00-749554-00003	Heater (13 kW) (480 V.).....	1
7	00-749554-00004	Heater (13 kW) (380 V.).....	1
8	NS-047-86	Stop Nut 1/4-20 Hex (SST).....	2
9	00-475967	Bracket - High Limit.....	1
10	00-294615-00001	Control - Temperature.....	1
11	00-893047	Tank - Weldment.....	1
12	FP-015-16	Elbow - Pipe 1/2 x 90 Deg. (Brass).....	1
13	00-328994	Probe Assy. - Rinse.....	1
14	00-328980-00001	Control - Temperature Limiting (AM15VL, AM15VLT, & AM15VLF).....	2
15	00-936851	Bracket - High Limit.....	1
16	FP-015-16	Elbow - Pipe 1/2 x 90 Deg. (Brass).....	1
17	00-919824	Tank - Booster Weldment.....	1
18	00-936862	Bracket - Booster Mounting.....	1
19	00-936546-00002	Heater (240 V., 8.5 kW).....	1
20	00-936546-00001	Heater (208 V., 8.5 kW).....	1
21	00-936546-00003	Heater (480 V., 8.5 kW) (AM15VL, AM15VLT, & AM15VLF).....	1
22	00-936546-00004	Heater (415 V., 8.5 kW) (AM15VL, AM15VLT, & AM15VLF).....	1
23	NS-014-01	Nut 1/4-20 Hex (Brass).....	6
24	NS-036-19	Stop Nut 5/16-18 Hex (SST).....	1
25	WS-017-01	Washer 0.328 x 0.875 x 0.062 (SST).....	1
26	SC-041-11	Cap Screw 5/16-18 x 3/4 Hex Hd. (SST).....	1
27	00-936852	Bracket - Booster Support.....	1
28	00-749555	Gasket (13 kW) (Electric Heater).....	1
29	00-271123	Protector - High Limit.....	1
30	00-519504	Thermo Joint Compound (2 Oz.).....	AR

- | | | |
|----|-----------------|-------------------------|
| 35 | 00-941119 | Shroud - Front |
| 36 | 00-941176 | Box - Light |
| 37 | 00-941175-00003 | Light - Indicator Amber |
| 38 | 00-941283 | Resistor |

PARTS NOT ILLUSTRATED

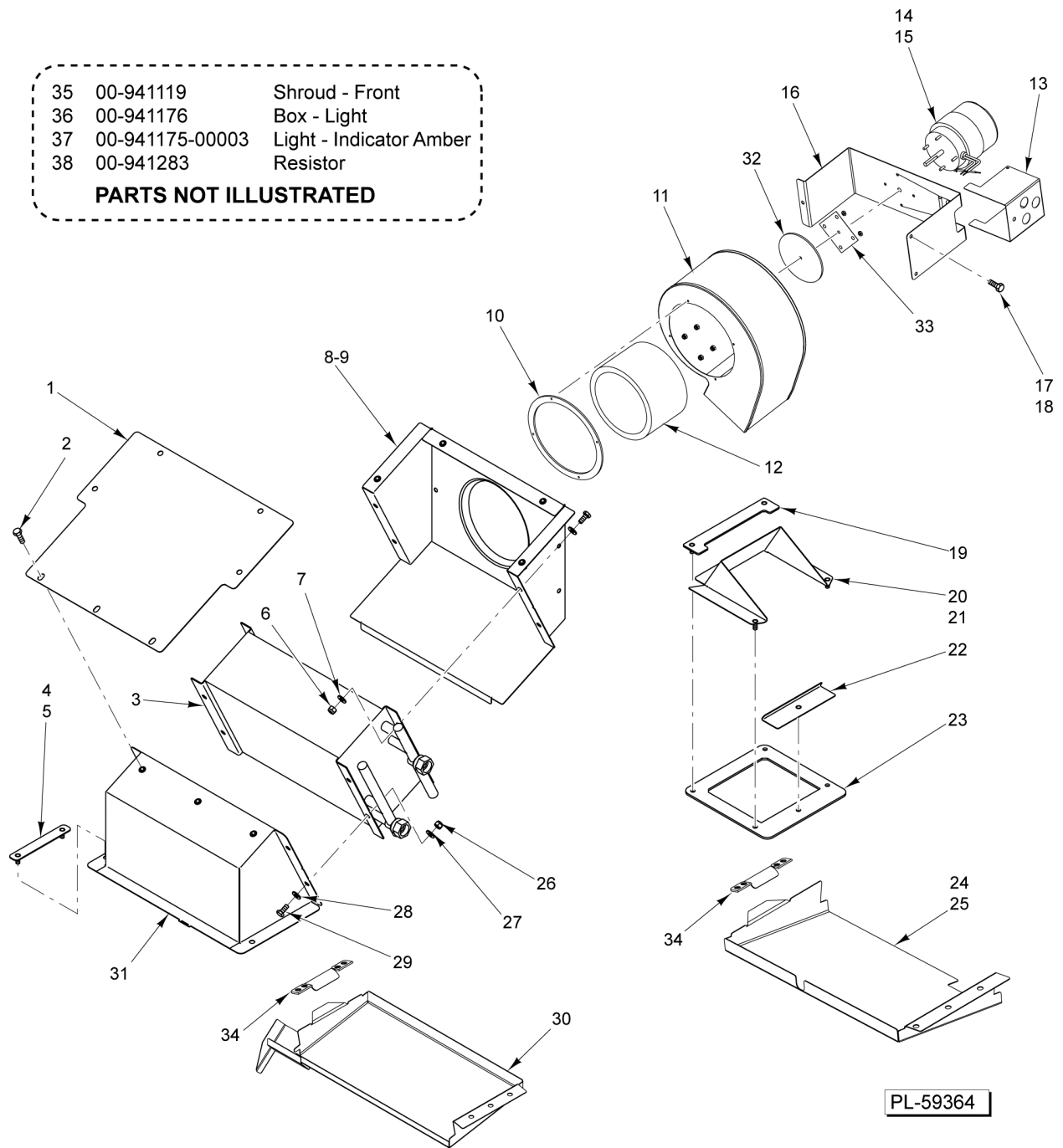

STEAM CONDENSER

STEAM CONDENSER

ILLUS. PL-59364	PART NO.	NAME OF PART	AMT.
1	00-941160	Plate - Ventless Top.....	1
2	SC-041-05	Cap Screw 1/4-20 x 5/8 Hex Hd. (SST).....	7
3	00-941113	Coil - Steam Condensing.....	1
4	00-941188	Bracket - Intake Plenum.....	1
5	NS-047-82	Stop Nut 1/4-20 Hex (SST).....	2
6	NS-047-82	Stop Nut 1/4-20 Hex (SST).....	AR
7	WS-017-06	Washer (SST).....	AR
8	00-941159	Mount - Ventless Fan To Coil.....	1
9	00-526454-00002	Foam Tape.....	AR
10	00-941197-00001	Gasket - Fan Intake.....	1
11	00-941200-00002	Housing - Fan.....	1
12	00-941200-00003	Impeller - Fan.....	1
13	00-941183	Cover - Fan Motor.....	1
14	00-941187	Motor - Fan.....	2
15	00-941197-00002	Gasket - Motor.....	1
16	00-941184	Mount - Fan Motor.....	1
17	SC-041-05	Cap Screw 1/4-20 x 5/8 Hex Hd. (SST).....	3
18	NS-047-82	Stop Nut 1/4-20 Hex (SST).....	3
19	00-941232	Plate - Corner Reinforcement.....	1
20	00-941182	Seal - Fan Mount.....	1
21	NS-047-82	Stop Nut 1/4-20 Hex (SST).....	5
22	00-941189	Mount - Adjusting Fan.....	1
23	00-941229	Gasket - Exhaust Fan.....	1
24	00-941354	Deflector - Exhaust.....	1
25	NS-047-82	Stop Nut 1/4-20 Hex (SST).....	8
26	NS-047-82	Stop Nut 1/4-20 Hex (SST).....	4
27	WS-017-06	Washer (SST).....	4
28	WS-017-06	Washer (SST).....	4
29	SC-041-05	Cap Screw 1/4-20 x 5/8 Hex Hd. (SST).....	4
30	00-941443	Deflector - Ventless Intake Assy.....	1
31	00-941163	Plenum - Ventless Intake.....	1
32	00-941197-00002	Gasket - Motor.....	1
33	00-948690	Seal - Fan Shaft.....	1
34	00-941349	Bracket - Baffle.....	2
35	00-941119	Shroud - Front.....	1
36	00-941176	Box - Light.....	1
37	00-941175-00003	Light - Indicator Amber (Incls. Resistor).....	1
38	00-941283	Resistor.....	1

- 26 00-186091 Probe & Float Assy.
- 27 00-519504 Thermo Joint Compound

PARTS NOT ILLUSTRATED

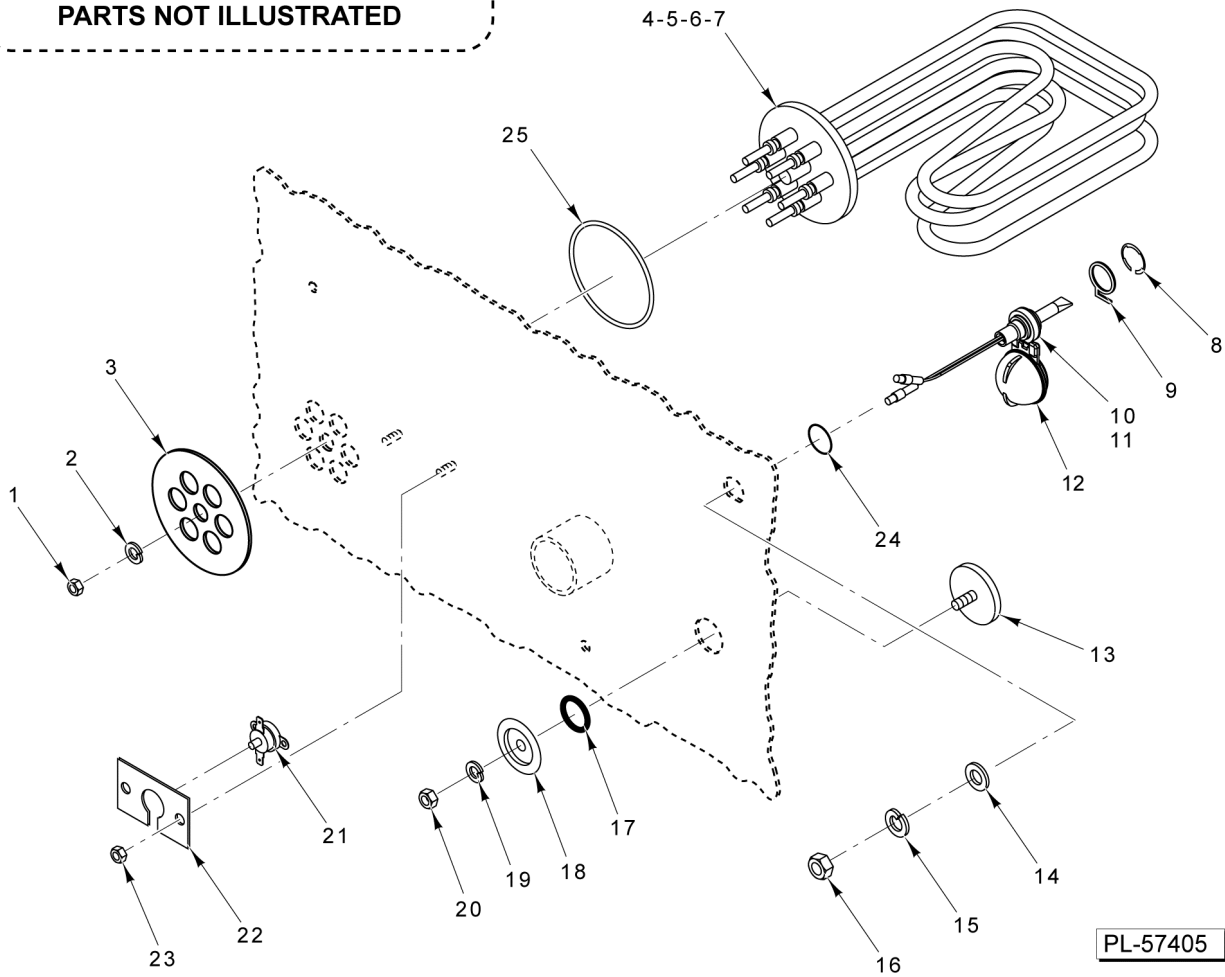

PL-57405

LOW WATER PROTECTION AND ELECTRIC HEAT

LOW WATER PROTECTION AND ELECTRIC HEAT

ILLUS. PL-57405	PART NO.	NAME OF PART	AMT.
1	NS-014-15	Nut 3/8-16 (Brass) (Supplied With Heater).....	1
2	WL-006-27	Lockwasher 3/8 Helical (SST).....	1
3	00-749798	Plate - Electric Heat.....	1
4	00-893120-00004	Element - Heater (6.2 kW) (208 V.).....	AR
5	00-893120-00001	Element - Heater (5 kW) (200-240 V., 50/60 Hz., 1 & 3 Ph.).....	1
6	00-893120-00002	Element - Heater (5 kW) (480 V., 60 Hz., 3 Ph.).....	1
7	00-893120-00003	Element - Heater (5 kW) (380-415 V., 50 Hz., 3 Ph.).....	1
8	RR-010-13	Retaining Ring.....	1
9	00-112467	Retainer - Float.....	1
10	00-271621	Probe & Switch Assy. (4 Wire) (Temperatures & Water Level) (Previous Construction)	1
11	00-936547-00002	Switch & Probe Assy. (4-Wire) (Short) (Incls. Items 9 & 12) (Current Construction)	1
12	00-122674	Float Assy.....	1
13	00-119244	Cap & Stud Assy.....	1
14	WS-010-40	Washer - Thrust.....	1
15	WL-014-31	Lockwasher 1/2 External Shakeproof (SST).....	1
16	NS-018-28	Jam Nut 1/2-20 Hex (SST).....	1
17	00-067500-00031	O-Ring.....	1
18	00-119254-00002	Retainer - Cap.....	1
19	WL-006-17	Lockwasher 1/4 Helical (SST).....	1
20	NS-015-01	Nut 1/4-20 Hex (SST).....	1
21	00-294615-00001	Control - Temperature.....	1
22	00-475967	Bracket - High Limit.....	1
23	NS-031-16	Stop Nut 10-24 Hex Elastic (SST).....	2
24	00-067500-00072	O-Ring.....	1
25	00-067500-00034	O-Ring.....	1
26	00-186091	Probe & Float Assy. (Incls. Items 8 thru 10 & 12) (Previous Construction).....	1
27	00-519504	Thermo Joint Compound (2 Oz.).....	AR

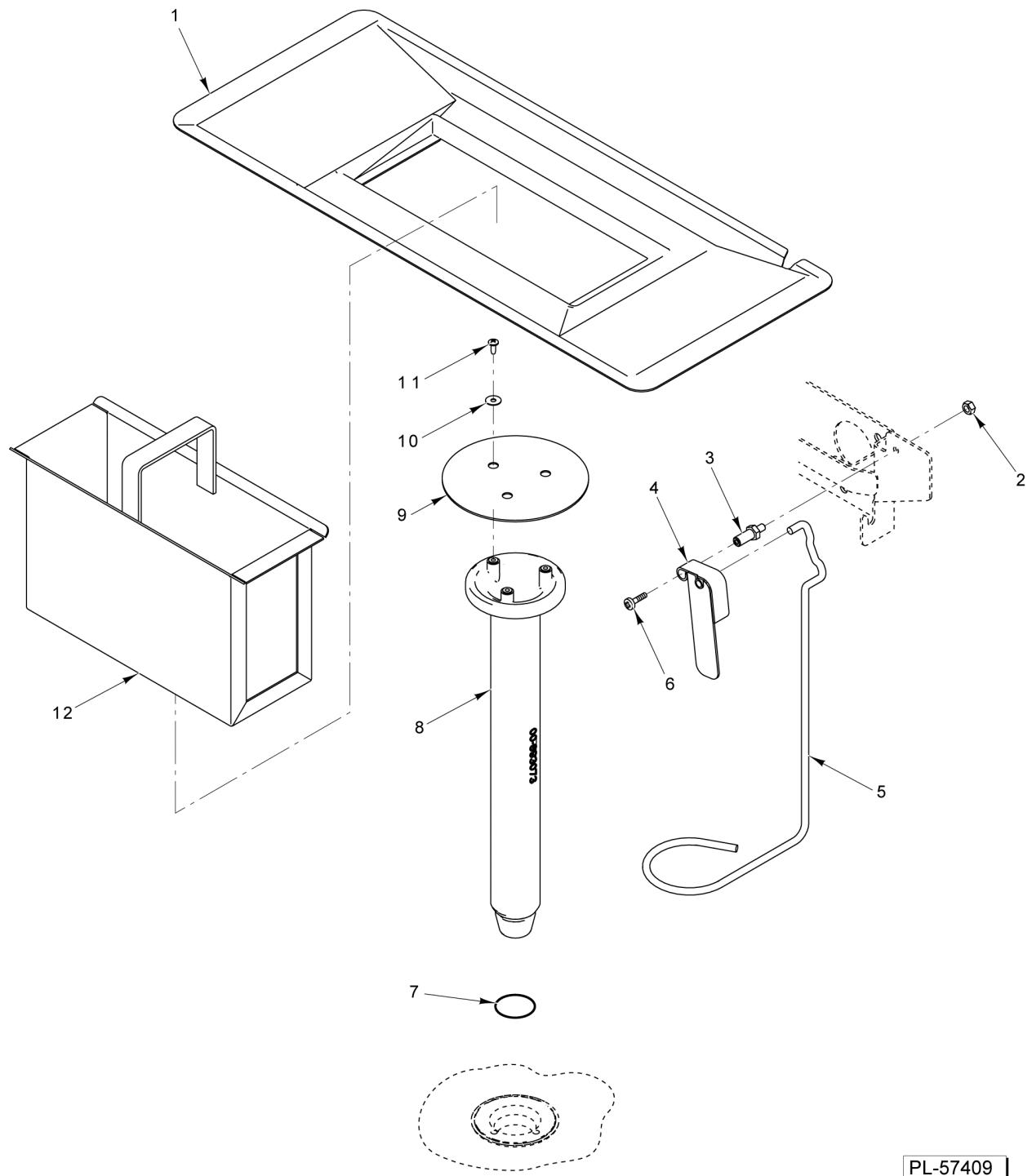

PL-57409

DRAIN UNIT

DRAIN UNIT

ILLUS.	PART NO.	NAME OF PART	AMT.
PL-57409			
1	00-893045	Strainer Pan.....	1
2	NS-047-82	Stop Nut 1/4-20 Hex (SST).....	1
3	00-119116	Axle - Drain Lever.....	1
4	00-893091	Drain Lever Assy.....	1
5	00-893095	Drain - Lift.....	1
6	SC-066-06	Mach. Screw 10-24 x 1/2 Phil. Truss Hd. (SST).....	1
7	00-067500-00120	O-Ring.....	1
8	00-893071	Drain Tube Assy. (Incls. Items 9, 10, & 11).....	1
9	00-893072	Cover - Standpipe.....	1
10	WS-019-33	Washer.....	3
11	SD-038-84	Self-Tapping Screw 10-24 x 1/2 Phil. Truss Hd., Type F (SST).....	3
12	00-118999	Strainer Basket Assy.....	1

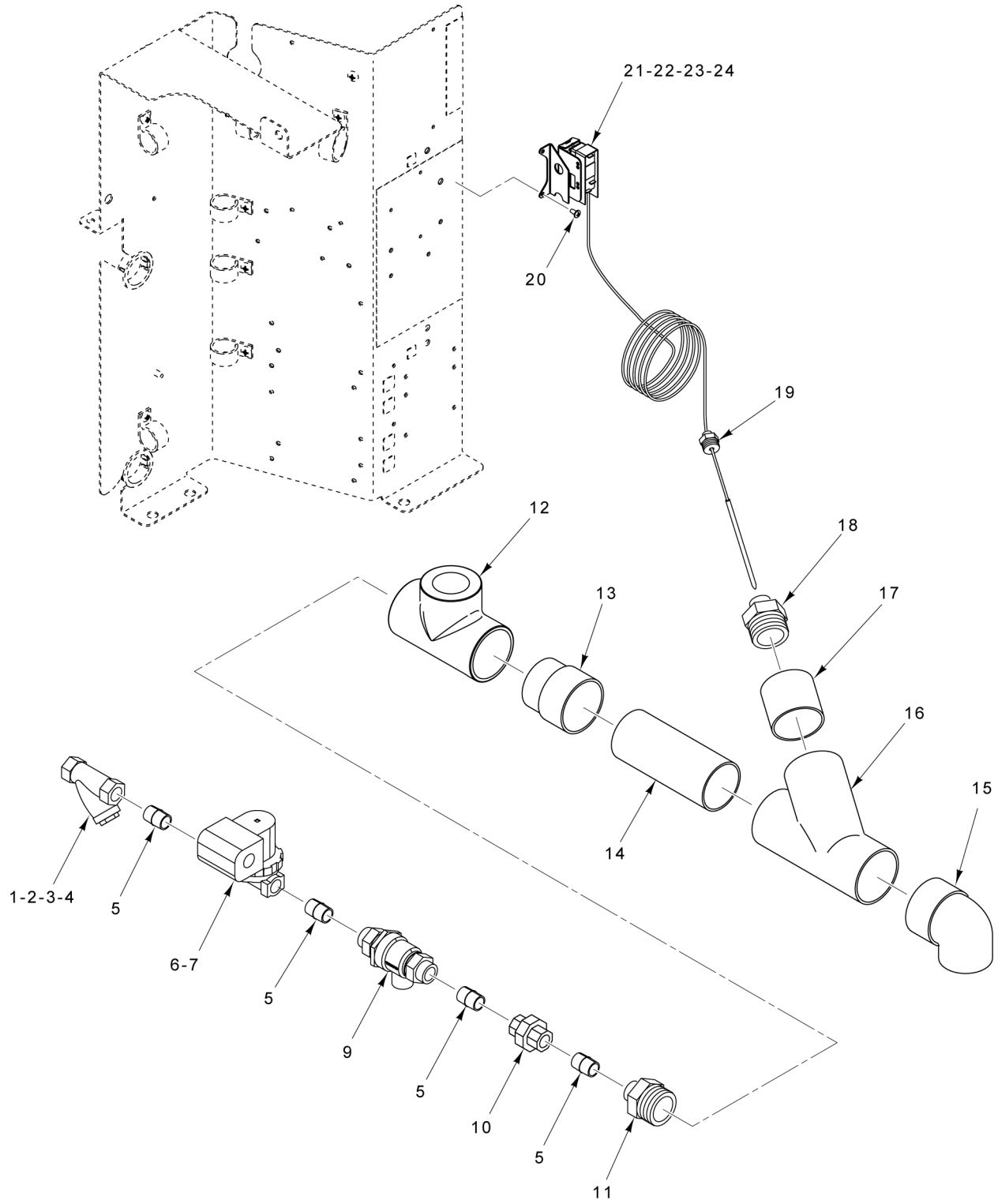

PL-60358

DRAIN WATER TEMPERING

DRAIN WATER TEMPERING

ILLUS.	PART NO.	NAME OF PART	AMT.
PL-60358			
1	00-270258	Strainer - Line (1/2) (Brass) (Incls. Items 2, 3, & 4).....	1
2	00-270259	Plug - Branch.....	1
3	00-270260	Screen - Strainer (1/2 In.).....	1
4	00-270261	Gasket.....	1
5	FP-040-42	Pipe 1/2 x 1-1/8 TBE (Brass).....	4
6	00-936121	Valve - Solenoid (1/2) (120 V.).....	1
7	00-936283	Coil - Solenoid Valve (120 V.).....	1
9	00-223472	Backflow Preventer.....	1
10	FP-022-12	Union - Pipe (Brass).....	1
11	FP-027-45	Adapter 1-1/2 Brass to 1/2 FPT.....	1
12	FP-091-03	Tee 1-1/2 x 1-1/2 x 1-1/2 (CPVC).....	1
13	00-893860	Adapter - Male 1-1/2 (CPVC).....	1
14	00-936260-00002	Pipe 1-1/2 x 2-1/2 (CPVC).....	1
15	FP-091-05	Elbow 1-1/2 x 90 Deg. (CPVC).....	1
16	FP-091-06	Y-Fitting 1-1/2 (CPVC).....	1
17	00-936260-00001	Pipe 1-1/2 x 6 (CPVC).....	1
18	FP-091-04	Adapter 1-1/2 CPVC to 1 FPT.....	1
19	FP-077-44	Bushing - Pipe 1 to 3/8.....	1
20	SD-008-18	Self-Tapping Screw 8-18 x 3/8 Phil. Bndg. Hd., Type B.....	2
21	00-294681-25-03	Thermostat (120 Deg.).....	1
22	00-936293-00001	Cable Assy.....	1
23	00-936332-00001	Wire (Transformer to Thermostat).....	1
24	00-083376	Wire Tie.....	AR

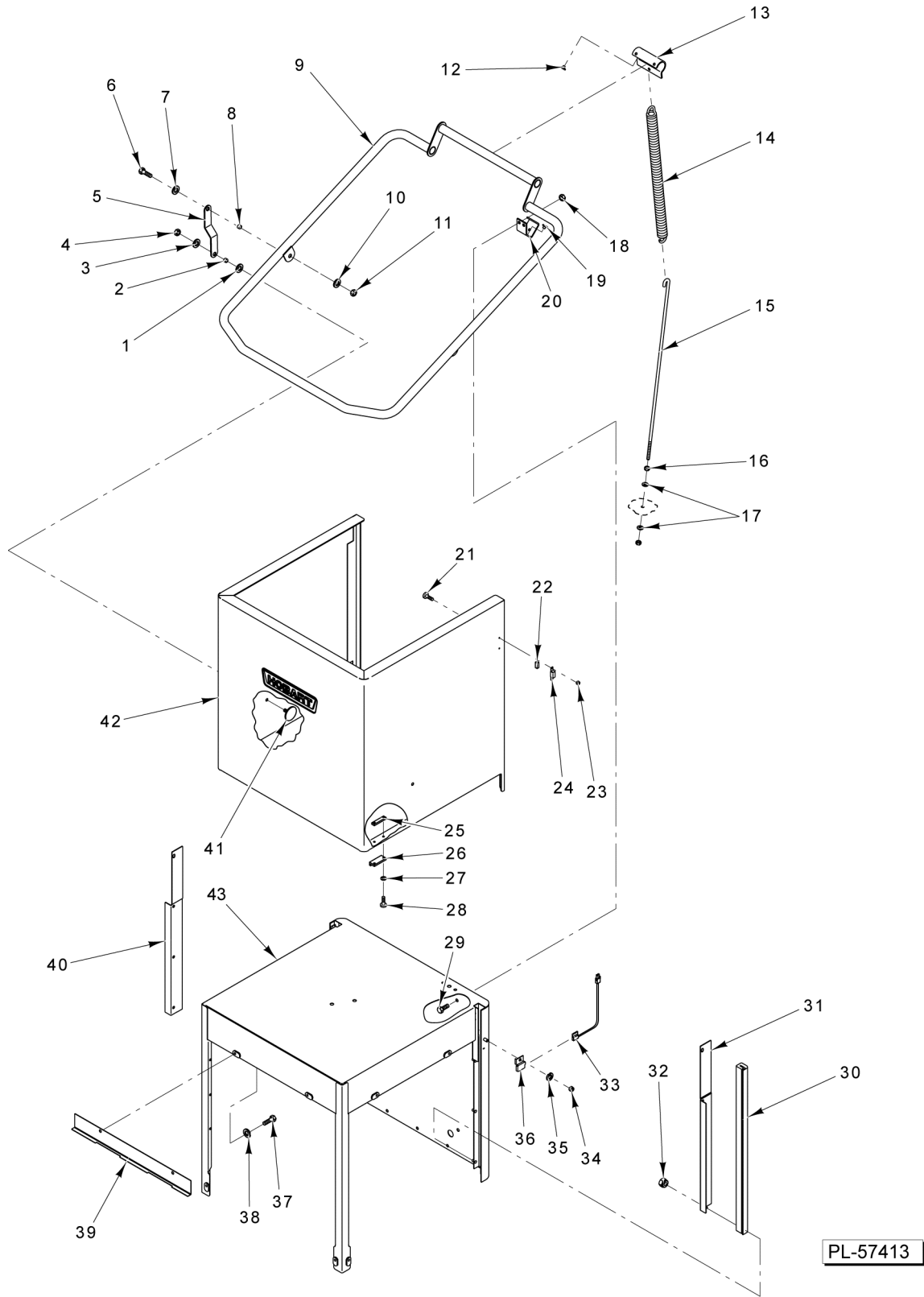

**DOOR ASSEMBLY
(AM15 & AM15VL)**

**DOOR ASSEMBLY
(AM15 & AM15VL)**

ILLUS. PL-57413	PART NO.	NAME OF PART	AMT.
1	WS-017-01	Washer 0.328 x 0.875 x 0.062 (SST).....	2
2	00-893014-00002	Spacer - Door Link (Lower).....	2
3	WS-017-01	Washer 0.328 x 0.875 x 0.062 (SST).....	2
4	NS-036-19	Stop Nut 5/16-18 Hex (SST).....	2
5	00-893252	Link - Door Handle.....	2
6	SC-041-12	Cap Screw 5/16-18 x 7/8 Hex Hd. (SST).....	2
7	WS-017-01	Washer 0.328 x 0.875 x 0.062 (SST).....	2
8	00-893014-00001	Spacer Door Link (Upper).....	2
9	00-893051	Handle - Weldment.....	1
10	WS-017-01	Washer 0.328 x 0.875 x 0.062 (SST).....	2
11	NS-036-19	Stop Nut 5/16-18 Hex (SST).....	2
12	00-119055	Button - Bearing.....	4
13	00-893011	Hanger - Counterbalance (Spring).....	1
14	00-893012	Spring - Extension (Door).....	1
15	00-893013	Hook - Spring.....	1
16	NS-015-11	Nut 5/16-18 Hex (SST).....	3
17	WS-017-01	Washer 0.328 x 0.875 x 0.062 (SST).....	2
18	NS-036-19	Stop Nut 5/16-18 Hex (SST).....	4
19	00-119055	Button - Bearing.....	4
20	00-893224	Support - Handle.....	2
21	SC-066-01	Mach. Screw 6-32 x 1/4 Phil. Truss Hd.....	2
22	00-111941	Magnet.....	1
23	NS-031-50	Stop Nut 6-32 Hex (SST).....	2
24	00-893111	Magnet - Mount.....	1
25	00-893826	Door Guide Mount.....	2
26	00-893801	Spacer - Door Guide.....	2
27	WS-023-01	Washer (SST).....	4
28	SC-066-02	Mach. Screw 6-32 x 3/8 Phil. Truss Hd. (SST).....	4
29	SC-041-09	Cap Screw 5/16-18 x 1/2 Hex Hd. (SST).....	4
30	00-918458-00001	Guide - Door.....	2
31	00-893201-00002	Cover - Door Guide (RH).....	1
32	NS-047-82	Stop Nut 1/4-20 Hex (SST).....	4
33	00-473109-00004	Switch Assy. - Door.....	1
34	NS-015-11	Nut 5/16-18 Hex (SST).....	1
35	WL-006-23	Lockwasher 5/16 Helical (SST).....	1
36	00-893853	Bracket - Reed Switch Mounting.....	1
37	SC-041-11	Cap Screw 5/16-18 x 3/4 Hex Hd. (SST).....	6
38	WL-006-23	Lockwasher 5/16 Helical (SST).....	6
39	00-893015	Stop - Door.....	3
40	00-893201	Cover - Door Guide (LH).....	1
41	00-893226	Stiffener - Door Plate.....	2
42	00-893202	Door Wrap.....	1
43	00-893196	Chamber - Weldment (Upper) (Standard Height).....	1

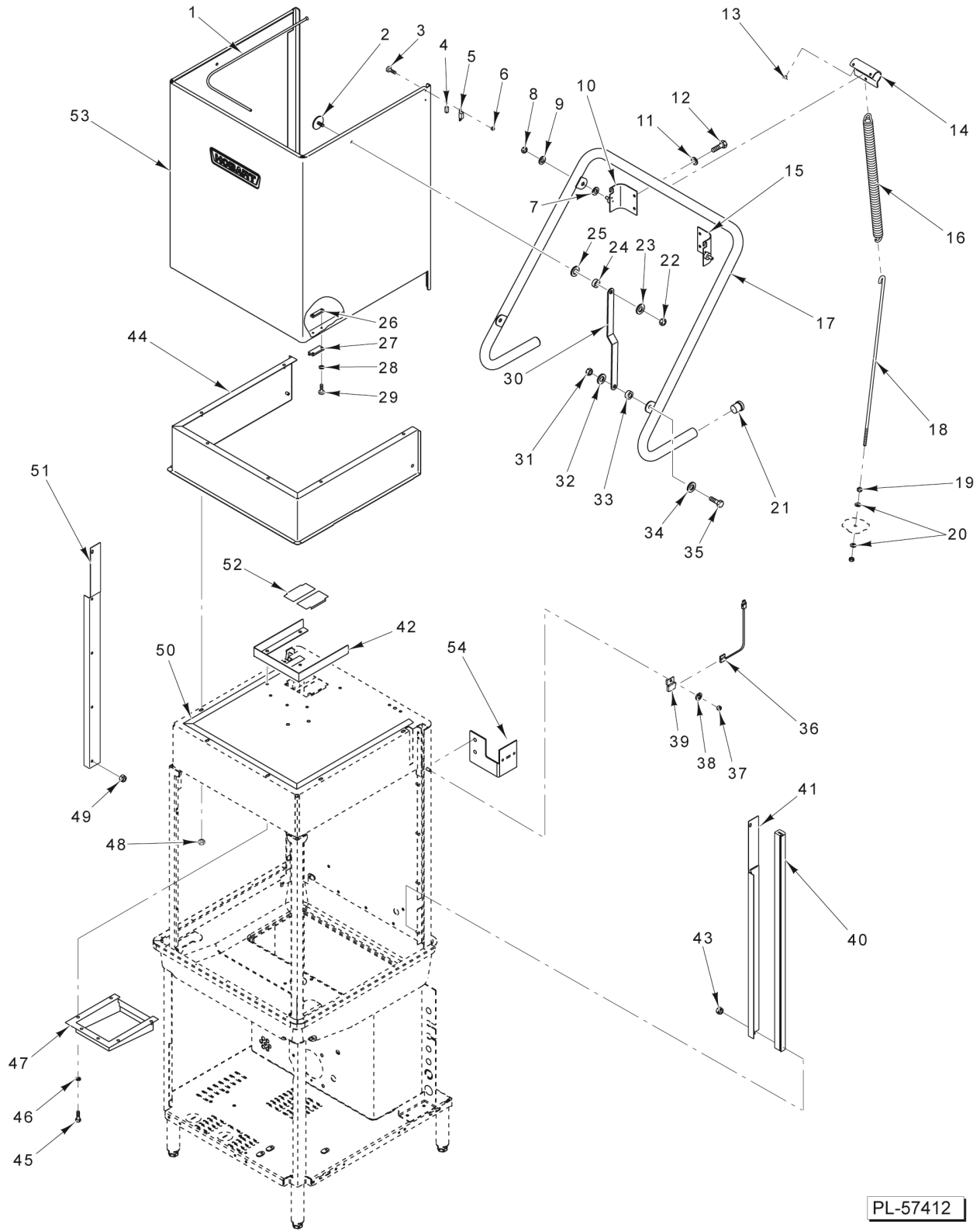

PL-57412

**DOOR ASSEMBLY
(AM15T, AM15F, AM15VLT, & AM15VLF)**

DOOR ASSEMBLY
(AM15T, AM15F, AM15VLT, & AM15VLF)

ILLUS. PL-57412	PART NO.	NAME OF PART	AMT.
1	00-893834	Seal - Top Cover (Tall).....	3
2	00-893226	Stiffener - Door Plate.....	2
3	SC-066-01	Mach. Screw 6-32 x 1/4 Phil. Truss Hd.....	4
4	00-111941	Magnet.....	1
5	00-893111	Magnet - Mount.....	1
6	NS-031-50	Stop Nut 6-32 Hex (SST).....	2
7	WS-017-01	Washer 0.328 x 0.875 x 0.062 (SST).....	2
8	NS-036-19	Stop Nut 5/16-18 Hex (SST).....	2
9	WS-017-01	Washer 0.328 x 0.875 x 0.062 (SST).....	2
10	00-893486-00002	Bracket - Handle (LH).....	1
11	WL-006-23	Lockwasher 5/16 Helical (SST).....	4
12	SC-041-09	Cap Screw 5/16-18 x 1/2 Hex Hd. (SST).....	4
13	00-119055	Button - Bearing.....	4
14	00-893500	Hanger - Counterbalance (Spring).....	1
15	00-893486-00001	Bracket - Handle (RH).....	1
16	00-893498	Spring - Extension (Door).....	1
17	00-893484	Handle - Weldment.....	1
18	00-893013-00002	Hook - Spring.....	1
19	NS-015-11	Nut 5/16-18 Hex (SST).....	3
20	WS-017-01	Washer 0.328 x 0.875 x 0.062 (SST).....	2
21	00-918049	Plug - Lift Arm.....	2
22	NS-036-19	Stop Nut 5/16-18 Hex (SST).....	2
23	WS-017-01	Washer 0.328 x 0.875 x 0.062 (SST).....	2
24	00-893014-00001	Spacer Door Link (Upper).....	2
25	WS-017-01	Washer 0.328 x 0.875 x 0.062 (SST).....	2
26	00-893826	Door Guide Mount.....	2
27	00-893801	Spacer - Door Guide.....	2
28	WS-023-01	Washer (SST).....	4
29	SC-066-02	Mach. Screw 6-32 x 3/8 Phil. Truss Hd. (SST).....	4
30	00-893487	Link - Door Handle.....	2
31	NS-036-19	Stop Nut 5/16-18 Hex (SST).....	2
32	WS-017-01	Washer 0.328 x 0.875 x 0.062 (SST).....	2
33	00-893014-00003	Spacer - Door Link.....	2
34	WS-017-01	Washer 0.328 x 0.875 x 0.062 (SST).....	2
35	SC-041-12	Cap Screw 5/16-18 x 7/8 Hex Hd. (SST).....	2
36	00-473109-00004	Switch Assy. - Door.....	1
37	NS-015-11	Nut 5/16-18 Hex (SST).....	1
38	WL-006-23	Lockwasher 5/16 Helical (SST).....	1
39	00-893853	Bracket - Reed Switch Mounting.....	1
40	00-918458-00004	Guide - Door (Tall).....	2
41	00-893314-00002	Cover - Door Guide (RH).....	1
42	00-893946	Vent - Deflector (AM15T & AM15F).....	1
43	NS-047-82	Stop Nut 1/4-20 Hex (SST).....	5
44	00-893320	Cover Assy. - Top Chamber.....	1
45	SC-041-09	Cap Screw 5/16-18 x 1/2 Hex Hd. (SST).....	6
46	WL-006-23	Lockwasher 5/16 Helical (SST).....	6
47	00-918166	Vent Assy. - Inside Deflector (AM15T & AM15F).....	1
48	NS-047-82	Stop Nut 1/4-20 Hex (SST).....	6
49	NS-047-82	Stop Nut 1/4-20 Hex (SST).....	5
50	00-526408	Tape - Foam.....	AR
51	00-893314	Cover - Door Guide (LH).....	1
52	00-893956	Cap - Vent (AM15T & AM15F).....	2
53	00-893326	Door Wrap.....	1
54	00-941135	Tubing - Bracket (AM15VLT Only).....	1

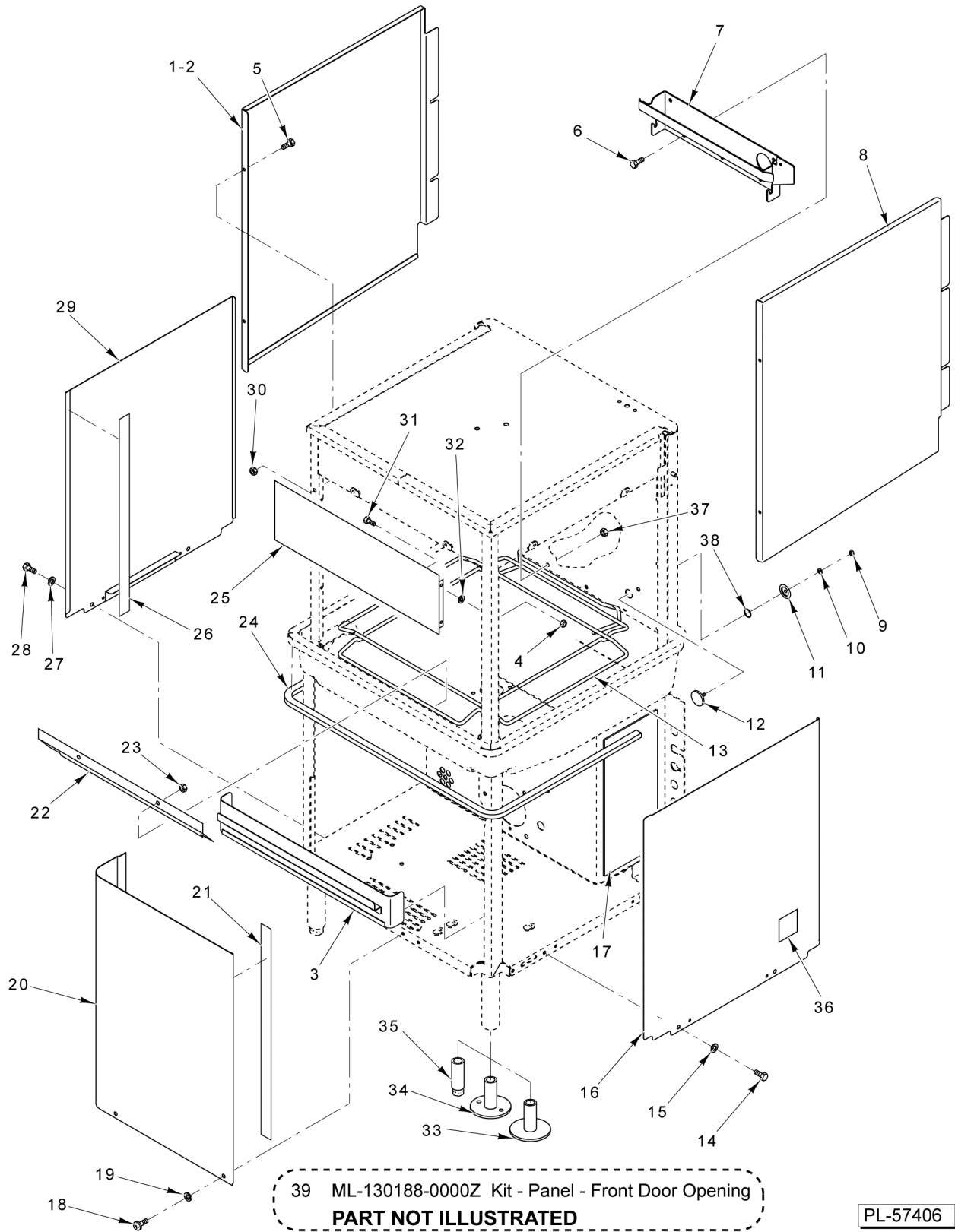

PANELS AND RACK SUPPORT

PANELS AND RACK SUPPORT

ILLUS. PL-57406	PART NO.	NAME OF PART	AMT.
1	00-893843	Kit - Splash Panel (AM15 & AM15VL).....	1
2	00-893119-00002	Kit - Splash Panel (AM15T, AM15F, AM15VLT, & AM15VLF).....	1
3	00-936710	Shield - Splash.....	1
4	NS-047-82	Stop Nut 1/4-20 Hex (SST).....	4
5	SC-059-29	Cap Screw 1/4-20 x 1/2 Hex Socket Hd. (SST).....	2
6	SC-041-10	Cap Screw 5/16-18 x 5/8 Hex Hd. (SST).....	5
7	00-893798	Rack - Stop Assy.....	1
8	00-936234	Panel - Splash (RH) (AM15T, AM15F, AM15VLT, & AM15VLF).....	1
9	NS-015-01	Nut 1/4-20 Hex (SST).....	1
10	WL-006-17	Lockwasher 1/4 Helical (SST).....	1
11	00-119254-00002	Retainer - Cap.....	1
12	00-119244	Cap & Stud Assy.....	1
13	00-893790-00001	Wireform Assy.....	1
14	SC-041-50	Cap Screw 1/4-20 x 1/2 Hex Hd. (SST).....	2
15	WL-006-17	Lockwasher 1/4 Helical (SST).....	2
16	00-893042	Panel - Cover (Right Side).....	1
17	00-918097	Kit - Foam Installation.....	AR
18	SC-125-15	Mach. Screw 1/4-20 x 1/2 Phil. Truss Hd.....	2
19	WL-006-17	Lockwasher 1/4 Helical (SST).....	2
20	00-893041	Panel - Cover (Front).....	1
21	00-526454	Foam Tape.....	AR
22	00-893069	Baffle - Steam.....	1
23	NS-036-19	Stop Nut 5/16-18 Hex (SST).....	2
24	00-893021	Seal - Extrusion.....	AR
25	00-893775	Deflector.....	1
26	00-526454	Foam Tape.....	AR
27	WL-006-17	Lockwasher 1/4 Helical (SST).....	2
28	SC-041-50	Cap Screw 1/4-20 x 1/2 Hex Hd. (SST).....	2
29	00-893018	Panel - Cover (Left Side).....	1
30	NS-047-82	Stop Nut 1/4-20 Hex (SST).....	2
31	SC-059-29	Cap Screw 1/4-20 x 1/2 Hex Socket Hd. (SST).....	4
32	WS-017-06	Washer (SST).....	4
33	00-893122-00002	Foot - Flanged (Without Holes).....	4
34	00-893122-00001	Foot - Flanged (With Holes).....	4
35	00-893122-00003	Foot - Standard.....	4
36	00-438131-061-2	Label - Warning (California).....	1
37	NS-036-19	Stop Nut 5/16-18 Hex (SST).....	5
38	00-067500-00031	O-Ring.....	1
39	ML-130188-0000Z	Kit - Panel - Front Door Opening (AM15 & AM15VL) (Pass thru Machines).....	1

21 00-893896-00001 Gas Piping Assy. (NAT)
 22 00-893896-00002 Gas Piping Assy. (LP)
PARTS NOT ILLUSTRATED

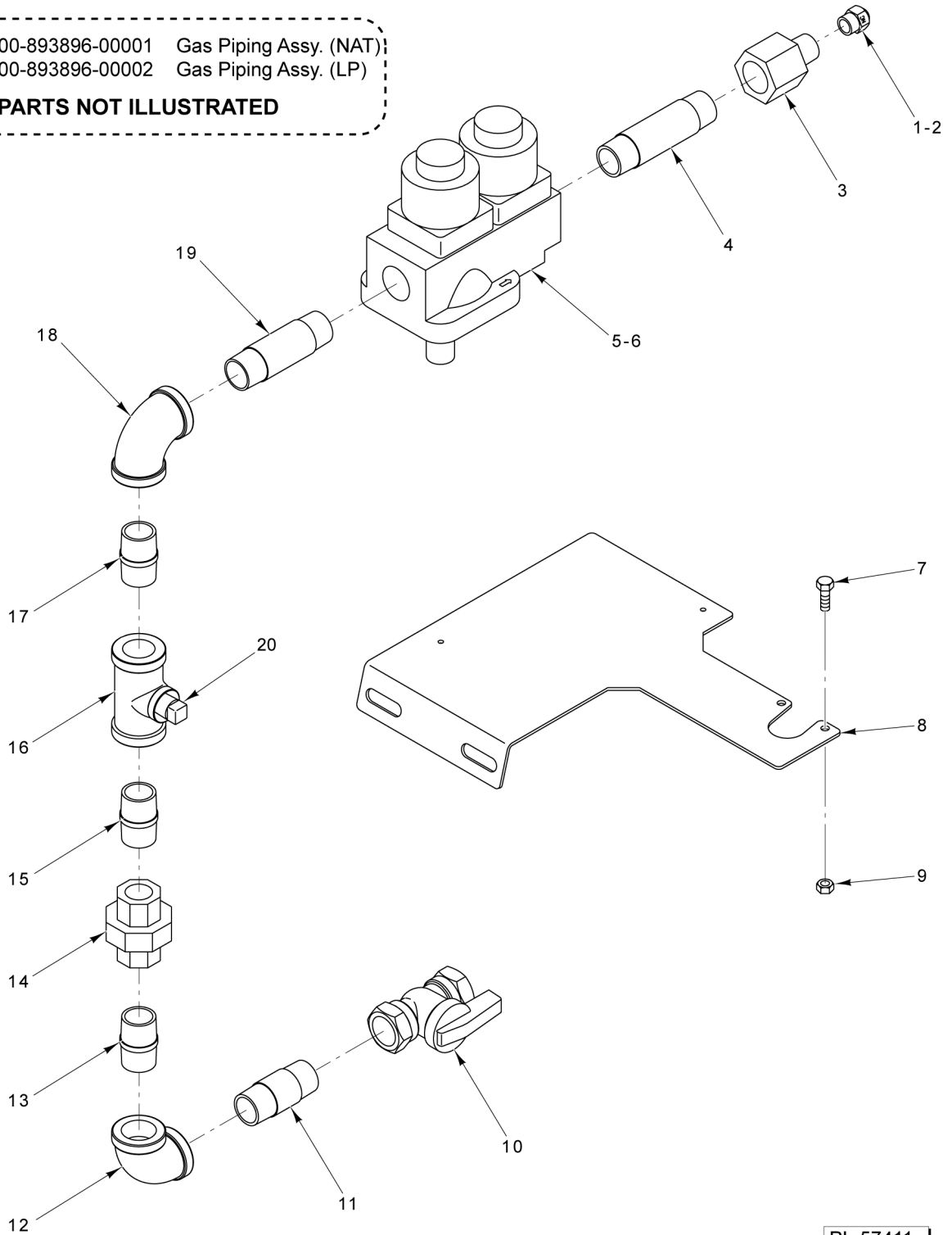

PL-57411

GAS HEAT PIPING

GAS HEAT PIPING

ILLUS.	PART NO.	NAME OF PART	AMT.
PL-57411			
1	00-893149-00001	Orifice (NAT).....	1
2	00-893149-00002	Orifice (LP).....	1
3	00-893132	Adapter 1/2 to 7/16-20.....	1
4	FP-059-10	Pipe 1/2 x 3 TBE.....	1
5	00-328426-00004	Valve - Regulator (NAT).....	1
6	00-328426-00005	Valve - Regulator (LP).....	1
7	SC-041-10	Cap Screw 5/16-18 x 5/8 Hex Hd. (SST).....	3
8	00-893895	Bracket - Ignitor Board.....	1
9	NS-015-11	Nut 5/16-18 Hex (SST).....	3
10	00-291988-00003	Valve - Gas (Shut Off).....	1
11	FP-067-04	Pipe 1/2 x 1-7/8 TBE.....	1
12	FP-013-15	Elbow - Pipe 1/2 x 90 Deg.....	1
13	FP-067-04	Pipe 1/2 x 1-7/8 TBE.....	1
14	FP-022-11	Union - Pipe.....	1
15	FP-067-04	Pipe 1/2 x 1-7/8 TBE.....	1
16	FP-084-31	Tee Pipe 1/2 x 1/2 x 1/4.....	1
17	FP-035-94	Pipe 1/2 x 1-1/2 TBE.....	1
18	FP-013-15	Elbow - Pipe 1/2 x 90 Deg.....	1
19	FP-036-97	Pipe 1/2 x 2-3/4 TBE.....	1
20	FP-028-06	Pipe Plug 1/4 Sq. Hd.....	1
21	00-893896-00001	Gas Piping Assy. (NAT) (Incls. Items 1, 3, 4, 5, & 10 thru 20).....	1
22	00-893896-00002	Gas Piping Assy. (LP) (Incls. Items 2, 3, 4, 6, & 10 thru 20).....	1

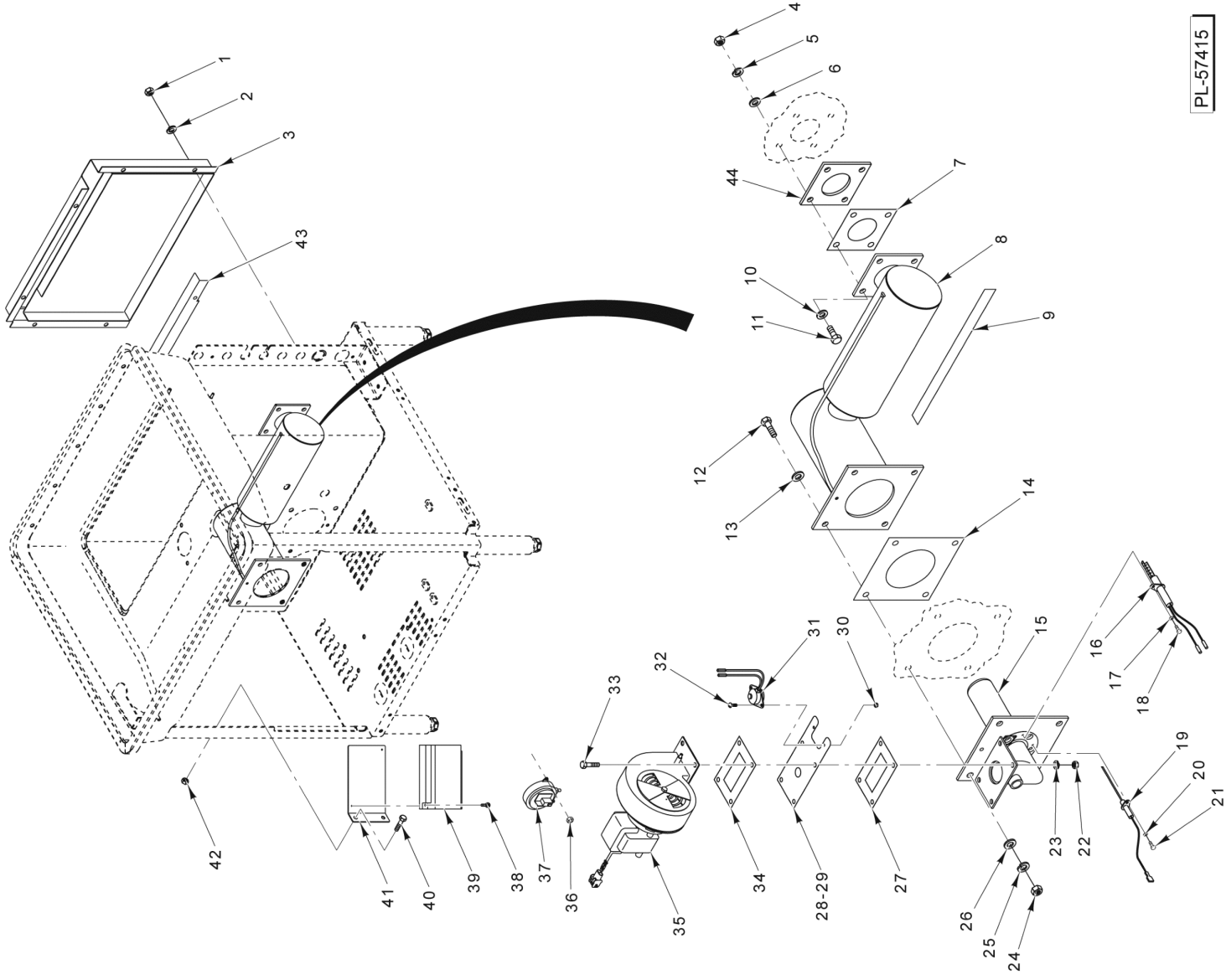

PL-57415

GAS HEAT COMPONENTS

GAS HEAT COMPONENTS

ILLUS.	PART NO.	NAME OF PART	AMT.
PL-57415			
1	NS-031-21	Stop Nut 1/4-20 Hex (SST).....	6
2	WL-014-10	Lockwasher 1/4 External Shakeproof.....	6
3	00-893890	Shroud - Exhaust.....	1
4	00-893039-00012	Nut 3/8-16 Hex (SST).....	4
5	WL-006-28	Lockwasher 3/8 Helical.....	4
6	WS-028-22	Washer.....	4
7	00-893892	Gasket - Immersion Tube.....	1
8	00-893879	Tube - Immersion.....	1
9	00-893900	Turbulator - Immersion Tube.....	1
10	WS-028-22	Washer.....	4
11	SC-041-31	Cap Screw 3/8-16 x 1-1/4 Hex Hd. (SST).....	4
12	SC-041-31	Cap Screw 3/8-16 x 1-1/4 Hex Hd. (SST).....	4
13	WS-028-22	Washer.....	4
14	00-893891	Gasket - Immersion tube.....	1
15	00-893897	Burner - Infrared.....	1
16	00-748571-00002	Ignitor (With Terminals).....	1
17	WL-006-02	Lockwasher #8 Helical (SST).....	1
18	SC-021-13	Mach. Screw 8-32 x 1/4 Slotted Rd. Hd.....	1
19	00-748572	Electrode Assy.....	1
20	WL-006-02	Lockwasher #8 Helical (SST).....	1
21	SC-021-13	Mach. Screw 8-32 x 1/4 Slotted Rd. Hd.....	1
22	NS-031-21	Stop Nut 1/4-20 Hex (SST).....	4
23	WL-014-10	Lockwasher 1/4 External Shakeproof.....	4
24	00-893039-00012	Nut 3/8-16 Hex (SST).....	4
25	WL-006-28	Lockwasher 3/8 Helical.....	4
26	WS-028-22	Washer.....	4
27	00-918034	Seal - Blower/Burner.....	1
28	00-893893-00001	Plate - Reducer (NAT).....	1
29	00-948534	Kit - Gas Conversion (Natural to LP).....	1
30	NS-031-50	Stop Nut 6-32 Hex (SST).....	2
31	00-271123	Protector - High Limit.....	1
32	SC-021-08	Mach. Screw 6-32 x 3/8 Slotted Rd. Hd. (SST).....	2
33	SC-041-05	Cap Screw 1/4-20 x 5/8 Hex Hd. (SST).....	4
34	00-918034	Seal - Blower/Burner.....	1
35	00-893898	Blower - Gas.....	1
36	NS-031-21	Stop Nut 1/4-20 Hex (SST).....	2
37	00-918116-00001	Switch - Air.....	1
38	SD-038-02	Self-Tapping Screw 6-20 x 5/8 Phil. Pan Hd., Type B.....	2
39	00-748512	Board - Ignitor (24 VAC).....	1
40	SC-041-10	Cap Screw 5/16-18 x 5/8 Hex Hd. (SST).....	2
41	00-893895	Bracket - Ignitor Board.....	1
42	NS-015-11	Nut 5/16-18 Hex (SST).....	2
43	00-893887	Baffle - Exhaust.....	3
44	00-918178	Flange - Exhaust Mounting.....	1

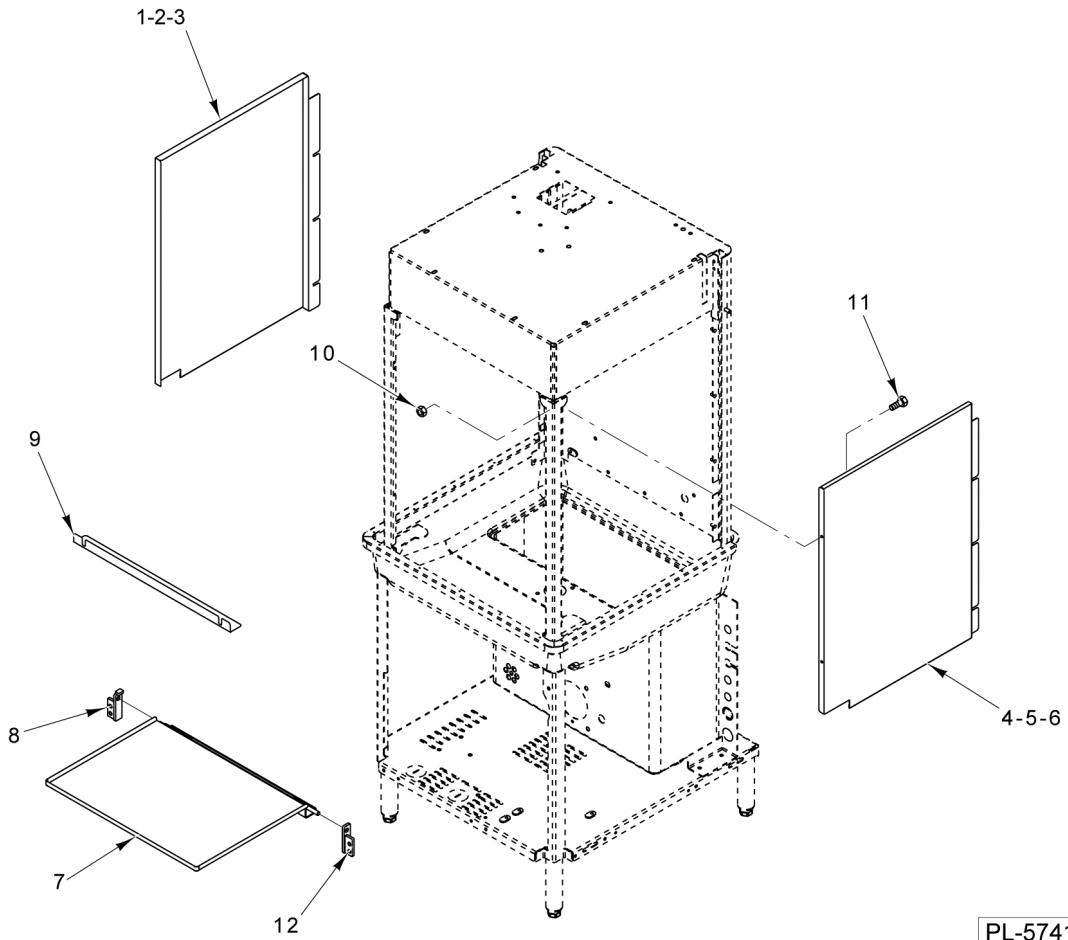

PL-57410

FRONT TRAY

FRONT TRAY

ILLUS.	PART NO.	NAME OF PART	AMT.
PL-57410			
1	00-936235	Panel - Splash (LH) (AM15VLF).....	1
2	00-893096	Panel - Splash (AM15F).....	1
3	00-950415	Panel - Splash (LH) (Standard).....	1
4	00-936234	Panel - Splash (RH) (AM15VLF).....	1
5	00-893096	Panel - Splash (AM15F).....	1
6	00-950414	Panel - Splash (RH) (Standard).....	1
7	00-893815	Tray Weldment.....	1
8	00-893816	Hinge Assy. (LH).....	1
9	00-893983	Baffle - Steam.....	1
10	NS-047-82	Stop Nut 1/4-20 Hex (SST).....	8
11	SC-059-29	Cap Screw 1/4-20 x 1/2 Hex Socket Hd. (SST).....	4
12	00-893817	Hinge Assy. (RH).....	1

- 3 00-295288 Peg Type Tray Rack (Packaged)
- 4 00-892671 Rack - Bun Pan
- 5 00-474800 Rack (6 Pan)

PARTS NOT ILLUSTRATED

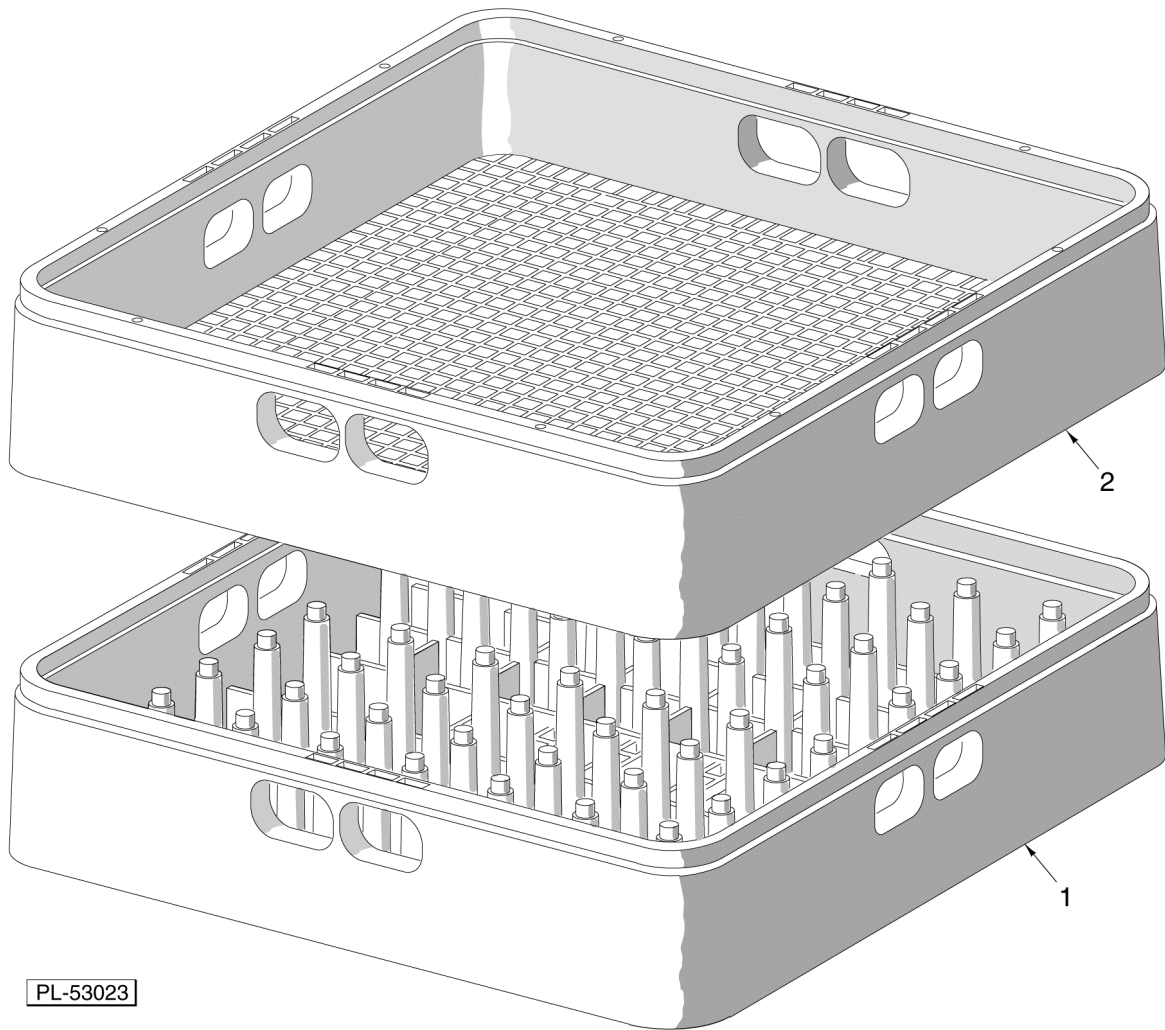

DISH RACKS

DISH RACKS

ILLUS.	PART NO.	NAME OF PART	AMT.
PL-53023			
1	00-315191	Rack - Peg (Packaged).....	1
2	00-315193	Rack - Combination (Packaged).....	1
3	00-295288	Peg Type Tray Rack (Packaged).....	1
4	00-892671	Rack - Bun Pan.....	1
5	00-474800	Rack (6 Pan).....	1

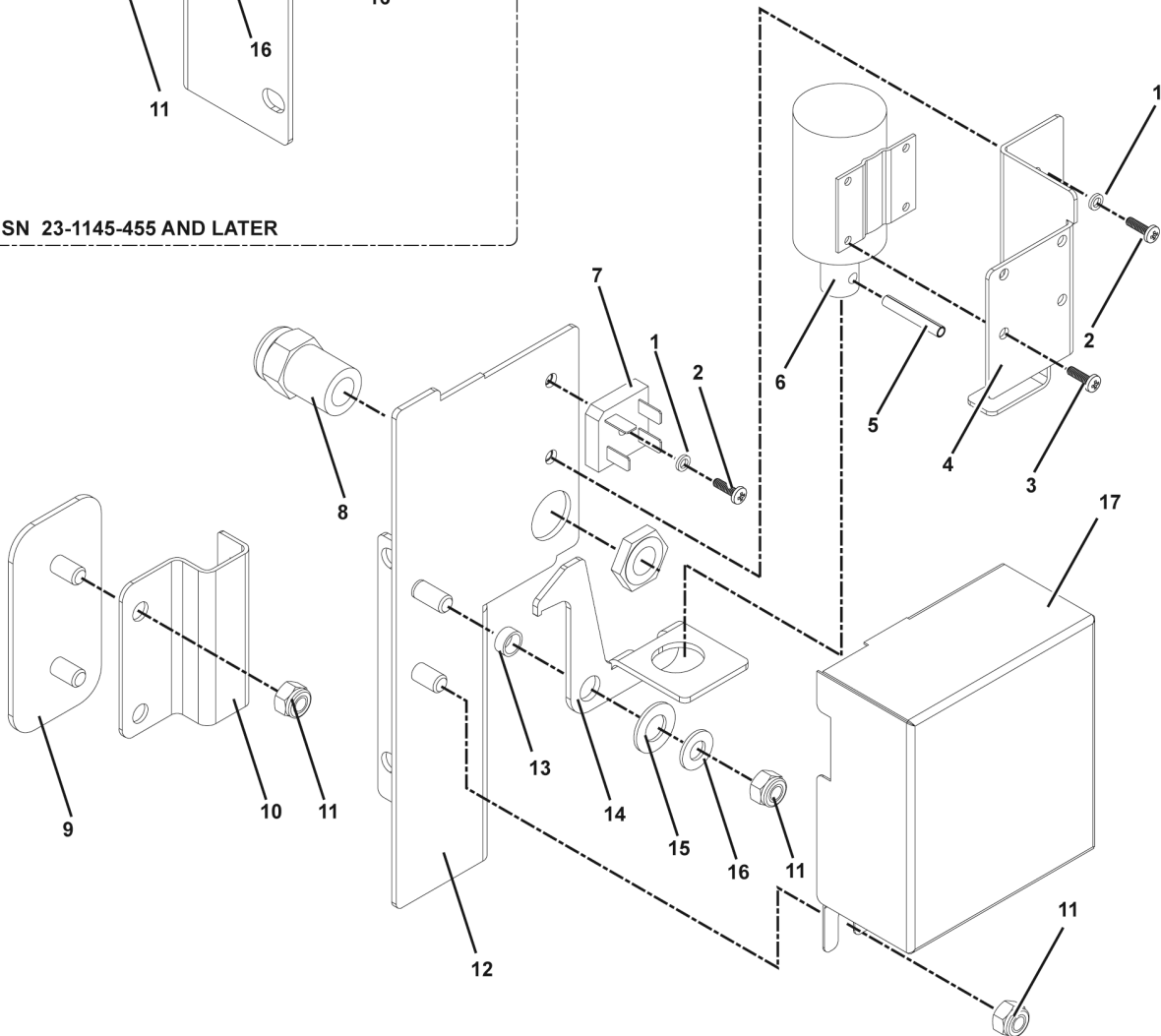
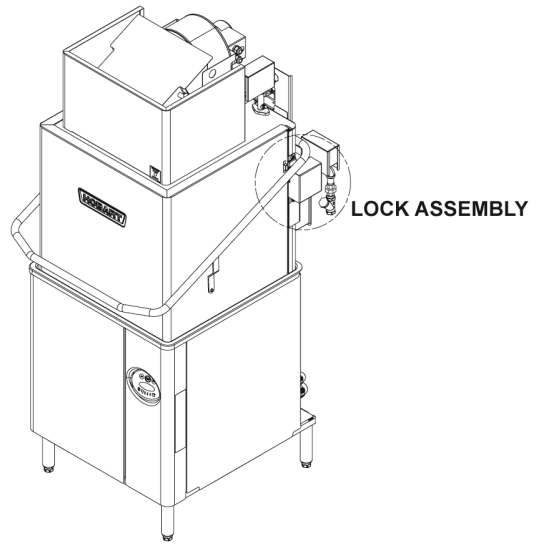
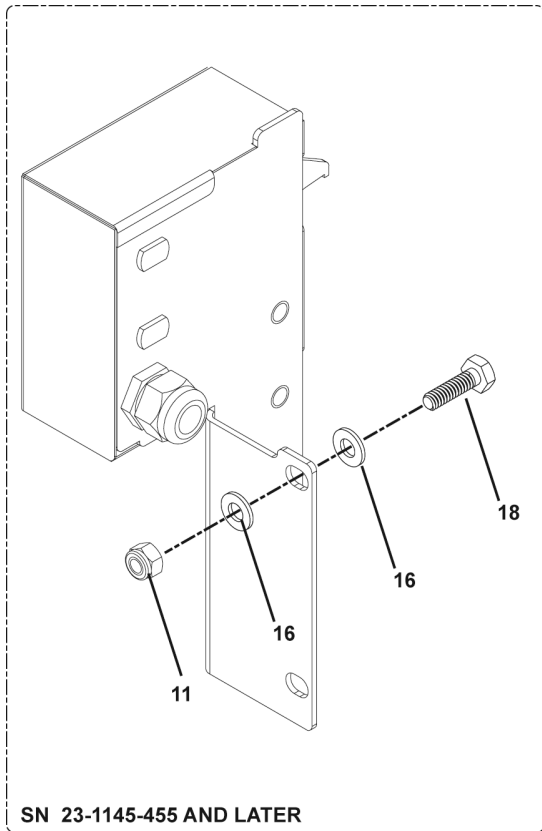

DOOR LOCK (AM15VL)

DOOR LOCK (AM15VL)

ILLUS.	PART NO.	NAME OF PART	AMT.
PL-AI4140			
1	WL-006-07	Lockwasher #10 Helical (SST).....	2
2	SC-080-12	Mach. Screw 10-24 x 5/8 Phil. Fil. Hd. (SST).....	2
3	SD-008-18	Self-Tapping Screw 8-18 x 3/8 Phil. Bndg. Hd., Type B.....	4
4	00-941245	Y, Bracket, Solenoid.....	1
5	RP-006-49	Pin, Roll .188 x 1.250.....	1
6	00-941290	Y, Solenoid, 125VDC.....	1
7	00-473660	Rectifier.....	1
8	FE-022-84	Connector - Strain Relief.....	1
9	00-941247	Y, Plate, Mount, Receiver.....	1
10	00-941244	Y, Receiver, Door.....	1
11	NS-036-19	Stop Nut 5/16-18 Hex (SST).....	6
12	00-941243	Y, Plate, Solenoid.....	1
13	00-893014-00002	Spacer - Door Link (Lower).....	1
14	00-941242	Y, Lock.....	1
15	WS-021-01	Washer.....	1
16	WS-005-32	Washer (SST).....	1
17	00-941248	Y, Cover, Receiver, Door.....	1
18	SC-041-11	Cap Screw 5/16-18 x 3/4 Hex Hd. (SST).....	2

Item Number	Description
1	Cable
2	Transformer
3	Fuse
4	Lead Wire Assembly
5	Lead Wire Assembly
6	Lead Wire Assembly
7	Lead Wire Assembly
8	Connector, Wire Terminal Block – 3 Connector
9	Connector, Wire Terminal Block – 2 Connector
10	Warning Label - Fuse

AI4041

DOOR LOCK - ELECTRICAL (AM15VL)

DOOR LOCK - ELECTRICAL (AM15VL)

ILLUS.	PART NO.	NAME OF PART	AMT.
PL-AI4141			
1	00-941295	Y, Cable Assembly, Door Lock.....	1
2	00-294500-046-1	Transformer (150 VA, 50/60 Hz.).....	1
3	FE-022-29	Fuse (250 V.) (1 Amp.).....	1
4	00-941296-00001	Assembly, Lead Wire.....	1
5	00-941296-00002	Assembly, Lead Wire.....	1
6	00-941296-00003	Assembly, Lead Wire.....	1
7	00-941296-00004	Assembly, Lead Wire.....	1
8	00-557975	Connector - Wire Terminal Block (3 Circuit).....	3
9	00-557976	Connector - Wire Terminal Block (2 Circuit).....	1
10	0F-941275	Warning Label, Fuse.....	1

