

# INSTRUCTIONS

## MODEL AM14F, AM14T, & AM14TC DISHWASHERS

### MODELS

AM14F	ML-110437
AM14T	ML-110412
AM14TC	ML-110414



701 S. RIDGE AVENUE  
TROY, OHIO 45374-0001

937 332-3000

[www.hobartcorp.com](http://www.hobartcorp.com)

FORM 34124 Rev. C (May 2000)

**POST IN A PROMINENT LOCATION THE INSTRUCTIONS TO BE FOLLOWED IN THE EVENT THE SMELL OF GAS IS DETECTED. THIS INFORMATION CAN BE OBTAINED FROM THE LOCAL GAS SUPPLIER.**

**IMPORTANT**

**IN THE EVENT A GAS ODOR IS DETECTED, SHUT DOWN UNIT(S) AT MAIN SHUTOFF VALVE AND CONTACT THE LOCAL GAS COMPANY OR GAS SUPPLIER FOR SERVICE.**

**FOR YOUR SAFETY**

**DO NOT STORE OR USE GASOLINE OR OTHER FLAMMABLE VAPORS OR LIQUIDS IN THE VICINITY OF THIS OR ANY OTHER APPLIANCE.**

# TABLE OF CONTENTS

GENERAL .....	4
INSTALLATION .....	5
UNPACKING .....	5
INSTALLATION CODES .....	5
LOCATION .....	6
WATER REQUIREMENTS .....	6
PLUMBING CONNECTIONS .....	7
DRAIN CONNECTION .....	7
WATER CONNECTION .....	7
GAS TANK HEAT .....	8
VENTING REQUIREMENTS — WITH GAS TANK HEAT .....	9
RATE OF EXHAUST FLOW CALCULATIONS .....	10
STEAM HEAT .....	11
ELECTRICAL CONNECTIONS — DISHWASHER .....	11
CHECK ROTATION .....	11
ELECTRICAL CONNECTIONS — OPTIONAL EQUIPMENT .....	12
ELECTRIC BOOSTER WATER HEATER — POWER SUPPLY CONNECTION .....	12
OPTIONAL EQUIPMENT CONTROL CONNECTIONS .....	12
Detergent Dispenser .....	12
Rinse Aid Dispenser .....	12
Vent Fan Control .....	12
Hobart Infrared Booster Gas Water Heater .....	12
ELECTRICAL DATA .....	13
OPERATION .....	14
PREPARATION .....	14
FILLING THE WASH TANK .....	14
DISHWASHING .....	15
BOOSTER HEATER .....	16
CLEANING .....	16
DOs AND DON'Ts FOR YOUR NEW HOBART WAREWASHER.. .....	17
MAINTENANCE .....	18
WASH ARMS .....	18
MOTOR(S) .....	18
GAS FLUE .....	18
TROUBLESHOOTING .....	18
MANUAL RESET BUTTON ON PUMP MOTORS .....	18
SERVICE .....	20

# Installation, Operation, and Care of MODEL AM14F, AM14T, AM14TC DISHWASHERS

## SAVE THESE INSTRUCTIONS

### GENERAL

The AM14T, AM14TC, and AM14F dishwashers are semi-automatic rack-type machines. On model AM14T (Fig. 1) the doors open on opposite sides of the machine allowing the rack to move straight through. Model AM14TC can be located in a corner; adjacent doors open so the rack moves in and out at a 90° angle. Model AM14F (Fig. 1) uses its pull-down front door for loading or unloading a rack of dishes or utensils.

The AM14T, AM14TC, and AM14F dishwashers are designed to operate in one of two modes: Hot water sanitizing mode (designated by the letter "H" at the end of the machine serial number), or a chemical sanitizing mode (designated by the letter "L" at the end of the machine serial number). The serial number can be found on the machine data plate.

**Model AM14T**

**Model AM14F**

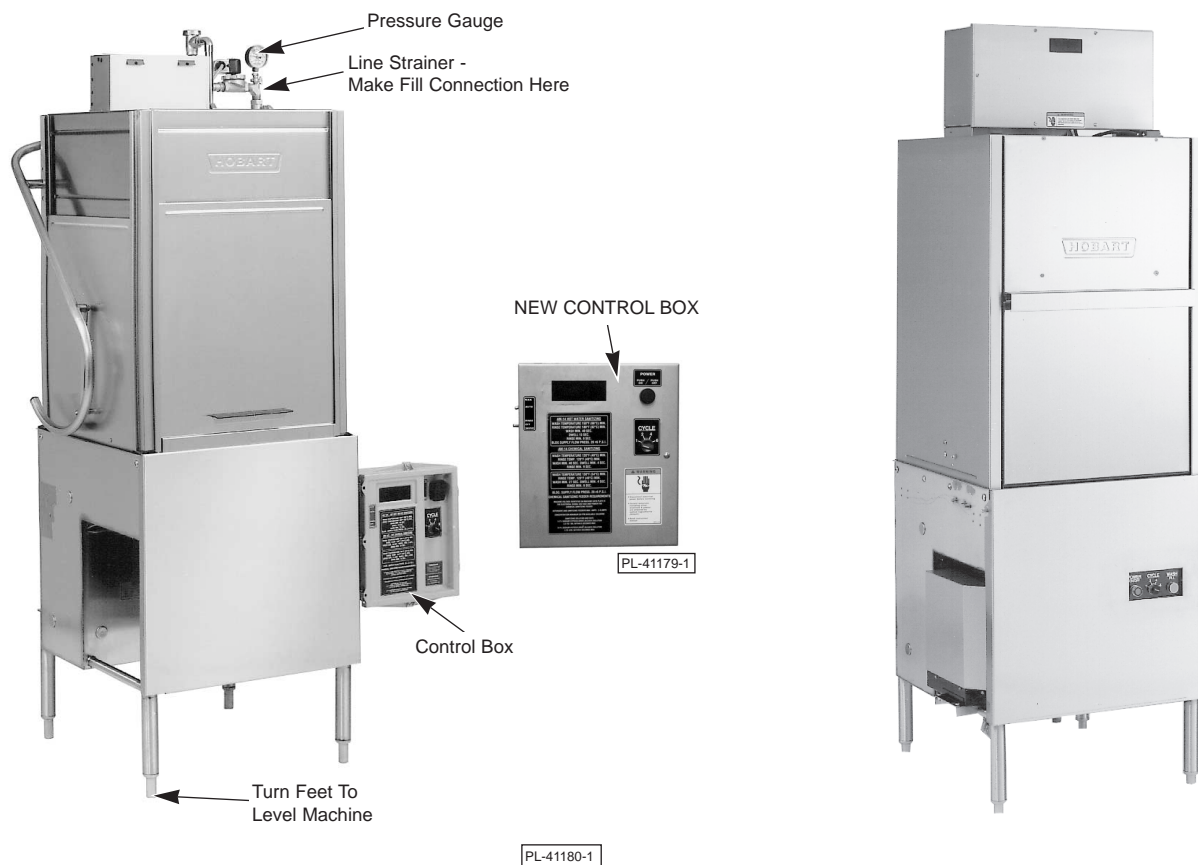

**Fig. 1**

DO NOT attempt to operate this dishwasher in the chemical sanitizing mode without a properly installed, NSF-listed, chemical sanitizer feeder (not supplied with machine). Contact an authorized detergent representative for information about a chemical sanitizer feeder.

The pump motor is rated 2HP and has thermal overload protection.

The fill line incorporates an atmospheric vacuum breaker to prevent any reverse flow of water from the dishwasher into the potable water supply.

A float, located in the wash tank, will shut off the heat supply if the water level becomes too low. When the water returns to a proper level, the heating circuit is again operational.

Available as an optional accessory is a frame-mounted 10KW electric booster water heater to maintain a minimum final rinse temperature of 180°F.

Also available as an optional accessory is the model IB57 Infrared Booster Gas Water Heater.

## **INSTALLATION**

### **UNPACKING**

Immediately after unpacking the dishwasher, check for possible shipping damage. If this machine is found to be damaged, save the packaging material and contact the carrier within 15 days of delivery.

Prior to installation, test the electrical service to make sure it agrees with the specifications on the machine data plate (and booster data plate if applicable). Data plate for AM14T and AM14TC is located on the side of the control box. For AM14F, the data plate is located on the control box mounting bracket. A separate data plate for the electric booster is located on the back side of the booster (when equipped).

### **INSTALLATION CODES**

Installation must be in accordance with state and local codes, or in the absence of local codes, with the National Fuel Gas Code, ANSI Z223.1 (latest edition) if applicable, and the National Electrical Code, ANSI/NFPA 70 (latest edition). In Canada, the installation standards are: CAN/CGA B149.1, CAN/CGA B149.2, and CSA C22.2 No.1 (latest editions).

## LOCATION

Place the dishwasher in its operating location. Before finalizing the location, make sure that consideration has been given for the electrical conduit, water supply, drain connection, steam or gas supply (if applicable), tabling (if needed), chemical feeder replenishment (if applicable), and adequate clearance for opening the doors.

On models AM14T and AM14TC, the control box (Fig. 1) is mounted  $4\frac{5}{8}$ " below the dish table when shipped from the factory. It can be changed to  $12\frac{5}{8}$ " or  $31\frac{1}{8}$ " below the dish table by removing the two mounting bolts and reinstalling them in the holes provided.

The dishwasher must be level before any connections are made. Turn the threaded feet (Fig. 1) as required to level the machine and adjust to the desired height.

On models AM14T and AM14TC, dish tables should be turned down and fitted into the dishwasher (Fig. 2). Use an NSF approved sealer between table and tank lip to prevent leakage. Fasten the tables to the tank lip with truss head screws. Dish tables are not required with model AM14F.

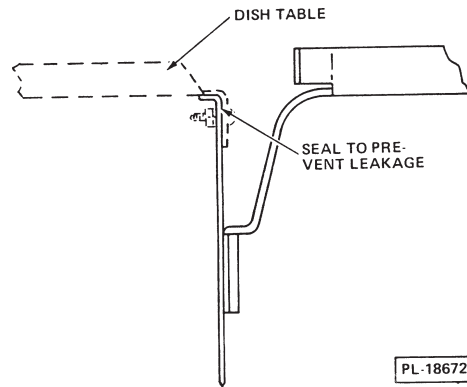

Fig. 2

High-temperature or gas heat dishwashers will probably require a hood or vent over the dishwasher in order to meet local codes. Low-temperature chemical sanitizing machines or low usage electric or steam heat dishwashers may not require individual venting of the machine if the room is amply exhausted. Refer to pages 8 and 9 for venting and hood requirements.

## WATER REQUIREMENTS

Proper water quality can improve ware washing performance by reducing spotting, lowering chemical supply costs, enhancing effectiveness of labor, and extending equipment life. Local water conditions vary from one location to another. The recommended proper water treatment for effective and efficient use of this equipment will also vary depending on the local water conditions. Ask your municipal water supplier for details about local water specifics prior to installation.

Recommended water hardness is 4 – 6 grains of hardness per gallon. Chlorides must not exceed 50 parts per million. Water hardness above 6 grains per gallon should be treated by a water conditioner (water softener or in-line treatment). Water hardness below 4 grains per gallon also requires water treatment to reduce potential corrosion. Water treatment has been shown to reduce costs associated with machine cleaning, reduce deliming of the dishwasher, reduce detergent usage, and reduce corrosion of metallic surfaces in the booster water heater and dishwasher.

Sediment, silica, chlorides, or other dissolved solids may lead to a recommendation for particulate filtration or reverse osmosis treatment.

If an inspection of the dishwasher or booster heater reveals lime build-up after the equipment has been in service, in-line water treatment should be considered, and, if recommended, should be installed and used as directed. Contact your Hobart Service office for specific recommendations.

## PLUMBING CONNECTIONS

**WARNING:** PLUMBING CONNECTIONS MUST COMPLY WITH APPLICABLE SANITARY, SAFETY, AND PLUMBING CODES.

### DRAIN CONNECTION

The drain connection is made using 2" pipe.

If a right hand drain is desired, it can be changed from the standard left-hand by removing the pipe plug from the drain valve and reinstalling it in the opposite end of the drain valve.

If a grease trap is required by code, it should have a minimum flow capacity of 42 gallons per minute.

### WATER CONNECTION

A suitable water hammer arrestor should be installed in the water line just ahead of the dishwasher.

#### Without Electric or Gas Booster Water Heater

The water supply line is connected to the line strainer (Fig. 1) with 3/4" pipe.

Minimum water temperatures are listed below:

Sanitizing Mode	Wash	Rinse
Hot Water	150°F (66°C)	180°F (82°C)
Chemical (Normal Duty)	120°F (49°C)*	120°F (49°C)*
Chemical (Light Duty)	130°F (54°C)*	120°F (49°C)*

\* Temperatures shown are minimum; recommended temperature is 140°F (60°C).

Proper dishwasher operation requires a flowing pressure of 20 ± 5 psig at the dishwasher. If the flowing pressure exceeds 25 psig, a pressure reducing valve (not supplied) must be installed in the water supply line.

A pressure gauge (Fig. 1) is provided for verification of proper water pressure. Present models monitor the water pressure when the solenoid valve is open and water is flowing. On earlier models where the pressure gauge was connected into a petcock, the petcock MUST always remain closed except when making an instantaneous check of flowing pressure.

#### With Electric Booster Water Heater

The water supply line is connected to the booster (Fig. 6) with 3/4" pipe.

The water supply should have a minimum temperature of 120°F – 140°F and a flowing pressure of 15 – 25 psig at the pressure gauge tee beside the solenoid valve. If the flowing pressure exceeds 25 psig, a pressure reducing valve (not supplied) must be installed in the water supply line.

Incoming water temperature below 120°F may require the wash cycle time to be extended from 40 to 60 seconds. To have the cycle time adjusted, contact your local authorized Hobart Service Office.

Pressure / temperature relief valve piping must be extended to an open drain receiver in the floor. Refer to the tag attached to the pressure / temperature relief valve drain piping for additional installation instructions.

## GAS TANK HEAT (When Specified)

Check the gas data plate attached to the dishwasher or the tag attached to the incoming gas piping for the type of gas to be used. Connect the gas supply to the 1/2" NPT gas inlet at the manual gas valve. The burner is not adjustable. The maximum flowing inlet gas pressure must not exceed the Maximum value in the table. If line pressure exceeds the Maximum value in the table, an additional regulator valve (not supplied) must be installed in the supply line.

## GAS PRESSURE SPECIFICATION [ FLOWING GAS PRESSURE — NOT STATIC ]

Model	Type of Gas	BTU/HR	Inches W.C. (Water Column)		
			Incoming Line Pressure		Manifold Pressure
			Minimum	Maximum	
AM14F AM14T	Natural	20,000	4.5	10.5	3.2
AM14TC	Propane	20,000	9.0	13.0	9.0

Static inlet gas pressure should not exceed 14" W.C. for either natural or propane gas. The minimum value is for purpose of input adjustment.

The gas valve (Fig. 3) is provided with a pressure tap to measure the gas pressure downstream, which is also the manifold pressure. Gas supply piping must have a sediment trap (supplied by others) installed ahead of the dishwasher's gas control (Fig. 3).

**NOTE: DO NOT** use Teflon tape on gas line pipe threads. For gas line pipe connections, use LOCTITE 565, Hobart part 546292 or a flexible sealant suitable for use with Natural and Propane Gases.

The appliance and its gas connections must be leak tested before placing the appliance in operation. Use soapy water for leak test. **DO NOT** use open flame. The installation must conform with local codes, or in the absence of local codes, with the National Fuel Gas Code, ANSI Z223.1 (latest edition). Copies may be obtained from American Gas Association, Inc., 1515 Wilson Blvd., Arlington, VA 22209.

The appliance and its individual shutoff valve must be disconnected from the gas supply piping system during any pressure testing of that system at test pressures in excess of 1/2 psig (3.45kPa).

The appliance must be isolated from the gas supply piping system by closing its individual manual shutoff valve during any pressure testing of the gas supply piping system at test pressures equal to or less than 1/2 psig (3.45kPa).

Dissipate test pressure from the gas supply line before re-connecting the appliance and its manual shutoff valve to the gas supply line. **Caution: Failure to follow this procedure may damage the gas valve.**

The dishwasher must be installed so that the flow of combustion and ventilation air will not be obstructed. Adequate clearances for air openings into the combustion chamber must be provided. Make sure there is an adequate supply of make-up air in the room to allow for combustion of the gas at the burner(s).

Keep the appliance area free and clear from all combustible substances. Do not obstruct the flow of combustion and ventilation air. The dishwasher must have a minimum clearance from combustible construction of 1 inch from the flue at the rear and 0 inches at the sides. A clearance of 40 inches must be provided at the front of the dishwasher for servicing and proper operation.

The burner is ignited automatically by solid state electronic circuitry; there is no pilot light. Gas flow is regulated by the temperature control circuit.

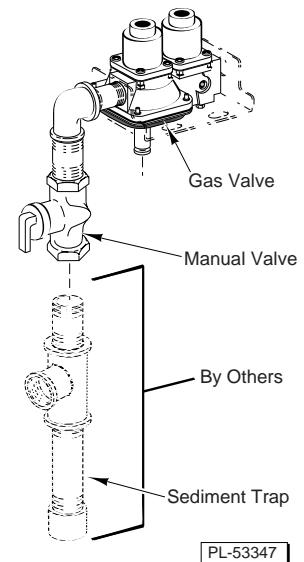

**Fig. 3**

## VENTING REQUIREMENTS — WITH GAS TANK HEAT

The Hobart AM14F / AM14T / AM14TC dishwasher equipped for gas tank heat is not provided with a flue collar and is not intended to have the flue directly connected to a ventilation system. However, the products of combustion must be vented to the outside air. The most common method of venting is a vent hood over the entire dishwasher (Fig. 4). Refer to Rate of Exhaust Flow Calculations on the next page for calculations of the proper vent rate for your hood. Another method is a small vent hood (Fig. 5) positioned about five inches above the flue exit at the rear of the dishwasher and connected to existing ductwork. In either case, an electrical interlock must be provided to allow the flow of gas to the dishwasher burner ONLY when the exhaust system is energized. For additional information, refer to the National Fuel Gas Code, ANSI Z223.1, NFPA 54.

- **IMPORTANT:** Make sure the installation meets the local code for your area.

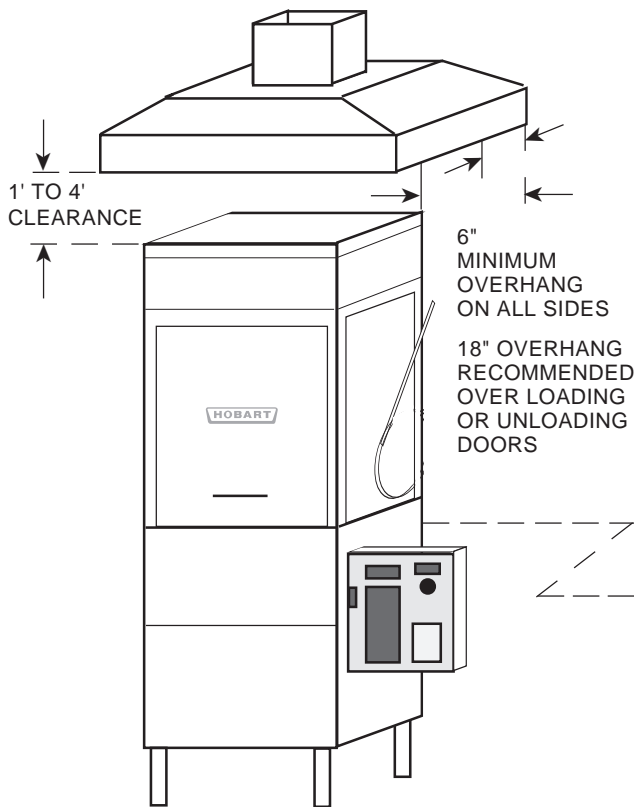

Fig. 4

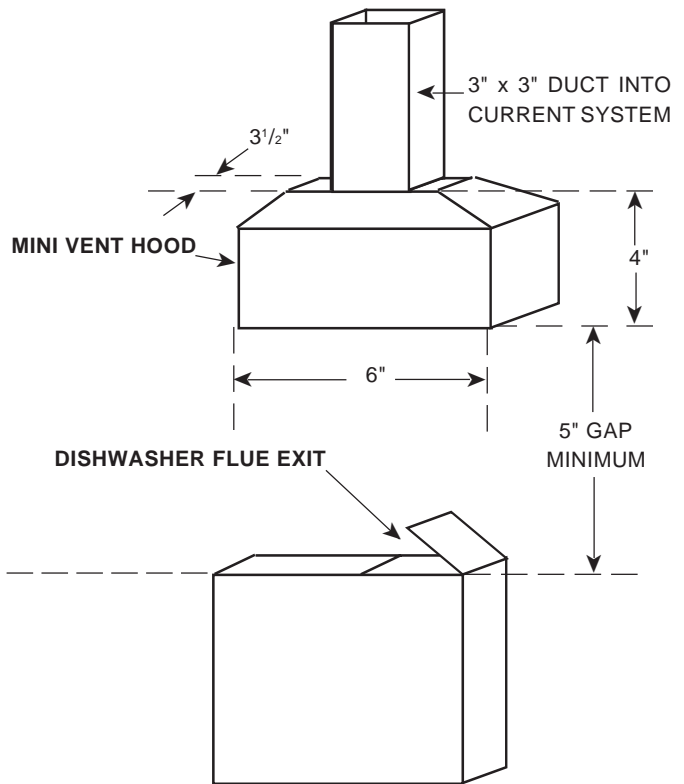
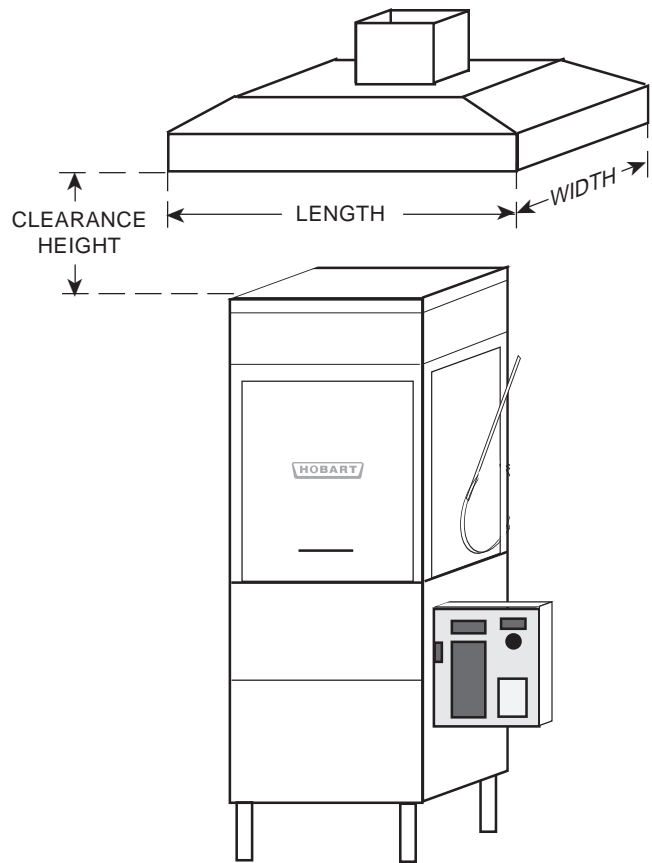

Fig. 5

**NOTE:** Any listed and labeled factory-built commercial exhaust hood tested in accordance with UL Standard 710 by a nationally recognized testing laboratory, should be installed according to the terms of its listing and the manufacturer's installation instructions.



**RATE OF EXHAUST FLOW CALCULATIONS**

Based on the 1996 International Mechanical Code.

The **Rate** of air flow required for a vent hood is calculated using the following definitions:

Q = Rate of Air Flow in Cubic Feet Per Minute or [ CFM ] Required for the Hood.

A = Area of Hood Opening = (L x W) in Feet<sup>2</sup>

D = Clearance Height = Distance in Feet from lower lip of hood to top of dishwasher chamber.

P = Perimeter of Hood that is Open. This depends on the hood design, as follows:

**Perimeter Calculation Formula**

Hood Design	Corner	Wall	Island
<b>Number of Open Sides</b>	2 Sides Open	3 Sides Open	4 Sides Open
<b>P =</b>	L + W	L + W + W	L + L + W + W
<b>Dimensions</b>	Feet	Feet	Feet

If there are four open sides (Island Design), the calculation of the Rate is as follows:

$$Q = 75 \times A$$

If there are three or fewer open sides, the calculation of the Rate is as follows:

$$Q = 50 \times A$$

As an alternate method, the Rate can be calculated as follows:

$$Q = 50 \times P \times D$$

Example:

$$L = 3 \quad W = 3 \quad D = 2$$

**Rate Calculations**

Hood Design	Corner	Wall	Island
<b>Number of Open Sides</b>	2 Sides Open	3 Sides Open	4 Sides Open
<b>Q = 75 x A</b>			675 CFM
<b>Q = 50 x A</b>	450 CFM	450 CFM	
<b>Q = 50 x P x D</b>	600 CFM	900 CFM	1200 CFM

## **STEAM HEAT (When Specified)**

A  $\frac{3}{4}$ " union connection for the steam supply line is located on the bottom right side of the dishwasher. The steam supply must have a flowing pressure of 15 – 20 psig.

Steam flow is controlled by a solenoid valve, as well as a mechanical ball valve. The ball valve should be closed when the dishwasher is not in use.

## **ELECTRICAL CONNECTIONS — DISHWASHER**

**WARNING:** ELECTRICAL AND GROUNDING CONNECTIONS MUST COMPLY WITH THE APPLICABLE PORTIONS OF THE NATIONAL ELECTRICAL CODE AND/OR OTHER LOCAL ELECTRICAL CODES.

**WARNING:** DISCONNECT ELECTRICAL POWER SUPPLY AND PLACE A TAG AT THE DISCONNECT SWITCH TO INDICATE THAT YOU ARE WORKING ON THE CIRCUIT.

**NOTE:** When a booster is supplied, the dishwasher electrical connection is separate from the booster electrical connection.

Refer to the wiring diagram attached inside the control box and to the machine data plate for service size requirements when connecting the dishwasher. **NOTE:** On models AM14T and AM14TC, the  $\frac{7}{8}$ " plugged holes in the side of the control box are for detergent and chloritizer / rinse feeder connections only. If detergent and chloritizer / rinse feeder electrical connections are required, remove the plug button(s) and connect through the hole(s) provided. There is no provision for automatically controlling any other external devices. The  $1\frac{3}{4}$ " hole in the right-hand bottom of the control box is for making the dishwasher electrical service connections. On model AM14F, the holes for the chloritizer / rinse feeder electrical connections and the electrical service connections are at the rear of the control box which is located on top of the machine.

A fused disconnect switch or circuit breaker (not supplied) must be installed in the electrical service line supplying this dishwasher and should meet the requirements of your local electrical code.

All connections are made at the terminal block in the control box. Connect a permanent electrical power supply to the incoming power supply block, and connect a ground lead to the grounding lug in the control box if grounding is not provided by the conduit used.

## **CHECK ROTATION (Three-Phase Machines Only)**

Three-phase motors must rotate in the direction of the arrow on the pump housing. In order to check rotation, the motor fan cover must be removed. Close the machine doors and press the power switch to ON. When the machine is completely filled, place the MANUAL/AUTO switch (located on the side of the control box) on MANUAL and place the WASH / RINSE switch (located under the MANUAL/AUTO switch) on WASH. The motor fan must rotate in the direction of the arrow on the pump housing.

If the rotation is incorrect, **DISCONNECT ELECTRICAL POWER SUPPLY** and interchange any two of the incoming power supply leads. Reconnect the power supply and verify correct rotation. Replace the motor fan cover.

## ELECTRICAL CONNECTIONS — OPTIONAL EQUIPMENT

**WARNING:** ELECTRICAL AND GROUNDING CONNECTIONS MUST COMPLY WITH THE APPLICABLE PORTIONS OF THE NATIONAL ELECTRICAL CODE AND/OR OTHER LOCAL ELECTRICAL CODES.

**WARNING:** DISCONNECT ELECTRICAL POWER SUPPLY AND PLACE A TAG AT THE DISCONNECT SWITCH TO INDICATE THAT YOU ARE WORKING ON THE CIRCUIT.

### ELECTRIC BOOSTER WATER HEATER — Power Supply Connection

**NOTE:** Electric Booster electrical connection must be separate from the dishwasher electrical connection.

Before making electrical connection, test the electrical service to assure that it agrees with the specifications on the Electric Booster data plate (Fig. 3). Also, refer to the wiring diagram attached inside the cover of the Electric Booster.

A fused disconnect switch or circuit breaker (not supplied) must be installed in the electrical service line supplying this booster and should meet the requirements of your local electrical code.

Booster electrical connections are made to the contactor in the booster. If grounding is not provided by the conduit used, connect the ground lead to the grounding lug provided (Fig. 6).

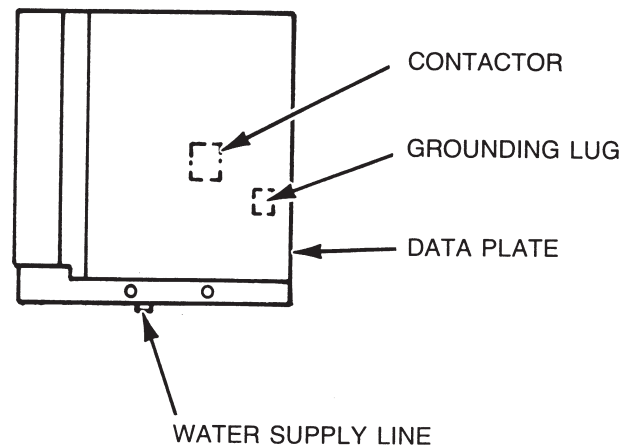

PL-21129-1

Fig. 6

## OPTIONAL EQUIPMENT CONTROL CONNECTIONS

### Detergent Dispenser

Maximum rating for detergent dispenser connected to DPS1 and DPS2 is 1.5 Amps at line voltage.

### Rinse Aid Dispenser

Maximum rating for rinse aid dispenser connected to RPS1 and RPS2 is 1.5 Amps at line voltage.

### Vent Fan Control

The maximum rating for a vent fan control relay connected to terminals 4 and 6 is either 30 Amps at 120 Volts (1.5 HP) or 25 Amps at 277 Volts (3.0 HP). The vent fan control relay provides switch contacts only and does not provide the power supply for the vent fan motor. When the dishwasher is connected to the vent fan, the vent fan is switched on when the dishwasher is on, and off when the dishwasher is off.

### Hobart Infrared Booster Gas Water Heater

The maximum rating for connecting a Hobart Model IB57 Dishwasher Activated infrared gas booster water heater to BSTR1 and BSTR2 is 0.5 Amp at 24 Volts. If a Stand Alone Booster Heater is used, no electrical connection to the dishwasher is allowed. Refer to the Infrared Booster Gas Water Heater Manual for additional installation details.

**ELECTRICAL DATA**

Model	Volts / Hz / Ph	Minimum Circuit Ampacity Maximum Protective Device AMPS		
		Tank Heat	Dishwasher	Electric Booster
AM14T AM14TC AM14F	120 / 60 / 1	Electric	80	
		Steam or Gas	35	
	208 - 240 / 60 / 1	Electric	50	
		Steam or Gas	20	
	208 / 60 / 1	Electric		60
		Steam or Gas		60
	240 / 60 / 1	Electric		60
		Steam or Gas		60
	208 - 240 / 60 / 3	Electric	30	
		Steam or Gas	15	
	208 / 60 / 3	Electric		40
		Steam or Gas		40
	240 / 60 / 3	Electric		40
		Steam or Gas		40
	480 / 60 / 3	Electric		20
		Steam or Gas		20

# OPERATION

## PREPARATION

Place the pump strainer (when equipped), overflow tube, overflow cover, end cover, slanted strainer, and the strainer bucket in their respective positions (Fig. 7).

An automatic detergent dispenser is recommended. Closely follow supplier's instructions. If no automatic dispenser is used, scatter the initial charge of detergent on the slanted strainer. Replenish as needed.

Open the manual steam (globe) valve or gas valve (if applicable). Close the door(s) which automatically closes the drain. On model AM14T, the front inspection door must be closed before the counterbalanced doors can be lowered.

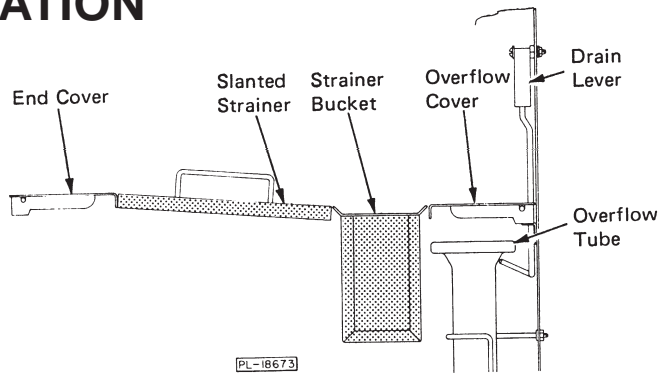

Fig. 7

## FILLING THE WASH TANK — Models AM14T / AM14TC (Fig. 8)

Push the POWER switch ON. Set the MANUAL / AUTO switch to AUTOMATIC and make sure the WASH / RINSE switch is OFF. If all machine doors are closed, the fill cycle will begin automatically. During the fill cycle, the word *FILL* is displayed on the readout / display.

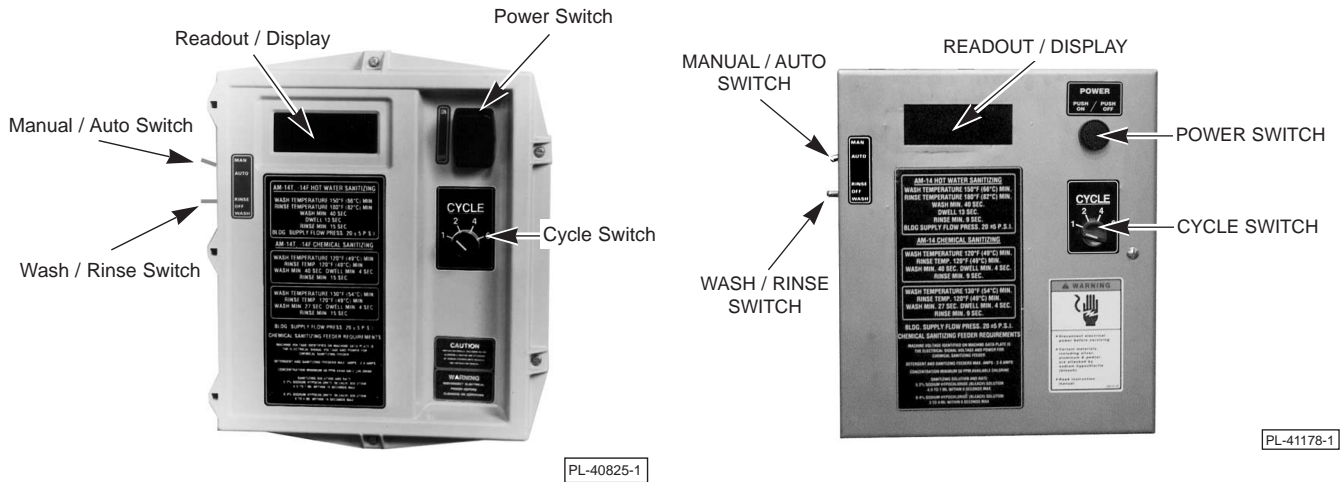

Fig. 8

## FILLING THE WASH TANK — Model AM14F (Fig. 9)

Push the POWER switch ON and push the WASH / FILL switch to fill the machine initially. During the fill cycle, the word *FILL* is displayed on the readout / display. On model AM14F, the readout / display is located on the control box on top of the dishwasher.

When the fill cycle has completed, the wash temperature is displayed on the readout / display. During a wash cycle, the tank water temperature, along with the word *WASH* will be displayed on the readout / display. During a rinse cycle, the rinse water temperature, along with the word *RINSE* will be displayed. When the rinse cycle is completed, the readout / display will display the tank water temperature.

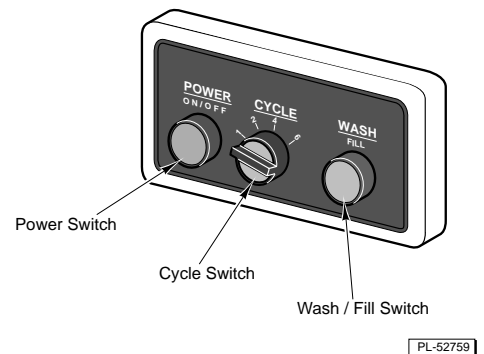

Fig. 9

## DISHWASHING

Scrape the dishes to remove large particles of food and debris. Never use steel wool on ware to be loaded into the dishwasher.

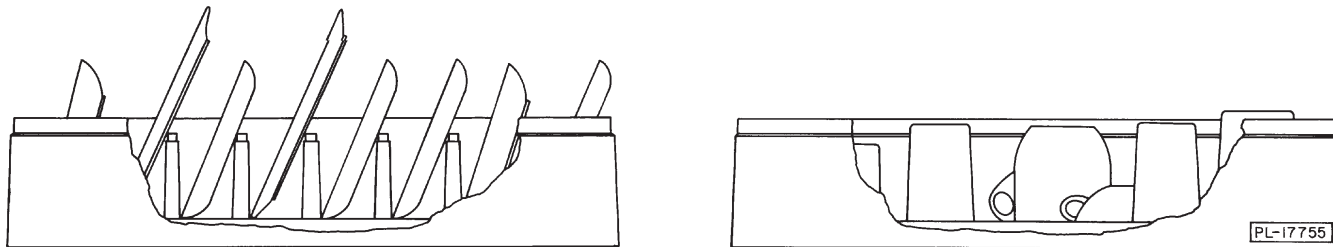

Fig. 10

Place the dishes in a rack so water has free access to all sides of every dish. Stand plates and dishes up edgewise in a peg-type rack (Fig. 10). Cups, glasses, and bowls should be inverted in an open-type or compartment type rack (Fig. 10). Silverware and other small pieces may be scattered loosely over the bottom of a flat-bottom rack.

On all models, select the wash cycle duration by turning the **CYCLE** switch to the desired setting.

### WASH CYCLE TIME SETTINGS

Cycle Switch Setting	1	2	4	6
Wash Cycle Duration (Seconds)	40	120	240	360

Wash cycles are followed by a 15 second rinse.

### Models AM14T / AM14TC

In Automatic mode, the **MANUAL / AUTO** switch (Fig. 8) is on **AUTOMATIC** and the **WASH / RINSE** switch is **OFF**. The wash and rinse cycles begin automatically. The wash cycle begins when the machine doors are closed. The rinse cycle begins when the wash cycle is completed.

In Manual mode, the **MANUAL / AUTO** switch (Fig. 8) is on **MANUAL**. The wash cycle begins when the **WASH / RINSE** switch is on **WASH**. After the desired wash time (minimum 40 seconds recommended), hold the **WASH / RINSE** switch in the **RINSE** position for the desired rinse time (minimum 18 seconds recommended).

### Model AM14F

After the initial fill, you must press the **WASH / FILL** switch (Fig. 9) to begin the wash cycle which is automatically followed by the rinse cycle.

After filling a rack, open the appropriate door(s), slide the rack into the dishwasher, and close the door(s). Start the wash and rinse cycles according to your model and mode.

When the wash and rinse cycles are finished, open the door(s), remove the clean dishes, slide in another rack, and close the door(s). Repeat.

If you want to add a dish after the wash cycle has started, turn off the power switch and wait 10 seconds to allow wash arm coastdown and avoid water splashing before opening the door(s).

## ELECTRIC BOOSTER WATER HEATER (When Equipped)

The rinse temperature may be adjusted on machines equipped with electric booster water heater by turning the adjustment screw (Fig. 11) clockwise to increase the temperature, or counterclockwise to decrease temperature. If proper rinse temperature cannot be maintained, push the red reset button (Fig. 11). If this does not correct the situation, contact Service.

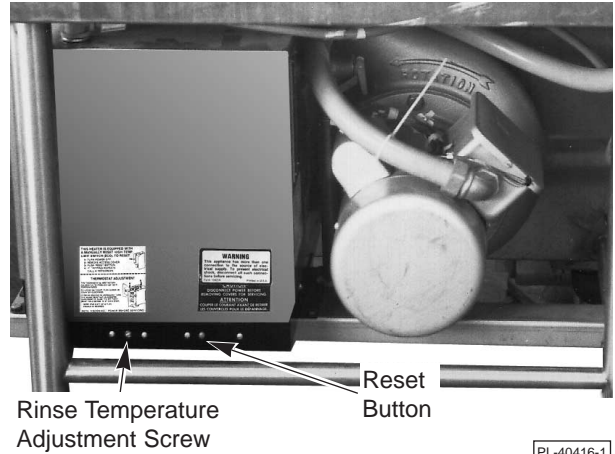

Fig. 11

## CLEANING

The machine must be thoroughly cleaned at the end of each working shift or at least daily. Never use steel wool to clean warewasher surfaces. Use only products formulated to be safe on stainless steel.

Turn off the power switch.

If the machine has steam heat, close the manually operated steam (ball) valve.

Open the machine door(s).

Clean off the dish tables into the dishwasher.

Drain the machine by pulling the drain lever (Fig. 4).

Remove and empty the slanted strainer and strainer bucket. Wash and rinse them thoroughly.

Raise the overflow cover and remove the overflow tube. Wash and rinse the overflow tube inside and out.

Remove the pump strainer (if equipped) and clean in a sink.

Thoroughly cleanse and flush the dishwasher interior. Remove remaining soil with a soft cloth or brush and mild cleanser. Rinse again. Do not allow food soil to accumulate on the tank bottom.

Replace all removed parts.



Fig. 12

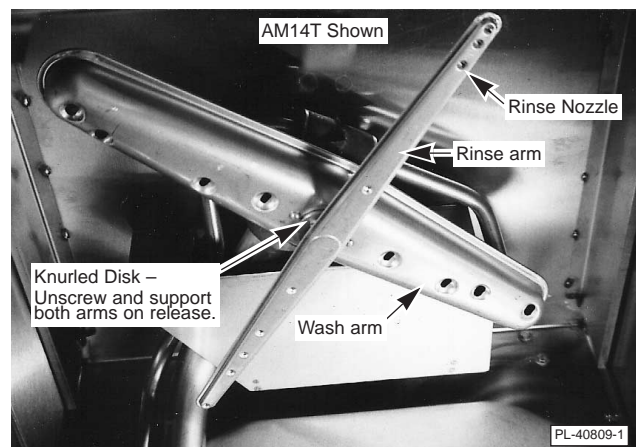

Fig. 13

## **CLEANING Con't.**

Leave the machine doors open to allow the interior to dry and air out.

Make sure that the wash and rinse arms rotate freely and are free of any obstructions.

Check rinse nozzles (Figs. 12, 13) to make sure they are free of any lime and solids.

## **DOs AND DON'Ts FOR YOUR NEW HOBART WAREWASHER**

**DO** assure proper water hardness (4 – 6 grains per gallon is recommended).

**DO** pre-scrub dishes thoroughly.

**DO** use only detergents recommended by your chemical professional.

**DO** at the end of the day, thoroughly cleanse the machine, rinse, and dry (leave doors open).

**DO** closely follow your chemical professional's prescribed deliming schedule.

**DO** use only products formulated to be safe on stainless steel.

**DO NOT** over soften water (recommended water hardness is no less than 4 grains per gallon).

**DO NOT** use detergents formulated for residential dishwashers.

**DO NOT** allow food soil to accumulate on the tank bottom.

**DO NOT** exceed chemical manufacturer's recommended concentrations for detergent, sanitizer, rinse aid, or lime scale remover.

**DO NOT** use steel wool to clean ware or warewasher surface.

**DO NOT** allow foreign objects to enter the unit, especially metallic contaminants.

**NOTE:** Failure to follow use, care, and maintenance instructions may void your Hobart warewasher warranty.

# MAINTENANCE

**WARNING:** DISCONNECT ELECTRICAL POWER SUPPLY (BOTH DISHWASHER AND BOOSTER IF APPLICABLE) AND PLACE A TAG(S) AT THE DISCONNECT SWITCH(ES) TO INDICATE THE CIRCUIT(S) ARE BEING WORKED ON BEFORE BEGINNING ANY MAINTENANCE PROCEDURE.

## WASH ARMS

Upper and lower wash and rinse arms (Figs. 12, 13) should turn freely and continue turning for a few seconds after being whirled by hand. To check, **DISCONNECT ELECTRICAL POWER SUPPLY (BOTH DISHWASHER AND BOOSTER IF APPLICABLE)**, rotate arms, and remove any obstructions causing improper operation.

If the slanted strainer or strainer bucket is not properly in place, obstructions (such as food particles or bones) may clog the wash arm nozzles. The wash arms are easily removed for cleaning.

### Removing Wash / Rinse Arms — AM14T / AM14TC / AM14F

To remove the lower wash and rinse arms, unscrew the knurled disk between the rinse and wash arms (Fig. 12) and lift off both the rinse and wash arms. It is not necessary to remove the spacer located on the lower wash arm shaft.

The upper rinse arm and wash arm are removed by unscrewing the knurled disk (Fig. 13) and lowering both arms together. Be careful not to drop these arms.

## MOTOR(S)

The wash pump motor and the blower motor used on gas heat machines are equipped with permanently lubricated bearings and require no lubrication maintenance.

## GAS FLUE

When cool, check the flue opening of this dishwasher every three months for obstructions.

# TROUBLESHOOTING

### Manual Reset Button on Pump Motors (When Equipped)

In case the pump becomes overheated, the thermal overload will cause the motor to not operate. Motors equipped with Automatic Reset will become operational after they cool down. Some motors are equipped with a gray manual reset button on the bottom of the motor near the endbell opposite of the motor junction box (Fig. 14). To restart motors equipped with reset button after the motor has cooled, press the gray manual reset button.

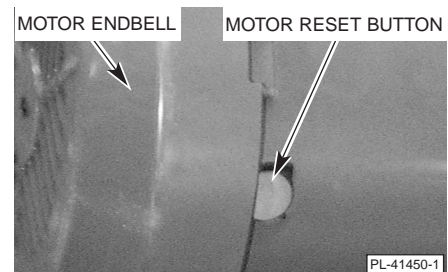

Fig. 14

To avoid a service call, check symptoms and related possible causes. If machine still does not operate properly, contact Service.

**SYMPTOM**

**POSSIBLE CAUSE**

No machine operation.

1. Blown fuse or tripped circuit breaker at power supply.
2. Machine control is in MANUAL mode.
3. Check tank water level.

---

Dishes not clean.

1. Insufficient wash water due to drain obstruction preventing proper drain closing.
2. Worn or torn drain "O" Ring allowing wash water to drain.
3. Loss of water pressure due to pump obstruction.

**DISCONNECT ELECTRICAL POWER SUPPLY (BOTH DISHWASHER AND BOOSTER IF APPLICABLE)** and drain tank. Check for any obstruction at the pump intake.

4. Incorrect water temperature. Check circuit breaker to electric heat supply.
5. Incorrect detergent dispensing. Contact your detergent representative.
6. Excessive mineral deposits throughout wash and rinse system. Deliming may be necessary.

---

Spotting silverware, glasses, and dishes.

1. Improperly loaded racks.
2. Incorrect rinse water temperature.
3. Loss of water pressure due to pump obstruction.

**DISCONNECT ELECTRICAL POWER SUPPLY (BOTH DISHWASHER AND BOOSTER IF APPLICABLE)** and drain tank. Check for any obstruction at the pump intake.

4. Excessively hard water.
5. Incorrect detergent for water type.
6. Incorrect rinse additive for water type.
7. Incorrect concentration of detergent, rinse additive and/or sanitizer.

## SYMPTOM

## POSSIBLE CAUSE

Inadequate rinse.

1. Dirty line strainer causing reduced water flow. Turn off water supply, remove strainer cap, withdraw and clean screen. Reassemble.
2. Low supply line pressure.
3. Excessive mineral deposits throughout wash and rinse system. Deliming may be necessary.
4. Incoming water temperature to booster (if applicable) below 120°F. Extend wash cycle from 40 to 60 seconds.

---

Leaking valve (except solenoid type).

1. Foreign material preventing proper valve operation. **NOTE:** A critical period is soon after installation when pipe compound or metal shavings may lodge at the valve seat. Shut off supply line. Unscrew and lift bonnet from valve body. Clean valve and reassemble.
2. If a solenoid valve is malfunctioning, it is recommended that you contact Service.

---

No wash tank heat.

1. The machine is equipped with a low water safety device which shuts off heat if the water level drops. Check for proper water level. If the water level is too low, the overflow tube might be out of position.
2. Circuit breaker to machine tripped.
3. Steam valve not open completely.
4. Gas line closed.

If a failure occurs due to the gas heat control board or gas pressure, the reset button, located on the side of the gas burner control box, will pop out. This completely shuts off the gas heat system. To reset the system, push the button in. If the system does not reset, contact Service.

---

No or slow fill.

1. Dirty line strainer causing reduced water flow. Turn off water supply, remove strainer cap, withdraw and clean screen. Reassemble.

## SERVICE

Contact your local Hobart-authorized service office for any repairs or adjustments needed on this equipment. If a gas orifice fitting is to be adjusted or replaced, have it serviced by qualified Hobart-authorized service personnel. Long-term service contracts are available on this and other Hobart products.