

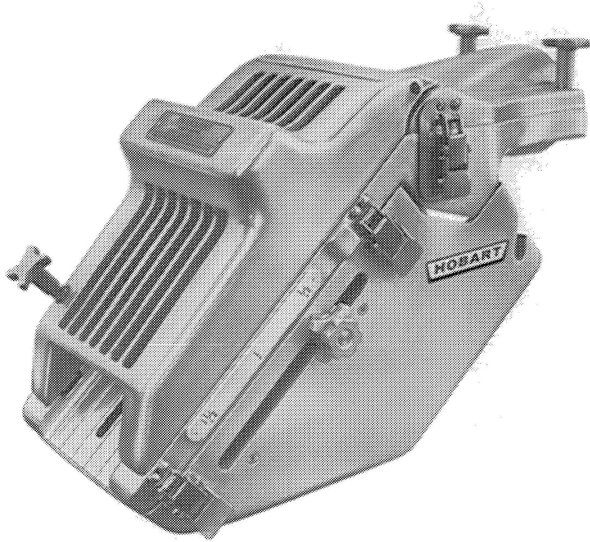

INSTRUCTION MANUAL

... with Replacement Parts



MODEL 80A MOLDING MACHINE

ML-32344

THIS MANUAL REPLACES AND SHOULD BE USED
INSTEAD OF FORM 13055 FOR REPLACEMENT PARTS

PRIOR ML COVERED IN THIS MANUAL:

ML-19568

Instructions for Operation and Care of MODEL 80A MOLDING MACHINE

Save These Instructions

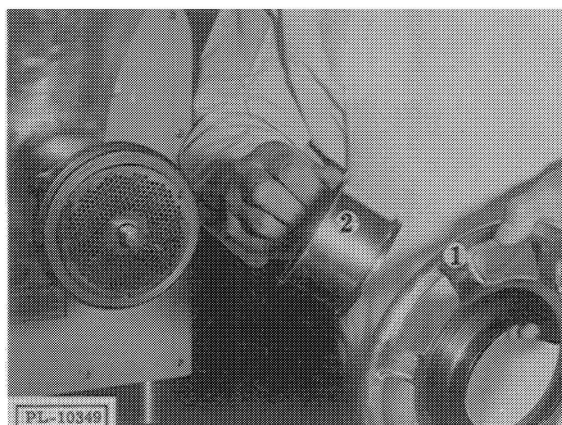

Fig. 1

I INSTALLATION:

1. The model 80A molding machine attaches to your chopper by means of an adapter (size 32, 42, 46, 52 & 56). Remove the chopper handwheel (1, Fig. 1) (allow

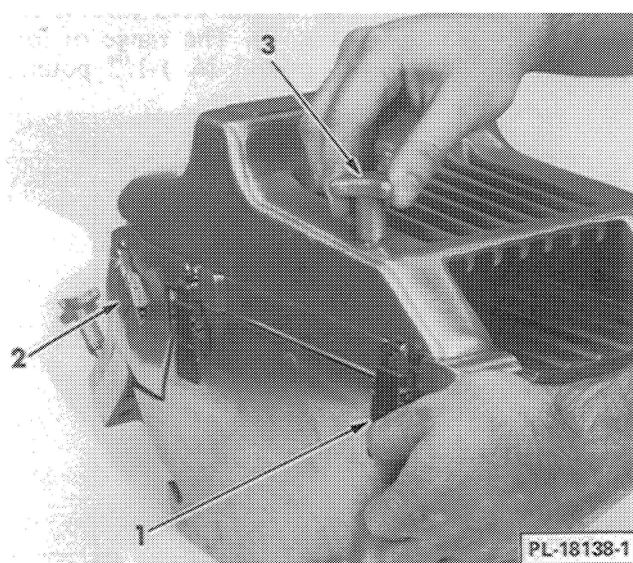

Fig. 2

chopper knife and plate to remain in chopper attachment). Assemble the flanged adapter through the handwheel. Replace handwheel with adapter on chopper and tighten handwheel firmly into position.

2. Place machine flat on table (chute parallel with table (Fig. 2)). Depress interlock knob (3, Fig. 2) rotate 90° counterclockwise. Release the one cover clamp (1, Fig. 2), then the two upper orifice clamps (2, Fig. 2) and the two clamping knobs (3, Fig. 3).
3. Raise the hinged cover (1, Fig. 3) and slide cover with orifice back to clear "L" shaped safety lock (2, Fig. 3). Remove cover and upper orifice from machine.

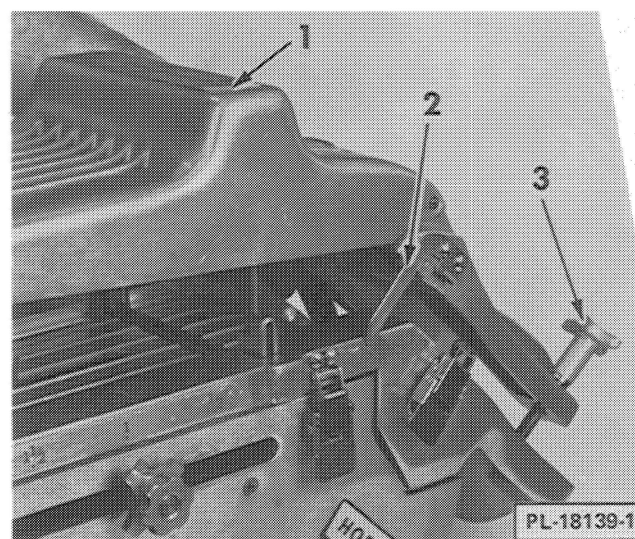

Fig. 3

4. Now place lower section of machine into position, so that groove and flange of chute (1, Fig. 4) mates with the flanged adapter which is attached to the chopper. To accomplish this operation, support the machine on the molder support stand or a table (or block) of the proper height.

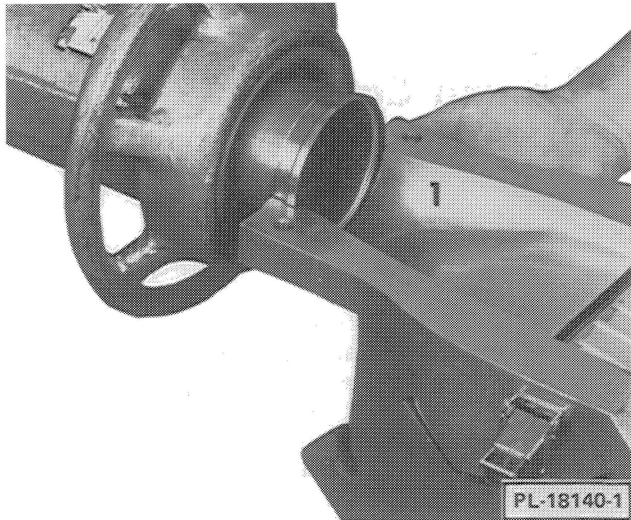

Fig. 4

- Remove the two cup shaped metal cores (if supplied) from the paper roll. Insert metal spindle (1, Fig. 8) through core of paper roll (2, Fig. 8). Place roll with spindle in notches so that paper unrolls over top of roll (not from underneath side).

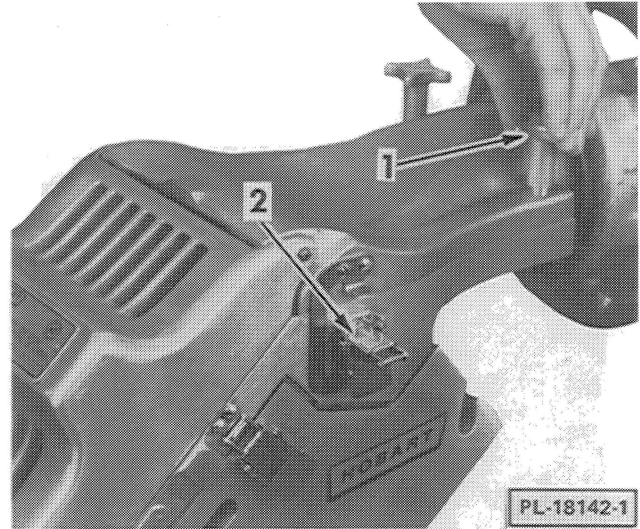

Fig. 6

- With the grilled cover in the "UP" position, slide cover with orifice forward so the "L" shaped safety lock (1, Fig. 5) is under clip (2, Fig. 5) as shown. Raise upper orifice (3, Fig. 5) so that groove and flange properly engage chopper adapter.

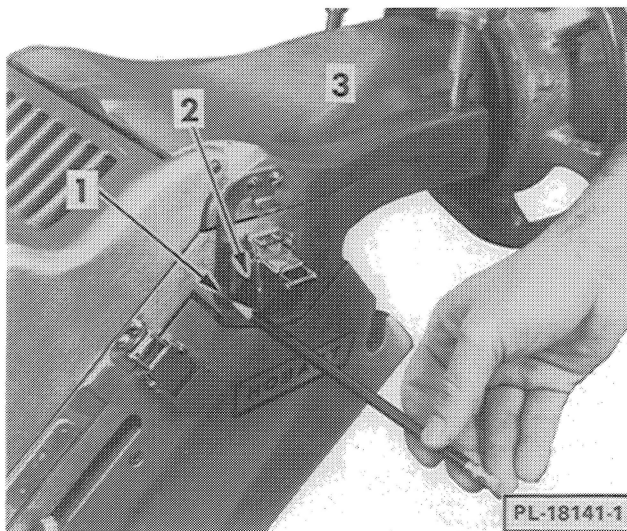

Fig. 5

- Thread paper through slot beneath forming orifice (Fig. 7). Push paper on down chute under knife.
- Close the grilled cover and clamp (1, Fig. 9) in place. Push interlock knob (2, Fig. 9) down and rotate 90° clockwise.
- Set the length adjustment by loosening the lock knob (5, Fig. 8) and then turning the outer knob (4, Fig. 8). The range of loaf size is from 1/2 pound to 1-1/2 pounds

- Tighten the two clamping knobs (1, Fig. 6), and latch the two orifice clamps (2, Fig.6).

II PREPARATION FOR OPERATION:

- WARNING:** Make sure power supply cord is unplugged.

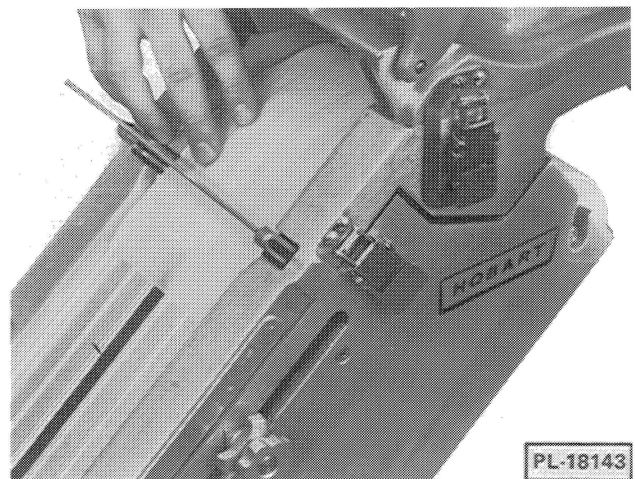

Fig. 7

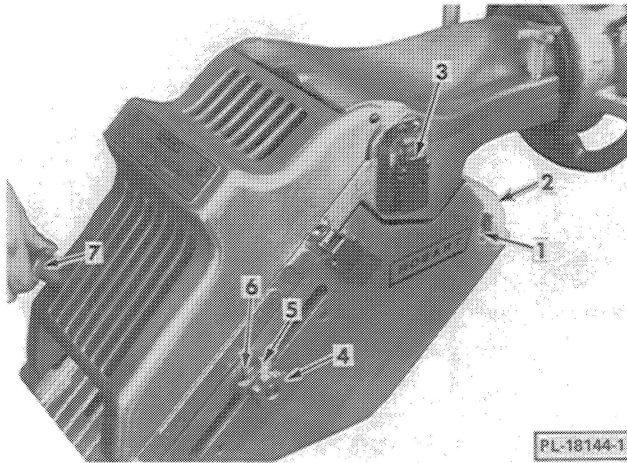

Fig. 8

or any increment in between. A pointer indicator (6, Fig. 8) shows approximately the 1/2, 1 and 1-1/2 pound settings.

III OPERATION:

1. Meat should be run through the chopper at least once before the molding machine is attached. For example use a 3/16" plate on the chopper (without the molder), then place a 1/8" plate in the chopper and attach the molder for the final grind.
2. Check the roll of paper and the roll spindle to make sure they are loose and free to turn.
3. Before making electrical connections CHECK THE SPECIFICATIONS ON THE NAME PLATE TO MAKE SURE THAT THEY AGREE WITH THOSE OF YOUR ELECTRICAL SERVICE. Plug in the electrical cord.
4. Feed the meat into the companion chopper. Feed steadily at a speed that the chopper worm is kept filled which will result in an even flow to the molder. The first loaf will have too much paper and should be withdrawn. Return the meat to the chopper and discard the paper.
5. The loaves slide down the chute by gravity, the operator catches the loaves, then stacks them on a tray (ready for packaging). Food processors may use the molding machine to feed the loaves directly onto a moving belt.
6. The speed of the operation depends upon the operator and the capacity of the chopper. The maximum output is approximately 60 pounds per minute.
7. An interlock knob (7, Fig. 8) attached to the cover, activates the safety interlock which prevents operation of the knife. To operate, close cover and lock it into place. Depress knob and rotate 90° clockwise into locked position. This will release the interlock allowing the knife to operate.

NOTE: Knife will not operate unless the interlock knob is rotated into the locked position.

IV PROPER OPERATION CHECK:

- A. If meat comes up through the grilled cover, check as follows:
 1. Frozen meat being used not tempered or soft enough. Recommended minimum meat temperature 32° F.
 2. Paper may be damp, and not feeding smoothly.
 3. Chute that paper slides on may be damp and need cleaning.
 4. Knife not cutting paper – may be caused by knife being clogged with meat. Clean knife and holder. Oil holder only (not knife).
- B. If meat comes out in a long strip without being cut:
 1. See that electrical cord is plugged in and extension cord is firmly connected.
 2. Interlock knob is not in locked position.
 3. Meat may not be taken from chute fast enough to allow trigger to snap back to position for next loaf to contact it. Be sure that loaf of meat is taken off chute immediately.
 4. Frozen meat being used is not tempered or soft enough.
- C. If meat comes out slowly and is very light in color:
 1. Chopper knife and plate are dull or not seated properly.

80A INSTRUCTIONS

2. Opening in chopper ring is too small to allow adapter to seat properly against inside of chopper ring.
3. Chopper plate is not properly engaged with plate stay pins in chopper head.
4. Make sure chopper ring is sufficiently tight.

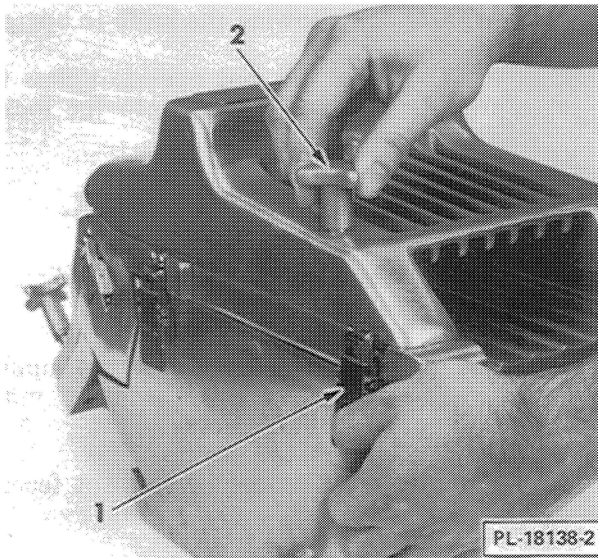

Fig. 9

V CLEANING:

1. **WARNING:** Unplug electrical supply cord.
2. Depress interlock knob (7, Fig. 8) and rotate 90° counterclockwise.
3. Release grilled cover clamp (1, Fig. 9) and raise cover up to raised position.
4. Remove exposed meat.
5. Remove paper.
6. Release the two orifice clamps (3, Fig. 8) and unscrew the two clamping knobs, holding the upper orifice slightly open to clear adapter, withdraw cover and orifice away from chopper to clear "L" shaped safety lock. Lift off cover and orifice.
7. Lift machine clear of adapter. Place machine flat on table (chute parallel with table (Fig. 10)).

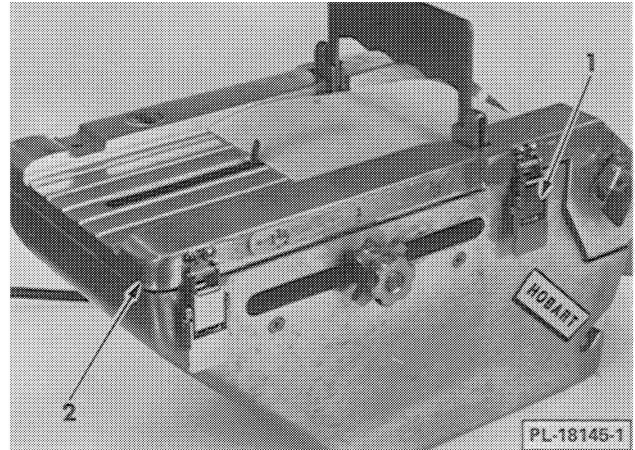

Fig. 10

8. Release the three chute clamps (1, Fig. 10) and remove chute (2, Fig. 10) from machine.
9. Lift insulating cover (Fig. 11) from housing.
10. Lift the blade and holder assembly free of housing.
11. The grilled cover and orifice (1, Fig. 12), the chute assembly (2, Fig. 12) and the blade and holder assembly (3, Fig. 12) may all be immersed and thoroughly washed in warm soapy water. After drying, lightly lubricate the blade holder with clear oil on both sides, but do not lubricate the knife. NEVER immerse the housing with its electrical components in water. The adapter may be cleaned with the chopper attachment.

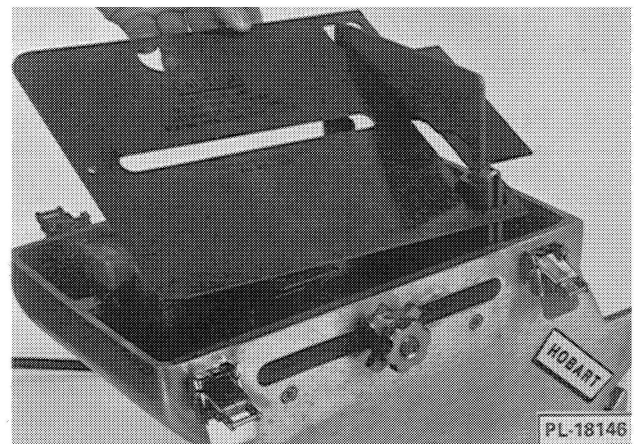

Fig. 11

12. Thoroughly clean the trigger mechanism occasionally to remove any fatty or gummy deposits. **DO NOT OIL THE TRIGGER MECHANISM.**

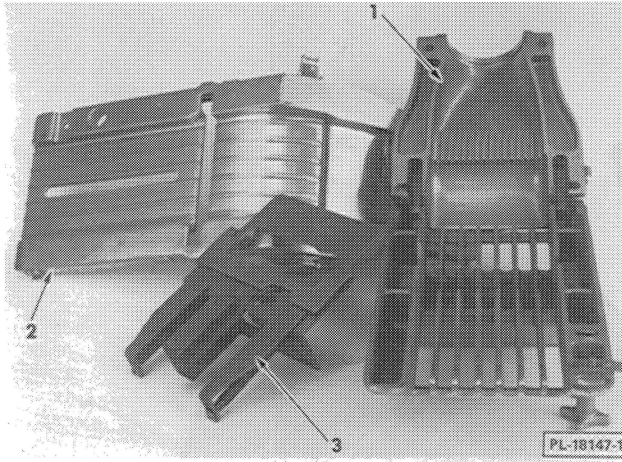

Fig. 12

VI PROPER MACHINE DIMENSION CHECK: (Disconnect electrical power supply)

A. Trigger:

1. Set pointer of length indicator at one (1) pound mark and actuate trigger.

The “click-in” point on the trigger should be between 5-1/8” and 5-1/4” from the knife.

B. Meat Clearance:

1. The distance between the points of the blade and the top of the holder lip must measure 1-5/8” + 1/32”.

VIII MISCELLANEOUS:

1. Lubrication:

The knife holder only is lubricated as described in cleaning instructions (section V, Par. 10).

2. Knife Sharpness:

It is not necessary for the knife to be sharpened. The paper is split by the knife, not cut or sheared.

3. Paper:

It is **IMPORTANT** that the correct type and size of paper be used with this machine. Paper should be ordered directly from your Hobart representative. One 400 ft. roll of paper is sufficient for approximately 1100 pounds of meat.

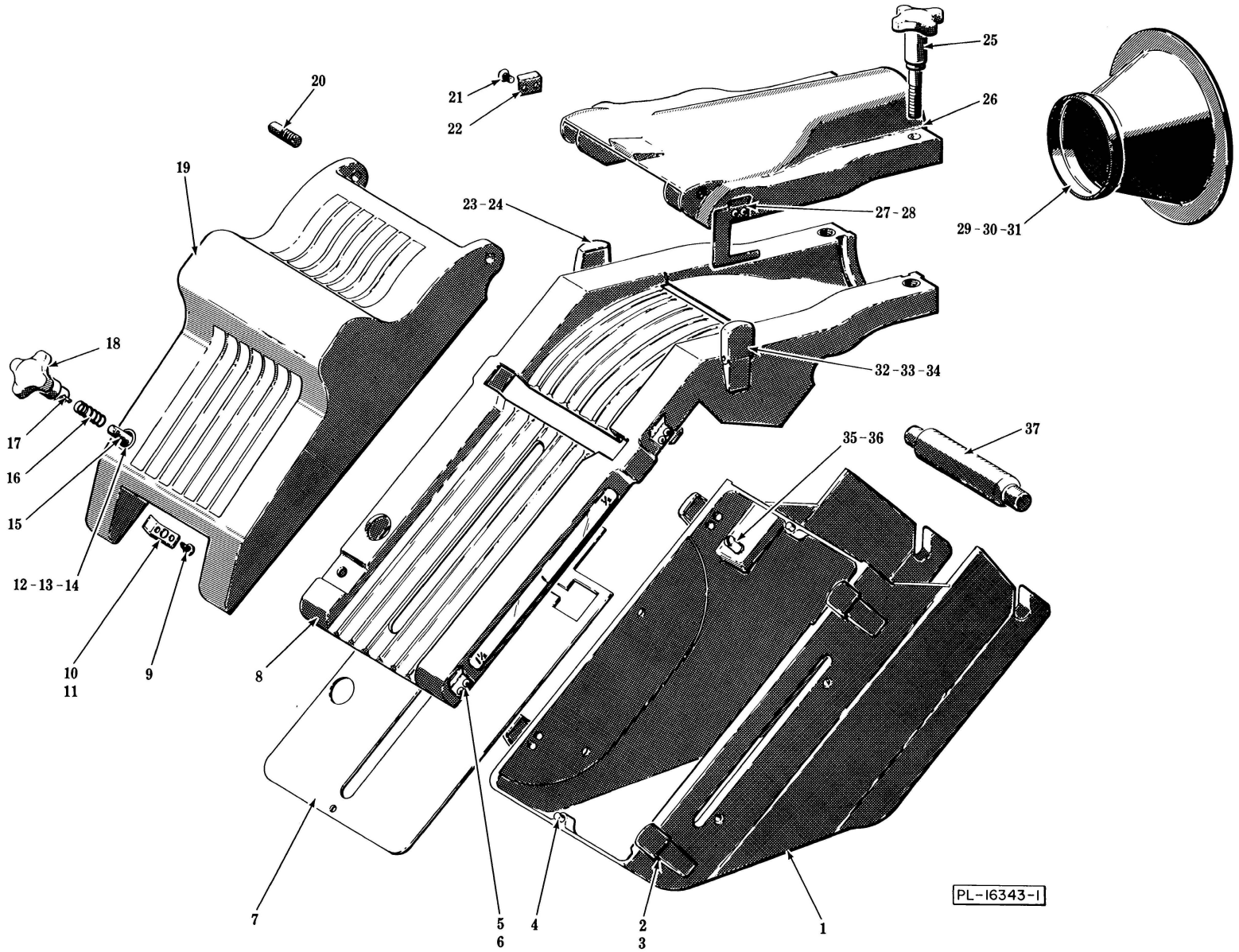

PL-16343-1

HOUSING UNIT
MACHINE ML-19568

**HOUSING UNIT
MACHINE ML-19568**

ILLUS. PL-16343-1	PART NO.	NAME OF PART	AMT.
*1	B-291204-1	Housing Assy. Service Kit	1
2	A-185014-2	Clamp - Toggle (Less Catch)	4
3	SD-33-18	Self-Tapping Screw - #10-24 x 3/8" Soc. Button Hd. "Taptite"	8
4	PG-6-2	Groov-Pin - Type D, 5/32" x 1/2"	2
5	A-185014-3	Catch - Toggle Clamp	3
6	SD-33-18	Self-Tapping Screw - #10-24 x 3/8" Soc. Button Hd. "Taptite"	6
7	D-124255-1	Cover - Insulating	1
*8	B-291399	Chute Assy. Service Kit	1
9	SD-33-18	Self-Tapping Screw - #10-24 x 3/8" Soc. Button Hd. "Taptite"	2
10	C-290728	Keeper	1
11	D-11800-244	Dowel	1
12	C-110629-8	Bearing - Sleeve (Outer)	1
13	C-110629-9	Bearing - Sleeve (Inner)	1
14	C-110649-11	Bearing - Thrust (Middle)	1
15	C-123998	Shaft - Key Lock	1
16	B-124002	Spring	1
17	PG-4-19	Groov-Pin - Type B, 3/32" x 1/2"	1
18	C-124007	Knob	1
19	D-291407-1	Cover & Bearing Assy. (Incls. items #12, 13 & 14)	1
20	M-76662	Pin - Hinge	2
21	SD-33-18	Self-Tapping Screw - #10-24 x 3/8" Soc. Button Hd. "Taptite"	2
22	A-185014-3	Catch - Toggle Clamp	1
23	A-185014-2	Clamp - Toggle (Less Catch)	1
24	SD-33-18	Self-Tapping Screw - #10-24 x 3/8" Soc. Button Hd. "Taptite"	2
25	B-124244	Knob Assy	2
*26	B-291400	Orifice Assy. Service Kit	1
27	SD-33-18	Self-Tapping Screw - #10-24 x 3/8" Soc. Button Hd. "Taptite"	2
28	B-185012	Lock - Safety	1
29	P-76685	Adapter - Size #32, 42 & 46 (Not Shown)	1
30	P-76695	Adapter - Size #52 (Not Shown)	1
31	P-76696	Adapter - Size #56	1
32	A-185014-2	Clamp - Toggle (Less Catch)	1
33	SD-33-18	Self-Tapping Screw - #10-24 x 3/8" Soc. Button Hd. "Taptite"	2
34	A-185016	Guide - Safety Lock	1
35	M-76662	Pin - Blade Holder	2
36	NS-15-1	Full Nut - 1/4"-20 Hex Fin	2
37	M-76220	Spindle - Paper	1
	M-76479	Paper - Roll (Plain)	1
	M-76481	Paper - Roll (Silicon)	1

*Kits required to Convert to New Style Clamps (See Page 11).

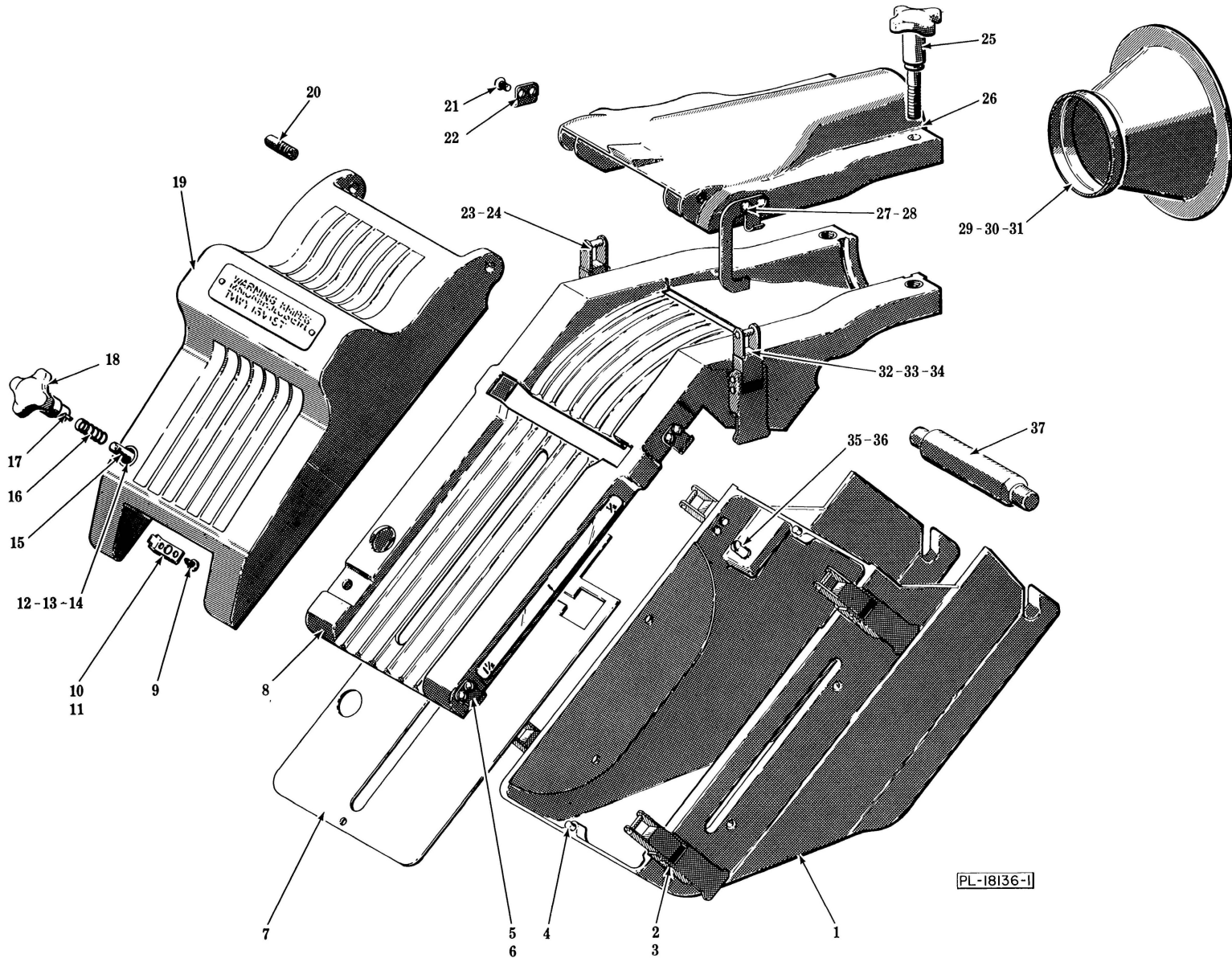

PL-18136-1

HOUSING UNIT
MACHINE ML-32344

**HOUSING UNIT
MACHINE ML-32344**

ILLUS. PL-18136-1	PART NO.	NAME OF PART	AMT.
1	E-290660-1	Housing Assy. (Incls. items #2, 3, 4, 35, 36 and 8 & 40 on Pg. 15)	1
2	C-290711-2	Clamp (Less Catch)	4
3	SD-24-19	Self-Tapping Screw - #8-32 x 3/8" Truss Hd., Type TT	8
4	PG-6-2	Groov-Pin - Type D, 5/32" x 1/2"	2
5	C-290711-3	Catch	3
6	SD-24-19	Self-Tapping Screw - #8-32 x 3/8" Truss Hd., Type TT	6
7	D-124255-1	Cover - Insulating	1
8	D-291405	Chute & Scale Assy. (Incls. items #5, 6, 23, 24, 32, 33 & 34)	1
9	SD-33-18	Self-Tapping Screw - #10-24 x 3/8" Soc. Button Hd. "Taptite"	2
10	B-290728	Keeper	1
11	PG-6-27	Groov-Pin - Type D, 1/4" x 3/4"	1
12	C-110629-8	Bearing - Sleeve (Outer)	1
13	C-110629-9	Bearing - Sleeve (Inner)	1
14	C-110649-11	Bearing - Thrust (Middle)	1
15	C-123998	Shaft - Key Lock	1
16	B-124002	Spring	1
17	PG-4-19	Groov-Pin - Type B, 3/32" x 1/2"	1
18	C-124007	Knob	1
19	D-291407-1	Cover & Warning Plate Assy. (Incls. items #12, 13 & 14)	1
20	M-76662	Pin - Hinge	2
21	SD-24-19	Self-Tapping Screw - #8-32 x 3/8" Truss Hd., Type TT	2
22	C-290711-3	Catch	1
23	C-290711-2	Clamp (Less Catch)	1
24	SD-24-19	Self-Tapping Screw - #8-32 x 3/8" Truss Hd., Type TT	2
25	B-124244	Knob Assy	2
26	C-291203	Orifice Assy. (Incls. items #21, 22, 27 & 28)	1
27	SD-24-19	Self-Tapping Screw - #8-32 x 3/8" Truss Hd., Type TT	2
28	D-290729	Lock - Safety	1
29	P-76685	Adapter - Size #32, 42 & 46 (Not Shown)	1
30	P-76695	Adapter - Size #52 (Not Shown)	1
31	P-76696	Adapter - Size #56	1
32	C-290711-2	Clamp (Less Catch)	1
33	SD-24-19	Self-Tapping Screw - #8-32 x 3/8" Truss Hd., Type TT	2
34	C-290730	Guide - Safety Lock	1
35	M-76662	Pin - Blade Holder	2
36	NS-15-1	Full Nut - 1/4"-20 Hex Fin	2
37	M-76220	Spindle - Paper	1
	M-76479	Paper - Roll (Plain)	1
	M-76481	Paper - Roll (Silicon)	1

LENGTH ADJUSTMENT UNIT

ILLUS. PL-18137	PART NO.	NAME OF PART	AMT.
1	RR-4-25	Retaining Ring	1
2	WS-8-49	Washer	1
3	M-76129	Cam Assy	1
4	M-76145	Pinion	1
5	B-76682	Key - #403 Woodruff	1
6	B-76147	Stud	1
7	M-76148	Pointer	1
8	B-76149	Nut - Adjusting	1
9	M-76150	Knob - Adjusting	1
10	SC-47-73	Set Screw - #8-32 x 3/16" Soc. Hdls., Cup Pt	1
11	M-76152	Bracket	1
12	SC-22-65	Mach. Screw - #10-32 x 7/8" Phil. Flat Hd	2
13	WS-22-4	Washer	1
14	RR-4-26	Retaining Ring	1
15	M-76151	Rack	1
16	M-76133	Cam	1
17	S-76134	Trigger, Switch & Base Assy. (Incls. items #18 thru 38)	1
*18	B-290944	Switch Base Assy	1
*19	NS-36-3	Stop Nut - #6-32 "Elastic"	2
*20	M-76136	Switch - Actuator	1
*21	M-76672	Cover - Actuator Switch	1
*22	SC-25-31	Mach. Screw - #6-32 x 1-1/4" Bind. Hd	2
*23	C-76137-1	Plate - Switch	1
*24	M-76035	Trigger	1
*25	M-76036	Clamp	1
*26	SD-29-9	Self-Tapping Screw - #4-40 x 1/4" Pan Hd., Type F	2
*27	WL-6-43	Lock Washer - #4 Medium	2
*28	M-76139	Counterweight	1
*29	SC-47-73	Set Screw - #8-32 x 3/16" Soc. Hdls., Cup Pt	1
*30	M-76140	Eccentric	1
*31	M-76040	Pin - Cam	1
*32	M-76039	Cam - Actuator	1
*33	RR-6-4	Retaining Ring	2
*34	C-291258	Cam Link & Roll Pin Assy	1
*35	M-76144	Washer	1
*36	M-76029	Spring - Link	1
*37	M-76144	Washer	1
*38	B-124362	Insulator - Switch	1
	M-76146	Adjusting Knob Assy. (Incls. items #5, 6, 7, 8, 9 & 10)	1
	P-76138	Trigger Assy. (Incls. items #24, 25, 26, 27, 28 & 29)	1

*Individual parts (due to precision settings) should not be replaced
except by a qualified technician.

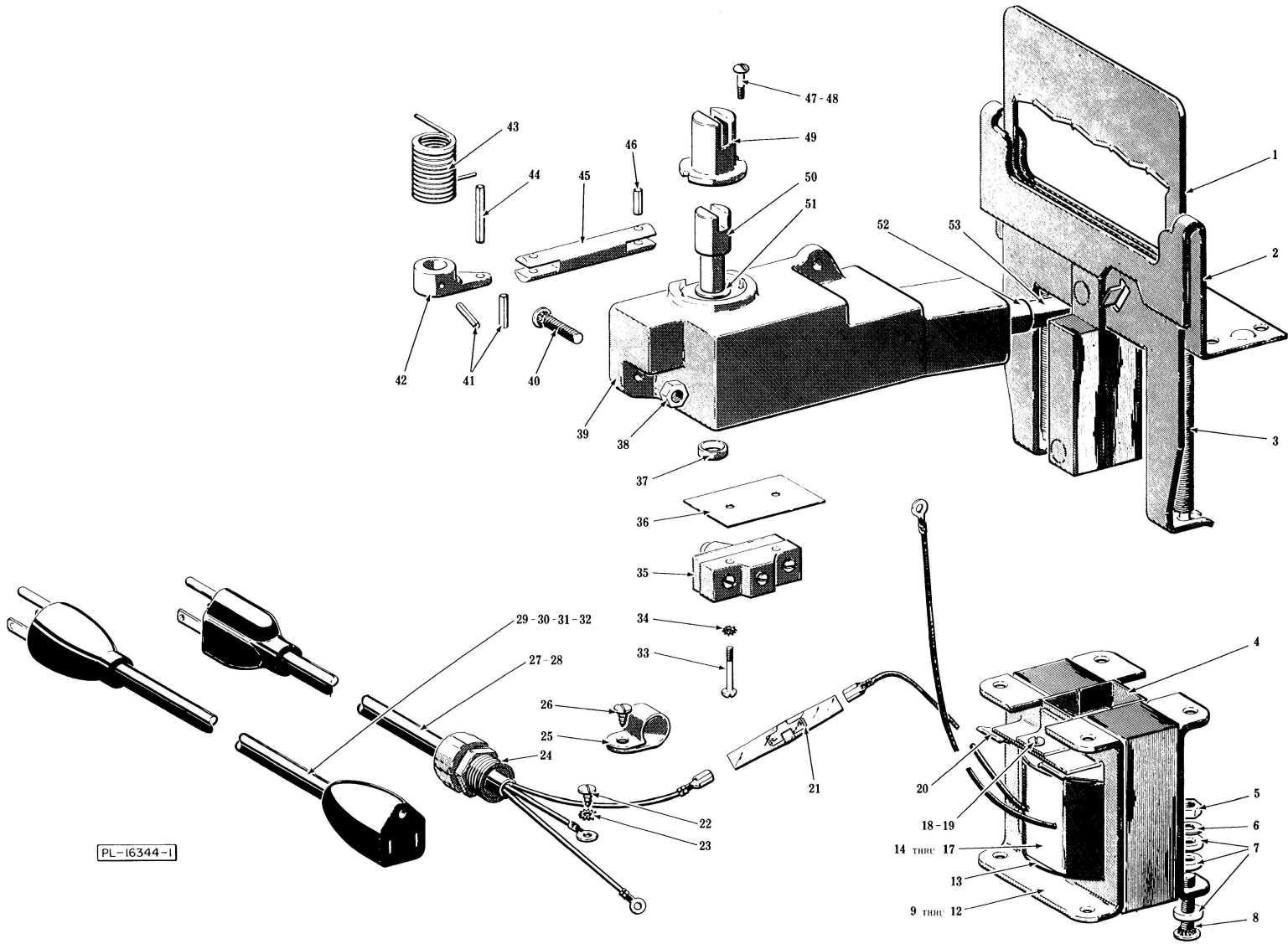

PL-16344-1

SAFETY SWITCH, SOLENOID AND BLADE HOLDER UNIT

SAFETY SWITCH, SOLENOID AND BLADE HOLDER UNIT

ILLUS. PL-16344-1	PART NO.	NAME OF PART	AMT.
1	C-76835	Knife Assy	1
2	C-76836	Holder - Knife	1
3	M-76742	Spring Assy	2
4	C-124397	Guide - Plunger	2
5	NS-17-3	Jam Nut - 1/4"-20 Hex Fin	4
6	WS-22-8	Washer (1/32" Thk.)	4
7	WS-22-3	Washer (Neoprene)	12
8	C-113631-15	Stud - Self Clinching	4
9	E-124262-1	Solenoid Assy. (115 V., 60 Hz., 1 Ph.) (Incls. items #4, 13, 14, 18, 19 & 20)	1
10	E-124262-2	Solenoid Assy. (230 V., 60 Hz., 1 Ph.) (Incls. items #4, 13, 15, 18, 19 & 20)	1
11	E-124262-3	Solenoid Assy. (115 V., 50 Hz., 1 Ph.) (Incls. items #4, 13, 16, 18, 19 & 20)	1
12	E-124262-4	Solenoid Assy. (220 V., 50 Hz., 1 Ph.) (Incls. items #4, 13, 17, 18, 19 & 20)	1
13	C-124398	Washer - Coil	2
14	C-124395-1	Coil (115 V., 60 Hz., 1 Ph.)	1
15	C-124395-2	Coil (230 V., 60 Hz., 1 Ph.)	1
16	C-124395-3	Coil (115 V., 50 Hz., 1 Ph.)	1
17	C-124395-4	Coil (220 V., 50 Hz., 1 Ph.)	1
18	SC-60-56	Mach. Screw - #10-32 x 5/16" Rd. Hd	2
19	WL-4-40	Lock Washer - #10 Medium	2
20	C-124399	Spring - Coil	2
21	C-65890-85	Splice - Line	1
22	SD-24-1	Self-Tapping Screw - #10-24 x 3/8" Pan Hd. "Taptite"	1
23	WL-7-12	Lock Washer - #10 Ext. Shakeproof	1
24	FE-6-31	Strain Relief	1
25	M-69193-2	Clip - Cord	1
26	SD-24-1	Self-Tapping Screw - #10-24 x 3/8" Pan Hd. "Taptite"	1
27	C-117542-40	Cord Set - Short (115 V.)	1
28	C-117542-41	Cord Set - Short (230 V.)	1
29	M-76678-1	Cord Set (10 Ft.) (115 V., 60 Hz., 1 Ph.)	1
30	M-76678-2	Cord Set (10 Ft.) (230 V., 60 Hz., 1 Ph.)	1
31	A-76882-1	Cord Set (10 Ft.) (115 V., 50 Hz., 1 Ph.)	1
32	A-76882-2	Cord Set (10 Ft.) (220 V., 50 Hz., 1 Ph.)	1
33	SC-9-64	Mach. Screw - #6-32 x 1" Rd. Hd	2
34	WL-7-2	Lock Washer - #6 Ext. Shakeproof	2
35	M-76136	Switch - Actuator	1
36	B-124362	Insulator - Switch	1
37	C-110629-10	Bearing - Thrust	1
38	NS-13-2	Full Nut - 1/4"-20 Hex Fin	2
39	E-123999	Housing - Interlock	1
40	C-113631-15	Stud - Self Clinching	2
41	RP-3-7	Rollpin - .187" Dia. x 3/4" Lg	2
42	B-123992	Arm	1
43	B-124003	Spring - Torsion	1
44	RP-2-7	Rollpin - .187" Dia. x 1-1/8" Lg	1
45	B-123986	Link	1
46	RP-6-4	Rollpin - .187" Dia. x 1/2" Lg	1
47	SC-7-68	Mach. Screw - #8-32 x 5/8" Rd. Hd	2
48	NS-31-8	Stop Nut - #8-32 "Elastic"	2
49	C-123997	Cap - Shaft	1
50	C-123985	Shaft	1
51	C-105981-7	Bearing - Flange	1
52	C-110629-8	Sleeve - Bearing	1
53	B-123994	Pin - Locking	1
	C-76837	Knife Assy. (Incls. items #1, 2 & 3)	1

