

INSTRUCTIONS

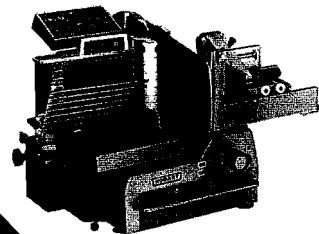

MODEL 3100 & 3100C STACKING SLICER

ML-104493 3100
ML-104494 3100C



701 S. RIDGE AVENUE
TROY, OHIO 45374-0001

TABLE OF CONTENTS

GENERAL	3
INSTALLATION	3
UNPACKING	3
ASSEMBLY	5
TEST SLICER OPERATION	10
ELECTRICAL	10
TRAINING	10
OPERATION	11
SAFETY	11
BEFORE FIRST USE	11
CONTROLS	12
SELECTING LAYOUT OPTIONS	13
THE KEYPAD	15
BASIC LAYOUTS — RECTANGULAR TRAY	16
MULTIPLE LAYOUTS — RECTANGULAR TRAY	18
BASIC LAYOUTS — ROUND PLATTER	19
MULTIPLE LAYOUTS — ROUND PLATTER	20
SANDWICH PACKAGE LAYOUTS	20
EXAMPLES	21
SLICING	22
MANUAL	22
AUTOMATIC	23
RECLAMPING	24
REPROGRAMMING FACTORY PRESET VALUES	25
CLEANING	27
MAINTENANCE	30
SHARPENING THE KNIFE	30
LAYOUT PROBLEMS	32
LUBRICATION	32
WEAR ADJUSTMENT	32

Installation, Operation and Care of MODEL 3100 & 3100C STACKING SLICER

SAVE THESE INSTRUCTIONS FOR FUTURE USE

GENERAL

Your Hobart Model 3100 or 3100C Stacking Slicer is to be used to slice meats and cheeses only. Model 3100C is equipped with a conveyor. A Model 3100 Slicer cannot be field converted to a Model 3100C. Both models feature two slicing speeds: 40 or 60 strokes per minute.

The slicer is an electronically controlled, programmable system for manual or automatic slicing. On the Model 3100 Slicer, the slices can be deposited on a tray or round platter. On Model 3100C, the slices are deposited on the conveyor, tray, or round platter.

For best results with the Hobart stacking slicer, your staff must be carefully instructed in the operation and care of the slicer in accordance with this manual. Only trained staff should operate the slicer.

Before operating your stacking slicer for the first time, read this manual through carefully. It gives details of correct installation, operation and care, and will show you how to make the most of your slicing system.

Improper installation, electrical or otherwise, incorrect operation, improper use, alterations to the machine or use of anything other than Hobart original spare parts and accessories, use of any lubrications, etc., not recommended by Hobart, or repairs carried out by an unauthorized agent may void the warranty.

INSTALLATION

UNPACKING

It will require two people to lift the slicer from the box. Lift slicer using the two bars on either side of the machine and the bar in front (Fig. 1).

Immediately after unpacking the slicer, check for possible shipping damage. If the slicer is found to be damaged, save the packaging material and contact the carrier within 15 days of delivery.

Prior to installation, verify that the electrical service agrees with the specification on the machine data plate which is located on the right side under the carriage.

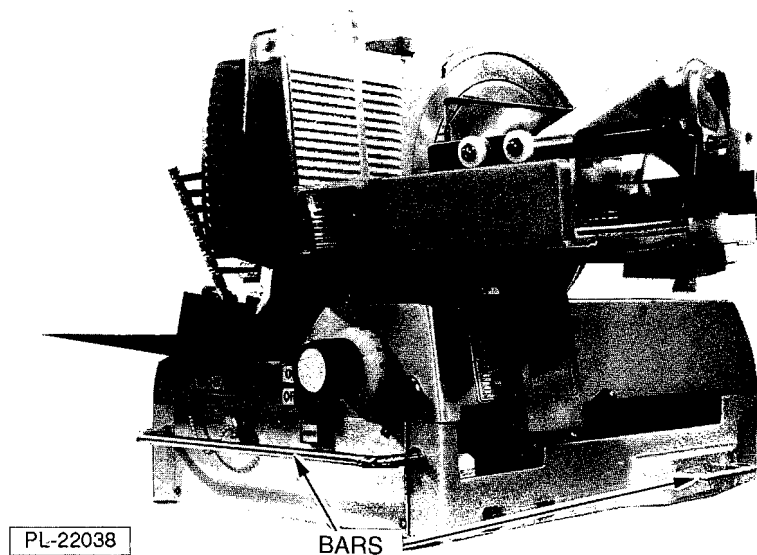

Fig. 1

Ensure the correct accessories are included in the box (Fig. 2). (NS=Not Shown)

MODEL 3100

Standard Accessories

Transport System
 Depositor
 Interleaf Strip Dispenser (NS)
 Round Platter
 Rectangular Platter (NS)
 Sharpener
 (2) Cleaning Brushes
 Scrap Collector (NS)

Optional Accessories

Foot Switch (NS)
 Chipping/Shaving Depositor
 Sandwich Package
 3100-3100C Table (NS)
 3100-3100C Shelf (NS)
 Fork
 (2) Peels (for lifting sliced product from conveyor belt or tray) (NS)
 Round Peel (for lifting sliced product from round platter) (NS)

MODEL 3100C

Standard Accessories

Transport System
 Depositor
 Interleaf Strip Dispenser (NS)
 Conveyor System (NS)
 Foot Switch (NS)
 Sharpener
 Round Platter
 Rectangular Platter (NS)
 (2) Cleaning Brushes
 Handle Assembly (NS)
 (for mounting conveyor)
 Scrap Collector (NS)

Optional Accessories

Chipping/Shaving Depositor
 Sandwich Package
 3100-3100C Table (NS)
 3100-3100C Shelf (NS)
 Fork
 (2) Peels (for lifting sliced product from conveyor belt or tray) (NS)
 Round Peel (for lifting sliced product from round platter) (NS)

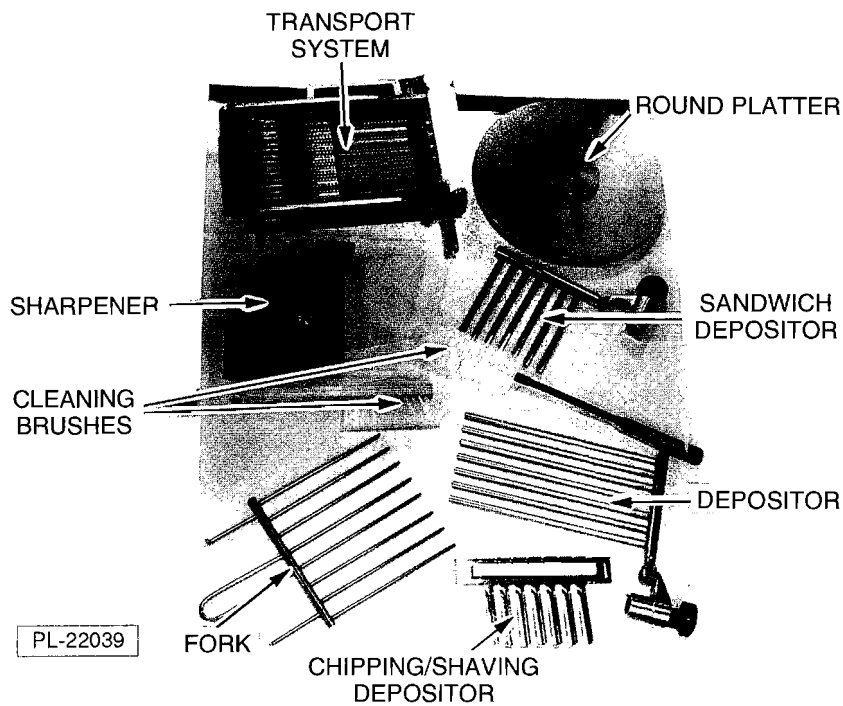

Fig. 2

ASSEMBLY

Transport System

Hold the handle at the top of the transport system with your left hand, and with your right hand, swivel the tension roller (Fig. 3) over to the left.

Make sure the transport system is vertical and engaged on all three points illustrated (drive shaft in the center, transport support at the top, and bumper assembly on the left).

If the notch does not fully engage on the projection (see Fig. 3) on the drive shaft (protrudes from the machine), turn the knurled knob below the roller with your right hand. The drive pin aligns with the slots in the drive shaft, and will drop into place.

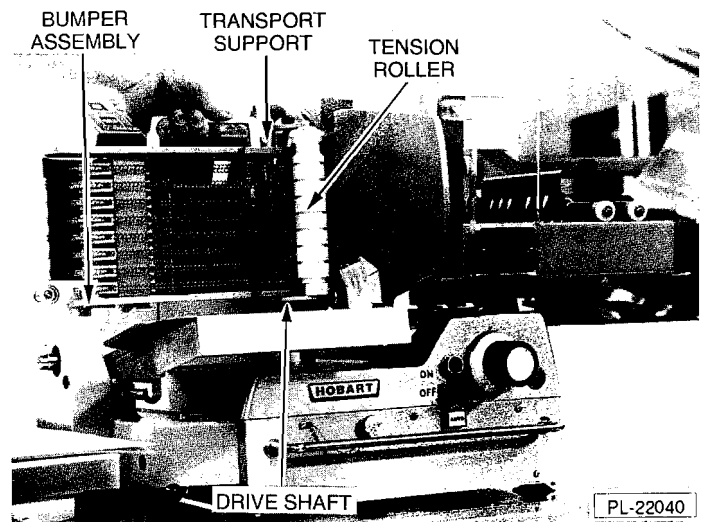

Fig. 3

Depositor

Mount the depositor into its drive mechanism on the left-hand side of the slicer. First ensure that the depositor is fitted vertically. Only in this position can the projection on the knob engage properly.

Tighten the knob (Fig. 4) to secure the mechanism. This knob is permanently mounted so there is no danger of losing it when you remove the depositor.

Sandwich Package (Optional)

Mount sandwich depositor in same manner as depositor.

The sandwich package includes new software that must be installed by the technician upon installation.

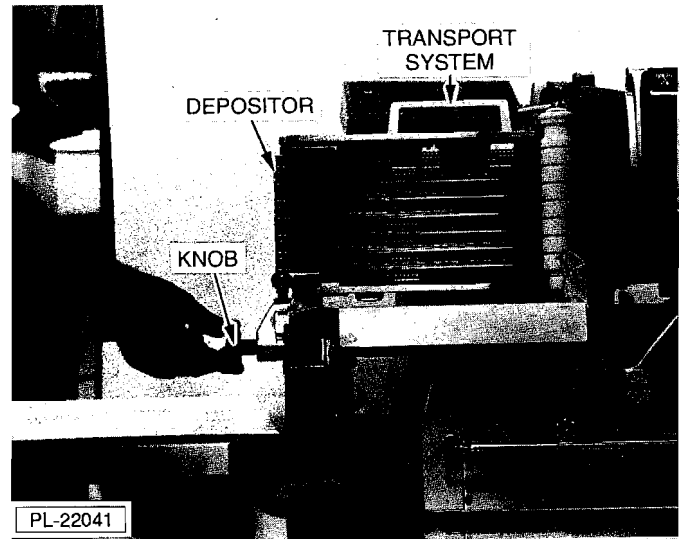

Fig. 4

Chipping/Shaving Depositor (Optional)

Slide slot at bottom of chipping/shaving depositor onto the tab at the bottom of the transport system. Snap top of depositor onto bar at top of transport system (Fig. 5).

Only one type of depositor may be used at a time.

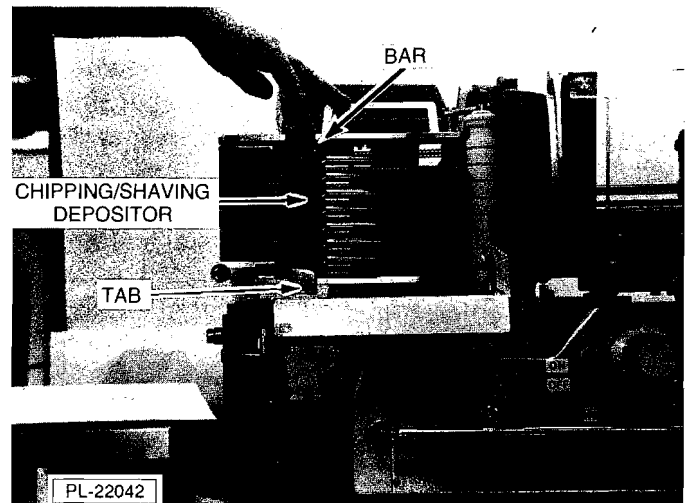

Fig. 5

Interleaf Strip Dispenser

Insert the interleaf strip dispenser into the holder on the tray (Fig. 6) and push all the way in. (Series of interleaf paper can be manually positioned between horizontally shingled rows.)

Set up slicer for horizontal shingle with one row. Pull interleaf paper over product after each row is sliced.

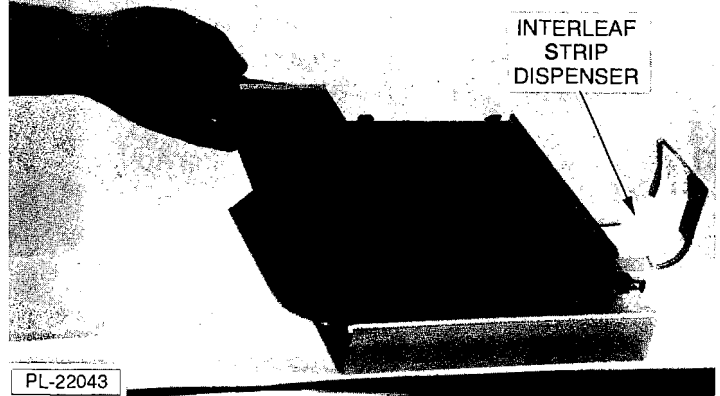

Fig. 6

Scrap Collector

From the back of the slicer, slide the scrap collector (Fig. 7) under the ring guard. The notch in the scrap collector fits over the ring guard support (Fig. 7).

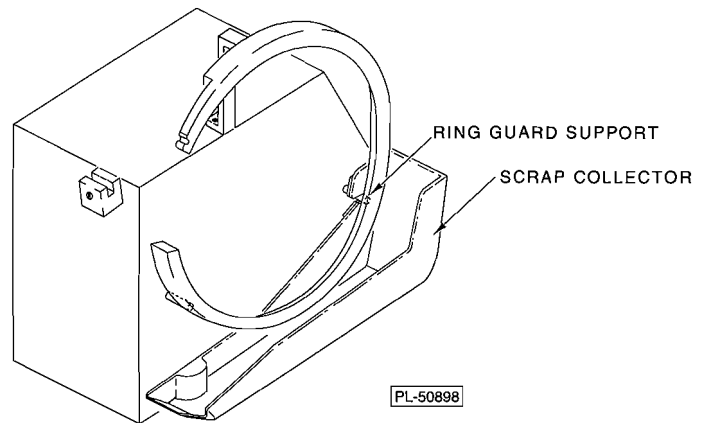

Fig. 7

Rectangular Tray

On the back left-hand edge of the tray there is a guide. Holding the tray at an angle, push the guide onto the stud at the back of the tray rod (Fig. 8) and lower the front of the tray onto the pin at the front of the tray rod (Fig. 8). Push the tray down so that the pin fits into the white plastic bushing on the bottom of the tray. The tray will remain at a slight angle.

Turn slicer off before changing to round platter (or conveyor system on the Model 3100C).

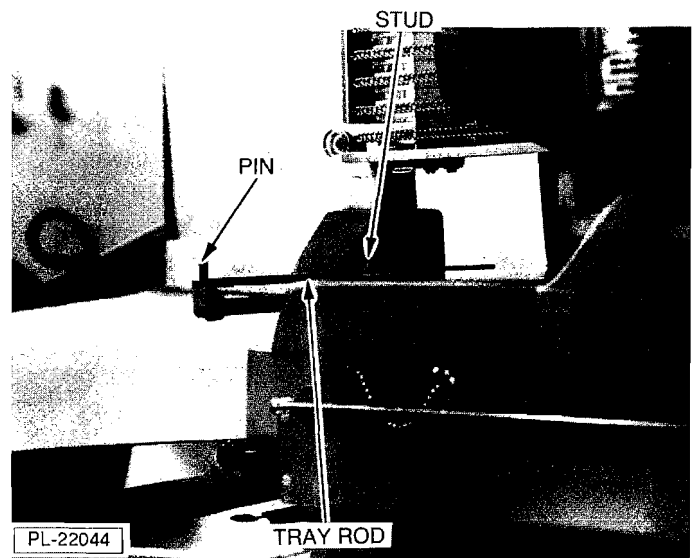

Fig. 8

Round Platter

Push the round platter drive opener to the right (Fig. 9). A small cover plate opens. Insert the pin of the round platter into its drive receptacle under the cover plate. To allow the projection to lock in properly, turn the platter slightly.

The slicer is now automatically programmed for round platter operation.

Turn slicer off before changing to rectangular tray (or conveyor system on Model 3100C).

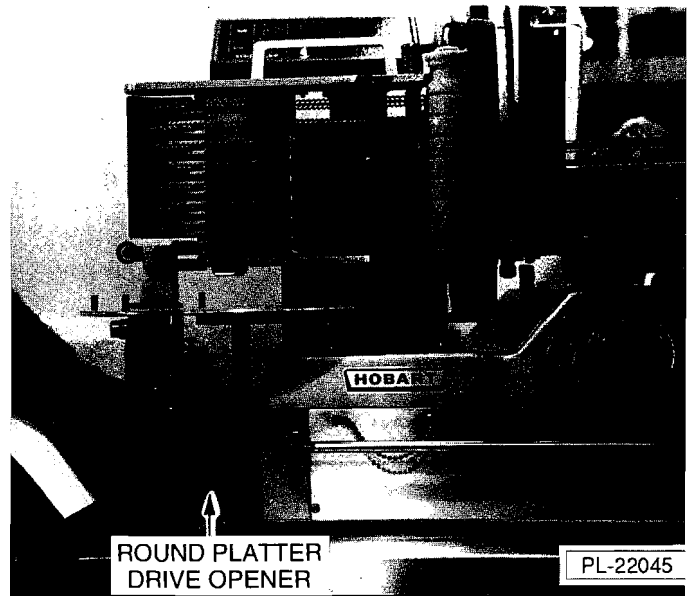

Fig. 9

Conveyor Belt (Model 3100C Only)

Mount the handle assembly (Fig. 10). Fit the conveyor to the depositor drive housing on the left and to the handle assembly on the right. Tighten the two black knobs (Fig. 11). The conveyor should be level.

When the slicer is turned on, a pin on the tray rod automatically locks onto a notch on the follower on the underside of the conveyor (Fig. 12). It can only do so if the notch is in front of the tray rod.

If the pin does not automatically lock onto the notch, manually push the notched piece forward until it locks onto the pin.

Turn slicer off before changing to rectangular tray or round platter.

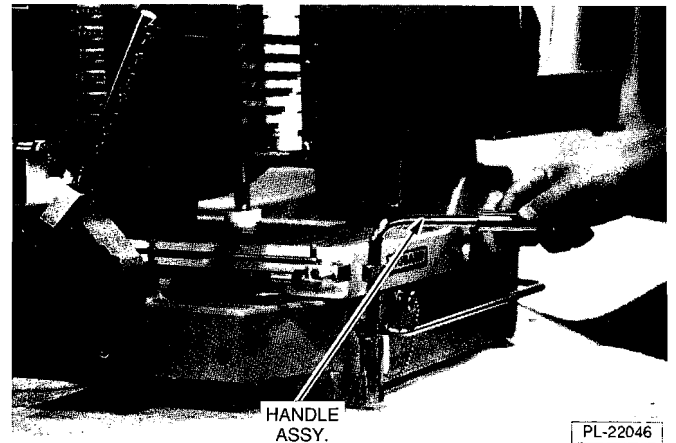
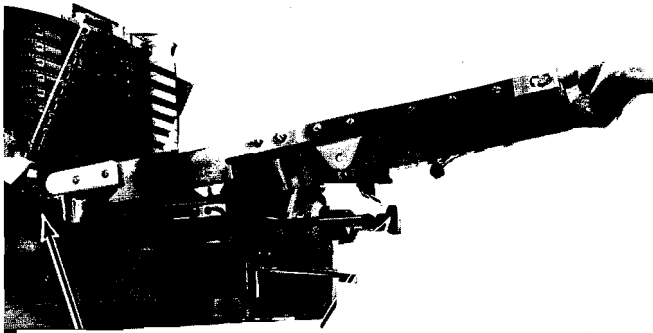

Fig. 10



DEPOSITOR
DRIVE HSG.
KNOB

HANDLE
ASSY. KNOB

PL-22047

Fig. 11

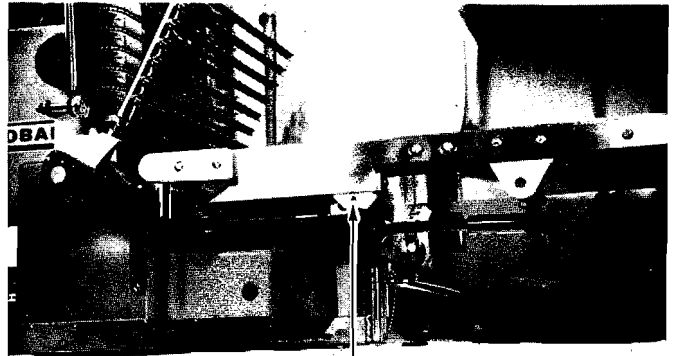

FOLLOWER

PL-22048

Fig. 12

Foot Switch

Unscrew the foot switch port cover (Fig. 13). Plug in the foot switch and tighten the connector (Fig. 14). The foot switch is used to start or stop the automatic carriage operation.

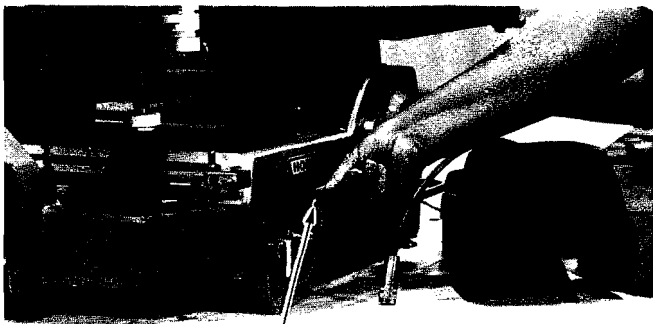

FOOT SWITCH
PORT COVER

PL-22049

Fig. 13

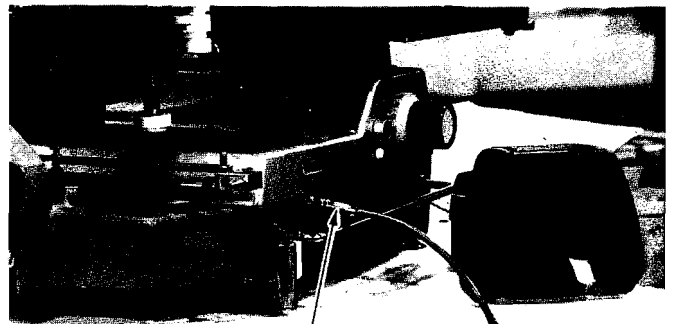

CONNECTOR

PL-22050

Fig. 14

TEST SLICER OPERATION

Once assembly is completed, test all functions.

ELECTRICAL

WARNING: THIS MACHINE IS PROVIDED WITH A THREE-PRONG GROUNDING PLUG. IT IS IMPERATIVE THAT THE OUTLET TO WHICH THIS PLUG IS CONNECTED BE PROPERLY GROUNDED. IF THE RECEPTACLE IS NOT THE PROPER GROUNDING TYPE, CONTACT AN ELECTRICIAN.

TRAINING

All staff who will be operating this slicer must receive in-depth training in the use of the slicer. This training is available through your local Hobart representative.

OPERATION

SAFETY

SAFETY DEVICES INCORPORATED IN THIS SLICER MUST BE IN THEIR CORRECT OPERATING POSITIONS ANYTIME THE SLICER IS IN USE.

The KNIFE COVER (Fig. 15) must be in position and secured.

When slicing in the manual mode, the MEAT GRIP HANDLE (Fig. 15) must be used when slicing short ends to keep your hands away from the knife.

When the slicer is not running, the SLICE THICKNESS CONTROL (Fig. 15) must be turned back (clockwise) as far as it will go (past zero). The gauge plate will then cover the knife edge.

Always UNPLUG the power cord before cleaning or moving the slicer.

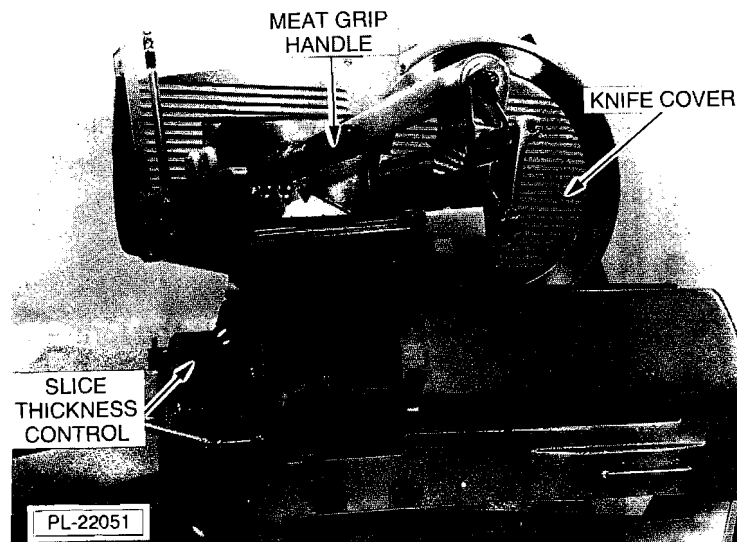

Fig. 15

BEFORE FIRST USE

Before using the slicer for the first time, please read this manual carefully.

Clean the machine before using it for the first time (see CLEANING in this manual).

CONTROLS (Fig's. 16 & 17)

ON Switch (Green) — Turns main power to keyboard ON; keyboard and switch light are ON.

OFF Switch (Red) — Turns main power OFF.

CAUTION: If you press the Main OFF Switch (red button) while the machine is slicing, all power, including automatic operation of the carriage, will stop and the carriage may not reach its home position. If this occurs, you cannot tilt it, e.g., for cleaning. To bring the carriage to the home position, press the ON switch, then press the SLICE Switch ON and then OFF again. Do not use force to move the carriage because to do so may damage the drive.

SLICE Switch — With Carriage Latch on AUTOMATIC, turns both knife and carriage ON; stays on until the pattern is complete.

With Carriage Latch on MANUAL, turns only the knife ON; knife shuts off if the carriage is not moved in 10 seconds.

Switch light is ON to indicate the knife is on.

Carriage Latch — **AUTOMATIC** — Carriage moves back and forth automatically when SLICE is pressed.

MANUAL — Carriage must be pushed manually when SLICE is pressed.

Slice Thickness — Turn knob to adjust slice thickness.

Keyboard — Selects Pattern, Slices, Rows.

Carriage — During slicing, moves product back and forth across the knife edge.

Carriage Speed Switch — Sets carriage speed. Push carriage speed switch to the left (toward the one dot) for low speed; push switch to the right (toward the two dots) for high speed.

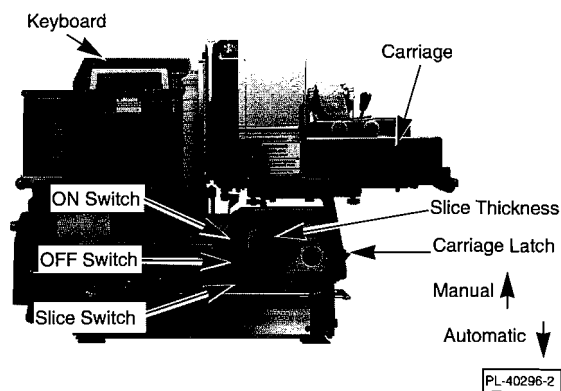

Fig. 16

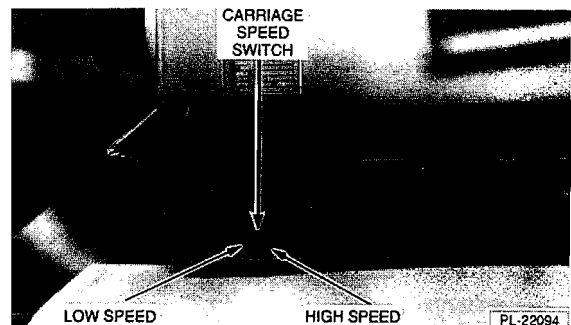
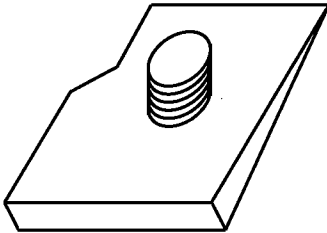

Fig. 17

SELECTING LAYOUT OPTIONS

There are four basic forms of layout on the tray (Fig. 18).

Stacks (For Preslicing)



Circles (Party Trays or Merchandising Displays)

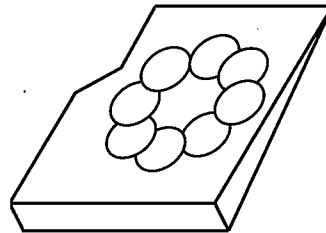

Horizontal Shingles (For Tray-covering Layouts or Hoagie/Submarine Type Sandwiches)

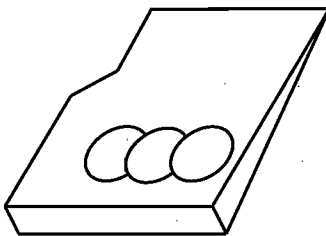

Vertical Shingles (For Rows of Large Products)

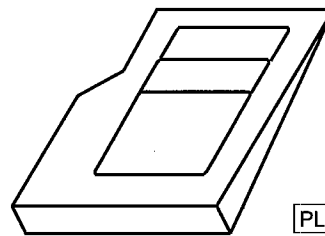

PL-50863

Fig. 18

Horizontal Shingles are for producing layouts of one, two or several rows (Fig. 19). The number of slices entered is always the number of slices per row. The maximum number of rows is nine.

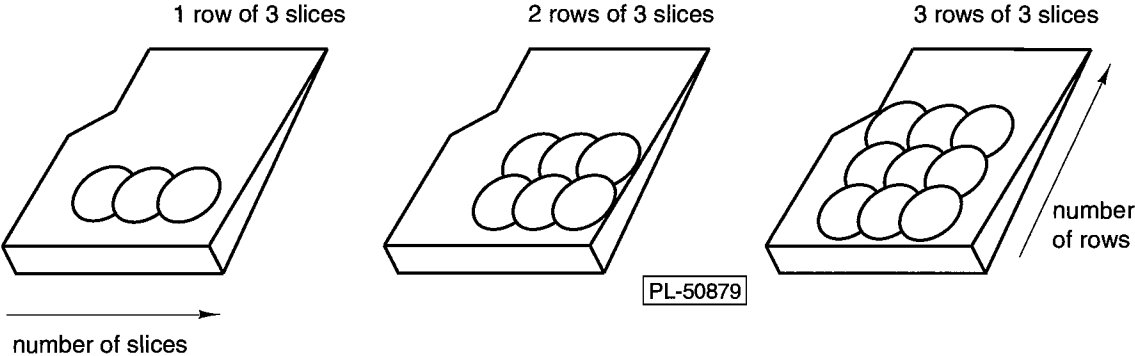

Fig. 19

Vertical Shingles are for producing layouts with any size product (Fig. 20). The number of slices entered is always the number of slices per row, in this case, per vertical row. The maximum number of rows is three (right, middle, left).

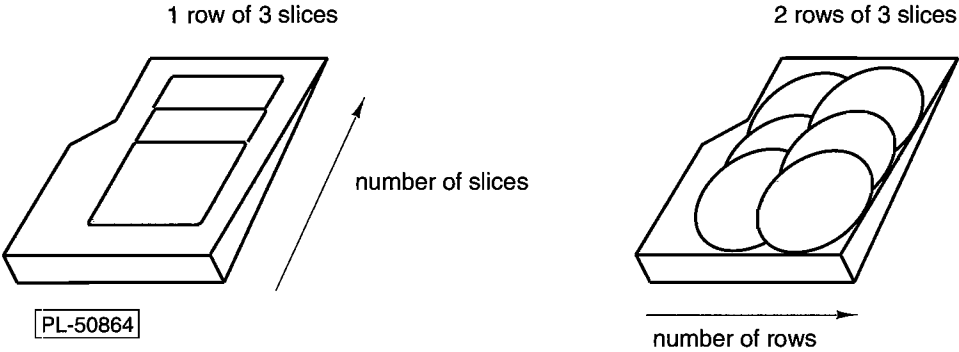

Fig. 20

THE KEYPAD (Fig. 21)

On the left are the layout selection keys with symbols denoting the four types of layouts. To select one, just press the relevant key. The LED above it will come on, confirming your selection.

On the right, there is a group of twelve keys: numerals 0 to 9 for entering the number of slices and rows, "R" the row key, and "P" the program key with small LED.

In the center are the displays for number of slices (top) and number of rows (bottom).

Preprogrammed Number of Slices

To make operation as simple as possible, your slicer has been preprogrammed for number of slices, for stacks, for horizontal and vertical rows, and for circles, so that you can use your machine as soon as it is installed. Place carriage latch in the AUTOMATIC position, then press the SLICE switch to start slicing. See REPROGRAMMING FACTORY PRESET VALUES in this manual for a listing of the factory preset values and instructions for reprogramming the preset values.

Preprogrammed Number of Rows

The number of rows for layout options of horizontal shingles and vertical shingles are also preprogrammed and may be reprogrammed if needed (see REPROGRAMMING FACTORY PRESET VALUES in this manual).

Switch-On Program

The slicer is programmed to automatically call up the preprogrammed settings as soon as you switch it on.

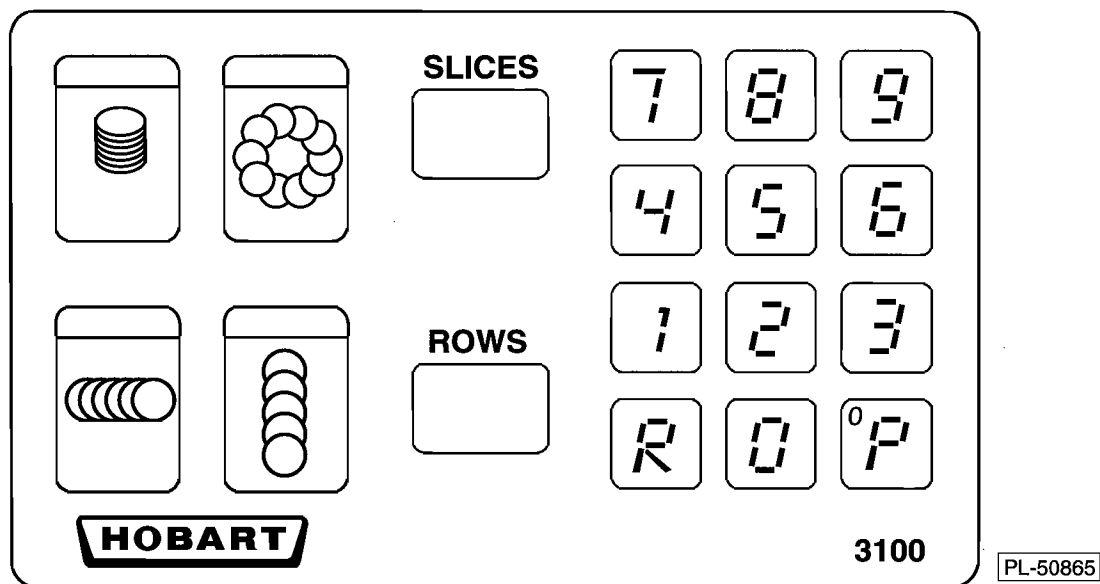

Fig. 21

BASIC LAYOUTS — RECTANGULAR TRAY

Stacks (Fig. 22)

To select this layout, press the layout selection key with the stack symbol. The LED above it will come on and number of slices preprogrammed will appear on the SLICES display.

You may change it to any number of 0 to 99 on the numeric keypad. If you enter "00", the display counts slices in ascending order. If you enter any other number, the display counts in descending order and beeps as the last slice is cut.

The stack is in the middle of the tray.

Continuous stacks: Enter "00" for number of slices and press the SLICE Switch. When you have sliced the required number of portions or reached the maximum stack height of 3¹/₈" (8 cm), press the SLICE Switch again and remove product. Press SLICE Switch again to resume program automatically.

Circular Layout (Fig. 23)

Circular layout is only possible with products up to a diameter of 4.7". The slicer will stack products larger than 4.7".

To select this layout, press the layout selection key with the circle symbol. The LED above it will come on and the preprogrammed number of slices will appear on the SLICES display. You may change it to any number from 0 to 100 (00 = 100). The number of slices is displayed in descending order.

The maximum number of slices per circle is 21. If you select a higher number, the slices will be laid on top of the first circle at the same interval as for the first 21 slices. A beep indicates that the last slice is being cut.

If you wish to change the number of slices again, press the circular layout selection key first.

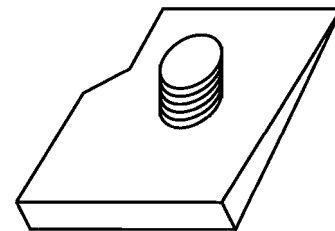
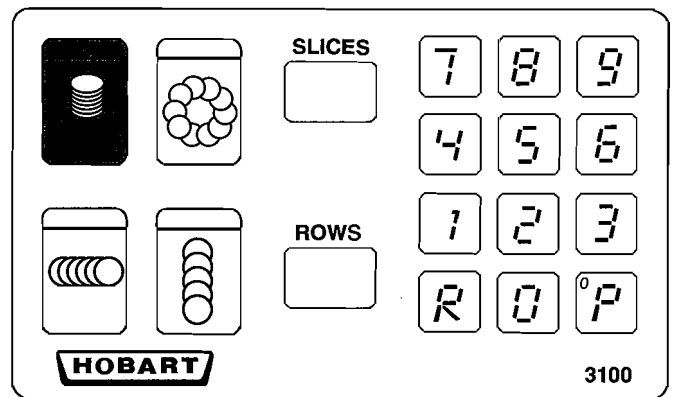

PL-50866

Fig. 22

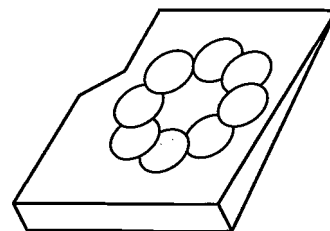
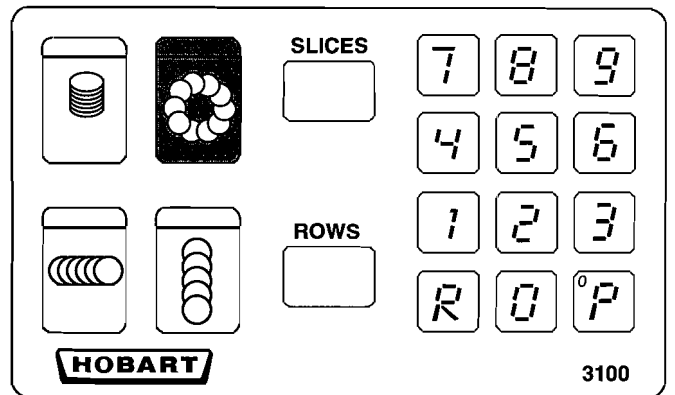

PL-50867

Fig. 23

BASIC LAYOUTS — RECTANGULAR TRAY OR CONVEYOR

Horizontal Shingles (Fig. 24)

To select this layout, press the layout selection key with the horizontal shingle symbol. The LED above it will come on. At the same time, the preprogrammed number of slices per row and the number of rows will appear on the respective displays.

Now you may change the number of slices per row to any number from 1 to 19.

You can select any number of rows from 1 to 9 (three rows and upwards cover the tray). To alter the number of rows, press Row Key "R" and "00" will appear on the display. Now enter a number from 1 to 9. The tray moves to the starting position. You can now start slicing.

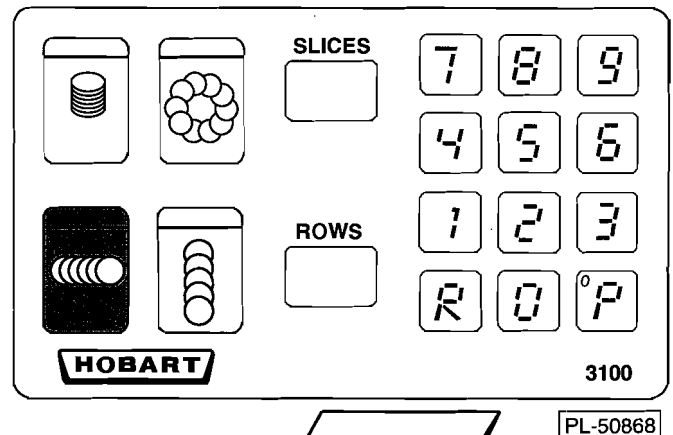

Fig. 24

Vertical Shingles (Fig. 25)

To select this layout, press the layout selection key with the vertical shingle symbol. The LED above it will come on. At the same time, the preprogrammed number of slices per row and the number of rows will appear on the respective displays. Alter the number of slices per row to any number from 1 to 19.

You have a choice of 1, 2 or 3 rows.

One Row	Down the middle of the tray
Two Rows	Left and right sides of the tray
Three Rows	Left, right and center of the tray

To alter the number of rows, press Row Key "R" and "00" will appear on the display. Now enter a number from 1 to 3. You can now start slicing.

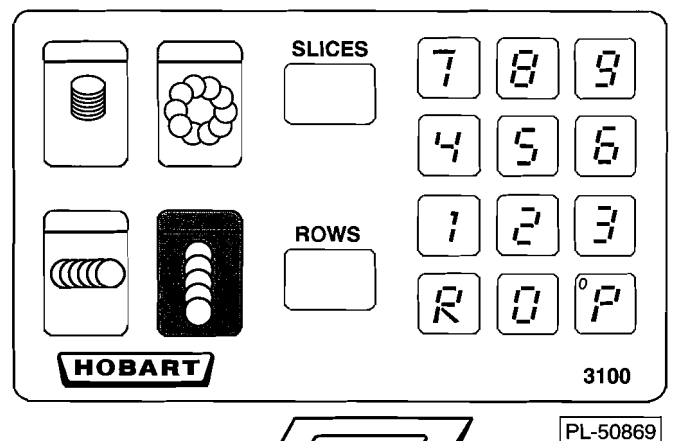

Fig. 25

MULTIPLE LAYOUTS — RECTANGULAR TRAY

Double Stacking (Fig. 26)

For two stacks, front and back, program as follows:

1. Press stack key.
2. Press row key "R".
3. Enter "2" for number of stacks.
4. Enter number of slices per stack.

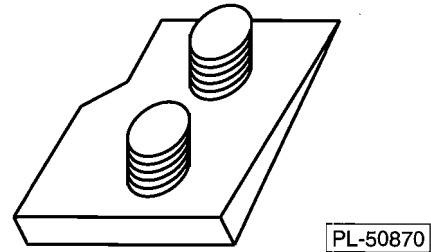

Fig. 26

Portion Stack (Fig. 27) (For repeated programs shingled)

1. Press stack key.
2. Press row key "R".
3. Enter "3" for number of stacks.
4. Enter number of slices per stack.

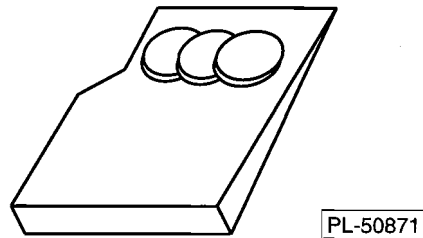

Fig. 27

The machine slices continuously. When you have sliced the required number of portions or reached the maximum height of $3\frac{1}{8}$ " (8 cm), press SLICE Switch again and remove product. Press SLICE Switch again to resume program automatically.

Circles, Horizontal Shingles, Repeated Continuously

Portions in horizontal shingles or circles can be produced repeatedly by first pressing program key "P" before selecting the layout and the number of slices and rows. When the LED on the "P" key starts to flash, program the number of rows, then the number of slices as required.

The machine slices continuously. To stop, press the SLICE Switch again.

Vertical Shingles, Repeated Continuously

A vertical shingle can be produced repeatedly by pressing program key "P" before you select the layout "vertical shingle." Press row key "R", then the corresponding number (1, 2 or 3) for the position of the row. Enter the number of slices desired for the row. (Maximum 1 row only.)

- 1 = row center
- 2 = row right
- 3 = row left

The machine slices continuously. To stop, press the SLICE Switch again.

NOTE: Horizontal and vertical shingles can also be repeated continuously on conveyor.

BASIC LAYOUTS — ROUND PLATTER

Once you have fitted the round platter, press the ON switch; the machine automatically switches to the circular layout mode. The LED on the layout selection key with the circle symbol lights up. The other three layout selection keys are not available when the round platter is in position.

The minimum number of slices the machine will produce in the circular layout is 3. If you press 1 or 2 for the number of slices in this mode, the machine will still do 3 slices.

If you press the SLICE Switch before the programmed number of slices is finished, the machine will stop. When you press the SLICE Switch again, the machine will begin where it left off in the number of slices programmed.

With the round platter, you have the option of slicing 3 different diameter circles or slicing all 3 diameters consecutively. You can also slice 3 different diameter half-circles (see HALF-CIRCLE on page 20).

When you want to consecutively slice product (full circle) in the outer, middle and inner circle, the machine will stop after the outer circle is completed. To continue to the middle circle, press the SLICE Switch. When the middle circle is completed, press the SLICE Switch to begin slicing the inner circle.

Outer Circle (Fig. 28)

For a full outer circle, press row key "R" and then enter the number "3".

Enter the number of slices. If you enter "00", the slices will be deposited continuously on the outer circle only, with the smallest interval between slices. The number of slices is displayed in ascending order. If you enter a number from 1 to 32, the machine will stop after the preselected number of slices and switch to the middle circle. Enter a new number of slices, if required, and restart the carriage. (The layout sequence for 3 full circles is outer, then middle, then inner.)

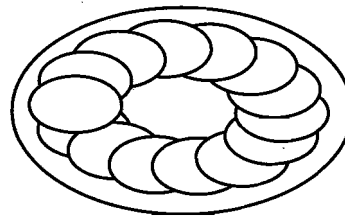

PL-50872

Fig. 28

Middle Circle (Fig. 29)

For a full middle circle, press row key "R" and then enter the number "2".

Enter the number of slices. If you enter "00", the slices will be deposited continuously with the smallest interval between slices on the middle circle only. The number of slices is displayed in ascending order. If you enter a number from 1 to 32, the machine will stop after the preselected number of slices and switch to the inner circle. Enter a new number of slices, if required, and restart the carriage. (The layout sequence for 2 full circles is middle, then inner.)

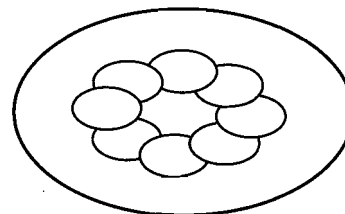

PL-50873

Fig. 29

Inner Circle (Fig. 30)

For a full inner circle, press row key "R" and then enter the number "1".

Enter the number of slices. If you enter "00", slices will be deposited continuously on the inner circle with the smallest interval between them. If you enter a number from 1 to 32, the machine will stop after the preselected number of slices. (No circle sequence.)

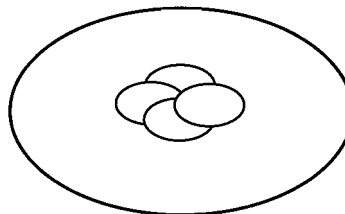

PL-50874

Fig. 30

Half-Circle

To slice an outer half-circle, press row key "R" and then enter the number "6".

To slice a middle half-circle, press row key "R" and then enter the number "5".

To slice an inner half-circle, press row key "R" and then enter the number "4".

After selecting the row key and corresponding number for the outer, middle or inner circle, enter the number of slices. If you enter a number from 3 to 32, the machine will stop after the preselected number of slices. For best results, select a number of slices 16 or less to get a true half-circle. Depending upon your product size, you may need to select fewer slices than 16. Selecting 16-32 slices generally results in a half to a full circle.

The machine will not automatically sequence to the next row, as it does when slicing full circles. You must press the row key "R" again and then enter one of the numbers above for the next row. Enter a new number of slices if desired.

MULTIPLE LAYOUTS — ROUND PLATTER

If you want full circles of a particular number of slices from 3 to 32 to be deposited repeatedly on one part of the platter only (without circle sequence), press program key "P" before you select the circle. Now press row key "R", followed by the corresponding number (1, 2 or 3).

- 1 = repeated inner circle with number of slices from 3 to 32
- 2 = repeated middle circle with number of slices from 3 to 32
- 3 = repeated outer circle with number of slices from 3 to 32

The machine will stop after slicing the programmed number of slices. To continue slicing the same number of slices in the same circle, press the SLICE Switch again. To stop slicing at any time, press the SLICE Switch.

SANDWICH PACKAGE LAYOUTS

The sandwich package includes special software and a depositor that enables you to build meat and cheese sandwich portions on the slicer. Meat and cheese are placed on the carriage together. The diameter of these two products to be sliced together should be about equal.

Measure the diameter of the second product (product that will be at the back of the carriage). The second product will be the slice on the bottom.

1. Fit sandwich depositor on slicer.
2. Place products on carriage.
3. Press program key "P" (starts flashing).
4. Enter the number "9" (flashes 3 times). (This step activates the sandwich layout mode.) The diameter currently programmed will appear in the SLICES display. To keep this same diameter, press the program key "P" again.
5. To change the diameter, enter the second product's diameter in tenths of inches. (**NOTE:** The display does not have a decimal point. To select, for example, 3.5 inches, enter "35"). Press program key "P".
6. If you want to slice continuous portions, press the program key "P" again.
7. Press Stack key.
8. Enter number of slices.
9. Press row key "R" and enter the number "4". (This step finalizes the sandwich layout mode.)

If the slice of the first product is not deposited directly on top of the second product, but more on the right side, increase diameter setting from Step 5 above by +04" (four-tenths), following Steps 3-9 above. If the slice of the first product is more left than the second, reduce diameter setting from Step 5 above by -04" (four-tenths), following Steps 3-9 above. Repeat procedure if necessary.

Model 3100C Only — If the conveyor is being used and the slicer is not able to slice correctly with 60 strokes per minute because of the time needed to deposit 2 slices, reduce speed to 40 strokes per minute.

EXAMPLES

Stacks (Fig. 31)

For a stack of 6 slices:

1. Press stack key.
2. Enter 6.

The machine beeps as the last slice is cut.

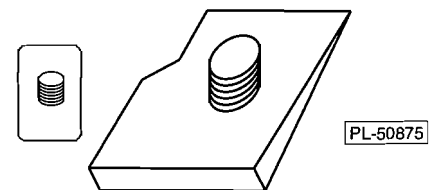

Fig. 31

Circular Layout (Fig. 32)

1. Select circular layout.
2. Enter 8 for the number of slices.

If you want to alter the number of slices, press circular layout key again first.

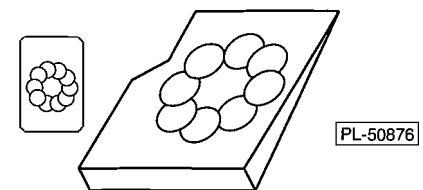

Fig. 32

Horizontal Shingles (Fig. 33)

For a layout of two horizontal shingles of 8 slices each:

1. Select rows across.
2. Press row key "R".
3. Enter "2" for number of rows.
4. Enter "8" for number of slices per row.

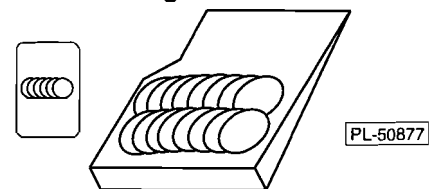

Fig. 33

Vertical Shingles (Fig. 34)

For a layout of two vertical shingles of 16 slices each:

1. Select rows down.
2. Press row key "R".
3. Enter "2" for number of rows.
4. Enter "16" for number of slices per row.

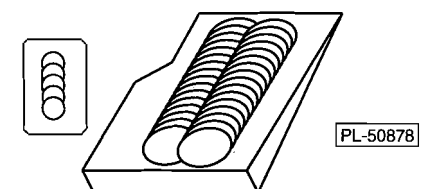

Fig. 34

SLICING (See Fig's. 35 & 36 for Slicer Components)

Sensors (See Fig. 42) determine the diameter of the product to be sliced so that, even if the slices are of varying sizes, all stacks' edges will be aligned. For this reason, always ensure the sensors and the inside edge of the carriage are kept clean.

The transport system carries product from the knife to the depositor. It should be installed on the slicer at all times during use. The slicing, sandwich and chipping/shaving depositors pull slices off the transport system and deposit them on the tray. Only one depositor may be used at a time. The sandwich depositor may be used to slice two different products side by side at the same time (i.e., meat and cheese), depositing a slice of the product at the back of the carriage on the tray first and then a slice of the product at the front of the carriage on top of the first slice.

When slicing long product, the slicer will stop automatically when the meat grip arm assembly nears the gauge plate. To continue slicing, follow the RECLAMPING instructions in this manual.

Manual Operation

1. Place carriage latch in MANUAL position.
2. Unlock meat grip arm assembly from drive latch and slide over to the right.
3. Lift upper meat grip by squeezing the grip latch and meat grip handle.
4. Place product on lower meat grip with part to be sliced projecting from under the upper meat grip to the left towards the knife.
5. Close upper meat grip and press down lightly to clamp product into place.
6. Push meat grip arm assembly with product up against gauge plate.
7. Slide fence down to product and press lightly.
8. Press ON switch. Keyboard lights are on.
9. Select pattern.
10. Set slice thickness. The numbers on the slice thickness control do not indicate actual measurements, but may be used for reference to duplicate slice thicknesses. Do not attempt to slice beyond "8" on the slice thickness control knob.
11. Press SLICE switch to start knife. **WARNING: KNIFE WILL ROTATE.** The knife shuts off if the carriage is not moved after 10 seconds. To restart knife, press SLICE switch.
12. Place hand on meat grip handle and move the carriage forward and backward to slice. (There is no need to push product in toward the knife; the product will be fed automatically even in manual mode.)
13. The machine will beep at the end of the program.
14. Turn machine OFF.

15. Close gauge plate (mark past zero).
16. Slide meat grip arm assembly over to right with drive latch.
17. Lift upper meat grip (squeeze grip latch and meat grip handle) and remove product.
18. Lower upper meat grip again.

Automatic Operation

1. Place carriage latch in the AUTOMATIC position. Pull carriage forward until you hear the latch fall into place.
2. Unlock meat grip arm assembly from drive latch and slide over to right.
3. Lift upper meat grip by squeezing the grip latch and meat grip handle.
4. Place product on lower meat grip with part to be sliced projecting from under the upper meat grip to the left towards the knife.
5. Close upper meat grip and press down lightly to clamp product into place.
6. Push meat grip arm assembly with product up against gauge plate.
7. Slide fence down to product and press lightly.
8. Press ON switch. Keyboard lights are on.
9. Select pattern.
10. Set slice thickness. The numbers on the slice thickness control do not indicate actual measurements, but may be used for reference to duplicate slice thicknesses. Do not attempt to slice beyond "8" on the slice thickness control knob.
11. Press SLICE switch. **WARNING: KNIFE WILL ROTATE AND CARRIAGE WILL MOVE.**
12. At end of program, the carriage will stop and the knife will shut off. The machine will also stop itself and shut the knife off when product is finished or nears the gauge plate (see RECLAMPING). If you want to continue the program after reclamping, press SLICE switch again.
13. Turn machine OFF.
14. Close gauge plate (mark past zero).
15. Slide meat grip arm assembly over to right with drive latch.
16. Lift upper meat grip (squeeze grip latch and meat grip handle) and remove product.
17. Lower upper meat grip again.

RECLAMPING

1. Close gauge plate.
2. Slide meat grip arm assembly and product over to right with drive latch.
3. Unclamp upper meat grip with grip latch and meat grip handle.
4. Remove product, replace and reclamp with part to be sliced projecting out to the left, below upper meat grip and above lower meat grip, towards gauge plate.
5. Proceed as for AUTOMATIC OPERATION above.

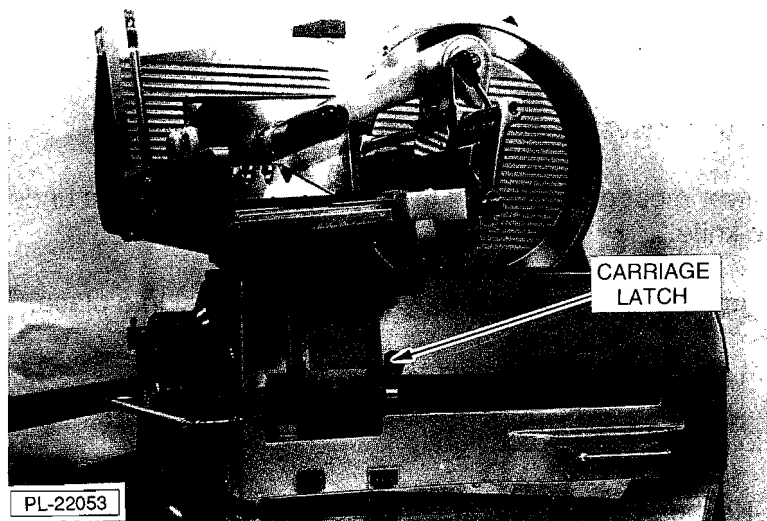

Fig. 35

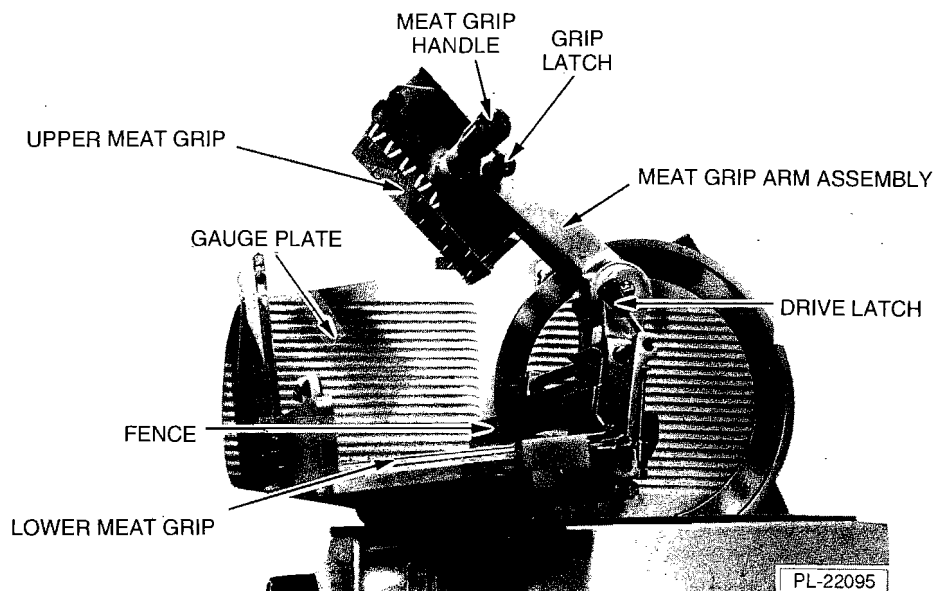

Fig. 36

REPROGRAMMING FACTORY PRESET VALUES

Factory preset values are:

Stacks	—	1 stack (middle of platter), 10 slices.			
Circular	—	1 circle, 21 slices (only for products with 4.7" diameter).			
Horizontal Shingle	—	5 rows, 6 slices.			
Vertical Shingle	—	2 rows, 8 slices.			
Round Platter	—	Outer Full Circle (R3) = 15 slices.	Outer Half-Circle (R6) = 15 slices.		
		Middle Full Circle (R2) = 8 slices.	Middle Half-Circle (R5) = 8 slices.		
		Inner Full Circle (R1) = 3 slices.	Inner Half-Circle (R4) = 3 slices.		

To Program Rectangular Platter or Conveyor

1. Turn slicer on.
2. Press "P" key.
3. Enter "0" four times.

The "Slices" keyboard display will flash "01" three times.
4. Select a switch-on program.

This is the layout pattern that will be displayed when the slicer is first turned on. Select by pressing the desired pattern, then press "P".

The "slices" display will flash "02", then display the number that is currently programmed.
5. Select "Horizontal Shingles".

This is the number of rows which will be displayed horizontally across the tray with preprogrammed patterns. Enter desired number of rows from 1-9 and press "P" key.

The "slices" display will flash "03", then display the number that is currently programmed.
6. Set stack correction value. (Applicable to rectangular tray only.)

This is the amount the tray travels during stacking to ensure even stacks. This value is normally preset at the factory and does not require changing. However, if stack's edges are not aligned, the value may be changed in a range from 2-15, with 2 = minimum correction step, and 15 = maximum correction step. Press "P" key after entering new value, or to accept the preset value.

The "slices" display will flash "04", then display the number that is currently programmed.
7. Set width for horizontal shingles (Fig. 37).

This is width in inches that pattern will extend across tray. A width up to 8.8" (22 cm) can be entered. To enter 8.8", for example, press "88" (no decimal point). Press "P" key after entering or to accept the preset value.

The "slices" display will flash "05", then display the number that is currently programmed. No decimal point will show in the display.

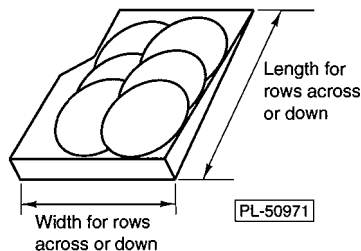

Fig. 37

8. Set length for horizontal shingles (Fig. 37).

This is length in inches that pattern will extend down tray. A length up to 8.4" (21 cm) can be entered. To enter 8.4", for example, press "84" (no decimal point). Press "P" key after entering or to accept the preset value.

The "slices" display will flash "06", then display the number that is currently programmed. No decimal point will show in the display.

9. Set width for vertical shingles (Fig. 37).

This is width in inches that pattern will extend across tray. A width up to 8.8" (22 cm) can be entered. To enter 8.8", for example, press "88" (no decimal point). Press "P" key after entering or to accept the preset value.

The "slices" display will flash "07", then display the number that is currently programmed. No decimal point will show in the display.

10. Set length for vertical shingles (Fig. 37).

This is length in inches that pattern will extend down tray. A length up to 5.6" (17 cm) can be entered. To enter 5.6", for example, press "56" (no decimal point). Press "P" key after entering or to accept the preset value.

The "slices" display will flash "08", then display the number that is currently programmed. No decimal point will show in the display.

11. Select number of rows down tray.

This is the number of rows which will be displayed down the tray (front to back) with the preprogrammed patterns. Enter desired number of rows and press "P" key.

The display will flash "00".

12. Select number of slices.

The number of slices most frequently used with each layout pattern can now be entered. Select a layout pattern (e.g., stacking) and enter the desired number of slices. Press the "P" key. Repeat for each pattern.

The display will flash "00" after each selection.

13. To store programming, set carriage to manual and push the carriage forward as far as it will go. The display should indicate the new switch-on program.

To Program Round Platter

1. Fit round platter to slicer and turn slicer on.
2. Press "P" key. Enter "0" four times. **The keyboard display will flash "05" three times.**
4. Select switch-on circle. Press 3, 2, or 1 for outer, middle or inner circle. Press "P" key.
The display will flash "00".
5. Select number of slices. For each full circle, press "R", enter 3, 2, or 1; for each half-circle, press "R", enter 6, 5, or 4. Then enter desired number of slices and press "P" key.
The display will flash "00" after each selection.
6. To store round platter programming, set carriage to manual and push the carriage forward as far as it will go. The display should indicate the new switch-on program.

CLEANING

WARNING: TURN MACHINE OFF AND DISCONNECT THE POWER CORD BEFORE CLEANING THE SLICER.

WARNING: THE SLICING KNIFE IS VERY SHARP. USE EXTREME CAUTION WHEN WORKING NEAR THE KNIFE.

This machine **MUST** be thoroughly cleaned and sanitized after each day's operation or anytime it is not to be used for an extended period of time. **Do not use steam or hose down.** Do not use abrasive cleaners. Use a mild soap (such as Spic and Span) and hot water solution and a clean cloth. Wipe all surfaces of the machine, then rinse, using another clean cloth and fresh water. Use only products formulated to be safe on stainless steel or aluminum. **DO NOT** wash any slicer components in a dishwasher.

Do not exceed chemical manufacturer's recommended concentrations for detergent or sanitizer. Do not exceed 200 parts per million concentration of available chlorine. For example, mixing 1 tablespoon of 5.25% sodium hypochlorite bleach with 1 gallon of water yields a solution containing 200 ppm of available chlorine. Solution with concentrations greater than 200 ppm will accelerate corrosion of metals. Maximum exposure to sanitizing solution varies with temperature and concentration. Rinse with clean water.

1. Turn slice thickness control clockwise as far as it will go (past zero).
2. Take off the tray, round platter, or conveyor assembly.
3. Remove depositor by unscrewing the knob (Fig. 38). The knob does not come off.
4. Remove transport system by lifting straight up.
5. Remove plastic scrap collector under knife by sliding back.

6. Remove fence, lower meat grip and upper meat grip in that order (Fig. 39).

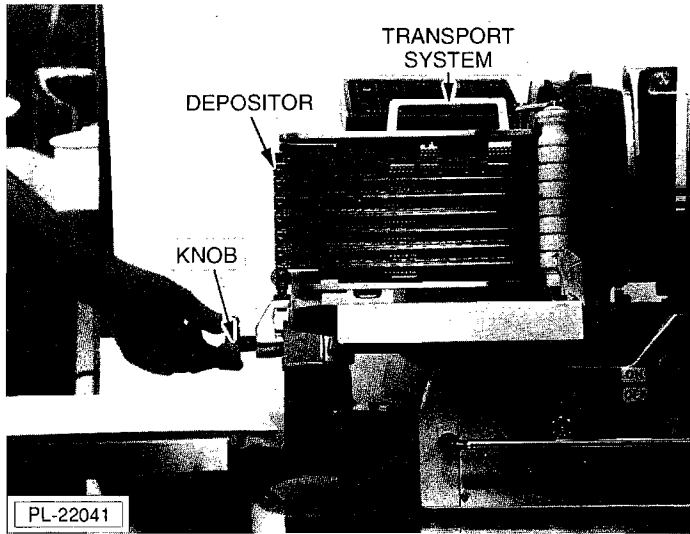

Fig. 38

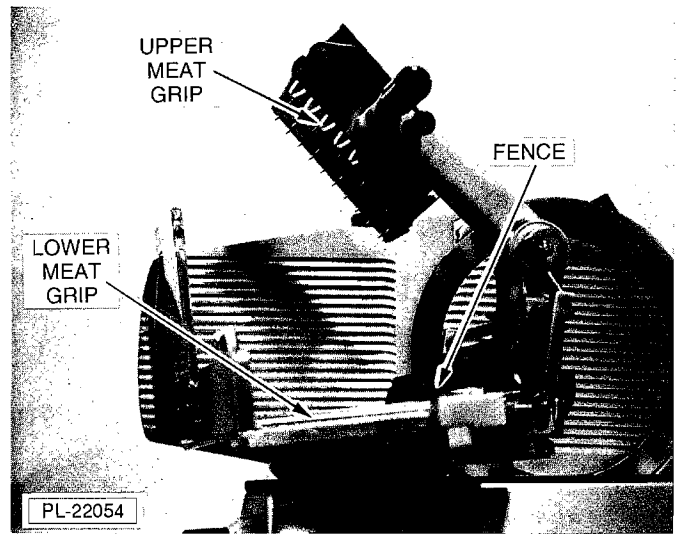

Fig. 39

7. Tilt the carriage. To do this, place carriage latch in MANUAL position. Keeping your left hand on the front of the machine housing, hold the front of the carriage with your right hand and pull the carriage toward you until it will go no farther. Then tilt it over to the right. As long as the carriage is tilted, the gauge plate is locked and cannot be opened accidentally while cleaning.

8. Unscrew knife cover lock knob (Fig. 40) and remove knife cover (Fig. 41).

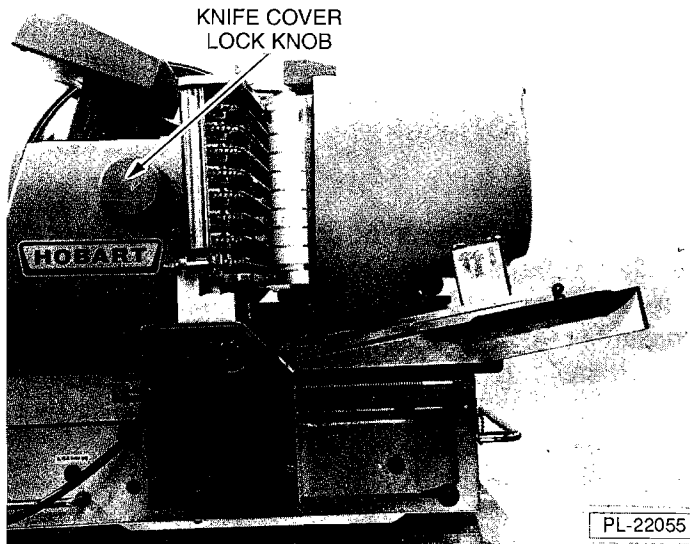

Fig. 40

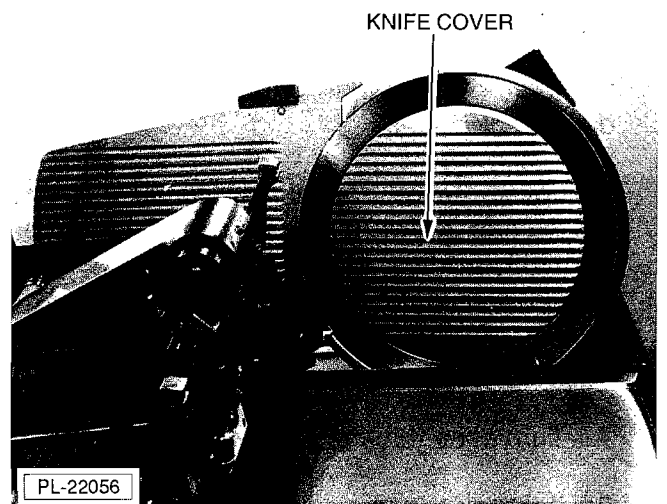

Fig. 41

9. Clean the machine and parts with warm water and detergent. Use the large brush (supplied) to clean the transport. Always brush the transport system in the direction of drive. Use care not to bend spikes. Use the long brush (supplied) to clean between the knife and the motor housing.
10. Clean sensors (Fig. 42) with a damp cloth.
11. With gauge plate (Fig. 42) closed, CAREFULLY clean knife. Wipe outward from the center. Never use steel pads to clean the knife.

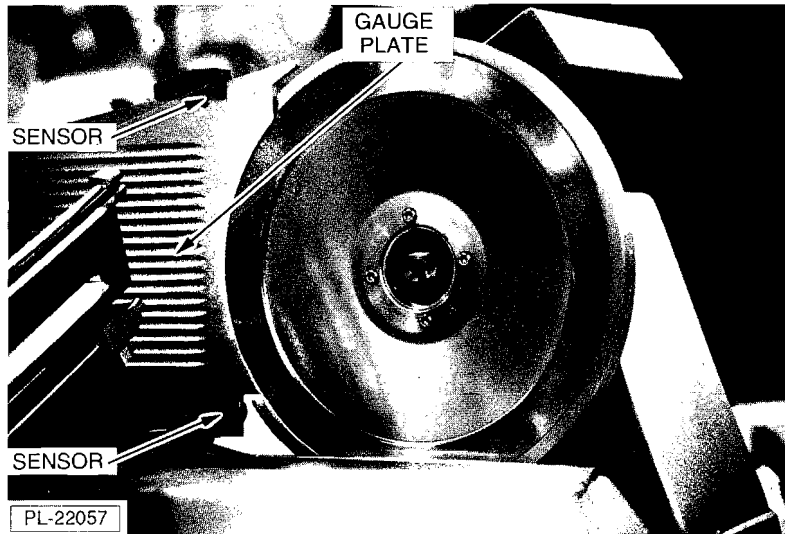

Fig. 42

12. Clean ring guard. Soak a thin cloth in a detergent/hot-water solution. Insert a corner of the cloth at the bottom part of the ring guard where it meets the gauge plate (Fig. 43). Place right hand on right side of gauge plate and left hand on left side of gauge plate. While holding cloth with both hands, and still using just a corner of the cloth, work it between the knife and ring guard. Pull the cloth completely around the ring guard (Fig. 44). Do not let cloth wad up as you move it around the ring guard. Repeat this procedure if needed.



Fig. 43



Fig. 44

13. Rinse or wipe with clean water.
14. Reassemble in reverse order of disassembly.
 - a. Replace knife cover (the knife cover only goes on the shaft one way). The pin on the back of the knife cover fits into the slot on the shaft. The knife cover must be flush against the knife with no gaps. Tap on the cover to locate.
 - b. To bring carriage back to the upright position, tilt it back up.
 - c. Mount scrap collector under knife.
 - d. Transport system MUST lock in properly.
 - e. Mount depositor in an upright position.
 - f. Round platter MUST lock in properly.
 - g. Tray guide must engage properly.

NOTE: Failure to follow use, care, and maintenance instructions may void your Hobart warranty.

MAINTENANCE

WARNING: THE SLICING KNIFE IS VERY SHARP. USE EXTREME CAUTION WHEN WORKING NEAR THE KNIFE.

SHARPENING THE KNIFE

WARNING: UNPLUG POWER CORD.

Read the following instructions carefully. They MUST be carried out in the order given.

Preparation

1. Press main OFF switch.
2. The knife must be free from grease or other food residue. Clean knife following the procedure outlined in CLEANING in this manual.
3. Remove depositor, transport system and tray, round platter, or conveyor.
4. Unlock meat grip arm assembly with drive latch and slide over to right.
5. Place carriage latch in MANUAL position.

Mount Sharpener (Fig's. 45 and 46)

1. Pull carriage all the way toward you.
2. Turn red knob on sharpener to OFF.
3. Set gauge plate to sharpening position. **WARNING:** KNIFE IS NOW UNPROTECTED.
4. Fit sharpener onto carriage with open side against gauge plate and top and bottom guides in the gap between gauge plate and carriage.

5. Close gauge plate slightly until sharpener touches gauge plate.
6. Push carriage forward until top of sharpener (Fig's. 45 and 46) fits into the slot in the ring guard (Fig's. 45 and 46). The knife is now protected again for the sharpening process to follow.

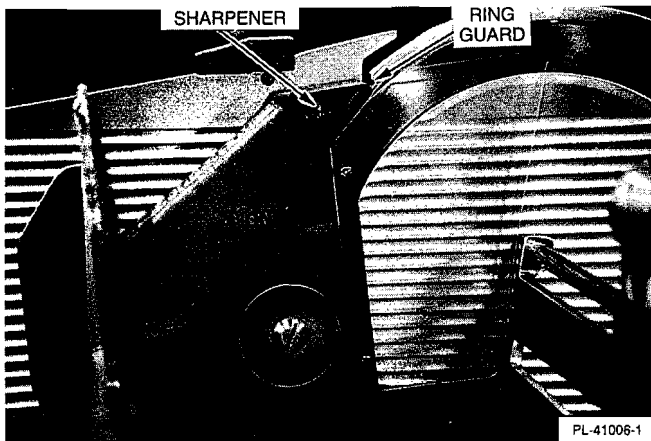

Fig. 45
(Sharpener manufactured prior to May, 1997.)

Sharpening (Fig. 45)

1. Press main ON switch (green).
2. Set red knob on sharpener to ON.
3. Press SLICE switch. Knife will run for 10 seconds. If necessary, repeat sharpening by pressing SLICE switch again.
4. Set knob on sharpener to OFF.
5. Press main OFF switch (red).
6. Wait until knife comes to a stop, then pull carriage back again and remove sharpener. Close gauge plate.
7. Clean knife following instructions in the CLEANING section of this manual.
8. Mount transport system, depositor and tray.
9. Wipe slicer with a clean damp cloth to remove any grinding particles.

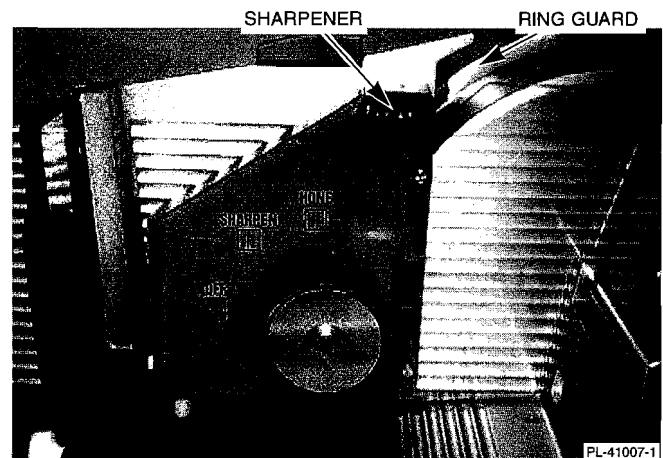

Fig. 46
(Sharpener manufactured beginning May, 1997.)

Sharpening (Fig. 46)

1. Press main ON switch (green).
2. Set red knob on sharpener to SHARPEN.
3. Press SLICE switch. Knife will run for 10 seconds. If necessary, repeat sharpening by pressing SLICE switch again.
4. Turn sharpener to HONE. Press SLICE switch to start knife.
5. Hone for 5 seconds.
6. Set knob on sharpener to OFF.
7. Press main OFF switch (red).
8. Wait until knife comes to a stop, then pull carriage back again and remove sharpener. Close gauge plate.
9. Clean knife following instructions in the CLEANING section of this manual.
10. Mount transport system, depositor and tray.
11. Wipe slicer with a clean damp cloth to remove any grinding particles.

LAYOUT PROBLEMS

Stacks and Vertical Shingles

If the machine produces a layout on the right-hand side of the tray only, clean the sensors and the inside edge of the carriage first.

Horizontal Shingles

If the machine deposits one slice per row on the right-hand side of the tray, clean the sensors and the inside edge of the carriage first.

Circular Layout on the Rectangle Tray

If the machine produces stacks, the diameter of the product must be almost or greater than 4½" (12 cm). Clean the sensors and the inside edge of the carriage first, and choose a smaller product.

LUBRICATION

After Every Cleaning: Place one drop of lubricant (supplied) on guide rods (Fig. 47).

Monthly: Place 3 drops of lubricant in the lube port (Fig. 47).

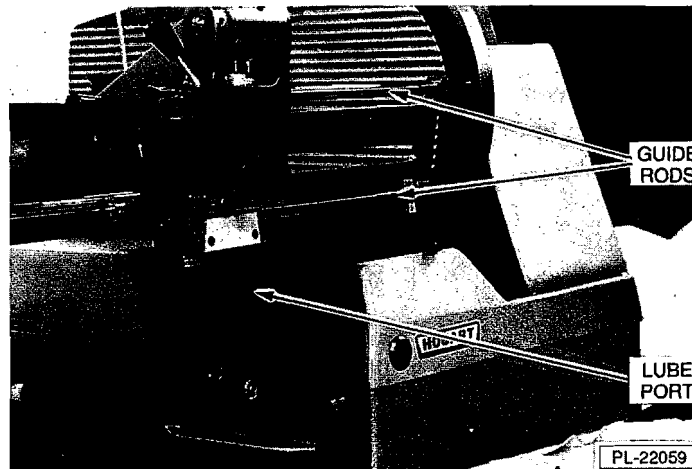

Fig. 47

WEAR ADJUSTMENT

After many sharpenings of the knife, it may become necessary to have the gauge plate adjusted closer to the knife. This must be done by an authorized Hobart Service Technician.