

REV	DATE	BY	DESCRIPTION	ECO #
D	2-14-2022	MAS	120V REPLACE 10347 CIRCUIT BREAKER WITH 10348, 220V REPLACE 47487 WITH 10347, ADD 84798 RESISTOR FOR 120V	

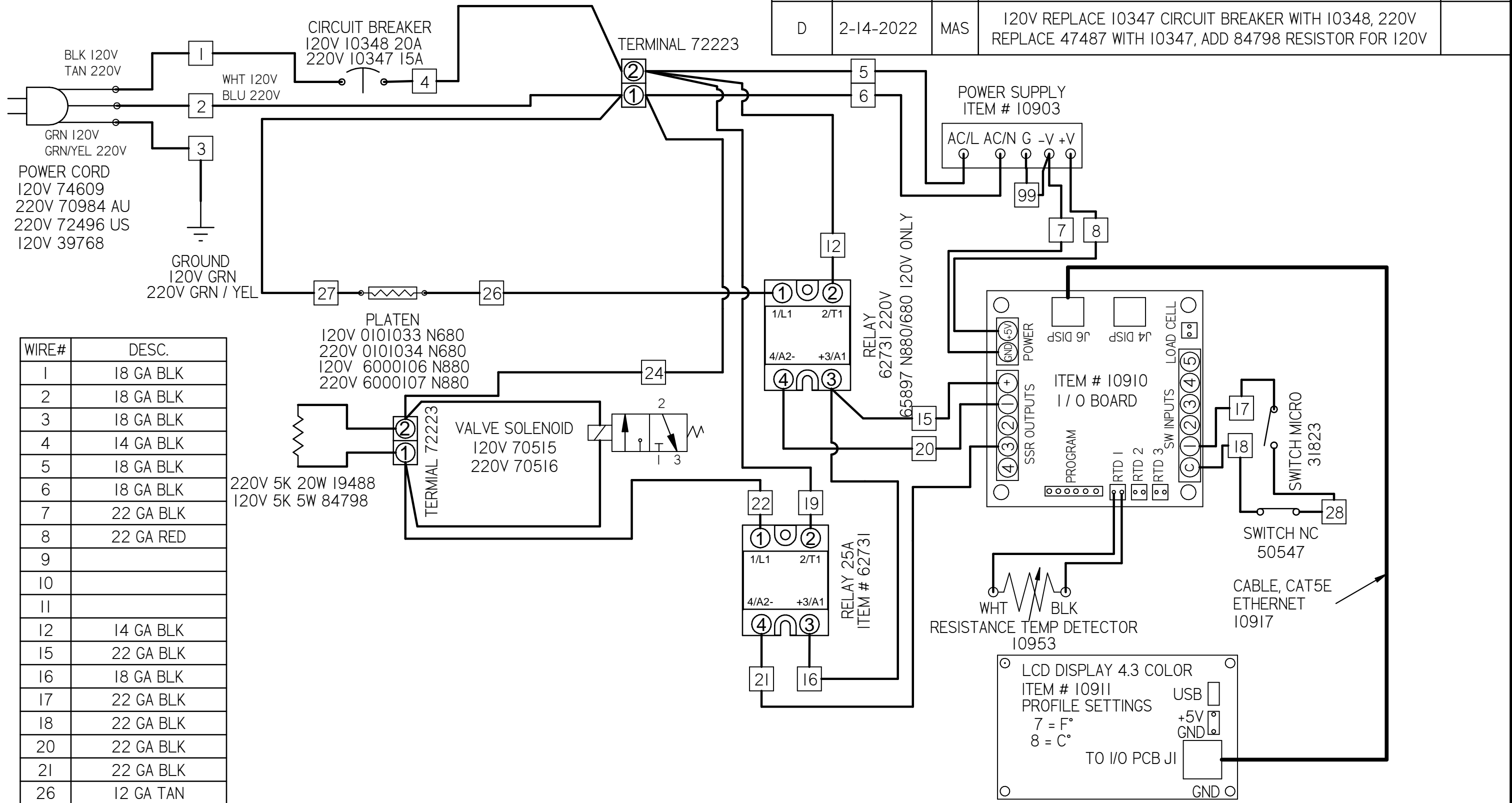

WIRE#	DESC.
1	18 GA BLK
2	18 GA BLK
3	18 GA BLK
4	14 GA BLK
5	18 GA BLK
6	18 GA BLK
7	22 GA BLK
8	22 GA RED
9	
10	
11	
12	14 GA BLK
15	22 GA BLK
16	18 GA BLK
17	22 GA BLK
18	22 GA BLK
20	22 GA BLK
21	22 GA BLK
26	12 GA TAN
27	12 GA TAN
28	22 GA BLK
99	22 GA BLK

HIX Corporation 1201 E 27th Terrace, Pittsburg, KS 66762 Phone (620) 231-8568 Fax (620) 231-1598 Email: mail@hixcorp.com www.hixcorp.com <small>This document and the information contained herein is the sole property of HIX Corporation. It will be held confidentially and may not be disclosed to third parties for any reason without prior written consent of HIX Corporation (Copyright 2005)</small>		TITLE WIRING DIAGRAM N680, N880 120/220V US, AU 4.3" LCD	
Tolerance Unless Noted 0 +/- .060 .00 +/- .030 .000 +/- .010 FRACTION +/- 1/32 ANGLES +/- 1 DEGREE		Drawn MSCHULTZ Checked Date 7-29-2020	DWG NO 8806009 REV D Project N-680 / N-880 4.3" CLCD SIZE B SHEET 1 OF 1

REV	DATE	BY	DESCRIPTION	ECO #
B	1-31-2022	MAS	CHANGED CIRCUIT BREAKERS - 10347 TO 10348, 47487 TO 10347	

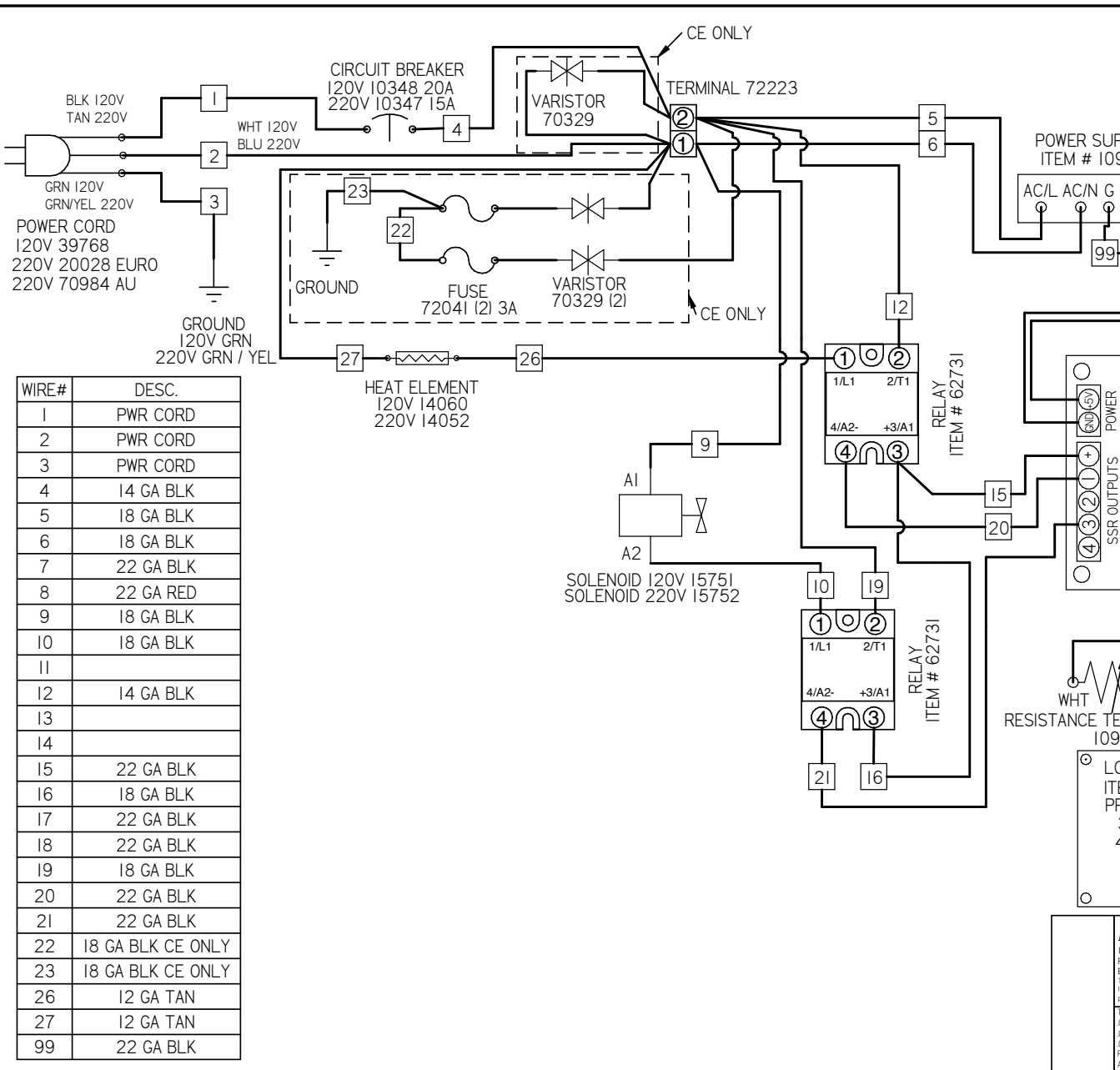

WIRE#	DESC.
1	PWR CORD
2	PWR CORD
3	PWR CORD
4	14 GA BLK
5	18 GA BLK
6	18 GA BLK
7	22 GA BLK
8	22 GA RED
9	18 GA BLK
10	18 GA BLK
11	
12	14 GA BLK
13	
14	
15	22 GA BLK
16	18 GA BLK
17	22 GA BLK
18	22 GA BLK
19	18 GA BLK
20	22 GA BLK
21	22 GA BLK
22	18 GA BLK CE ONLY
23	18 GA BLK CE ONLY
26	12 GA TAN
27	12 GA TAN
99	22 GA BLK

HIX Corporation 1201 E 27th Terrace, Pittsburg, KS 66762 Phone (620) 231-8568 Fax (620) 231-1598 Email: mail@hixcorp.com www.hixcorp.com <small>This document and the information contained herein is the sole property of HIX Corporation. It will be held confidentially and may not be disclosed to third parties for any reason without prior written consent of HIX Corporation (Copyright 2005)</small>		TITLE WIRING DIAGRAM S450, S650 120/220V 4.3" LCD	
DWG NO 6010060		REV B	
Project S-450 / S-650 4.3" CLCD		Project S-450 / S-650 4.3" CLCD	
SIZE B		SHEET 1 OF 1	

Tolerance Unless Noted	Drawn	Date
0 -/- .060	MSCHULTZ	5-22-2019
.00 -/- .030	Checked	Date
.000 -/- .010		
FRACTION -/- 1/32		
ANGLES -/- 1 DEGREE		

DO NOT SCALE

