

OPERATOR'S MANUAL

DXM-1620

Manual Cold Meat Press

doughXpress.

HIX® CORPORATION COMMERCIAL FOOD DIVISION



DXM-1620W



DXM-1620SS

For Customer Service:
Call 1-800-835-0606 or Visit hixcorp.com

HIX CORPORATION



CONTENTS

<i>Receiving & Setup</i>	3
<i>Operation</i>	3
<i>Cleaning & Maintenance</i>	3
<i>Parts List</i>	4
<i>Warranty</i>	8

BEFORE warranty repair you MUST get Prior Authorization



RECEIVING & SETUP

UNPACKING

Remember to save all packing materials - including any crating, boxes, liners, and boards. You may need these for shipping your machine or should a repair be necessary in the future.

INSPECTION

Inspect your machine for hidden shipping damage. Contact the delivery company immediately, should you find damage.

PLATEN SURFACE

Slight surface imperfections are a normal part of the aluminum casting process for the platens on your press. These are not considered a defect and do not affect the functionality of the machine in any way.

OPERATION

INSTALLATION

Remove from box (keep box just in case your need to return). Team lift, as the machine is very heavy.

1. With the press in the open position, adjust the press to the desired thickness by turning the control knob located on the top of the machine. Thickness is reduced by turning the knob **clockwise** and increased by turning it **counterclockwise**, as indicated. Using the thickness control knob, turn right for thinner or left for thicker until you have the thickness you desire.
CAUTION: DO NOT OPERATE THIS PRESS WITH ANY OTHER PERSON(S) / HAND(S) NEAR YOU OR THE PRESS. SERIOUS INJURY COULD RESULT.
2. Pull the handle down all the way, applying pressure, until it stops. Raise the handle all the way up.
3. Rotate the lower platen out and remove your flattened product.

CLEANING & MAINTENANCE

CLEANING THE PLATENS

1. Open the platen for easier access.
2. Clean the platens with with a mild soap and warm water applied with a soft cloth or sponge. Do not use steel wool, scrub sponges, kitchen or oven cleaners, or any other kind of abrasive material. This will damage the coating
3. Wipe clean with a dry cloth.

CLEANING THE OUTSIDE SURFACES OF THE MACHINE

Use a mild soap and warm water applied with a soft cloth or sponge. Do not use steel wool, scrub sponges, kitchen or oven cleaners, or other abrasives that will damage the painted surface.

LUBRICATION

Your press requires lubrication every 15,000 cycles or every 6 months. Use NSF/NLGI 2 rated food grade grease (such as Bel-Ray No-Tox #2 or equivalent). Lubricate all moving or hinged points.

REPLACEMENT PARTS LIST (DXM-1620W MODEL)

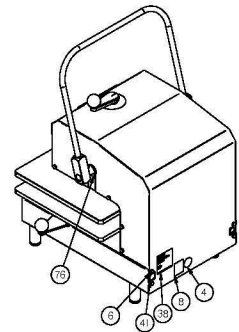
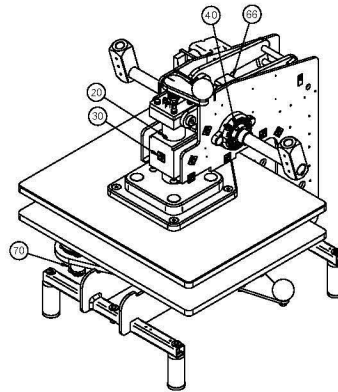
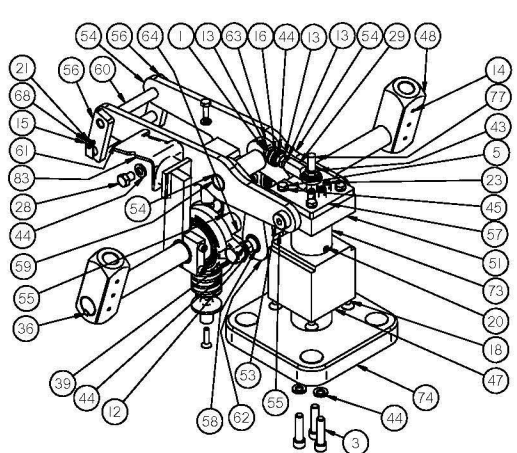
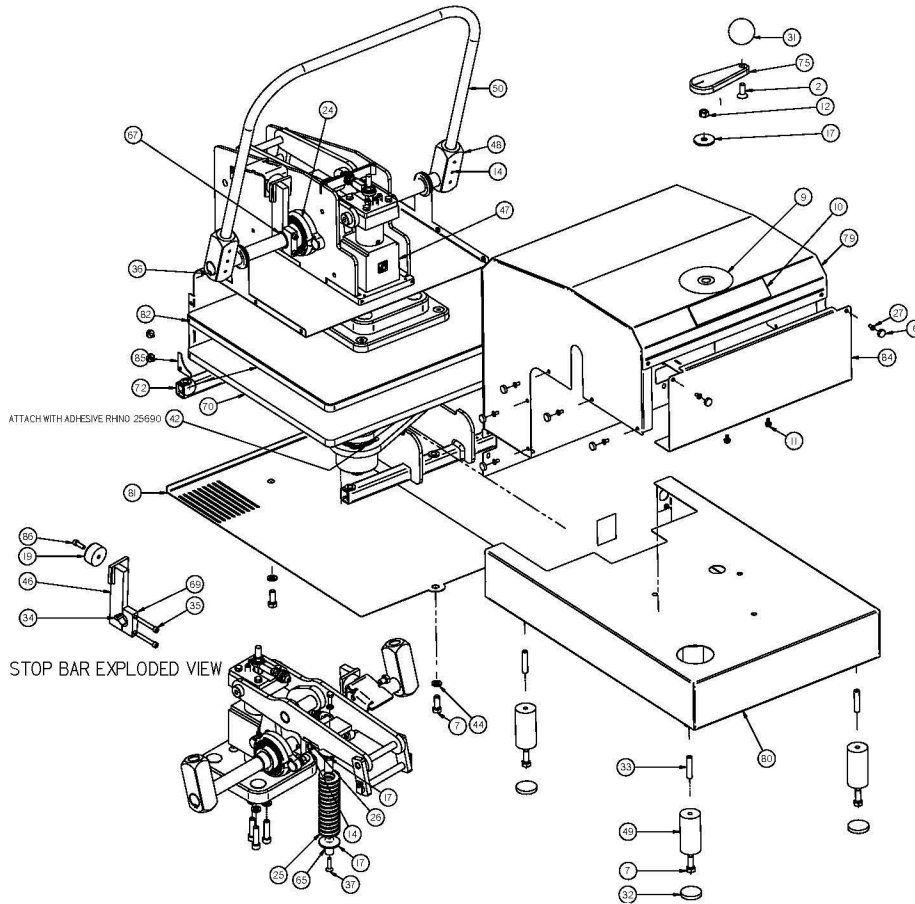

REPLACEMENT PARTS LIST (DXM-1620W MODEL)

ITEM#	PART#	TITLE	ITEM#	PART#	TITLE
1	10024	SCREW SET 3/8-24 X 2.000	55	8603103	M- LINK CRANK LARGE
2	10027	SCREW FHSKT 3/8-16X1.000 SS	56	8603105	DXE LINK FOLLOWER
3	10341	SCREW CPSKT 3/8-16X1.500 GD 8	57	8603110	DXE ADJUSTMENT SCREW CAP
4	10664	DECAL MADE IN USA	58	8603115	PIN CRANK LARGE
5	10678	BOLT 1/4-20x0.750	59	8603116	M- PIN ROD LARGE
6	10733	CAP, SCREW SNAP-ON #8-10 WHITE	60	8603117	DXE PIN STABILIZER
7	10850	BOLT 3/8-16 X 1.000	61	8603118	DXE PIN FOLLOWER
8	10963	DECAL, QR CODE DXP	62	8603124	LINK MAIN LARGE 1/32 CHAMFER LEFT
9	11300	DECAL, THICK THIN	63	8603128	LINK MAIN LARGE 1/32 CHAMFER RIGHT
10	11327	DECAL, DOUGHXPRESS DOMED 6.75 X 1.5	64	8603132	M-DXM PINION SHAFT
11	11404	SCREW MCH 10-32X0.375 SS	65	8603133	DXM SPRING HOLDER
12	14571	NUT 3/8-16 ZPS	66	8603134	SPRING PLATE UPPER
13	14647	NUT HEX JAM 3/8-16 NC ZP	67	8603502	DXE MAIN SHAFT BUSHING
14	15131	SCREW SET 1/4-20x0.250	68	8603503	M-DXE PIN RETAINER
15	15321	SCREW MCH 10-32x0.375 PHPH	69	8609117	DXM SHAFT CLAMP
16	16683	WASHER FLT .375x0.875x.078 ZPS	70	8620083	ASSY. DXM-CP LOWER PLATEN LV
17	25720	WASHER FLT .406X1.500X.120 ZPS	71	8620124	ASSY. DXM-CP UPPER PLATEN LV
18	28142	SCREW FHSKT 5/16-18x1.000	72	8620171	ASSY FRAME WITH SUPPORTS
19	31453	FOOT RUBBER 0.75x1.50x0.25	73	8621026	JACK SHAFT D-TXM-2-18
20	32224	SCREW SET 3/8-16x0.375 DP	74	8621100	P-ASSY UPPER PLATEN MOUNT PLATE
21	32228	WASHER LOCK HEL SPR #10 ZP	75	8621111	M-HANDLE LC
22*	33022	MANUAL OWNERS TX / D-TX	76	8621132	GROMMET 1.00IDX.095 GRV
23	33071	DETENT 3/8-16X0.188 BALL	77	8621153	M-DX JACK .5 HEX SHAFT
24	39586	BEARING 1-1/4" 2 BOLT FLANGE	78*	8621174	DX SERIES PACKAGING
25	39705	SPRING DIE M150-500	79	8621208	ASSY, UPPER HOUSING DXM 4.3" CLCD WHITE
26	39748	KEY STL .250x.250x1.75 UNDSZ	80	8621214	HOUSING, BOTTOM 4.3" CLCD STEEL WHITE
27	50180	SCREW MCH 10-32x0.375 PHPH SS	81	8621221	BOTTOM COVER 4.3" CLCD
28	50342	BOLT 3/8-16x0.500	82	8621223	DX HOUSING FRAME COVER 4.3" CLCD STEEL
29	61220	ROD END 3/8-24 RH FEM	83	8621237	HANDLE STOP, DX SHEETMETAL
30	62448	WIRE CABLE CLIP ADHESIVE BACK	84	8621252	PANEL FRONT, DX STEEL W NO DISPLAY
31	62561	KNOB PHENOLIC CL 852-PB	85	8621260	COVER, FRAME ARCH WHITE
32	63711	FOOT RUBBER 1-1/2"ODx1/4"	86	90134	SCREW CPSKT 1/4-20x0.750
33	63746	SCREW SET 3/8-16x1.750			
34	63916	KEY STL .250x.250x.750			
35	65242	SCREW CPSKT 1/4-20x1.750			
36	67490	KEY STL .250x.250x1.50 UNDSZ			
37	70077	SCREW FHSKT 1/4-20x1.000			
38	70268	DECAL HIX I.D. 3" X 3" SILVER			
39	70563	BOLT CAR 3/8-16x1.250			
40	70597	SCREW SET 5/16-24x0.625 CP			
41	70766	PLUG HOLE 7/8 STL NI PLATED			
42	71041	SEAL SHAFT 2.500			
43	73247	NUT 3/8-16 JAM NYLON INSERT ZPS			
44	79418	WASHER LOCK HEL SPR 3/8 ZP			
45	79426	WASHER LOCK HEL SPR 1/4 ZP			
46	8600450	DXM STOP BAR WELDMENT			
47	8600920	DP JACK SHAFT HOUSING ASSY			
48	8601081	M-DP DXM HANDLE ADAPTOR			
49	8601083	M-DP LEG 3"			
50	8601087	HANDLE, DXM STEEL			
51	8601217	M-DXE ADJSMNT SCREW RETAINER			
52*	8601219	M-DXE JACK ADJ STOP			
53	8601220	M-DXE DRIVE PIN			
54	8603101	DXE LINK STABILIZER			

REPLACEMENT PARTS LIST (DXM-1620SS MODEL)

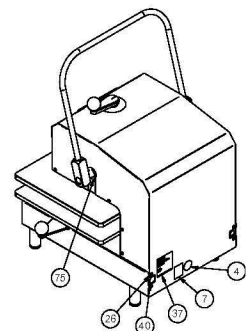
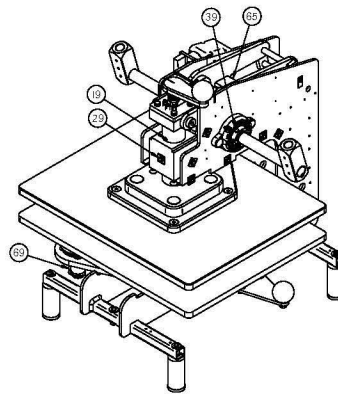
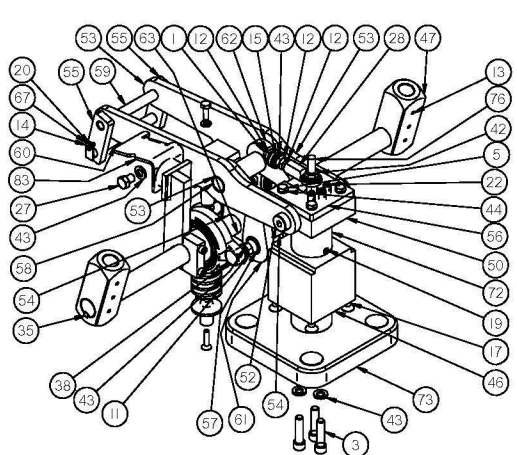
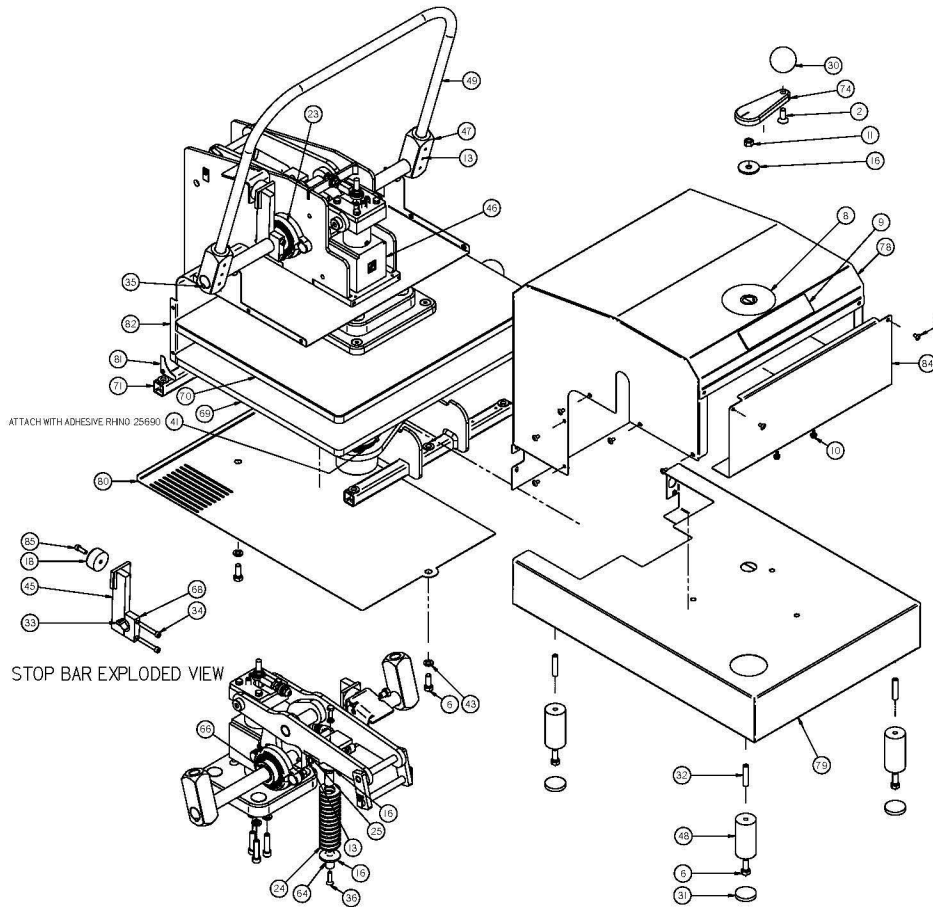

REPLACEMENT PARTS LIST (DXM-1620SS MODEL)

ITEM#	PART#	TITLE	ITEM#	PART#	TITLE
1	10024	SCREW SET 3/8-24 X 2.000	55	8603105	DXE LINK FOLLOWER
2	10027	SCREW FHSKT 3/8-16X1.000 SS	56	8603110	DXE ADJUSTMENT SCREW CAP
3	10341	SCREW CPSKT 3/8-16X1.500 GD 8	57	8603115	PIN CRANK LARGE
4	10664	DECAL MADE IN USA	58	8603116	M- PIN ROD LARGE
5	10678	BOLT 1/4-20x0.750	59	8603117	DXE PIN STABILIZER
6	10850	BOLT 3/8-16 X 1.000	60	8603118	DXE PIN FOLLOWER
7	10963	DECAL, QR CODE DXP	61	8603124	LINK MAIN LARGE 1/32 CHAMFER LEFT
8	11300	DECAL, THICK THIN	62	8603128	LINK MAIN LARGE 1/32 CHAMFER RIGHT
9	11327	DECAL, DOUGHXPRESS DOMED 6.75 X 1.5	63	8603132	M-DXM PINION SHAFT
10	11404	SCREW MCH 10-32X0.375 SS	64	8603133	DXM SPRING HOLDER
11	14571	NUT 3/8-16 ZPS	65	8603134	SPRING PLATE UPPER
12	14647	NUT HEX JAM 3/8-16 NC ZP	66	8603502	DXE MAIN SHAFT BUSHING
13	15131	SCREW SET 1/4-20x0.250	67	8603503	M-DXE PIN RETAINER
14	15321	SCREW MCH 10-32x0.375 PHPH	68	8609117	DXM SHAFT CLAMP
15	16683	WASHER FLT .375x0.875x.078 ZPS	69	8620083	ASSY. DXM-CP LOWER PLATEN LV
16	25720	WASHER FLT .406X1.500X.120 ZPS	70	8620124	ASSY. DXM-CP UPPER PLATEN LV
17	28142	SCREW FHSKT 5/16-18x1.000	71	8620171	ASSY FRAME WITH SUPPORTS
18	31453	FOOT RUBBER 0.75x1.50x0.25	72	8621026	JACK SHAFT D-TXM-2-18
19	32224	SCREW SET 3/8-16x0.375 DP	73	8621100	P-ASSY UPPER PLATEN MOUNT PLATE
20	32228	WASHER LOCK HEL SPR #10 ZP	74	8621111	M-HANDLE LC
21	33022	MANUAL OWNERS TX / D-TX	75	8621132	GROMMET 1.00IDX.095 GRV
22	33071	DETENT 3/8-16X0.188 BALL	76	8621153	M-DX JACK .5 HEX SHAFT
23	39586	BEARING 1-1/4" 2 BOLT FLANGE	77	8621174	DX SERIES PACKAGING
24	39705	SPRING DIE M150-500	78	8621211	ASSY, UPPER HOUSING DXM 4.3" CLCD SS
25	39748	KEY STL .250x.250x1.75 UNDSZ	79	8621217	HOUSING, BOTTOM 4.3" CLCD STAINLESS
26	50083	SCREW MCH 10-32X0.375 THPH SS	80	8621221	BOTTOM COVER 4.3" CLCD
27	50342	BOLT 3/8-16x0.500	81	8621226	COVER, FRAME ARCH STAINLESS STEEL
28	61220	ROD END 3/8-24 RH FEM	82	8621230	DX HOUSING FRAME COVER 4.3" CLCD SS
29	62448	WIRE CABLE CLIP ADHESIVE BACK	83	8621237	HANDLE STOP, DX SHEETMETAL
30	62561	KNOB PHENOLIC CL 852-PB	84	8621251	PANEL FRONT, DX SS NO DISPLAY
31	63711	FOOT RUBBER 1-1/2"ODx1/4"	85	90134	SCREW CPSKT 1/4-20x0.750
32	63746	SCREW SET 3/8-16x1.750			
33	63916	KEY STL .250x.250x.750			
34	65242	SCREW CPSKT 1/4-20x1.750			
35	67490	KEY STL .250x.250x1.50 UNDSZ			
36	70077	SCREW FHSKT 1/4-20x1.000			
37	70268	DECAL HIX I.D. 3" X 3" SILVER			
38	70563	BOLT CAR 3/8-16x1.250			
39	70597	SCREW SET 5/16-24x0.625 CP			
40	70766	PLUG HOLE 7/8 STL NI PLATED			
41	71041	SEAL SHAFT 2.500			
42	73247	NUT 3/8-16 JAM NYLON INSERT ZPS			
43	79418	WASHER LOCK HEL SPR 3/8 ZP			
44	79426	WASHER LOCK HEL SPR 1/4 ZP			
45	8600450	DXM STOP BAR WELDMENT			
46	8600920	DP JACK SHAFT HOUSING ASSY			
47	8601081	M-DP DXM HANDLE ADAPTOR			
48	8601083	M-DP LEG 3"			
49	8601087	HANDLE, DXM STEEL			
50	8601217	M-DXE ADJSMNT SCREW RETAINER			
51	8601219	M-DXE JACK ADJ STOP			
52	8601220	M-DXE DRIVE PIN			
53	8603101	DXE LINK STABILIZER			
54	8603103	M- LINK CRANK LARGE			

WARRANTY

BEFORE warranty repair you MUST get Prior Authorization: Call 1-800-835-0606 Warranty will be voided otherwise.

doughXpress® will automatically register the equipment on the date it was shipped to you or your distributor. If the equipment was not purchased directly from HIX, but through a distributor (either domestic or foreign), please keep a copy of their sales invoice showing the serial number and date it was sold/shipped to you with this warranty.

In this case, we will use the distributor's invoice date as the beginning warranty date. **STAPLE A COPY OF YOUR RECEIPT TO THIS WARRANTY** and keep in a safe place to provide verification of your warranty should a problem occur. Thank you.

Please fill in the following information and attach a copy of your receipt for your records.

Date Purchased: _____ **From:** _____
Model #: _____ **Serial #:** _____

This warranty applies to equipment manufactured by the HIX Corporation (HIX), Pittsburg, Kansas, U.S.A. HIX warrants to the original purchaser, the full line of doughXpress® product against defects in workmanship and material, except for wear and tear for a period of one year parts and labor limited warranty on most items, there are selected items which may carry a two year warranty (refer to owners manual.) All dough press carts, compressors, and accessories are warranted for 90 days from the date of purchase. Repairs include parts and labor only, excluding is the following:

1. Overtime Labor Rates
2. Expedited Freight for Parts
3. doughXpress® assumes no responsibility for down time or loss of product. All defective parts must be returned to doughXpress® for credit. Repairs must be pre-authorized by doughXpress® prior to work commencing.
4. Travel time is not covered by doughXpress®, unless pre-authorized by doughXpress®. In the event of a defect, doughXpress®, at its option, will repair, replace or substitute the defective item at no cost during this period subject to the limitations of insurance and shipping costs stated below.

This warranty does not cover normal wear and tear, damages due to accident, misuse/abuse, alterations or damage due to neglect, or lack of proper lubrication or maintenance. doughXpress® shall not be responsible for repairs or alterations made by any person without the prior written authorization by doughXpress®. This warranty is the sole and exclusive warranty of doughXpress® and no person, agent, distributor, or dealer of doughXpress® is authorized to change, amend or modify the terms set forth herein, in whole or in part.

In the case of a problem with the equipment identified herein, doughXpress® should be contacted during regular business hours to discuss the problem and verify an existing warranty. doughXpress® personnel will assist the customer to correct any problems which can be corrected through operation or maintenance instructions, simple mechanical adjustments, or replacement of parts. In the event the problem cannot be corrected by phone, and upon the issuance of a return authorization by doughXpress®, the equipment shall be returned to doughXpress® or an authorized service representative. All insurance, packaging and shipment/freight costs are solely the responsibility of the customer, and doughXpress® shall not be responsible for improper handling or damage in transit.

doughXpress® customer service personnel may be contacted for complete return authorization and reconditioning information. This expressed warranty is given in lieu of any and all other warranties, whether expressed or implied, including but not limited to those of merchantability and fitness for a particular purpose, and constitutes the only warranty made by doughXpress®. In no event shall doughXpress®' liability for breach of warranty extend beyond the obligation to repair or replace the nonconforming goods. doughXpress® shall not be liable for any other damages, either incidental or consequential, or the action as brought in contract, negligence or otherwise.

This warranty gives you specific legal rights and you may also have other rights which vary from state to state.



1201 E. 27th Terrace • Pittsburg, KS 66762 • U.S.A.

Phone: (800) 835-0606 • Fax: 620-231-1598

Web site: hixcorp.com • E-Mail: sales@hixcorp.com