



OPERATOR'S M A N U A L

OIL DISPOSAL SHUTTLE (Electric)

MODEL

ODS-450



HENNY PENNY
Engineered to Last

REGISTER WARRANTY ONLINE AT WWW.HENNYPENNY.COM

TABLE OF CONTENTS

Section	Page
Section 1. INTRODUCTION	1-1
1-1. Introduction.....	1-1
1-2. Features	1-1
1-3. Proper Care	1-1
1-4. Assistance	1-1
1-5. Safety	1-2
Section 2. ASSEMBLY	2-1
Section 3. OPERATION WITH EVOLUTION ELITE OPEN FRYERS.....	3-1
Section 4. OPERATION WITH 500 & 600 PRESSURE FRYERS	4-1
Section 5. DISPOSING OF OIL INTO DISPOSAL CONTAINER	5-1
Section 6. PART INFORMATION	6-1
6-1. Introduction.....	6-1
6-2. Genuine Parts	6-1
6-3. How to Order	6-1
6-4. Prices.....	6-1
6-5. Delivery.....	6-1
6-6. Warranty	6-1
6-7. Recommended Spare Parts for Distributors.....	6-1

Wiring Diagram

SECTION 1. SAFETY

Where information is of particular importance or is safety related, the words NOTICE, CAUTION, or WARNING are used. Their usage is described below:



SAFETY ALERT SYMBOL is used with **DANGER**, **WARNING**, or **CAUTION** which indicates a personal injury type hazard.



NOTICE is used to highlight especially important information.



CAUTION used without the safety alert symbol indicates a potentially hazardous situation which, if not avoided, may result in property damage.



CAUTION used with the safety alert symbol indicates a potentially hazardous situation which, if not avoided, may result in minor or moderate injury.



WARNING indicates a potentially hazardous situation which, if not avoided, could result in death or serious injury.



DANGER INDICATES AN IMMINENTLY HAZARDOUS SITUATION WHICH, IF NOT AVOIDED, WILL RESULT IN DEATH OR SERIOUS INJURY.

SECTION 2. ASSEMBLY

USING BOLTS & NUTS PROVIDED, ATTACH HANDLE TO SHUTTLE.



USING PIPE THREAD SEALANT, THREAD THE HOSE INTO PUMP AND ATTACH QUICK DISCONNECT TO SHUTTLE

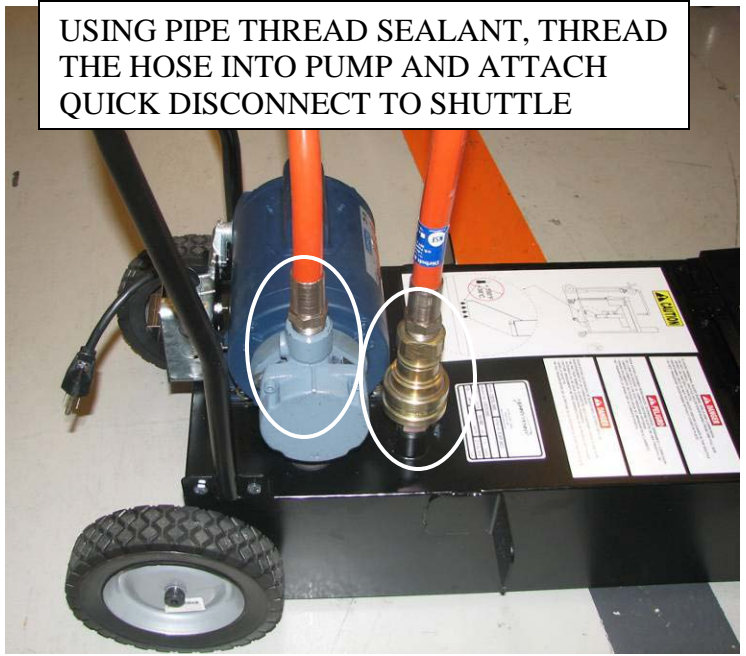

HANG THE PRESSURE FRYER "FUNNEL" & POWER CORD ON HANDLE



READY FOR USE

SECTION 3. OPERATION WITH EVOLUTION ELITE OPEN FRYERS



Figure 1



Figure 2



Figure 3



Figure 4

1. Open the door, lift-up on the drain pan stop and pull-out the drain pan assembly, using the handle on the drain pan. Figures 1 & 2.
2. Release cover latch, and hinge back cover on oil disposal shuttle. Figure 3. Make sure crumb catcher is in place.
3. Roll oil disposal shuttle under fryer until it stops. Make sure drain aligns with opening in shuttle. Figure 4.



TO AVOID PERSONAL INJURY, BURNS, SPILLS, AND CORROSION:

- **DO NOT OVERFILL. SHUTTLE HOLDS OIL FROM ONE FULLSIZE VAT OR TWO SPLIT VATS ONLY**
- **DO NOT PUT WATER AND/OR CLEANER IN THE SHUTTLE OIL ONLY**
- **DO NOT TRANSPORT OIL WITHOUT COVER IN PLACE**

4. Using the fryer controls, press and hold **F** (on either side) until display shows *FILTER MENU*, along with "1.EXPRESS FILTER".
5. Press and release **▶** twice until display shows "3.DISPOSE". Press **√** button and display shows "DISPOSE?" along with "YES NO".



To reduce the risk of fire or electrical shock, do not empty more than one full vat or two split vats at one time.

6. With discard shuttle rolled into place, press √ button and display shows “OPEN DRAIN”. Pull-out on drain knob to open drain and display shows “DRAINING”. Oil now drains from the vat into the shuttle.

NOTICE

If oil disposal shuttle is not properly in place, “IS DISPOSAL UNIT IN PLACE?” shows in display. Adjust the bracket on the front of the shuttle as needed by loosening the 4 nuts securing the bracket and moving the bracket up or down. Once properly adjusted, the display shows “DRAINING”. Figure 5.



Figure 5

7. Display shows “VAT EMTY”, along with “YES NO”. Verify that vat is empty, and press √ button.
8. Display shows “CLN VAT COMPLETE”, along with “YES NO”. Once vat is clean, press √ button and close drain.
9. Display shows “MANUAL FILL POT”, followed by “VAT FULL”, along with “YES NO”. Fill the vat to the lower indicator line on the rear of the vat and then press √ button. Controls return to normal operation.

SECTION 4. OPERATION WITH 500 & 600 PRESSURE FRYERS



Figure 1



Figure 2

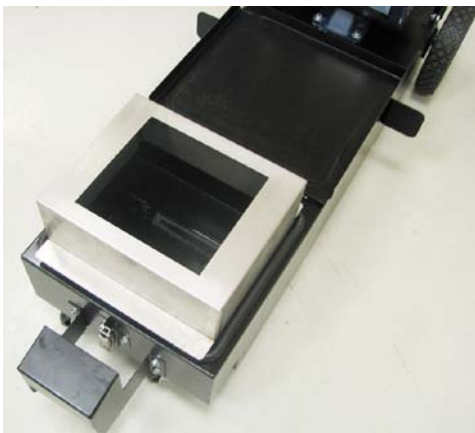

Figure 3

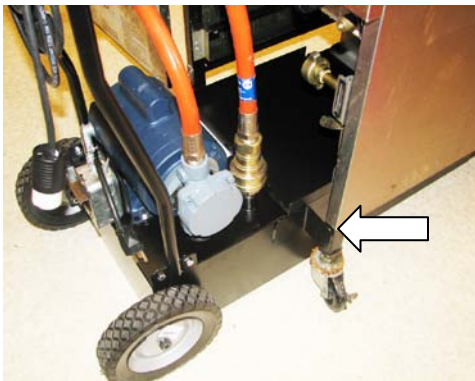

Figure 4

1. Move the fryer main power switch to the OFF position.
2. Remove and empty the condensation drain pan.
3. Disconnect the filter union and remove the drain pan from under the frypot.



The filter union could be hot! Use protective cloth or glove, or severe burns could result.

4. Release cover latch, and hinge back cover on oil disposal shuttle. Figure 2. Make sure crumb catcher is in place.
5. Using the “funnel” on the back of the handle, place it over the opening of the shuttle. Figure 3.
6. Roll oil disposal shuttle under fryer until the stop brackets on both sides of the shuttle contacts the frame. Figure 4. This assures drain aligns with opening in shuttle.



TO AVOID PERSONAL INJURY, BURNS, SPILLS, AND CORROSION:

- **DO NOT OVERFILL. SHUTTLE HOLDS OIL FROM ONE FULLSIZE VAT OR TWO SPLIT VATS ONLY**
- **DO NOT PUT WATER AND/OR CLEANER IN THE SHUTTLE OIL ONLY**
- **DO NOT TRANSPORT OIL WITHOUT COVER IN PLACE**

7. Turn drain handle and drain oil into shuttle.

SECTION 5. DISPOSING OF OIL INTO DISPOSAL CONTAINER

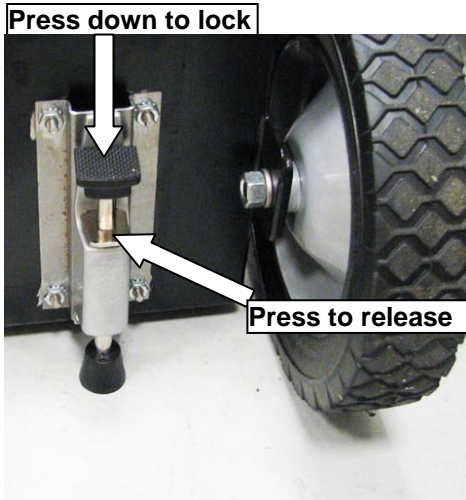

Figure 1

1. Remove the oil disposal shuttle from under fryer and replace with the filter pan assembly.
2. Close the cover on shuttle and roll oil disposal shuttle to disposal container.
3. Press down on top of brake to secure unit in place. Figure 1.



Figure 2

4. Disconnect fitting from top of ODS and connect to disposal container. Figure 2.

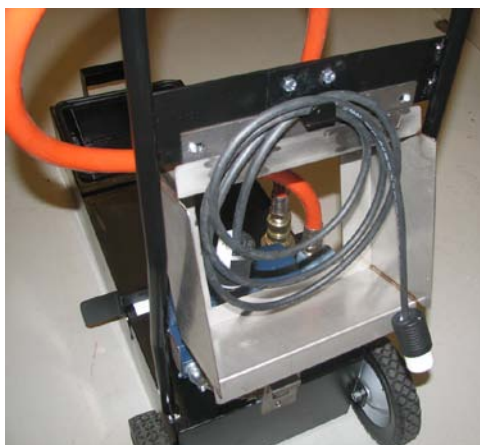

Figure 3

5. Using the power cord on the back of the shuttle handle, plug it into the short cord from the junction box. Figures 3 & 4



Figure 4

6. Turn power switch to the ON position. Figure 4.



Figure 5

7. Plug the shuttle electrical cord into the receptacle under the disposal container control, and then press & hold switch on container controls to pump oil from shuttle to the container. Figure 5.
8. Once shuttle is empty, release switch and unplug the electrical cord and wrap back onto the hook on the shuttle handle.
9. Using gloves or protective cloth, disconnect the fitting from the disposal container and connect it back onto the shuttle. Figure 6.



Disconnect fitting could be hot! Use protective cloth or gloves when disconnecting fitting, or severe burns could result.



Figure 6

CLEANING

Daily, remove the crumb catcher (Figure 6) and take it to a sink and clean with soap and water. Clean the exterior of the shuttle with a soft cloth and soap and water. It's not necessary to clean the interior of the unit, but if desired, it can be wiped down with paper towels.



To avoid damage to pump, do not use water or water-based liquids to clean the interior of the shuttle.

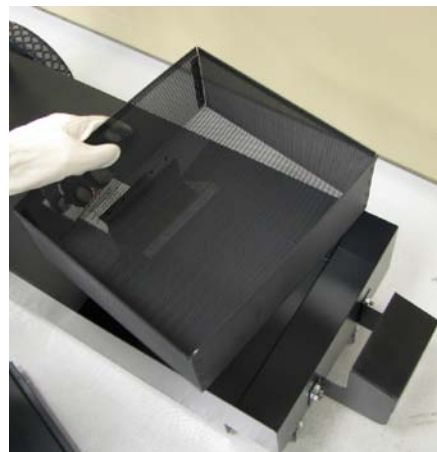

Figure 7

SECTION 6. PARTS INFORMATION

6-1. INTRODUCTION

This section identifies and lists the replaceable parts of the Henny Penny Oil Disposal Shuttle.

6-2. GENUINE PARTS

Use only genuine Henny Penny parts in your unit. Using a part of lesser quality or substitute design may result in unit damage or personal injury.

6-3. HOW TO FIND PARTS

To find items you want to order from the Parts List, proceed as follows:

1. Refer to the exploded drawing in this section to identify the part needed.
2. Use the item number from the exploded drawing to locate the corresponding part in the parts list in this section. In this list will be the Henny Penny part number and description of the part.

6-4. HOW TO ORDER PARTS

Once the part you want to order has been found in the Part List, write down the following information:

1. From the exploded drawing and Parts List (Sample)
Item Number 15
Part Number 77815
Description WHEEL – 8 INCH – ODS
2. From the data plate (Sample)
Serial Number 00100

6-5. PRICES

Your distributor has a price parts list and will be glad to inform you of the cost of yours parts order.

6-6. DELIVERY

Commonly replaced items are stocked by your independent Henny Penny distributor and will be sent out when your order is received. Other parts will be ordered by the distributor from Henny Penny Corporation. Normally, these will be sent to your distributor within three working days.

6-7. WARRANTY

All replacement parts (except lamps and fuses) are covered under warranty for 90 days against manufacturing defects and workmanship. If damage occurs during shipping, notify the carrier at once so that a claim may be properly filed. Refer to the warranty in this manual for other rights and limitations.

6-8. RECOMMENDED SPARE PARTS FOR DISTRIBUTORS

Recommended replacement parts are indicated with A or B in the parts lists:

A = parts to be stocked on service vans or trucks

B = parts to be stocked at the distributor/KES location.

Inventory on all other parts not identified, should be based upon usage in the territory. Please use care when ordering recommended parts, because all voltages and variations are marked. Distributors should order parts based upon common voltages and equipment sold in their territory.

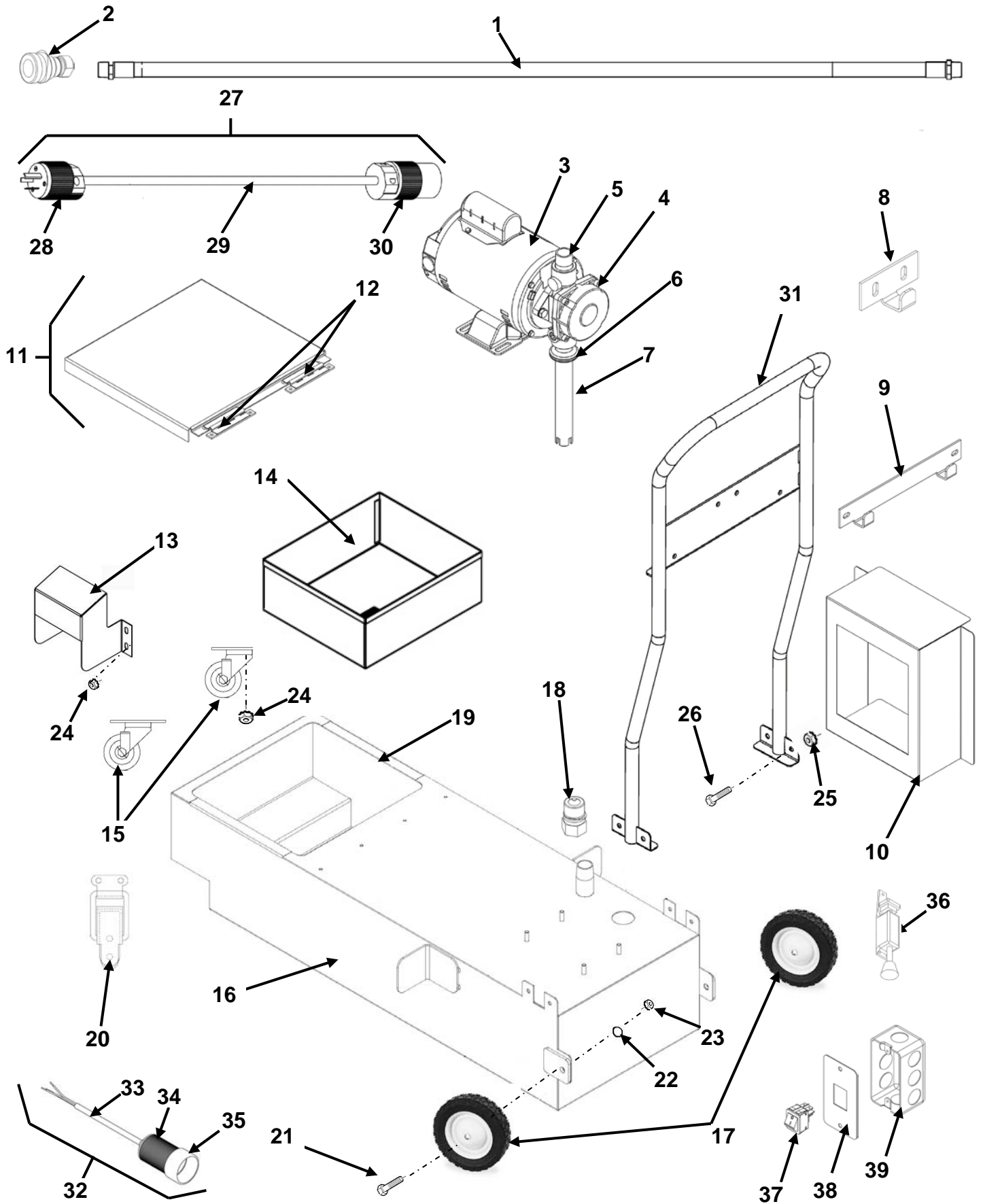

Item Number	Part Number	Description	Qty
B 1	21753	ASSY – FILTER HOSE ODS	1
B 2	21612	DISCONNECT - FEMALE	1
3	69356	PUMP & MOTOR ASSY	1
B 3	67583	MOTOR, 1/2 HP - 50/60 Hz	1
B 4	17437	PUMP ASSEMBLY	1
5	FP02-060	NIPPLE – ¾ CLOSE SS	1
6	MS01-583	GROMMET – HIGH TEMP FLEXIBLE	1
7	88302	NIPPLE – DOLLY OIL PICK UP	1
8	88295	BRACKET – CORD HANGER	1
9	91044	BRACKET – ODS FUNNEL HANGER	1
B 10	88746	FUNNEL – ODS – 500/600	1
11	84001	ASSY -- COVER ODS DRAIN PAN DOLLY	1
12	83993	HINGE	2
*	SC01-113	SCREW--#6-32 X 9/16 PHILLIPS, PAN HD	4
*	NS02-005	NUT--HEX--KEPS #6-32	4
13	84519	BRACKET – DRAIN SW ENGAGEMENT LV	1
B 14	84453	BASKET – CRUMB	1
B 15	19004	CASTER 2” SWIVEL PLATE	2
16	88707	WELD ASSY – ODS DRAIN PAN DOLLY	1
B 17	77815	WHEEL – 8 INCH – ODS	2
B 18	21611	DISCONNECT – MALE	1
B 19	84614	SEAL – COVER	1
A 20	MS01-532	LATCH	1
20*	SC01-049	SCREW--#6-32 X 3/8 PHILLIPS, PAN HD	2
20*	NS02-005	NUT--HEX--KEPS #6-32	2
20*	83994	BRACKET-LATCH MOUNTING	1
21	SC06-074	SCREW – ½ x 1-1/2 SHOULDER	2
22	LW01-010	LOCKWASHER – SPLIT-RING 3/8 S	2
23	NS01-001	NUT – HEX 3/8-16	2
24	NS02-006	NUT – HEX – KEPS #10-24 C	23
25	NS02-002	NUT – HEX – KEPS 1/4-20 C	4
26	SC01-057	SCREW – ¼-20 x ½ HEX HD C	4
B 27	88331-01	ASSY – PLUG & CORD 125V – 15A	1
28	42512	PLUG – 125V – NEMA L5-15P	1
29	MS01-139	CABLE - #16/3 BLACK 90C JACKET	8 FT
30	91064	RECEPTACLE – STR BLADE 15A-125V	1
31	84368	WELD ASSY – DOLLY HANDLE	1
B 32	92664	ASSY – 6 IN. CORD – 15A-125V	1
33	92663	POWER CORD – 6 IN.	1
34	92658	PLUG – 15A-125 – NEMA 5-15P	1
35	92662	BOOT – WEATHER PROOF	1
36	92009	BRAKE – ODS DOLLY	1
A 37	72277	SWITCH – POWER SPLASH PROOF	1
38	21635	COVER – JUNCTION BOX	1
39	23459	BOX – JUNCTION	1

Recommend Parts: A=Truck Stock/B=Dist. Stock

*not shown

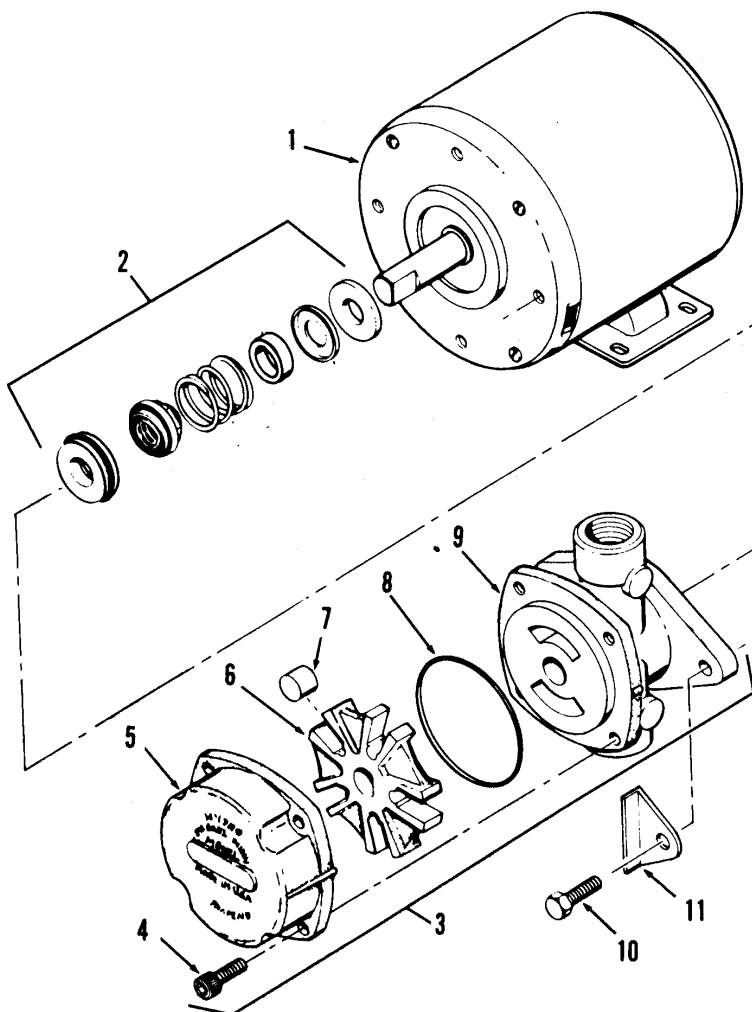

FILTER MOTOR AND PUMP

Item No.	Part Number	Description	Per Assy
B 1	67583	MOTOR, 1/2 HP - 50/60 Hz	1
A 2	17476	SEAL KIT	1
3	17437	PUMP ASSEMBLY	1
4	SC01-132	SCREW, Pump Cover	1
5	17451	COVER, Pump	1
B 6	17447	ROTOR, Pump	1
A 7	17446	ROLLER, Pump	5
A 8	17453	O-RING	1
9	17454	BODY, Pump	1
10	17456	SHIELD, Pump	2
11	SC01-026	SCREW, Pump Shield	1

Recommend Parts: A=Truck Stock/B=Dist. Stock

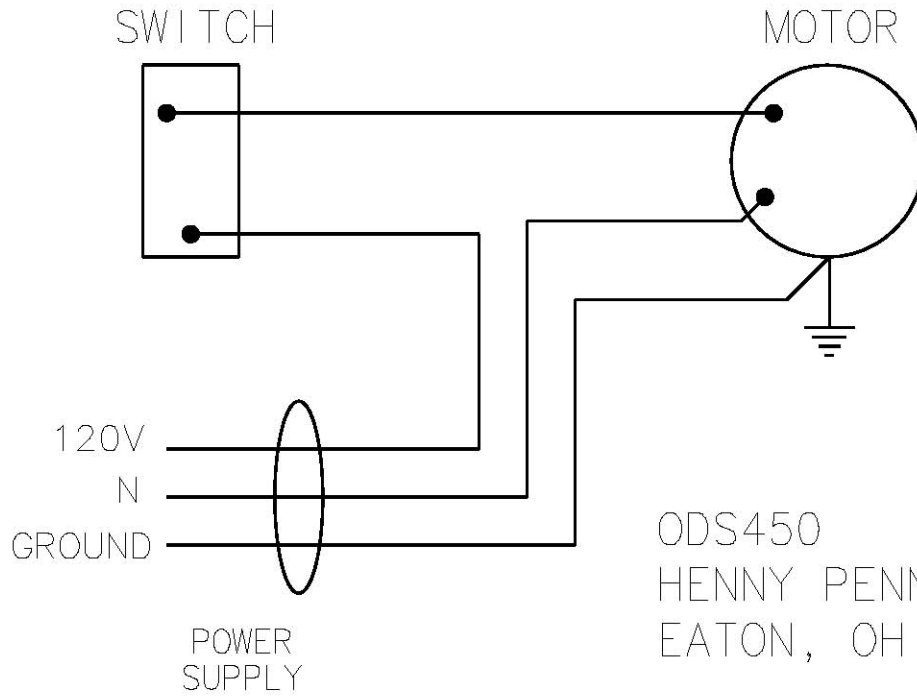

ODS450
HENNY PENNY CORP.
EATON, OHIO 45320

91356_A

* FM05 - 065 - B* Henny Penny Corp., Eaton, Ohio 45320, Revised 6-25-13



Henny Penny Corporation
P.O.Box 60
Eaton, OH 45320

1-937-456-8400
1-937-456-8402 Fax

Toll free in USA
1-800-417-8417
1-800-417-8434 Fax

www.hennypenny.com