



Henny Penny

Split Vat & Full Vat

Open Fryers – Gas

Model LVG-102

Model LVG-103

Model LVG-104

TECHNICAL MANUAL

TABLE OF CONTENTS

Section	Page
Section 1. TROUBLESHOOTING.....	1-1
1-1 Introduction	1-1
1-2 Safety.....	1-1
1-3 Troubleshooting.....	1-2
1-4 Error Code Table	1-7
Section 2. INFO, FILTER & TEMP BUTTON STATS	2-1
2-1 INFO Button Stats	2-1
2-2 FILTER Button Stats	2-1
2-3 TEMP Button Stats.....	2-1
2-4 HP Info Mode	2-2
Section 3. LEVEL 1 PROGRAMMING	3-1
3-1 Modifying Product Settings	3-1
3-2 AIF Clock.....	3-3
3-3 Deep Clean Mode.....	3-4
3-4 Fryer Setup	3-5
Section 4. LEVEL 2 PROGRAMMING	4-1
4-1 Advanced Product Settings	4-1
4-2 E-Log (error code log).....	4-2
4-3 Passwords	4-3
4-4 Alert Tone (and volume)	4-3
4-5 Filter After	4-4
4-6 Filter Time	4-4
Section 5. LEVEL 3 PROGRAMMING	5-1
5-1 Additional Advanced Product Settings	5-1
5-2 Special Programming	5-2
5-3 Clock Set	5-6
5-4 Data Comm & Heat Control.....	5-6
5-5 Tech Mode.....	5-7
5-6 Stats Mode.....	5-12
Section 6. INFORMATION MODE.....	6-1
6-1 Info Mode	6-1
Section 7. MAINTENANCE SECTION.....	7-1
7-1 Preventive Maintenance.....	7-1
7-2 Oil Channel Clean-Out.....	7-1
7-3 Control Panel and Menu Card Replacement	7-2
7-4 High Temperature Limit Control.....	7-3
7-5 Main Power switch.....	7-5
7-6 Probe Replacement.....	7-6

TABLE OF CONTENTS

Section	Page
Section 7. MAINTENANCE SECTION (Continued)	
7-7 Solenoid Valves	7-9
7-8 Drain Valve Actuators	7-11
7-9 Filter Pump & Motor	7-12
7-10 AIF Pump	7-14
7-11 AIF PC Board	7-14
7-12 Transformers	7-15
7-13 Filter Motor Relay	7-17
7-14 Gas Control Valves	7-17
7-15 Blower Motors	7-19
7-16 Drain Pan Switch	7-20
7-17 Filter & JIB Lights	7-21
7-18 Air Pressure Switches	7-22
7-19 Ignitor & Flame Sensor Assembly	7-23
7-20 Ignition Modules	7-24
7-21 Pressure Transducer	7-25
Section 8. PARTS SECTION	
8-1 Introduction	8-1
8-2 Genuine Parts	8-1
8-3 When Ordering Parts	8-1
8-4 Prices	8-1
8-5 Delivery	8-1
8-6 Warranty	8-1
8-7 Recommended Spare Parts for Distributors	8-1
Apenndix A A-1 Wiring Diagrams & Scematics	A-1

SECTION 1. TROUBLESHOOTING

1-1. INTRODUCTION

This section provides troubleshooting information in the form of an easy to read table.

If a problem occurs during the first operation of a new fryer, recheck the installation per the Installation Section of the operator's manual.

Before troubleshooting, always recheck the operation procedures per Section 3 of the operator's manual.

1-2. SAFETY

Where information is of particular importance or safety related, the words DANGER, WARNING, CAUTION, and NOTICE are used. Their usage is described below.



SAFETY ALERT SYMBOL is used with DANGER, WARNING, or CAUTION which indicates a personal injury type hazard.



NOTICE is used to highlight especially important information.



CAUTION used without the safety alert symbol indicates a potentially hazardous situation which, if not avoided, may result in property damage.



CAUTION indicates a potentially hazardous situation which, if not avoided, may result in minor or moderate injury.



WARNING indicates a potentially hazardous situation which, if not avoided, could result in death or serious injury.



DANGER INDICATES AN IMMINENTLY HAZARDOUS SITUATION WHICH, IF NOT AVOIDED, WILL RESULT IN DEATH OR SERIOUS INJURY.

1-3. TROUBLESHOOTING

To isolate a malfunction, proceed as follows:

1. Clearly define the problem (or symptom) and when it occurs.
2. Locate the problem in the Troubleshooting table.
3. Review all possible causes. Then, one-at-a-time work through the list of corrections until the problem is solved.
4. Refer to the maintenance procedures in the Maintenance Section to safely and properly make the checkout and repair needed.



If maintenance procedures are not followed correctly, injuries and/or property damage could result.

Problem	Cause	Correction
POWER SECTION		
<p>With power switch in ON position, the fryer is completely inoperative (NO POWER)</p>	<ul style="list-style-type: none"> • Open circuit 	<ul style="list-style-type: none"> • Check to see that unit is plugged in • Check the breaker or fuse at supply box • Check voltage at wall receptacle • Check MAIN POWER switch; replace if defective • Check cord and plug • Reset transformer circuit breaker
HEATING OF SHORTENING SECTION		
<p>Oil will not heat</p>	<ul style="list-style-type: none"> • Blown fuse or tripped • Faulty power switch. • Faulty cord and plug • Faulty drain switch • Faulty PC Board • High limit control switch tripped 	<ul style="list-style-type: none"> • Reset breaker or replace fuse circuit breaker at supply box or control panel • Check power switch • Check cord and plug • Check power at receptacle • Check drain switch • Check control panel per maintenance section and replace as needed • Let unit cool down (15-20 minutes), press red reset button under right side of the controls; if high limit does not reset, high limit must be replaced <div data-bbox="1047 1591 1453 1969" style="text-align: right;"> </div>

Problem	Cause	Correction
HEATING OF SHORTENING SECTION (Continued)		
Oil will not heat (Continued)	<ul style="list-style-type: none"> • Drain valve open • Faulty temperature probe • Faulty gas valve 	<ul style="list-style-type: none"> • Close drain valve • Replace temperature probe • Check gas valve
Oil heating too slow	<ul style="list-style-type: none"> • Low gas pressure • Wire(s) loose • Burnt or charred wire connection 	<ul style="list-style-type: none"> • Have gas pressure checked • Tighten • Replace wire and clean connectors
Oil overheating	<ul style="list-style-type: none"> • Programming wrong • Faulty PC board • Faulty temperature probe • Faulty gas valve 	<ul style="list-style-type: none"> • Check temperature setting in the program mode • Replace control board if heat indicator stays on past ready temperature • Check probe calibration and replace if temperature is off ± 5 degrees • Check gas valve

Problem	Cause	Correction
OIL LEVEL SECTION		
Oil foaming or boiling over vat	<ul style="list-style-type: none"> • Water in oil • Improper or bad oil • Improper filtering • Cold zone (bottom of vat) full of crumbs • Improper rinsing after cleaning the fryer 	<ul style="list-style-type: none"> • At end of a Cook Cycle, drain and clean vat; add fresh oil • Use recommended oil • Refer to the procedure on filtering the oil • Filter oil • Rinse the vat thoroughly to remove any cleaning agent in the vat
Oil will not drain from vat	<ul style="list-style-type: none"> • Drain valve clogged with • Faulty actuator • Oil channel clogged 	<ul style="list-style-type: none"> • Open valve, using cleaning brush, force crumbs through drain valve • Replace actuator • Access the clean-out plug on the sides of the unit (see Oil Channel Clean-out Section)
Oil leaking through drain valve	<ul style="list-style-type: none"> • Obstruction in drain • Faulty drain valve 	<ul style="list-style-type: none"> • Remove obstruction • Replace drain valve
Vat is under-filled	<ul style="list-style-type: none"> • Locations with RTI, the 3-way valve is stuck open • JIB is low or empty • JIB oil line is clogged or collapsed 	<ul style="list-style-type: none"> • The RTI system can be disconnected until RTI repairs the valve • Fill the JIB • Check JIB line
Bubbles in oil during entire filtering process	<ul style="list-style-type: none"> • Filter pan needs cleaned • Filter pan not completely engaged • Filter pan clogged • Damaged o-ring on filter line tube on fryer 	<ul style="list-style-type: none"> • Clean filter pan and change pad • Make sure filter pan return line is pushed completely into the receiver on the fryer • Clean pan and change pad • Change O-ring

Problem	Cause	Correction
FILTER MOTOR SECTION		
Filter motor runs but pumps oil slowly	<ul style="list-style-type: none"> • Filter line connections loose • Drain pan o-rings damaged or missing • Filter paper or pad clogged 	<ul style="list-style-type: none"> • Tighten all filter line connections • Install new o-rings • Change filter paper or pad
Filter motor will not run	<ul style="list-style-type: none"> • Power cord for vat #1 is not plugged-in • Thermal reset button on the rear of the pump motor is tripped 	<ul style="list-style-type: none"> • Plug power cord into receptacle • Remove the right side panel and allow time for the motor to cool and then, using a screwdriver, press hard against the button until it clicks <div data-bbox="1029 856 1451 1142" style="text-align: center;"> </div>
DISPLAYED PROMPT SECTION		
“IS POT FILLED” filter error prompt	<ul style="list-style-type: none"> • All oil did not completely return after a filter cycle • Filter pad clogged 	<ul style="list-style-type: none"> • Have manager follow prompts • Is JIB full? If not, fill JIB • Replace filter pad/clean pan.
“CHECK PAN” prompt	<ul style="list-style-type: none"> • Filter drain pan missing • Filter drain pan not completely engaged • Filter drain interlock switch not engaged 	<ul style="list-style-type: none"> • Find pan and install • Adjust filter drain pan position • Check drain microswitch
“CHANGE FILTER PAD” prompt appears	<ul style="list-style-type: none"> • Filter pad has not been changed within a 24hr time period; Main power switch was turned off during filter pad change • Drain pan microswitch stuck 	<ul style="list-style-type: none"> • Replace old filter pad with NEW filter pad with main power switch turned on. *NOTE* 24/7 store replace filter twice a day. • Check drain microswitch

1-4. ERROR CODES

In the event of a control system failure, the digital display shows an error message. The message codes are shown in the DISPLAY column below. A constant tone is heard when an error code is displayed, and to silence this tone, press any button.

DISPLAY	CAUSE	CORRECTION
“E-4”	Control board overheating	Turn switch to OFF position, then turn switch back to ON; if display shows “E-4”, the control board is getting too hot; check the louvers on each side of the unit for obstructions
“E-5”	Oil overheating	Turn switch to OFF position, then turn switch back to ON; if display shows “E-5”, the heating circuits and temperature probe should be checked
“E-6A”	Temperature probe open	Turn switch to OFF position, then turn switch back to ON; if display shows “E-6A”, the temperature probe should be checked
“E-6B”	Temperature probe shorted checked	Turn switch to OFF position, then turn switch back to ON; if display shows “E-6B”, temperature probe should be
“E-10”	E-10A- tripped above 300F E-10B- tripped below 300F E-10C- tripped while cooking E-10D- tripped <5min. of Auto Filter E-10F- tripped during filter cycle E-10M- tripped during melt mode E-10Y- tripped <5min of “YES” to “IS THE POT FULL?” prompt	Allow fryer to cool for 15-20 minutes; reset high limit by pressing down & releasing raisedside of the switch for the vat that is not operating; a single reset switch is found behind the door of each well; if high limit does not reset, high limit must be replaced 
“E-15”	Drain valve open	Clean and/or close fish vat drain valve; if clean and closed, have drain switch continuity checked
“E-18-A” “E-18-B” “E-18-C”	Left level sensor open Right level sensor open Both level sensors open	Turn switch to OFF position, then turn switch back to ON; If display still indicates a failed sensor, check the connectors at the control board; check sensor & replace, if necessary
“E-20-A” “FAN SENSOR STUCK CLOSED”	Pressure switch failure/ Wiring problem	If fan is not running, have pressure switch checked; should be open circuit, if no air pressure If fan is running, wiring error

1-4. ERROR CODES (Continued)

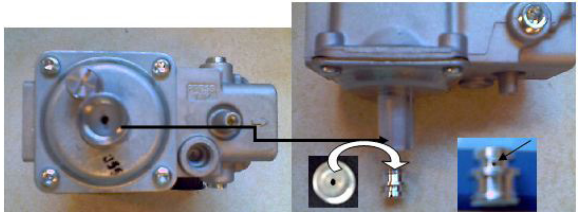
DISPLAY	CAUSE	CORRECTION
“E-20-B” “NO DRAFT” “CHECK FAN”	Pressure Switch failure/ hose loose Draft Fan failure/ low voltage/ Flue or hood obstruction	Press power button to vat off and back on again, if E-20-B persists, have pressure switch checked; should be open circuit if no air pressure; make sure hose is connected to fan and pressure switch Have draft fan checked; low voltage going to fan Check the fryer flue and hood system for obstructions
“E-20-D”	<ul style="list-style-type: none"> • Failure to ignite/ no flame sense • Plugged atmospheric equalization hole in regulator cap resulting in pilot flame slowly fading 	<ul style="list-style-type: none"> • Press power button to vat off and back on again, if E-20-D persists, check gas line connections; check gas shutoff valve; check ignition module; check gas valve; check flame sensor gap; check gas valve, and check ignition module wiring • Clear obstruction from hole 
“E-21”	Slow heat recovery	Have a certified service technician check the fryer for correct gas supply and pressure to the unit; have the gas valves checked; have unit checked for loose or burnt wires
“E-22” “NO HEAT”	Burner not igniting	Have gas valve and heat circuit checked
“E-41” , “E-46”	Programming failure	Turn switch to OFF, then back to ON; if display shows any of these error codes, re-initialize the controls; if error code persists, check control board and replace as needed
“E-47”	Analog converter chip or 12 volt supply failure	Turn switch to OFF, then back to ON; if “E-47” persists, replace the PC board
“E-48”	Input system error	Turn switch to OFF, then back to ON; have control PC board replaced if “E-48” persists
“E-54-C”	Temperature input error	Turn switch to OFF, then back to ON; have control PC board replaced if “E-54C” persists

1-4. ERROR CODES (Continued)

DISPLAY	CAUSE	CORRECTION
“E-60”	AIF PC board not communicating with control PC board	Turn switch to OFF, then back to ON; if “E-60” persists, check 1.5 amp fuse on AIF PC board on International units only; check connector between the PC boards; replace AIF PC board or control PC board if necessary
“E-62A”	Communication error	-Verify the OQM sensor wiring is correct. -Replace cable. -Replace Sensor
“E-62B”	Wrong calibration parameter	Replace OQM Sensor
“E-62C”	Shorted capacitance	Replace OQM Sensor
“E-62D”	Shorted RTD	Replace OQM Sensor
“E-62E”	Open RTD	Replace OQM Sensor
”E-62F”	Open capacitance	Replace OQM Sensor
”E-62G”	Out of range (TPM value over 35)	Replace oil and take a TPM reading, if the error is still present replace OQM sensor.
“E-70-C”	Drain valve jumper wire missing or disconnected	Have the jumper wire checked on the PC board at drain switch interlock position
“E-82A”	Selector Valve not detected	Have wiring checked between Selector Valve and AIF board
“E-82B”	Selector Valve failed	Have the “Home” switch on Selector Valve checked
“E-83” “PRES-SURE ” “TOO HIGH”	Pressure Trasducer senses too high pressure in AIF system	Check AIF system or the RTI quick-disconnect; See details below;
“E-83-A”	Pressure too high	Check AIF system in Vat #1
“E-83-B”	Pressure too high	Check AIF system in Vat #2
“E-83-C”	Pressure too high	Check AIF system in Vat #3
“E-83-D”	Pressure too high	Check AIF system in Vat #4
“E-83-E”	Pressure too high	Check AIF system in Vat #5
“E-83-J”	RTI “JIB FILL” switch ON when pressure too high	Check JIB fill valves
“E-83-R”	RTI “DISPOSE” switch ON when pressure too high	Check RTI quick-disconnect behind fryer; RTI phone no. if needed: 888-796-4997
“E-83-Z”	Unknown source	Check RTI system & JIB fill valve
“E-93-A”	24VDC tripped	Have drain actuator checked

SECTION 2. INFO, FILTER & TEMP BUTTON STATS

2-1. INFO BUTTON STATS

Recovery Information for each Vat/OQM Information

1. Press and release  and REC shows in left display and the recovery time that oil temperature went from 250°F (121°C) to 300°F (149°C) shows in the right display. For example,

REC	5:30
-----	------

 means it took 5 minutes and 30 seconds for the oil temperature to recover to 300°F (149°C) from 250°F (121°C).

Pressing the  button twice shows the 2nd language, if programmed.



NOTICE

If no buttons are pressed within 5 seconds in any of stats modes, the controls revert back to normal operation.

- 1a. Press and release , the display will show the last TPM reading, date of the last TPM reading, and time stamp of last TPM reading (only if OQM sensor is installed and enabled).

2-2. FILTER BUTTON STATS



Cook Cycles Remaining before Filtering

1. Press and release either  or  and left display shows “COOKS REMAIN” and right display shows the number of cook cycles before the next auto filter. For example,



REMA IN	3	6
---------	---	---

 means after 3 more cook cycles on the left vat, the controls ask operator if they are ready to filter or not. But, 6 more cook cycles remain on the right vat.

Time and Date

2. Press either  or  twice and time-of-day and date shows in the displays.

Filter Pad Usage

3. Press either  or  three times and number of hours the present filter has been used is shown in the displays.

2-3. TEMP BUTTON STATS

Actual Oil Temperature

1. Press  and the actual oil temperature shows in the display, for each vat.

Set-point Temperature

2. Press  twice and SP shows in the display, along with the set-point (preset) temperature of each vat.

2-4. HP INFO MODE

Cook Cycles Remaining before Filtering

Press and release both  and  at the same time to

enter HP Info Mode. You can view the following option in HP Info Mode:



1. E-Log
2. Last Load
3. Daily Stats
4. Review Usage
5. Inputs HDE (to check: high limit, drain switch jumper, and tilt switch)
6. Outputs S_H (saftey contactor / heat contactor)
7. Oil Temperature
8. CPU Temp
9. Communication OQM Sensor
10. Analog
11. Activity Log
12. Oil Levels (see if low level sensing temperature difference between probes).
13. Pumps and Valves
14. AIF Info (check for drain pan recognition: Left F button 1X and down arrow 2X.
15. Print Report to USB
16. Remove USB
17. Oil Quality Support
 - a. Software Version (SVN); hardware (HVN)
 - b. Serial Number
 - c. RTC Date
 - d. RTC Time
 - e. Vat-1
 - f. Vat-2
 - g. Vat-3
 - h. Vat-4
 - i. Vat-5
 - j. Vat-6
 - k. Vat-7
 - l. Vat-8
18. oil quality (OQ) history

SECTION 3. LEVEL 1 PROGRAMMING







Level 1 contains the following:

- Modify product settings
- Set the AIF clock for products
- Perform the Deep Clean procedure
- Fryer Setup Mode

3-1. MODIFYING PRODUCT SETTINGS

1. Press and hold  and  buttons until LEVEL - 1 shows in the display, followed by ENTER CODE.
2. Enter code 1, 2, 3, 4 (first 4 product buttons).
“PRODUCT” and “SELECTN” show in the displays.
3. Press right  button and ‘SELECT PRODUCT’ and “-P 1-” (ex: NUGGETS) show in the displays.

Change Product Names

4. Use the  and  buttons to scroll through 40 products, or press desired product button .
5. Press right  button and the product (ex: NUGGETS) shows in left display and “MODIFY”, and “YES NO” shows in right display. Press  button to change this product, or press the **X** button to choose another product.
6. If  button was pressed, press and release a product button and the flashing letter changes to the first letter under the product button that was pressed. For example, if  pressed, the flashing letter changes to an “A”.

Press same button again and the flashing letter changes to a “B”. Press it again and the flashing letter changes to a “C”. Once desired letter shows in the display, press  button to continue to the next letter and repeat the procedure.

Press and hold the right **X** button to exit Program Mode, or press  button to continue on to “1. COOK TIME”.

To Change Times and Temperatures

7. Press  button until “COOK TIME” shows in display, and then use product buttons  to change the time in minutes and seconds, to a maximum of 59:59.

3-1. MODIFYING PRODUCT SETTINGS (Continued)

8. Press and release ▼ button and “TEMP” shows in the display, along with the preset temperature on the right side of the display.

Press the product buttons  to change the temperature. The temperature range is 190°F (88°C) to 380°F (193°C).

Cook ID Change

9. Press ▼ button until “COOK ID” shows in the display along with the product ID. For example, NUG would be the ID for nuggets. Use the product buttons to change the ID, following the same procedure as Steps 4 thru 6 above.

Alarms (Duty 1 & 2)

10. Press ▼ button until “DUTY 1” shows in left display, and an alarm time in the right display. Press the product buttons  to set an alarm.

Ex., If a Cook Cycle was set at 3 minutes, and an alarm was to go off after 30 seconds into the Cook Cycle, “0:30” would be set in the display at this time. When the timer counts down to 2:30 the alarm sounds.

After alarm time is set, press ▼ button and “DUTY 2” shows in display, and a second alarm can be programmed.

Quality Timer

11. Press ▼ button until QUAL TMR shows in display along with preset holding time. Press product buttons to adjust  hold time (2 hrs., 59 min. max.).

AIF Disable

12. Press ▼ button until “AIF DISABLE” shows in display along with “YES” or “NO”. Using ◀ and ▶ buttons change the display to “YES” if that product is to not be included in the automatic intermittent filtration operation, or “NO” if it is to be included.

Assign Button

13. Press ▼ button until “ASSIGN BTN” shows in the display, along with the product (ex: NUGGETS). If this product already has a product button assigned to it, that LED will be lit. To assign other product buttons to that product, press and hold the product button for 3 seconds and that LED stays lit. To remove a product from a button, press and hold the product button with a lit LED and the LED goes out.



3-2. AIF CLOCK

This feature allows controls to be set for periods of the day that block the automatic “Filter Now” prompts. For example, the controls could be set not interrupt with “Filter Now” prompts during the lunch rush, and during the supper rush. But, if filtering is desired during this time, press and hold a  button to access the filter menu.

Each AIF Blocking period is defined by a start time (a time of day, XX:XX A, etc) and a duration in minutes.

Weekdays M-F are all grouped together. Up to four different AIF blocking periods may be programmed throughout the day for Monday - Friday. (All days share the same settings.)

A separate set of four blocking periods may be programmed for Saturdays, and a final set of four blocking periods may be programmed for Sundays.

1. Press and hold  and  buttons until LEVEL - 1 shows in the display, followed by ENTER CODE.
2. Enter code 1, 2, 3, 4 (first 4 product buttons). “PRODUCT” and “SELECTN” show in the displays.
3. Press ▼ button once and “AIF CLOCK” show in displays.
4. Press √ button and use ◀ and ▶ buttons to scroll through “ENABLE” and “DISABLE” and then press √ button again to select one.
5. If “ENABLE” is chosen, then ▲ and ▼ buttons can be used to scroll through following list of blocking periods:

Left Display	Right Display
M-F 1	XX:XX A XX
M-F 2	XX:XX A XX
M-F 3	XX:XX A XX
M-F 4	XX:XX A XX
SAT 1	XX:XX A XX
SAT 2	XX:XX A XX
SAT 3	XX:XX A XX
SAT 4	XX:XX A XX
SUN 1	XX:XX A XX
SUN 2	XX:XX A XX
SUN 3	XX:XX A XX
SUN 4	XX:XX A XX

3-2. AIF CLOCK
(Continued)

In 12-hour clock mode, there are three items on each line: the start time “XX:XX”, the A or P (am/pm) setting, and the “XX” duration. Use the ◀ and ▶ buttons to set these items, which flashes when the item is selected.

To set a new start time setting, use the product buttons,



to enter the new value.

Press the ▶ button to step over to the AM/PM setting. The A or P can be toggled by pressing the ‘0’ product button.

Press the ▶ button again to step over to the duration value (in minutes). Enter a new value using the product buttons,



NOTICE

In 24-hour clock mode, there are only two items on each line: the time (XX:XX) and the duration (XX). Again, the ◀ and ▶ buttons step you between these items.



Press the right-side X button to exit out of AIF Clock programming mode.

3-3. DEEP CLEAN MODE

This procedure allows a thorough cleaning of the vat by removing caramelized oil from vat. See Section 4-3 in the Operator’s Manual for complete set of instructions.

3-4. FRYER SETUP

This mode has the same settings as seen upon initial start-up of the fryer.

1. Press and hold  and  buttons until LEVEL - 1 shows in the display, followed by ENTER CODE.
2. Enter code 1, 2, 3, 4 (first 4 product buttons). “PRODUCT” and “SELECTN” show in the displays.
3. Press ▼ button 3 times and “FRYER SETUP” show in the displays.
4. Press √ button and *SETUP* *MODE* shows in displays, followed by, “LANGUAGE” on the left display, “ENGLISH” on the right display.

Use ◀ or ▶ buttons to change the operation display to, “FRANCAIS”, “CAN FREN”, “ESPANOL”, “PORTUG”, “DEUTSCHE”, “SVENSKA”, “РУССКИЙ”.

Press ▼ to continue with other set-up items which include:

- TEMP FORMAT - °F or °C
- TIME FORMAT - 12-HR OR 24-HR
- ENTER TIME - Time of day (use product buttons to change)
- ENTER TIME - AM OR PM
- DATE FORMAT - US OR INTERNATIONAL
- ENTER DATE - Today’s date (use product buttons to change)
- FRYER TYPE - GAS or ELEC
- VAT TYPE - FULL OR SPLIT
- DISPOSE BULK OIL - YES/NO (BULK has RTI system)
- SUPPLY BULK OIL - YES/NO (BULK has RTI system)
- DAYLIGHT SAVING TIME - 1.OFF; 2.US (2007 & after); 3.EURO; 4.FSA (US before 2007)
- OIL QUALITY ENABLED (yes or no)
- TPM WARN (value can be set to 0% - 40%)
- TPM MAX (value can be set to 0% - 40%)



Unless otherwise indicated, use ◀ or ▶ to change settings.

SECTION 4. LEVEL 2 PROGRAMMING



Used to access the following:

- Advanced changes to product settings
- Error code log
- Password programming
- Alert Tone/Volume
- No. of cook cycles before filter is suggested
- Automatic filter time



4-1. ADVANCED PRODUCT SETTINGS

1. Press and hold  and  buttons until LEVEL - 2 shows in the display, followed by ENTER CODE.
2. Enter code 1, 2, 3, 4 (first 4 product buttons). “PROD” and “COMP” show in the displays.
3. Press right $\sqrt{}$ button and ‘SELECT PRODUCT’ and “-P 1-” show in the displays.
4. Use the \blacktriangleleft and \blacktriangleright buttons to scroll through 40 products, or press the desired product button.
5. Press right $\sqrt{}$ button and product (ex: NUGGETS) shows in the left display and “MODIFY” “YES NO” shows in the right display. Press the $\sqrt{}$ button to change this product, or press the **X** button to choose another product.

>Load Compensation, Load Compensation Reference, Full Heat, PC Factor<

6. If $\sqrt{}$ button was pressed, “LD COMP” shows in the display along with the load compensation value. This automatically adjusts the time to account for the size and temperature of the cooking load. Press the product buttons  to change this value of 0 to 20.
7. Press \blacktriangledown button until “LCMP REF” shows in the display along with the load compensation average temperature. (if load compensation is set to “OFF”, then “_ _ _” shows in display and setting cannot be programmed) This is the average cooking temperature for each product. The timer speeds up at temperatures above this setting and slows down at temperatures below this setting. Press the product buttons  to change this value.



4-1. ADVANCED PRODUCT SETTINGS (Continued)

8. Press ▼ button until “FULL HT” shows in display along with full heat value in seconds, which means heat is on as soon as a timer button is pressed, for a programmed length of time. Press product buttons  to change this value of 0 to 90 seconds.
9. Press ▼ button until “PC FACTOR” shows in display along with the proportional temperature, which helps keep the oil from over-shooting the setpoint temperature. Press product buttons  to change this value of 0 to 50 degrees.

NOTICE

- Use ▲ button to go back to previous menu items.
- Press X button when finished with the current product, to return to the PRODUCT SELECTN step.
- Press X button a second time to exit PROD COMP mode.

4-2. E-LOG (error code log)



1. Press and hold  and  buttons until LEVEL - 2 shows in the display, followed by ENTER CODE.
2. Enter code 1, 2, 3, 4 (first 4 product buttons). “PROD” and “COMP” show in the displays.
3. Press ▼ button and “E-LOG” shows in the display.
4. Press right √ button and “A” plus the present date & time flashes on the display, along with “*NOW*”.
5. Press ▼ and if an error was recorded, “B” and date, time, and error code information shows in display. This is the latest error code that the controls recorded.
6. Press ▼ and the next latest error code information can be seen. Up to 10 error codes (B to K) can be stored in the E-Log Section.

NOTICE





Press and hold the right √ button to view a brief description of the error.

4-3. PASSWORDS

The 4-digit passwords can be changed for access to Set-Up, Usage, Level 1, Level 2, & Get Mgr.)



1. Press and hold  and  buttons until LEVEL - 2 shows in the display, followed by ENTER CODE.
2. Enter code 1, 2, 3, 4 (first 4 product buttons). “PROD” and “COMP” show in the displays.
3. Press ▼ button twice and “PASSWORD” shows in the display.
4. Press right √ button and “SET UP” shows in display. The Set up password can be changed at this time, or press ▼ once to change the USAGE password, twice for LEVEL 1 password, 3 times for LEVEL 2 password, or 4 times for GET MGR password. And then, follow instructions below.
5. If the password for Set Up Mode (for example) is to be changed, press right √ button and “MODIFY? “YES NO” shows in the display. Press right √ button to change the 4-digit password for the Set Up Mode, using the product buttons .
6. Once new password is entered, “CONFIRM PASSWORD” shows in the display. Press √ button to confirm, or press X to choose another password.

4-4. ALERT TONE (and volume)

1. Press and hold  and  buttons until “LEVEL - 2” shows in the display, followed by “ENTER CODE”.
2. Enter code 1, 2, 3, 4 (first 4 product buttons). “PROD” and “COMP” show in the displays.
3. Press ▼ button 3 times and “ALERT TONE” shows in the display.
4. Press right √ button and “VOLUME” shows in display, along with volume value. Use the product buttons  to set volume from 1 (softest) to 10 (loudest).
5. Once volume is set, press √ button and “TONE” shows in display, along with the tone value. Use the product buttons  to set tone from 50 to 2000 Hz.
6. Press X to exit Alert Tone Mode.



4-5. FILTER AFTER

The number of cook cycles between filtering the oil can easily be programmed for all products.

1. Press and hold  and  buttons until LEVEL - 2 shows in the display, followed by ENTER CODE.
2. Enter code 1, 2, 3, 4 (first 4 product buttons). “PROD” and “COMP” show in the displays.
3. Press ▼ button 4 times and “FILR AFTR” shows in the left display.
4. Use the product buttons  to set the number to cook cycles between filtering procedures from 0 to 99.

4-6. FILTER TIME

The length of time the fryer remains idle between cook cycles before the controls suggest filtering.

1. Press and hold  and  buttons until LEVEL - 2 shows in the display, followed by ENTER CODE.
2. Enter code 1, 2, 3, 4 (first 4 product buttons). “PROD” and “COMP” show in the displays.
3. Press ▼ button 5 times and “FILR TIME” shows in the left display.
4. Use the product buttons  to set a time between cook cycles from 0 to 18:00 hours.



For example, if “5:00” is programmed in the right display, if the vat was not used for 5 hours after a cook cycle, the controls would display “FILR NOW?” “YES NO”.

SECTION 5. LEVEL 3 PROGRAMMING





Used to access the following:

- TECH RESETS-Reset Recovery Faults/Passwords to defaults
- SPCL PROG-Program filter control parameters and other items
- CLOCK SET-Set the time-of-day clock / calendar
- DATA COMM-Data Communications, LonWorks, MMC, etc.
- HEAT CTRL-Program heat algorithm control parameters
- TECH MODE-Control of outputs, display & button tests, etc.
- STATS MODE-Review, reset operating stats, diagnostic logs, etc

5-1. ADDITIONAL ADVANCED PRODUCT SETTINGS

1. Press and hold  and  buttons until LEVEL - 3 shows in the display, followed by ENTER CODE.
2. Enter code 1, 1, 2, 2, 1, 1, 2, 2 (first 2 product buttons), and “A. TECH” & “RESETS” show in the displays.

>Tech Resets<

3. Press right  button and “RECOVERY FAULTS” shows in left display. Right display shows “CLR” and the number of recovery error recorded. Press  button to reset the number to “0”.
4. Press  button and “ALL PASSWORDS RESET” shows in left display. Press  button to reset all passwords set in the controls.

NOTICE

- Use  button to go back to previous menu items.
- Press X button when finished with the current item, to return to the main menu.
- Press X button a second time to exit Level 3 programming.

5-2. SPECIAL PROGRAMMING

The Special Program Mode is used to set more detailed programming, such as:

- SP-1** • ZONE - USA or Non-USA (default setpoints)
- SP-2** • System Initialization
- SP-3** • 2nd Language: English, French, Candian-French, German, Spanish, Portuguese, Swedish, Russian, & NONE
- SP-4** • Quick Configuration - CHKN+FISH; FF/HBR; CHKN; EMPTY
- SP-5** • Polish Duration - X:XX M:SS
- SP-6** • Drain Valve - NORMAL or MANUAL
- SP-7** • Edit S/N (Serial Number)
- SP-8** • Decal Layout - UP/DOWN or DOWN/UP
- SP-9** • Recovery Test Limit - XXX SEC
- SP-10** • Melt Cycle Select - 1.LIQUID; 2.SOLID
- SP-11** • Has Add-Oil Port? - NO PORT; YES PORT
- SP-12** • Change Pad Reminder Time - XX HRS
- SP-13** • Pan Out = Pad Changed Time - XXX SEC
- SP-14** • Auto-Fill Enabled? - YES; NO
- SP-15** • Auto-Fill Cycle Time? - XXX SEC
- SP-16** • Auto-Fill Check JIB - XXX CNT
- SP-17** • Oil Full If Delta Above... - XX°F or C
- SP-18** • Oil Low If Delta Below... - XX°F or C
- SP-19** • Heat Allowed During Fill? - HEAT OK; NO HEAT
- SP-20** • Always Ask "IS POT FILLED?" - YES; NO
- SP-21** • Oil Drain Time - XXX SEC
- SP-22** • Oil WashTime - XXX SEC
- SP-23** • Oil Rinse Time - XXX SEC
- SP-24** • Oil Type Fill Time - XXX SEC
- SP-25** • Repeat Fill Time - XXX SEC
- SP-26** • RTD Air Cooling - X.XX°/SC
- SP-27** • RTD Cold Oil Surround - X.XX°/SC
- SP-28** • RTD Hot Oil Surround - X.XX°/SC
- SP-29** • Temp. Probe x Above Min. - XXX °F or C
- SP-30** • x Above Min. Hit Limit - XXX CNT
- SP-31** • Level RTD Air Cooling - X.XX°/SC
- SP-32** • Level RTD Oil Surround - X.XX°/SC
- SP-33** • New Pad-Max. Fill Time - XXX SEC
- SP-34** • Old Pad-Max. Fill Time - XXX SEC
- SP-35** • Fill To Top Time - XXX SEC
- SP-36** • Reach Top Plus x Seconds - XXX SEC
- SP-37** • Fill Until Pan Empty - XXX SEC
- SP-38** • Valve Auto - Cycle Period - X:XX H:MM
- SP-39** • Refill Detect By.... - LVL PRBS or PRESSURE
- SP-40** • Min. Wash PSI - XX.XX PSI



5-2. SPECIAL PROGRAMMING
(Continued)

- SP-41** • Max. Bubble PSI - XX.XX PSI
- SP-42** • Max. Wash Time - XXXX SEC
- SP-43** • Old Pad Max. Wash Time - XXXX SEC
- SP-44** • Min. Fill Time - XXX SEC
- SP-45** • New Pad Max. Fill Time - XXXX SEC
- SP-46** • Old Pad Max. Fill Time - XXXX SEC
- SP-47** • Required Bubble PSI Hits - XXX CNT
- SP-48** • Pressure Trip Limit - XXX PSI
- SP-49** • Pilot During Filter-PILOT OK or NO PILOT (**GAS FRYERS ONLY**)
- SP-50** • Filling - Low Heat On - XXX SEC
- SP-51** • Filling - Low Heat Off - XXX SEC
- SP-52** • Heat Error Enabled? - YES or NO
- SP-53** • Warm Return Line Enabled?/Interval - H:MM
(Hours/Minutes - OFF to 4 hours)
- SP-54** • Warm Return Line Time - M:SS
(Minutes/Seconds - 0:00 to 4 Minutes)
- SP-55** • Enable R & D Displays? - YES or NO

NOTICE

Not all Special Program Mode functions are discussed in this section. To ensure proper operation of fryer, please consult Henny Penny Corp. before changing any of these settings. For more information on these functions, contact the Service Department at 1-800-417- 8405, or 1-937-456-8405.

To Enter Special Programming:

1. Press and hold  and  buttons until LEVEL - 3 shows in the display, followed by ENTER CODE.
2. Enter code 1, 1, 2, 2, 1, 1, 2, 2 (first 2 product buttons).
3. “A. TECH” & “RESETS” show in displays. Press ▼ and “B. SPCL” & “PROG” show in the displays.

Zone - USA/Non-USA (SP-1)

4. Press √ button and “SP-1 ZONE” shows in the left display. Use ◀ and ▶ buttons to set the default set-points to USA specifications or non-USA specifications.

Initialize System (SP-2)

5. Press ▼ button and “SP-1 DO SYSTEM INIT” scrolls in left display. To reset the controls to factory default settings, press and hold √ button and controls count down “IN 3”, “IN 2”, “IN 1”. Once display shows “-INIT-” & *DONE* the controls are reset to factory defaults.

5-2. SPECIAL PROGRAMMING
(Continued)

2nd Language (SP-3)

5. Press ▼ button and “SP-3 2ND LANGUAGE” scrolls in left display. Use ◀ and ▶ buttons to set to: ENGLISH; FRANCAIS; CAN FREN; ESPANOL; PORTUG; DEUTSHE; SVENSKA; РУССКИЙ or -NONE-.

By setting a second language in the controls, 2 languages can now be easlily chosen by pressing  button twice during normal operation.

One language shows in left display and a second language shows in the right display. Pressing the √ button selects the language in the displays.

Quick Configuration (SP-4)

5. Press ▼ button and “SP-4 QUICK CONFIG” shows in display. Use the ◀ and ▶ buttons to change the menu selection in the controls to: CHKN+FISH; FF/HBR; CHKN or EMPTY.

Polish Duration (SP-5)

6. Press ▼ button and “SP-5 POLISH” shows in left display. Use product buttons  to change polish time, from 5 minutes to a maximum of 10 minutes.

Drain Valve (SP-6)

7. Press ▼ button and “SP-6 DRAIN VALVE” scrolls in the left display. Use the ◀ and ▶ buttons to change the right display to show “NORMAL” or “MANUAL”.

NORMAL means drain valves are controlled electronically and MANUAL means drain valves must be opened by hand.



Edit Unit Serial Number (SP-7)

8. Press ▼ button and “SP-7 S/N √ EDIT” shows in the left display. Press the right √ button to enter the unit’s serial number in the controls, using the product buttons.

“STD” and “CUST” show in the right displays. Press the √ button under “STD” and the first 2 letters of the serial number is the standard equipment code, press X button and a custom equipment code can be entered. THIS SERIAL NUMBER SHOULD MATCH THE SERIAL NUMBER ON THE DATA PLATE, ON THE DOOR.



5-2. SPECIAL PROGRAMMING
(Continued)

Decal Layout (SP-8)

9. Press ▼ button and “SP-8 DECAL LAYOUT?” scrolls in the left display. The words in the right displays should match the arrow type above the  and  buttons.

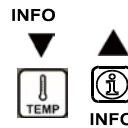

EX: If the control decal shows   the right displays should show DOWN-UP



If the displays show UP-DOWN, use the  and  buttons to change the displays to DOWN-UP.

Liquid or Solid Cooking Oil Used (SP-10)

10. Press ▼ button and “SP-10 MELT CYCLE SELECT” scrolls in the left display. Unless solid oil is being used in the vats the right display should show “1.LIQUID”.

If solid oil is used, the unit MUST BE equipped to handle solid oil. Use the  and  buttons to change the right display to “2.SOLID”

Change Pad Reminder Time (SP-12)

11. Press ▼ button and “SP-12 ‘CHANGE PAD’ REMINDER” shows on the display. Use the product buttons



to change the time between changing the filter pad reminders.

For example, if “25 HRS” is programmed in the right display, every 25 hours the display shows “CHANGE PAD” as a reminder to the operator that the filter pad needs changed.

Pan Out of Fryer = Pad Changed (SP-13)

12. Press ▼ button and “SP-13 PAN OUT = CHANGED PAD” scrolls in the left display. Use the product buttons



to program amount of time the drain pan is pulled-out from under fryer before the controls reset the change pad reminder. This is the amount of time it should take to change filter pad. The range is 15 to 255 seconds.





For example, if “120 SEC” is programmed in the right display, when the drain pan is out from under the fryer for at least 120 seconds, the controls restarts counting for the change pad reminder.

Auto-Fill Enabled (SP-14)(automatically keeps oil at proper level)

13. Press ▼ button and “SP-14 AUTO-FILL ENABLED?” scrolls in the left display. Use the  and  buttons to set the right display to “YES” or “NO”.

This should always be set to “YES”, unless a hardware failure causes a problem, such as a JIB pump or Add Oil valve failure.

5-3. CLOCK SET

1. Press and hold  and  buttons until LEVEL - 3 shows in the display, followed by ENTER CODE.
2. Enter code 1, 1, 2, 2, 1, 1, 2, 2 (first 2 product buttons).
3. “A. TECH” & “RESETS” show in displays. Press ▼ button twice and “C. CLOCK” and “SET” show in the displays.
4. Press √ button and “CS-1 ENTER DATE MM-DD-YY” shows in the left display. Use the product buttons  to set the date in right display.
5. Press ▼ button and “CS-2 ENTER TIME” shows in left display and time flashes in right display. Use product buttons  to change the time.
6. Press ▼ button and “CS-2 ENTER TIME” shows in left display and “AM” or “PM” flashes in right display. Use the ◀ ▶ buttons to change from AM to PM or vice-versa.
7. Press ▼ button and “CS-3 TIME FORMAT” shows in left display and “12-HR” or “24-HR” shows in right display. Use the ◀ ▶ buttons to change from a 12 hour time format to a 24 hour time format or vice-versa.
8. Press ▼ button and “CS-4 DAYLIGHT SAVING TIME” shows in the left display. Use the ◀ ▶ to change daylight saving time for your area: 1.OFF; 2.US (2007 & after); 3.EURO; or 4.FSA (US before 2007)

5-4. DATA COMM & HEAT CONTROL

NOTICE

Data communications and heat controls settings are shown in Level 3 Program Mode. But, to ensure proper operation of fryer, please consult Henny Penny Corp. before changing any of these settings. For more information on these functions, contact the Service Department at 1-800-417-8405, or 1-937-456-8405.

5-5. TECH MODE







The TECH Mode has self-diagnostic information, which can be used by certified technicians for troubleshooting purposes, such as:

- T-1** • Software
- T-2** • Fryer Type (Gas or Elec.)
- T-3** • Push Button Test
- T-4** • All On Display Test
- T-5** • Display Segments Test
- T-6** • Display Digits Test
- T-7** • Display Decimal Points Test
- T-8** • LED's Test
- T-9** • Left Temp. Probe Calibration & Offset
- T-10** • Left Level 1 Probe Calibration & Offset
- T-11** • Left Level 2 Probe Calibration & Offset
- T-12** • Right Temp. Probe Calibration & Offset
- T-13** • Right Level 1 Probe Calibration & Offset
- T-14** • Right Level 2 Probe Calibration & Offset
- T-15** • CPU Control Temp. Calibration/Offset/Highest
- T-16** • View A - D Channel
- T-17** • Digital Inputs
- T-18** • AIF Info
- T-19** • Outputs Test
- T-20** • Pumps & Valves Test
- T-21** • Change Tech Code?
- T-22** • Total Initialization

NOTICE

Not all Tech Mode functions are discussed in this section. To ensure proper operation of fryer, please consult Henny Penny Corp. before changing any of these settings. For more information on these functions, contact the Service Department at 1-800-417- 8405, or 1-937-456-8405.



5-5. TECH MODE (Continued)

1. To enter the TECH Mode, press and hold  and  buttons for 5 seconds, until display shows "LEVEL 3", followed by "ENTER CODE".
2. Enter code 1, 1, 2, 2, 1, 1, 2, 2 (first 2 product buttons). "A. TECH" & "RESETS" show in the displays.
3. Press  5 times, and when display shows "F. TECH", press the right  button and T-1 "SOFTWARE" shows in the display, the first step of the TECH Mode. Use  and  buttons to toggle through the steps.

NOTICE

Press the right **X** button twice, at anytime to return to normal operation.

T-1 - SOFTWARE

- Press  to view HP Part No. of eprom
- Press  to view software ID
- Press  to view software version

T-2 - FRYER TYPE - GAS or ELEC

T-3 - PUSH-BUTTON TEST

Press any of the control buttons to test operation. You should hear a beep, and the LED should light and/or a display.

T-4 - ALL-ON DISPLAY TEST

Press any of the product buttons and all the LEDs and display segments should light.

T-5 - SEGMENTS TEST

Press any of the product buttons to view a different segment of the display characters.

T-6 - DIGITS TEST

Press any of the product buttons numerous times to view all segments of each digit across the displays.

T-7 - DECIMAL PTS TEST

Press any of the product buttons numerous times to view all decimal points across the displays.

5-5. TECH MODE (Continued)

T-8 - DECIMAL PTS TEST

Press any of the product buttons numerous times to view each LED across the control panel.

T-17 - DIGITAL INPUTS - HDF

H = HIGH LIMIT - If “H” is present, the high limit is good. If “-” shows then the high limit is tripped out (overheated) or disconnected.

D = DRAIN SWITCH - If “D” is present, the drain handle (when applicable) is closed. If “-” shows then the drain is open or the switch is faulty.

F = FAN (PRESSURE SWITCH) - If “F” is present, the pressure switch is good. If “-” shows in the display, the switch is faulty.

Press  button and an underscore (“_”) indicates the input is not presently detected. A Checkmark (“√”) indicates the signal is detecting a normal input. A blinking (“X”) indicates the signal is presently detected, but is detected as a half-wave (partially failed) input.

NOTICE

The H, D, F signals above are wired in series. The first signal missing out of this sequence I generally causes all signals to the right of it to be missing as well.

T-18 - AIF INFO (AIF PCB communicating with control PCB?)

An “AIF √” means normal communications between the AIF PCB and the control PCB. “AIF X” means a problem with the communications between the PCBs.

Press  button and “FILR IN” and “USE BY 1(ex)” shows in the displays. These displays shows which controls are using the filtering system.

“USE BY 0” = not in use

“USE BY 7” = used by AIF

“USE BY 1 to 5” = used by control PCB

Press  button and “CPU POSN” and “1 OF 3(ex)” shows in the displays. These displays shows which controls are plugged into which port on the AIF board.

For example, the left control should be plugged into port 1, and on a 3 control fryer, shows “1 OF 3” on the display.

If the right control is unplugged, then the left control would show “1 OF 2” instead of “1 OF 3”.

5-5. TECH MODE (Continued)

Press ▼ button and “INP E_P_” and “JL_R_DF_” shows in the displays.

AIF Board Inputs:

E = Stop button	E* = E-Stop pressed.
P = Drain Pan	M* = drain pan is missing.
JL = JIB	J* = JIB oil level is low.
R = RTI	R* = RTI System Detected
DF = RTI Discard Tank	DF* = tank full

Press ▼ button and “OUT F_J_” and “N_DI_JFo” shows in the displays.

AIF Board Outputs:

Current outputs status from AIF board.

F = Filter Pump.	(F* = Filter pump is on)
J = JIB Pump.	(J* = JIB pump is on)
N = New Oil Pump.	(N* = RTI new oil pump on)
DI = Discard Valve.	(DIo = RTI disc. valve open/DIc=closed)
JF = JIB Fill Valve.	(JFo = RTI JIB fill valve open/ JFc=closed)

Press ▼ button and “REQ F_J_” and “N_DI_JFo_” shows in the displays.



AIF Board Outputs Requested by the Control Board:



Current outputs status from AIF board.



F = Filter Pump.	(F* = Filter pump is on)
J = JIB Pump.	(J* = JIB pump is on)
N = New Oil Pump.	(N* = RTI new oil pump on)
DI = Discard Valve.	(DIo = RTI disc. valve open/ DIc=closed))
JF = JIB Fill Valve.	(JFo = RTI JIB fill valve open/ JFc=closed)

T-19 - OUTPUTS

F = FAN (PRESSURE SWITCH)- Press  or  to open and close the pressure switches

S = SAFETY GAS VALVE (if available) - Press  or  to open and close the gas safety valves

I = IGNITION MODULE - Press  or  to open and close the outputs on the ignition modules

H = HEAT OUTPUTS - Press  or  to turn on and off the heating outputs (ex: gas valve)

5-5. TECH MODE (Continued)

T-20 - PUMPS & VALVES

Press  button and “VALVES” “DcRcAc” shows in displays.

Press  to open and close the drain valves.

Press  to open and close the return valves.

Press  to open and close the add valves.

“DcRcAc” means valves are closed, “DoRoAo” means valves are open. (Driven by the control board)

Press  button and “DISCARDc” and “JIBFILLc” shows in the displays. (Driven by the AIF board)

Press  to open and close the RTI discard valve (display shows “DISCARDo” when open)

Press  to open and close the RTI JIB fill valve (display shows “JIBFILLo” when open)

Press  button and “PUMP FP_” and “JP_ NP_” shows in the displays. (Driven by the AIF board)

Press  to turn off and on the filter pump (display shows “FP*” when on)

Press  to turn off and on the JIB pump (display shows “JP*” when on)

Press  to turn off and on the RTI new oil pump (display shows “NP*” when on)



Press  button and “LIGHTS” and “FLT_ JLO_” shows in the displays. (Driven by the AIF board)

Press  to turn off and on the FILTER light (display shows “FLT*” when on)

Press  to turn off and on the JIB LOW light (display shows “JLO*” when on)

5-6. STATS MODE

This mode allows a technician to view advanced information on the operation of the fryer and controls.

1. To enter the TECH Mode, press and hold  and  buttons for 5 seconds, until display shows "LEVEL 3", followed by "ENTER CODE".
2. Enter code 1, 1, 2, 2, 1, 1, 2, 2 (first 2 product buttons). "A. TECH" & "RESETS" show in the displays.
3. Press ▼ 6 times, and when display shows "G. STATS", press the right √ button and "ST-1 LAST RESET ON..." shows in display, the first step of the TECH Mode. Use ▼ and ▲ buttons to toggle through the steps.

- ST-1** • Stats Last Reset Date
- ST-2** • Fryer Total Running Hours
- ST-3** • Left Vat Melt Cycle Hours
- ST-4** • Left Vat Cook Cycle Hours
- ST-5** • Left Vat Filter Lockout Hours
- ST-6** • Right Vat Melt Cycle Hours
- ST-7** • Right Vat Cook Cycle Hours
- ST-8** • Right Vat Filter Lockout Hours
- ST-9** • Power-Ups Count
- ST-10** • Error Counts
- ST-11** • Left Vat Heat On Hours
- ST-12** • Right Vat Heat On Hours
- ST-13** • Highest Left Vat Oil Temperature
- ST-14** • Highest Right Vat Oil Temperature
- ST-15** • Highest CPU Temperature
- ST-16** • System RAM Fade Count
- ST-17** • Cook RAM Fade Count
- ST-18** • Product RAM Fade Count
- ST-19** • Stat RAM Fade Count
- ST-20** • RAM Data Error Count
- ST-21** • Data Total Loss Count
- ST-22** • User Initialization Count
- ST-23** • Automatic Initialization Count
- ST-24** • Cooks Count per Product
- ST-25** • Cook Cycle Stop Counts
 - "A" = number of stops in the first 30 seconds
 - "B" = 0
 - "C" = 0
 - "D" = complete cook cycles counted
- ST-26** • Reset All Stats

SECTION 6. INFORMATION MODE

6-1. INFO MODE

This mode gathers and stores historic information on the fryer and operator’s performance. Press and hold  for 3 seconds, until *INFO* *MODE**” shows on the displays.

Press ▼ or ▲ buttons to access the steps and press √ button to view the statistics within each step.

This mode includes the following information:

1. **FILTER STATS** - filtering information for the last 7 days
2. **REVIEW USAGE**- information accumulated since the last time this data was manually reset
3. **LAST LOAD** - information about the most recent Cook Cycle, or the cycle presently in progress

NOTICE

Press X button to exit from the Information Mode.

1. FILTER STATS

Press √ button to select Filter Stats and then press ◀ and ▶ to select the day for which you want to view the stats. Then press ▼ or ▲ buttons to view the following stats:

- “FILTERED” = No. of times filtered
- “FLT BPSD” = No. of times filtering was skipped
- “FLT AVG” = Average no. of cook cycles between filters

2. REVIEW USAGE

Press √ button to select Review Usage and press ▼ or ▲ buttons to view the following:

FUNCTION	DISPLAY EX:
Day usage data was previously reset	SINCE 9:32P 04-19-10
Total number of cook cycles	TOTAL COOKS 462
Cook Cycles stopped before “PULL”	QUIT COOK 4
Number of hours fryer was on (left)	L ON HRS 165
Number of hours fryer was on (right)	R ON HRS 160

6-1. INFO MODE
(Continued)

3. LAST LOAD

Press √ button to select Last Load (ex: -P1- = Product 1; "L1" = left, 1st product) and press ▼ or ▲ buttons to view the following:

FUNCTION	DISPLAY EX:
Product (Last product cooked)	PRODUCT -P1- L1
Time of day last Cook Cycle was started	STARTED 10.25A SEP-08
Actual Elapsed cook Time (Real seconds)	ACTUAL TIME 7:38
Programmed cook Time	PROG TIME 3:00
Max Temp during Cook Cycle	MAX TEMP 327°F
Min Temp during Cook Cycle	MIN TEMP 313°F
Avg Temp during Cook Cycle	AVG TEMP 322°F
Heat On (percentage) during Cook Cycle	HEAT ON 73%
Ready? (Was fryer Ready before start?)	READY? YES

SECTION 7. MAINTENANCE

7-1. PREVENTIVE MAINTENANCE

To ensure a long life of fryers and their components, regular maintenance should be performed. Refer to the chart below.

Frequency	Action
Daily	Maintenance Filter (See Maintenance Filtering Instructions Section in Operator's Manual or PM Guide)
Daily	Change Filter Pad (See Changing Filter Pad Section in Operator's Manual or PM Guide)
Weekly	Clean Behind Fryer (See PM Guide)
Quarterly	Change Filter Pan O-Rings (See PM Guide)
Quarterly	Vat Deep Clean (See Deep Clean Mode Section in Operator's Manual or PM Guide)
Quarterly	Clean Blower Motors (See PM Guide)

7-2. OIL CHANNEL CLEAN-OUT

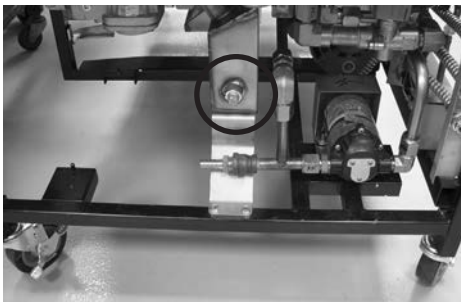

Should the drain channel, under the vats, become clogged, access to a clean-out plug is available on both right and left sides of the unit.

**7-3. CONTROL PANEL &
MENU CARD
REPLACEMENT**

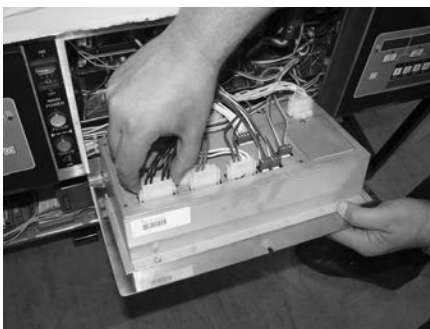
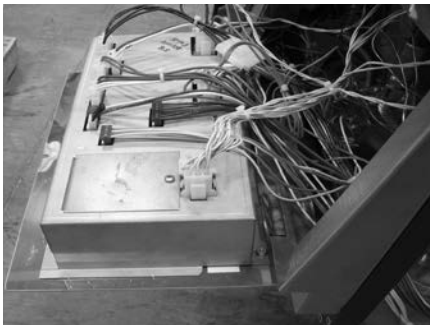
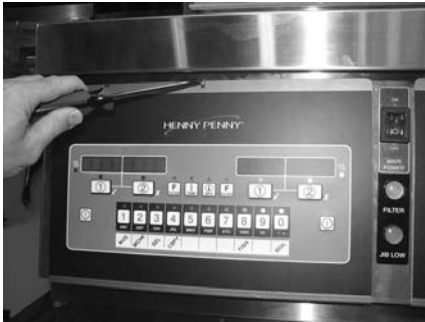

Should the control panel become inoperative, or the menu card needs changed, follow these instructions:

1. Remove electrical power supplied to the vat.



To avoid electrical shock or property damage, move the power switch to OFF and disconnect main circuit breaker, or unplug cord at wall receptacle.

2. Loosen the screw securing the top of the control panel.

3. Pull the top of the panel down, allowing the panel to be supported by 2 brackets in the slots in the control shroud. (If changing control panel, continue onto step 5.)

4. If changing the menu card, loosen the tape securing menu card at the bottom, side of control panel and pull menu card from panel. Carefully, slide changed menu card back into slot in panel and secure with tape.

5. Unplug the connectors going to the control board.

6. Install a new control panel in reverse order.

7. Restore power to the unit. Turn unit on and follow prompts in the Set-up Mode. See paragraph 3-4 for more details.

7-4. HIGH TEMPERATURE LIMIT CONTROL



This is a safety, manual reset control, which senses the temperature of the oil. If the oil temperature exceeds 425°F (218°C), this switch opens and shuts off the heat to the vat and “E-10” shows in the display. When the temperature of the oil drops to a safe operation limit (15-20 minutes), manually reset the control by pressing the red reset button.

The red reset button is located behind the doors, underneath the controls; find the appropriate high limit and press the red reset button; if high limit does not reset, high limit must be replaced; If high limit resets, the oil starts heating.

Checkout:

Before replacing a high temperature limit control, check to see that its circuit is closed.

NOTICE

Oil temperature must be below 380°F (193°C) to accurately perform this check.

1. Remove electrical power supplied to the fryer.



To avoid electrical shock or property damage, move power switch to OFF and disconnect main circuit breaker, or unplug cord at wall receptacle.

2. Using a Phillip's-head screwdriver, or cordless drill, loosen screw securing the top of control panel and secure control panel in the slots of the shroud.
3. Open the front door, and using a 3/8" socket or nut-driver, remove the 2 nuts securing the high limit bracket to the unit.
4. Pull high limit and bracket from inside of control panel and remove the two screws securing the high limit to the bracket.
5. Pull high limit from bracket, pull back the cardboard protector, and remove two electrical wires from high limit control.
6. Manually reset control, then check for continuity between the two terminals after resetting control. If circuit is open, replace control, then continue with this procedure. (If circuit is closed, high limit is not defective. Reconnect the two electrical wires.)

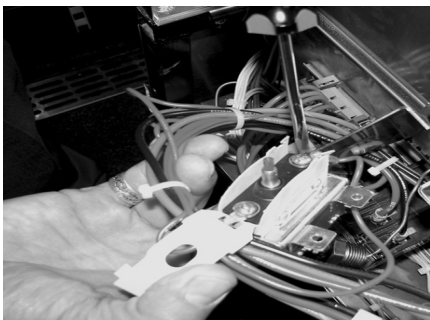
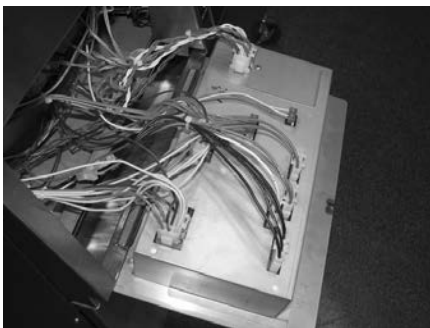

**7-4. HIGH TEMPERATURE
LIMIT CONTROL
(Continued)**

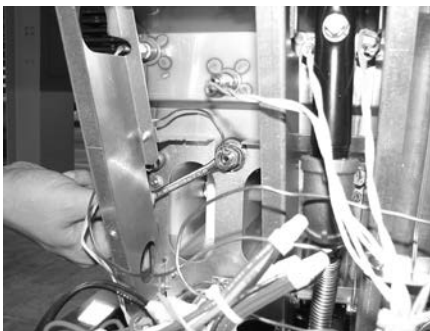
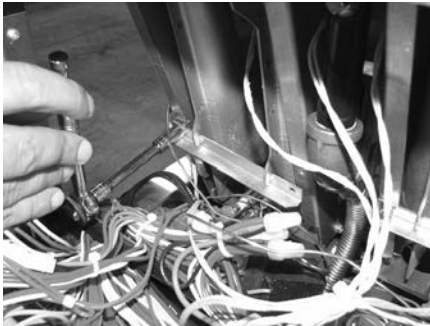

Replacement:

If the tube is broken or cracked, the control opens, shutting off electrical power. The control cannot be reset.

1. Drain the oil from the vat, by pressing and holding a  button until *FILTER* *MENU* shows in the display. Then once "1.AUTO FILTER" shows in the display, press ▼ 3 times until "4.DRAIN TO PAN" shows in the display. Press √ button and "DRAIN TO PAN" "YES NO" shows in the display. Press √ button again, display shows "DRAINING", and oil drains from vat. Once oil has drained, display shows "VAT EMPTY" "YES NO". Visually check that vat is empty and press √ button, display shows "DRAIN CLOSING..." and drain closes.

2. Remove electrical power supplied to the fryer.



To avoid electrical shock or property damage, move the power switch to OFF and disconnect main circuit breaker, or unplug cord at wall receptacle.

3. Using a 3/8" socket, remove 2 screws securing the burner jet bracket and remove bracket.
4. Pull both burner jets from unit.
5. Using a 5/16" wrench, loosen small inside screw nut on capillary tube.
6. Using a Phillip's-head screwdriver, remove the 2 screws the capillary bulb bracket and pull bracket from unit.
7. Using an 11/16" crows-foot remove the large high limit fitting vat wall, and pull the high limit from inside the control area.

**7-4. HIGH TEMPERATURE
LIMIT CONTROL
(Continued)**



7. Using an 11/16" crows-foot, remove large high limit fitting in vat wall, and pull high limit from inside the control area.
8. Install new high limit in reverse order and restore power to unit.
9. Fill vat by pressing and holding a  button until *FILTER* *MENU* shows in the display. Then once "1.AUTO FILTER" shows in the display, press ▼ 4 times until "5.FILL POT FROM DRN PAN" shows in display. Press √ button; "FILL POT FROM DRN PAN" "YES NO" displays. Press √ button again, display shows "FILLING" "STOP?" and oil fills vat. Press √ button again, display shows "FILL POT FROM DRN PAN" "YES NO". When vat is full, press X twice to return to normal operation.

7-5. MAIN POWER SWITCH

This is a covered rocker switch, which in the ON position, sends power to all the controls and filter motor.



To avoid electrical shock or property damage, move the power switch to OFF and disconnect main circuit breaker, or unplug cord at wall receptacle.



1. Remove control panel.
2. From the inside of control area, squeeze in on the tabs on the back of the switch and push switch out the front of the control area.
3. Label and remove wires from the switch.

Checkout:

4. Check across the two sets of terminals of the switch for continuity. With switch in the ON position, circuit should be closed. With switch in the OFF position, circuit should be open.

If the switch is found to be defective, replace it by connecting the wires to it (as labeled) and push new switch into place.

7-6. PROBE REPLACEMENT



Oil level probe Temperature probe Oil level probe

The temperature probe is the center probe inside the vat (see photo at left) and it relays the actual oil temperature to the control. If it becomes disabled, “E-6A or B” shows in the display.

The oil level probes (left & right-see photo at left) monitor the oil level by temperature differences. If they become disabled, the display shows: “E-18A”= left probe; “E18-B”= right probe; “E18C”= both.

Also, if any of the probes are out of calibration more than 5°F, or 5°C, the probe should be replaced. An Ohm check can be performed also. See chart below.

Checkout:



To avoid electrical shock or property damage, move the power switch to OFF and disconnect main circuit breaker, or unplug cord at wall receptacle.

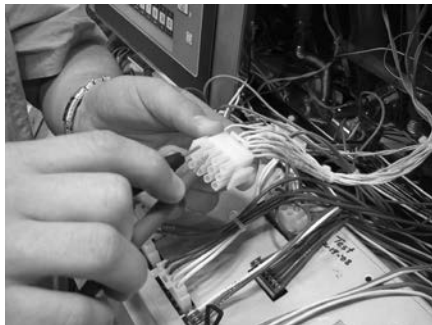

1. Using a Phillip’s-head screwdriver, or cordless drill, loosen the screw securing top of control panel and secure control panel in the slots of the shroud.
2. Pull the probe connector from control panel and locate the terminals in the connector for probe being tested. Attach meter leads onto those terminals and refer to chart at left to determine if probe is good or not. (Probe wires are labeled, with #1 being the far left probe.)

Temp. F	Temp. C	Resistance Ohms	Temp. F	Temp. C	Resistance Ohms
50	10.00	1039.02	250	121.11	1464.79
60	15.56	1060.65	260	126.67	1485.71
70	21.11	1082.24	270	132.22	1506.58
80	26.67	1103.80	280	137.78	1527.43
90	32.22	1125.32	290	143.33	1548.23
100	37.78	1146.81	300	148.89	1569.00
110	43.33	1168.26	310	154.44	1589.73
120	48.89	1189.67	320	160.00	1610.43
130	54.44	1211.05	325	162.78	1620.77
140	60.00	1232.39	330	165.56	1631.09
150	65.56	1253.70	340	171.11	1651.72
160	71.11	1274.97	350	176.67	1672.31
170	76.67	1296.20	360	182.22	1692.86
180	82.22	1317.40	365	185.00	1703.13
185	85.00	1327.99	370	187.78	1713.38
190	87.78	1338.57	380	193.33	1733.87
200	93.33	1359.69	390	198.89	1754.31
210	98.89	1380.79	400	204.44	1774.72
212	100.00	1385.00	410	210.00	1795.10
220	104.44	1401.84	420	215.56	1815.44
230	110.00	1422.86	430	221.11	1835.74
240	115.56	1443.85	440	226.67	1856.01

Replacement:

1. Reattach control panel to unit and restore power to the unit.
2. Drain oil from the vat, by pressing and holding a **F** button until *FILTER* *MENU* shows in the display. Then once “1.AUTO FILTER” shows in the display, press ▼ 3 times until “4.DRAIN TO PAN” shows in display. Press √ button and “DRAIN TO PAN” “YES NO” shows in the display. Press √ button again, display shows “DRAINING”, and oil drains from vat. Once oil has drained, display shows “VAT EMPTY” “YES NO”. Visually check that vat is empty and press √ button, display shows “DRAIN CLOSING...” and drain closes.

**7-6. TEMPERATURE PROBE
REPLACEMENT
(Continued)**



To avoid electrical shock or property damage, move the power switch to OFF and disconnect main circuit breaker, or unplug cord at wall receptacle.

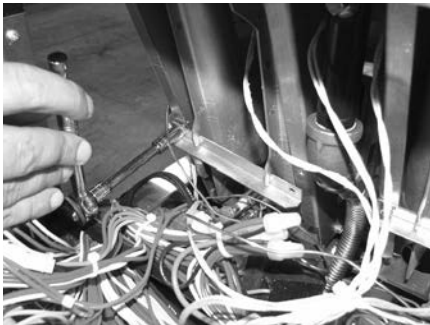

3. Using a 3/8" socket, remove 2 screws securing the burner jet bracket and remove bracket.

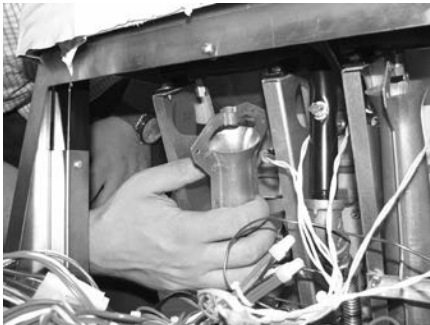

4. Pull both burner jets from unit.

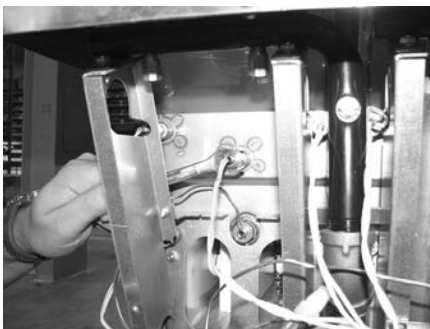

5. Using a 1/2" wrench, remove nut on compression fitting, and remove the temperature probe from the vat.

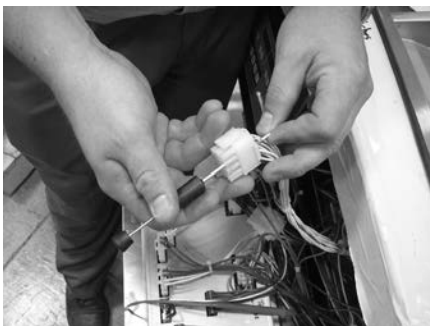

6. Using terminal extractor, remove probe terminals from connector and remove probe from unit.

**7-6. TEMPERATURE PROBE
REPLACEMENT
(Continued)**

- Place nut and new ferrule on the new temperature probe and insert temperature probe into the compression fitting. See drawing below.

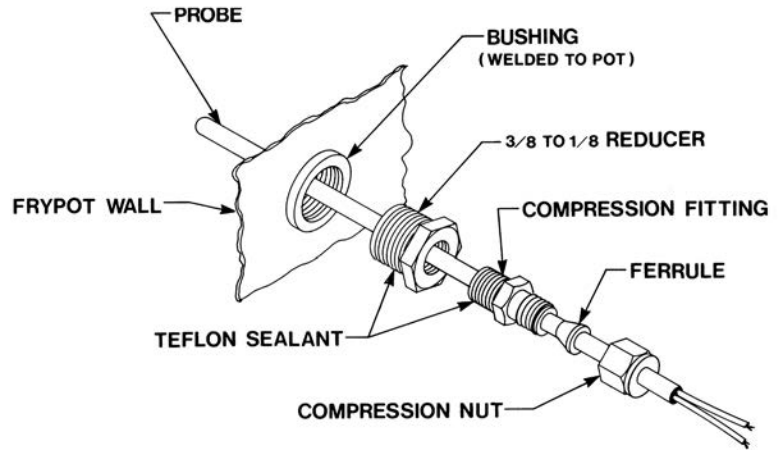

- Using the probe gauge in the kit, follow the instructions on drawing below.
- Hand-tighten compression nut and then a half turn with wrench.



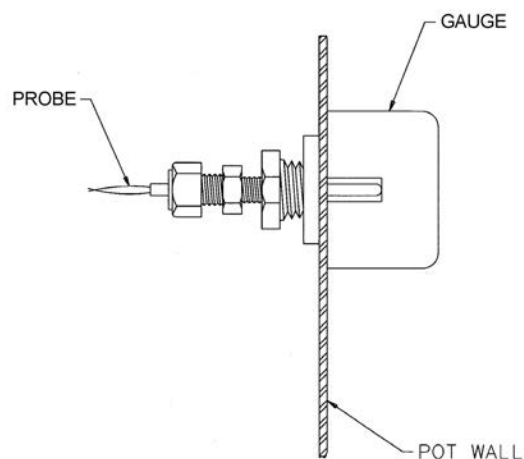

CAUTION

Excess force will damage temperature probe.



- NOTE:
- LOCATE TEMPERATURE PROBE THRU POT WALL.
 - PLACE GAUGE AGAINST POT WALL AS SHOWN.
 - PUSH TEMPERATURE PROBE THRU UNTIL IT MAKES CONTACT WITH GAUGE.
 - TIGHTEN TEMPERATURE PROBE IN PLACE.

**7-6. TEMPERATURE PROBE
REPLACEMENT
(Continued)**

8. Connect new temperature probe to connector and fasten connector onto control panel.
9. Replace control panel and reconnect power to vat.
10. Fill vat by pressing and holding a  button until *FILTER* *MENU* shows in the display. Then once "1.AUTO FILTER" shows in the display, press  4 times until "5.FILL POT FROM DRN PAN" shows in display. Press  button; "FILL POT FROM DRN PAN" "YES NO" displays. Press  button again, display shows "FILLING" "STOP?" and oil fills vat. Press  button again, display shows "FILL POT FROM DRN PAN" "YES NO". When vat is full, press **X** twice to return to normal operation.

7-7. SOLENOID VALVES

Each vat has a solenoid plumbed-into the oil return lines. They are normally closed, but open when power is supplied, such as, the controls are filling the vats.



To avoid electrical shock or property damage, move the power switch to OFF and disconnect main circuit breaker, or unplug cord at wall receptacle.

1. Remove both top and bottom rear panels, or a side panel, depending upon the location of the solenoid.

Checkout:

2. Follow the wires from solenoid and through conduit and then cut wires. Strip wires back and take an ohm reading:

120 Volts - 60Hertz	50 Ohms
220-240 Volts -50/60 Hertz	230 Ohms



7-7. SOLENOID VALVES (Continued)



Replacement:

1. Using a 1 in. wrench, loosen the front and rear fittings to solenoid.

2. Remove the conduit from the fryer and pull the solenoid assembly from the fryer.

3. Remove the conduit from the solenoid.

7-7. SOLENOID VALVES
(Continued)

4. Remove elbow and fittings from solenoid stem assembly, and attach them to new solenoid, using pipe sealent on the threads.
5. Reattach the conduit to new solenoid, threading the wires through the conduit.
6. Reattach the solenoid assembly to the fryer.
7. Reattach the conduit to fryer and connect the wires to the fryer using wire nuts.
8. Replace rear side panels or rear panels and reconnect power to the fryer.

7-8. DRAIN VALVE
ACTUATORS

Each vat drain valve is opened and closed by an actuator, so if the oil won't drain or pump back into the vat, the actuator may be faulty.

Replacement:



To avoid electrical shock or property damage, move the power switch to OFF and disconnect main circuit breaker, or unplug cord at wall receptacle.

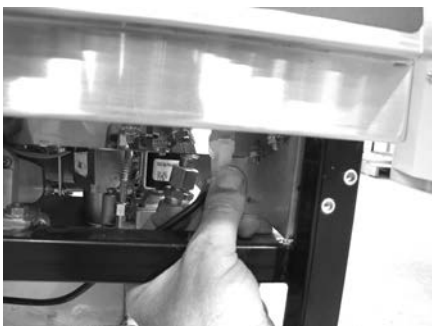

1. Access faulty actuator by removing a side panel or opening doors, depending upon the location of the actuator.
2. Push-out the retaining pins in the front and rear of actuator.
3. Disconnect the wires.
4. Install new actuator in reverse order, and reconnect power to the fryer.

7-9. FILTER PUMP & MOTOR

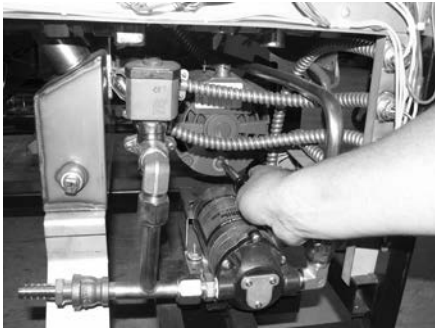

The 2 most common causes for a fryer not to pump oil are that the pump is clogged, or the thermal overload switch has been tripped on the motor. The pump and motor is located on the rear of the fryer.

To reset the thermal overload switch:

1. Remove the right side panel and locate pump and motor in the rear of the fryer. If the motor is hot, allow it to cool for about 5 minutes.
2. Since it takes some effort to reset the switch, use a tool, such as a Phillip's-head screwdriver, to press against the reset button until a "click" is heard.

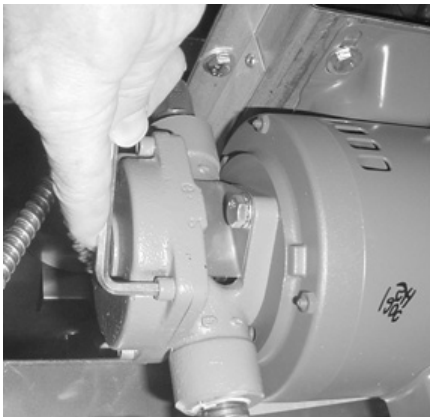

To remove debris from pump:

1. Loosen four Allen head screws on the end of pump and remove cover. (Removing the bottom rear panel may help in accessing the set screws.)
2. The inside is now exposed leaving a rotor and five teflon rollers. Clean the rotor and rollers.
3. To reassemble, place rotor on drive shaft, and place roller into rotor.

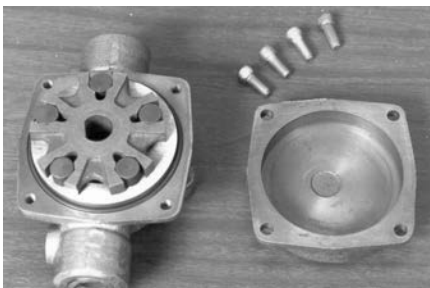

NOTICE

A small amount of grease might be needed to hold the bottom roller into place until cover plate is put on. Make sure O-ring is in proper position on plate.

CAUTION

Indicators, on the side of the two halves of the pump, must align together.

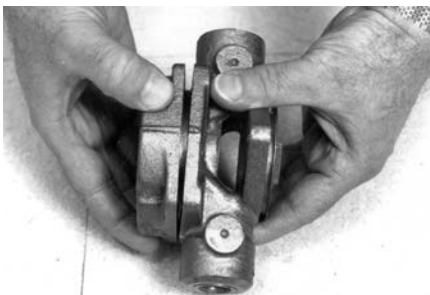

7-9. FILTER PUMP & MOTOR **(Continued)**



To avoid electrical shock or property damage, move the power switch to OFF and disconnect main circuit breaker, or unplug cord at wall receptacle.

Removal:

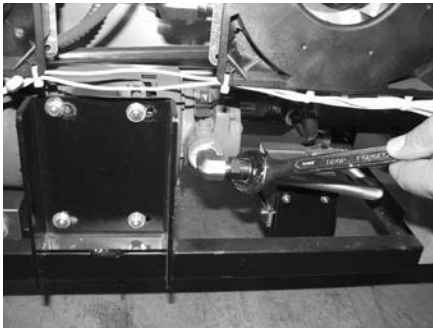

1. Remove the bottom, rear panel and the right side panel.
2. Using a 5/8" wrench, loosen the front, flexible line fitting, on the pump.
3. Using a 1" wrench, loosen the rear pump fitting.
4. Locate the appropriate conduit on right side of the unit and disconnect the conduit from the fryer.
5. Using a 1/2 in. wrench, remove 4 bolts securing motor to motor bracket and pull pump and motor assembly from fryer.

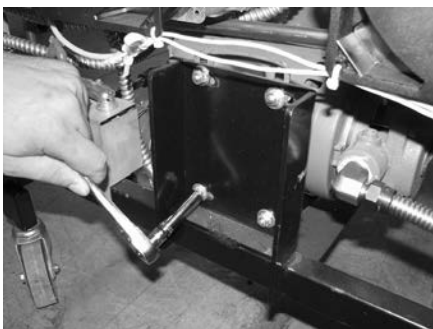

To replace pump on motor:

1. Using a 1/2 in. wrench, remove the 2 bolts securing pump to the motor and pull the pump from the motor.
2. Install a new seal kit (part no. 17476) onto shaft of motor.
3. Align the shaft of motor with the rotor on the inside of the pump and push pump onto shaft of motor.
4. Secure the pump onto the motor with the 2 bolts.

7-10. AIF PUMP

This pump keeps the vats filled and is used in the Automatic Intermittent Filter process.

Replacement:



To avoid electrical shock or property damage, move the power switch to OFF and disconnect main circuit breaker, or unplug cord at wall receptacle.

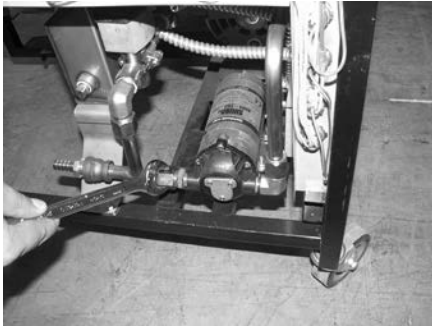

1. Remove the right side panel.
2. Using 1" wrench, loosen both fitting on each side of pump.
3. Using a Phillip's-head screwdriver, remove the 4 screws securing the bottom of pump.
4. Disconnect the wires in the rear of the pump and pull assembly from fryer.
5. Pull fittings from faulty pump and attach fittings to the new pump, in the same orientation.
6. Install new pump assembly in fryer, in reverse order and then reconnect power to fryer.

7-11. AIF PC BOARD

This electronic board controls the Automatic Intermittent Filtering process.

Replacement:



To avoid electrical shock or property damage, move the power switch to OFF and disconnect main circuit breaker, or unplug cord at wall receptacle.

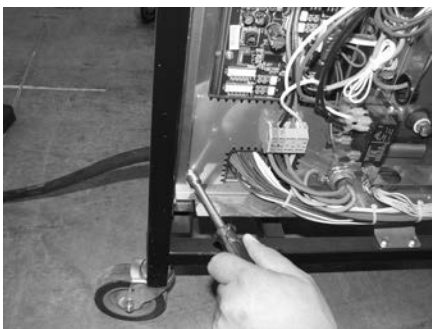

1. Remove the left side panel.
2. Using a 3/8" socket or nut driver, remove nuts securing the cover and remove cover.
3. Pull connectors from PC board.
4. Using a 5/16" socket, remove 6 nuts securing the board and remove it from the fryer.
5. Install in reverse order. The control connectors are colored-coded; Left-Red; Middle-White; Right-Blue.

7-12. TRANSFORMERS

These components drop the line voltage to low voltage components such as, control board, AIF board and gas valves.

Checkout:

1. Perform Power Section troubleshooting, paragraph 1-3.



To avoid electrical shock or property damage, move power switch to OFF and disconnect main circuit breaker, or unplug cord at wall receptacle.

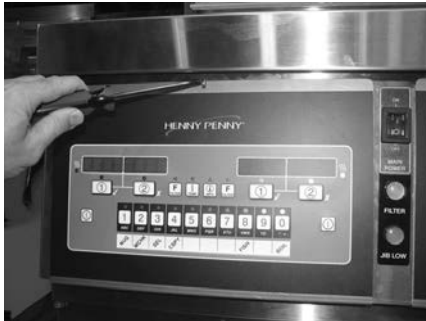

2. Loosen the screw securing the top of the control panel.
3. Pivot the top of the panel down, allowing panel to be supported by 2 brackets in the slots in control shroud.



To avoid electrical shock, use care when checking transformer. Following checks are performed with wall circuit breaker closed and main power switch in the ON position.

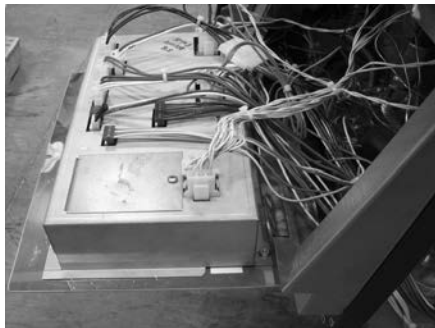

4. Remove 3 pin connector (P2) from back of control panel.
5. Set multi-meter to AC volts. With power ON, take voltage reading on 2 outside pins. Voltage should be 120VAC-Dom. or 230VAC-Int'l. If no voltage, perform step 1.

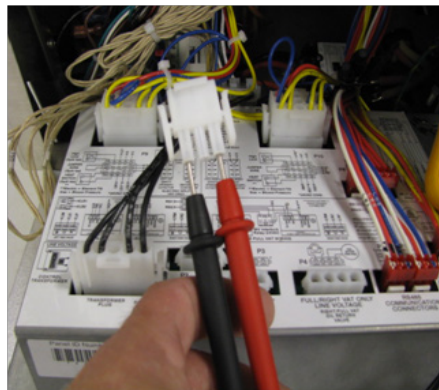

6. Reconnect 3 pin connector to the back of control panel.
7. With power ON and 5 pin connector (P1) still connected, insert meter probes into back of P1 at positions 4 and 5. Voltage should be 120VAC-Dom. or 230VAC-Int'l.
8. With power ON and P1 still connected, insert probes into back of P1 at positions 1 and 2. Voltage should be 24VAC.
9. If proper voltage is present at positions 4 & 5 of P1 and no voltage at positions 1 and 2, replace the transformer.

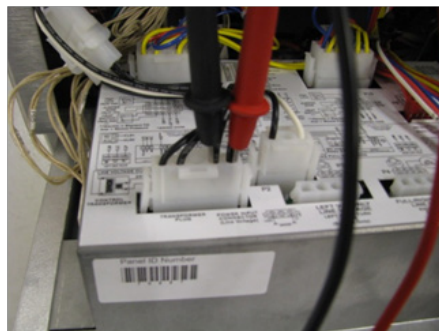

10. If proper voltage is present at positions 1, 2, 4, & 5 of P1 and control panel has no display, unplug each connector from control panel, inspect pins and wire connections, repair as needed, and firmly plug each connector into panel.

7-12. TRANSFORMERS **(Continued)**



AIF Transformer



Control Transformer Connector

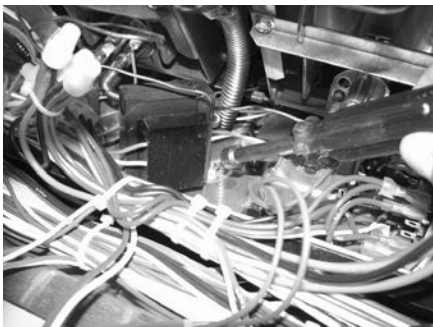

Control Transformer



AIF Transformer

Checkout (Continued)

11. If control panel still does not display, replace panel with a known good control panel. If problem follows control panel, replace panel per paragraph 7-4.

Replacement:



To avoid electrical shock or property damage, move the power switch to OFF and disconnect main circuit breaker, or unplug cord at wall receptacle.

1. Pull-down control panel to access the desired transformer.
2. Label and remove wires from (AIF) transformer, or disconnect white connector on the control transformer.
3. Using a 5/16" socket, remove nuts securing the transformer and pull the transformer from unit.
4. Replace transformer in reverse order.

7-13. FILTER MOTOR RELAY

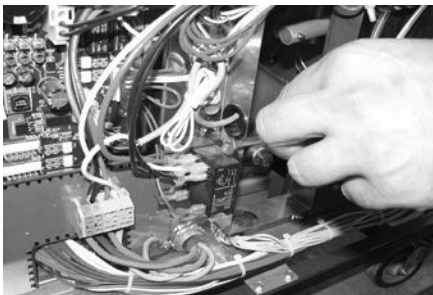
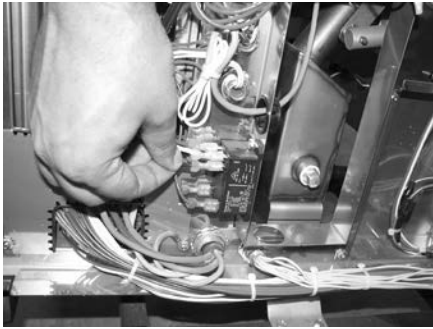

This component is located behind the left control panel and regulates voltage to the filter motor.

Replacement:



To avoid electrical shock or property damage, move the power switch to OFF and disconnect main circuit breaker, or unplug cord at wall receptacle.

1. Remove left side panel.
2. Label and remove wires from relay.
3. Using a 5/16" wrench, remove nuts securing the relay and remove relay from fryer.
4. Install new relay in reverse order.

7-14. GAS CONTROL VALVES



The gas control valve assembly controls flow of gas to the pilot and the main burner. Valve has two 24 volt coils, which are regulated by terminals PV and MV on the valve. For gas flow to the pilot, 24 VAC must be present between the PV and COM terminals. For gas flow to the main burner, 24 VAC must be present between the MV and COM terminals.



TO AVOID INJURY, PROPERTY DAMAGE, OR EXPLOSION, BEFORE REPLACING STARTING THIS PROCEDURE, DO THE FOLLOWING:

- **MOVE THE POWER/PUMP SWITCH TO THE "OFF" POSITION.**
- **DISCONNECT THE MAIN CIRCUIT BREAKER AT THE WALL, OR UNPLUG THE POWER CORD.**
- **TURN OFF THE MAIN GAS SUPPLY TO THE FRYER AND DISCONNECT AND CAP THE SUPPLY LINE TO FRYER.**

7-14. GAS CONTROL VALVES
(Control)



Replacement:

1. Remove the appropriate side panel and/or open the doors.

2. Label and remove wires from gas valve.

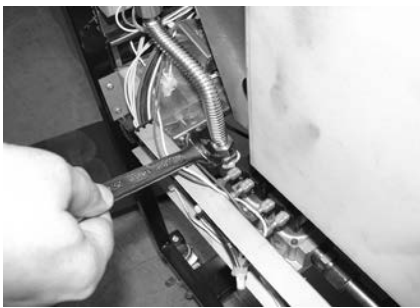

3. Using a 5/8" wrench, loosen the flexible gas line fitting.



4. Using a 1" wrench, loosen the rear fitting and pull assembly from the unit.

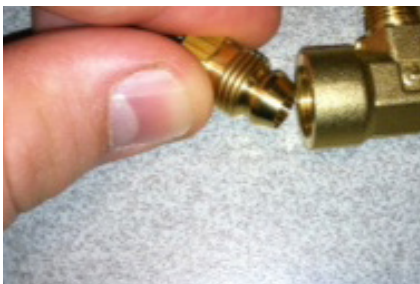

5. Remove the nipple from the brass elbow. With the nipple removed, the fitting will clear the gas valve body.

6. Pull fittings from gas valve and attach the fittings to new gas valve, in the same orientation.

7. Install new gas valve in reverse order.

7-15. BLOWER MOTORS

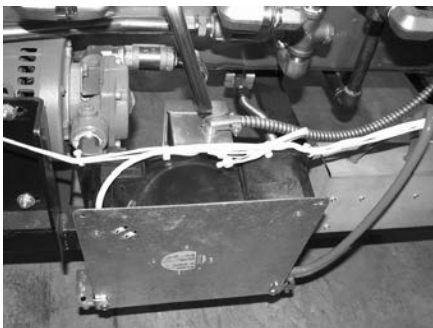
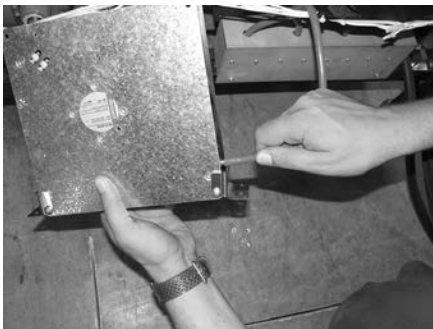
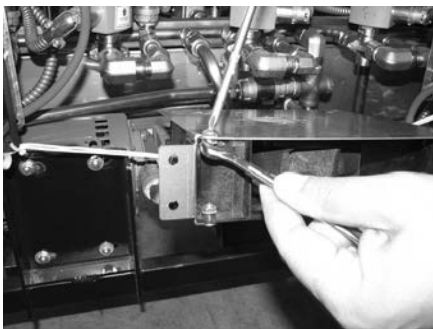
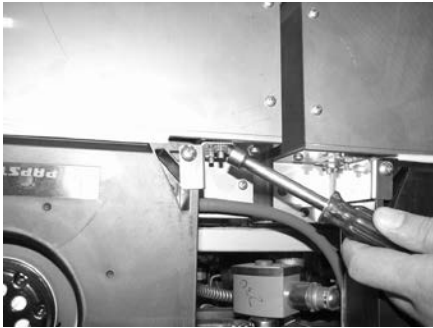

The blower motor assembly creates the draft for the burners. If the blower motor fails, the air switch fails to close, causing an “E-20B” error code in the display.

Replacement:



To avoid electrical shock or property damage, move the power switch to OFF and disconnect main circuit breaker, or unplug cord at wall receptacle.

1. Remove the bottom, rear panel.
2. Using a 3/8” socket or nut driver, remove nuts securing the blower brackets to the fryer.
3. Remove the brackets from the blower.
4. Remove the pressure tube from the blower.
5. Locate and cut wires and remove blower from unit.
6. Connect new blower motor wires to fryer using wire nuts, and install new blower motor in reverse order as above.

NOTICE

Before installing the bottom, rear cover, clean blower intake slots to ensure sufficient air flow to the blowers.



7-16. DRAIN PAN SWITCH

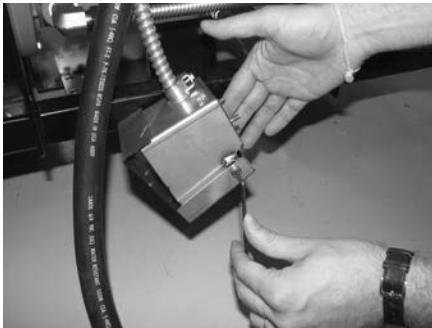
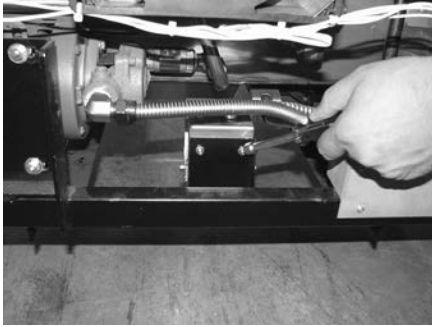

This switch closes when the drain pan is pushed properly in place under the fryer. If the drain pan is not properly in place, or the drain switch is faulty, display prompts such as, “CHECK PAN” or “CHANGE FILTER PAD” shows in the display.

Removal:

1. Drain pan switch is located on the rear of fryer. Using a 3/8” socket or nut driver, remove the nuts securing the drain switch bracket to the fryer.
2. Using a 1/8” Allen wrench, remove shoulder bolt securing the cover and remove cover.
3. Using a Phillips-Head screwdriver, remove screws securing switch to bracket and remove switch from bracket.
4. Label and remove wires from switch

Checkout:

5. Check for continuity across the normally open and the common terminals of drain switch. Circuit should show open and when plunger is pressed, show closed. Replace switch if faulty, placing wires on new switch on normally open and common terminals.

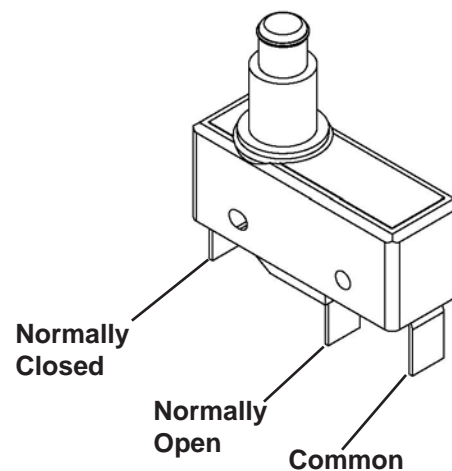

7-17. FILTER AND JIB LIGHTS

Replacement:



To avoid electrical shock or property damage, move the power switch to OFF and disconnect main circuit breaker, or unplug cord at wall receptacle.

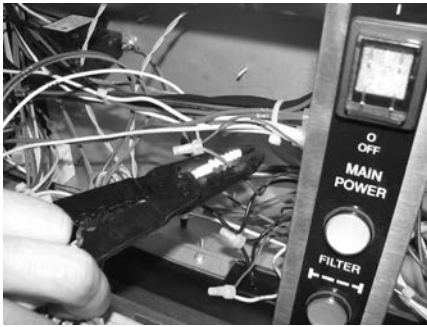

1. Remove control panel.

2. Locate wires to light and cut wires.



3. Using a 13/16", deep-well socket (see photo at left) remove nut on the back side of panel and pull the light from the front of the panel.

4. Install new light with deep-well socket, connect wires with wire nuts and reinstall the control panel.

5. Restore power to the unit.

7-18. AIR PRESSURE SWITCHES

The vacuum switch senses the flow of air coming from the blower. If the airflow is reduced below a set amount, the switch cuts power to the control valve, which shuts the burners down.

Replacement:



To avoid electrical shock or property damage, move the power switch to OFF and disconnect main circuit breaker, or unplug cord at wall receptacle.

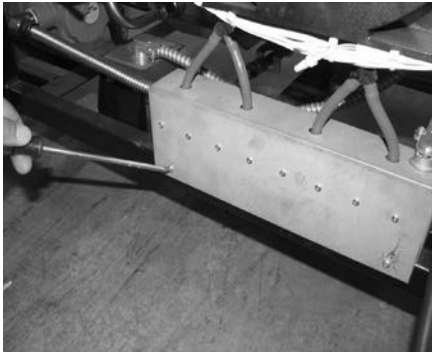

1. Air switches are located on the rear of the fryer. Using Phillip's-Head screwdriver, remove the 2 screws securing the outer cover and remove cover.

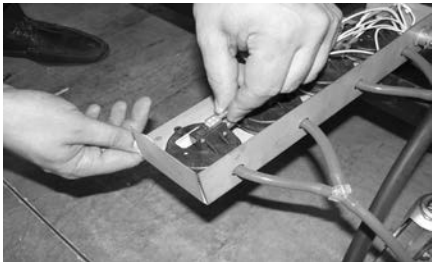

2. Label and pull wires from switch.

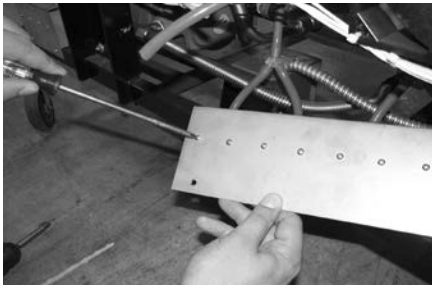

3. Pull tube from switch and using a Phillip's-Head screwdriver, remove 2 screws securing the switch to the bracket and remove switch.

4. Install new switch in reverse order and restore power to unit.

**7-19. IGNITOR & FLAME
SENSOR ASSEMBLY**



The flame sensor should glow a bright red when pilot is lit and allows gas control valve to open. If it does not sense a flame, it shuts off the gas control valve.

Flame Sensor Replacement:

1. Remove control panel.
2. Pull wire from flame sensor.
3. Using a 7/16" wrench, remove nut securing the flame sensor and pull the sensor from the unit.
4. Install new flame sensor in reverse order.

Ignitor Replacement:



TO AVOID INJURY, PROPERTY DAMAGE, OR EXPLOSION, BEFORE STARTING THIS PROCEDURE, DO THE FOLLOWING:

- **MOVE THE POWER/PUMP SWITCH TO THE "OFF" POSITION.**
- **DISCONNECT THE MAIN CIRCUIT BREAKER AT THE WALL, OR UNPLUG THE POWER CORD.**
- **TURN OFF THE MAIN GAS SUPPLY TO THE FRYER AND DISCONNECT AND CAP THE SUPPLY LINE TO FRYER.**

1. Follow steps 1 to 3 above.
2. Using a 7/16" wrench, loosen the pilot, gas line fitting.
3. Using a small Phillip's-Head remove 2 screws securing the ignitor assembly.
4. Pull wire from ignition module and remove ignitor assembly from unit.
5. Install new ignitor assembly in reverse order.

7-20. IGNITION MODULES

During normal operation, the ignition modules send 24 volts to the ignitors and gas control valve. If a module does not sense a pilot flame, the module starts the ignition process again. But, if a pilot light goes out for longer than 15 seconds, or it goes out 3 times within 15 seconds, the module keeps the 24 volts from reaching the gas control valve. The burners shut down.

Replacement:



To avoid electrical shock or property damage, move the power switch to OFF and disconnect main circuit breaker, or unplug cord at wall receptacle.

1. Open the left door and using a Phillip's-Head screwdriver, remove the screws securing the module cover and remove cover.

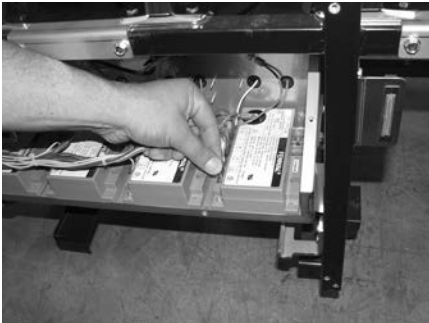

2. Label and pull the wires from the module.

3. Using a 3/8" socket or nut driver remove the nuts securing the module and remove module from unit.

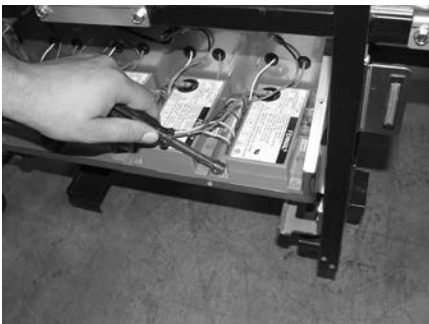

4. Install new module in reverse order and restore power to the unit.

**7-21. PRESSURE
TRANSDUCER**

This component controls the AIF filter pump by sensing the pressure in the expansion chamber.

Voltage range is 0.5 to 4.5 VDC, corresponding to a pressure range of 0 to 30 PSIG

A measured pressure below -1.5 PSI or above 32 PSI may indicate a failed transducer, it has become disconnected, or a clogged expansion chamber.

NOTICE

To view the the pressure, press ◀ and ▶ at the same time and “*HP* *INFO*” shows in the display, followed by “1. E-LOG”. Press ▶ until “14. AIF” shows in the display. Press ▼ until “PRESSURE SENSOR” shows in the left display. Press X button to show pressure in PSI.

An over-pressure issue can also indicate a return valve failing to open, instead of a faulty transducer or a clogged chamber.

In case of a clogged expansion chamber, remove the clean-out plugs at each end of the chamber to clean the obstructions inside the chamber. Photo at left.

Extra long fill times or oil bubbling at end of an AIF cycle may be signs of a clogged expansion chamber or faulty transducer.

Replacement:



To avoid electrical shock or property damage, move the power switch to OFF and disconnect main circuit breaker, or unplug cord at wall receptacle.

1. Remove the left side panel.
2. Pull-out on the clip, while pushing up on the wire harness connector, at the top of the transducer, to remove wires.
3. Using a 1-1/16” wrench, remove the transducer from the expansion chamber.
4. Using pipe thread sealant, install new transducer in reverse order and restore power to the unit.

Expansion Chamber

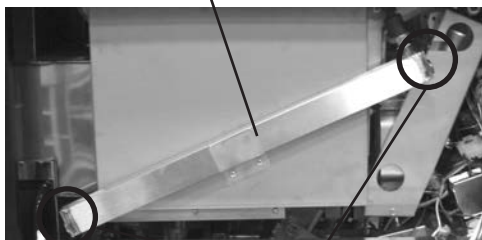

Clean-out Plugs



SECTION 8. PARTS INFORMATION

8-1. INTRODUCTION

This section lists the replaceable parts of the Henny Penny Model LVG fryer.

8-2. GENUINE PARTS

Use only genuine Henny Penny parts in your fryer. Using a part of lesser quality or substitute design may result in damage to the unit or personal injury.

8-3. WHEN ORDERING PARTS

Once the parts that you want to order have been found in the parts list, write down the following information:

Item Number	<u>2</u>	Example:
Part Number	60241	
Description	High Limit	

From the data plate, list the following information:

Product Number	<u>01100</u>	Example:
Serial Number	0001	
Voltage	208	

8-4. PRICES

Your distributor has a price parts list and will be glad to inform you of the cost of your parts order.

8-5. DELIVERY

Commonly replaced items are stocked by your distributor and will be sent out when your order is received. Other parts will be ordered, by your distributor, from Henny Penny Corp. Normally, these will be sent to your distributor within three working days.

8-6. WARRANTY

All replacement parts (except lamps and fuses) are warranted for 90 days against manufacturing defects and workmanship. If damage occurs during shipping, notify the carrier at once so that a claim may be properly filed. Refer to warranty in the front of this manual for other rights and limitations.

8-7. RECOMMENDED SPARE PARTS FOR DISTRIBUTORS

Recommended replacement parts, stocked by your distributor, are indicated with √ in the parts lists. Please use care when ordering recommended parts, because all voltages and variations are marked. Distributors should order parts based upon common voltages and equipment sold in their territory.

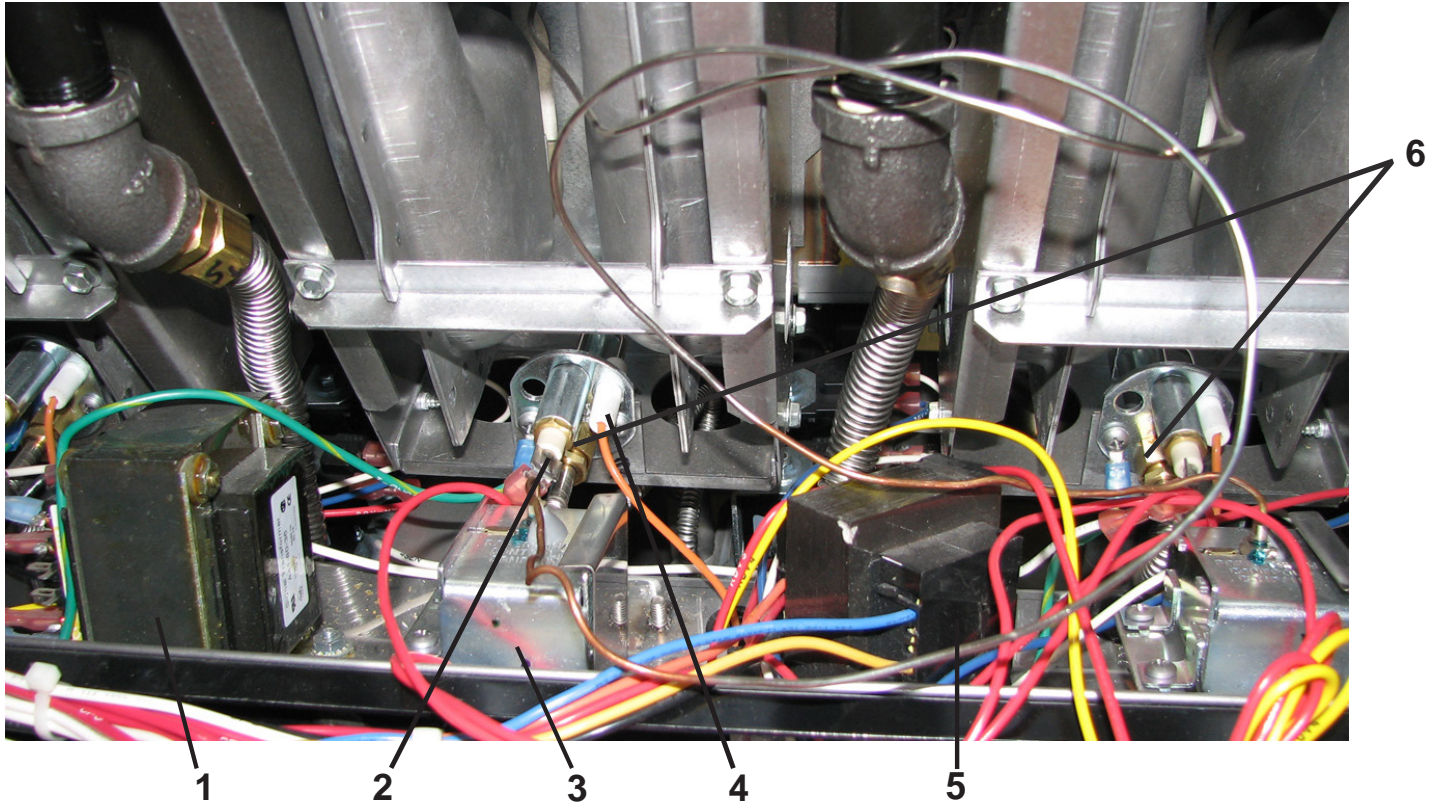

Item No.	Part No.	Description	Quantity
√ 1	TS22-012	TRANSFORMER - AIF	1
√ 2	76978	FLAME SENSOR.....	2/vat
√ 3	16738	HIGH LIMIT - 450°F.....	1/vat
√ 4	75854	ASSY - SPARK IGNITOR (PILOT)	2/vat
√ 5	84391	ASSY-75VA TRANSFORMER (120V-Pri/24v-Sec)	1/vat
√ 5	84134	ASSY-75VA TRANSFORMER (208V-Pri/24v-Sec)	1/vat
√ 5	84135	ASSY-75VA TRANSFORMER (240V-Pri/24v-Sec)	1/vat
6	76979	PILOT ORFACE (see chart on next page).....	A/R
7*	76921	BURNER - ORIFICE - BRASS (See chart on next page).....	4/vat
8*	140086	KIT-CONVERSION (NAT TO LP) Split Vat	1/well
9*	140087	KIT-CONVERSION (NAT TO LP) Full Vat	1/well
10*	140088	KIT-CONVERSION (LP TO NAT) Split Vat	1/well
11*	140089	KIT-CONVERSION (LP TO NAT) Full Vat	1/well

√ recommended parts / A/R- As required

Burner Orifice			
PART NO.	ORIFICE DRILL SIZE (DIA.)	GAS TYPE	ALTITUDE
76921-001	#45 (0.082)	NATURAL	<5301
76921-001	#45 (0.082)	12H, 12E	--
76921-002	1.30mm (0.0512)	PROPANE	ALL
76921-002	1.30mm (0.0512)	13P	ALL
76921-003	#44 (0.086)	NATURAL	5302 - 7701
76921-004	#43 (0.089)	NATURAL	7702 - 10101
76921-005	#42 (0.0935)	12S	--
76921-006	#51 (0.067)	12E+	--
76921-007	2.30mm (0.0906)	12L	--
76921-008	1.25mm (0.0492)	13B/P	--

Pilot Orifice	
PART NO.	GAS TYPE
76979-001	NATURAL
76921-001	12H, 12E

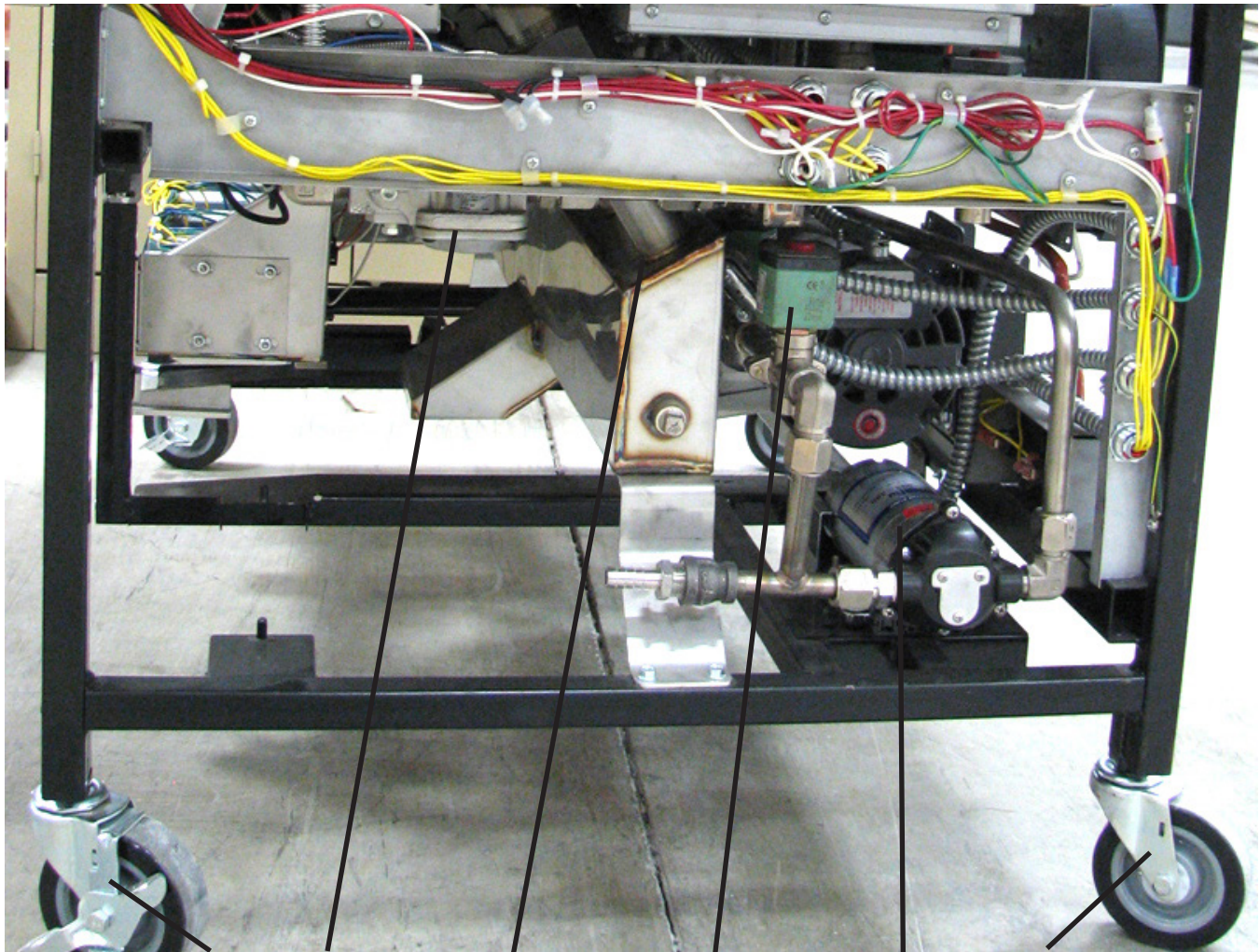

Item No.	Part No.	Description	Quantity
1	77575	CASTER - 4" - W/BRAKE	2
√ 2	78118	VALVE - GAS CONTROL - NAT.....	1/vat
√ 2	78517	VALVE - GAS CONTROL - LP.....	1/vat
√ 3	76948	O-RING.....	1/vat
√ 4	73647	SOLENOID - ASCO - 120V (JIB Solenoids).....	2
√ 4	74582	SOLENOID - ASCO - 230V (JIB Solenoids).....	2
	140229	---KIT-SOLENOID REPAIR	A/R
√ 5	73473	PUMP - OIL TOP OFF - 120V	1
√ 5	74583	PUMP - OIL TOP OFF - 230V	1
6	77679	CASTER - 4"	2

√ recommended parts

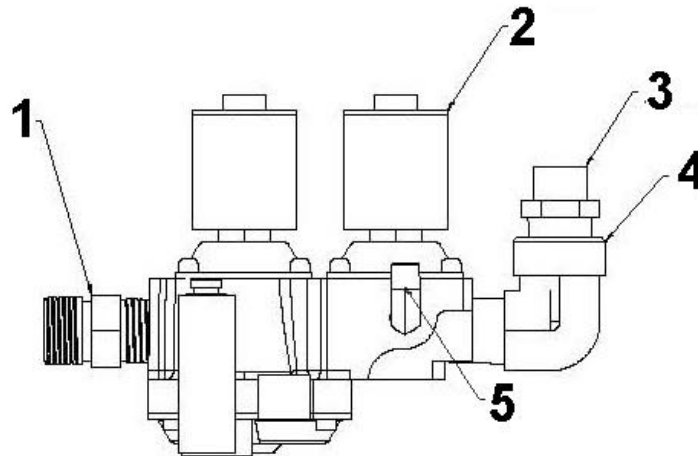

NON-CE GAS VALVE ASSEMBLY

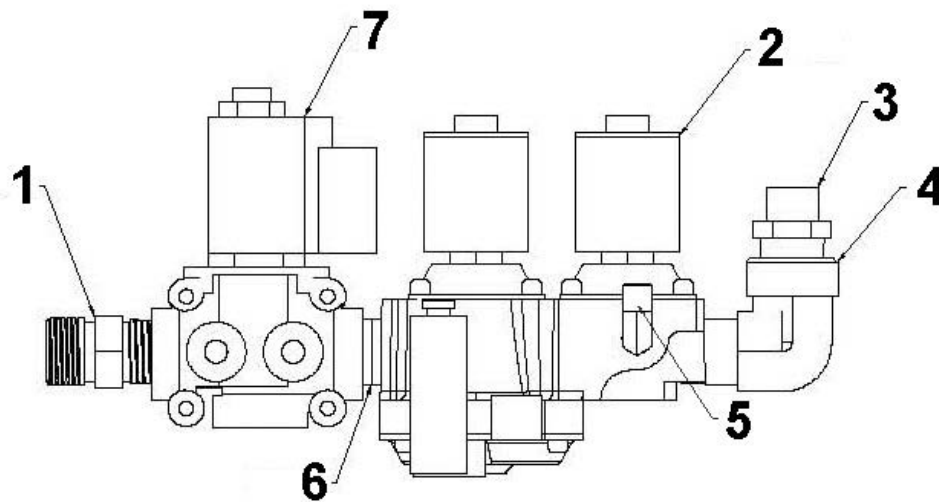

CE GAS VALVE ASSEMBLY

Item No.	Part No.	Description	Quantity (per assy)
1	16807	FITTING - MALE CONNECTOR.....	1
√ 2	78118	VALVE - GAS CONTROL - NAT.....	1
2	87837	VALVE-GAS 24V NAT SPLIT	1
√ 2	78517	VALVE - GAS CONTROL - LP.....	1
3	FP01-211	CONNECTOR - MALE 1/2 TUBE TO 1/2 NPT	1
4	16239	ELBOW - STREET - 90 DEGREES	1
5	FP05-004	ELBOW - 1/4 TUBE TO 1/8 PIPE Z.....	2
6	FP01-028	NIPPLE - CLOSE 1/2 NPT SS 1 LG.....	1
√ 7	34802	VALVE - SOLENOID GAS - 24V - 50/60 HZ.....	2

√ recommended parts

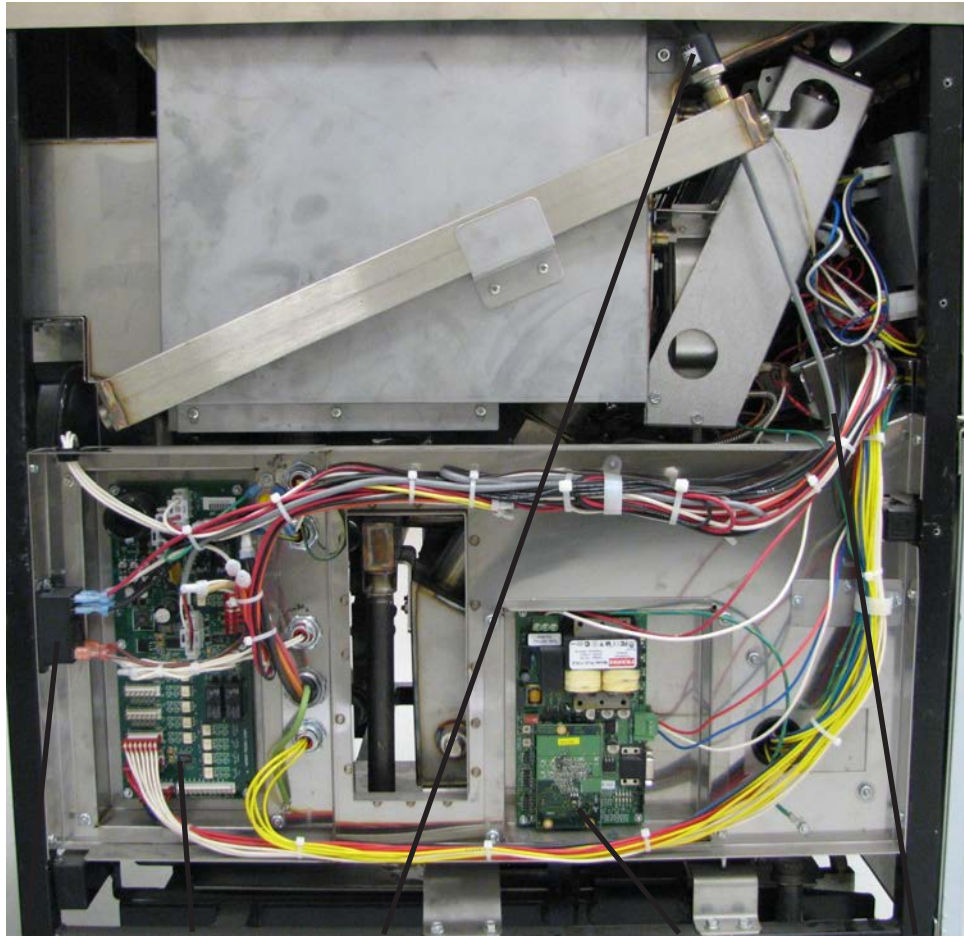

Item No.	Part No.	Description	Quantity
√ 1	ME90-008	RELAY - PUMP MOTOR - 12 VDC - 30 AMP	1
√ 2	76463	PC BOARD - AIF	1
√ 3	79213	TRANSDUCER - PRESSUER 30 PSI	1
4	79596-XXXX	GATEWAY PC BOARD (See chart below).....	1
5	84384-001	HARNESS - PRESSURE TRANSDUCER	1
6*	51065	ASSY-EMC FILTER BOARD.....	1
6*	82914	ASSY-EMC FILTER BOARD - CE	1
7*	80373	BLOCK -TERMINAL POWER - CE.....	1

Part No.	Voltage	Coupling	Transceiver Type	Model
79596-1102	115	LE	NON-CENELEC	LVG-102
79596-1103	115	LE	NON-CENELEC	LVG-103
79596-1104	115	LE	NON-CENELEC	LVG-104
79596-1202	115	LN	NON-CENELEC	LVG-102
79596-1203	115	LN	NON-CENELEC	LVG-103
79596-1204	115	LN	NON-CENELEC	LVG-104
79596-2202	230	LN	NON-CENELEC	LVG-102
79596-2203	230	LN	NON-CENELEC	LVG-103
79596-2204	230	LN	NON-CENELEC	LVG-104
79596-2212	230	LN	CENELEC	LVG-102
79596-2213	230	LN	CENELEC	LVG-103
79596-2214	230	LN	CENELEC	LVG-104

√ recommended parts / * not shown

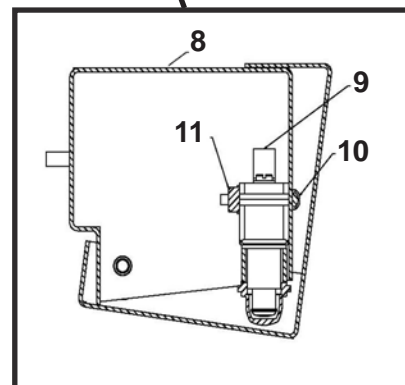
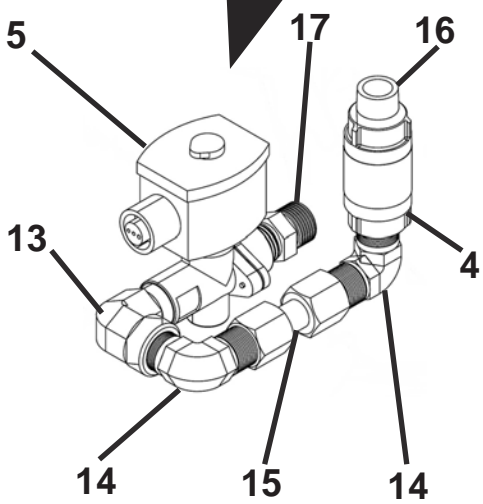
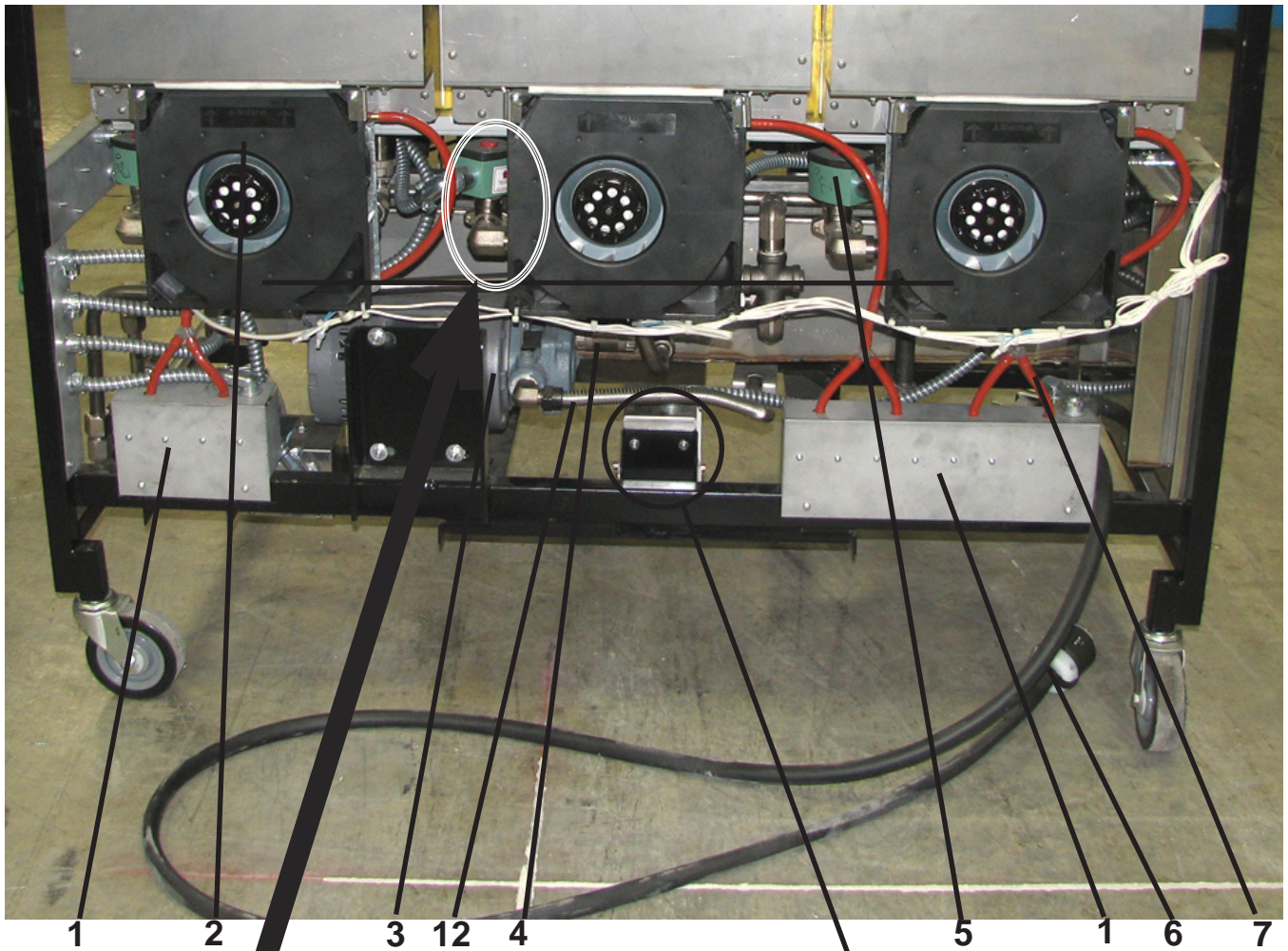

Item No.	Part No.	Description	Quantity
√ 1	77992	SWITCH - PRESSURE - 0.80 (behind covers).....	1/vat
√ 2	77826-001	MOTOR - BLOWER - 230V.....	1/ control board
√ 2	77826-002	MOTOR - BLOWER - 120V.....	1/ control board
3	67589	PUMP & MOTOR ASSY...(See page 8-19 for details).....	1
√	67583	MOTOR - 1/2 HORSE.....	1
	17437	PUMP - FILTER	1
	17476	SEAL KIT	1
√ 4	74469	VALVE-CHECK-1/2" (Vat Fill) (Use item 20 on threads)	1/vat
√ 5	73647	SOLENOID - ASCO - 120V (return valves).....	1/vat
√ 5	74582	SOLENOID - ASCO - 230V (return valves).....	1/vat
6	73517	ASSY - POWER CORD 120V	1
7	79443-X	TUBE - PRESSURE SWITCH (see chart below).....	AR
8	80153	ASSY - SWITCH HSG W/BOOT.....	1
9	80148	ASSY-DRAIN SWITCH W/BOOT.....	1
10	SC01-058	COVER - SWITCH HOUSING W/BOOT.....	2
11	NS02-005	SCREW - #6-32 X 1 PH PHD C	2
√ 12	77523-002	TUBE-SUCTION-18"	1
13	16239	STREET ELL 90° 1/2"	1/vat
14	17407	CONNECTOR-ELBOW-MALE-1/2"	2/vat
15	75426	ASSY-TEE TO JIB PUMP INLET	1/va
16	FP01-028	NIPPLE-CLOSE-1/2"	1/vat
17	16807	FITTING-CONNECTOR-MALE-1/2" NPT x 5/8" TUBE ...	1/vat
√ 18*	MS01-572	PRIMER-LOCTITE-0.8oz. CAN (check valve threads)	1
19*	82139	BAR-REAR SPACER-LVG-102.....	1
20*	80219	BAR-REAR SPACER-LVG-103.....	1
21*	83792	BAR-REAR SPACER-LVG-104.....	1
22*	FP01-213	FITTING-1/4 WYE HOSE BARB.....	AR

<u>PART NO.</u>	<u>LENGTH</u>
79443-1	2.5"
79443-2	13"
79443-3	19"
79443-4	16"
79443-5	26"
79443-6	14"
79443-7	17"
79443-8	22"
79443-9	32"
79443-10	38"

√ recommended parts
 * not shown
 AR as required

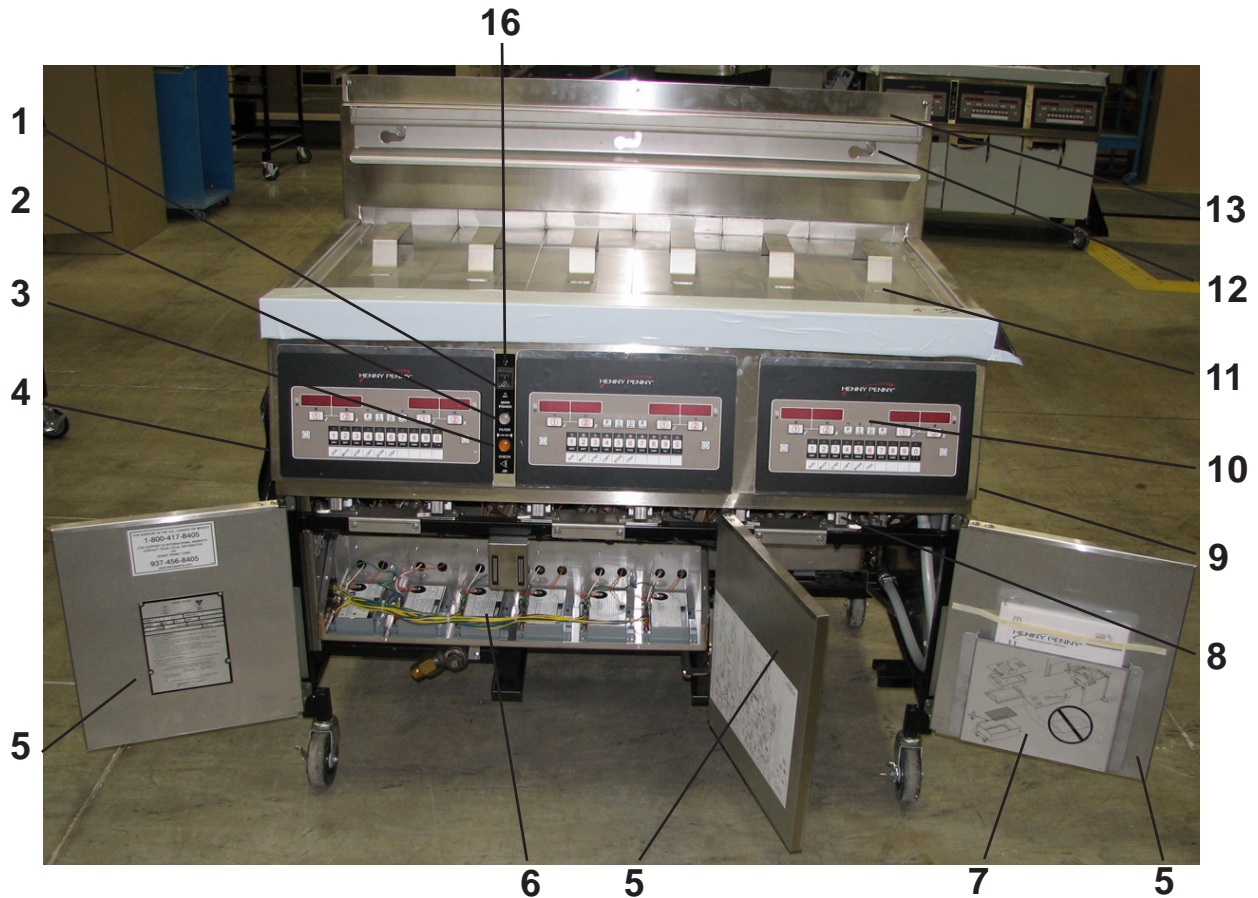

Item No.	Part No.	Description	Quantity
√ 1	52224	SWITCH - POWER.....	1
√ 2	75860	LIGHT - INDICATOR - BLUE.....	1
√ 3	75859	LIGHT - INDICATOR - YELLOW.....	1
4	76930	PANEL-LH SIDE-LVG10X	1
5	-----	ASSY-DOOR.....	See chart on next page
√ 6	77839	MODULES - IGNITION.....	1/vat
√ 6	77602	MODULES- CE- IGNITION	1/vat
7	78482	HOLDER-CHART.....	1
√ 8	78356	ASSY-DRAIN ACTUATOR.....	1/vat
9	76931	PANEL-RH SIDE-LVG10X	1
√ 10	SEE 8-14	ASSY - CONTROL - LOV	AR
11	03647	COVER - SPLIT VAT.....	1/vat
11	03646	COVER - FULL VAT.....	1/vat
12	77842	HANGER-BASKET - LVG-102	1
12	77709	HANGER-BASKET - LVG-103	1
12	77934	HANGER-BASKET - LVG-104	1
13	82002	DEFLECTOR-REAR COVER FLUE-LVG-102 (Before SN: BU1006014)	1
13	81954	DEFLECTOR-REAR COVER FLUE-LVG-103 (Before SN: BU1009013)	1
13	83357	DEFLECTOR-REAR COVER FLUE-LVG-104 (Before SN: BU1005051)	1
√ 14*	60818	RELAY - 24VAC COIL (Full Vat Fryers Only).....	1/vat
15*	140071	TETHER KIT-GAS FRYER.....	1
16	77103	DECAL-FLTR/CK JIB/MAIN POWER	1

√ recommended parts / * not shown / AR as required

79314 LH Door Assy with Label	74302 RH Door Assy with Holder
--	---

Model LVG-102

79314 LH Door Assy with Label	87041 RH Door Assy without Holder	74302 RH Door Assy with Holder
--	--	---

Model LVG-103

89897 LH Door Assy with Label	74301 LH Door Assy without Holder	87041 RH Door Assy without Holder	74302 RH Door Assy with Holder
--	--	--	---

Model LVG-104

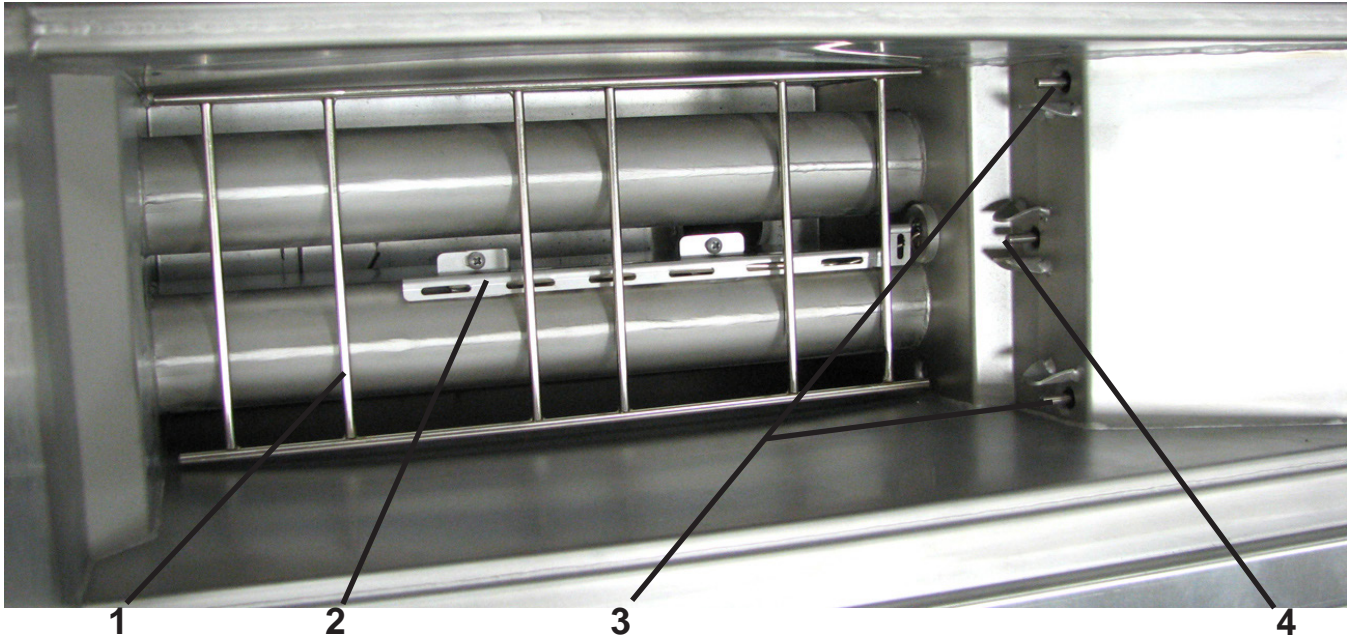

Item No.	Part No.	Description	Quantity
√ 1	76980	RACK - SPLIT VAT	1/vat
√ 1	76982	RACK - FULL VAT	1/vat
2	77061	GUARD - HIGH LIMIT - LVG.....	1/vat
√ 3	14974	PROBE - LEVEL SENSE - 2.5 in.	2/vat
√ 4	14974	PROBE - TEMPERATURE - 2.5 in.	1/vat

√ recommended parts

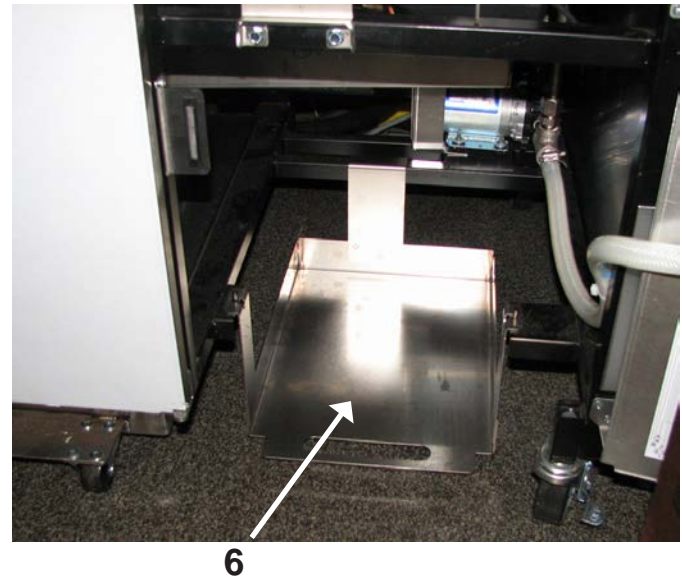
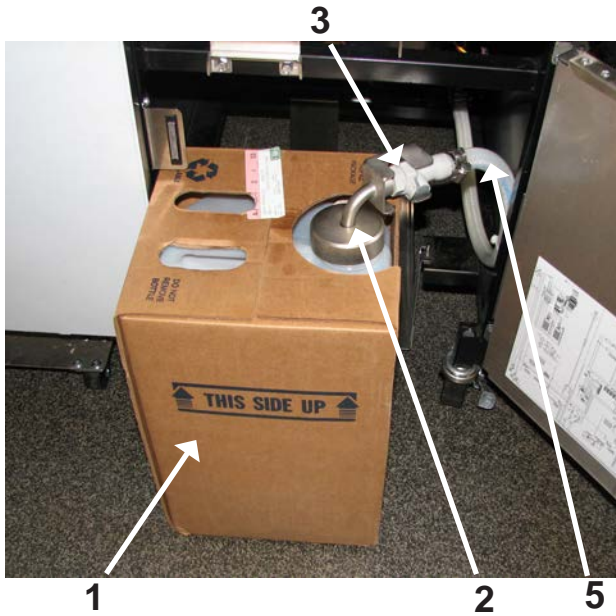

Item No.	Part No.	Description	Quantity
1	03617	ACCESSORY-JUG-AUTO TOP OFF (EMPTY).....	1
2	78992	ASSY-JIB TUBE & QUICK DISC (includes items 3 & 4).....	1
2	80490	ASSY-INT'L. JIB TUBE & QUICK DISC (includes items 3 & 4)	1
3	FP05-017	QUICK DISCONNECT - 3/8"	1
√ 4*	MS01-561	O-RING - JIB TUBE	1
√ 5	77288	ASSY - HOSE.....	1
6	77630	WELD ASSY - JIB SHELF	1

√ recommended parts

* not shown

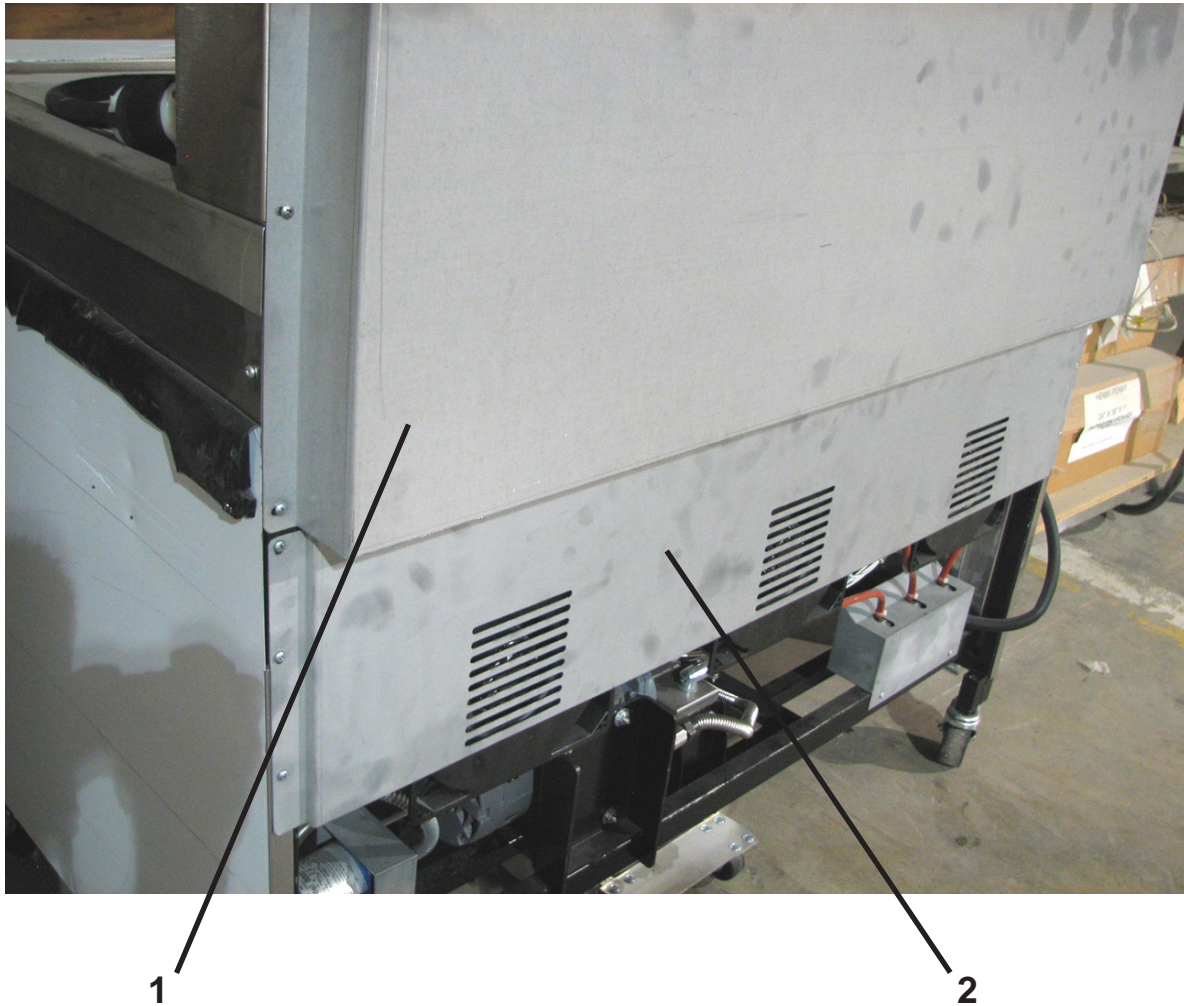

Item No.	Part No.	Description	Quantity
1	83784	COVER - REAR SHROUD - LVG-102 (Before SN: BU1006014) ..	1
1	86415	COVER - REAR SHROUD - LVG-102 (SN: BU1006014 & after)..	1
1	81223	COVER - REAR SHROUD - LVG-103 (Before SN: BU1009013) ..	1
1	86416	COVER - REAR SHROUD - LVG-103 (SN: BU1009013 & after)..	1
1	79565	COVER - REAR SHROUD - LVG-104 (Before SN: BU1005051) ..	1
1	86417	COVER - REAR SHROUD - LVG-104 (SN: BU1005051 & after)..	1
2	78306	COVER - REAR - LOWER - LVG-102.....	1
2	77665	COVER - REAR - LOWER - LVG-103.....	1
2	80197	COVER - REAR - LOWER - LVG-104.....	1

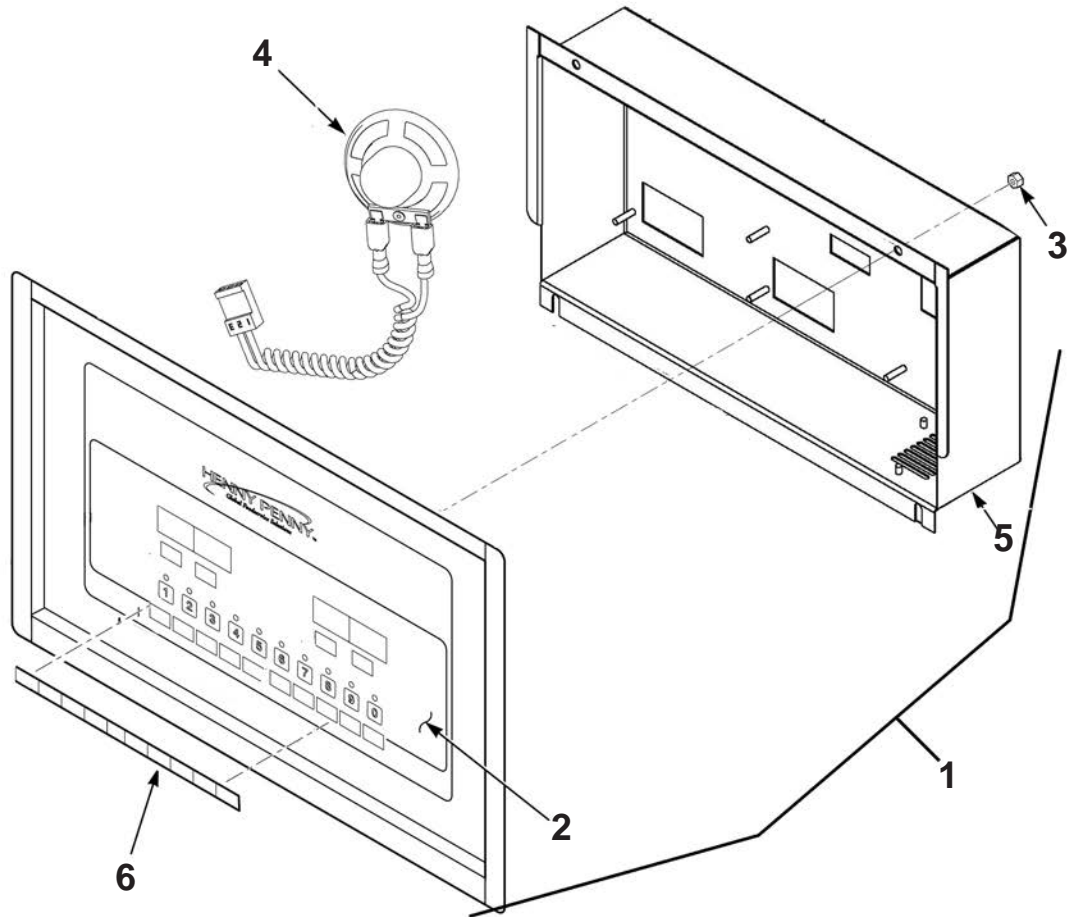

Item No.	Part No.	Description	Quantity
√ 1	96972	ASSY - CONTROL - LOV	3
√ 2	75660	DECAL - LOV MCD	1/control
3	NS02-005	NUT - HEX KEPS #6-32 C	23/control
√ 4	26974	ASSY - SPEAKER	1/control
5	76115	STUD ASSY - CONTROL PANEL COVER	1/control
6	77249	MENU CARD - BLANK - LOV	1/control
6	77250	MENU CARD - FVA - LOV	1/control
6	77251	MENU CARD - SPA - LOV	1/control
7*	MS01-571	TOOL - TERMINAL EXTRACTOR (not shown)	1

√ recommended parts

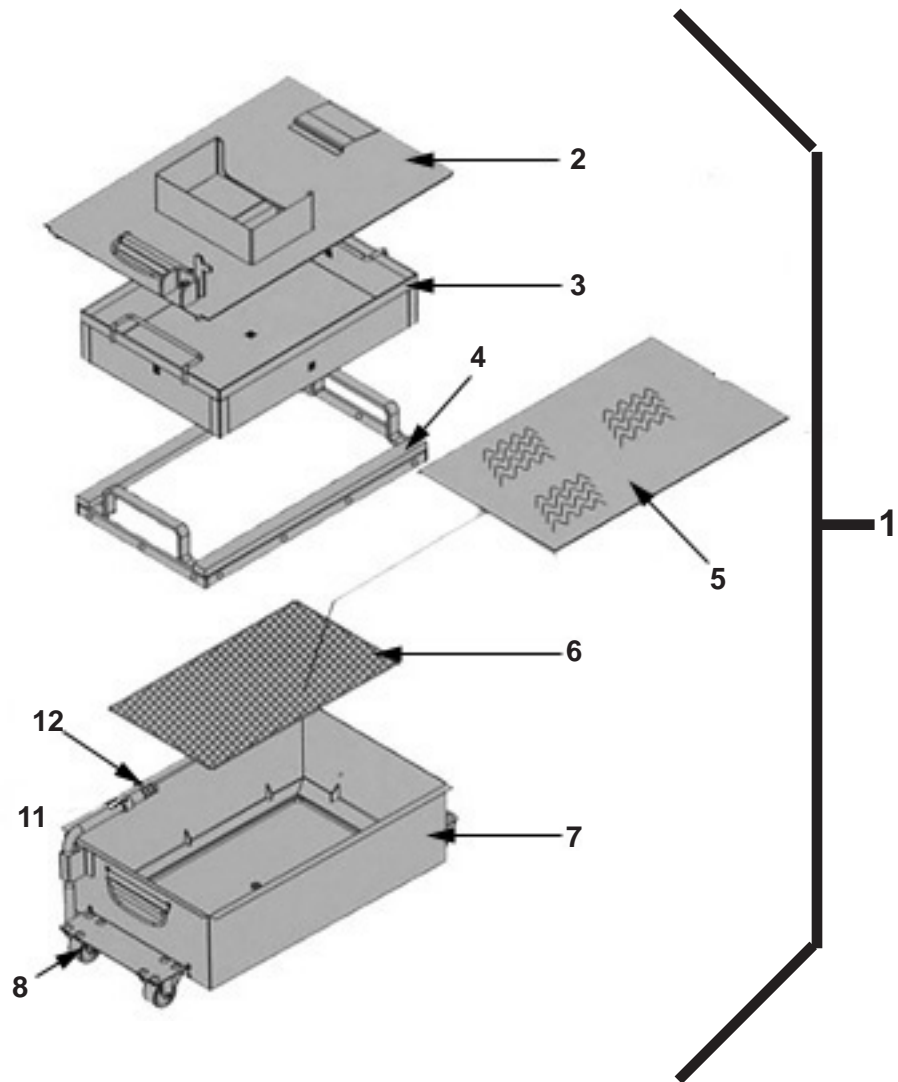

Item No.	Part No.	Description	Quantity
1	78456	ASSY - DRAIN PAN - LVG.....	1
2	82674	ASSY-DRAIN PAN COVER.....	1
3	76259	WELD ASSY-CRUMB CATCHER	1
4	76179	WELD ASSY-FILTER WEIGHT	1
5	03190-054	McD's FILTER KIT (not supplied by Henny Penny).....	1
		(includes fryer cleaner, 30 filter pads, & green cleaner pads)	
6	76375	FILTER-SECTION	1
7	82672	WELD ASSY-DRAIN PAN (Less Cover)	1
8	52487	CASTER - DRAIN PAN.....	4
9*	SC01-009	SCREW (1/4-20 x 1/2).....	16
10*	NS02-002	NUT, KEPS (1/4-20).....	16
11	74573	ADAPTOR - PUMP TO PICKUP TUBE.....	1
√ 12	74189	O-RING-PICKUP TUBE.....	3
√ 13	12126	BRUSH - BLACK L.....	1
√ 14	12112	BRUSH - STRAIGHT WHITE	1
√ 15	12116	BRUSH - FRYER - LONG HANDLE	1

√ recommended parts * not shown

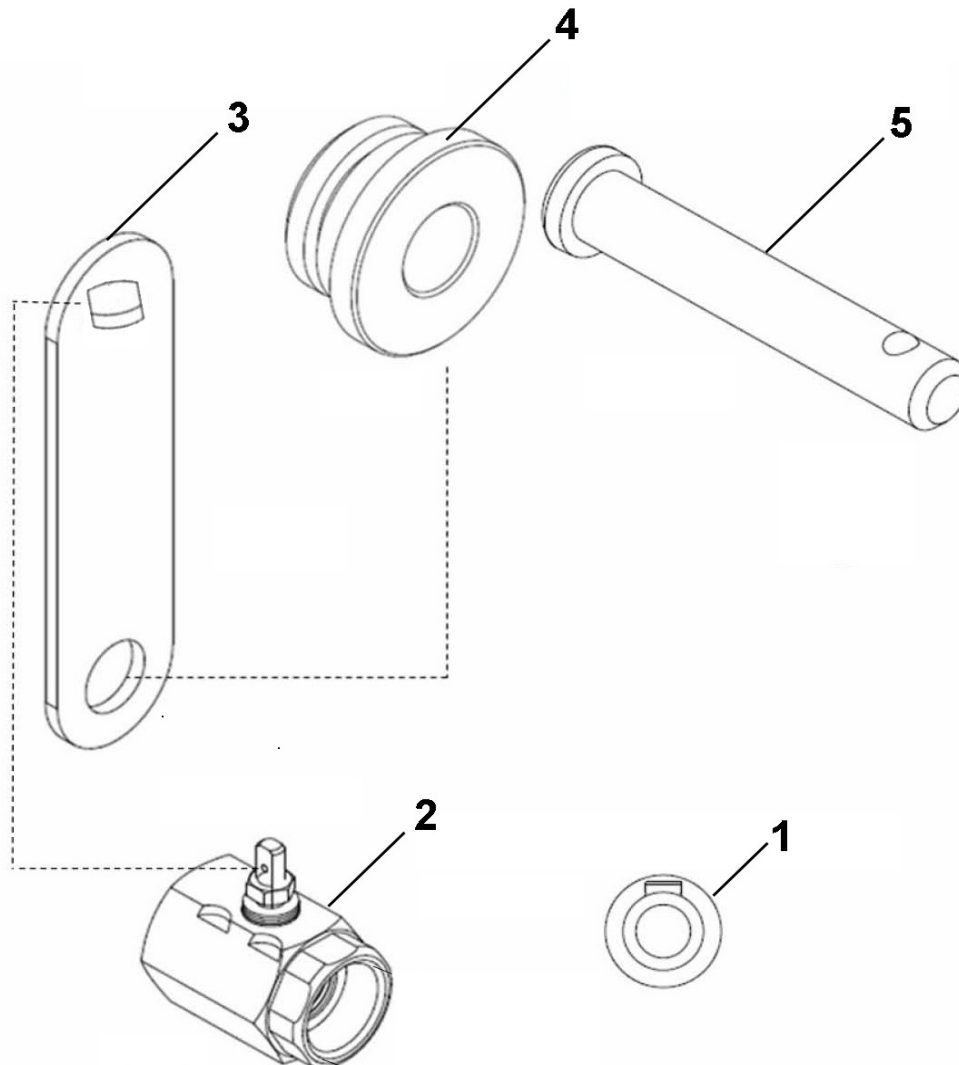

Drain Valve Linkage Parts

Item No.	Part No.	Description	Quantity
1	PN01-031	PIN - LOCKING WEDGE - 1/4 x 1-1/4.....	1/vat
2	76095	VALVE - DRAIN	1/vat
√ 3	76264	HANDLE - PIVOT - DRAIN	1/vat
4	78591	PIVOT - BUSHING - ACTUATOR	1/vat
√ 5	50776	PIN - ACTUATOR - CLEVIS	1/vat
√ 6*	76948	O-RING.....	1/vat
7*	140137	KIT-PIVOT & SPRING HDL LVG100.....	A/R

√ recommended parts / * not shown/ A/R- As Required

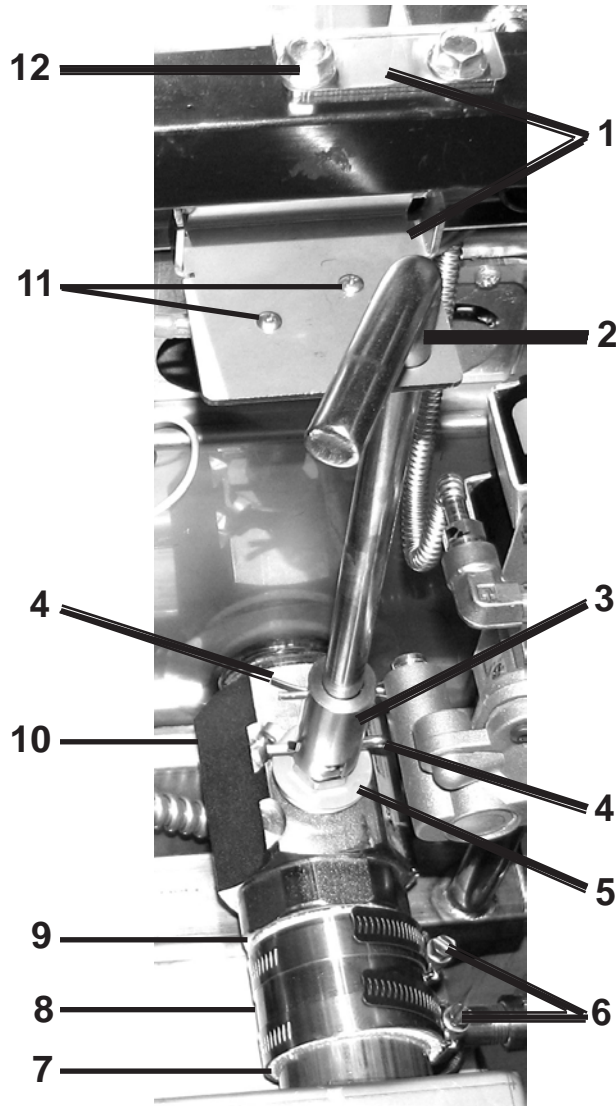

Drain Valve Parts - Fish Vat

Item No.	Part No.	Description	Quantity
1	86122	BRACKET-DR ROD & LEVER SWITCH	1/vat
2	83598	ROD- DRAIN VALVE	1/vat
3	55142	COUPLING-DRAIN VALVE.....	1/vat
√ 4	17255	PIN -COTTER	2/vat
5	74626	STOP-PIVOT DRAIN HANDLE.....	1/vat
6	MS01-307	CLAMP-HOSE.....	2/vat
7	72554	HOSE-MANDREL WRAPPED SILICONE.....	1/vat
8	76598	GUARD-SILICONE HOSE	1/vat
9	74553	EXTENSION-DRAIN	1/vat
10	79590	VALVE-DRAIN.....	1/vat
11	SC01-178	SCREW-4-40 x 3/4"	2/vat
12	SC03-010	SCREW-1/4-20 x 3/4"	2/vat
13*	83096	SWITCH-LEVER.....	1/vat
14*	NS02-009	NUT-4-40	2/vat

√ recommended parts

* not shown

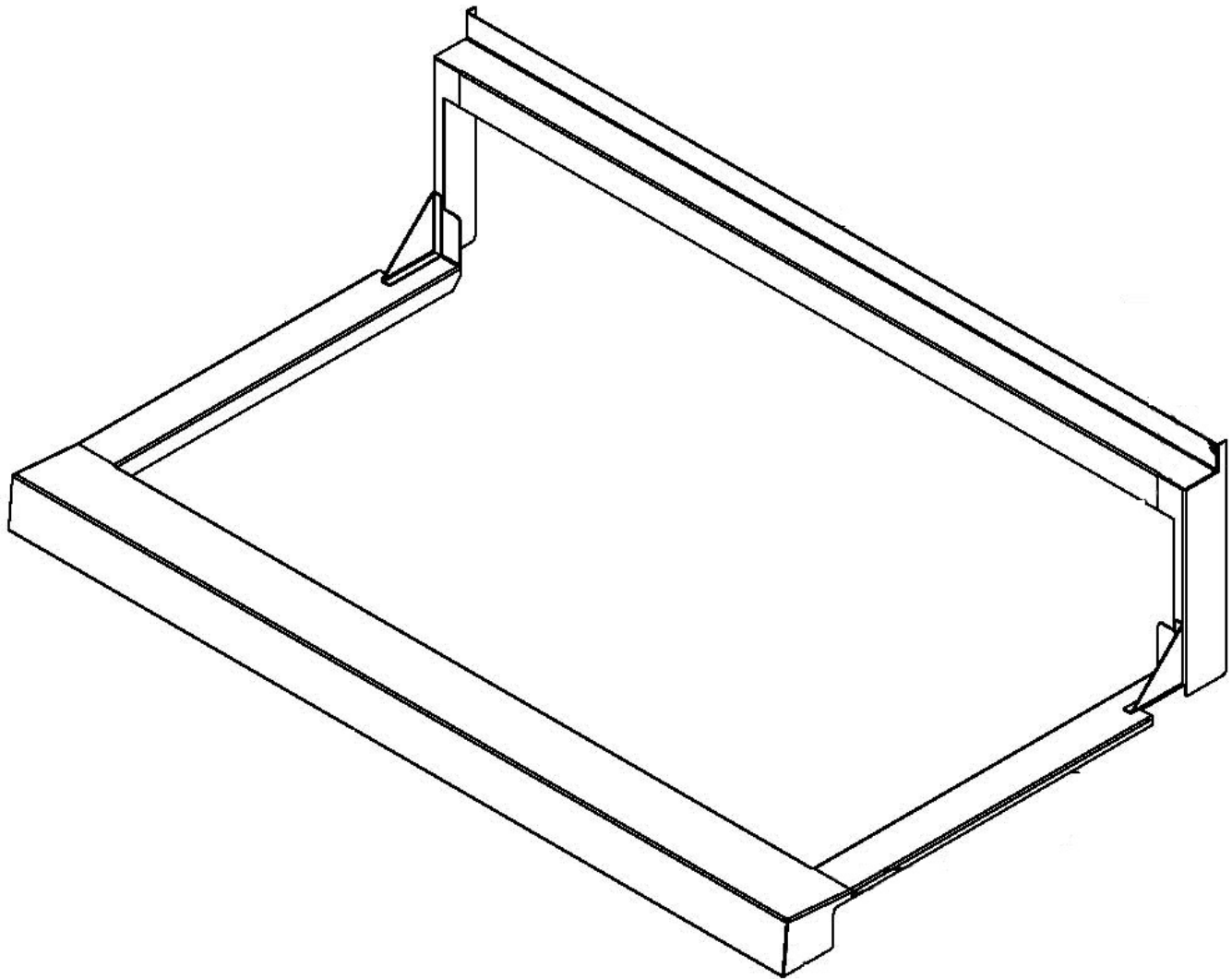

Fry Cap

Item No.	Part No.	Description	Quantity
1	03641	ACCESSORY-FRY CAP - LVG-102.....	1
1	03642	ACCESSORY-FRY CAP - LVG-103.....	1
1	03643	ACCESSORY-FRY CAP - LVG-104.....	1

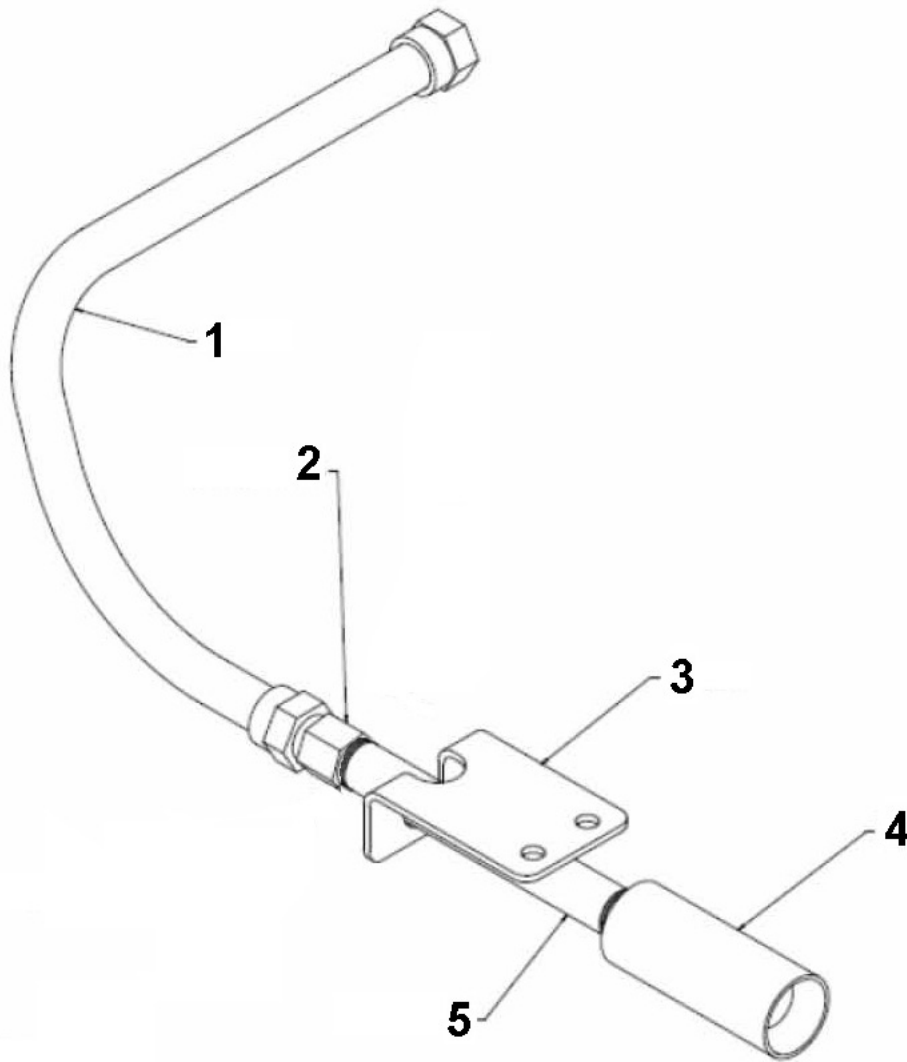

Item No.	Part No.	Description	Quantity
	78814-001	ASSY - SUCTION LINE.....	1
1	77523-002	TUBE-SUCTION 18 IN L DORMONT.....	1
2	FP01-206	CONNECTOR-3/8 NPT FEM 45 FLARE	1
3	77259	BRACKET-PLUG AND PLAY	1
4	77248	ADAPTER-TUBE END	1
5	FP01-204	NIPPLE-3/8 NPT X 6IN L BLACK.....	1

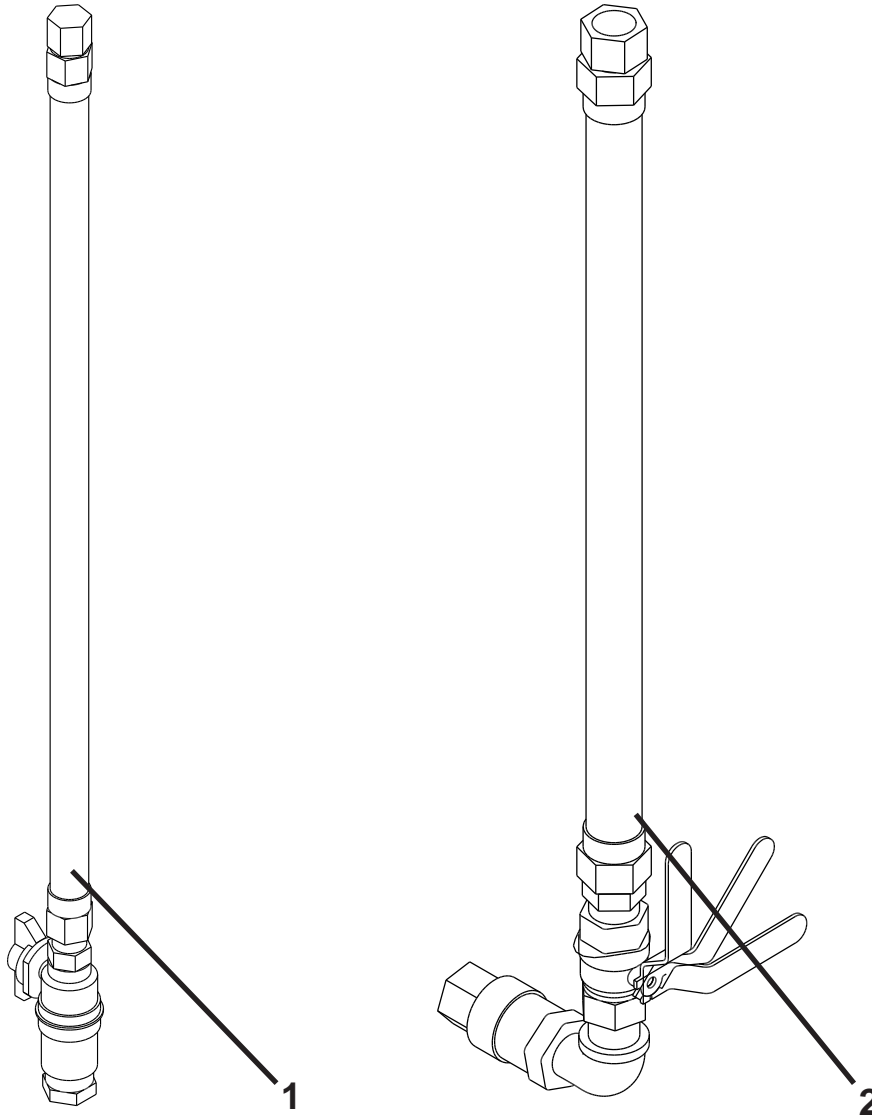

Item No.	Part No.	Description	Quantity
1	79327	FLEXIBLE GAS LINE W/SHUT-OFF VALVE - 2 -WELL-36 IN	1
2	77668-002	FLEXIBLE GAS LINE W/SHUT-OFF VALVE - 3 -WELL-72 IN	1

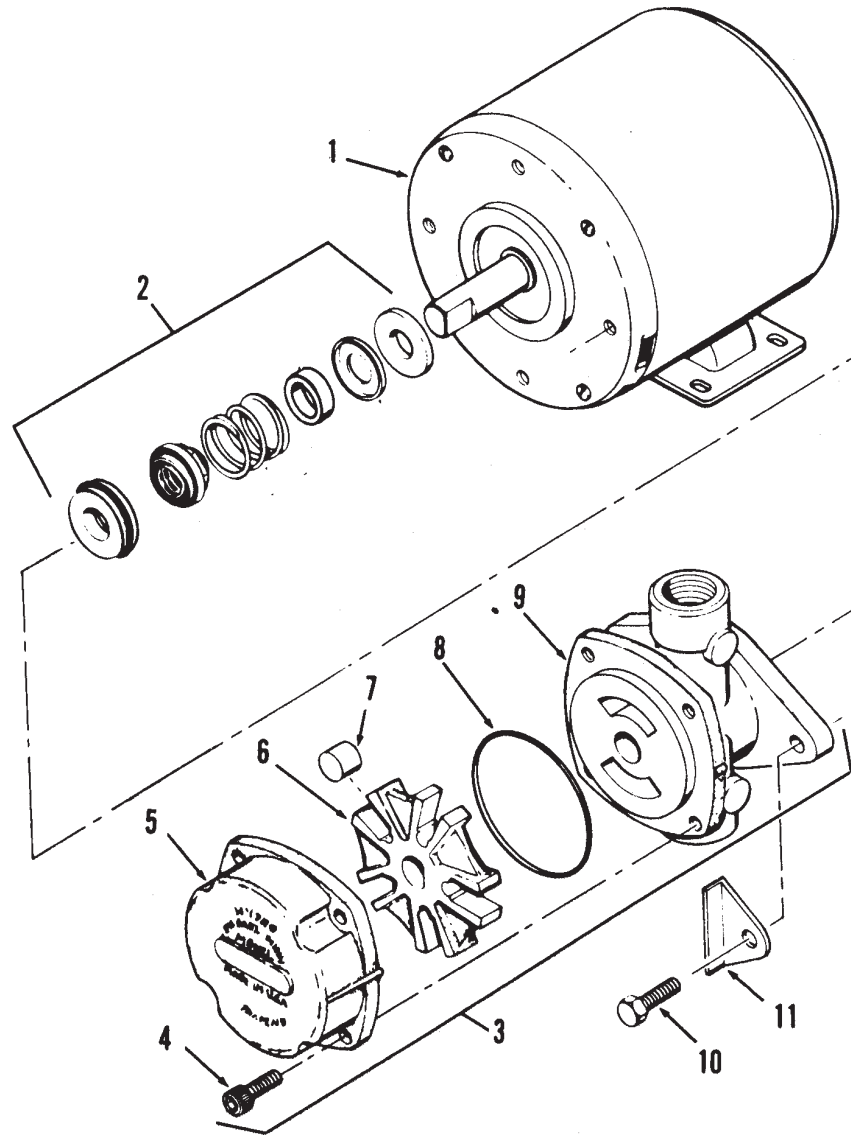

Filter Motor and Pump

Item No.	Part No.	Description	Quantity
√ 1	67583	MOTOR, 1/2 HP - 50/60 Hz.....	1
√ 2	17476	SEAL KIT.....	1
3	17437	PUMP ASSEMBLY.....	1
√ 4	SC01-132	SCREW, Pump Cover.....	1
√ 5	17451	COVER, Pump.....	1
√ 6	17447	ROTOR, Pump.....	1
√ 7	17446	ROLLER, Pump.....	5
√ 8	17453	O-RING.....	1
√ 9	17454	BODY, Pump.....	1
√ 10	17456	SHIELD, Pump.....	2
√ 11	SC01-026	SCREW, Pump Shield.....	1

√ recommended parts

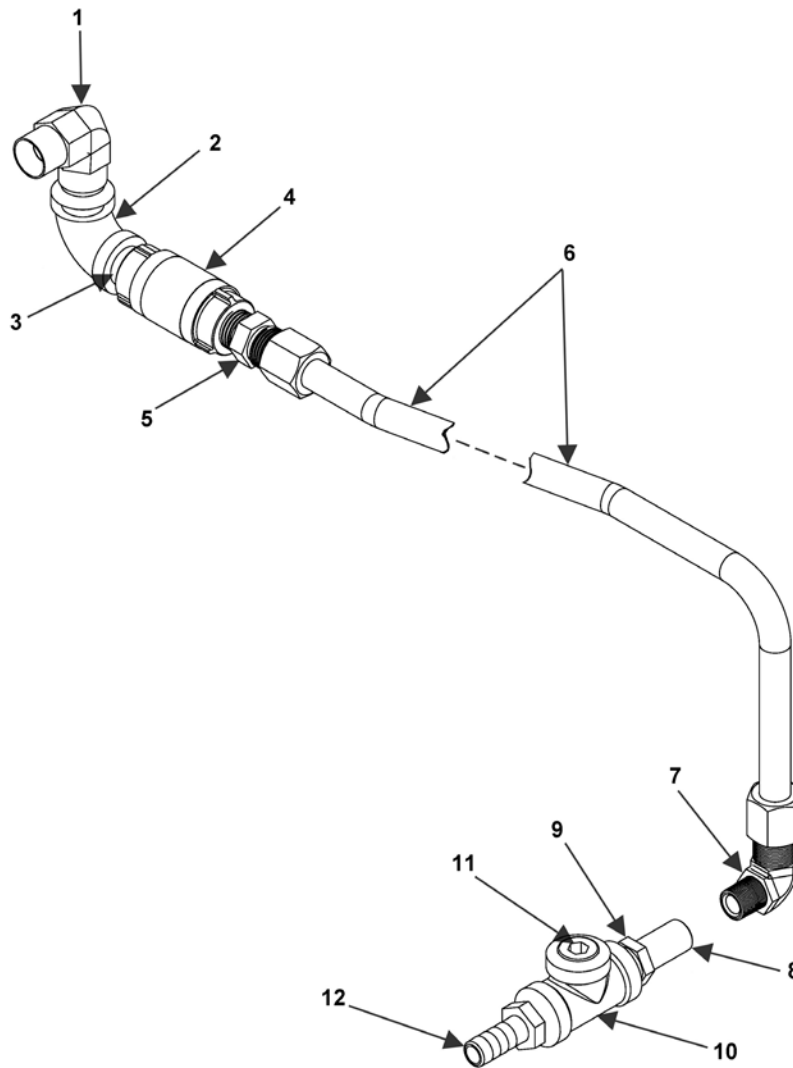

Piping Assembly - Units Without RTI

Item No.	Part No.	Description	Quantity
	85571-001	ASSY-Piping, Manifold to JIB Pump - LVG-103 & 104	1
	85571-002	ASSY-Piping, Manifold to JIB Pump - LVG-102.....	1
1	FP01-118	ELBOW-5/8 TUBE-1/2 NPT FEMALE.....	1
2	FP01-090	ELBOW-1/2NPT X 90 FEMALE BI.....	1
3	35856	NIPPLE -1 1/8 SHORT HOSPITAL - LVG-103 & 104	1
3	18816	NIPPLE - 1/2 X 3 SS PIPE - LVG-102	1
4	74469	VALVE-1/2 CHECK.....	1
5	16807	FITTING CONNECTOR MALE	1
6	78095	ASSY-JIB PUMP CHECK VALVE - LVG-103 & 104	1
6	78160	ASSY-JIB PUMP CHECK VALVE SS - LVG-102.....	1
7	FP01-079	ELBOW 5/8 TUBE-3/8 NPT MALE.....	1
8	FP01-029	REDUCER 1/2NPT M-3/8NPT F SS	1
9	35475	PIPE NIPPLE 3/8 X 2.....	1
10	FP01-004	PLUG PIPE 1/2 HEX SOC SS	1
11	FP01-112	1/2 NPT FEMALE PIPE TEE BI	1
12	FP01-203	BARB-1/2 MPT 1/2 HOSE 304 SS.....	1

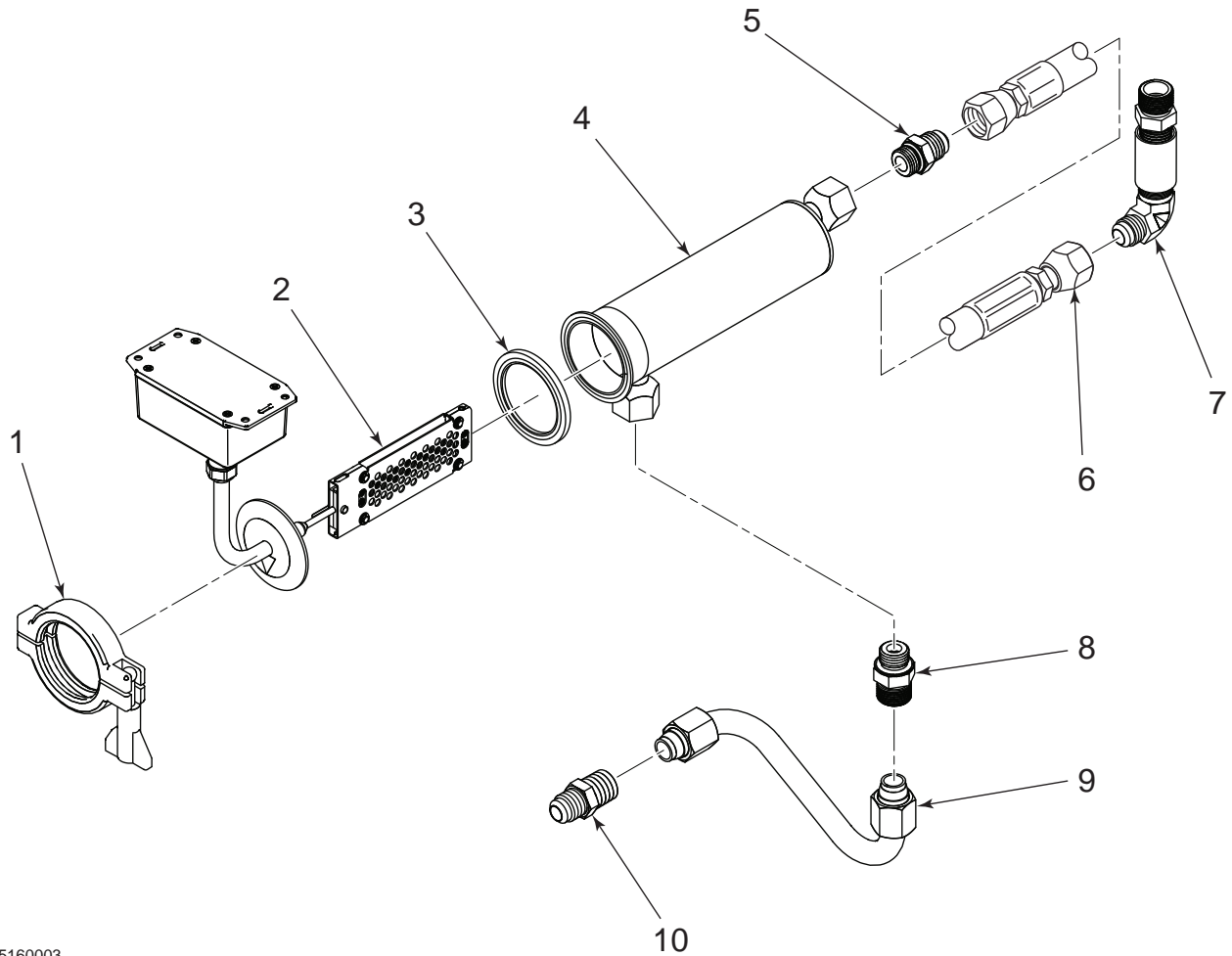

05160003

Oil Quality Monitoring (OQM) Sensor

Item No.	Part No.	Description	Quantity
1	154103	CLAMP, SENSOR OQM.....	1
2	154101	ASSY, OQM SENSOR & TUBE.....	1
3	154104	SEAL, SENSOR OQM.....	1
4	154102	WELD ASSY, OQM SENSOR BODY.....	1
5	FP01-307	ADPT-SAE8 ORBM 1/2 M JIC45 FLR	1
6	151686-002	HOSE, OIL DISPOSAL 34in. (86.36cm).....	1
7	163909	ASSY-OQM PLUMBING HOSE TO MANF	1
8	FP01-338	FITTING-#8 SAE ORB X 5/8 COMP	1
9	154826	TUBE, PUMP TO OQM SENSOR	1
10	16807	FITTING, CONNECTOR, MALE	1

APPENDIX A. WIRING DIAGRAMS AND SCHEMATICS

A-1. WIRING DIAGRAMS AND SCHEMATICS

APPENDIX A contains the wiring diagrams and schematics to support the LVG-100 series fryers.

