



**Henny Penny
Open Fryer
(Full & Split Vat)**

- | | |
|--------------|--------------------|
| Model | OFE/OFG-321 |
| Model | OFE/OFG-322 |
| Model | OFE/OFG-323 |
| Model | OFE/OFG-324 |
| Model | OEA/OGA-321 |
| Model | OEA/OGA-322 |
| Model | OEA/OGA-323 |
| Model | OEA/OGA-324 |
| Model | ODE/ODG-323 |

OPERATOR'S MANUAL

REGISTER WARRANTY ONLINE AT WWW.HENNYPENNY.COM

LIMITED WARRANTY FOR HENNY PENNY EQUIPMENT

Subject to the following conditions, Henny Penny Corporation makes the following limited warranties to the original purchaser only for Henny Penny appliances and replacement parts:

NEW EQUIPMENT: Any part of a new appliance, except baskets, lamps, and fuses, which proves to be defective in material or workmanship within two (2) years from date of original installation, will be repaired or replaced without charge F.O.B. factory, Eaton, Ohio, or F.O.B. authorized distributor. Baskets will be repaired or replaced for ninety (90) days from date of original installation. Lamps and fuses are not covered under this Limited Warranty. To validate this warranty, the registration card for the appliance must be mailed to Henny Penny within ten (10) days after installation.

FILTER SYSTEM: Failure of any parts within a fryer filter system caused by the use of the non-OEM filters or other unapproved filters is not covered under this Limited Warranty.

REPLACEMENT PARTS: Any appliance replacement part, except lamps and fuses, which proves to be defective in material or workmanship within ninety (90) days from date of original installation will be repaired or replaced without charge F.O.B. factory, Eaton, Ohio, or F.O.B. authorized distributor.

The warranty for new equipment covers the repair or replacement of the defective part and includes labor charges and maximum mileage charges of 200 miles round trip for a period of one (1) year from the date of original installation.

The warranty for replacement parts covers only the repair or replacement of the defective part and does not include any labor charges for the removal and installation of any parts, travel, or other expenses incidental to the repair or replacement of a part.

EXTENDED FRYPOT WARRANTY: Henny Penny will replace any frypot that fails due to manufacturing or workmanship issues for a period of up to seven (7) years from date of manufacture. This warranty shall not cover any frypot that fails due to any misuse or abuse, such as heating of the frypot without shortening.

0 TO 3 YEARS: During this time, any frypot that fails due to manufacturing or workmanship issues will be replaced at no charge for parts, labor, or freight. Henny Penny will either install a new frypot at no cost or provide a new or reconditioned replacement fryer at no cost.

3 TO 7 YEARS: During this time, any frypot that fails due to manufacturing or workmanship issues will be replaced at no charge for the frypot only. Any freight charges and labor costs to install the new frypot as well as the cost of any other parts replaced, such as insulation, thermal sensors, high limits, fittings, and hardware, will be the responsibility of the owner.

Any claim must be presented to either Henny Penny or the distributor from whom the appliance was purchased. No allowance will be granted for repairs made by anyone else without Henny Penny's written consent. If damage occurs during shipping, notify the sender at once so that a claim may be filed.

THE ABOVE LIMITED WARRANTY SETS FORTH THE SOLE REMEDY AGAINST HENNY PENNY FOR ANY BREACH OF WARRANTY OR OTHER TERM. BUYER AGREES THAT NO OTHER REMEDY (INCLUDING CLAIMS FOR ANY INCIDENTAL OR CONSEQUENTIAL DAMAGES) SHALL BE AVAILABLE.

The above limited warranty does not apply (a) to damage resulting from accident, alteration, misuse, or abuse; (b) if the equipment's serial number is removed or defaced; or (c) for lamps and fuses. THE ABOVE LIMITED WARRANTY IS EXPRESSLY IN LIEU OF ALL OTHER WARRANTIES, EXPRESS OR IMPLIED, INCLUDING MERCHANTABILITY AND FITNESS, AND ALL OTHER WARRANTIES ARE EXCLUDED. HENNY PENNY NEITHER ASSUMES NOR AUTHORIZES ANY PERSON TO ASSUME FOR IT ANY OTHER OBLIGATION OR LIABILITY.

Revised 01/01/07

NOTICE

This manual should be retained in a convenient location for future reference.

A wiring diagram for this appliance is located on the inside of the right side panel.

Post in a prominent location, instructions to be followed in event user smells gas. This information shall be obtained by consulting the local gas supplier.

Do not obstruct the flow of combustion and ventilation air. Adequate clearance must be left all around appliance for sufficient air to the combustion chamber.

The Model OFG/OGA-32X open fryer is equipped with a continuous pilot. But the open fryer cannot be operated without electric power. The unit will automatically return to normal operation when power is restored.

CAUTION

To avoid a fire, keep appliance area free and clear from combustibles.



Improper installation, adjustment, alteration, service, or maintenance can cause property damage, injury, or death. Read the installation, operating, and maintenance instructions thoroughly before installing or servicing this equipment.



DO NOT STORE OR USE GASOLINE OR OTHER FLAMMABLE VAPORS AND LIQUIDS IN THE VICINITY OF THIS OR ANY OTHER APPLIANCE. FIRE OR EXPLOSION COULD RESULT.

Technical Data for CE/AGA Marked Products

Nominal Heat Input: (Net)	Natural (I _{2H}) = 24.9 KW (85,000 Btu/h)
	Natural (I _{2E}) = 24.9 KW (85,000 Btu/h)
	Natural (I _{2E+}) = 24.9 KW (85,000 Btu/h)
	Natural (I _{2L}) = 24.9 KW (85,000 Btu/h)
	Liquid Propane (I _{3P}) = 24.9 KW (85,000 Btu/h)
Nominal Heat Input: (Gross)	Natural (I _{2H}) = 27.7 KW (99.70 MJ/h) (94,500 Btu/h)
	Natural (I _{2E}) = 27.7 KW (94,500 Btu/h)
	Natural (I _{2E+}) = 27.7 KW (94,500 Btu/h)
	Natural (I _{2L}) = 27.7 KW (94,500 Btu/h)
	Liquid Propane (I _{3P}) = 27.7 KW (99.70 MJ/h) (94,500 Btu/h)
Supply Pressure:	Natural (I _{2H}) = 20 mbar (2.0 kPa)
	Natural (I _{2E}) = 20 mbar
	Natural (I _{2E+}) = 20/25 mbar
	Natural (I _{2L}) = 25 mbar
	Liquid Propane (I _{3P}) = 30 mbar
	Liquid Propane (I _{3P}) = 37 mbar (3.7 kPa)
Test Point Pressure:	Liquid Propane (I _{3P}) = 50 mbar (5.0 kPa)
	Natural (I _{2H}) = 8.7 mbar (0.87 kPa)
	Natural (I _{2E}) = 8.7 mbar
	Natural (I _{2E+}) = N/A
	Natural (I _{2L}) = 10 mbar
	Liquid Propane (I _{3P}) = 24.5 mbar (2.5 kPa)
Injector Size:	Natural (I _{2H}) = 3.26 mm
	Natural (I _{2E}) = 3.26 mm
	Natural (I _{2E+}) = 2.70 mm
	Natural (I _{2L}) = 3.26 mm
	Liquid Propane (I _{3P}) = 1.93 mm

This appliance must be installed in accordance with the manufacturer's instructions and the regulations in force and only used in a suitably ventilated location. Read the instructions fully before installing or using the appliance.

Noise generated from this equipment is less than 70 dB(A)

TABLE OF CONTENTS

Section	Page
Section 1. INTRODUCTION	1-1
1-1. Introduction.....	1-1
1-2. Features.....	1-1
1-3. Proper Care	1-1
1-4. Assistance	1-1
1-5. Safety	1-2
Section 2. INSTALLATION	2-1
2-1. Introduction.....	2-1
2-2. Unpacking.....	2-1
2-3. Selecting the Location	2-2
2-4. Leveling the Open Fryer	2-2
2-5. Ventilation of Open Fryer.....	2-2
2-6. Gas Supply.....	2-3
2-7. Gas Leak Test	2-6
2-8. Gas Pressure Regulator Setting.....	2-6
2-9. Electrical Requirements OFG-320 Series.....	2-6
2-10. Electrical Requirements OFE-320 Series	2-7
2-11. Testing the Fryer	2-8
2-12. Joining Instructions	2-8
Section 3. OPERATION.....	3-1
3-1. Operating Components C1000 Controls.....	3-1
3-2. Operating Components 6 & 12 Button Controls	3-3
3-3. Clock Set.....	3-7
3-4. Filling or Adding Shortening.....	3-9
3-5. C1000 Operations and Procedures.....	3-10
3-6. C1000 Programming Instructions.....	3-11
3-7. C1000 Special Programming	3-12
3-8. Basic Operations and Procedures (6 Product Controls).....	3-13
3-9. Basic Operations and Procedures (12 Product Controls/Auto-Lift)	3-15
3-10. Care of Shortening.....	3-17
3-11. Filtering of Shortening.....	3-18
3-12. Filter Pump Problem Prevention.....	3-22
3-13. Filter Pump Motor Protector - Manual Reset	3-22
3-14. Changing the Filter Envelope	3-22
3-15. Cleaning the Frypot	3-24
3-16. Clean-Out Mode	2-26
3-17. Operating Instructions for Optional Direct-Connect Shortening System.....	3-27
3-18. Lighting and Shutdown of the Burners.....	3-28
3-19. High Temperature Limit Control.....	3-29
3-17. Regular Maintenance	3-29

TABLE OF CONTENTS

Section	Page
Section 4. PROGRAMMING – 6 & 12 PRODUCT CONTROLS	4-1
4-1. Introduction.....	4-1
4-2. Product Program Mode.....	4-1
4-3. Special Program Mode.....	4-4
4-4. Data Logging, Heat Control, Tech, and Stat Modes.....	4-15
Section 5. TROUBLESHOOTING.....	5-1
5-1. Troubleshooting Guide	5-1
5-2. Error Codes	5-2
Section 6. INFORMATION MODE.....	6-1
GLOSSARY	G-1

Distributors List - Domestic and International

SECTION 1. INTRODUCTION

1-1. INTRODUCTION

The Henny Penny Open Fryer is a basic unit of food equipment designed to cook foods better and easier. The microcomputer-based design helps make this possible. This unit is used only in institutional and commercial food service operations.

NOTICE

As of August 16, 2005, the Waste Electrical and Electronic Equipment directive went into effect for the European Union. Our products have been evaluated to the WEEE directive. We have also reviewed our products to determine if they comply with the Restriction of Hazardous Substances directive (RoHS) and have redesigned our products as needed in order to comply. To continue compliance with these directives, this unit must not be disposed as unsorted municipal waste. For proper disposal, please contact your nearest Henny Penny distributor.



1-2. FEATURES

- Easily cleaned
- Full frypot 65 lbs. (29.5 kg.) shortening capacity
- Split frypot 25 lbs. (11.3 kg.) shortening cap. (elec. only)
- 2 Half size baskets per well (or full size baskets)
- Stainless steel construction
- Manual reset high limit control
- Self-diagnostic system built into controls
- Built in filter (handles all 3 wells)
- Propane or natural gas; 85,000 btu/pot (26.38 kw)
- Energy Save Mode upon activation for gas fryers
- Many combinations of split frypot/full frypot fryers
- Simplistic electronic Computron 1000 controls available, or more diverse multifunctional controls available

1-3. PROPER CARE

As in any unit of food servicing equipment, the open fryer does require care and maintenance. Requirements for the maintenance and cleaning are contained in this manual and must become a regular part of the operation of the unit at all times.

1-4. ASSISTANCE

Should you require outside assistance, call your local independent Henny Penny distributor in your area, call Henny Penny Corp. at 1-800-417-8405 or 1-937-456-8405, or go to Henny Penny online at www.hennypenny.com.

1-5. SAFETY

The Henny Penny Open Fryer has many safety features incorporated. However, the only way to ensure safe operation is to fully understand the proper installation, operation, and maintenance procedures. The instructions in this manual have been prepared to aid you in learning the proper procedures.

This appliance is not intended for use by persons (including children) with reduced physical, sensory or mental capabilities, or lack of experience and knowledge, unless they have been given supervision or instruction concerning use of the appliance by a person responsible for their safety.

Where information is of particular importance or is safety related, the words DANGER, WARNING, CAUTION, or NOTE are used. Their usage is described below:



SAFETY ALERT SYMBOL is used with DANGER, WARNING or CAUTION which indicates a personal injury type hazard.



NOTICE is used to highlight especially important information.



CAUTION used without the safety alert symbol indicates a potentially hazardous situation which, if not avoided, may result in property damage.



CAUTION used with the safety alert symbol indicates a potentially hazardous situation which, if not avoided, could result in minor or moderate injury.



WARNING indicates a potentially hazardous situation which, if not avoided, could result in death or serious injury.



DANGER INDICATES AN IMMINENTLY HAZARDOUS SITUATION WHICH, IF NOT AVOIDED, WILL RESULT IN DEATH OR SERIOUS INJURY.

1-5. SAFETY (Continued)



Equipotential Ground Symbol



Waste Electrical and Electronic Equipment (WEEE) Symbol



or



Shock Hazard Symbols



or



Hot Surface Symbols

SECTION 2. INSTALLATION

2-1. INTRODUCTION

This section provides the installation instructions for the Henny Penny Open Fryer.

NOTICE

Installation of the unit should be performed only by a qualified service technician.



Do not puncture the unit with any objects such as drills or screws as component damage or electrical shock could result.

2-2. UNPACKING

The Henny Penny Open Fryer has been tested, inspected, and expertly packed to ensure arrival at its destination in the best possible condition. The unit is banded to a wooden skid and then packed inside a heavy cardboard carton with sufficient padding to withstand normal shipping treatment.

NOTICE

Any shipping damage should be noted in the presence of the delivery agent and signed prior to his or her departure.

1. Carefully cut bands from cardboard carton.
2. Lift carton from the unit.
3. Cut and remove the metal bands holding the fryer to the pallet.
4. Remove the fryer from the pallet.



Take care when moving the fryer to prevent personal injury. The fryer can weigh between 305 lbs. (138 kg) and 616 lbs. (279 kg).

2-3. SELECTING THE LOCATION

The proper location of the open fryer is very important for the duration, speed, and convenience. The location of the open fryer should allow clearances for servicing and proper operation. Choose a location which will provide easy loading and unloading without interfering with the final assembly of food orders. Operators have found that frying from raw to finish, and holding the product in warmers provides fast continuous service. Keep in mind, the best efficiency will be obtained by a straight line operation, i.e., raw in one side and finished out the other side. Order assembly can be moved away with only a slight loss of efficiency.



To prevent severe burns from splashing hot shortening, position and install fryer to prevent tipping or movement. Restraining ties may be used for stabilization.



To avoid fire, install the open fryer with minimum clearance from all combustible and noncombustible materials, 4 inches (10.16 cm) from the side and 4 inches (10.16 cm) from the back. If installed properly, the open fryer is designed for operation on combustible floors and adjacent to combustible walls.

Do not spray aerosols in the vicinity of this appliance while it is in operation.

2-4. LEVELING THE OPEN FRYER

For proper operation, the open fryer should be level from side to side and front to back. Using a level placed on the flat areas around the frypot collar, on the middle well, adjust the casters until the unit is level.

2-5. VENTILATION OF OPEN FRYER

The open fryer should be located with provision for venting into an adequate exhaust hood or ventilation system. This is essential to permit efficient removal of the steam exhaust and frying odors. Special precaution must be taken in designing an exhaust canopy to avoid interference with the operation of the open fryer. We recommend you consult a local ventilation or heating company to help in designing an adequate system.

**2-5. VENTILATION OF OPEN
FRYER
(Continued)**



Ventilation must conform to local, state, and national codes. Consult your local fire department or building authorities.



When installing the gas open fryer, do not attach an extension to the gas flue exhaust stack. This may impair proper operation of the burner, causing malfunctions and possible negative back draft.

2-6. GAS SUPPLY

The gas open fryer is factory available for either natural or propane gas. Check the data plate inside the front door of the cabinet to determine the proper gas supply requirements. The minimum supply for natural gas is 7 inches water column (1.7 kPa), and 10 inches water column (2.49 kPa) for propane.



Do not attempt to use any gas other than that specified on the data plate. Incorrect gas supply could cause a fire or explosion resulting in severe injuries and/or property damage.

Please refer below for the recommended hookup of the fryer to main gas line supply.



To avoid possible serious personal injury:

- **Installation must conform with local, state, and national codes, the American National Standard Z223.1-(the latest edition) National Fuel Gas Code, and the local municipal building codes. In Canada, installation must be in accordance with Standard CAN/CSA B 149.1 & Installation Codes - Gas Burning Appliances and local codes. In Australia, in accordance with Australian Gas Authority rules AS5601.1/2-2010.**

2-6. GAS SUPPLY
(Continued)

- **The fryer and its manual shutoff valve must be disconnected from the gas supply piping system during any pressure testing of that system at test pressures in excess of ½ PSIG (3.45 kPa) (34.5 mbar).**
- **The fryer must be isolated from the gas supply piping system by closing its individual manual shutoff valve during any pressure testing of the gas supply piping system at test pressures equal to or less than ½ PSIG (3.45 kPa) (34.5 mbar).**
- **A standard one inch (2.54 cm), black steel pipe and malleable fittings should be used for gas service connections for 3 well open fryers, ¾ inch (1.91 cm) for 2 wells, and ½ inch (1.27 cm) for single wells.**
- **Do not use cast iron fittings.**
- **Although one inch (2.54 cm) size pipe is recommended for 3 wells, ¾ inch (1.91 cm) for 2 wells, and ½ inch (1.27 cm) for single wells, piping should be of adequate size and installed to provide a supply of gas sufficient to meet the maximum demand without undue loss of pressure between the meter and the open fryer. The pressure loss in the piping system should not exceed 0.3 in. water column (0.747 mbar).**

Provisions should be made for moving the open fryer for cleaning and servicing. This may be accomplished by:

1. Installing a manual gas shut off valve and a disconnect union, or
2. Installing a heavy-duty design A.G.A. certified connector. In order to be able to service this appliance, which is provided with casters, a connector complying with ANSI Z21.69 or CAN 1-6.10m88 and a quick-disconnect device, complying with ANSI Z21.41 or CAN 1-6.9m70, must be installed. It must also be installed with restraining means to guard against transmission of strain to the connector as specified in the appliance manufacturer's instruction.
3. See the illustration on the following page for the proper connection of flexible gas line and cable restraint.

NOTICE

The cable restraint limits the distance the open fryer can be pulled from the wall. For cleaning and servicing the unit, the cable must be unsnapped from the open fryer and the flexible gas line disconnected. This will allow better access to all sides of the open fryer. The gas line and cable restraint must be reconnected once the cleaning or servicing is complete.

2-6. GAS SUPPLY
(Continued)

For Australia or New Zealand: Where a model is supplied with castors and is to be connected to a fixed gas supply via a flexible hose connection, a restraining chain or wire of adequate strength shall be fixed to the appliance and be suitable to be fixed to the wall within 50 mm of each connection point. The length of the chain or wire shall not exceed 80% of the length of the hose assembly.

GAS PIPING

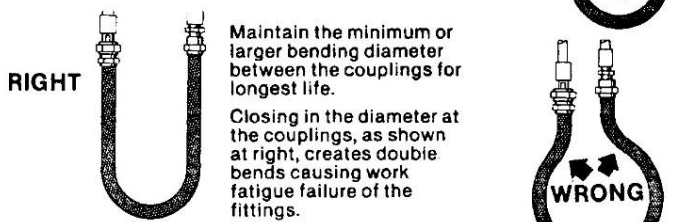
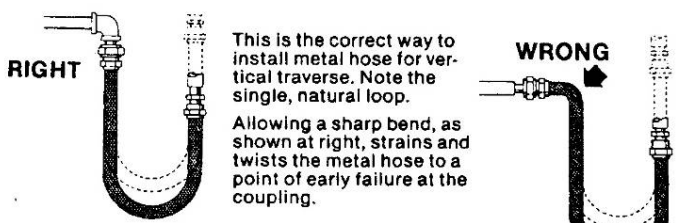
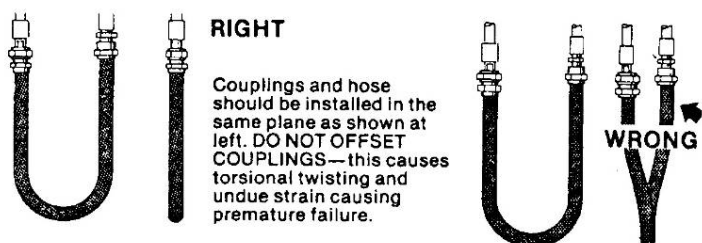
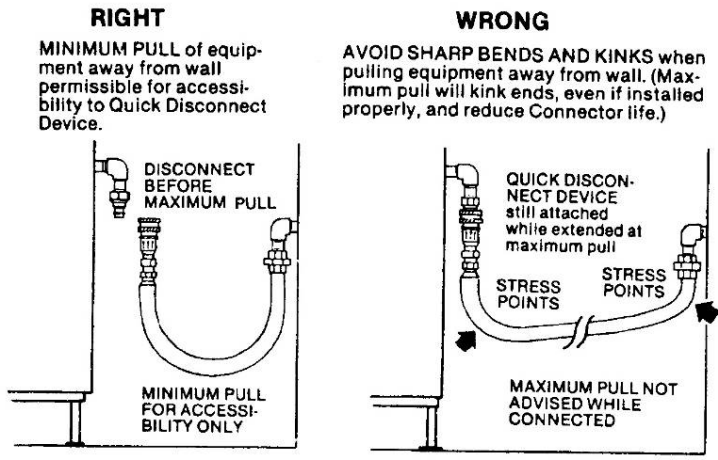

CABLE RESTRAINT

Please refer to the illustration below when installing cable restraint on all moveable gas fryers.

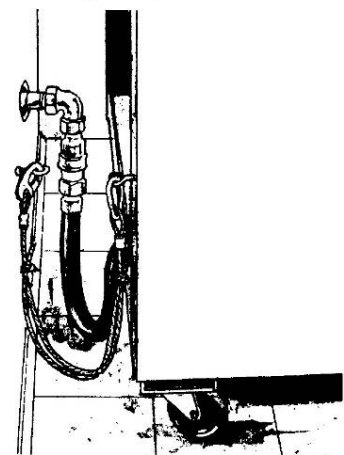

I-bolt is to be secured to the building using acceptable building construction practices.

CAUTION

DRY WALL CONSTRUCTION
Secure I-bolt to a building stud. Do not attach to dry wall only. Also, locate the I-bolt at the same height as the gas service. Preferred installation is approximately six inches to either side of service. Cable restraint must be at least six inches shorter than flexible gas line.

CAUTION

Utilize elbows when necessary to avoid sharp kinks or excessive bending. For ease of movement, install with a "lazy" loop. Gas appliance must be disconnected prior to maximum movement. (Minimum movement is permissible for hose disconnection).

2-7. GAS LEAK TEST

NOTICE

Prior to turning the gas supply on, be sure the gas valve knob on the gas control valve is in the OFF position.

Upon initial installation, and after moving the unit, the piping and fittings should be checked for gas leaks. A simple checking method is to turn on the gas and brush all connections with a soap solution. If bubbles occur, it indicates escaping gas. In this event, the piping connection must be redone.



To avoid fire or explosion, never use a lighted match or open flame to test for gas leaks. Ignited gas could result in severe personal injury and/or property damage.

2-8. GAS PRESSURE REGULATOR SETTING

The gas pressure regulator on the gas control valve is factory set as follows:

- Natural: 3.5 inches water column (0.87 mbar).
- Propane 10.0 inches water column (2.49 mbar).

NOTICE

The gas pressure regulator has been set by Henny Penny and is not to be adjusted by the user.

2-9. ELECTRICAL REQUIREMENTS OFG-320 SERIES

- 120 V, 50/60 Hz., 1 PH, 12 A
- 230 V, 50 Hz., 1 PH, 6 A

The 120 V gas open fryer requires a 3 wire grounded (earthed) service and is supplied with a grounded cord and plug. Any 230 volt plug used on the 230 volt unit must conform to all local, state, and national codes.



To avoid electrical shock, this appliance must be equipped with an external circuit breaker which incorporates a 3mm disconnection in all ungrounded (unearthed) conductors. The main power switch on this appliance does not disconnect all line conductors.

2-9. ELECTRICAL REQUIREMENTS
OFG-320 SERIES (Continued)



To avoid electrical shock, do not disconnect the ground (earth) plug. This fryer must be adequately and safely grounded (earthed). Refer to local electrical codes for correct grounding (earthing) procedures or in absence of local codes, with The National Electrical Code, ANSI/NFPA No. 70-(the current edition). In Canada, all electrical connections are to be made in accordance with CSA C22.1, Canadian Electrical Code Part 1, and/or local codes.

2-10. ELECTRICAL REQUIREMENTS
OFE-320 SERIES

Refer to the table below for supply wiring and fusing.

CABLE RESTRAINT

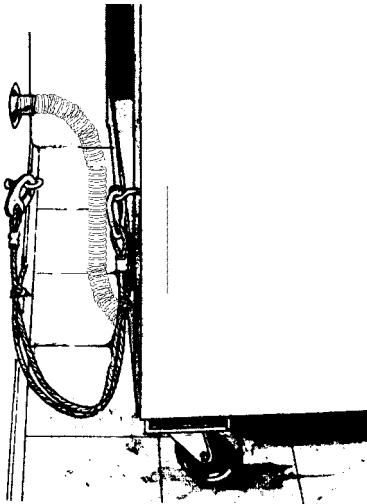

I-bolt is to be secured to the building using acceptable building construction practices.



DRYWALL CONSTRUCTION
Secure I-bolt to a building stud. Do not attach to drywall only. Preferred installation is approximately six inches to either side of service. Cable restraint must be at least six inches shorter than flexible conduit.

(Per Well)			
Volts	Phase	Kw	Amps
200-208	3	14.4	40
220/240	3	14.4	40
440-480	3	14.4	17
380-415	3	14.4	20



To avoid electrical shock, this appliance must be equipped with an external circuit breaker which will disconnect all ungrounded (unearthed) conductors. The main power switch on this appliance does not disconnect all line conductors.

To avoid electrical shock, this fryer must be adequately and safely grounded (earthed). Refer to local electrical codes for correct grounding (earthing) procedures or in absence of local codes, with The National Electrical Code, ANSI/NFPA No. 70-(the current edition). In Canada, all electrical connections are to be made in accordance with CSA C22.1, Canadian Electrical Code Part 1, and/or local codes.



CE units require a minimum wire size of 6 mm to be wired to the terminal block.

Permanently connected electric fryers with casters must be installed with flexible conduit and a cable restraint, when installed in the United States. See illustration at left. Holes are available in the rear fryer frame for securing the cable restraint to the fryer. The cable restraint does not prevent the fryer from tipping.

2-10. ELECTRICAL REQUIREMENTS
OFE-320 SERIES (Continued)

Additional CE Electrical Statements:

- The supply power cords shall be oil-resistant, sheathed flexible cable, no lighter than ordinary polychloroprene or other equivalent synthetic elastomer-sheathed cord, and must be HO7RN type.
- It is recommended that a 30 mA rated protective device such as a residual current circuit breaker (RCCB), or ground fault circuit interrupter (GFCI), be used on the fryer circuit.



(FOR EQUIPMENT WITH CE MARK ONLY!)
To prevent electric shock hazard this appliance must be bonded to other appliances or touchable metal surfaces in close proximity to this appliance with an equipotential bonding conductor. This appliance is equipped with an equipotential lug for this purpose. The equipotential lug is marked with the following symbol



2-11. TESTING THE FRYER

Each Henny Penny pressure fryer was completely checked and tested prior to shipment. However, it is good practice to check the unit for proper operation.

2-12. JOINING INSTRUCTIONS

The following instructions are for joining two units together. The instructions have part numbers in them. Please refer to figure 2-1 on the following page to visually match the numbers in the instructions below to the illustration.

1. Remove all hardware from the sides of the two open fryers.
2. Remove the right control panel assembly from the left unit and the left control panel assembly from the right unit.
3. Move the two units side by side with minimal gap.
4. Remove the right front caster from the left unit and the left rear caster from the right unit. Fasten both casters to the rear of the unit with wire ties (EF02-041).
5. Position the two open fryers by inserting bolts (SC01-227) thru the holes in top cover and the pot sides. Use washer (WA01-017) on both sides of the bolt when installing. **DO NOT TIGHTEN!**
6. Position front spacer (60554) between the front of the two open fryers. Place bolt (SC01-231), backed by washers (55350 & WA01-016), thru three holes in the frame capturing the spacer between the frames. Place washers (55350 & WA01-016) on bolt before installing nuts (NS02-010). **DO NOT TIGHTEN!**
7. Repeat with rear spacer (60555).
8. Tighten all fasteners securely.
9. Place cover (60593) over gap between open fryers.
10. Drill out dimples on rear shroud to 0.250 diameter holes.
11. Apply silicon around edge of unfinished side of rear cover (60599). Install rear cover (60599) with #8 nuts (NS02-007).

2-12. JOINING INSTRUCTIONS
(Continued)

12. Apply silicon around edge of unfinished side of top cover (60590) and basket rest cover (60591). Position top cover (60590) on open fryer top cover and install basket rest cover (60591) using #10 screws and nuts (SC01-074 & 60795).

13. Apply silicon to any gaps that may be left.

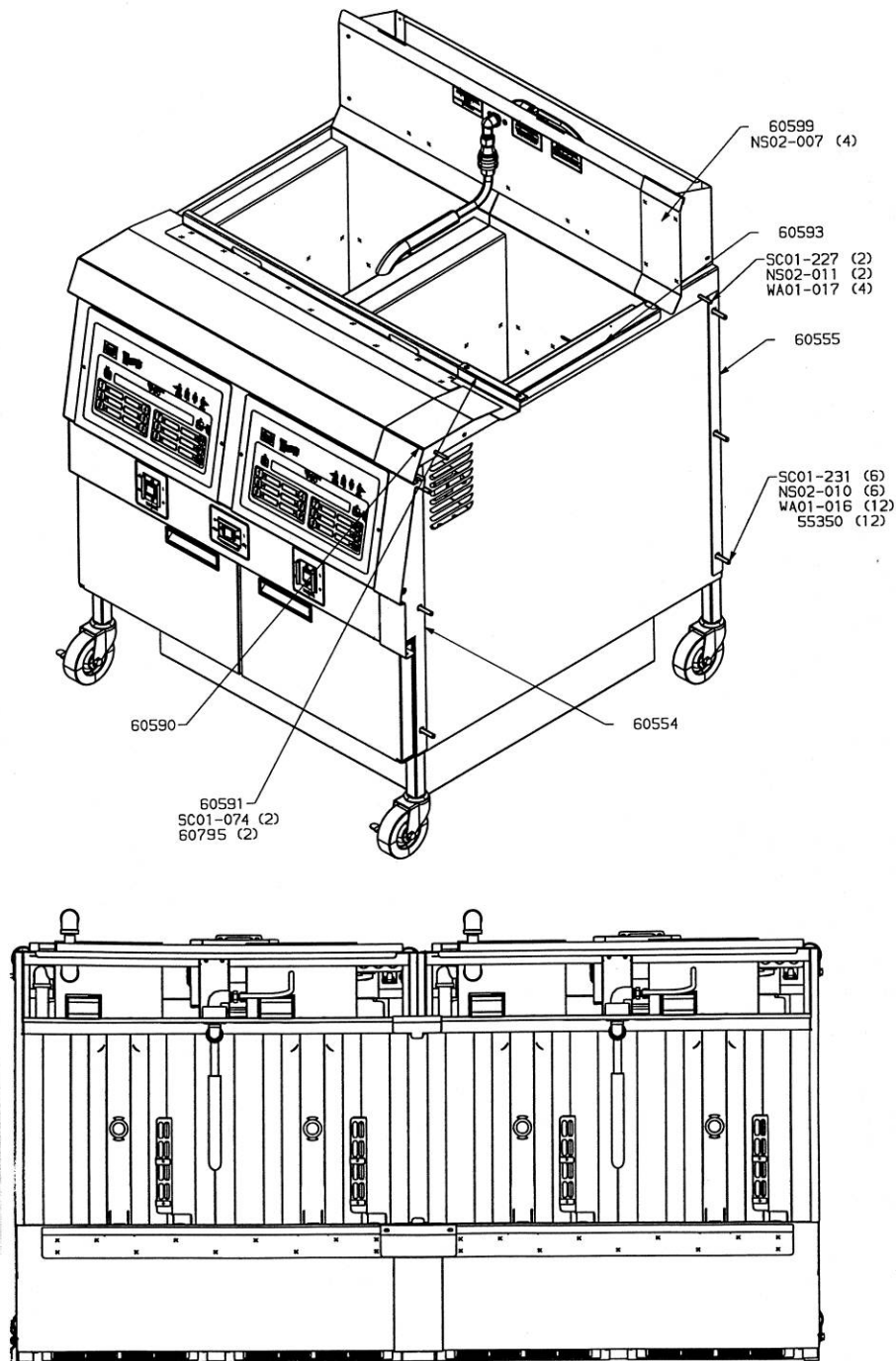
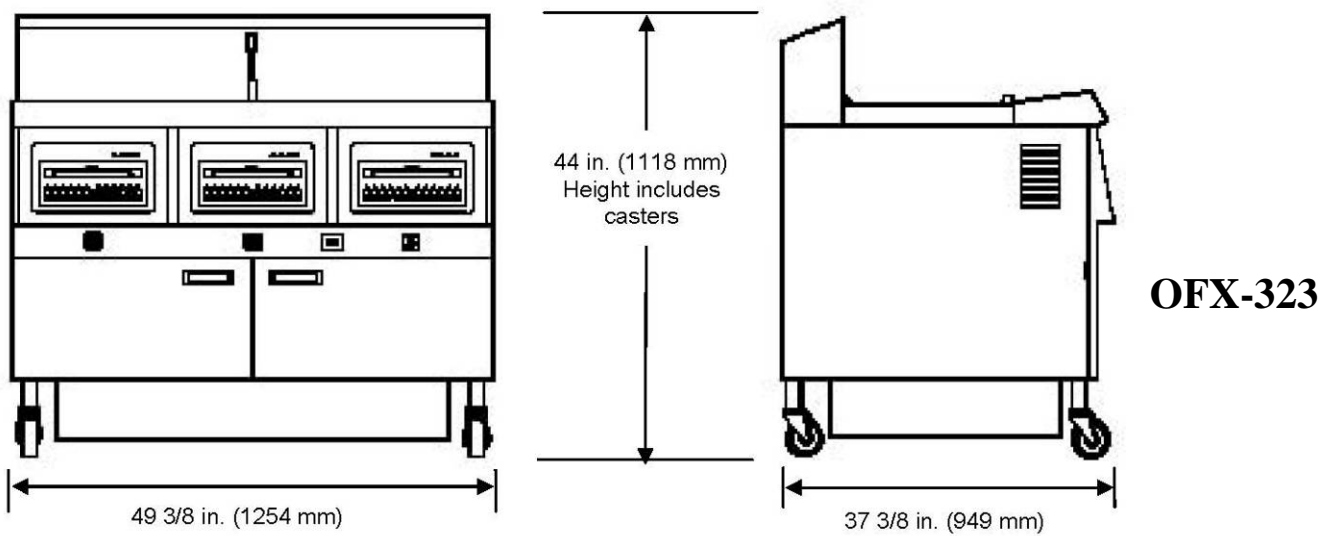
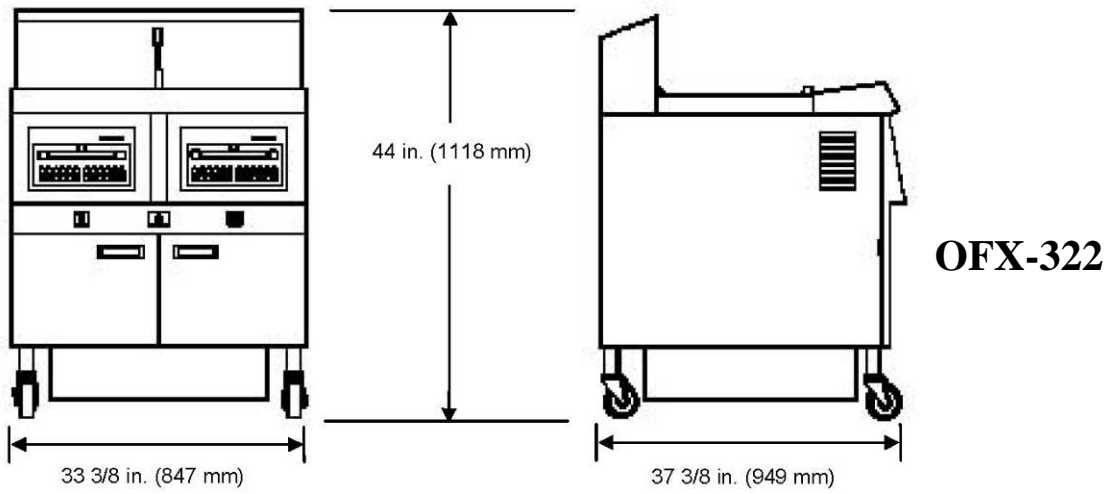
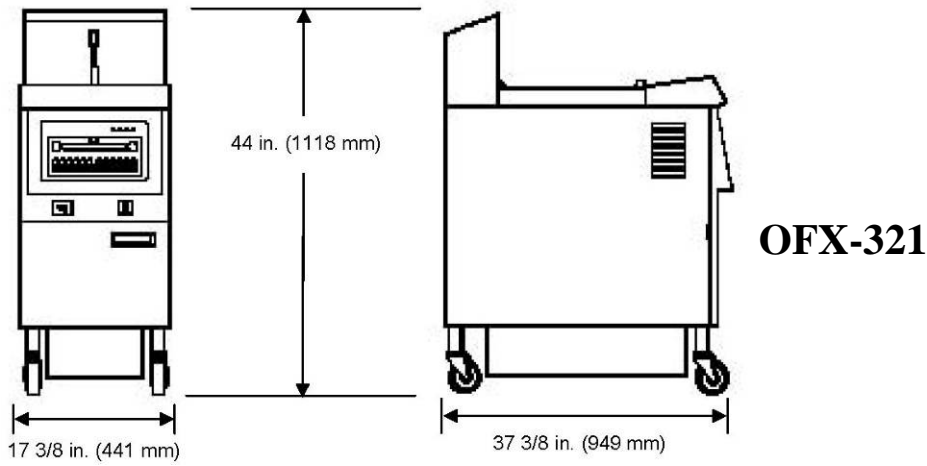

Figure 2-1

2-13. DIMENSIONS



2-13. DIMENSIONS (Continued)

OFG-32X Flue & Gas Line Dimensions
(All views are from rear of fryers)

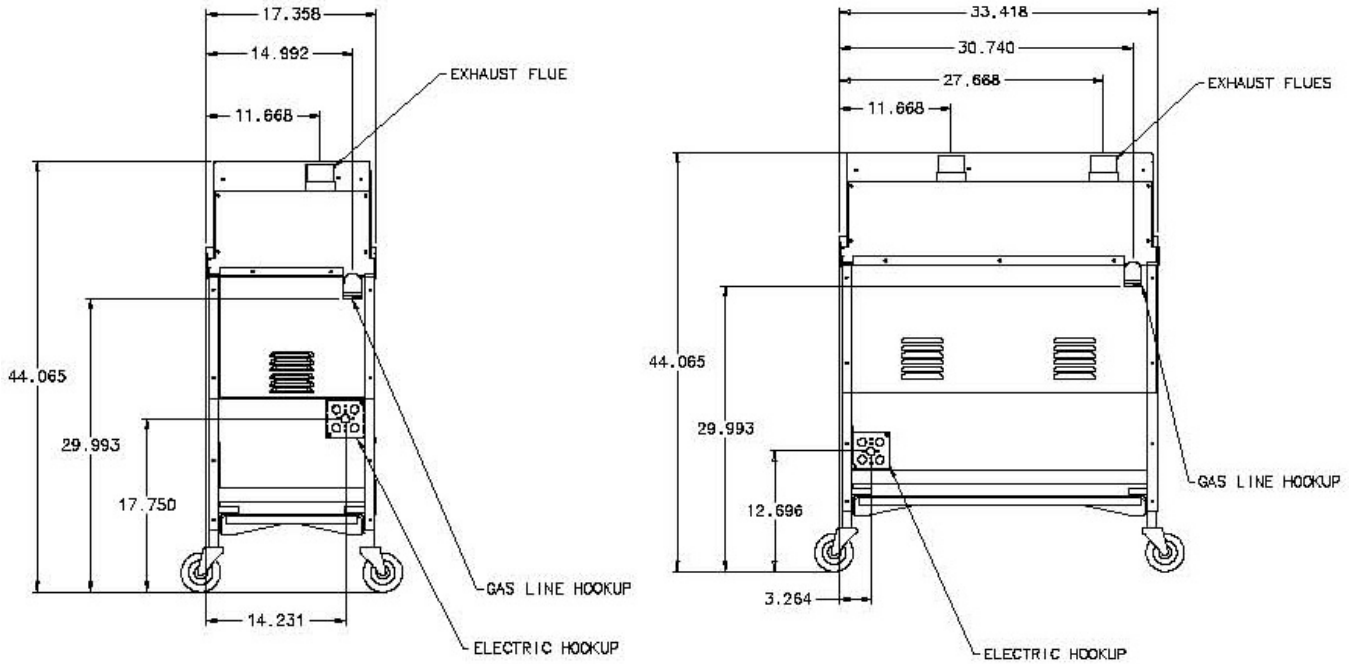

OFG-321

OFG-322

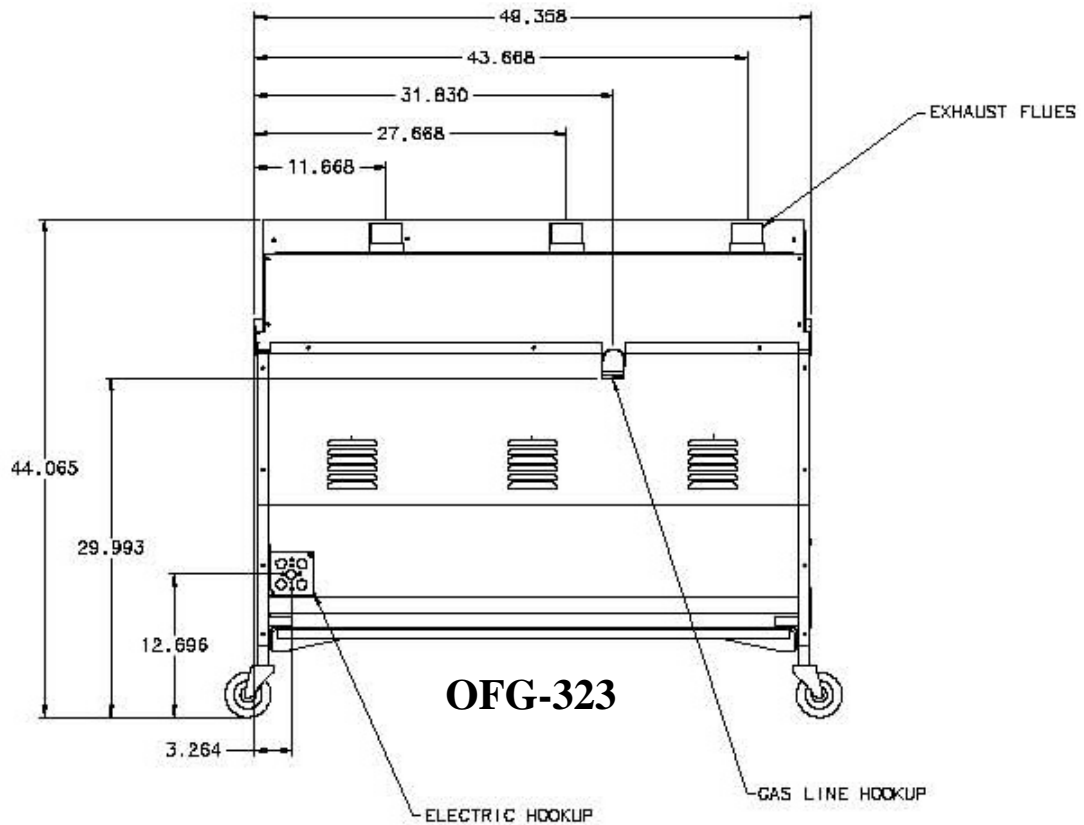







OFG-323

SECTION 3. OPERATION

3-1. OPERATING COMPONENTS
C1000 CONTROLS

Reference Figure 3-1.

Fig. No.	Item No.	Description	Function
3-1	1	Digital Display	Shows the shortening temperature, the timer countdown in the Cook Cycle, and the selections in the Program Mode; the temperature of the shortening can be shown by pressing P once, or twice to view set-point temperature; if shortening temperature exceeds 425°F (218°C), the display reads “E-5, FRYER TOO HOT”
3-1	2		This LED lights when the shortening temperature is within 5° of the setpoint temperature, signaling the operator that the shortening temperature is now at the proper temperature for dropping product into the frypot
3-1	3		The timer buttons are used to start and stop Cook Cycles
3-1	4		The idle buttons are used to start an Idle Mode which reduces the temperature of the shortening during non-use periods; press and hold to exit the Idle Mode
3-1	5		The program button is used to access the Program Modes; also, once in the Program Mode, it is used to advance to the next parameter
3-1	6 & 7		Used to adjust the value of the currently displayed setting in the Program Mode and to change set-point temperature for the left frypot, or basket
3-1	8 & 9		Used to adjust the value of the currently displayed setting in the Program Mode and to change set-point temperature for the right frypot, or basket

NOTICE

Proceed onto Section 3-4, Filling or Adding Shortening

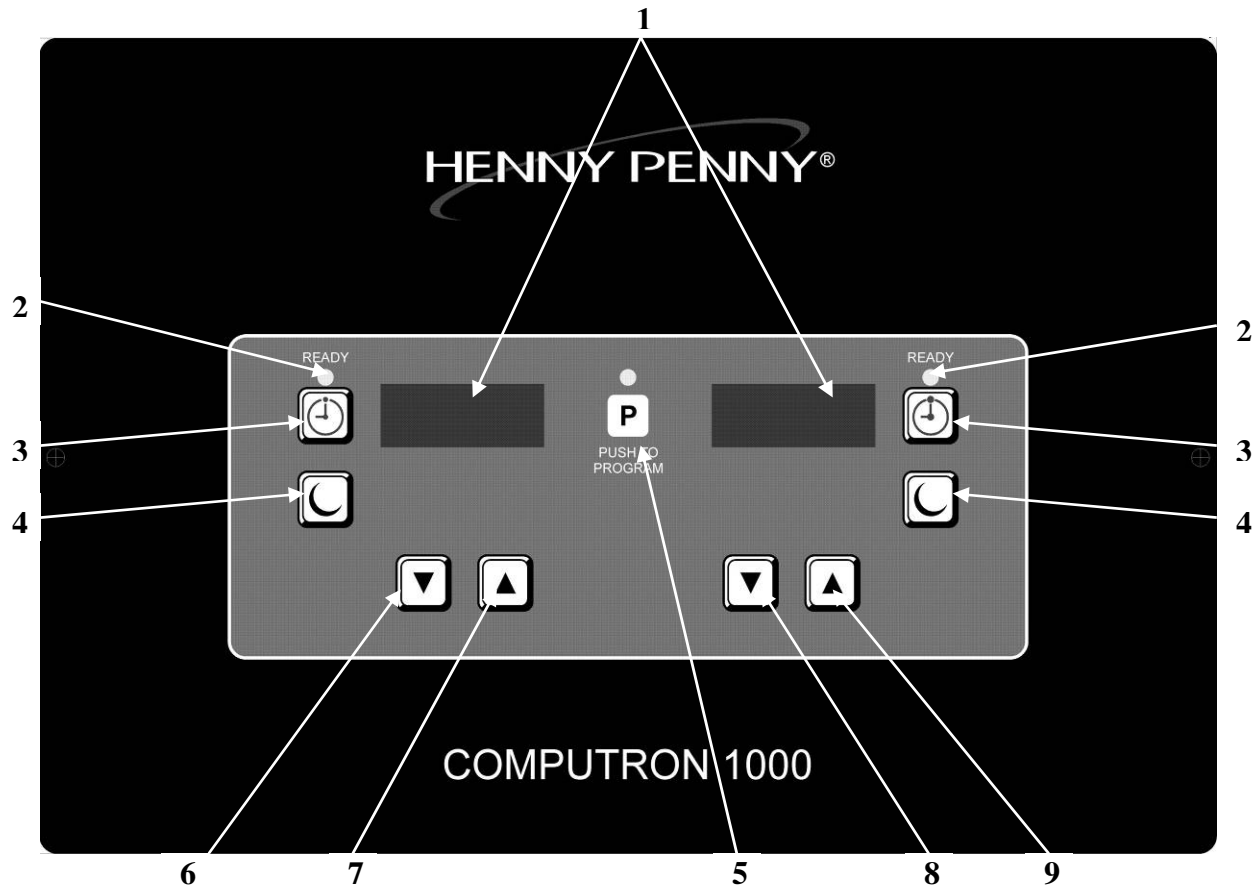







Figure 3-1

**3-2. OPERATING COMPONENTS
6 & 12 BUTTON CONTROLS**

Figure 3-2 shows the function of the 12 button timer control, and Figure 3-3 shows the function of the 6 button timer control.

Fig. No.	Item No.	Description	Function
3-1 3-2	1	 HEAT ON	This LED lights when the control calls for heat, and the burners come on and heat the shortening
3-1 3-2	2	Digital Displays	Shows the shortening temperature, the timer countdown in the Cook Cycle, and the selections in the Program Mode; the temperature of the shortening can be shown by depressing the INFO button; if the temperature exceeds 425°F (218°C), the display reads “E-5, FRYER TOO HOT”
3-1 3-2	3	WAIT LED	Once the open fryer is out of the Melt Cycle, this LED lights, signaling the operator that the shortening temperature is <u>not</u> at the proper temperature for dropping product into the frypot
3-1 3-2	4	READY LED	This LED lights when the shortening temperature is within 5° of the setpoint temperature, signaling the operator that the shortening temperature is now at the proper temperature for dropping product into the frypot
3-1 3-2	5	 INFO	Press to display the following fryer information and status: a. The temperature of the shortening b. The temperature setpoint c. Filter status d. The number of times filtered today e. The average no. of filters per day f. No. of times Cook Cycle was stopped early today g. No. of times Cook Cycle was stopped early in past week e. Date and time
3-1 3-2	6 & 7	 DOWN  UP	Used to adjust the value of the currently displayed setting in the Program Mode
3-1 3-2	8	 PROG	Used to access the Program Modes; also, once in the Program Mode, it is used to advance to the next parameter
3-1 3-2	9	START/STOP Button	Used to start and stop Cook Cycles; also de-activates the quality timer at the end of a Hold Mode
3-1 3-2	10	Menu Card Window	Displays the food product associated with each product selection button below; the menu card strip is located behind the decal
3-1 3-2	11	Product Select Buttons	Used to select which food products are to be cooked (on auto-lift open fryers, the 6 and 12 product buttons are basket lift buttons)

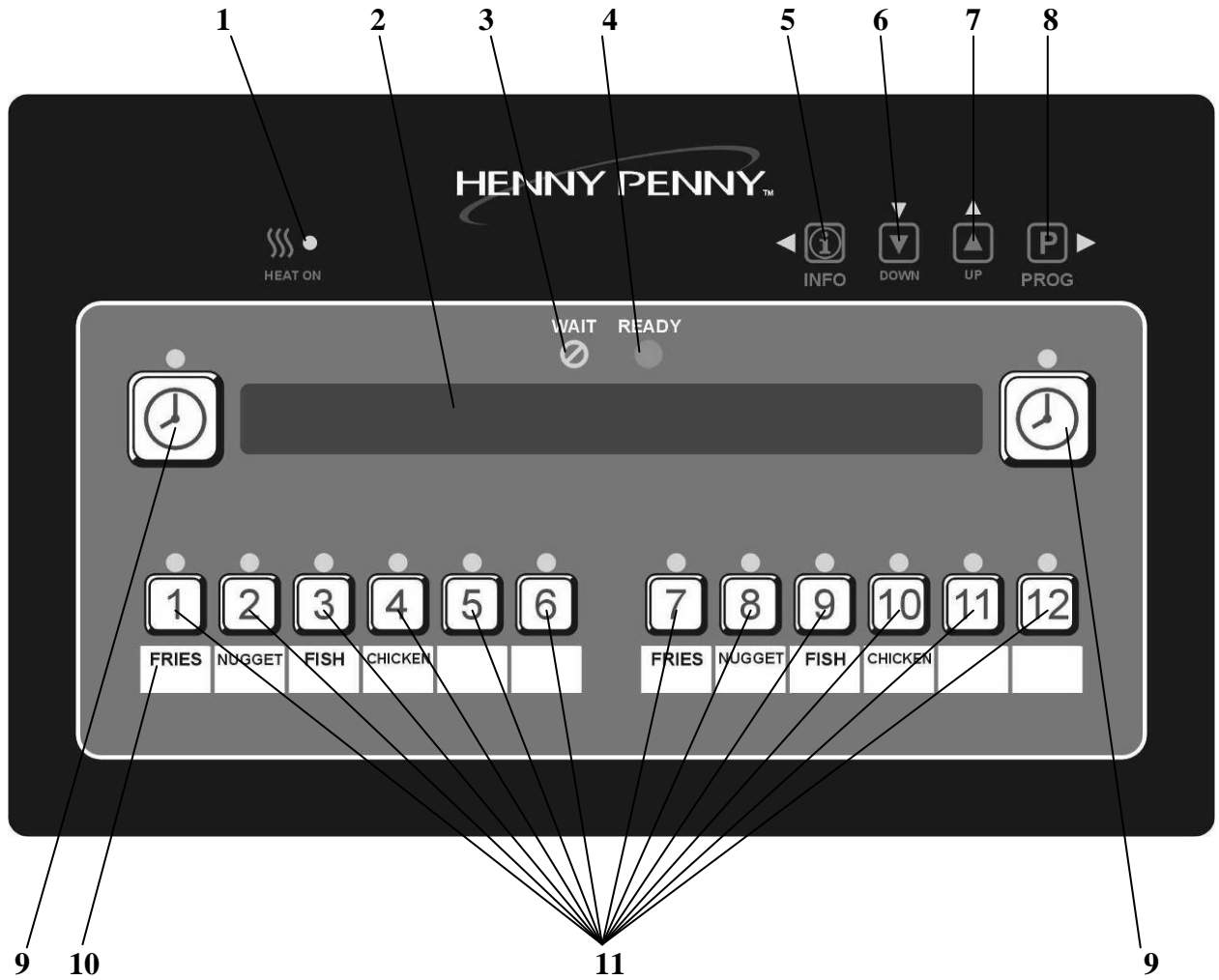

Figure 3-2

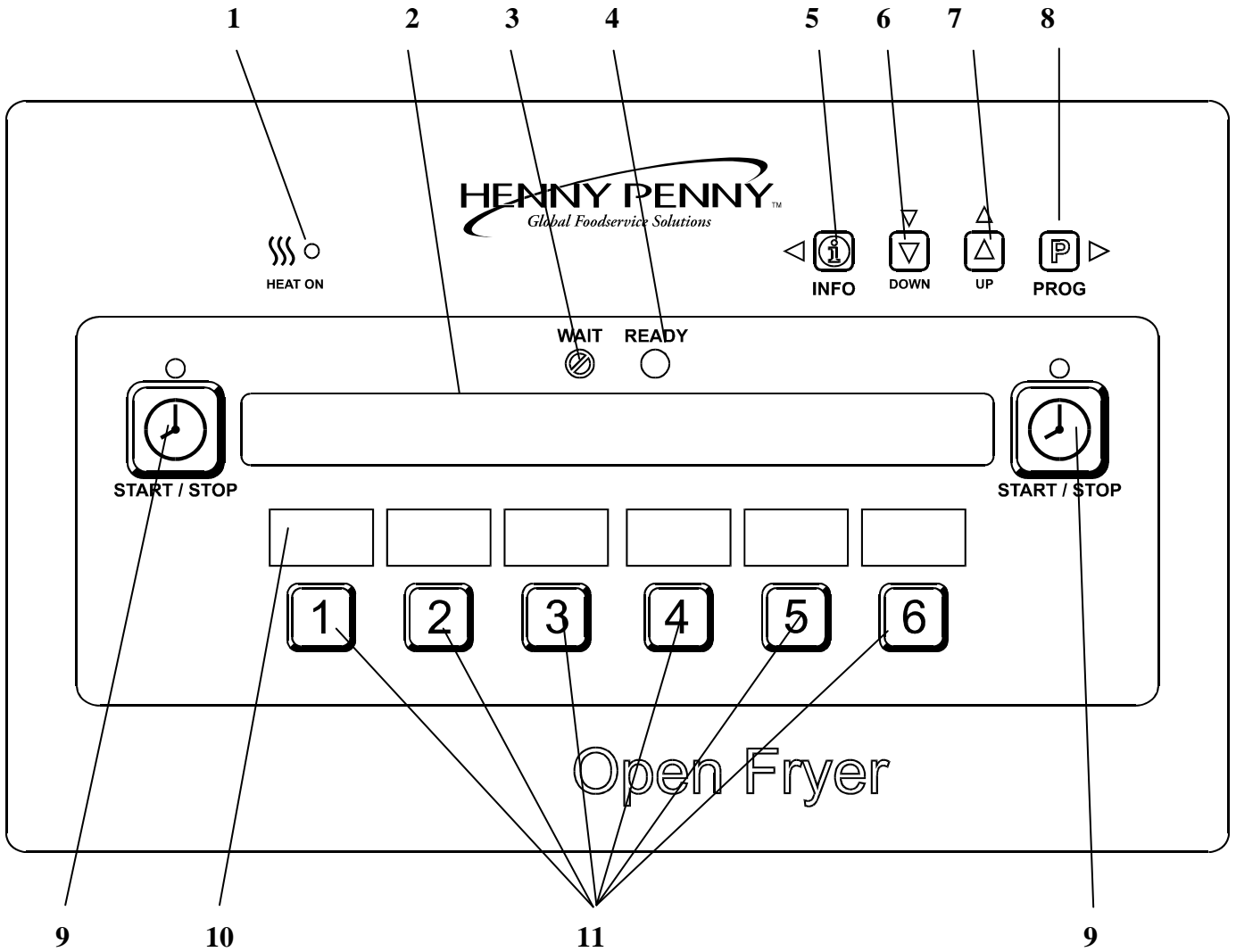



















Figure 3-3









3-3. CLOCK SET

NOTICE

Upon initial start-up or PC board replacement, if “CLOCK SET” automatically appears in the display, skip steps 1, 2 and 3.

1. Press and hold  for 5 seconds until “LEVEL 2” shows in display.
2. Release , then press  twice. “CLOCK SET” then “ENTER CODE” shows in display.
3. Press   .
4. Display shows “CS-1” then “SET” then “MONTH”, with the month flashing.
5. Press   to change the month.
6. Press . Display shows “CS-2” then “SET” then “DATE”, with the date flashing.
7. Press   to change the date.
8. Press . Display shows “CS-3” then “SET” then “YEAR”, with the year flashing.
9. Press   to change the year.
10. Press . Display shows “CS-4” then “SET” then “HOUR”, with the hour and “AM” or “PM” flashing.
11. Press   to change the hour and AM/PM setting.
12. Press . Display shows “CS-5” then “SET” then “MINUTE”, with the minutes flashing.

3-3. CLOCK SET
(Continued)

13. Press   to change the minutes.
DOWN UP
14. Press  . Display shows “CS-6” then “CLOCK
PROG
MODE”, along with “1.AM/PM”.
15. “1.AM/PM” is 12 hour time, “2.24-HR” is 24 hour time. Press   to change.
DOWN UP
16. Press  . Display shows “CS-7” then “DAYLIGHT
PROG
SAVINGS ADJ”, along with “2.US”.
17. Press   to change to the following:
DOWN UP
 - a. “1.OFF” = No automatic adjustments for Daylight Savings Time.
 - b. “2.US” = Automatically applies United States Daylight Saving Time adjustment. For 2006 & earlier: DST starts on first Sunday in April, and ends on last Sunday in October. For 2007 & later: DST starts on second Sunday in March, ends on first Sunday in November.
 - c. “3.EURO” = Automatically applies European (CE) Daylight Savings Time adjustment. DST activated on the last Sunday in March. DST de-activated on the last Sunday in October.
 - d. “FSA” = Old “First Sunday in April” schedule, in case US ever goes back to old schedule. DST starts on the first Sunday in April. DST ends on the last Sunday in October.
18. Clock Set is now complete. Press and hold  to exit.
PROG

**3-4. FILLING OR
ADDING SHORTENING**

CAUTION

The shortening level must always be above the heating elements when the fryer is heating and at the frypot level indicators on the rear of the frypot. Failure to follow these instructions could result in a fire and/or damage to the fryer.

When using solid shortening, it is recommended to melt the shortening on an outside heating source before placing it in the frypots. The heating elements or burner tubes must be completely submerged in shortening. Fire or damage to the frypot could result.

1. It is recommended that a high quality frying shortening be used in the open fryer. Some low grade shortenings have a high moisture content and will cause foaming and boiling over.



Wear gloves to avoid severe burns when pouring hot shortening into frypot. Shortening and all metal parts that are in contact with the shortening are extremely hot, and take care to avoid splashing.

2. The full frypots require 65 lbs. (29.5 kg) of shortening, while the split frypot requires 25 lbs. (11.3 kg.). All gas frypots, and some electric frypots, have 2 level indicator lines inscribed on the rear wall of the frypot which shows when the heated shortening is at the proper level. Some electric models only have 1 level indicator line on the frypots.
3. Cold shortening should be filled to the lower indicator when the frypot has 2 indicator lines, and a ½ inch (12.7 mm) below a single indicator line.

**3-5. C1000 OPERATIONS
AND PROCEDURES**

The Computron 1000 controls are available on both split frypot and full frypot fryers. The following is a brief description of the operating procedures for fryers with these controls.

1. Be sure the drain valve is in the closed position.
2. Place basket support inside of frypot.
3. Make sure frypot is filled with shortening to the proper level.
4. Display shows “OFF” until power switch is turned to the ON position. Display now shows the cook time and the unit automatically goes into the Melt Cycle until the shortening temperature reaches 250°F (121°C). The control then automatically exits the Melt Cycle.

NOTICE

The OFG-320 series open fryer has several safety devices which shuts-down the gas supply when they are activated. The above procedures should be followed to restart the open fryer and if the shut down is repeated, a qualified technician should be notified.

The Melt Cycle may be bypassed, if desired, by pressing and holding  for 3 seconds.

CAUTION

Do not bypass the Melt Cycle unless enough shortening on gas fryers and elements on electric fryers. If Melt Cycle is bypassed before all burner tubes or elements are covered, excessive smoking of the shortening, or a fire will result.

5. Once out of the Melt Cycle, the shortening is heated until  lights and the cook time is displayed.



Thoroughly stir shortening to stabilize the temperature throughout the frypots.

6. Before loading product into the baskets, lower baskets into the hot shortening to keep the product from sticking to the baskets.
7. Once the shortening temperature has stabilized at the setpoint temperature, lower the basket with product into the frypot.

**3-5. C1000 OPERATIONS
AND PROCEDURES
(Continued)**



Do not overload, or place product with extreme moisture content into the basket. 12.5 lbs. (5.7 kg) is the maximum amount of product per frypot (6.25 lbs. (2.8 kg) maximum for the split frypot fryers). Failure to follow these directions can result in shortening overflowing the frypot. Serious burns or damage to the unit could result.

9. If the right basket was dropped into the shortening, then press the right  .
If the left basket was dropped, then press the left  .
10. The timer on the appropriate side (right or left) starts counting down.



NOTICE

The timing operation of the two sides of the control is entirely independent of each other. One may be set, started, or stopped without affecting the other.



11. At the end of the Cook Cycle a tone will sound and the display flashes “DONE”. Press  button and lift the basket from the shortening.

**3-6. C1000 PROGRAMMING
INSTRUCTIONS**



Timer Programming

1. Anytime the cook time is displayed, press   under the appropriate display to change the cook time.

Set-Point Temperature Programming

1. Press **[P]** once to view the actual shortening temperature and press **[P]** again to view the set-point temperature.
2. While the set-point temperature is in the display, press   to change the set-point temperature.





















NOTICE

If “LOCK” shows in display when pressing   , the controls are locked and must be unlocked before changing the time or set-point temperature. See C1000 Special Programming Section.

3-7. C1000 SPECIAL PROGRAMMING

Special Programming is used to set the items below:

- Fahrenheit or Celsius
- Initialize System
- Lock or Unlock Controls
- Fryer Type – Open or Pressure
- Heat Source – Electric; Gas w/standing pilot; Gas w/electronic ignition; Gas-Induced Draft
- Vat Type - Split or Full Vat (frypot)
- Oil Type - Solid or Liquid

1. To enter Special Programming, turn off power switch (either side). Press and hold  and turn the power switch back on.
2. “SPEC” “PROG” followed by, “DEG” “°F” or “°C”. Use   to choose “°F” or “°C”.
3. Press  and “INIT” shows in the display.
Press and hold the right  and display shows “In-3”, “In-2”, “In-1” followed by “Init Sys” “DONE DONE”. The controls now are reset to factory parameters, the time set to 0:00 and temperature 190°F or 88°C.
4. Press  and “LOCK” or “UNLOCK” shows in the displays. Use   to choose “LOCK” or “UNLOCK”.
5. Press  and “FRYR” shows in left display and the right display should show “OPEN”. Use   to change from “PRES” to “OPEN” if needed.
6. Press  and “FRYR” shows in the display. Use   to change the fryer type: “ELEC” for electric models; “GAS” for units with standing pilot; SSI for units with solid state ignition; IDG for units with induced draft gas burners.
7. Press  and “VAT” shows in the display. Use   to choose “SPLIT” or FULL” vat (frypot) type.
8. Press  and “MELT” and “Solid” or “LIQD” shows in the displays. Use   to choose “Solid”, if using solid shortening, or “LIQD”, if using liquid shortening.
9. Press and hold  to exit Special Programming at any time.

**3-8. BASIC OPERATIONS
AND PROCEDURES
(6 Product Controls)**

The Henny Penny Open Fryer has electronic controls for each frypot. The following is brief description of the operating procedures for controls with 6 product buttons.

1. Be sure the drain valve is in the closed position.
2. Place basket support inside of frypot.
3. Make sure frypot is filled with shortening to the proper level
4. Move power switch to the ON position. Unit automatically goes into the Melt Cycle until the shortening temperature reaches 230°F (110°C). The control then automatically exits the Melt Cycle.

NOTICE

The OFG-320 series open fryer has several safety devices which shuts-down the gas supply when they are activated. The above procedures should be followed to restart the open fryer and if the shut down is repeated, a qualified technician should be notified.

The Melt Cycle may be bypassed, if desired, by pressing a product button and holding it for five seconds.

CAUTION

Do not bypass the Melt Cycle unless enough shortening has melted to completely cover all of the burner tubes on gas fryers and elements on electric fryers. If Melt Cycle is bypassed before all burner tubes or elements are covered, excessive smoking of the shortening, or a fire will result.

5. Once out of the Melt Cycle, the WAIT LED flashes until the setpoint temperature has been reached. Then the READY LED lights, and the selected product displays on the left and right side of the display.

NOTICE

The timing operation of the two sides of the control is entirely independent. They may be set, started, or stopped without affecting each other.

If the Energy Save Mode is activated for gas fryers, the pilot light goes out and the blower turns off, if the fryer is idle for 2 minutes with the READY LED lit. Starting a Cook Cycle exits the Energy Save Mode, or if the shortening temperature drops to where the READY LED goes out, the fryer resumes normal heat-up mode until the READY LED comes back on. (See SP-19).

**3-8. BASIC OPERATIONS
AND PROCEDURES**
(6 Product Controls)
(Continued)

6. Thoroughly stir shortening to stabilize the temperature throughout the frypots.
7. Before loading product into the baskets, lower baskets into the hot shortening to keep the product from sticking to the baskets.
8. Once the shortening temperature has stabilized at the setpoint temperature, the operator can then lower the basket with product into the frypot.



Do not overload, or place product with extreme moisture content into the basket. 12.5 lbs. (5.7 kg) is the maximum amount of product per frypot (15.0 lbs. (6.8 kg) maximum for auto-lift open fryers). Failure to follow these directions can result in shortening overflowing the frypot. Serious burns or damage to the unit could result.

9. If the right basket was dropped into the shortening, then the right START/STOP button should be pressed. If the left basket was dropped, then the left START/STOP button should be pressed.
10. Once the START/STOP button has been pressed, the timer on the appropriate side (right or left) will start counting down.
11. At the end of the Cook Cycle a tone will sound and the display will flash “DONE”. Press the START/STOP button and lift the basket from the shortening.
12. The display will show which product it is ready to time down. If a hold time was programmed, the controller automatically starts the hold timer. The display alternately shows the product selected and the quality time remaining in minutes. If a different product is selected during the Hold Cycle, the display only shows the product selected. To view the hold time remaining, push the INFO button.
13. At the end of the Hold Mode, a tone will sound and the display will flash QUALITY and the product it was timing. Press and release the START/STOP button. The display shows the product it is ready to start timing for frying.

3-9. BASIC OPERATIONS
AND PROCEDURES
(12 Product Controls/Auto-lift)

Henny Penny Open Fryer models OFE/OFG are available with 12 product button controls. Also, models OEA/OGA are available with 12 button controls, equipped with auto-lift features. The auto-lift controls, allow the baskets to be automatically lowered into the shortening, at the beginning of the cook cycle, and raised from the shortening at the end of the cycle.

1. Be sure the drain valve is in the closed position.
2. Fill the frypot with shortening.
3. Move POWER switch to the ON position. Unit automatically goes into the Melt Cycle. When the temperature reaches 250°F (121°C), the control exits the Melt Cycle and heats the shortening until the temperature setting is reached.

NOTICE

The OFG-320 series open fryer has several safety devices which shuts down the gas supply when they are activated. The above procedures should be followed to restart the fryer and if the shut down is repeated, a qualified technician should be notified.

The Melt Cycle may be bypassed if desired, by pressing a product button and holding it for five seconds.

CAUTION

Do not bypass the Melt Cycle unless enough shortening on gas fryers and elements on electric fryers. If Melt Cycle is bypassed before all burner tubes or elements are covered, excessive smoking of the shortening, or a fire will result.

4. Once out of the Melt Cycle, the WAIT LED flashes until the setpoint temperature has been reached. Then the READY LED illuminates.

NOTICE

If the Energy Save Mode is activated for gas fryers, the pilot light goes out and the blower turns off, if the fryer is idle for 2 minutes with the READY LED lit. Starting shortening temperature drops to where the READY LED goes out, the fryer resumes normal heat-up mode until the READY LED comes back on. (See SP-19).

**3-9. BASIC OPERATIONS
AND PROCEDURES
(12 Product Controls/Auto-Lift)
(Continued)**

NOTICE

The timing operation of the two sides of the control can be programmed entirely independent from each other for 2 half baskets, or as one timer for a single full sized basket which will set on both lifts. The default setting from the factory is for two half sized baskets. To change to a single full size basket setting, push and hold the #1 product button while turning on the POWER switch. To change back to the two basket mode, push and hold the #2 product button while turning on the POWER switch.

5. Thoroughly stir shortening to stabilize the temperature throughout the frypots.
6. Before loading product into the baskets, lower baskets into the hot shortening to keep the product from sticking to the baskets.
7. Once the shortening temperature has stabilized at the setpoint temperature, the operator may now place the baskets into the shortening (or for auto-lift open fryers, lift basket onto the hangers). Place product into the basket.



Do not overload, or place product with extreme moisture content into the basket. 12.5 lbs. (5.7 kg) is the maximum amount of product per frypot (15.0 lbs. (6.8 kg) maximum for auto-lift open fryers). Failure to follow these directions can result in shortening overflowing the frypot. Serious burns or damage to the frypot could result.

8. If the right basket is to be lowered into the shortening, then one of the right product buttons should be pressed. If the left basket is to be lowered, then one of the left product buttons should be pressed.
9. The timer on the appropriate side will start counting down. (On auto-lift open fryers, the basket will automatically lower into the shortening.)

**3-9. BASIC OPERATIONS
AND PROCEDURES
(12 Product Controls/Auto-Lift)
(Continued)**

10. At the end of the Cook Cycle, a tone sounds and the display shows “DONE”. Lift the basket from the shortening. (On auto-lift open fryers, the basket automatically rises out of the shortening.) To stop the “DONE” beeper, either press the timer button, or the product button.

NOTICE

A different product can be selected during the first minute of cooking.

11. The display will show which product it is ready to time down. If a hold time was programmed, the controller will automatically start the hold timer. The display will alternately show the product selected and the hold time remaining in minutes. If a different product is selected during the Hold Cycle, the display will only show the product selected.
12. At the end of the Hold Cycle, a tone sounds and the display flashes “QUALITY”, and the product it was timing. Press and release the TIMER button.

NOTICE

In the Cook Mode, when “FILTER SUGGESTED” shows in the display, the operator has the option to filter at this time, or to continue cooking. But, if the operator continues cooking, a filter lockout occurs within the next Cook Cycle, or two.

When “FILTER LOCKOUT”, then “YOU *MUST* FILTER NOW.....” shows in the display, the PROG button is the only button that will function, until the unit is filtered.

3-10. CARE OF SHORTENING



FOLLOW THE INSTRUCTIONS BELOW TO AVOID SHORTENING OVERFLOWING THE FRYPOT, WHICH COULD RESULT IN SERIOUS BURNS, PERSONAL INJURY, FIRE, AND/OR PROPERTY DAMAGE.

1. Maintain the shortening at the proper cooking level. Add fresh shortening as needed.

3-10. CARE OF SHORTENING
(Continued)

2. To protect and get the maximum life out of the shortening, lower the temperature to 275° F (135° C) or lower when the fryer is not in immediate use. Deteriorated shortening smokes badly, even at lower temperatures.
3. Taste the cold shortening daily for signs of bad flavor. Discard any shortening which has a bad flavor or shows signs of excessive foaming or boiling. Keep the frypot clean.



WITH PROLONGED USE, THE FLASHPOINT OF SHORTENING IS REDUCED. DISCARD SHORTENING IF IT SHOWS SIGNS OF EXCESSIVE SMOKING OR FOAMING. SERIOUS BURNS, PERSONAL INJURY, FIRE, AND/OR PROPERTY DAMAGE COULD RESULT.

3-11. FILTERING OF SHORTENING

1. Turn the main switch to the OFF position. Remove and clean the fry basket in soap and water. Rinse thoroughly.



Best results are obtained when shortening is filtered at the normal frying temperature.

2. Use a metal spatula to remove any build up from the sides of the frypot. Do not scrape burner tubes on the gas models, or heating elements on electric models.



Scraping the electric fryer elements, or burner tubes of the gas frypot, produces scratches in these surfaces causing breading to stick and burn.



The filter drain pan must be as far back under fryer as it will go and the cover in place. Be sure the hole in the cover lines up with the drain before opening the drain. Failure to follow these instructions causes splashing of shortening and could result in personal injury.

Surfaces of fryer and baskets will be hot. Use care when filtering to avoid getting burned.

**3-11. FILTERING
OF SHORTENING
(Continued)**

3. Open door(s) under unit, and slowly turn drain valve handle a half turn. Leave for a few minutes, then slowly, fully open drain valve. This prevents much splashing of the hot shortening as it drains.
4. As the shortening drains from the frypot, use brushes to clean the sides of the frypot and the burner tubes or heating elements. If the drain fills with breading, use straight white brush to push excess breading into the filter drain pan.
5. When all of the shortening has drained, scrape or brush the sides and the bottom of the frypot.

6. Rinse the frypot as follows:
Standard 322, 323, & 324 Open fryers
 - a. Close the drain valve.
 - b. Position return line over empty frypot.
 - c. Move the pump switch to the pump position.
 - d. Fill the frypot 1/3 full, then turn off pump.
 - e. Wash down and scrub the sides of the frypot with the brushes.
 - f. After the sides and bottom are cleaned, open the drain valve.

321 Open fryers-After April, 2002

- a. Close the drain valve. Figure 3-3.
- b. Open the filter valve. Figure 3-3.
- c. Move the pump switch to the pump position.
- d. Fill the frypot 1/3 full, then turn off pump.
- e. Wash down and scrub the sides of the frypot with the brushes.
- f. After the sides and bottom are cleaned, open the drain valve.

DRAIN VALVE HANDLE FILTER VALVE HANDLE

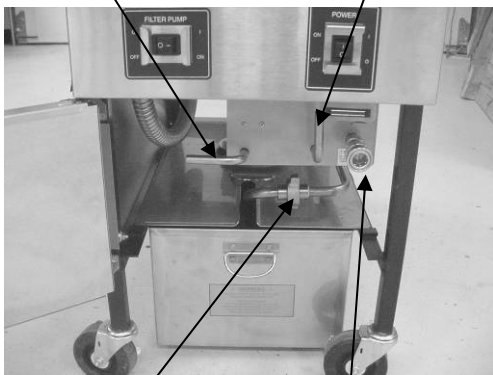

FILTER UNION FEMALE QUICK-DISCONNECT

Figure 3-3



IF THERE ARE AIR BUBBLES COMING UP IN THE SHORTENING BEFORE ALL SHORTENING IS PUMPED UP, IT'S POSSIBLE THAT THE FILTER CONNECTION AT THE UNION ON THE FILTER TUBE IS NOT TIGHTENED PROPERLY. IF SO, TURN OFF THE PUMP AND WEAR PROTECTIVE GLOVES OR CLOTH WHEN TIGHTENING THE UNION. THIS UNION WILL BE HOT. SEVERE BURNS COULD RESULT.

**3-11. FILTERING
OF SHORTENING
(Continued)**



Figure 3-4

With Optional Filter Rinse Hose

- Open the door and pull the collar back on the female quick-disconnect. Attach the male quick disconnect on the filter rinse hose, onto the female fitting. Figure 3-3.
- Point the hose nozzle down into the frypot, close the filter valve, and move the PUMP switch to the PUMP position. Hold nozzle carefully to avoid excessive splashing. Figure 3-4.



Use caution to prevent burns from splashing hot shortening.

- Rinse the frypot interior, especially hard to clean areas like the frypot bottom and heating elements.
- After sufficient rinsing, close the drain valve.
- Turn the PUMP switch to the OFF position.



ONLY CONNECT AND DISCONNECT THE FILTER RINSE HOSE WHEN THE PUMP SWITCH IS IN THE OFF POSITION. FAILURE TO DO THIS WILL RESULT IN SEVERE BURNS FROM HOT SHORTENING SPRAYING FROM THE FITTINGS. USE A DRY CLOTH OR PROTECTIVE GLOVE TO AVOID BURNS.

- Detach hose, and raise the fitting end of the hose high for a minute to allow remaining shortening in the hose to drain back into the frypot.

FILTER HANDLE



Figure 3-5

Autolift Open fryers

- Close the drain valve.
- Turn filter handle to the on position. Figure 3-5.
- Fill the frypot 1/3 full.
- Turn filter handle to the OFF position.



Use care when reaching across a frypot of hot shortening. Severe burns could result.

3-11. FILTERING
OF SHORTENING
(Continued)

- e. Wash down and scrub the sides of the frypot with the brushes.
- f. After the sides and bottom are cleaned, open the drain valve.



On 322, 323 and 324 open fryers, if shortening flow is slow from faucet, use cloth or protective gloves to tighten the filter union. This union will be hot. Severe burns could result.

7. Pump all of the shortening out of the filter drain pan and back into the frypot.
8. When the pump is pumping air only, move the pump switch from PUMP to OFF, or on auto-lift open fryers, turn filter handle to OFF.
321 Open fryers – When the pump is pumping air only, the shortening in the frypot appears to be boiling. Close the filter valve first, and then move the pump switch to the OFF position. This keeps the filter pump and lines from filling up with shortening.
9. Check the level of the shortening in the frypot. Add fresh shortening if necessary, until it reaches the top level indicator line on the rear wall of the frypot.



About 10 to 12 filterings can be made with one filter paper envelope, depending on:

- the quantity and type of product fried and filtered
 - the type of breading used
 - the amount of crumbs left inside the filter drain pan. When the filter screen assembly and filter paper become clogged, and the pumping flow slows, clean the filter screen assembly and change the filter envelope.
10. To continue cooking, move the main POWER switch to the ON position, and shortening reheats.

3-12. FILTER PUMP PROBLEM PREVENTION

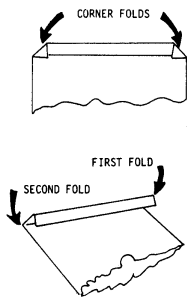

Figure 3-6

To help prevent filter pump problems:

1. Properly install paper envelope over the filter screens. Fold the open end of the envelope, and clamp with retaining clips so that crumbs cannot enter. Figure 3-6.
2. Pump shortening, until no shortening is coming from the nozzle.

3-13. FILTER PUMP MOTOR PROTECTOR – MANUAL RESET



Figure 3-7

In the event it overheats, the filter pump motor is equipped with a manual reset button located on the rear of the motor. After waiting 5 minutes to allow the motor to cool, press the reset button. It takes some effort to reset the motor. A screwdriver can be used to help press reset button. Figure 3-7.

Servicing of the filter pump is done at the rear of the unit. If service is required, disconnect the open fryer from the electrical and/or gas power source, and pull the open fryer out from the wall to gain access to rear.



To prevent burns caused by splashing shortening, turn the unit's filter PUMP switch to the OFF position before resetting the filter pump motor's manual reset protection device.

3-14. CHANGING THE FILTER ENVELOPE

The filter envelope should be changed after 10-12 filterings or whenever it becomes clogged with crumbs. Proceed as follows:



The filter union could be hot. Wear protective glove or cloth, or severe burns could result.

Use care to prevent burns caused by splashing of hot shortening.

1. Move the main POWER switch to the OFF position.
2. Disconnect the filter union and remove the filter drain pan from beneath the frypot.

**3-14. CHANGING THE FILTER
ENVELOPE**
(Continued)

3. Remove cover from filter drain pan and lift the filter screen assembly from the drain pan.
4. Wipe the shortening and crumbs from the filter drain pan. Clean the drain pan with soap and water. Thoroughly rinse with hot water.
5. Unthread the standpipe from the filter screen assembly.
6. Remove the crumb catcher and clean with soap and water. Rinse thoroughly with hot water.
7. Remove the filter clips and discard the filter envelope.
8. Clean the top and bottom filter screen with soap and water. Rinse thoroughly with hot water.

NOTICE

Be sure that the filter screens, crumb catcher, filter clips and the standpipe are thoroughly dry before assembly of the filter envelope or water will dissolve the filter paper.

9. Assemble the top filter screen to the bottom filter screen.
10. Slide the screen into a clean filter envelope.
11. Fold the corners in and then double fold the open end.
12. Clamp the envelope in place with the two filter retaining clips.
13. Replace the crumb catcher screen on top of the filter paper. Screw on the standpipe assembly.
14. Place complete filter screen assembly back into filter drain pan, replace cover, and slide pan back into place beneath the open fryer.
15. Connect the filter union by hand. Do not use a wrench to tighten.
16. The open fryer is now ready to operate.

3-15. CLEANING
THE FRYPOT

After the initial installation of the open fryer, as well as before every change of shortening, the frypot should be thoroughly cleaned as follows:

1. Turn the main POWER switch off.



The filter drain pan must be as far back under fryer as it will go, and the cover in place. Be sure the hole in the cover lines up with the drain before opening the drain. Failure to follow these instructions causes splashing of shortening and could result in personal injury.

Moving the fryer or filter drain pan while containing hot shortening is not recommended. Hot shortening can splash out and severe burns could result.

Always wear chemical splash goggles or face shield and protective rubber gloves when cleaning the frypot as the cleaning solution is high in alkaline. Avoid splashing or other contact of the solution with your eyes or skins. Severe burns may result. Carefully read the instructions on the cleaner. If the solution comes in contact with your eyes rinse thoroughly with cool water and see a physician immediately.



CHEMICAL
SPLASH
GOGGLES



CHEMICAL
RESISTANT
GLOVES

2. If hot shortening is present in the frypot, it must be drained by slowly opening the drain valve handle one half turn. Leave for a few minutes, then slowly open the valve to full open position.
3. Close the drain valve. Discard the shortening using the shortening shuttle.
4. Remove the filter screen assembly from the filter drain pan.



The filter union could be hot. Wear protective glove or cloth, or severe burns could result.

5. Fill the frypot to the level indicator with hot water. Add 4 ozs. (0.12 liters) of open fryer cleaner to the water and mix thoroughly. The fry basket can be placed inside the frypot for cleaning.

3-15. CLEANING
THE FRYPOT
(Continued)

6. Use the Clean-Out Mode (see section 3-13), or turn the main POWER switch to the ON position and set temperature to 195° F (90.5° C).
7. When the solution reaches 195° F (90.5° C), turn the main POWER switch to the OFF position.
8. Let the cleaning solutions stand for 15 to 20 minutes with the power off.
9. Using the open fryer brush (never use steel wool), scrub the inside of the frypot.

CAUTION

If the cleaning solution in the frypot starts to foam and boil over, immediately turn the power switch to OFF or damage to components could result.

Do not use steel wool, other abrasive cleaners or cleaners/sanitizers containing chlorine, bromine, iodine or ammonia chemicals, as these will deteriorate the stainless steel material and shorten the life of the unit.

Do not use a water jet (pressure sprayer) to clean the unit, or component damage could result.

10. After cleaning, open the drain valve and drain cleaning solution from the frypot into the filter drain pan and discard.
11. Replace the empty filter drain pan, close the drain valve, and refill the frypot with plain hot water to the proper level.
12. Add approximately 8 ozs. (0.24 liters) of distilled vinegar. Use the Clean-Out Mode (see section 3-13), or bring the solution back up to 195° F (90.5° C).
13. Using a clean brush, scrub the interior of the frypot. This will neutralize the alkaline left by the cleaning compound.
14. Drain the vinegar rinse water and discard.
15. Rinse down the frypot using clean, hot water.
16. Thoroughly dry the filter drain pan and the frypot interior.

NOTICE

Make sure the inside of the frypot, the drain valve opening, and all the parts that will come in contact with new shortening are as dry as possible.

3-15. CLEANING
THE FRYPOT
(Continued)

17. Replace the clean filter screen assembly in the drain pan, replace cover, and install filter drain pan under open fryer.
18. Refill the frypot with fresh shortening.

NOTICE

Henny Penny has the following cleaners available:

Foaming Degreaser - Part no. 12226

PHT Liquid Cleaner - Part no. 12135

PHT Dry Powder Cleaner - Part no. 12101



See your local distributor for details.

3-16. CLEAN-OUT MODE
(6 & 12 Product Controls Only)

When heating the cleaning solution and vinegar solutions, turn the POWER switch to the ON position. When the fryer starts the Melt Cycle, press and hold  then

“CLEAN-OUT ?”, “1=YES 2=NO” shows in display.

Press  to start Clean-Out Mode. The fryer displays

“*CLEAN-OUT MODE*” and heats up to a preprogrammed temperature, up to 195°F (91°C), then automatically begins a preset timed countdown. Use the   buttons, if necessary, to adjust the temperature

and keep the cleaning solution from boiling over.

Once the timed countdown is complete and display shows “CLEANING DONE”, refer back to the Cleaning the Frypot procedures for more detailed instructions.

See Special Program Modes SP-20 and SP-21 to preset the temperature and time.

3-17. OPERATING INSTRUCTIONS
FOR OPTIONAL DIRECT-
CONNECT SHORTENING
SYSTEM



Figure 3-8



Figure 3-9



Figure 3-10

1. Connect the female quick disconnect, that is attached to the hose in the rear of the open fryer, to the correct male quick disconnect at the wall. Once attached, the hose can remain connected unless the open fryer is moved. Figures 3-8 & 3-9.



The hose is to be attached to shortening return line only for the system to work properly.

2. Open the drain valve and drop the shortening from the desired frypot, into the filter drain pan.
3. Pull diverter-handle towards you, in the back of the fryer, from FILTER to DISCARD. Figure 3-10.



This handle could be hot! Use protective gloves or cloth when turning diverter-handle, or burns could result.

4. Once all shortening is gone from frypot, turn the filter pump switch to the ON position. Shortening is now pumped from the filter drain pan.

**3-17. OPERATING INSTRUCTIONS
FOR OPTIONAL DIRECT-
CONNECT SHORTENING
SYSTEM (Continued)**



Figure 3-11

**3-18. LIGHTING AND
SHUTDOWN OF THE
BURNERS**

5. Once all the shortening is out of the filter drain pan, turn the filter pump switch to the OFF position.
6. Push diverter-handle, in the back of the fryer, from DISCARD to FILTER. Figure 3-11.
7. Frypot is now ready for fresh shortening.

To light burner:

1. Turn the power switch to the OFF position.
2. Rotate the gas control valve knob clockwise to the OFF position and wait at least 5 minutes before continuing to the next step.
3. Rotate gas control valve counterclockwise to the ON position.
4. Place the power switch to the ON position.
5. The burner will light and operate in a Melt Cycle until the shortening reaches a preset temperature.
6. Press the desired product button after the READY LED illuminates.

To shutdown burner:

1. Turn the power switch to the OFF position.
2. Rotate gas control valve knob to the OFF position.

This fryer is equipped with a grounded (earthed) cord and plug for your protection against shock, and should be plugged into a 3 prong grounded (earthed) receptacle. Do not cut or remove grounding prong.

**3-19. HIGH TEMPERATURE
LIMIT CONTROL**



Figure 3-12

This high temperature control is a safety, manual reset control, which senses the temperature of the shortening. If the shortening temperature exceeds 425°F (218°C), this switch opens and shuts off the heat to the frypot. When the temperature of the shortening drops to a safe operation limit, the control must be manually reset by pressing the red reset button. The red reset button is located under the control panel, in the front of the fryer. Figure 3-12. This allows heat to be supplied to the frypot once again.

3-20. REGULAR MAINTENANCE

As in all food service equipment, the Henny Penny Open Fryer does require care and proper maintenance. The table below provides a summary of scheduled maintenance procedures to be performed by the operator.

Procedure	Frequency
Filtering of shortening	Daily (3-4 loads) See Filtering of Shortening section
Changing of shortening	When shortening smokes, foams up violently, or tastes bad
Changing the filter envelope	After 10-12 filterings, or when envelope is clogged with crumbs. See Changing the Filter Envelope section
Cleaning the frypot	Every change of shortening. See Cleaning the Frypot section



If moving fryer to perform preventive maintenance:

- **Gas supply should be turned off to avoid fire or explosion.**
- **Electrical supply should be unplugged or wall circuit breaker turned off to avoid electrical shock.**

SECTION 4. PROGRAMMING – 6 & 12 PRODUCT CONTROLS

4-1. INTRODUCTION

The controls are preset from the factory, but desired functions can be programmed in the field. Press and hold the PROG button for one second to access the Product Programming Mode. By continuing to hold the PROG button for five seconds, you may access Level 2 programming.

4-2. PRODUCT PROGRAM MODE

This mode allows the operator to change and set various parameters for each product.

1. Press and hold the PROG button for one second. “PROG” shows in the display.
2. After 5 seconds, “ENTER CODE” scrolls through the display.
3. Enter code 1,2,3. “SELECT PROG PRODUCT” now scrolls across the display.
4. Press and release the desired product button (1 thru 12, - 12 timer controls or, 1 thru 6, - 6 timer controls).
5. Press and release the PROG button. The present name of that product will show in the display. Ex., “NAME FRIES”.
Change Product Names
 - a. Press and release the UP or DOWN arrows and the first letter, or digit, starts flashing.
 - b. Press and release the UP or DOWN arrows to change the flashing letter.
 - c. To continue to the next letter, press the PROG button. Then press the UP or DOWN buttons to change this letter.
6. Press and release the PROG button and “COOK TIME” shows in the display along with the preset time in the right side of the display. Press the UP or DOWN buttons to change the time. The time will show in minutes and seconds. Press and hold the buttons, and the time will jump by 5 second increments to a maximum of 59:59.

**4-2. PRODUCT PROGRAM
MODE (Continued)**

7. Press and release the PROG button a second time and “TEMP” shows in the display, along with the preset temperature on the right side of the display. Press the UP or DOWN button to change the temperature. Press and hold the buttons and the temperature will jump by 5 degree increments to a maximum of 390°F (200°C), and a minimum of 200°F (100°C).
8. Press and release the PROG button a third time and “COOK ID” shows in the display along with the product ID. For example, FF would be the ID for french fries And NU would be the ID for nuggets. Press the UP and DOWN arrows to change the ID letters.
9. Press and release the PROG button a fourth time and “LOAD COMP” shows in the display along with the load compensation value on the right side of the display. Press and release the UP and DOWN arrows to change this value to a maximum of 20 and a minimum of 0.
10. Press and release the PROG button a fifth time and “LCOMP AVG” shows in the display along with the load compensation average temperature on the right side of the display. Press and release the UP and DOWN arrows to change this value to a maximum of 50 degrees below the setpoint temperature.
11. Press and release the PROG button a sixth time and “ALARM – 1 AT 0:00” shows in the display. Press and release the UP and DOWN arrows to set a time an alarm is to sound. Ex., If a cook cycle was set at 3 minutes, and an alarm was to go off after 30 seconds into the cook cycle, 2:30 would be set in the display at this time. When the timer counts down to 2:30 the alarm will sound.

NOTICE

Up to 4 alarms can be programmed. After the first one is set, the other alarms can be accessed by pressing the PROG button again.

**4-2. PRODUCT PROGRAM
MODE (Continued)**

NOTICE

On 12 button controls, additional prompts will show in the display. These will be “NONE”, “SHAKE”, “STIR”, “ADD”, or “PAUSE”. Use the UP and DOWN buttons to select the word to show in the display if an alarm is programmed. If PAUSE is selected, on auto-lift open fryers, the basket automatically rises out of the shortening and timer will stop the countdown. The TIMER button must be pressed to lower the basket back into the shortening and resume the timer.

12. Press and release the PROG button until “QUALITY TMR” shows in the display along with the preset holding time on the right side of the display. Press and release the UP and DOWN buttons to adjust the holding time.

NOTICE

To exit the Program Mode at any time, press and hold PROG button for 2 seconds.

Filter Cycle Mode (Optional)

For “2,MIXED”, or “3,GLOBAL” to appear in the Product Program Mode, the Filter Tracking must be enabled in the Special Program Mode. (See section 4-3.)

13. Press the PROG button.
2,MIXED
 - a. “FILTER AFTER” shows in the display, along with the preset number of cook cycles on the right side of the display.
 - b. Press and release the UP and DOWN buttons until the desired number of cook cycles between filters shows in the display. For example, if 4 is set for a product, each time that product is selected, it counts 1/4, or 25%. Then each time a product is selected, the percentages add up until 100%, or more is reached. Then the display shows “FILTER SUGGESTED”.**3,GLOBAL**
 - a. “FILTER INCL” shows in the display, along with “NO” or “YES”.
 - b. Press and release the UP and DOWN buttons to “YES” if that product is to be included in the filter count, or “NO” if is not.

4-3. SPECIAL PROGRAM MODE

The Special Program mode is used to set more detailed parameters listed below.

- SP-1** • Degrees Fahrenheit or Celsius
- SP-2** • Language: English, French, German, Spanish and Portuguese
- SP-3** • System Initialization (Factory Presets)
- SP-4** • Audio Volume
- SP-5** • Audio Tone
- SP-6** • Audio Effect
- SP-7** • Type of Shortening to be Melted - Liquid, Solid
- SP-8** • Idle Mode
- SP-9** • Filter Tracking
- SP-10** • Product Buttons
- SP-11** • Cooking Display
- SP-12** • Quality Timer Display
- SP-13** • Enable 2 Products per Button (6 Product Controls)
- SP-13** • Baskets - 1 or 2 (12 Product Controls Only)
- SP-14** • Active Quality Timers (6 Product Controls Only)
- SP-14** • Auto-lift Detection (12 Product Controls Only)
- SP-15** • Program code change
- SP-16** • Usage code change
- SP-17** • Change shortening - A-Cook Cycles
- SP-18** • Change shortening - B-Hours
- SP-19** • Energy Save Enabled? (Gas Fryers)
- SP-20** • Clean-out minutes
- SP-21** • Clean-out temperature

1. Press and hold the PROG button for 5 seconds until “L-2” and “LEVEL 2”, followed by, “SP PROG” and “ENTER CODE” show in the display.
2. Enter code 1,2,3, and “SP-1”, “TEMP”, “UNITS” show in the display.

NOTICE

If a bad code is entered, a tone sounds and “BAD CODE” shows on the display. Wait a few seconds, the controls revert back to the cook mode, and repeat the above steps.

To exit from the Special Program Mode at any time, press and hold the PROG button for 2 seconds.

3. Set the detailed parameters as follows:
Degrees Fahrenheit or Celsius (SP-1)
 - a. Follow steps 1 and 2 above.
 - b. The display will flash “SP-1” and “TEMP”, “UNITS”, along with °F or °C in the right side of the display. Press the UP or DOWN buttons to toggle from °F to °C, or vice versa.

**4-3. SPECIAL PROGRAM
MODE (Continued)**

Language (SP-2)

- a. Follow steps 1 and 2 above.
- b. Press and release the PROG button. “SP-2” and “LANGUAGE” flash on the display, along with the language type in the right side of the display (Ex., “1.ENGL”).
- c. To toggle to the desired language, press and release the UP and DOWN buttons.

System Initialization (SP-3)

This step will reset the cook programs to factory settings.

- a. Follow steps 1 and 2 above.
- b. Press and release the PROG button twice. “SP-3” and “DO SYSTEM INIT” flash in the display, along with “INIT” on the right side of the display.
- c. Press and hold the DOWN button. “INIT” shows on the display, a tone sounds, and “IN 3”, “IN 2”, “IN 1” flashes on the right side of the display. When “INIT” starts flashing on the left side of the display, release the DOWN button. When “DONE” shows on the display, the initialization is complete, and the controls now have factory preset parameters.

Audio Volume (SP-4)

The volume of the speaker can be adjusted.

- a. Follow steps 1 and 2 above.
- b. Press the PROG button 3 times. “SP-4” and “AUDIO VOLUME” flash in the display, along with the volume value on the right side of the display.
- c. Press the UP and DOWN buttons to adjust the volume of the speaker, 10 being the maximum value and 1 the minimum.

Audio Tone (SP-5)

The tone of the speaker can be adjusted.

- a. Follow steps 1 and 2 above.
- b. Press the PROG button 4 times. “SP-5” and “AUDIO TONE (HZ)” flash in the display, along with the tone value on the right side of the display.
- c. Press the UP and DOWN buttons to adjust the tone of the speaker, 2000 being the maximum, 50 being the minimum.

**4-3. SPECIAL PROGRAM
MODE (Continued)**

Audio Effect (SP-6)

This setting lets you add an audio effect- i.e. a pulsed or warble sound – to the beeps generated in the cook mode.

- a. Follow steps 1 and 2 above.
- b. Press the PROG button 5 times. “SP-6” and “AUDIO EFFECT” show in the display, along with the effect value in the right of the display.
- c. Press the UP and DOWN buttons to change the sound effect of the tone. The numbers correspond as follows:
 - “0” = Normal Tone
 - “1” = Fast-Pulsed Tone
 - “2” = Slow-Pulsed Tone
 - “3” = Warble Tone

Type of shortening to be melted - Liquid or Solid (SP-7)

The Melt Cycle can be set to the type of shortening being used.

- a. Follow steps 1 and 2 above.
- b. Press and release the PROG button 6 times. “SP-7” and “MELT CYCLE SELECT” flash in the display, along with “1=LIQ” or “2=SOLID” shows on the right side of the display.
- c. Press the UP or DOWN buttons to toggle from one type to another.

CAUTION

The type of shortening being used in the open fryer determines the amount of heat applied during the Melt Cycle. If the controls are set to the solid setting, less heat is applied to the shortening, than if the controls were set to the liquid option. Too much heat applied to solid shortening will cause excessive smoking, and could cause a fire. This setting should match the type of shortening being used at the time.

**4-3. SPECIAL PROGRAM
MODE (Continued)**



When using solid shortening, it is recommended to melt some of the shortening on an outside heating source before placing the shortening in the frypots. The heat exchange tubes must be completely surrounded by liquid shortening. Fire or damage to the frypot could result.

Idle Mode (SP-8)

An Idle Mode can be programmed to allow the shortening temperature to drop to a lower temperature when not in use. This will be a savings on the shortening and utilities.

- a. Follow steps 1 and 2 above.
- b. Press and release the PROG button 7 times.
“SP-8” and “IDLE MODE ENABLED?” flash in the display, along with “NO” or “YES” on the right side of the display.
- c. Press and release the UP or DOWN buttons to toggle from “NO” to “YES”, or vice versa.
- d. With “YES” in the display, the Idle Mode is enabled. Press and release the PROG button. “SP-8A” and “IDLE SET PT TEMP” show in the display, along with the preset temperature in the right side of the display.
- e. The setpoint, at which the temperature the shortening will stay idle at, can be changed at this time by pressing the UP or DOWN buttons.
- f. Press and release the PROG button. “SP-8B” and “AUTO-IDLE MINUTES” show in the display, along with the preset time on the right side of the display.
- g. Press the UP and DOWN buttons to set the minutes the open fryer stays idle before the auto-idle is enabled, “60” is the maximum, “OFF” the minimum. Ex., “30” in the display means, if product is not cooked in that particular frypot for 30 minutes, the control automatically cools the shortening down to the idle setpoint temperature, programmed above.
- h. To use product button number 6 (P6) as the idle button (P12 for 12 button controllers), press the PROG button. “SP8C” and “USE P6 FOR IDLE” (12 for 12 button controllers), show in the display, along with “NO” or “YES” on the right side of the display.

**4-3. SPECIAL PROGRAM
MODE (Continued)**

- i. Press the UP or DOWN buttons to toggle from “NO” to “YES”. If “YES” is in the display, then during a time of low volume, the operator can press the P6 button (or P12) to manually enter the Idle mode.

NOTICE

Programming the idle on auto-lift open fryers, disables the basket lift function of the P12 button.

Filter Tracking Enabled (SP-9)

The controls can be set to signal the operator when the shortening needs filtering. The filter tracking must be enabled to program the number of cook cycles between filtering procedures. (See Filter Cycles in Product Program section.)

- a. Follow steps 1 and 2 above.
- b. Press and release the PROG button until “SP-9” and “FILTER TRACKING ENABLED” flash on the display, along with “1,OFF” on the right side of the display.
- c. To enable the filter tracking, press either the UP or DOWN buttons to toggle the display from “1,OFF”, to “2,MIXED”, “3,GLOBAL”, or “4,SCHED”

NOTICE

The “MIXED” option allows the operator to set different amounts of Cook Cycles, between filters, for each product. If the operator wants to have one setting for all products, go to step g.

MIXED

- d. If “2,MIXED” is selected, press the PROG button and ”SP-9A” shows in the display followed by “SUGGEST FILTER AT ...” and a value between 75% and 100% on the right display. Press and release the UP and DOWN arrows to change this value.

**4-3. SPECIAL PROGRAM
MODE (Continued)**

- e. Press the PROG button and “SP-9B” shows in the display followed by SP-9B "LOCKOUT - HEAT OIL..." and a shortening temperature, when reached, allows the operator to filter. Example, "LOCKOUT - HEAT OIL... 300F" means the display shows "FILTER LOCKOUT" "WAIT", until 300F is reached, then display shows "FILTER LOCKOUT"/"YOU *MUST* FILTER NOW", and repeated high-low tones are activated. This prompts the user that it is now time to filter the shortening. Press and release the UP and DOWN arrows to change this value.
- f. Now, go back to the Product Program Mode, to the Filter Cycle, and program in the number of Cook Cycles between filtering.

GLOBAL

- g. If “3,GLOBAL” is selected, “SP-9A” shows in the display, and followed by “GLOBAL FILTER CYCLES”. The right side of the display will show a digit, 1 to 99. Press the UP or DOWN buttons to set the desired amount of Cook Cycles between filters.



When the unit is on, the number of global Cook Cycles remaining, before Filter Lockout occurs, shows in the center of the display. Ex., “----- 5x -----“.

- h. Now, go back to section 4-2 and enter the Program mode. Press the PROG until “FILTER INCL” shows in the display (step 13). Each product must be set to “YES” to be included in the filter tracking.

SCHEDULE

- i. If “4,SCHED” is selected, “SP-9A” shows in the display, and followed by “SCHEDULE”. Press the PROG button and up to 4 different times of day can be programmed, using the UP or DOWN buttons. EX:

SP-9A	“SCHEDULE”	F1:	10.00A
SP-9B	“SCHEDULE”	F2:	2.00P
SP-9C	“SCHEDULE”	F3:	8.00P
SP-9D	“SCHEDULE”	F4:	----

Unneeded times should be left at “- - -“, otherwise, “Filter Suggested” shows in the display, prompting the operator to start filtering.

4-3. SPECIAL PROGRAM
MODE (Continued)

NOTICE

Cooking is still permitted during the “suggested” phase. However, if lockout is enabled, and the fryer still has not been filtered after one hour, then the controller activates lockout mode and prompts “FILTER LOCKOUT – YOU *MUST* FILTER NOW”.

- j. Press the PROG button and “SP-9E” “SKIP IF LESS THAN...” shows in the display, followed by the number of loads between filters, ex: “LOAD 4”. In this example, if the suggested filter time occurs, before 4 loads have been cooked, then the filter operation is skipped. If more than 4 loads have been cooked, then “Filter Suggested” shows in the display. The numbers of loads can be set by using the Up and DOWN buttons.
- k. Press the PROG button and “SP-9F” shows in the display, followed by “LOCKOUT ENABLED?” Press the UP or DOWN buttons to choose “YES” or “NO”.
- m. Press the PROG button and “SP-9G” shows in the display followed by SP-9G “LOCKOUT - HEAT OIL...” and a shortening temperature, when reached, allows the operator to filter. Example, “LOCKOUT - HEAT OIL... 300F” means the display shows “FILTER LOCKOUT” “WAIT”, until 300F is reached, then display shows “FILTER LOCKOUT”/“YOU *MUST* FILTER NOW”, and repeated high-low tones are activated. This prompts the user that it is now time to filter the shortening. Press and release the UP and DOWN arrows to change

Product Buttons (SP-10)

This mode allows you to set up the way the product buttons are displayed in the Cook Cycle.

- a. Follow steps 1 and 2 above.
- b. Press and release the PROG button until “SP-10” and “PRODUCT BUTTONS” flash in the display.
- c. The first option, “1,COOK”, displays only the product button that is selected. When nothing is cooking, no product will be displayed. Products 1, 2, and 3 display on the left timer only, and products 4, 5, and 6 display on the right timer only. (1 to 6 on the left timer only, and 7 to 12, for 12 product controls)
The product button starts the cook cycle.
- d. The second option, “2,L+R” (“2,SELECT” for 12 product controls), automatically displays the product button selected in both timer displays. The timer buttons starts the cook cycle.

**4-3. SPECIAL PROGRAM
MODE (Continued)**

- e. **(6 Product Controls Only)** The third option, “3,L/R”, allows the operator to determine which timer the product selected goes to. If no timer switch is selected, then the product selected will automatically display in both timers. The timer buttons start the cook cycle.
- f. **(12 Product Controls Only)** The third option “3.MULTI”, allows multiple products to cook on each side, up to 12 cook cycles at the same time. The display shows the product with the least time remaining on each side. Pressing a product button for an already cooking product momentarily displays the time remaining for that product. Cook cycles are stopped by pressing the product button (press and hold to cancel before “*Done*”), or by pressing the Timer button to stop the presently displayed cook timer.

Cooking Display (SP-11)

This mode lets the operator set up the display during a Cook Cycle.

- a. Follow steps 1 and 2 above.
- b. Press the PROG button until “SP-11” and “COOKING DISPLAY” shows in the display.
- c. The first option, “1,TIME”, sets the display to read only the time remaining during a Cook Cycle.
- d. The second option, “2,TM+ID”, sets the display to read both the time remaining in the Cook Cycle and also the product ID.(i.e., “FF=French Fries”)
- e. The third option, “3,NM+TM”, sets the display to alternate between showing the name of the product being timed, and the time remaining in the Cook Cycle.

Quality Timer Display (SP-12)

This mode lets the operator set up the display during the quality timer countdown.

- a. Follow steps 1 and 2 above.
- b. Press the PROG button until “SP-12” and “QUALITY TMR DISPLAY” show in the display.
- c. The first option, “1,NONE”, means that the display will not show the quality time remaining after a Cook Cycle. The only way to view the quality time remaining is to push the INFO button.
- d. The second option, “2,QT+ID”, sets the display to constantly show the quality time remaining and the product ID that the quality time is holding for after a Cook Cycle.
- e. The third option, “3,NM+QT”, sets the display to alternate between the name of the product the timer is ready to count down for, and the quality time remaining for the product just cooked.

**4-3. SPECIAL PROGRAM
MODE (Continued)**

6 Product Controls Only

Enable 2 products Per Button (SP-13)

This mode is an option that allows the operator to be able to program 2 product times on each button.

- a. Follow steps 1 and 2 above.
- b. Press the PROG button until “SP-13” and “ENABLE 2 PRODS PER BTN?” show in the display. “YES” or “NO” shows on the right side of the display.
- c. Press and release the UP and DOWN arrows to toggle between “YES” and “NO”. If “NO” is displayed, only one product may be programmed per each product button. If “YES” is displayed, two products may be programmed per each product button. They will be displayed as “1A”, “1B”, “2A”, “2B” etc.

12 Product Controls Only

Number of Baskets (SP-13)

This allows the operator to set the controls for use of 1 basket or 2.

- a. Follow steps 1 and 2 above.
- b. Press PROG until “SP-13” and “NUMBER OF BASKETS” show in the display.
- c. Press the UP or DOWN buttons to toggle between “1,BSKT”, or “2,BSKT”.

6 Product Controls Only

Active Quality Timers (SP-14)

- a. Follow steps 1 and 2 above.
- b. Press PROG until “SP-14” and “ACTIVE QUALITY TIMERS” show in the display. “NORMAL” or “DUAL” shows on the right side of the display.
- c. Press the UP or DOWN buttons to select “NORMAL” or “DUAL”. “NORMAL” allows only one quality timer to run at a time. “DUAL” allows 2 quality timers to run simultaneously.

12 Product Controls Only

Auto-lift Detection (SP-14)

- a. Follow steps 1 and 2 above.
- b. Press PROG until “SP-14” and “AUTOLIFT” show in the display.
- c. Keep the controls set at “1,DETECT” for the controls to automatically detect the auto-lift or not.

**4-3. SPECIAL PROGRAM
MODE (Continued)**

- d. Press the UP or Down buttons to select “2,*OFF*”, to disable the auto-lift. This can be used to bypass the auto-lift mechanism, if the auto-lift becomes disabled.
- e. Press the UP or Down buttons to select “3,*ON*”, to force the auto-lift feature, if the controls are not detecting the auto-lift.

Program Code Change (SP-15)

This allows the operator to change the program code (factory set at 1, 2, 3) used to access Product Programming, Special Programming, Clock Set, Data Comm, and Heat Control Modes.

- a. Follow steps 1 and 2 above.
- b. Press PROG until "SP-15" and "CHANGE, MGR CODE? 1=YES" shows in display, along with "CODE".
- c. Press . "ENTER NEW CODE, P=DONE, I=QUIT" shows in display. Press product buttons with new code.
- d. If satisfied with code, press PROG. "REPEAT NEW CODE, P=DONE, I=QUIT, shows in display. Press same code buttons in step c.
- e. If satisfied with code, press PROG. "*CODE CHANGE*" shows in display.
- f. If not satisfied with code, press INFO and "*CANCELLED*" shows in display, then reverts back to "SP-15" and "CHANGE, MGR CODE? 1=YES". Then the above steps can be repeated.

Usage Code Change (SP-16)

This allows the operator to change the reset usage code (factory set at 1, 2, 3) to reset the usage amounts of each product. See Review Usage step in Information Mode.

- a. Follow steps 1 and 2 above.
- b. Press PROG until SP-16" and "CHANGE, USG CODE ? 1=YES" shows in display, along with "USAGE".
- c. Press , "ENTER NEW CODE, P=DONE, I=QUIT" shows in display. Press product buttons with new code.
- d. If satisfied with code, press PROG. "REPEAT NEW CODE, P=DONE, I=QUIT" shows in display. Press same code buttons in step c.

**4-3. SPECIAL PROGRAM
MODE (Continued)**

- e. If satisfied with code, press PROG. “*CODE CHANGE*” shows in display.
- f. If not satisfied with code, press INFO and *CANCELLED* shows in display, then reverts back to "SP-16" and "CHANGE USG CODE ? 1=YES". Then the above steps can be repeated.

Change Shortening-A-Cook Cycles (SP-17)

The operator can set a reminder to filter the shortening, based on the number of Cook Cycles accumulated. The display shows “CHANGE OIL SOON” when the preset number of Cook Cycles has been met, “OFF” to 5000, increments of 10.

- a. Follow steps 1 and 2 above.
- b. Press PROG until "SP-17" and "CHANGE OIL' A – COOK CYCLES” shows in display, along with a number of Cook Cycles.
- c. Press and release UP and DOWN buttons to change the number of Cook Cycles.

Change Shortening-B-Hours (SP-18)

The operator can set a reminder to filter the shortening, based on the number of power-on hours accumulated. The display shows “CHANGE OIL SOON” when the preset number of hours has been met, “OFF” to 999 hours.

- a. Follow steps 1 and 2 above.
- b. Press PROG until "SP-18" and "CHANGE OIL' B – HOURS” shows in display, along with a number of hours.
- c. Press and release UP and DOWN buttons to change the number of power-on hours.

NOTICE

Once the shortening is filtered, to clear the display of “CHANGE OIL SOON” (SP-17 & SP-18), reset the review usage data in the Information Mode. See Information Mode section of this manual.

**4-3. SPECIAL PROGRAM
MODE (Continued)**

Energy Save Enabled? (Gas fryers only) (SP-19)



The Energy Save mode reduces energy used during idle (non-cooking) periods by turning off the blower (draft fan) and pilot flame when possible.

- a. Follow steps 1 and 2 above.
- b. Press PROG until "SP-19" and "ENERGY SAVE ENABLED ? <GAS FRYERS>" shows in display, along with "YES/NO" option.
- c. Press and release UP and DOWN buttons to change from "NO" (default) to "YES", or vice-versa.

Press and hold PROG at any time to exit Special Program Mode.



Clean-Out Minutes (Sp-20)

This allows you to set the number of minutes of the Clean-Out Mode.

- a. Follow steps 1 and 2 above.
- b. Press  until "SP-10" and "CLEAN-OUT MINUTES" shows in display, along with the preset minutes.
- c. Press   to change the number of minutes, up to 99.

Clean-Out Temperature (Sp-21)

This allows you to set the temperature of the Clean-Out Mode.

- a. Follow steps 1 and 2 above.
- b. Press  until "SP-11" and "CLEAN-OUT TMP" shows in display, along with the set temperature.
- c. Press   to change the temperature, up to 212°F (100°C).

**4-4. DATA LOGGING, HEAT
CONTROL, TECH, AND
STAT MODES**

The Data Logging, Heat Control, Tech, and Stat modes are advanced diagnostic and program modes, mainly for Henny Penny use only. For more information on these modes, contact the Service Department at 1-800-417- 8405 or 1-937-456-8405.

SECTION 5. TROUBLESHOOTING

5-1. TROUBLESHOOTING GUIDE

Problem	Cause	Correction
POWER switch ON but fryer completely inoperative	<ul style="list-style-type: none"> • Open circuit 	<ul style="list-style-type: none"> • Plug fryer in • Check breaker or fuse at supply box
Shortening will not heat but lights are on	<ul style="list-style-type: none"> • Open high limit circuit Error message “E-10” • Drain valve open Error message “E-15” 	<ul style="list-style-type: none"> • Reset high limit per High Temperature Limit Control section • Turn drain valve handle to closed position
Foaming or boiling over of shortening	<ul style="list-style-type: none"> • Water in shortening • Improper or bad shortening • Improper filtering • Improper rinsing after cleaning the fryer 	<ul style="list-style-type: none"> • At end of cook cycle, drain shortening and clean • Use recommended shortening • Refer to the procedure covering filtering the shortening • Clean and rinse the frypot, then dry thoroughly
Shortening will not drain from frypot	<ul style="list-style-type: none"> • Drain valve clogged with crumbs 	<ul style="list-style-type: none"> • Open valve, force cleaning brush through drain
Filter switch ON but motor does not run	<ul style="list-style-type: none"> • Motor thermal protector tripped 	<ul style="list-style-type: none"> • Reset thermal switch per section on Filter Pump Motor Protector – Manual Reset

NOTICE

More detailed troubleshooting information is available at 1-800-417-8405 or 1-937-456-8405.

5-2. ERROR CODES

In the event of a control system failure, the digital display shows an error message. The message codes are shown in the DISPLAY column below. A constant tone is heard when an error code is displayed, and to silence this tone, press any button.





DISPLAY	CAUSE	PANEL BOARD CORRECTION
“E-4”	Control board overheating	Turn switch to OFF position, then turn switch back to ON; if display shows “E-4”, the control board is getting too hot; check the louvers on each side of the unit for obstructions
“E-5”	Shortening overheating	Turn switch to OFF position, then turn switch back to ON; if display shows “E-5”, the heating circuits and temperature probe should be checked
“E-6A”	Temperature probe open	Turn switch to OFF position, then turn switch back to ON; if display shows “E-6A”, the temperature probe should be checked; to replace, refer to Technical Manual
“E-6B”	Temperature probe shorted	Turn switch to OFF position, then turn switch back to ON; if display shows “E-6B”, the temperature probe should be checked; to replace, refer to Technical Manual
“E-10”	High limit	Reset the high limit by manually pushing up on the red reset button; if high limit does not reset, high limit must be replaced; refer to Technical Manual
“E-15”	Drain switch failure	Close drain, using the drain valve handle. If display still shows “E-15”, check the drain microswitch; refer to Technical Manual
“E-41”, “E-46”	Programming failure	Turn switch to OFF, then back to ON; if display shows any of the error codes, try to reinitialize the control (Special Program Mode section); if error code persists, replace the control board; refer to Technical Manual
“E-20A”	Air pressure switch failure (stuck closed)	Press the Timer button to try the ignition process again; if “E-20A” persists check the air switch; refer to Technical Manual
“E-20B”	Draft fan or air pressure switch failure (stuck open)	Press the Timer button to try the ignition process again; if “E-20B” persists, check the air switch or the blower motor; refer to Technical Manual

5-2. ERROR CODES (Continued)

DISPLAY	CAUSE	PANEL BOARD CORRECTION
“E-20C”	Ignition modules not responding	Press the timer button to try the ignition process again; if “E-20C” persists, check the ignition module, the spark ignitor, or the I/O board; refer to Technical Manual
“E-20D”	Pilots not lit or no flame sense	Press the timer button to try the ignition process again; if “E-20D” persist, check the ignition module, the I/O board, or the flame sensor; refer to Technical Manual
“E-31”	Fan jumper wire missing	Check for jumper wire on 12-pin connector & add if missing
“E-47”	Analog converter chip or 12 volt supply failure	Turn switch to OFF, then back to ON; if “E-47” persists, have the I/O board, or the PC board replaced; if speaker tones are quiet, probably I/O board failure; refer to Technical Manual
“E-48”	Input system error	Have PC board replaced
“E-54”	PCB component failure	Turn switch to OFF position, then turn switch back to ON; if “E-54” persists, have PCB replaced
“E-70”	Faulty power switch, or switch wiring; faulty I/O board	Have POWER switch checked, along with its wiring. Have Input/Output board replaced if necessary
“E-70A” (C1000)	Fan switch jumper missing	Have jumper wire checked on 12 pin connect to panel
“E-70D” (C1000)	MV jumper missing	Have jumper wire checked on connectors to panel
“E-92”	24-VAC fuse on I/O open	24-VAC fuse on I/O board open; check for shorted component in 24 volt circuit. (i.e., hi limit, drain switch, air switch)

SECTION 6. INFORMATION MODE – 6 & 12 PRODUCT CONTROLS

6-1. INFORMATION MODE FUNCTIONS

This mode gathers and stores historic information on the fryer and operator’s performance. Press  and  at the same time and “*INFO MODE*” shows on display. Press  or  to access the steps and press  to view the statistics within each step. Information Mode is intended for technical use, but the operator can view the following information:

1. **E-LOG** - last 11 errors and time they occurred
2. **LAST LOAD-L** - information about the most recent Cook Cycle, or the cycle presently in progress, on the left basket
3. **LAST LOAD-R** - information about the most recent Cook Cycle, or the cycle presently in progress, on the right basket
4. **DAILY STATS** - information for the last 7 days
5. **REVIEW USAGE**- information accumulated since the last time this data was manually reset
6. **INP A_VHDSF_M** - provides test of fryer inputs
7. **OUTP** - shows the state of heater and pressure
8. **OIL TMP** - temperature of shortening
9. **CPU TMP** - temperature of PC board
10. **ANALOG** - status of controller’s a-to-d converter
11. **AUTOLIFT** - shows status of autolift system (if applicable)

NOTICE

Press and hold  to exit Information Mode at any time, or after 2 minutes, controls automatically exit back to normal operation.

1. E-LOG (error code log)

Press  and “1A. (date & time) *NOW*” shows in display. This is the present date and time.

Press  and if an error was recorded, “1B. (date, time, and error code information)” shows in display. This is the latest error code that the controls recorded.

**6-1. INFORMATION MODE
FUNCTIONS (Continued)**

Press  and the next latest error code information can be seen. Up to 10 error codes (1B to 1K) can be stored in the E-LOG section.

Press  to continue to LAST LOAD.

2. LAST LOAD - L

Press  to view the following information from the most recent Cook Cycle, in the left basket.

FUNCTION	DISPLAY EX:	LEFT
Time of day the last Cook Cycle was started	STARTED 10.25A	
Product (Last product cooked)	PRODUCT -2-	
Ready? (Was fryer Ready before start?)	READY? YES	
Stopped: Time remaining, or secs past Done	*DONE* + 9 SECS	
Actual Elapsed cook Time (Real seconds)	ACTUAL TIME 7:38	
Programmed cook Time	PROG TIME 7:00	
Actual Time vs. Prog time (Percentage)	ACT / PROG 109%	
Max Temp during Cook Cycle	MAX TEMP 327°F	
Min Temp during Cook Cycle	MIN TEMP 313°F	
Avg Temp during Cook Cycle	AVG TEMP 322°F	
Heat On (percentage) during Cook Cycle	HEAT ON 73%	

Only if Presently Cooking:

Present cook step, setpoint, and time rem.	STEP 1:325°F 6:47	
Actual shortening temp, deg below load comp avg, present stretch time (real secs / ck sec)	313°F LC-12° 1.06	

Press  to continue to LAST LOAD - R.

**6-1. INFORMATION MODE
FUNCTIONS (Continued)**

3. LAST LOAD - R

Press  to view the following information from the most recent Cook Cycle, in the right basket.



FUNCTION	DISPLAY EX:	RIGHT
Time of day the last Cook Cycle was started	STARTED 10.25A	
Product (Last product cooked)	PRODUCT -2-	
Ready? (Was fryer Ready before start?)	READY? YES	
Stopped: Time remaining, or secs past Done	*DONE* + 9 SECS	
Actual Elapsed cook Time (Real seconds)	ACTUAL TIME 7:38	
Programmed cook Time	PROG TIME 7:00	
Actual Time vs. Prog time (Percentage)	ACT / PROG 109%	
Max Temp during Cook Cycle	MAX TEMP 327°F	
Min Temp during Cook Cycle	MIN TEMP 313°F	
Avg Temp during Cook Cycle	AVG TEMP 322°F	
Heat On (percentage) during Cook Cycle	HEAT ON 73%	

Only if Presently Cooking:

Present cook step, setpoint, and time rem.	STEP 1:325°F 6:47	
Actual shortening temp, deg below load comp avg, present stretch time (real secs / ck sec)	313°F LC-12° 1.06	

Press  to continue to DAILY STATS.

4. DAILY STATS (reset each day)

Press  to view the following operation information for any of the last 7 days. Press  to select which day.

FUNCTION	DISPLAY EX:
Day this data was recorded for	TUE* APR-30
Number of Hours:Minutes the fryer was on	TUE* ON HRS 13:45
Total number of cook cycles that day	TUE* TOTAL CK 38
Number of cycles stopped before *DONE*	TUE* QUIT CK 2
Cook Cycles for Product #1	TUE* COOK -1L- 17
Cook Cycles for Product #2	TUE* COOK -2L- 9
Cook Cycles for Product #3	TUE* COOK -3L- 5
Cook Cycles for Product #4	TUE* COOK -4L- 0
Cook Cycles for Product #5	TUE* COOK -5L- 0
Cook Cycles for Product #6	TUE* COOK -6L- 6
Cook Cycles for Product #1	TUE* COOK -1R- 0
Cook Cycles for Product #2	TUE* COOK -2R- 0
Cook Cycles for Product #3	TUE* COOK -3R- 1
Cook Cycles for Product #4	TUE* COOK -4R- 0
Cook Cycles for Product #5	TUE* COOK -5R- 0
Cook Cycles for Product #6	TUE* COOK -6R- 0

Press  to continue to REVIEW USAGE.

**6-1. INFORMATION MODE
FUNCTIONS (Continued)**

5. REVIEW USAGE

Press  to view the accumulated information since the data

was manually reset:

FUNCTION	DISPLAY EX:
Day the usage data was previously reset	SINCE APR-19
Number of hours the fryer was on	PWR ON HRS 165
Total number of cook cycles	TOTAL CK 462
Cook Cycles stopped before "DONE"	QUIT COOK 4
Oil Wear based on Number of Cook Cycles	OIL WEAR 'A' 83%
Oil Wear based on Running Hours	OIL WEAR 'B' 55%
Cook Cycles for Product #1	COOKED -1L- 193
Cook Cycles for Product #2	COOKED -2L- 107
Cook Cycles for Product #3	COOKED -3L- 58
Cook Cycles for Product #4	COOKED -4L- 0
Cook Cycles for Product #5	COOKED -5L- 13
Cook Cycles for Product #6	COOKED -6L- 69
Cook Cycles for Product #1	COOKED -1R- 0
Cook Cycles for Product #2	COOKED -2R- 7
Cook Cycles for Product #3	COOKED -3R- 15
Cook Cycles for Product #4	COOKED -4R- 0
Cook Cycles for Product #5	COOKED -5R- 0
Cook Cycles for Product #6	COOKED -6R- 0
Reset usage data: Enter the Usage Code (1, 2, 3 unless changed) on this step to zero out all the usage information	RESET USG / ENTER CODE - - - - -

Press  to continue to INP A_VHDSF_M.

6. INP A_VHDSFPM

Press  to view the status of components and inputs. If the

input signal is detected, an identifying letter is displayed (see below). If the signal is not detected, “_” is displayed.

With the COOK /PUMP switch in the COOK position, and all inputs detected, “A_VHDSF_M” shows in the display (“A_VHDSFP_” for gas units). See below for definition of codes.

A = Power Switch in ON position.

V = Volts - 24 VAC detecte

H = HIGH LIMIT -- If "H" is present, the high limit is good.
If "H" is missing, the high limit is tripped out (overheated) or disconnected.

D = DRAIN SWITCH-If “D” is present, the drain handle is closed. If “D” is missing, the drain is open or faulty.

6-1. INFORMATION MODE
FUNCTIONS (Continued)

S = ON/OFF switch “on” interlock circuit: If “S” is present, ON/OFF switch is in the ON position. If the “S” is missing, the power switch is either off, failed, or wired incorrectly.

F = FAN (gas fryers)

P = (PILOT VALVE) -- On Gas fryers this signal comes from the Ignition Module PV output.

M = (MAIN VALVE) – On Gas fryers this signal comes from the Ignition Module MV output.

Press  to view the specific status of each input. An underscore (“_”) indicates the input is not presently detected. A Checkmark (“√”) indicates the signal is detecting a normal input. A blinking (“X”) indicates the signal is presently detected, but is detected as a half-wave (partially failed) input.

NOTICE

The V, H, D, S, F, P and M signals below are wired in series. The first signal missing out of this sequence I generally causes all signals to the right of it to be missing as well.

Press  to continue onto OUTP H*.

7. OUTP ELEC: H* GAS: F*I*H

This mode displays the status of components and outputs. If the output signal is detected, an identifying letter is displayed (see below), followed by an “*”. If the output is off, “_” is displayed.

F = Fan output (gas only)

I = Ignition module output (gas only)

H = Heat output

On gas units, if fan is on, “F*” shows in display. If fan is off, “F_” shows in display. If controls senses a problem with the fan output, “F*” shows in display, with the “*” flashing.

On gas units, if power is to module, “I*” shows in display. If no power is to module, “I_” shows in display. If controls senses a problem with the module output, “I*” shows in display, with the “*” flashing.

If heat is on, “H*” shows in display. If heat is off, “H_” shows in display. If controls sense a problem with the heat output, “H*” shows in display, with the “*” flashing.

Press  to view the amp “DRAW” status of each output. “F √”, “H √” and “P √” in the display means the amps are good. A flashing “X” behind the F, H or P means too much current.

**6-1. INFORMATION MODE
FUNCTIONS (Continued)**

Press  to view the No Connect/Ground (“NC/GND”) status of each output. This monitors a possible problem with the relays on the output PC board.

“F √”, “H √” and “P √” in the display means everything on the output PC board is good. A flashing “X” behind the F, H or P means a problem exists.

Press  to view the outputs and inputs (see step 10) together.

Press  to continue onto the OIL TMP reading.

8. OIL TMP

This step shows the present peanut shortening temperature. The display shows “7. OIL TMP (temp.)”.

Press  to continue onto the CPU TMP reading.

9. CPU TMP

This step shows the present PC board temperature.

Press  to continue on to the ANALOG reading.

10. ANALOG <1> 2.86V

This step displays the present status of any channel of the controller’s a to d converter. This feature may be useful to a technician troubleshooting a problem with the fryer or controller.

The displayed value can be toggled between volts and bits by pressing . If the displayed value has a decimal point, it is voltage (0 to 5 VDC). If no decimal point is shown, the value is a-to-d bits (0 - 4095).

Press  to continue onto AUTOLIFT/DETECT.

10. AUTOLIFT/DETECT=

This step shows the status of the autolift system, if installed. The display indicates “Detect=Yes” if an autolift system is detected; otherwise, it displays “Detect=No”.

The letter following the “L” indicates the status of the left- side autolift motor: “u” = up, “d” = down. Similarly, the letter following the “R” indicates the status of the right-side autolift motor.

NOTICE

Press and hold  to exit Information Mode at any time, or after 2 minutes, controls automatically exit back to normal operation.

G L O S S A R Y
HENNY PENNY OPEN FRYERS

air valve	a valve on the eight head fryer that allows air into the filter lines when the pump is on in the mixing mode on eight head fryers
airflow switch (<i>gas fryers only</i>)	a switch that senses the amount of airflow coming from the blower; if the airflow falls below a certain level, the switch cuts power to the gas control valve that shuts down the burners
blower (<i>gas fryers only</i>)	located on the rear of a gas fryer, the blower pulls flue gases out of the flue and provides the proper amount of air to the burner tubes for efficient combustion
breeding	a flour and seasoning mixture used to coat the product prior to frying
burner assembly (<i>gas fryers only</i>)	an assembly on gas fryers that houses the pilot light which ignites the gas that heats the fryer
burner tubes (<i>gas fryers only</i>)	the tubes through which heated air is forced to heat the shortening
carrier	a wire frame inside the eight head frypot that holds five racks of product during the cook cycle
casters	the wheels on bottom of the fryer that allow the unit to roll; casters should be locked when unit is in use and not being moved; casters may be adjusted to help level the fryer
cleaning solution	an agent used to clean the frypot; see recommended cleaning procedures
cold zone	an area in the bottom of the frypot where shortening is cooler than the area above; the zone allows the crumbs to settle without burning
cook cycle	a programmed cycle that cooks a particular product at a preselected temperature and for a preselected time
cooking load	the amount of product cooked during a cook cycle
counterweight	the weights shipped with the fryer that, when installed in the counterweight assembly, enable the eight head fryer lid to lift easily
counterweight assembly	an assembly of weights and cables that enable the eight head fryer lid to lift easily
cover	a protective lid for the frypot when fryer is not in use
cracklings	the crumbs of breading that come off the product during a cook cycle
crumb catcher	the part of the filter assembly on four head fryers that filters crumbs out of the shortening before the shortening is pumped back into the frypot

data plate	a label or plate located on the right side panel of the fryer that indicates the fryer type, serial number, warranty date, and other information
drain handle	the handle used to open and close the drain valve
drain interlock switch	a microswitch that automatically shuts off the fryer heat in the event the drain valve is inadvertently opened while the fryer power switch is in the ON position
drain valve	a valve that allows the shortening to drain from the frypot into the filter drain pan; the fryer power switch should be in the OFF position before the drain valve is opened; the drain valve should remain closed at all other times
dumping table	a table onto which the cooked product is dumped after removal from the frypot
fill lines	the four lines marked on the interior rear wall of the frypot that show the proper shortening level (<i>also referred to as level indicator lines</i>)
filter clips	the clips are the part of the filter screen assembly that holds the filter envelope closed
filter drain pan	a pan that slides under the fryer into which shortening is drained
filter envelope	a fiber envelope into which the filter screen is placed; the end of the envelope is folded and held closed with filter clips; a part of the filter screen assembly
filter heater switch	control panel switch that activates the strip heater (<i>Model OE-100 only</i>)
filter pan dolly	an optional transport cart for the filter drain pan
filter pump motor	the motor that powers the filtering system
filter screen assembly	an assembly that filters the shortening as it is pumped from the frypot; the assembly is made up of two filter screens, a filter envelope, two filter clips, and a crumb catcher (<i>Note: eight head fryers have two filter screens with no crumb catcher</i>)
filter union	the threaded connection between the fryer and the filter system that can be connected or released without tools
filter valve	the valve that must be opened to pump shortening back into the frypot during the filter cycle (<i>Models OE-100, 320, and 340</i>)
flame sensors (<i>gas fryers only</i>)	the sensors that shut off the gas supply to gas fryers if the pilot lights go out or do not light
fryer brush	a brush included with the fryer used to scrub the inside of the frypot
frypot	the interior portion of the fryer that holds the shortening and the product while cooking
frypot collar	the top flat surface area around the fryer lid

gas control valve (<i>gas fryers only</i>)	an automatic dual controller that controls gas to both pilot lights and gas pressure to burners on fryers; if either pilot light goes out, the controller shuts off the gas to the other pilot light
gas valve knob (<i>gas fryers only</i>)	the knob that opens and closes the gas control valve
gas pressure regulator (<i>gas fryers only</i>)	a device located on the gas control valve that regulates the gas pressure; the pressure specifications are preset at the factory
heat indicator	the light that illuminates when the shortening is being heated; the light goes off when the preset shortening temperature has been achieved
heating elements	the coils located inside the frypot on electric fryers that heat the shortening
high limit	a temperature control that opens and shuts off the heat to the frypot if it senses shortening temperature in excess of 420°F (216°C)
ignition modules	two modules that send electrical energy to the spark igniters that ignite the pilot lights on gas fryers
L-shaped brush	a brush included with the fryer that is used to clean around the burner tubes and heating elements
landing table	another name for a dumping table (<i>see dumping table</i>)
level indicator lines	the lines marked on the interior rear wall of the frypot that show the proper shortening level (<i>also referred to as fill lines</i>)
lid assembly	an assembly comprised of lid, lid handle, and lid latch which raises and lowers product into shortening on eight head fryers
lid handle	a handle that is attached to the lid and is used to lower the lid into contact with the frypot; the handle is then pulled forward and pushed down to lock the lid in place (<i>see lid latch</i>)
lid latch	a mechanical catch on the front of the fryer lid that engages a bracket located on the front of the frypot; the latch holds the lid down
manual reset lever	resets high limit (<i>OE-100 only</i>)
manual shutoff valve (<i>gas fryers only</i>)	a valve located between the fryer and the wall that shuts off the flow of gas from the supply line; this is not the main shutoff valve for the store
melt cycle	a heat mode that cycles on and off to slowly melt the shortening when the power switch is on and the shortening temperature is below a certain temperature; the melt cycle prevents scorching of the shortening
pilot orifice (<i>gas fryers only</i>)	a controlled opening for the pilot light located on the burner assembly
pilot light (<i>gas fryers only</i>)	a small flame that remains burning even when the fryer is not in use; the flame ignites the gas when the fryer is turned on

power/pump switch	a three-way switch located on the front control panel of the fryer that serves as an off/on switch and a filter switch
product	a food item cooked in the fryer
rack	the wire grid that slides into the carrier to hold product during the cook cycle
setpoint	a preset cooking temperature; the setpoint is a programmable feature
shortening mixing system	an automatic system on eight head fryers that periodically uses the filter pump to mix the shortening in the frypot to prevent an accumulation of moisture to minimize the boiling action in the frypot
shortening shuttle	optional equipment used for shortening disposal
sift breading	the process of removing clumps from breading
spark igniters (<i>gas fryers only</i>)	the igniters that create a spark to ignite the pilot lights on gas fryers (<i>see ignition modules</i>)
standpipe	the pipe through which shortening is pumped back into the frypot after the filtering process is complete
standpipe assembly	the pipe and fittings that are part of the shortening filtering process
straight brush	a brush that is included with the fryer that is used to clear the drain in the bottom of the frypot
strip heater	keeps the filter lines free of solidified shortening when the filter heater switch is turned on (<i>Model OE-100 only</i>)
temperature probe	a round probe that is located in the inside of the frypot that measures the temperature of the shortening in the frypot; the probe communicates with the control panel
thermal protector	overheat protection switch for the filter motor that must be manually reset if tripped



Henny Penny Corporation
P.O.Box 60
Eaton, OH 45320

1-937-456-8400
1-937-456-8402 Fax

Toll free in USA
1-800-417-8417
1-800-417-8434 Fax

www.hennypenny.com