



Responsive, Reliable Solutions

# INFERNO 3500

Gas-Fired, Self-Cleaning Rotisserie for CA/MX/US

## Operation Manual



Hardt Equipment Manufacturing Inc.  
1400 50<sup>th</sup> Avenue, Lachine (Montreal)  
Quebec, Canada, H8T 2V3

#### Technical Support

Tel: (800) 387-6847

(514) 631-7271

Fax: (514) 631-5443

#### Sales

Tel: (888) 848-4408

[www.hardtequipment.com](http://www.hardtequipment.com)

This manual is to be left with the customer for future reference.

CUS-013-0027-03

## 1. Important Information

### **FOR YOUR SAFETY**

**Do not store or use gasoline or other flammable vapors and liquids in the vicinity of this or any other appliance. Keep the area around the appliance free from all combustible material.**

### **WARNING**

**Improper installation, adjustment, alteration, service, or maintenance can cause property damage, injury, or death.**

**Read the installation, operating, and maintenance instructions thoroughly before installing or servicing this equipment.**

### **IMPORTANT**

**You must post in a prominent location, instructions to be followed in the event that the user smells gas. Specific instructions can be obtained from your local gas supplier.**

### **NOTE**

**Hardt implements continuous improvements of its products and reserves the right to change without notice.**

**Images shown in this manual are for reference only and may appear different from actual models.**

# Table of Contents

<b>1. Important Information</b> .....	<b>2</b>
<b>2. Before you Begin</b> .....	<b>4</b>
2.1 About This Manual .....	4
2.2 Equipment Safety .....	4
2.3 Food Safety .....	5
<b>3. Equipment Diagrams</b> .....	<b>6</b>
3.1 Single Rotisserie .....	6
3.2 Single Top Vent Rotisserie .....	7
3.2.1 Double-Stacked Rotisserie .....	8
3.3 Control Panel Layout .....	9
<b>4. Operation</b> .....	<b>10</b>
4.1 Morning Startup .....	10
4.1.1 Starting the Rotisserie .....	10
4.1.2 Running a Preheat Cycle .....	11
4.2 Cooking Procedure .....	11
4.2.1 Loading and Starting a Cook Cycle .....	11
4.3 End of the Cook .....	12
4.4 Loading and Unloading the Rotisserie .....	13
4.4.1 Loading the Skewers .....	13
4.4.2 Unloading the Skewers .....	14
4.5 Available Accessories .....	14
4.6 Controller Functions .....	15
4.6.1 Notifications and Alarms .....	15
4.6.2 Programming .....	15
4.6.3 Programming Favorites .....	15
<b>5. Maintenance</b> .....	<b>16</b>
5.1 Daily Cleaning .....	16
5.1.1 Beginning of the Day .....	16
5.1.2 Cleaning Throughout the Day .....	16
5.1.3 Cleaning at the End of the Day .....	16
5.1.4 Description of Operation .....	16
5.1.5 Auto Clean Operation .....	17
5.1.6 Auto Clean Effectiveness Evaluation .....	19
5.2 Weekly Inspection .....	20
5.3 Material Cleaning Guidelines .....	20
5.3.1 Guidelines for Cleaning Glass Surfaces .....	20
5.3.2 Guidelines for Cleaning Metal Surfaces .....	20
<b>6. Troubleshooting</b> .....	<b>21</b>
6.1 Rotisserie Does Not Operate .....	21
6.2 Safety Lockout .....	22
6.3 Replacing the Halogen Light Bulb .....	23
6.4 Numeric Temperature Display Mode .....	24

## 2. Before you Begin

### 2.1 About This Manual

This manual contains information necessary for the operation of the HARDT Equipment Manufacturing (hereafter referred to as Hardt) Inferno 3500 rotisserie. Retain this manual for future reference. To help the reader in the utilization of this manual, certain information has been highlighted using the following conventions:



**INFORMATION THAT REFERS TO ACTIONS WHICH MAY HAVE CONSEQUENCES POTENTIALLY DANGEROUS TO THE OPERATOR AND/OR THE EQUIPMENT.**



**Information for proper installation and functioning.**



Additional important information.

### 2.2 Equipment Safety



**FAILURE TO FOLLOW THESE SAFETY PRECAUTIONS CAN RESULT IN INJURY, DEATH AND/OR PROPERTY DAMAGE.**



**THERE ARE SOME SAFETY CONSIDERATIONS TO TAKE INTO ACCOUNT WHEN OPERATING THIS EQUIPMENT. IT IS VERY IMPORTANT THAT YOU FULLY UNDERSTAND THIS DOCUMENT AND THE SAFETY PRECAUTIONS WRITTEN HERE.**

- Read all documentation; only people who have read and understand the documentation should use the equipment.
- Do not use this equipment for anything other than its intended use.
- Do not operate this equipment if it is damaged in any way.
- Do not use unauthorized accessories.
- Do not operate this equipment near flammable materials.
- Always check for gas leaks; if detected, vacate the area and call the gas supply company.
- Clean the equipment every day; build-up of waste in the rotisserie can cause fires.
- When the rotisserie is plugged in, there are potentially dangerous voltages present in the control circuits; do not open the electrical compartment as there are potentially lethal voltages present.
- Do not cover any vents.
- Always check for water leaks; do not operate if leaks are visible.
- Do not immerse the cord or plug in water.
- Use only approved detergents.
- Keep hair and loose clothing away from any moving parts.
- Do not work with any hot surfaces without wearing protective gloves and an apron.
- Keep the area around the rotisserie clear of combustibles.
- Any equipment that burns gas carries a risk of producing carbon monoxide; if headaches, dizziness, shortness of breath, nausea, vomiting or confusion are encountered, shut down all equipment and vacate the area. Have the equipment inspected immediately.



**Contact Hardt or an approved service provider immediately if any problems are encountered with your equipment.**



#### **ELECTRICAL GROUNDING INSTRUCTIONS**

**THIS APPLIANCE IS EQUIPPED WITH A THREE-PRONG (GROUNDING) PLUG FOR YOUR PROTECTION AGAINST SHOCK HAZARD AND SHOULD BE PLUGGED DIRECTLY INTO A PROPERLY GROUNDED THREE-PRONG RECEPTACLE. DO NOT CUT OR REMOVE THE GROUNDING PRONG FROM THIS PLUG.**



**This appliance is equipped with a restraint cable. In the event the cable is disconnected for inspection or cleaning, ensure that it is reconnected before you operate the rotisserie.**

## 2.3 Food Safety



**THERE ARE PRECAUTIONS THAT NEED TO BE TAKEN WHEN WORKING WITH RAW MEATS. FAILURE TO FOLLOW PROPER FOOD PREPARATION PROCEDURES CAN RESULT IN ILLNESS AND DEATH. SOME PRECAUTIONS ARE LISTED IN THIS DOCUMENT BUT YOU SHOULD NOT RELY SOLELY ON THIS DOCUMENT FOR FOOD SAFE PROCEDURES. IT IS RECOMMENDED THAT ONLY PERSONS WHO ARE FULLY TRAINED IN FOOD SAFETY SHOULD PREPARE FOOD ITEMS.**

- Wash all surfaces and equipment that comes into contact with raw meat or its juices.
- Always thoroughly wash your hands after working with raw meat.
- Do not allow raw meat or its juices to contact cooked meat.
- Use separate utensils for working with raw and cooked meat.
- Use separate containers/trays for holding raw and cooked meat.
- Always use a clean food thermometer to ensure meat is at a safe temperature before removing from the rotisserie.



**THE TABLE BELOW DESCRIBES HOW LONG EACH TYPE OF MEAT MUST BE AT A SPECIFIC TEMPERATURE TO ENSURE THAT ALL BACTERIA ARE KILLED. ALWAYS USE A CLEAN CALIBRATED FOOD THERMOMETER TO ENSURE THAT YOUR PRODUCT REACHES THESE TEMPERATURES FOR THE SPECIFIED TIME PERIOD BEFORE CONSIDERING IT SAFE FOR CONSUMPTION.**

Table 1

<b>Safe Cooking Times and Temperatures*</b>	
<b>Product</b>	<b>Temperature/Time</b>
Poultry (whole or ground duck, chicken or turkey)	165 °F [74 °C] for 15 seconds
Stuffing and stuffed meat, fish, poultry and pasta	165 °F [74 °C] for 15 seconds
Ground meat (beef, pork, and other meat)	155 °F [68 °C] for 15 seconds
Injected meat (brined ham and flavor injected roasts)	155 °F [68 °C] for 15 seconds
Pork, beef, veal, lamb, steaks/chops	145 °F [63 °C] for 15 seconds
Roast	145 °F [63 °C] for 4 minutes
Seafood (fish, shellfish, crustaceans)	145 °F [63 °C] for 15 seconds
Commercially processed ready-to-eat food	135 °F [57 °C] (Hot held for service)

\*National Restaurant Association, *ServSafe Course book*, Fifth Edition, New Jersey, Prentice Hall, 2008



The values listed in this table are industry standard minimum temperatures to ensure food is safely cooked, and may not represent the temperatures dictated by your company.



**COOKING ANY NEW PRODUCT OR ANY CURRENT PRODUCT PREPARED IN A DIFFERENT WAY REQUIRES A VALIDATION OF COOKING TIMES AND COOKING TEMPERATURES BY MEASUREMENT OF INTERNAL PRODUCT TEMPERATURES.**

**DO NOT ASSUME SAFE COOKING PARAMETERS EXIST WITHOUT PERFORMING FOOD-SPECIFIC REFERENCE SENTENCES. ALWAYS MEASURE THE INTERNAL TEMPERATURE OF A PRODUCT BEFORE ENDING THE COOKING. ACCEPTED INTERNAL TEMPERATURES SHOULD NOT BE LOWER THAN THOSE PUBLISHED FOR ESTABLISHED FOOD SAFETY STANDARDS.**



**Consult Hardt if you need help setting up a food safety program.**

### 3. Equipment Diagrams

#### 3.1 Single Rotisserie

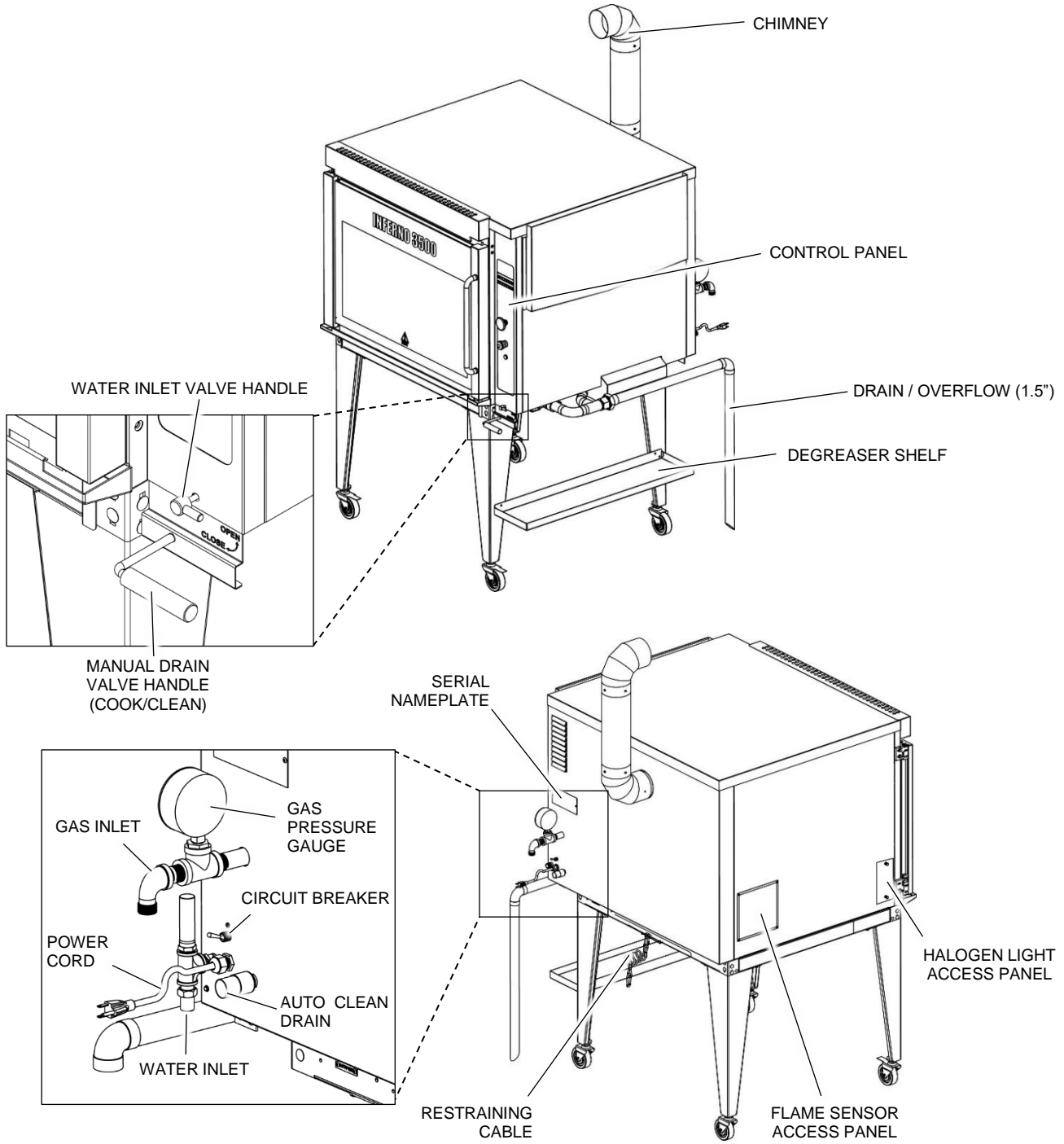

Figure 3-1

For a full list of available accessories, please visit [www.hardtequipment.com](http://www.hardtequipment.com) or contact your sales account representative.

### 3.2 Single Top Vent Rotisserie

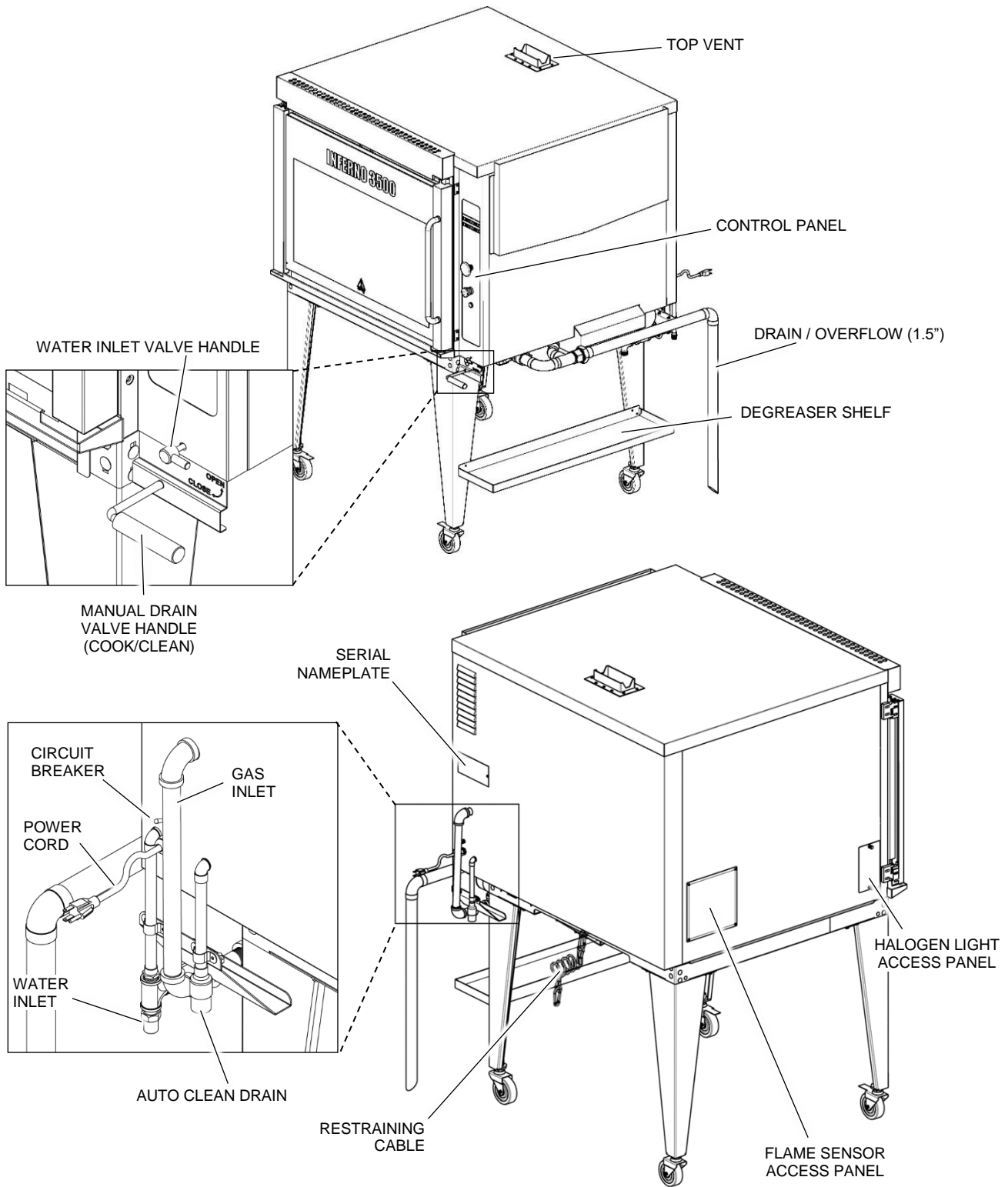

Figure 3-2

For a full list of available accessories, please visit [www.hardtequipment.com](http://www.hardtequipment.com) or contact your sales account representative.

## 3.2.1 Double-Stacked Rotisserie

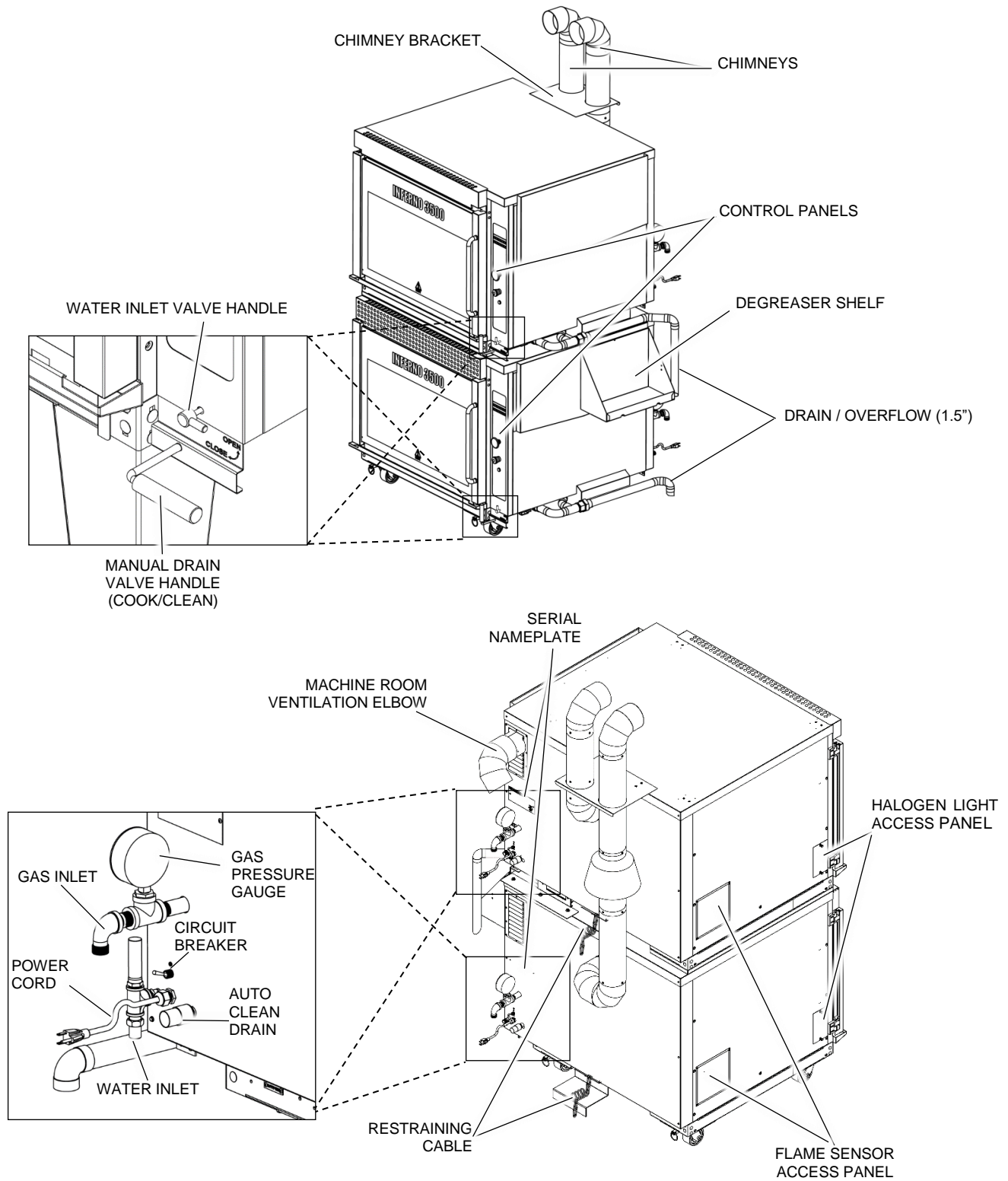

Figure 3-3

For a full list of available accessories, please visit [www.hardtequipment.com](http://www.hardtequipment.com) or contact your sales account representative.

### 3.3 Control Panel Layout

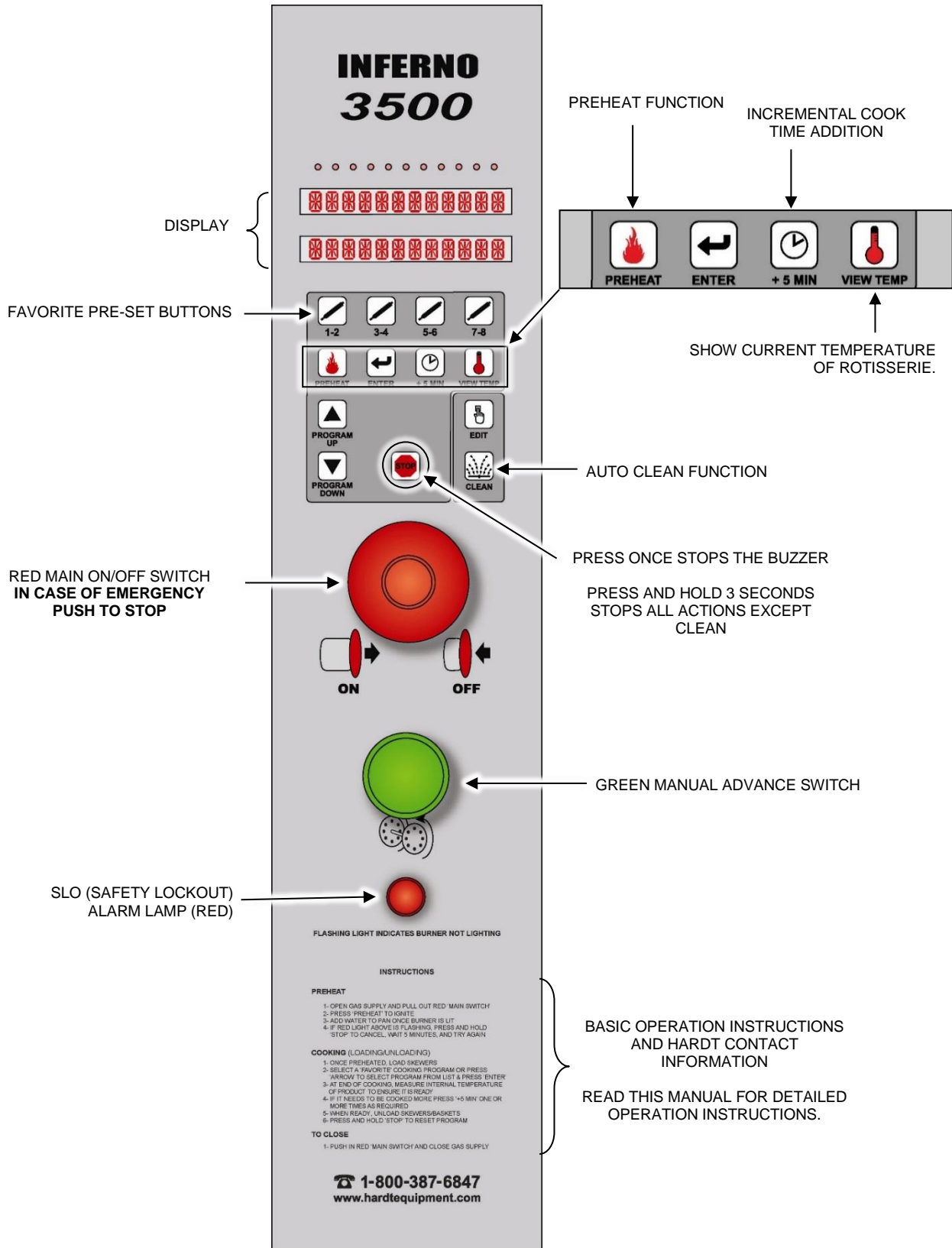

Figure 3-4

## 4. Operation



**THE ROTISSERIE CANNOT BE OPERATED DURING A POWER FAILURE. IN THE EVENT OF A PROLONGED POWER FAILURE, DO NOT ATTEMPT TO OPERATE THE ROTISSERIE. PUSH IN THE RED MAIN ON/OFF SWITCH AND CLOSE THE GAS VALVE. WHEN POWER HAS BEEN RESTORED, OPEN THE GAS VALVE, PULL OUT THE RED MAIN ON/OFF SWITCH AND RESUME NORMAL OPERATION.**

### 4.1 Morning Startup



**ALWAYS TURN VENTILATION SYSTEM ON BEFORE STARTING ROTISSERIE. IT IS REQUIRED TO REMOVE COMBUSTION BY-PRODUCTS AND GREASE-LADEN AIR.**



See section 4.6.2 *Programming* on page 15 for information on how to store quick key programs and other features details.

#### 4.1.1 Starting the Rotisserie

1. Ensure the rotisserie has been properly cleaned from the previous day of use (See section 5.1.6 *Auto Clean Effectiveness Evaluation* on page 19).
2. Make sure the manual drain valve handle is closed (Figure 4-1).
3. Using the water inlet valve handle (Figure 4-1), add water to the oven's water pan, filling it to the top of the overflow drain (Figure 4-2).
4. Position a clean empty grease collection reservoir (grease shuttle, bucket, etc.) under the grease drain of each rotisserie.
5. Make sure the gas valve to the rotisserie is opened.
6. Turn on the ventilation hoods.
7. With the power connected, turn on the rotisserie by pulling out the red main ON/OFF switch.

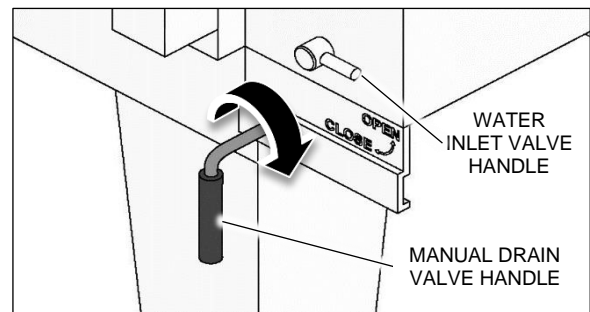

Figure 4-1

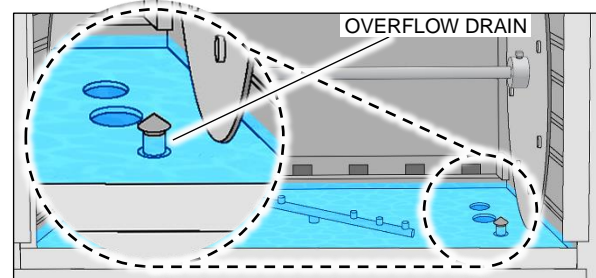

Figure 4-2



The rotisserie is now in "Idle Mode" and is ready for input.

### 4.1.2 Running a Preheat Cycle



**THE ROTISSERIE MUST BE PREHEATED BEFORE ANY COOKING CYCLE.**

1. To activate a pre-programmed preheat cycle, press PREHEAT  on the controller touchpad.



The rotisserie is now in mandatory “Preheat Mode”.

2. Following a preheat cycle (see section 4.1.1); the display will indicate “OVEN READY” when the correct temperature for loading the rotisserie has been reached.



The rotisserie is now in “Oven Ready Mode” and is ready to be loaded.



**If the red SLO (SAFETY LOCKOUT) alarm lamp is flashing, indicating the burner did not light, open the door for 5 minutes and retry. See section 6.2 Safety Lockout on page 22 if the problem continues.**

## 4.2 Cooking Procedure



**THE ROTISSERIE IS HOT. ENSURE YOU ARE WEARING OVEN MITTS AT ALL TIMES WHEN WORKING WITH THE HOT ROTISSERIE.**

- NEVER LOAD PRODUCT INTO A ROTISSERIE WHICH IS NOT PREHEATED.
- CROSS CONTAMINATION OF RAW ONTO COOKED PRODUCT IS VERY DANGEROUS.
- DO NOT LOAD FRESH PRODUCT INTO ROTISSERIE UNTIL COOKING CYCLE IS COMPLETE AND ALL COOKED PRODUCT IS REMOVED FROM ROTISSERIE.







**REFER TO SECTION 2.3 FOOD SAFETY ON PAGE 5 FOR SPECIAL NOTES ON PRODUCT INTERNAL TEMPERATURES.**



**The procedures described here are basic. Hardt provides extensive cooking and food program support and training. Your organization may have specific instructions that should be followed instead of the ones listed here.**

### 4.2.1 Loading and Starting a Cook Cycle

1. Following a preheat cycle (see section 4.1.2 *Running a Preheat Cycle* on page 11); the display will indicate “OVEN READY” when the correct temperature for loading the rotisserie has been reached.
2. Open the door and load the product as per the procedure described in section 4.4.1 on page 13.
3. Close the door.

4. Select a single “FAVORITE PRE-SET” button indicated by either  on the keypad (see Figure 3-4 on page 9) or press an arrow (“UP”  or “DOWN” ) to select another program from the saved list. To select a program, press “ENTER”  on the keypad.

5. After loading, wipe the door handle, control panel, switches and anything that may have come in contact with raw product.



The numbers on the favorite buttons dictate how many skewers are to be used. Select ‘1-2’ if using one or two skewers, select ‘3-4’ if using three or four skewers, etc.

## 4.3 End of the Cook

1. At the end of the cook, measure product internal temperature.



**REFER TO SECTION 2.3 FOOD SAFETY ON PAGE 5 FOR SPECIAL NOTES ON PRODUCT INTERNAL TEMPERATURE.**

2. If the measured internal temperature is insufficient, press + 5 MIN  to add five minutes to the cook cycle. The +5 MIN button can be pressed up to 3 times to add a total of 15 minutes to the cook time.



**REPEAT THIS STEP UNTIL THE CORRECT INTERNAL TEMPERATURE IS REACHED.**

3. Press “STOP”  and hold for 3 seconds to end and reset the program.
4. Unload skewers from rotisserie following the procedure described in section 4.4.2 *Unloading the Skewers on page 14*.
5. Open the water inlet valve to raise the water level. Skim grease down the overflow drain (make sure the liquids flow freely out of the overflow drain).
6. Close the water inlet valve.

## 4.4 Loading and Unloading the Rotisserie



**CROSS CONTAMINATION OF RAW ONTO COOKED PRODUCT IS VERY DANGEROUS. DO NOT LOAD UNCOOKED PRODUCT INTO THE ROTISSERIE UNTIL COOKING CYCLE IS COMPLETE AND ALL COOKED PRODUCT IS REMOVED FROM THE ROTISSERIE.**



**USE PROTECTIVE CLOTHING WHEN LOADING AND UNLOADING THE ROTISSERIE.**

### 4.4.1 Loading the Skewers

When the rotisserie reaches operating temperature skewers can be loaded.

Open the door to shut off burner and to stop the drive rotation. Use the green Manual Advance Switch (as indicated in Figure 3-4 on page 9) to position sockets as required.



**The orientation of the skewer in the socket will vary depending on the model of your equipment.**

Follow these steps to properly load skewers into the rotisserie.

1. As indicated in diagram **A** below, insert pointed end of the skewer into a hole in the plate on left side of rotisserie.
2. Align the other end of the skewer with the corresponding socket and push into place (see diagram **B**).
3. Slide the skewer back to the left until the shoulder of the tip at the left end of the skewer rests against the left end plate.
4. Check that the skewer is secured in position (holds in place).
5. Advance the drive to another position using the green manual advance switch and try to ensure a balanced load. Repeat steps 1-5 as required.
6. Close the door, select the proper cooking program, and the rotisserie will begin to cook.
7. After loading, wipe the door handle, control panel, switches and anything that may have come in contact with raw product.

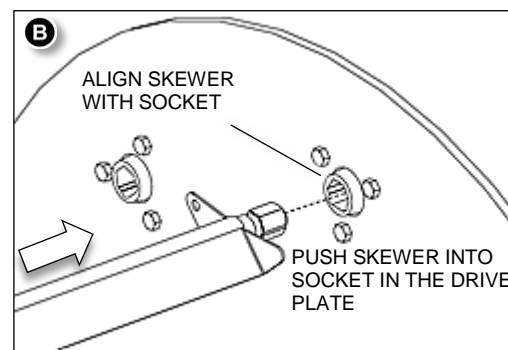
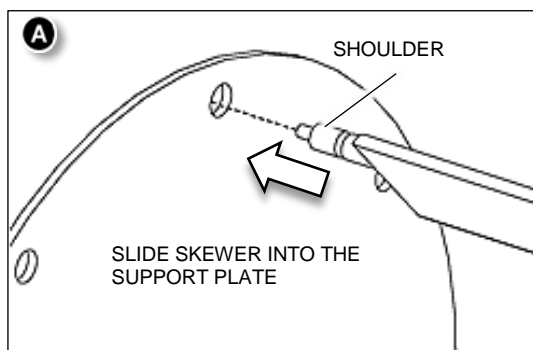



Figure 4-3

### 4.4.2 Unloading the Skewers



**USE PROTECTIVE CLOTHING WHEN LOADING AND UNLOADING THE ROTISSERIE.**

1. Open the door to shut off burner and to stop the drive from rotating.
2. Remove each skewer by lifting left end, sliding the skewer to the left and then gently pivot the skewer out of the rotisserie. Place each skewer on a skewer cart or a cooked food table.
3. Use the green manual advance switch to position skewers (or baskets) as required for removal.
4. Close the door of the rotisserie to resume operation or cooking (burner will reignite).
5. If no further cooking is required, press and hold the “STOP”  button for three seconds to end the program.

## 4.5 Available Accessories

Please refer to the following table when ordering accessories from Hardt.

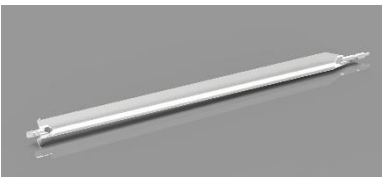
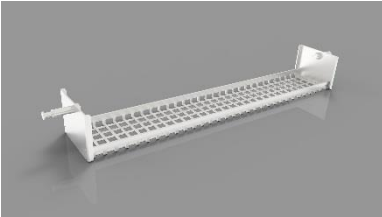
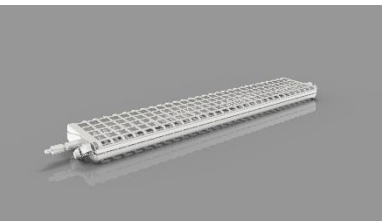

Table 2

Part Name	Description	Illustration
'V' Skewers	This is the 'V' skewer but with a modified end tip so the skewer can only be loaded one way, ensuring correct positioning of the product while cooking.	
Hanging Basket	Designed for products that should not rotate during cooking. The basket stays horizontal while the drive turns.	
Rib Basket	A clamshell basket that is ideal for cooking ribs, chicken parts and a variety of other products.	

## 4.6 Controller Functions

This section contains information for basic operation and programming of the Inferno 3500 system. For more detailed instructions, please refer to the Controls Instruction Manual.





### 4.6.1 Notifications and Alarms

(Press STOP  once to end a buzzer. Press and hold 'STOP'  for 3 seconds to stop any action except an AUTO CLEAN cycle.)

- At the end of a preheat cycle when the correct temperature is reached, a buzzer will sound for 5 seconds.
- If the rotisserie temperature then drops below 150°F (65.6° Celsius), the red alarm lamp will flash and a message on the controller display will prompt to repeat the preheat cycle.
- At the end of a cooking cycle and of subsequent cook time additions, a buzzer sounds for 10 seconds.
- In case of a *Safety Lock Out* (gas burner does not light), the red SLO (Safety Lockout) alarm lamp will flash continuously (shown in Figure 3-4 on page 9).









### 4.6.2 Programming

The controls allow many of the rotisserie's parameters to be accessed and modified. Only the basic programming of "Favorites" is described in this manual. Additional modification of the parameters must be performed by an authorized service technician. Please call Hardt Customer Service for further information.

Use PROGRAM UP / PROGRAM DOWN   to scroll through menus and to change settings, press ENTER  to select (and then again to validate selection) and STOP  to exit.

### 4.6.3 Programming Favorites

A Favorite is a shortcut to a cooking program. To assign a different cooking program to a Favorite button:

1. Hold EDIT  and a single FAVORITE key (either    ) simultaneously for three seconds. (Display shows "P0 / 7-8 SKS MANUAL").
2. Use the PROGRAM UP  or PROGRAM DOWN  buttons to locate any program in memory from 1 to 16.
3. Press ENTER  to save program selection to that Favorite button.

## 5. Maintenance



**ENSURE YOU ARE WEARING INSULATED GLOVES AND AN APRON AT ALL TIMES WHEN WORKING WITH A HOT OVEN.**



**Allow a period of time for the rotisserie to reach a safe-to-touch temperature, but ensure that the oven is still warm to facilitate easier cleaning.**

### 5.1 Daily Cleaning

#### 5.1.1 Beginning of the Day

Ensure that the entire Rotisserie is clean by referring to section 5.1.6 *Auto Clean Effectiveness Evaluation* on page 19. If it is not clean, perform an Auto Clean cycle by following the on-site cleaning laminates or referring to section 5.1.3 *Cleaning at the End of the Day: Auto Clean Operation* on page 16.



**IT IS IMPERATIVE THAT THE ROTISSERIE OVEN IS PROPERLY CLEAN AND SANITIZED FROM THE PREVIOUS DAY. IF AN AUTO CLEAN CYCLE WAS NOT RUN AT THAT TIME, IT MUST BE RUN AT THE BEGINNING OF THE DAY BEFORE A COOK IS INITIATED.**

#### 5.1.2 Cleaning Throughout the Day

It is recommended to clean the inner glass with a soft, damp cloth after every cooking cycle. This will lead to optimal cleaning results without scratching the glass. Do not use scouring pads or abrasive cleaners on glass. Refer to section 5.3.1 *Guidelines for Cleaning Glass Surfaces* on page 20 for detailed guidelines.



**If the heated grease collection reservoir is installed, monitor the liquid level throughout the day and empty unit as required.**

#### 5.1.3 Cleaning at the End of the Day

It is recommended to clean the rotisserie at the end of the business day, after all cooking has been completed.



**ENSURE YOU ARE WEARING INSULATED GLOVES AND AN APRON AT ALL TIMES WHEN WORKING WITH A HOT OVEN.**

#### 5.1.4 Description of Operation

The Auto Clean cycle consists of a succession of activities that are completely and automatically controlled by the rotisserie. The sequence is as follows:

- **OVEN COOLDOWN:** A period of time required for the rotisserie to reach a safe temperature for cleaning.
- **PREWASH:** A repetition of soaking in water and draining sequences
- **SOAP WASH:** Involves the repeated application of a cleaning agent followed by soaking and draining
- **FIRST RINSE:** A rinsing cycle.
- **POWER RINSE:** Another, different type of rinsing cycle.
- **FINAL RINSE:** A series of rinsing cycles involving water collection followed by draining.

### 5.1.5 Auto Clean Operation

It is recommended to run the Auto Clean cycle at the end of the business day, after all cooking has been completed.



**ENSURE YOU ARE WEARING INSULATED GLOVES AND APRON AT ALL TIMES WHEN WORKING WITH THE HOT ROTISSERIE.**



**REFER TO YOUR COMPANY'S POLICY ON THE HANDLING OF HAZARDOUS MATERIALS WHEN REPLACING THE DEGREASER BOTTLE; FOR MORE INFORMATION, CONSULT THE DEGREASER'S MATERIAL SAFETY DATA SHEET.**

1. Verify that there is sufficient degreaser in the bottle as shown in Figure 5-1.
2. Open the door, and open the manual drain valve handle as shown in Figure 5-2.
3. Remove any large pieces that are left on the bottom of the water pan.



**DO NOT PUSH SOLID DEBRIS INTO THE DRAINS.**

4. Ensure that an empty grease shuttle or a bucket is positioned under each oven's drain.
5. Drain the water pan by turning the manual drain valve handle to "OPEN".
6. Remove debris and add water to help float away remaining residues in the water pan.
7. Spray a Hardt-approved oven cleaner on all major surfaces (drive plate, spit support, shaft, water pan, and side walls as shown in Figure 6 3) and let it settle for 15 minutes.
8. Close the manual drain valve handle.
9. Open the water inlet valve handle to add water to the water pan. Make sure the water is draining freely and not rising or overflowing out the oven door.
10. Close the water inlet valve handle. Open the manual drain valve handle and drain the water pan completely.
11. Open the water inlet valve handle to add a small amount of water to the water pan. Using a towel wipe the water pan clean removing all particles.
12. Close the water inlet valve handle.
13. Drain the water pan completely.
14. Close the manual drain valve. The manual drain valve handle must be closed for the Auto clean to operate.
15. Close the oven door and press the 'CLEAN' button and then the 'ENTER' button. Read the display. If the Auto Clean has begun it will read either, "CHECKING OVEN TEMPERATURE", "CLEAN COOLDOWN" or "PREWASH".

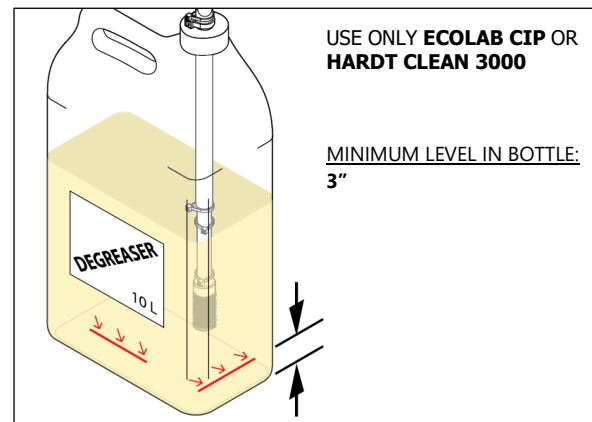

Figure 5-1

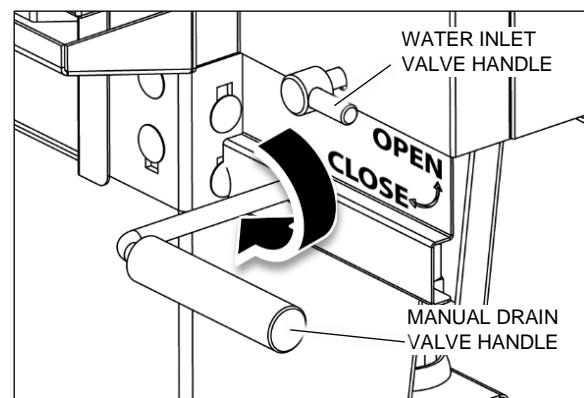

Figure 5-2

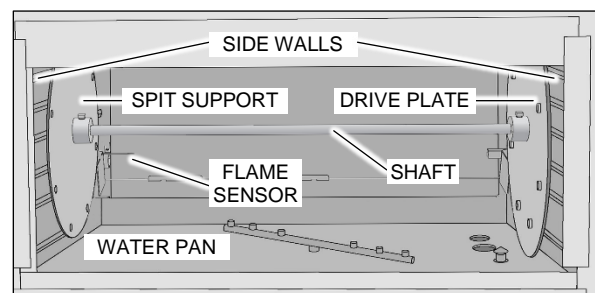

Figure 5-3



If the display reads, “CLEAN COOLDOWN” the Auto Clean will not start immediately as the cooking cavity is too hot. **DO NOT** open the door to cool the rotisserie! It must cool on its own with the door closed so the degreaser works properly. The Auto Clean will start on its own when the rotisserie has properly cooled.



For rotisseries equipped with the optional sensors – If the degreaser is low, an alarm will sound and the display will show: “REFILL DEGREASER BOTTLE // PRESS CLEAN”. Replace the degreaser bottle and start again.

If the display shows: “CLOSE DRAIN VALVE // PRESS CLEAN”, the Drain Valve is not fully closed. Close it and start again.

16. Clean the outside of the rotisserie.
17. Gently scrub with a Hardt approved non-abrasive brush (if required). Refer to section 5.3.2 *Guidelines for Cleaning Metal Surfaces on page 20* for detailed guidelines.
18. Gently rinse off all the oven cleaner with water.
19. Fill the water pan then drain it.
20. Verify that the rotisserie is clean.
21. If required, gently rinse the entire oven again.
22. Clean the front of the rotisserie with a mild soap and water solution.

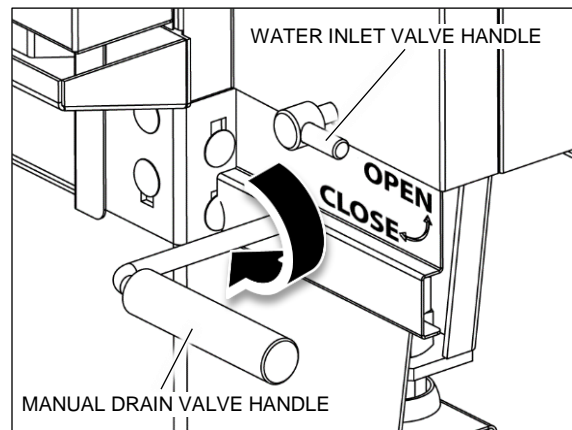

Figure 5-4

### 5.1.6 Auto Clean Effectiveness Evaluation

It is important to consider the condition of the rotisserie after the Auto Clean cycle is finished to verify that the cleaning operations are functioning correctly. The following images illustrate three states of cleanliness and their related interpretation.



**COOKING IN AN OVEN WITH RESIDUE BUILD-UP CAN CAUSE A FIRE.**

Figure 5-5: *Dirty Cavity*

The image shows a cavity that has NOT been cleaned sufficiently to cook in. This may be due to the cleaning procedures not being followed on a consistent basis or the Auto Clean system having not functioning properly for an extended period of time.



Figure 5-5

Figure 5-6: *Mostly Clean Cavity*

It will be necessary to clean the rotisserie by hand using regular oven cleaner (in a spray bottle) and a scrub pad or scraper to remove the build-up of carbon prior to running the Auto Clean cycle.

The Auto Clean function will only clean the grease from 1 day worth of cooking. It may take a few days of Auto Clean and hand scraping to get the rotisserie back to the point where following the correct procedures will produce a clean rotisserie in the morning.

If the rotisserie cavity looks like what is shown in Figure 5-6, remove the residual flakes with a scrub pad PRIOR to cooking.

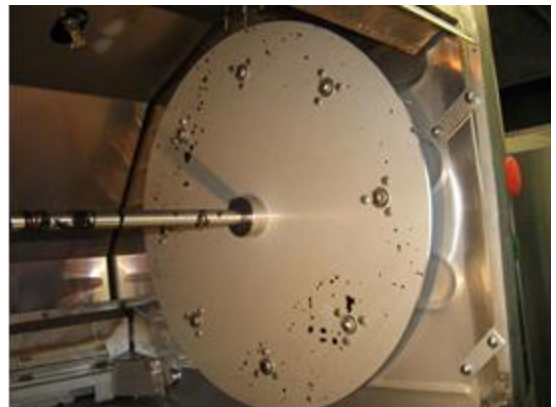

Figure 5-6

Figure 5-7: *Sufficiently Clean Cavity*

The image shown in Figure 5-7 shows a rotisserie cavity that is sufficiently clean and in which cooking may be performed.



Figure 5-7

## 5.2 Weekly Inspection

Thoroughly inspect the venting components supplied with the rotisserie for signs of damage (dents, perforations, etc.). Replace with certified Hardt components if required. Ensure that the electrical cord, water and gas lines are free from damage and kinks.

## 5.3 Material Cleaning Guidelines

### 5.3.1 Guidelines for Cleaning Glass Surfaces

- Wipe off residues with a soft cloth or a paper towel.
- Remove baked-on residues using a wooden or plastic scraper. Avoid using a metal scraper as it may scratch the glass.
- Surfaces may be cleaned using a soft cloth with mild soap and water. Alternately, a glass cleaning spray with paper towels may be used.
- Avoid scratching the surface of the glass.



**Do not use abrasive scouring powder or abrasive cleansers on the glass door, the lamp's glass shield and the control panel.**

**Do not use metallic scouring pads.**

**Do not use metal scrapers.**

**Avoid putting cold water or a cold damp cloth onto the hot glass as this may cause the glass to crack and shatter.**

### 5.3.2 Guidelines for Cleaning Metal Surfaces

- Wipe up spills and residues with a cloth or paper towel.
- Remove baked-on residues using a wooden or plastic scraper. Avoid using a metal scraper as it may scratch the metal finish of the rotisserie.
- Surfaces may be cleaned using a soft cloth with mild soap and water. Alternately, a spray-on degreaser may also be used but only on stainless steel surfaces following the handling procedure outlined on the product label. Do not apply degreasers or other harsh chemicals to painted surfaces as this may permanently affect the look and performance of the finish.
- The look of stainless steel surfaces can be improved by using stainless steel polishing creams. Follow the instructions on the packaging of the polishing product being used.
- Avoid scratching or marring metal surfaces.
- For stubborn build up on the interior stainless steel surfaces of the oven (including around the door's opening), bristle brushes or mild scouring pads can be used. Refer to the daily cleaning laminates for details.



**Do not use abrasive scouring powder or abrasive cleansers.**

**Do not use metallic scouring pads.**

**Do not use metal scrapers.**

**Do not use corrosive cleaning agents.**

## 6. Troubleshooting



**SERVICE/REPAIRS SHOULD ONLY BE PERFORMED BY TRAINED PERSONNEL. DISCONNECT POWER TO THE ROTISSERIE BEFORE ANY MAINTENANCE, SERVICE OR CLEANING IS PERFORMED.**

**ROTISSERIES EQUIPPED WITH CASTERS ARE SECURED IN PLACE USING A RESTRAINING CABLE LOCATED ON THE RIGHT REAR UNDERSIDE OF THE ROTISSERIE. THIS CABLE MUST BE DISCONNECTED PRIOR TO REMOVING THE ROTISSERIE AND CAUTION MUST BE TAKEN TO ENSURE IT IS CONNECTED ONCE THE ROTISSERIE HAS BEEN RETURNED TO ITS ORIGINAL POSITION.**

**THE ROTISSERIE IS HOT WHEN OPERATING. EXERCISE CAUTION WHEN WORKING NEAR THE HOT ROTISSERIE.**

**WEAR APPROPRIATE PROTECTIVE CLOTHING BEFORE ANY MAINTENANCE, SERVICE OR CLEANING IS PERFORMED.**

### 6.1 Rotisserie Does Not Operate

#### **SYMPTOM:**

The rotisserie does not operate when the red main ON/OFF is pulled out (i.e. drive does not turn, and oven light does not illuminate).

#### **SOLUTION:**

- Check the rotisserie electrical power: If the rotisserie's lights are off, check the circuit breaker on the back of the rotisserie as shown in Figure 6-1. If the circuit breaker is 'OFF' (tripped), return to 'ON'.
- Verify that the door is fully closed. The door switch disables the ignition system.
- If this circuit breaker is 'ON', ensure that the power cord is plugged into the wall and that there is power coming from the socket. If power is available and the rotisserie still does not operate, contact your local authorized service partner.

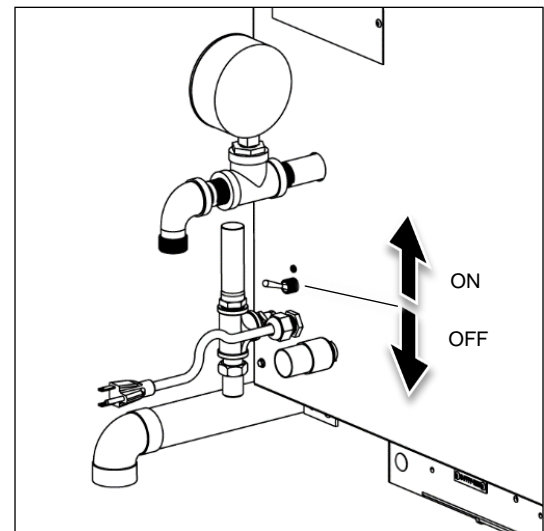

Figure 6-1

## 6.2 Safety Lockout

### SYMPTOM:

If the preheat (or cooking) cycle is initiated, the drive drum will rotate and the igniter will attempt to light the burner. If there is no flame after six minutes, the rotisserie will go into Safety Lockout mode, an alarm will sound and the red SLO (Safety lockout) alarm lamp on the control panel will illuminate.

Possible causes include: the gas supply is shut off, the flame sensor is not sensing flame or there is a component failure.

### SOLUTION:

- Turn the rotisserie off by pushing in the red main ON/OFF switch.
- Verify that the gas supply to the rotisserie and the main gas valve are both open. Try starting the rotisserie again by pulling the red main ON/OFF switch out and start a preheat cycle by pressing PREHEAT  on the control panel.

If the rotisserie goes into 'safety lockout' again. Turn the rotisserie OFF.

- Carefully remove the burner cover taking care not to scratch the inner surfaces of the rotisserie.
- Using a soft towel, gently wipe the top of the burner and carefully clean the flame sensor. Replace the cover.
- Try starting the rotisserie again. Pull out the red main ON / OFF switch and start a preheat cycle by pressing PREHEAT  on the control panel.
- If the rotisserie goes into safety lockout again, there is most likely a component failure. Turn the rotisserie OFF and contact your local authorized Hardt service provider.

## 6.3 Replacing the Halogen Light Bulb

1. Turn the rotisserie OFF by pushing in the red main ON/OFF switch and disconnect the power cord from the wall receptacle.
2. Allow the rotisserie to sufficiently cool down.
3. Remove the halogen light access panel located on the left side of the rotisserie by loosening the thumb screws by hand (Figure 6-2).

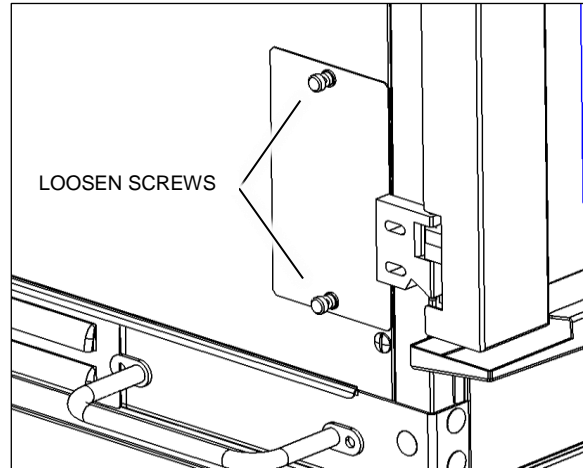

Figure 6-2

4. Loosen the wing nuts on the halogen light bulb support bracket in order to access the halogen light bulb (Figure 6-3).

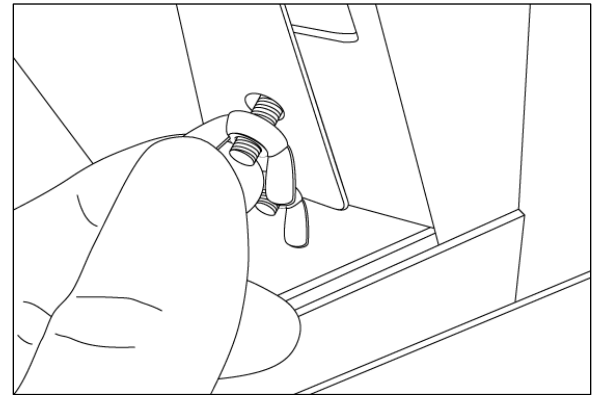

Figure 6-3

5. While wearing gloves, gently pull the old halogen light bulb out of its fixture (Figure 6-4).

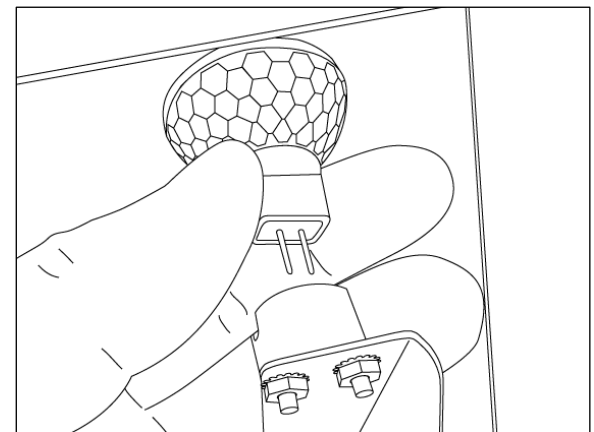

Figure 6-4



**Do not touch the replacement halogen light bulb with bare fingers or dirty gloves.**

6. Install a new halogen light bulb.
7. Position the halogen light bulb support bracket so that the light is oriented towards the center shaft of the rotisserie and hand-tighten the two wing nuts.
8. Plug the power cord back into the wall receptacle.
9. Turn the rotisserie ON by pulling out the red main ON/OFF switch.
10. Verify that the replaced halogen light bulb functions correctly. It is normal for the halogen light bulb to take about 6 seconds to illuminate after the red main ON/OFF switch has been pulled out. If not, repeat the first four steps of this procedure then make sure the halogen light bulb was correctly inserted in the socket.
11. Reinstall the halogen light access panel.
12. Turn the rotisserie ON by pulling out the red main ON/OFF switch and recheck.
13. If the problems persist, contact your local authorized service partner.

## 6.4 Numeric Temperature Display Mode

If it is required to have the temperature display mode switched from Fahrenheit to Celsius or vice versa, contact your local authorized service partner.