

# ***INTEK***®

## **SERVICE MANUAL / PARTS LIST**

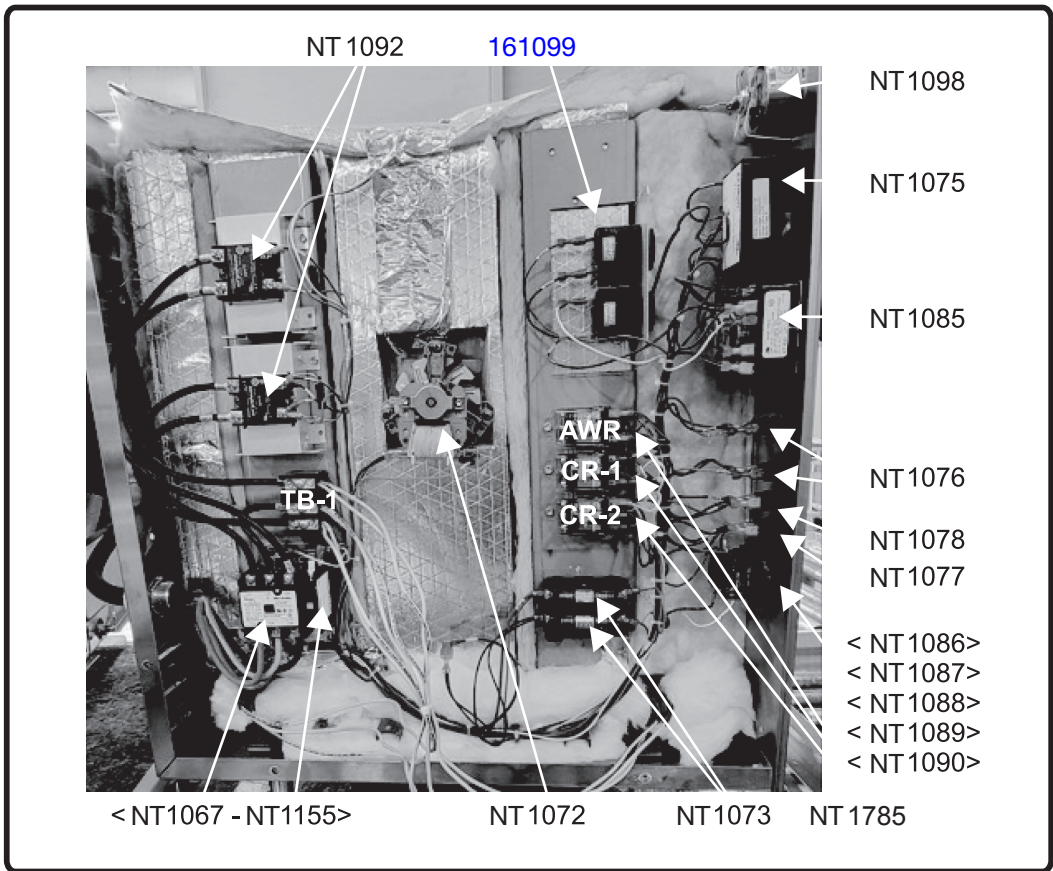
**ALL ELECTRIC MODELS and VOLTAGES**



888-994-7636 • 601-372-3903 • Fax 888-864-7636  
[unifiedbrands.net](http://unifiedbrands.net)

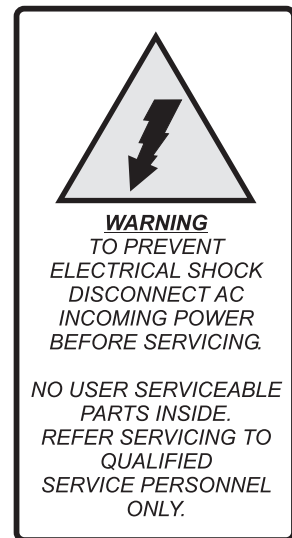
# TABLE OF CONTENTS

CONTROL SIDE COMPONENTS.....	3
ELEMENTS AND PLUMBING COMPONENTS.....	4
TROUBLESHOOTING GUIDE.....	5-6
WIRING DIAGRAM.....	7
REPLACEMENT PARTS.....	8
ELEMENT FIELD REPLACEMENT INSTRUCTIONS.....	9-26
THERMOMETER REPLACEMENT.....	27-29
ELEMENT AMP READING.....	30

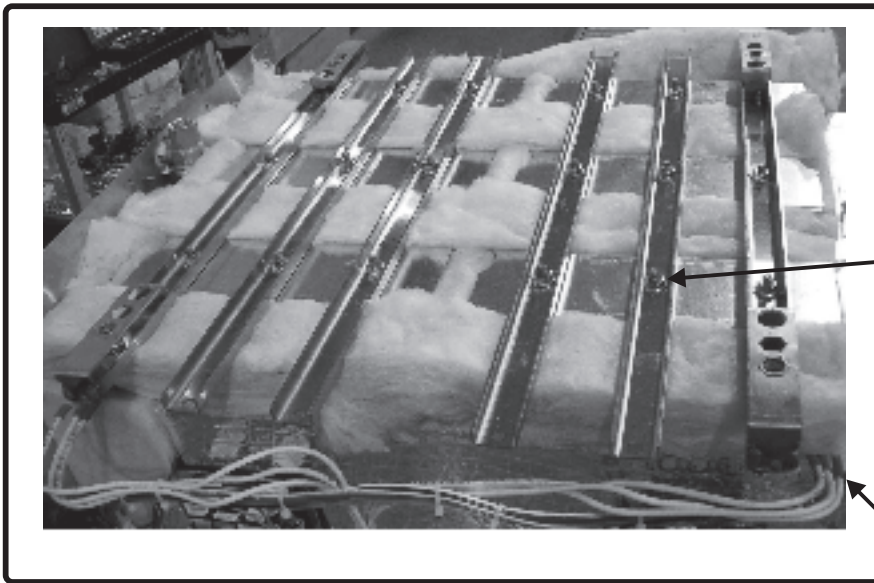


**FIGURE 1**  
**XS-208-12-3 (3 Phase Unit Shown)**

<u>INTEK P/N</u>	<u>Description</u>
161099	BEEPER, 120V-240V
NT1067	DP Contactor, Main Power
NT1785	Relay, 220V, Control
NT1072	Fan, Convection (Includes Blade Assy.)
NT1073	Fuse, 5 Amp
NT1075	Thermostat, Hold 100-212 Degrees
NT1076	Lamp, Red
NT1077	Lamp, Blue
NT1078	Lamp, Amber
NT1085	Timer, 60 Minute
NT1086	Operator, Switch, PB, On
NT1087	Operator, Switch, PB, Off
NT1088	Mounting Latch, On / Off Switches
NT1089	Contact, NC, Off Switch
NT1090	Contact, NO, On Switch
NT1092	Solid State Relay, 75A, AC Input
NT1098	Thermometer, Analog 100-220 Degrees
NT1155	Aux. Contact, DP Contactor



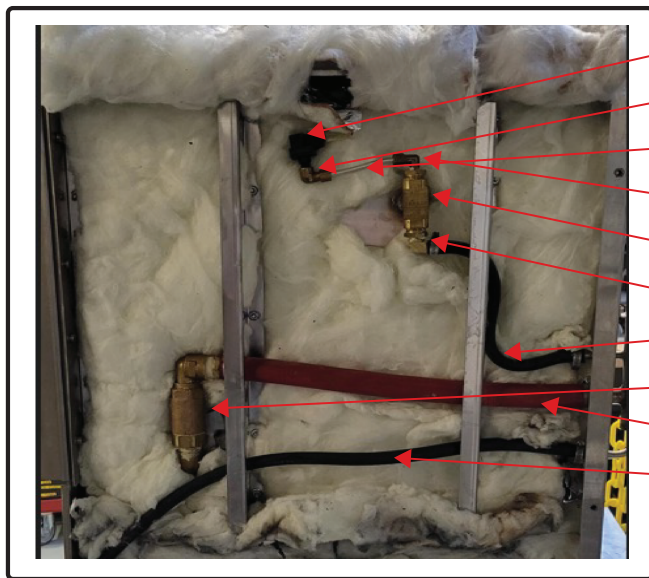
**REFER TO WIRING DIAGRAM FOR ADDITIONAL INFORMATION**



**FIGURE 2**

**IMPORTANT**  
 Apply Loc-Tite™  
 Removable-  
 ThreadLocker™  
**AND**  
 Torque Clamping  
 Nuts to 65in.lbs. /  
 5.5ft.lbs.

*Heater Is Located Under  
 Bracket / Clamp Assembly*



**FIGURE 3**

**WARNING**  
 TO PREVENT ELECTRICAL SHOCK DISCONNECT  
 AC INCOMING POWER BEFORE SERVICING.  
 NO USER SERVICEABLE PARTS INSIDE.  
 REFER SERVICING TO QUALIFIED  
 SERVICE PERSONNEL ONLY.

- NT1091
- 050500
- 161017
- 004584
- NT1200
- NT1555
- 161118
- 174322
- 161101
- 161100

**INTEK P/N Description**

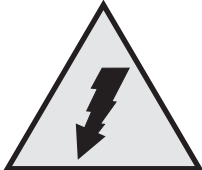
<b>NT1009</b>	Heater, 208V, 12kW
<b>NT1011</b>	Heater, 240V, 12kW
<b>NT1012</b>	Heater, 208V, 6.24kW
<b>NT1013</b>	Heater, 240V, 6.24kW
<b>NT1045</b>	Heater, 208V, 8.5kW
<b>NT1046</b>	Heater, 240V, 8.5kW
<b>NT1269</b>	Heater, 208V, 14.4kW
<b>NT1270</b>	Heater, 240V, 14.4kW
<b>NT1091</b>	Switch, Pressure, 1/8"NPT
<b>NT1797</b>	Heater, 208V, 14.4kW (new ver.)
<b>NT1798</b>	Heater, 240V, 14.4kW (new ver.)
<b>174322</b>	Check Valve Assembly
<b>161017</b>	1/4" X 4" Long Aluminum Tube
<b>161100</b>	Hose 5/16" 28" Long EPDM
<b>161101</b>	Hose 3/4" 16.75" Long EPDM
<b>161118</b>	Hose 5/16" 12" Long EPDM
<b>NT1200</b>	Brass Tee- 1/2 FP
<b>NT1555</b>	Brass Elbow Fitting- Hose Barb X 90 Degree Male- Blockstyle
<b>Z004584</b>	Fitting Compression 90 1/8NPT X 1/4CC
<b>Z050500</b>	Elbow Female 90 Deg

**PARTS NOT SHOWN**

<b>NT1079</b>	Thermostat, Bi-metal, 325F
<b>NT1080</b>	Thermostat, Bi-metal, 410F
<b>125907</b>	Gasket, Door HY-5 Silicone

**REFER TO WIRING DIAGRAM FOR ADDITIONAL INFORMATION**

# TROUBLESHOOTING GUIDE

	<p><b>WARNING</b></p> <p>TO PREVENT ELECTRICAL SHOCK DISCONNECT AC INCOMING POWER BEFORE SERVICING.</p> <p>NO USER SERVICEABLE PARTS INSIDE. REFER SERVICING TO QUALIFIED SERVICE PERSONNEL ONLY.</p>
---	---

SYMPTOM	POSSIBLE CAUSE
<p>No Lights When ON Is Pressed</p>	<p>Facility Main Breaker, Unit Ran Dry- No Water In Chamber, F1/F2 Fuse, Hi-Limit (OT-1), MC, CR-1 or N.O. Contact- ON Pushbutton</p>
<p>Unit Turns ON When "ON" Pushed- Turns OFF When Released</p>	<p>Auxiliary Contact on MC, N.C. Contact- OFF Pushbutton</p>
<p>"Add Water" Light On</p>	<p>Not Enough Water In Chamber, Build-Up (Lime) On Chamber Bottom, OT-2/OT-3 or AWR.</p>
<p>Unit Won't Heat Up: 1) w/ Steam Out Exhaust 2) w/o Steam Out Exhaust</p>	<p>PS-1, SSR-1/SSR-2, CR-2 Not Working In Cook Mode Steam Orifice Is Blocked</p>
<p>Heat Stays On (Light Stays On)</p>	<p>Normal When Door Open, PS-1, SSR-1/SSR-2 (If Door Is Leaking Steam- Adjust First)</p>
<p>Heat Stays On (Light Cycles)</p>	<p>SSR-1/SSR-2</p>

## OPERATING SUMMARY

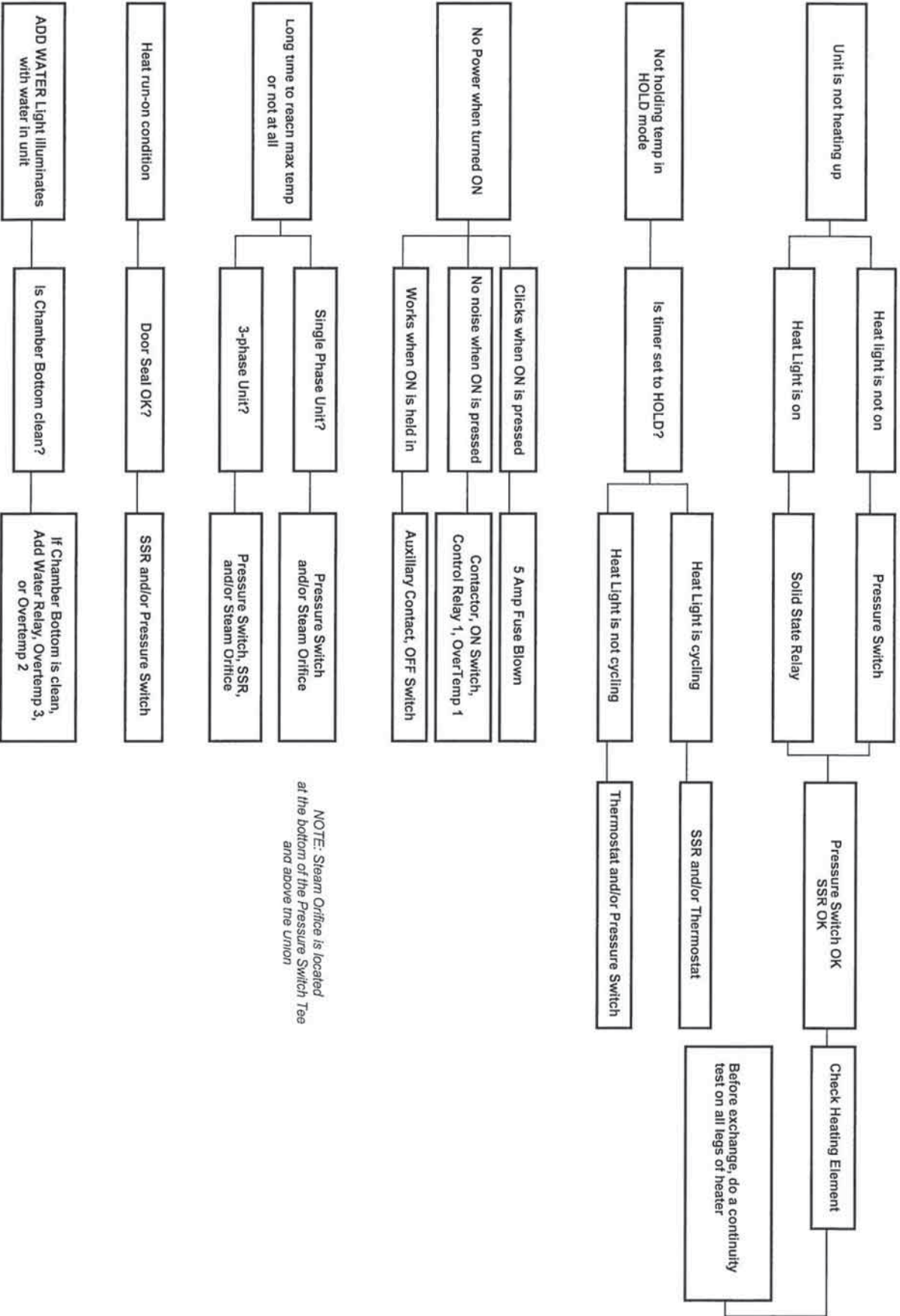
When the timer is at the HOLD position, heat is controlled by the HOLD Thermostat. When the timer is at any other position, heat is directly controlled by PS-1 (pressure switch). Note: Both COOK and HOLD Mode heat outputs are directed through PS-1.

It is normal for the Heat Indicator Light to cycle ON and OFF.

The Convection Fan (CFM) is only on during the cooking cycle.

**REFER TO WIRING DIAGRAM FOR ADDITIONAL INFORMATION**

# TROUBLESHOOTING GUIDE



NOTE: Steam Orifice is located at the bottom of the Pressure Switch Tee and above the Union

**WARNING**

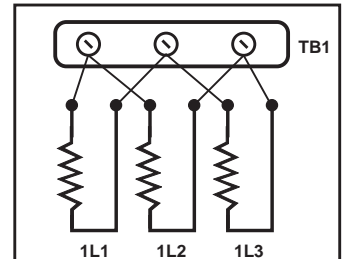
REFER SERVICING TO QUALIFIED PERSONNEL ONLY. DISCONNECT AC INCOMING POWER BEFORE SERVICING.

**IMPORTANT**  
DO NOT CONNECT POWER TO L3 ON SINGLE PHASE UNITS

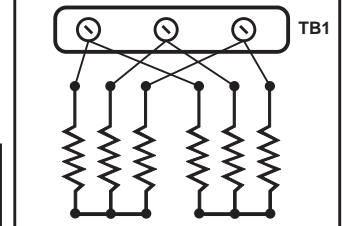
THIS LEG REMOVED ON SINGLE PHASE UNITS

TO TB1

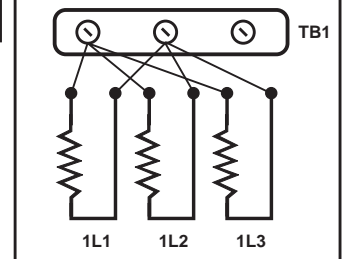
HEATING ELEMENT CONFIGURATION  
SELECT MODEL BELOW



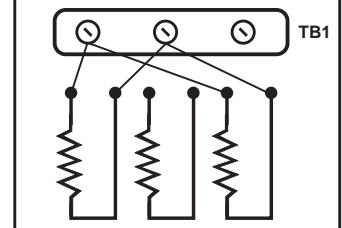
MODELS: XS208-8-3, XS240-8-3  
XS208-12-3, XS240-12-3  
XS480-12-3  
< S/N 5500  
XS208-14-3, XS240-14-3



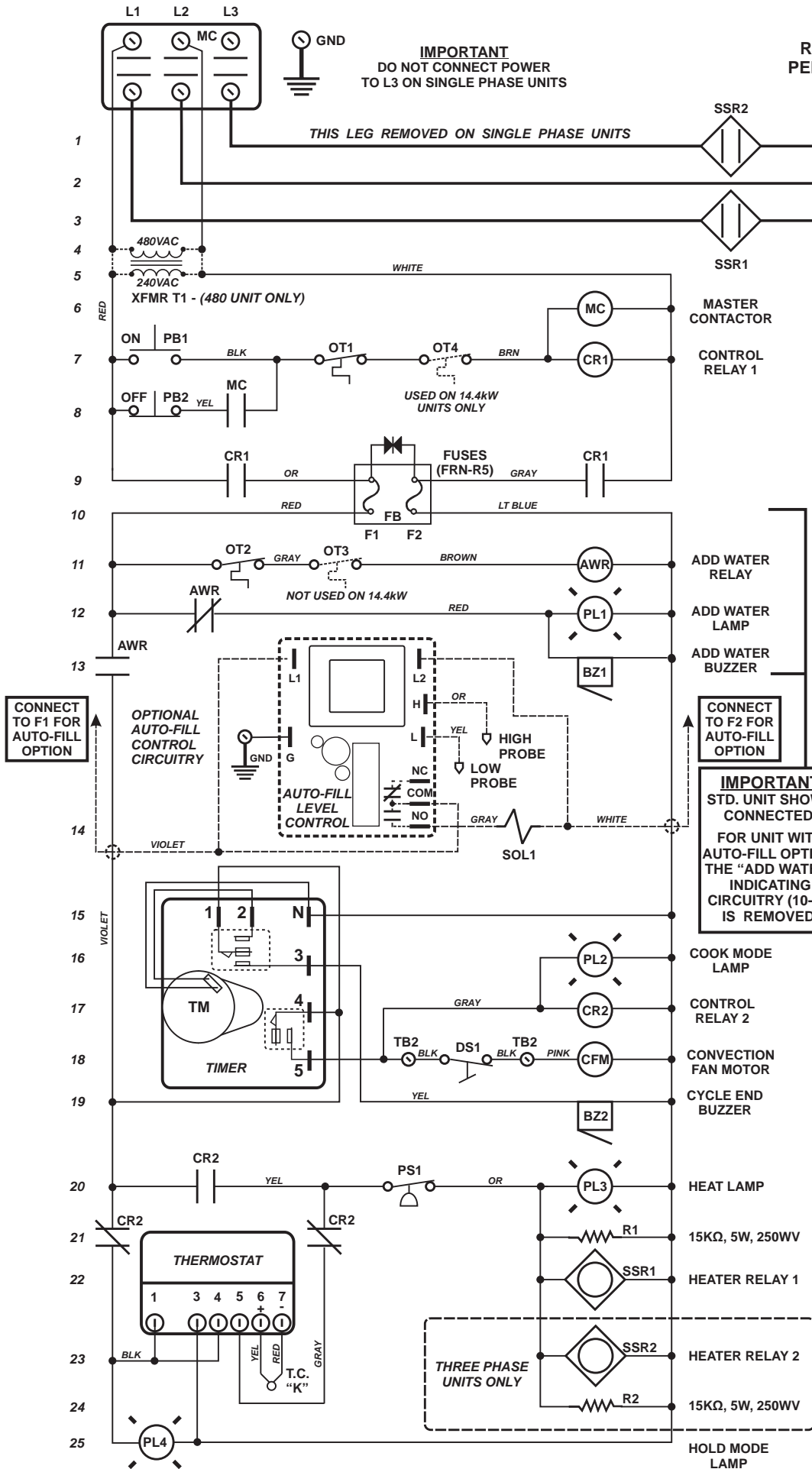
1L1,1L2,1L3 1L1,1L2,1L3  
MODELS: > S/N 5500  
XS208-14-3, XS240-14-3



MODELS: XS208-6-1  
XS240-6-1

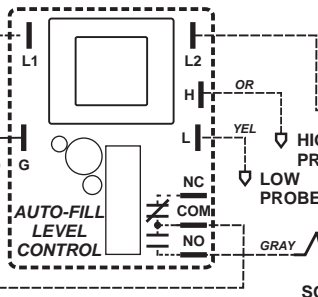


MODELS: XS208-8-1  
XS240-8-1



CONNECT TO F1 FOR AUTO-FILL OPTION

OPTIONAL AUTO-FILL CONTROL CIRCUITRY



CONNECT TO F2 FOR AUTO-FILL OPTION

**IMPORTANT**  
STD. UNIT SHOWN CONNECTED.  
FOR UNIT WITH AUTO-FILL OPTION, THE "ADD WATER" INDICATING CIRCUITRY (10-13) IS REMOVED.

## REPLACEMENT PARTS LIST

<u>Part No.</u>	<u>Description</u>	<u>Part No.</u>	<u>Description</u>
NT1009	Heater, 208V, 12kW	NT1096	Thermocouple
NT1011	Heater, 240V, 12kW	NT1037	Shelf Bracket, Stand
NT1012	Heater, 208V, 6.24kW	NT1027	Pan Bracket- Steamer Bottom
NT1013	Heater, 240V, 6.24kW	170908	HARNESS, INTEK ELECTRIC, MANUAL FILL
NT1045	Heater, 208V, 8.5kW	NT1117	Steamer Foot, flanged
NT1046	Heater, 240V, 8.5kW	NT1104	Screw, 10-24 x 1/2 SS
NT1269	Heater, 208V, 14.4kW	NT1217	Nutsert
NT1270	Heater, 240V, 14.4kW	NT1202	Brass Reducer, 1/2 x 1/8
NT1797	Heater, 208V, 14.4kW (new ver.)	161017	1/4" X 4" LONG ALUMINUM TUBE
NT1798	Heater, 240V, 14.4kW (new ver.)	161100	HOSE 5/16" 28" LONG EPDM
161099	BEEPER, 120V-240V	161101	HOSE 3/4" 16.75" LONG EPDM
NT1067	DP Contactor, Main Power	161118	HOSE 5/16" 12" LONG EPDM
NT1070	Relay, 220V, Control	NT1200	BRASS TEE- 1/2 FP
NT1072	Fan, Convection (Includes Blade Assy.)	NT1555	BRASS ELBOW FITTING- HOSE BARB X 90
NT1073	Fuse, 5 Amp		DEGREE MALE- BLOCKSTYLE
NT1075	Thermostat, Hold 100-212 Degrees	Z004584	FITTING COMPRESSION 90 1/8NPT X 1/4CC
NT1076	Lamp, Red	Z050500	ELBOW FEMALE 90 DEG
NT1077	Lamp, Blue		
NT1078	Lamp, Amber		
NT1079	Thermostat, Bi-Metal, 325°F		
NT1080	Thermostat, Bi-Metal 410°F		
NT1083	Plug, Angle 250V 3PH		
NT1085	Timer, 60 Minute		
NT1086	Operator, Switch, PB, On		
NT1087	Operator, Switch, PB, Off		
NT1088	Mounting Latch, On/Off Switches		
NT1089	Contact, NC, Off Switch		
NT1090	Contact, NO, On Switch		
NT1091	Switch, Pressure, 1/8" NPT		
NT1092	Solid State Relay, 75A, AC Input		
NT1093	Terminal block, 3-pos.		
NT1098	Thermometer, Analog 100-220 Degrees		
NT1155	Aux. Contact, DP Contactor		
125907	GASKET, DOOR HY-5 SILICONE		
NT1115	Hinge, one pair		
NT1144	Magnetic Door Latch		
NT1175	Stand Caster, 5" Locking		
NT1176	Stand Caster, 5" Non-locking		
NT1178	Knob		
NT1335	Nutplate		
NT1127	Drain Valve		
NT1022	Shell/Top		
NT1023	Right Side, Shell		
NT1151	Left Side Shell, Louvered		
161061	Door Assembly, Intek		
NT1137	Auto Fill Control Board with Probes		
NT1028	Control Panel Overlay		
174322	Check Valve Assembly		
NT1116	Heat Sink		
NT1132	3/4 Inch Hose		
NT1001	Galvanized Bottom Plate		
NT1003	Heater Plate, Aluminum		
NT1120	Insulation, Chamber bottom		
NT1135	Lens, Thermometer		
NT1537	Inner Door Panel Assembly		

## Extreme Steam Element Field Replacement Instructions



### Please Read and Follow the Instruction Below

- Safely remove all power connections, drain lines, and fill lines (if applicable). A stacked unit must be removed from its location (top or bottom) in order to change the element.
- Disconnect the element wires connected to the terminal block.
- Due to the location of the element and the limited space available, you must turn the unit upside down.
- Remove the two side panels.

## Removing the Extreme Steam Heating Element



- Step 1:** Turn the unit upside down and remove the legs using a Crescent Wrench as shown above



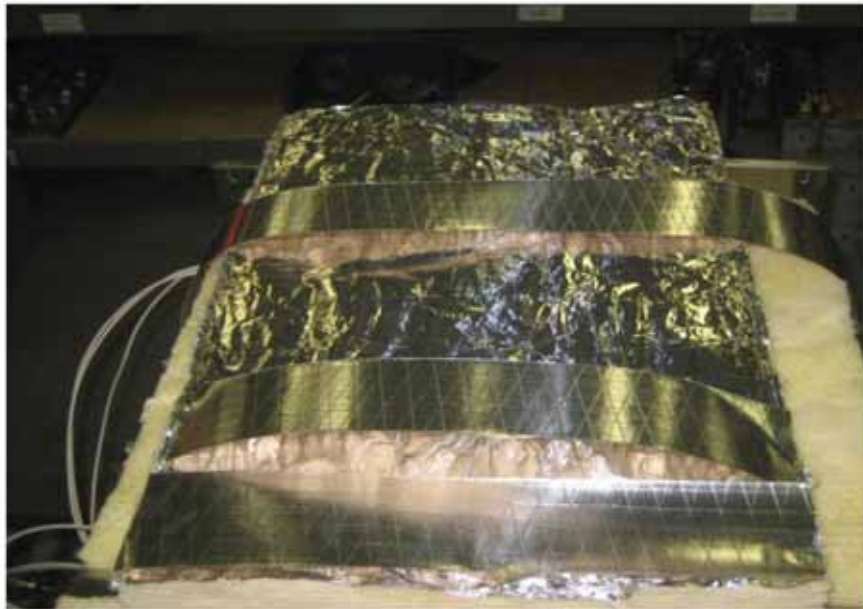
**Step 2:** Remove the drain cover **Part # NT1048** and two screws **Part # NT1105**



**Step 3:** Remove the (5) drip rails Screws **Part# NT 1104**



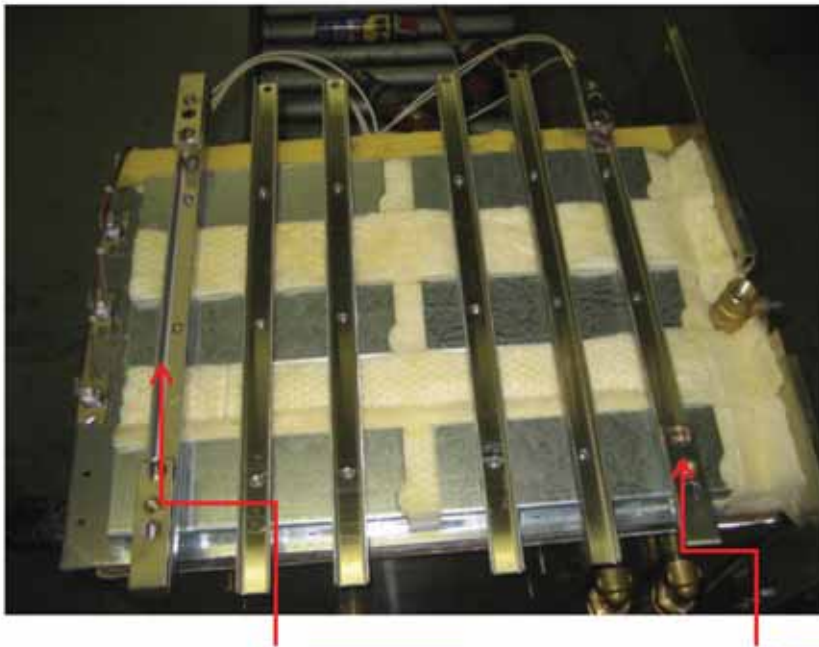
**Step 4:** Remove the bottom and back panel as seen above



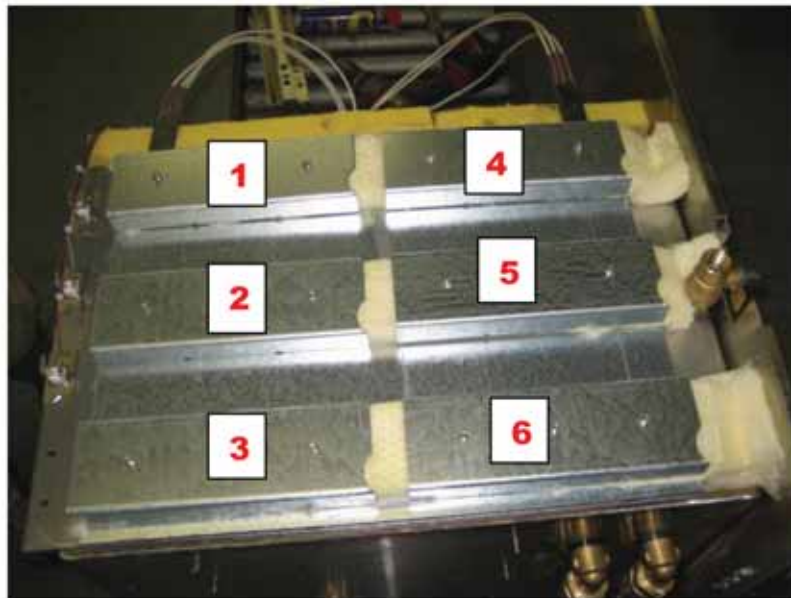
**Step 5:** Remove insulation **Part #1162** shown above



**Step 6:** Remove sheet insulation **Part# 1120**



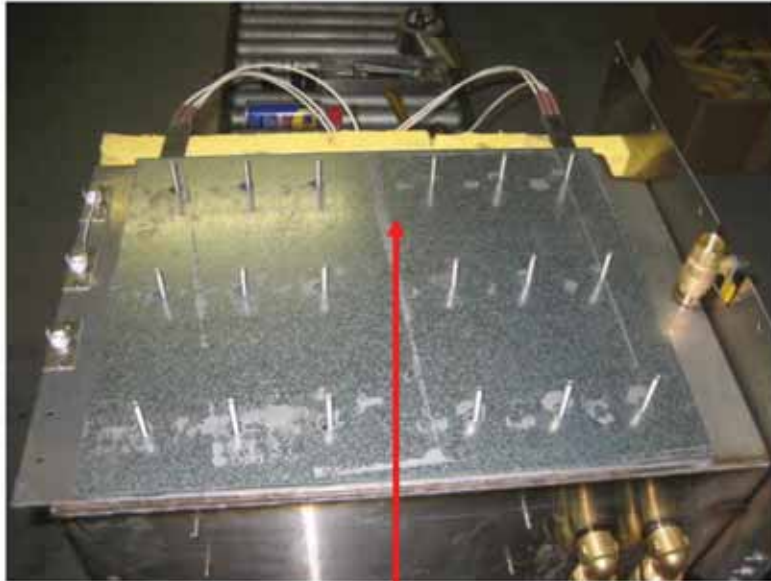
**Step 7:** Remove the U-Brackets and note **tall bracket** is in the rear and the **short bracket** in the front



**Step 8:** Remove the (6) u-channels **Part# NT1014** as seen above

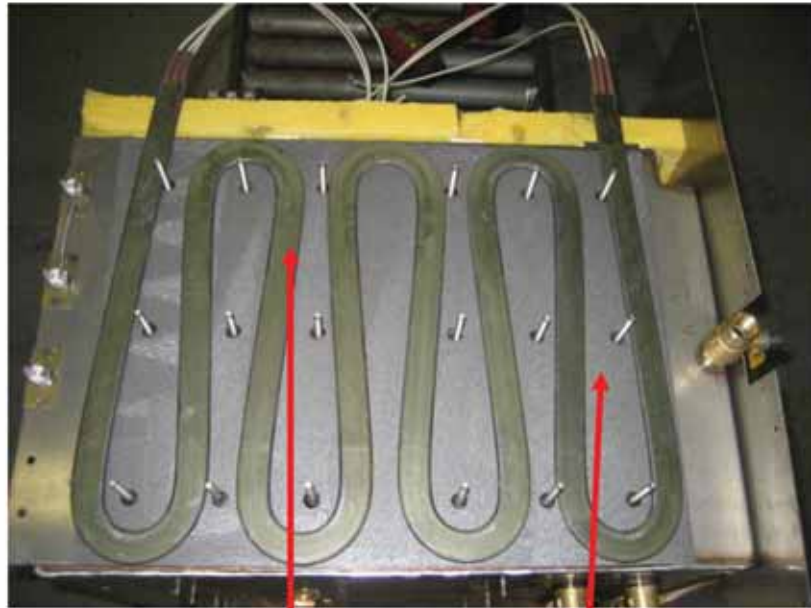


**Step 9:** Remove Insulation **Part# NT1120** from bottom of unit



**Step 10:**

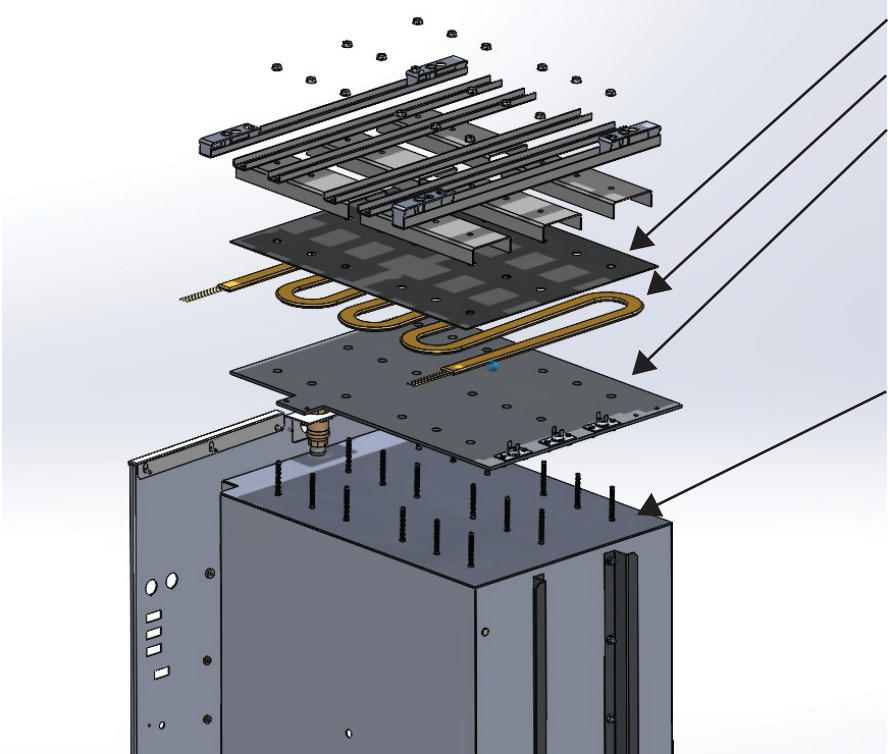
Remove bottom **Galvanized Heater Plate** Part # 1001



**Step 11:**

Remove the **Element** and the **First Heater Plate**

# Installing the Extreme Steam Heating Element

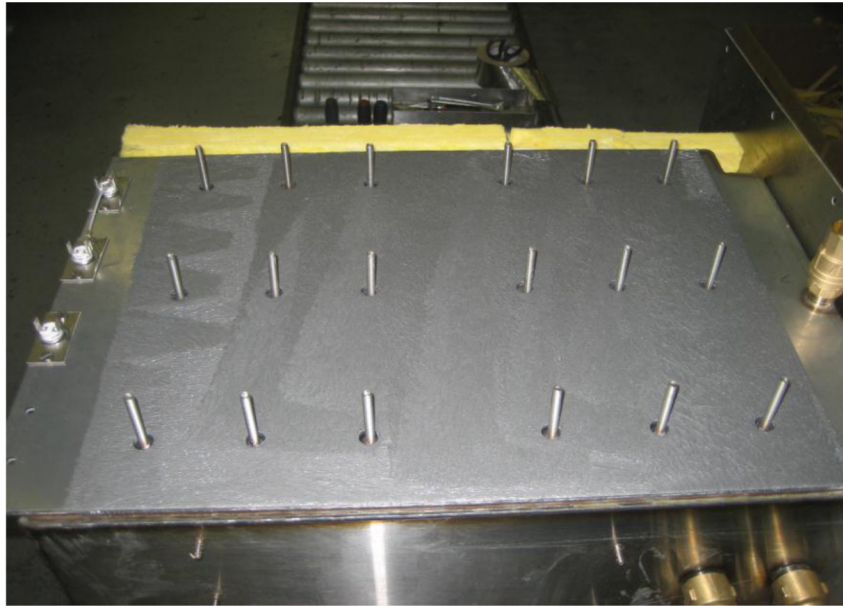


NT1001  
ELEMENT

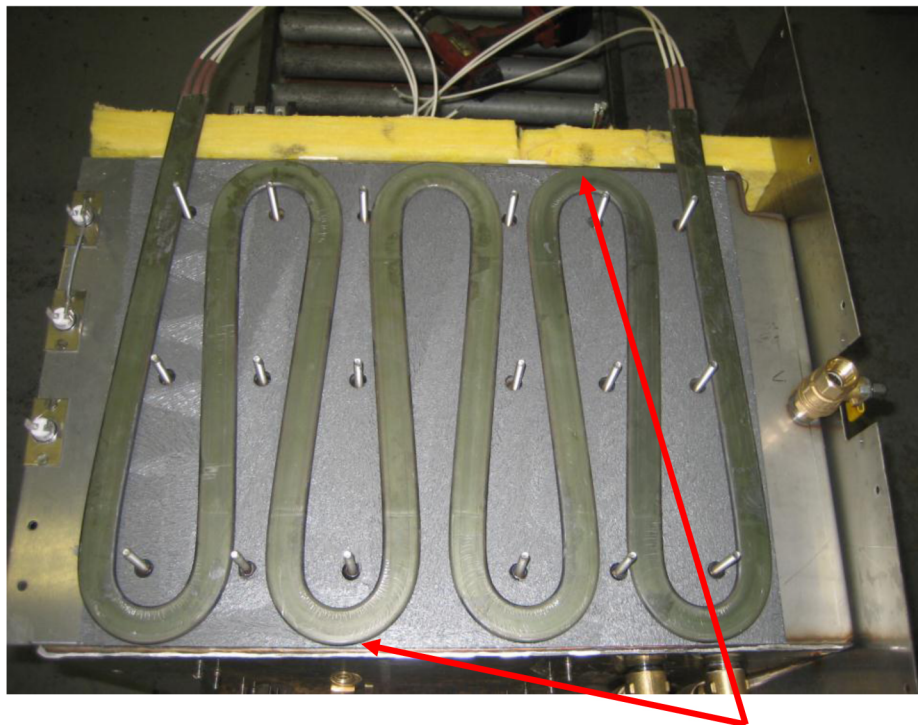
NT1003  
APPLY (PART NUMBER  
143409) THERMAL  
TRANSFER COMPOUND  
INBETWEEN NT1003  
AND THE ELEMENT AND  
NT1001

APPLY (PART NUMBER  
143409) THERMAL  
TRANSFER COMPOUND  
BETWEEN NT1003 AND  
THE BOTTOM OF THE  
STEAMER CAVITY.  
ASSEMBLY TO BE  
COMPLETED WITHIN 30  
MINUTES OF APPLYING  
AND ALLOW 2 HOURS  
MINIMUM TO CURE. DO  
NOT ALLOW  
COMPOUND TO  
CONTACT THERMO-  
STATS. EXCESS TO BE  
REMOVED BEFORE IT  
CURES.

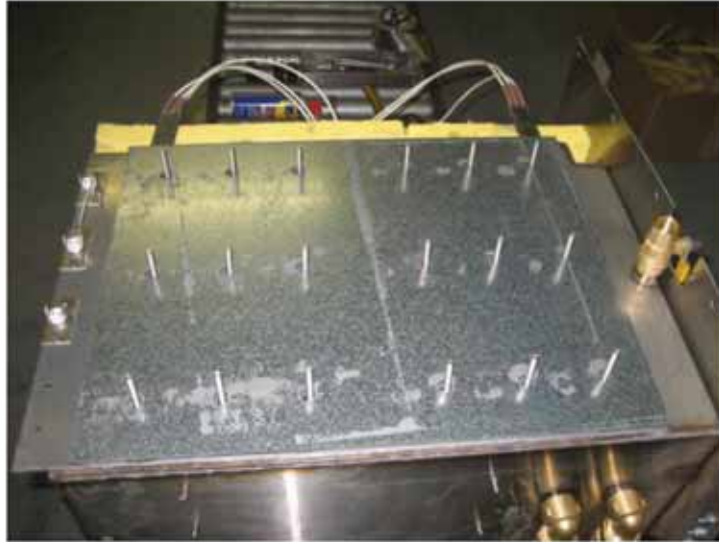
**Step 1:** The heater plate Part #NT1003 needs to be coated on one side with Thermal Transfer compound using a roller brush.



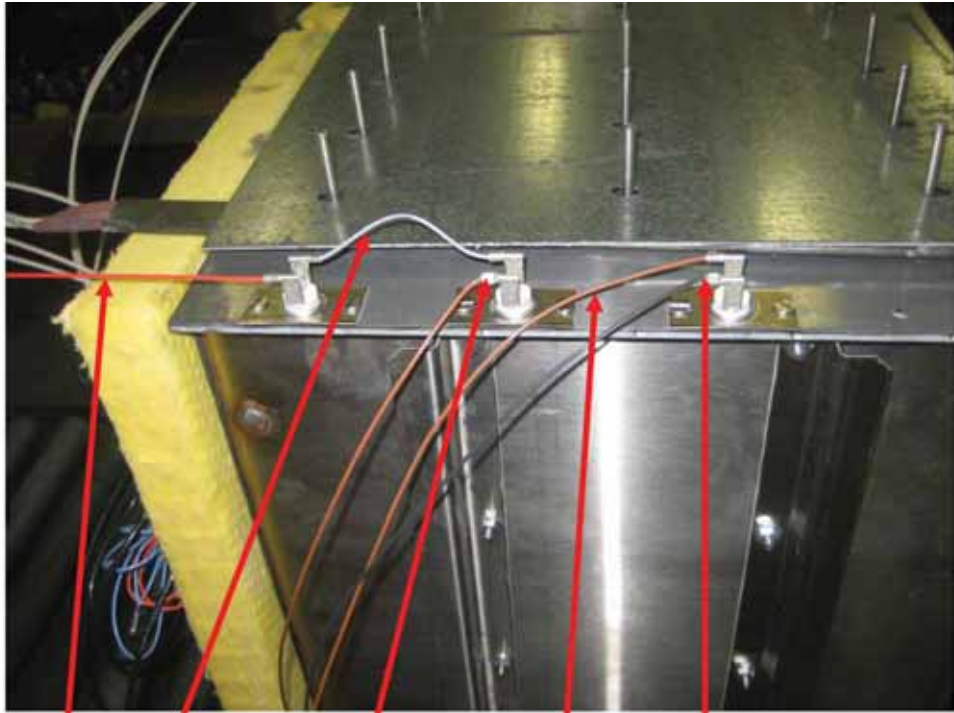
**Step 2:** Turn the unit upside down and install the first Heater Plate Part# NT1003



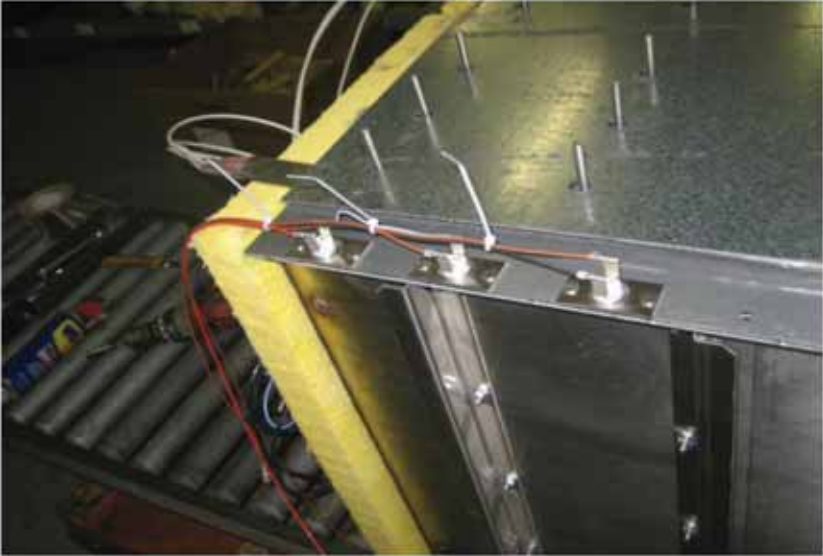
**Step 3:** Slightly bend the element to improve the fit, making sure the **edge of the turns** are not hanging over the heater plate and the element isn't touching the studs at any stud locations



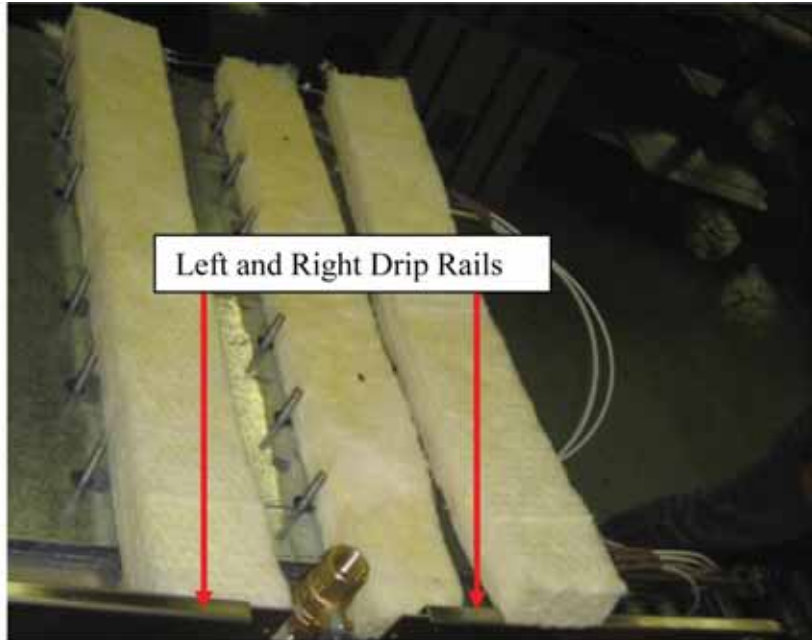
**Step 4:** Install the galvanized bottom heater plate **Part # NT1001**



**Step 5:** Install the **red, jumper, long brown, short brown** and **black** wires as seen above



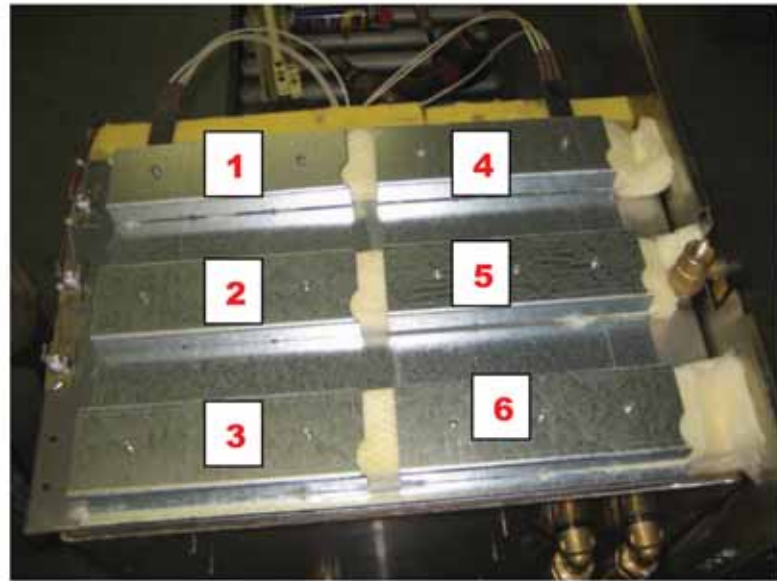
**Step 6:** Zip tie as seen above



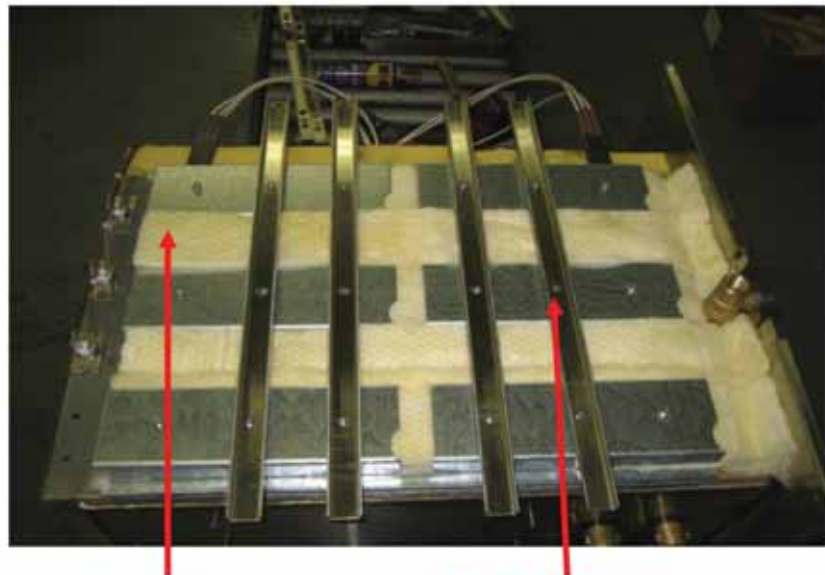
**Step 7:** Install the left drip rail **Part# NT1051** and the right drip rail **Part# NT1052**.  
Set in place but do not attach



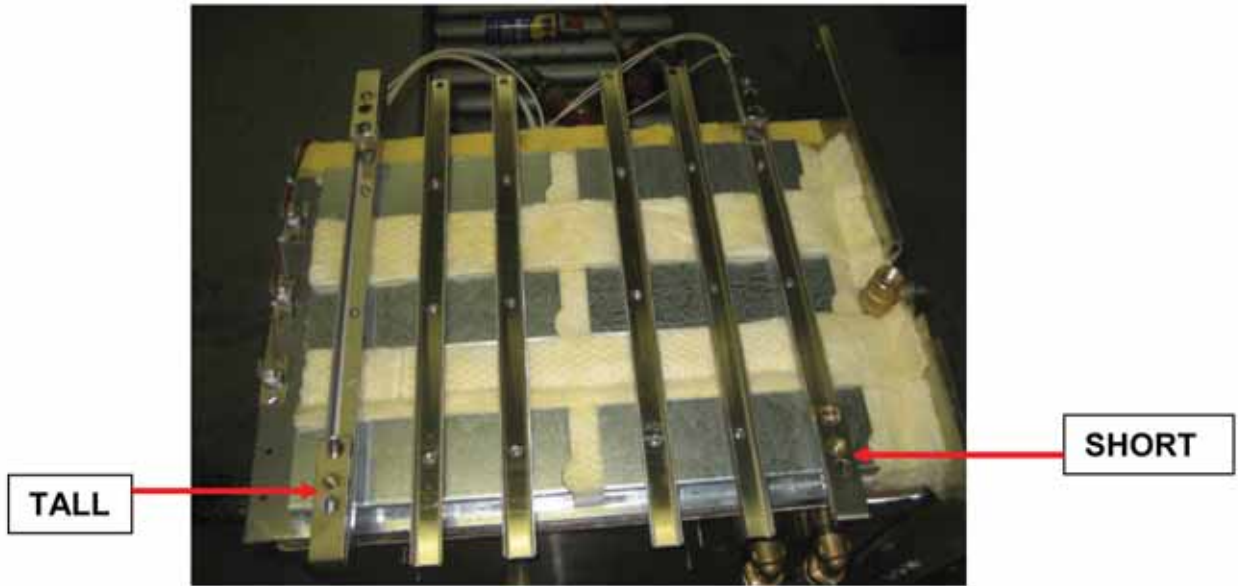
**Step 8:** Place the insulation **Part # NT1120** as seen on the bottom of the unit



**Step 9:** Insert (6) u-channels **Part# NT1014** as seen above



**Step 10:** Add **insulation** and install (4) **Part# NT1016** as seen



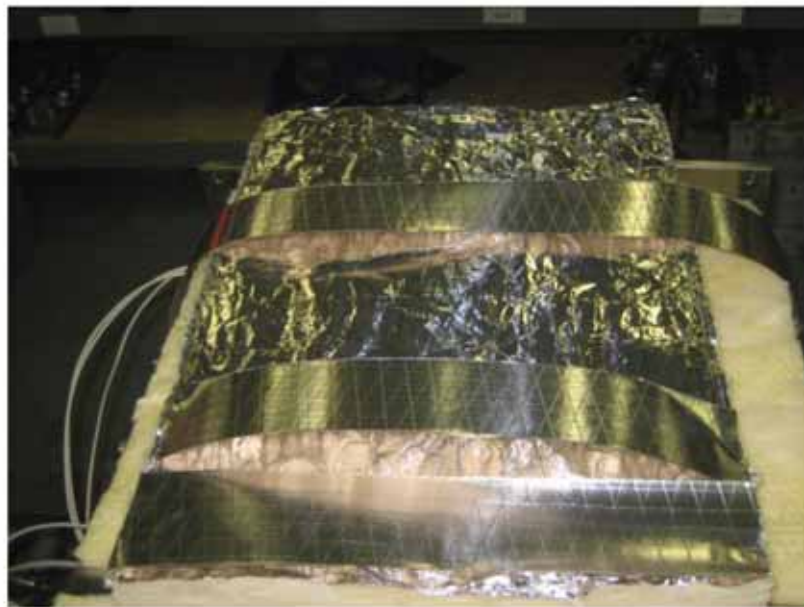
**Step 11:** Install the short and tall U-Brackets towards the front of the unit



**Step 12:** Use Loctite on all the studs prior to tighten the nuts **Part# NT1101**  
Nuts should be tighten with a torque wrench to 80 in/lbs



**Step 13:** Add **Part# NT1120** insulation sheet over the previously tightened brackets

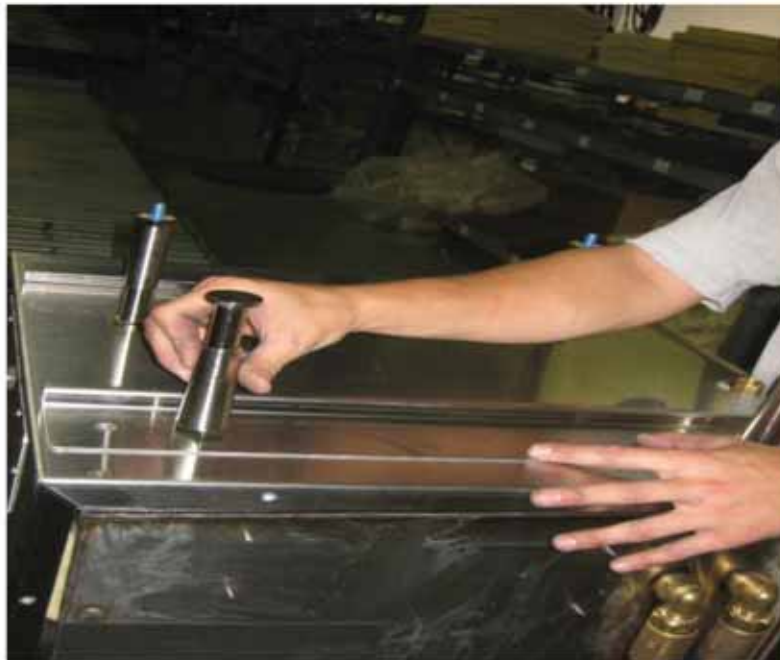


**Step 14:** Place the back insulation **Part# NT1162**



**Step 15:**

Place the bottom back on the unit as shown above



**Step 16:**

Install the two pan holders **Part# NT1027** and install the legs through the pan holders after applying Loctite. Leave the feet slightly tighten for future adjustment



**Step 17:** Secure the drip rails using (5) screws **Part# NT1104**



**Step 18:** Install the drain valve cover **Part# NT1048** using two screws **Part# NT1105**



**Step 19:** Complete assembly by tightening the feet using a Crescent Wrench

**Step 20:** Return unit to its normal upright position and wire elements per wiring diagram

# REPLACING NT1098 THERMOMETER ON INTEK XTREME STEAM



Figure 1

**Step 1:** Safely remove all power connections

**Step 2:** Remove left side panel and remove existing thermometer from front panel



Figure 2

**Step 3:** Cut the insulation in halves and slide the bottom half out to expose the bulb and bracket



Figure 4

**Step 4:** Remove damaged bulb, replace the thermometer bulb 1098 and apply heat sync compound to the bulb. If bracket is replaced apply heat sync compound to the backside of bracket (Compound does not come with the temperature gauge)



**Step 5:** Secure the bracket and bulb using two the 1102 nuts as shown above



**Step 6:** Replace the Insulation; install the gauge, and the left side panel. Reconnect power supply

## Watlo Heater Amp Reading During Operation

	AMPS +/- 10%	OHMS Per Element
208-14-3000	38.9	9.3
208-12-3000	33	10.5
208-8-3000	22	15
208-8-1000	38.5	10.5
208-6-1000	28.9	20
240-14-3000	33.7	12
240-12-3000	28.9	14
240-8-3000	19.2	20
240-8-1000	33.3	14
240-6-1000	25	27
480-12-3000	14.4	56.6

To receive the proper Ohms per element, disconnect all heater leads from the three position terminal block and test 1L1 to 1L1 - 2L2 to 2L2 - 3L3 to 3L3

To read the Amps per unit during normal operation, connect the Amp meter to the incoming power cord leads connecting to the Main Contactor. Amp out each lead.