

Parts Catalog



SP05

Mixer

Model: SP05

12/13/2017 Rev. A

IMPORTANT!

TO EXPEDITE SHIPMENT OF PARTS, ALWAYS SPECIFY MODEL, REV,
PART NUMBER, AND SERIAL NUMBER OF UNIT.

GLOBE FOOD EQUIPMENT COMPANY

2215 East River Road
Dayton, Ohio 45439

Parts Department

Toll Free 1-800-745-6238 · Fax (937) 290-0585

E-Mail: info@globefoodequip.com

Website: www.globefoodequip.com

Not for resale

Table of Contents

Description	Page
SP5 Mixer Base Components	4
SP5 Bowl Lift Components	6
SP5 Transmission Components	8
SP5 Motor Components	10
SP5 Wiring Diagram	12



SP5 Mixer Base Components

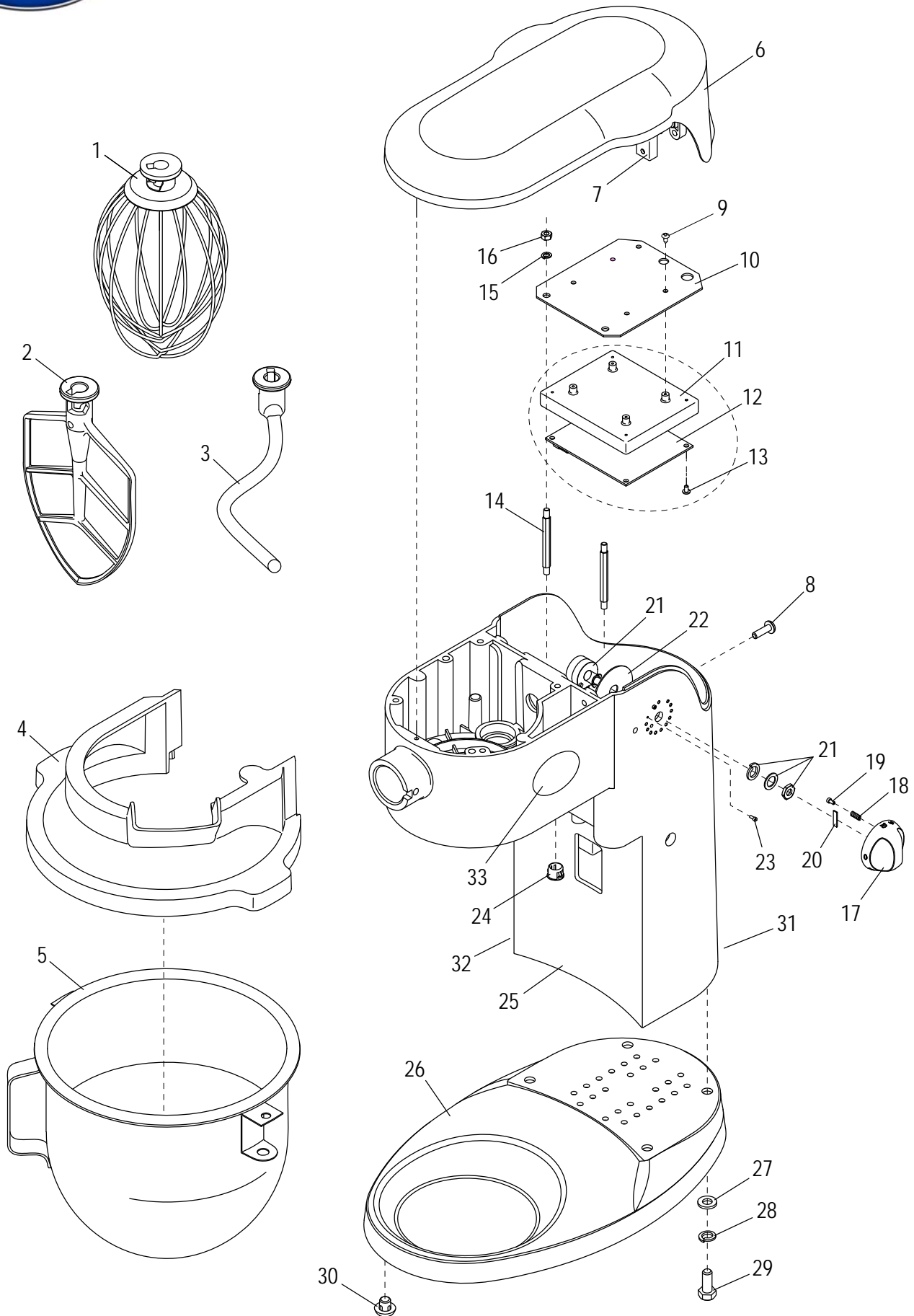



SP5 Mixer Base Components

Item	Part Number	Description	Qty	Serial Number
1	XXWhip-05	Whip	1	
2	XXBeat-05	Beater	1	
3	XXHook-05	Spiral Hook	1	
4	X5E01-1	Safety Guard	1	
5	XXBowl-05	Mixer Bowl	1	
6	X5A13-1	Mixer Cover	1	
7	X5A39	Mixer Cover Reinforcement	1	
8	H00523	Mixer Cover M5x18 Truss Hd Screw	1	
9	X00524	Circuit Board Housing Screw	4	
10	X5A21	Housing Mounting Plate	1	
11	X5A33	Circuit Board Housing	1	
12	X5A20-1	Electronic Circuit Board	1	
13	X00525	Circuit Board Mounting Screw	4	
14	X5A41	Mounting Plate Standoff	2	
15	H00320	Standoff Washer M5 Split Lock	2	
16	H00028	Hex Nut M5 - Zn	2	
17	X5A05-1	On/Off/Speed Selector	1	
18	X5A08-1	Selector Spring	1	
19	X5A09	Selector Plunger	1	
20	X5A44	Selector Alignment Tab	1	
21	X5A15	Potentiometer w/Hardware	1	
22	X5A16	Potentiometer Insulation Pad	1	
23	H00526	Selector Stop Screw M2x5 Socket Hd Cap	2	
24	X5A26	Hole Plug	1	
25	X5A25-1	Mixer Body	1	
26	X5A27	Mixer Base	1	
27	H00191	Flat Washer M8, 8.4 IDx16 ODx1.4-1.8mm thick DIN 125 - Zn	4	
28	H00527	Mixer Mounting M8 Split Lock Washer	4	
29	H00117	Hex Head Screw M8x20 - Zn	4	
30	X5UH-1260	Mixer Foot	4	
31	X91018	Label, Electrical Hazard	1	
32	X91019	Label Warning	1	
33	871-3	Label, Globe Logo	1	



SP5 Bowl Lift Components

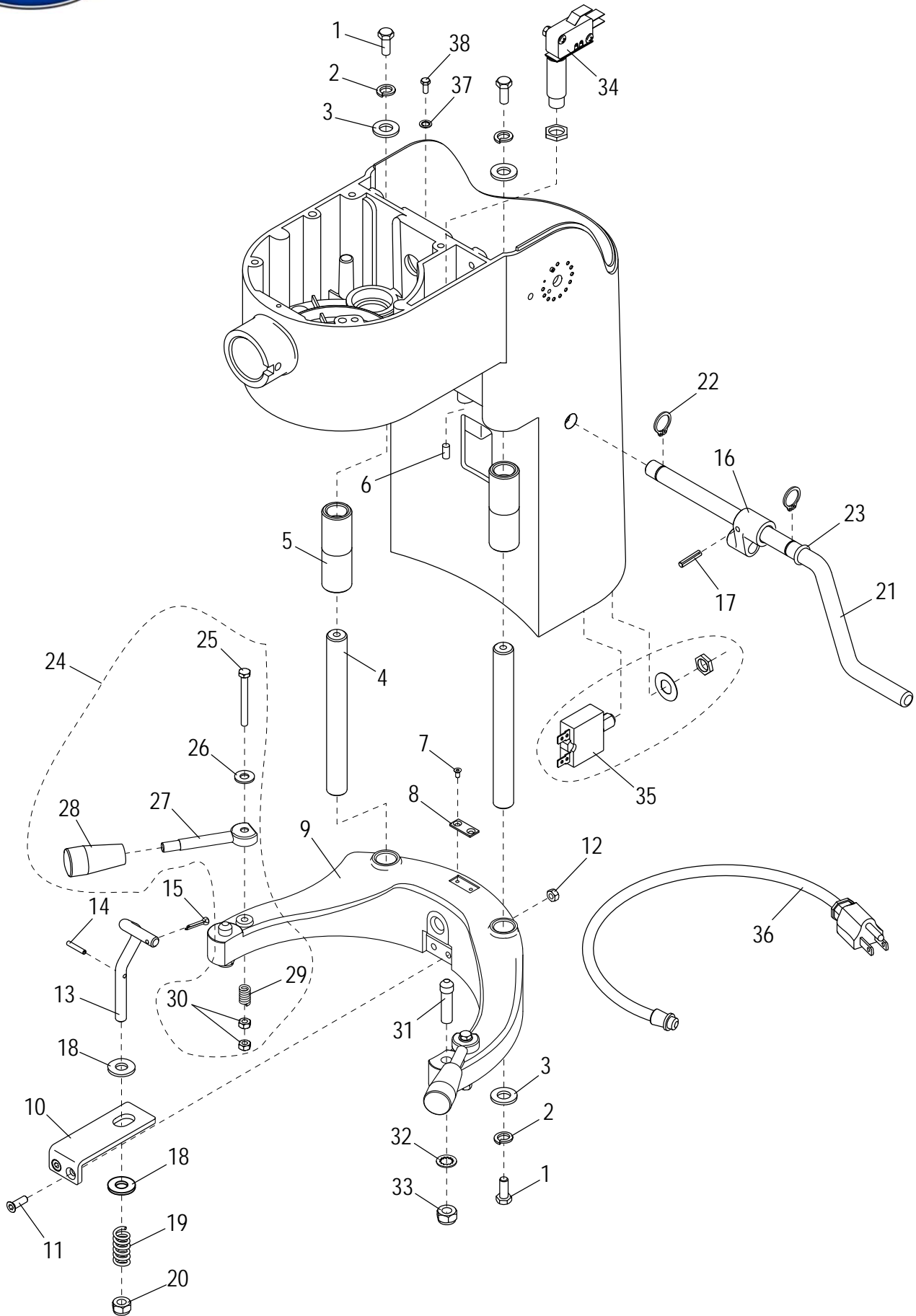



SP5 Bowl Lift Components

Item	Part Number	Description	Qty	Serial Number
1	H00197	Hex Hd Screw M6x15 - Zn	4	
2	H00042	Lock M6 Split Washer	4	
3	H00014	Flat M6 Washer - Zn	4	
4	X5B03	Bowl Lift Shaft	2	
5	X5B04	Lift Shaft Bushing	2	
6	H00183	Set Screw M5x10 Cup Pt. Hex Socket - BO	1	
7	H00528	Limit Pad Mounting M3x5 Flat Hd Screw	2	
8	X5B07	Bowl Limit Pad	1	
9	X5B08	Bowl Cradle	1	
10	X5B09	Bowl Lift Bracket	1	
11	H00305	Flat Hd Screw M5x15 Slotted - Nickel	2	
12	H00028	Hex Nut M5 - Zn	2	
13	X5B12	Bowl Lift Rod	1	
14	H00529	Lift Rod M3x16 Spring Pin	1	
15	H00530	Lift Rod Attachment M2x20 Cotter Pin	1	
16	X5B14	Bowl Lift Connector	1	
17	H00531	Connector M4x20 Spring Pin	1	
18	H00191	Flat Washer M8, 8.4 IDx16 ODx1.4-1.8mm thick DIN 125 - Zn	2	
19	X08091	Lift Rod Spring	2	
20	H00532	Drive Shaft M8 Lock Nut, Nylon Insert	1	
21	X5B20	Bowl Lift Handle	1	
22	X5B19	Bowl Lift Handle STW-12 Retaining Ring	2	
23	X5B22	Handle Seal 16x10x3mm O-Ring	1	
24	X08089-93	Bowl Clamp Assembly (Set/2)	1	
25		Bowl Clamp Screw	2	
26		Bowl Clamp #10 Flat Washer	2	
27		Bowl Clamp Arm	2	
28	X08090	Knob, Plastic	2	
29		Bowl Clamp Spring	2	
30		Bowl Clamp #10 Hex Nut	4	
31	X5B34	Bowl Lock Pin	2	
32	H00536	Bowl M8 Internal Tooth Lock Washer	2	
33	H00532	Drive Shaft M8 Lock Nut, Nylon Insert	2	
34	X5E02	Bowl Guard Interlock Microswitch Kit	1	
35	X00537	Overload Relay, 5 Amp	1	->6513800
35	X00538	Overload Relay, 8 Amp	1	6513800 ->
36	X5B23	Power Cord and Plug	1	
37	H00540	Ground Screw M5 Internal Tooth Lock Washer	1	
38	X00539	Ground M5x10 Hex Hd Screw (Green)	1	



SP5 Transmission Components

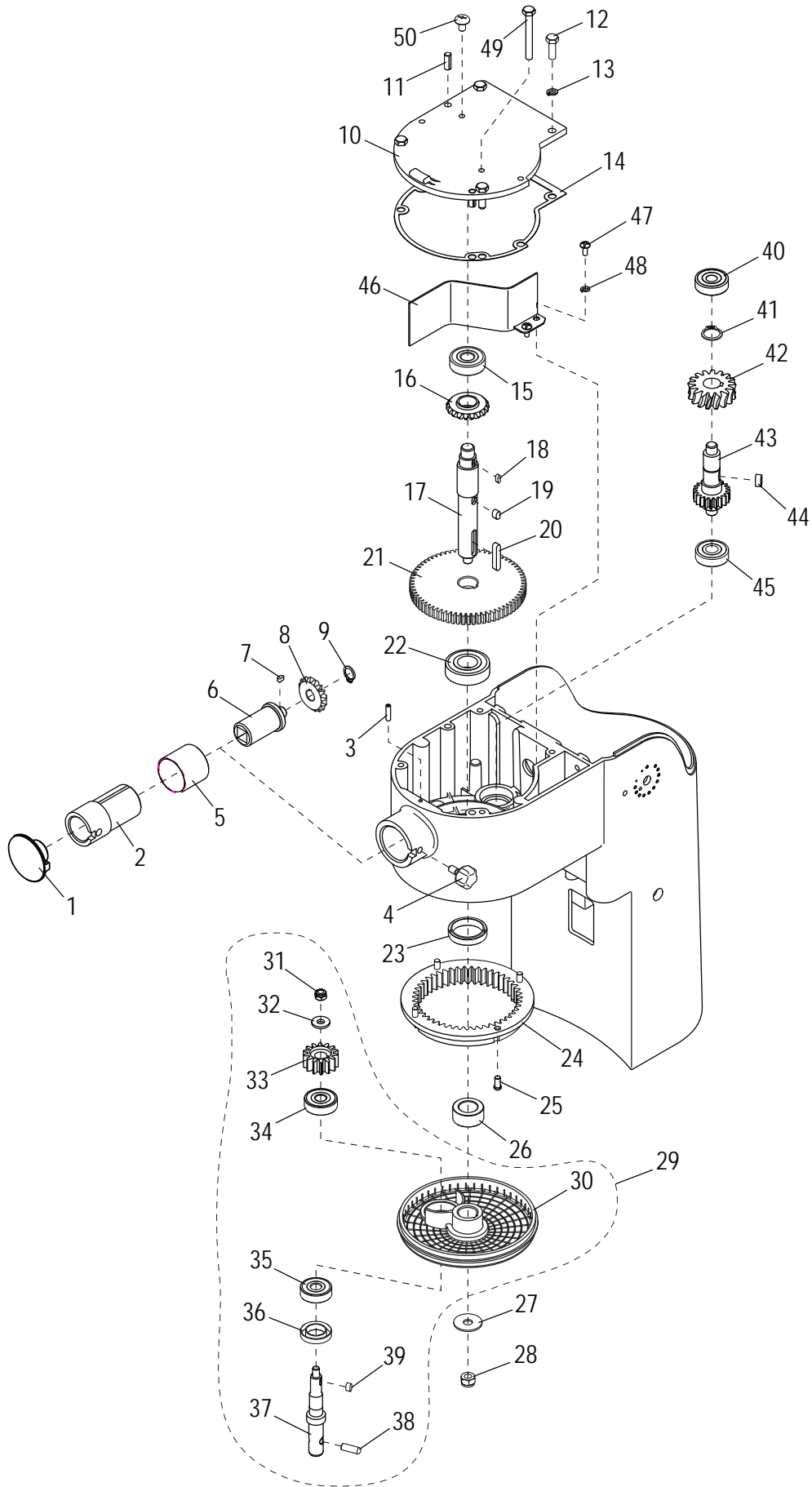



SP5 Transmission Components

Item	Part Number	Description	Qty	Serial Number
1	X5C01	Attachment Hole Plug	1	
2	X5C02	Attachment Hub	1	
3	H00541	Attachment Hub M4x16 Cup Point Set Screw	1	
4	X5C21	Attachment Release Knob	1	
5	X5C47	Anti-Oil Bushing	1	
6	X5C03	Level Drive Gear Hub	1	
7	H00542	Level Drive 3x3x6mm, Round Ends Gear Key	1	
8	X5C05	Level Drive Gear (16T)	1	
9	X5C06	Level Drive Gear STW-10 Retaining Ring	1	
10	X5C09	Transmission Case Cover	1	
11	X5C19	Locating M6 Spring Pin	2	
12	H00116	Hex Head Screw M6-1.0x20 - Zn	4	
13	H00042	Lock M6 Split Washer	4	
14	X5C10	Gasket	1	
15	X10117	Drive Shaft Upper Ball Bearing	1	
16	X5C12	Level Drive Gear (20T)	1	
17	X5C13	Drive Shaft	1	
18	H00543	Level Drive 3x3x8mm, Round Ends Gear Key	1	
19	H00544	Drive 5x5x8mm, Round Ends Gear Key	1	
20	H00545	Planetary Holder 5x5x28mm, Round Ends Key	1	
21	X5C17-1	Drive Gear (66T)	1	
22	X08114	Ball Bearing	1	
23	X5C22	Drive Shaft Oil-Seal	1	
24	X5C23	Internal Planetary Gear (47T)	1	
25	H00546	Planetary Gear Mounting M5x10mm Button Hd Screw	4	
26	X08116-1	Bushing & Seal Set	1	
27	X00547	Drive Shaft M8x30mm Flat Washer	1	
28	H00532	Drive Shaft M8 Lock Nut, Nylon Insert	1	
29	X01874	Planetary Assembly	1	
30	X5C32	Planetary Holder	1	
31	H00548	Hex Lock Nut M6 Nylon Insert	1	
32	H00120	Flat Washer M6x18mm	1	
33	X5C30	Pinion Gear (14T)	1	
34	X5C31	Transmission Shaft Lower Ball Bearing	1	
35	X08018	Ball Bearing	1	
36	X5C36	Planetary Oil-seal	1	
37	X5C37	Planetary Shaft	1	
38	X08037	Dowel Pin	1	
39	H00549	Pinion Gear 4x4x8mm, Round Ends Key	1	
40	X5C39	Transmission Shaft Upper Ball Bearing	1	
41	X5C40	Level Drive Gear STW-15 Retaining Ring	1	
42	X5C41	Level Drive Gear (16T)	1	
43	X5C42-1	Transmission Shaft (22T)	1	
44	H00550	Level Drive Gear 5x5x12mm, Round Ends Key	1	
45	X5C31	Transmission Shaft Lower Ball Bearing	1	
46	X5C45	Divider Plate	1	
47	H00551	Divider Plate M4 Split Lock Washer	2	
48	H00552	Divider Plate Mounting M4x10 Pan Hd Screw	2	
49	H00553	Screw M6x55mm Hex Hd	1	
50	H00554	Screw M6x10mm Pan Hd	1	



SP5 Motor Components

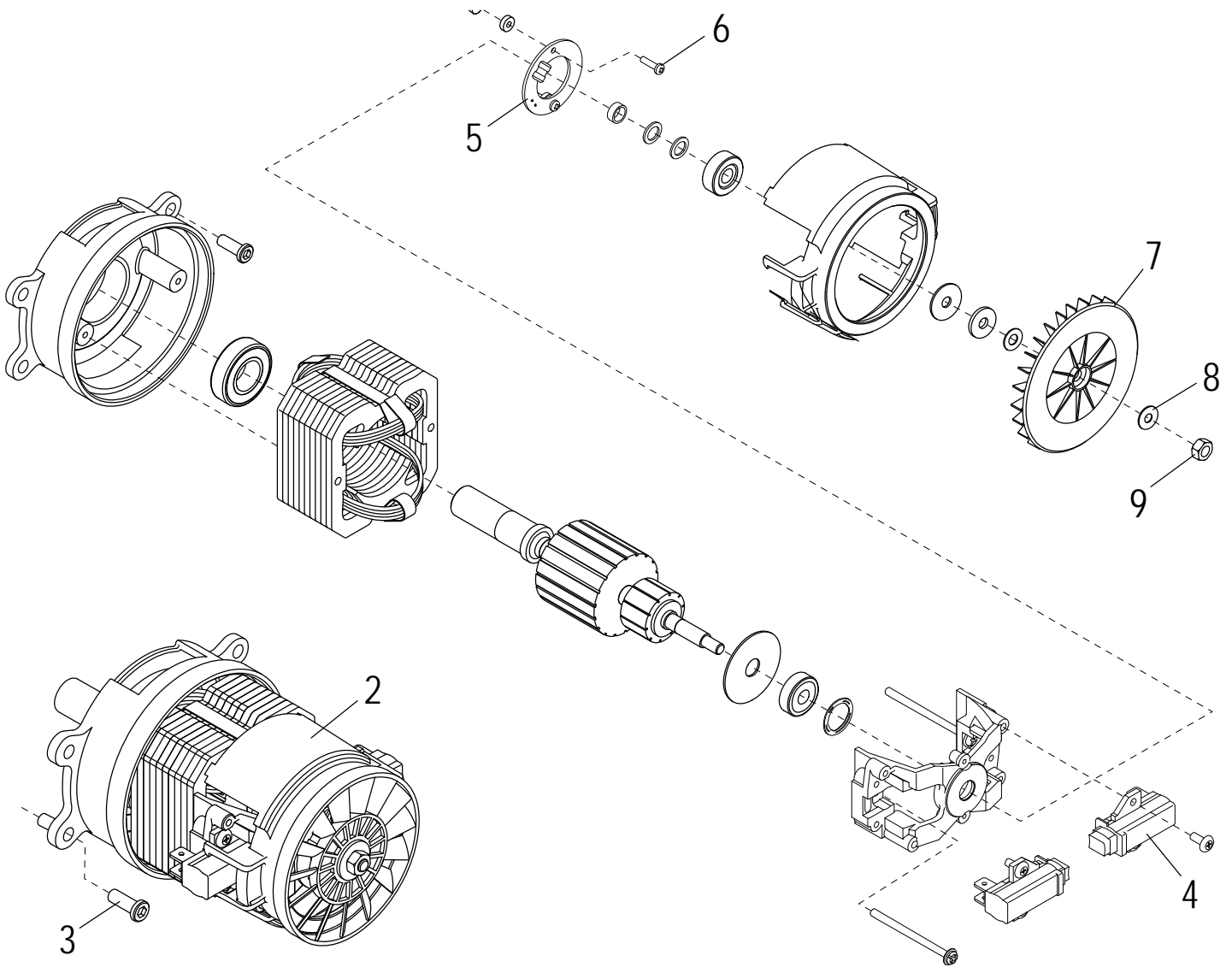



SP5 Motor Components

Item	Part Number	Description	Qty	Serial Number
1	X00558	Motor Replacement Kit (Not shown) <small>may repl. req. to comply w/higher arr</small>	1	
2	X00559	Motor Assembly	1	6513800 ->
3	X00556	Motor Mounting M6x16 SHCS Screw	4	
4	X5D09	Carbon Brush, Old Style	2	->6513800
4	X5D09-1	Carbon Brush, New Style	2	6513800 ->
5	X5D15-1	Tachometer	1	
6	H00557	Tach. Mounting M3x14 Pan Hd, Nylon Screw	2	
7	X5D11	Motor Fan, Old Style	1	->6513800
7	X5D11-1	Motor Fan, New Style	1	6513800 ->
8	H00120	Flat Washer M6x18mm	1	
9	H00555	Nut M6-1.0 Hex – LH Thd Reverse	1	



SP5 Wiring Diagram

