

Parts Catalog



SP25

Mixer

Model: SP25

10/02/2019 Rev B

IMPORTANT!

TO EXPEDITE SHIPMENT OF PARTS, ALWAYS SPECIFY MODEL, REV,
PART NUMBER, AND SERIAL NUMBER OF UNIT.

GLOBE FOOD EQUIPMENT COMPANY

2215 East River Road
Dayton, Ohio 45439

Parts Department

Toll Free 1-800-745-6238 · Fax (937) 290-0585

E-Mail: info@globefoodequip.com

Website: www.globefoodequip.com

Not for resale

Table of Contents

Description	Page
SP25 Base Components	4
SP25 Head Components	8
SP25 Hub Assembly Components	10
SP25 Planetary Components	12
SP25 Gearbox Components	14
SP25 Motor Components	18
SP25 Manual and Digital Timer	20
SP25 Electrical Diagram - 120V Single Phase - Prior	22
SP25 Wiring Diagram - 120V Single Phase - Prior	23
SP25 Wiring Diagram - 120V Single Phase - Digital Timer - Post	24



SP25 Base Components

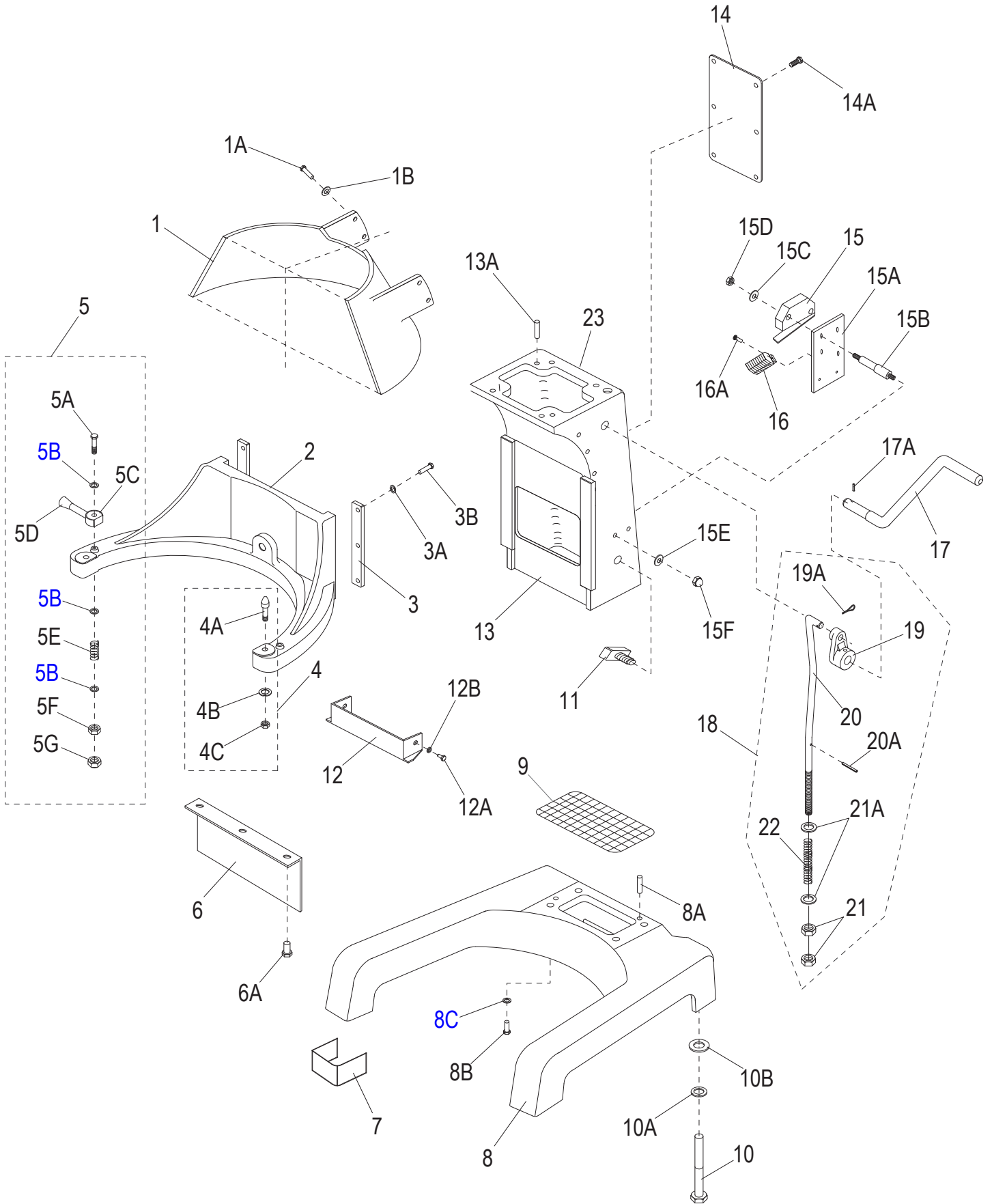



SP25 Base Components

Item	Part Number	Description	Qty	Serial Number
1	X25036	Rear Guard	1	
1A	X25097	Screw M6x14mm Hex Hd	4	
1B		Washer M6 Flat	4	
2	X25034-DG	Bowl Cradle	1	7511135 ->
3	X25035	Cradle Slide Guide	2	
3A		Washer M6 Split Lock	6	
3B	X25098	Screw M6x14mm Hex Hd	6	
4	X25100	Dowel Screw Assembly	2	
4A		Dowel Screw	2	
4B	X25100A	Washer M6 Split Lock	2	
4C	X25101	Nut M6 Hex	2	
5	X10020	Bowl Clamp Assembly (Set/2)	2	
5A		Clamp Screw M8x80mm	2	
5B		Washer M8 Flat	4	
5C	X10020-1	Bowl Clamp (Set/2)	1	
5D		Clamp Handle	2	
5E		Spring	2	
5F		Nut M8 Hex	2	
5G		Nut M8 Acorn	2	
6	X25149	Cover, Bowl Cradle	1	
6A	X25150	Screw M6x14mm Hex Hd	3	
7	X25157-158	Front/Rear Rubber Feet (Set/4)	1	
8	X25038-DG	Mixer Base	1	
8A		Dowel Ø8x16mm Pin	2	
8B		Screw M10x40mm Hex Hd	4	
8C		Washer M10 Flat	4	
9	X25037	Screen Base	1	
10	X25039	Screw M10x50mm Hex Hd	4	
10A		Washer M10 Split Lock	4	
10B		Washer M10 Flat	4	
11	X20027-2	Circuit Breaker (New Style 13A)	1	
12	X25102	Cover, Center Column	1	
12A	X25103	Screw. Hex Head - SS	2	
12B		Washer M6 Flat	2	
13	X25044-DG	Mixer Column	1	7511135 ->
13A		Dowel Ø8x16mm Pin	2	
14	X25050	Plate Ø8x16mm Rear Cover	1	
14A	X25051	Rd Hd Screw-PHH #10-24x1/4, SS-18	6	
15	X25047	Microswitch M5x6mm Bowl Interlock (Raise/Lower)	1	
15A	X25047-1	Bracket, Microswitch Mounting	1	
15B		Standoff	2	
15C		Washer, Flat	2	
15D		Nut M4 Hex	2	
15E		Washer M6 Flat	2	
15F		Nut M6 Acorn	2	
16		Connecting Block	1	
16A		Screw M3x10mm Round Hd	2	
17	X25049	Bowl Lift Lever	1	
17A	X25104	Dowel Pin Ø5x30mm	1	
18	X25049A	Bowl Lift Rod Assembly	1	
19	X25048	Cam, Bowl Lift	1	
19A		Cotter Pin	1	
20	X25046	Rod, Bowl Lift	1	



SP25 Base Components

Item	Part Number	Description	Qty	Serial Number
20A	X25045	Roll Pin Ø3x28mm	1	
21		Nut M10 Hex	2	
21A	X10034	Washer M10 Flat	2	
22	X25041	Spring	1	
23	X91014	Label, Hazardous Voltage (Not Shown)	1	



INTENTIONALLY LEFT BLANK PAGE



SP25 Head Components

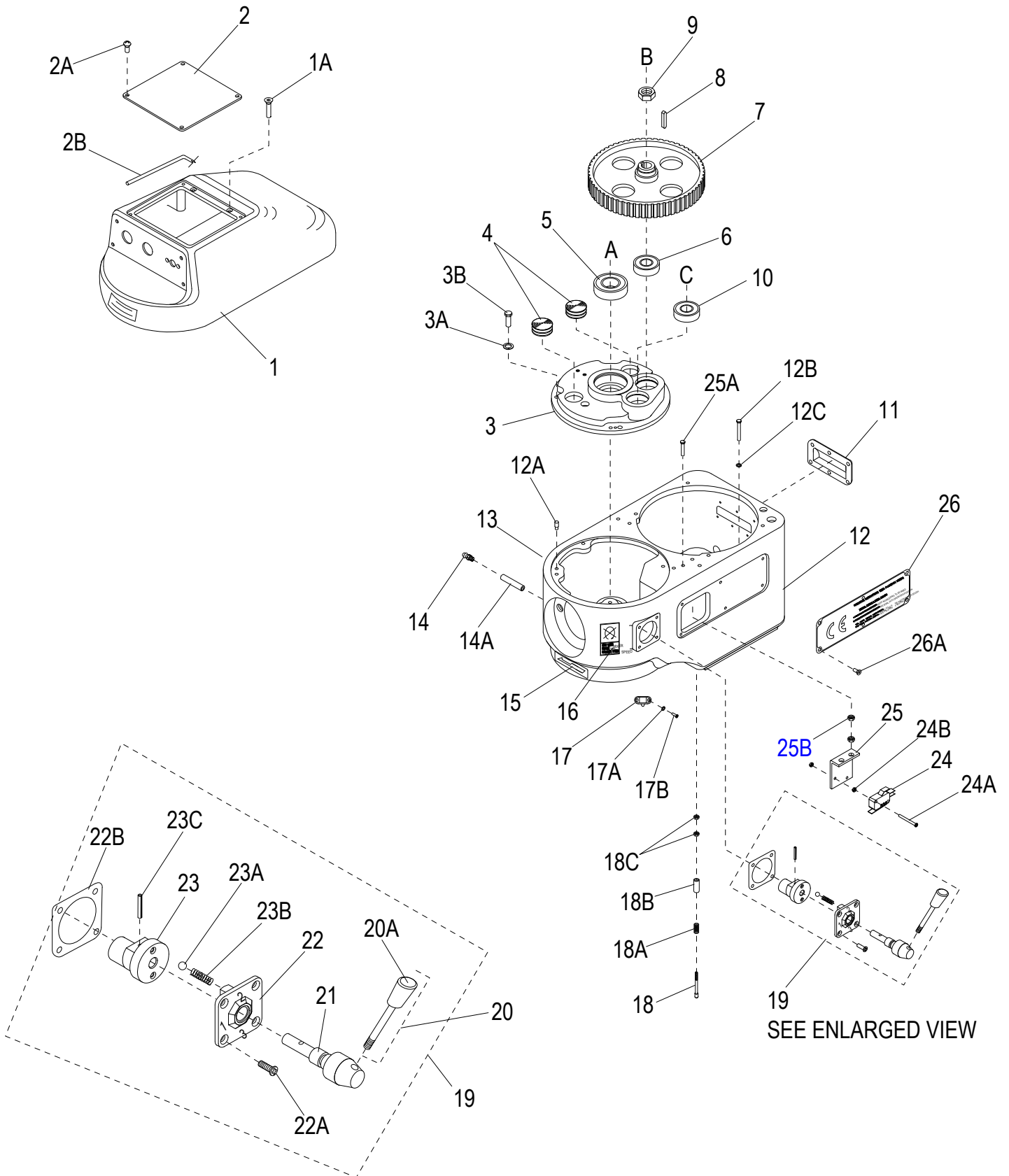



SP25 Head Components

Item	Part Number	Description	Qty	Serial Number
1	X25004-DG	Cover, Transmission	1	
1A	X25190	Screw M6x80mm Flat Hd	2	
2	X25002	Cover, Switch Box	1	
2A	X25001	Screw M5x10mm Truss Hd	4	
2B	X25003	Gasket	1	
3	X25072	Cover, Gear Housing	1	
3A		Washer M6 Split Lock	4	
3B		Screw M6x16mm Hex Hd	4	
4	X10073	Oil Plug	2	
5	X10102	Ball Bearing	1	
6	X25073	Ball Bearing	1	
7	X25075	Wheel, Main Cog	1	
8	X40073	Key H-5xW-5xL-20mm Round Ends	1	
9	X25077	Nut M16 Jam	1	
10	X25073	Ball Bearing	1	
11	X25071	Plate, Ventilation	1	
12	X25082	Transmission Case, Fixed Bowl Guard	1	
12	X25082-1	Transmission Case, Removable Bowl Guard	1	
12A		Dowel Pin Ø8xM6x10mm Threaded	2	
13	X91009	Label, Lubricate	1	
14	X10900	Grease Fitting	1	
14A	X10217	Grease Tube	1	
15	X91012	Label, Arrow	1	
16	X91010	Label, Stop To Chg Gears	1	
17	X10134	Safety Guard Spring Lock	1	
17A	X10134A	Washer M3 Split Lock	2	
17B	X10134B	Round Hd Screw-PHH M3-0.5x8mm, SS-18	2	
18	X10043	Touch Shaft, Brass	1	
18	X10043N	Touch Shaft, Nylon	1	
18A	X30095	Spring	1	
18B		Tube	1	
18C	X30186	Hex Nut M5-0.8 OD-8, TH-4mm, Zinc	2	
19	X25052-55	Gear Shift Lever Assembly	1	
20		Gear Shift Lever With Knob	1	
20A	X10045-1	Knob, Gear Shift	1	
21		Shaft	1	
22		Cover	1	
22A	X25166	Flat Hd Screw-PHH M5-0.8x16mm, Zinc	4	
22B	X10199	Gasket	1	
23		Shaft Bias	1	
23A		Roller	2	
23B		Spring	2	
23C		Roll Ø3x28mm Pin	1	
24	X10057	Microswitch, Interlock	1	
24A		Screw M3x20mm Round Hd	2	
24B		Nut M3 Hex	4	
25	X10058	Bracket, Microswitch	1	
25A		Screw M6x20mm Round Hd	2	
25B		Nut M6 Hex	4	
26	X25061	Plate, Warning	1	
26A	X25060	Screw M4x6mm Pan Hd	6	



SP25 Hub Assembly Components

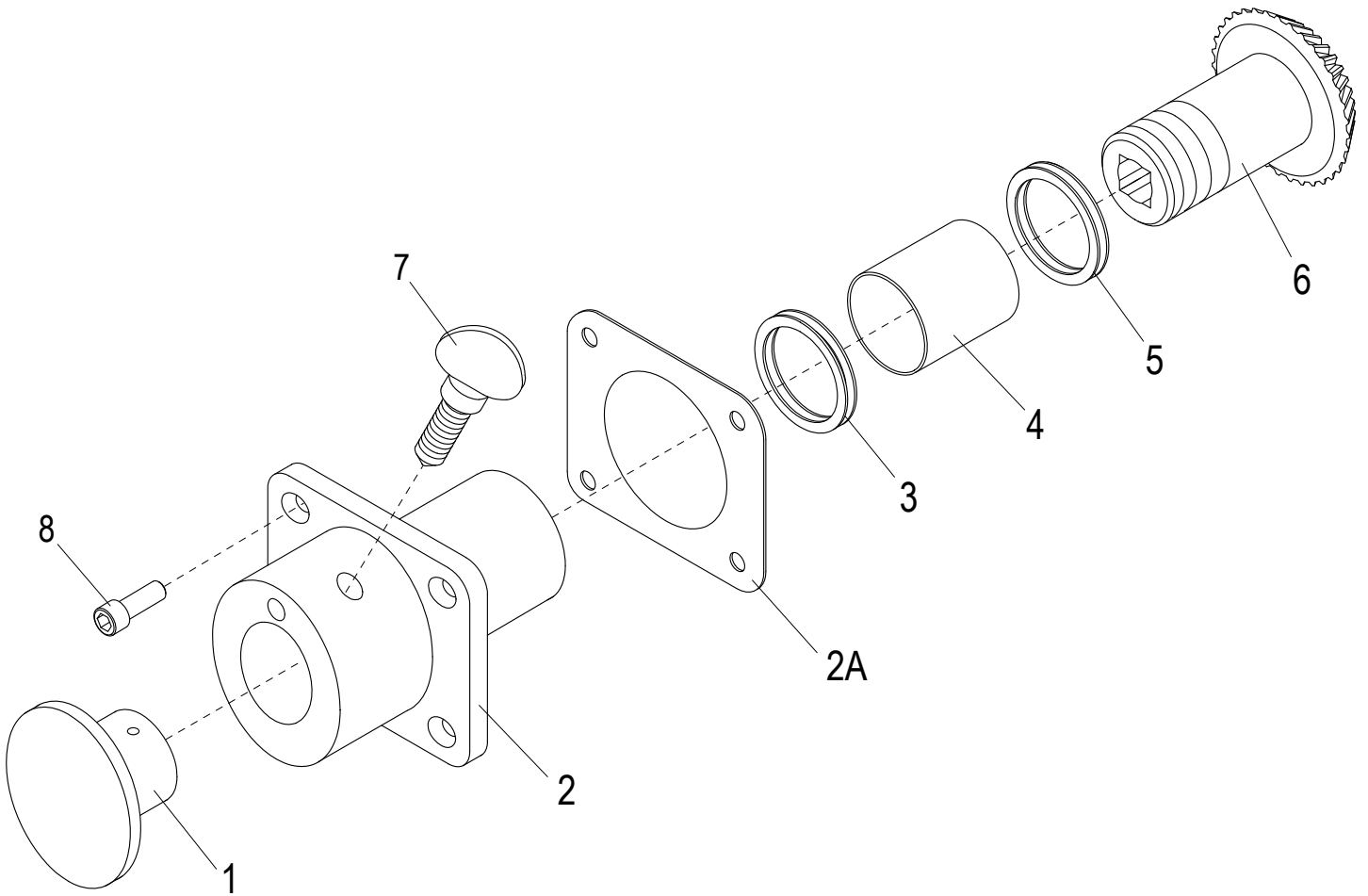



SP25 Hub Assembly Components

Item	Part Number	Description	Qty	Serial Number
1	X10007	Attachment Hole Plug	1	
2	X25018-DG	Attachment Hub	1	7511135 ->
2A		Gasket	1	
3	X10004	Thrust Washer ID-36, OD-47, TH-0.5mm *	1	
4	X10075	Bearing *	1	
5	X30018-1	Thrust Washer ID-35mm, OD-55mm, TH-1mm	2	
6	X10003	Level Drive Gear (35T)	1	
7	X10005	Thumb Screw 1/2-13x3/4"	1	
8	X80B52	Socket Hd Cap Screw M6-1.0x20mm, B.O.	4	

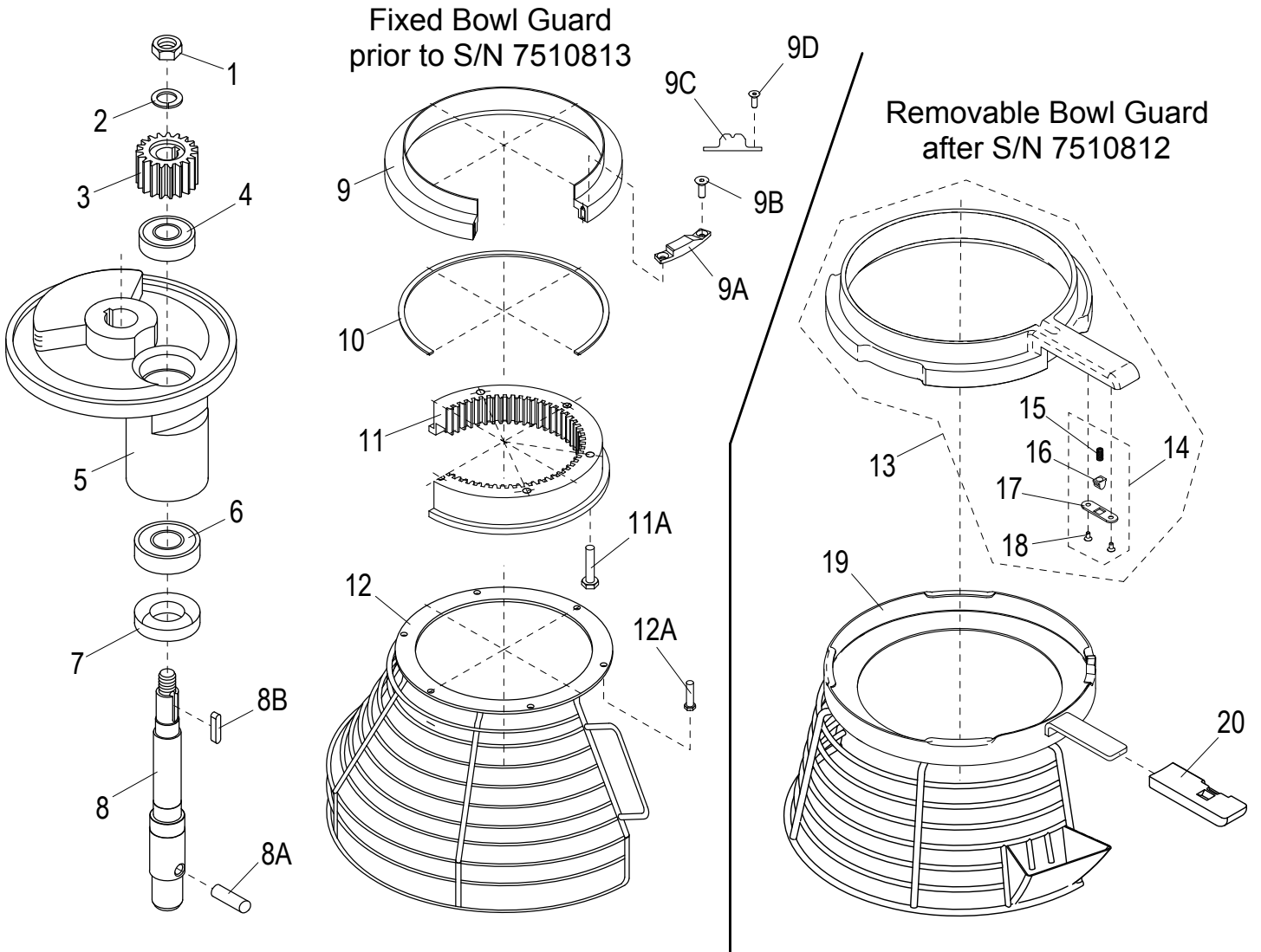



SP25 Planetary Components

Item	Part Number	Description	Qty	Serial Number
1	X10008	Hex Nut M12-1.25, OD-19, HT-10mm, Zinc	1	
2		Washer M12 Split Lock	1	
3	X10009	Pinion, Beater (19T)	1	
4	X10010	Ball Bearing	1	
5	X10011-DG	Planetary Holder	1	
6	X10012	Ball Bearing	1	
7	X10013	Oil Seal	1	
8	X10015	Planetary Shaft	1	
8A	X10080	Dowel Pin	1	
8B	X10014	Key H-5xW-5xL-17mm, Round Ends (Incl. with X10015)	1	
9	X10076P	Slide Sheath, Molded	1	->7510812
9A	X10041	Touch Mass	1	->7510812
9B	X10042	Flat Hd Screw-Phillips M4-0.7x10mm, Zn	2	->7510812
9C	X10135	Safety Guard Spring Lock Fixture	1	->7510812
9D		Screw M4x10mm Round Hd	2	->7510812
10	X10077	Teflon Mat	1	->7510812
11	X25088	Ring Gear (63T)	1	->7510812
11A	X25095	Screw M6x30mm Hex Hd	6	->7510812
12	X25089-90	Front Interlock Guard Assembly	1	->7510812
12A	X10083	Ext. Hex Hd Screw M5-0.8x10mm, SS	6	->7510812
13	X200S2	Plastic Slide Sheath, Removable Safety Guard	1	7510813 ->
14	X200S3	Spring Plunger Hardware Kit	1	7510813 ->
15		Spring	1	7510813 ->
16		Plunger	1	7510813 ->
17		Plate, Plunger Retention	1	7510813 ->
18		Screw M3x8mm Flat Hd	2	7510813 ->
19	X250S1	Bowl Guard Assembly, Stainless Steel	1	7510813 ->
20	X20504	Handle, Plastic - Removable Safety Guard	1	7510813 ->



SP25 Gearbox Components

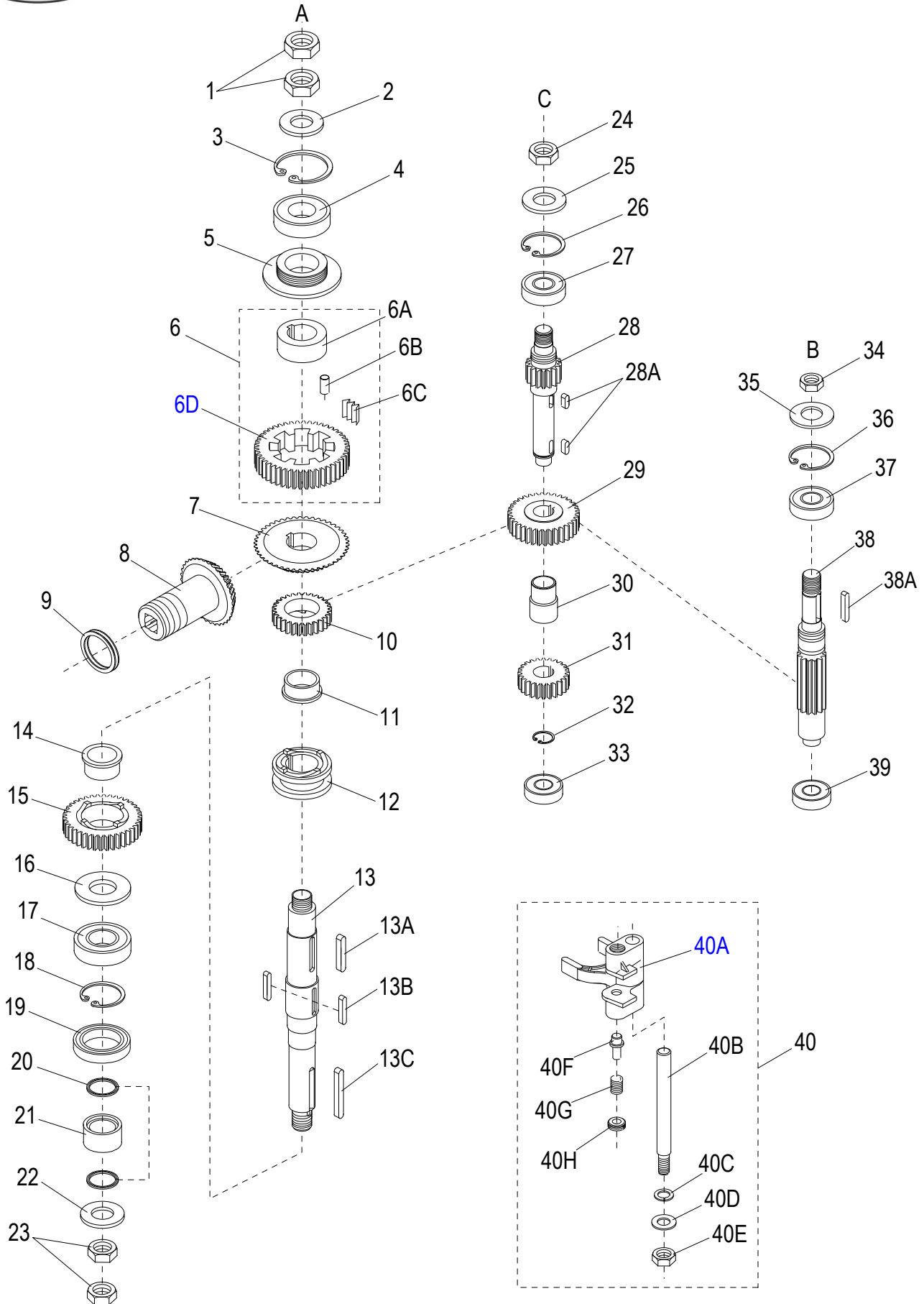



SP25 Gearbox Components

Item	Part Number	Description	Qty	Serial Number
1	X25105	Nut M18 Stop	2	
2		Washer M18 Flat	1	
3	X25106	Int. Retaining Ring ID-2, G-2.122, OD-2.210, TH-0.062" B.O.	1	
4	X10102	Ball Bearing	1	
5	X25107	Lead-In Oil Pad	1	
6	X25108-111	Slow Speed Gear Assembly	1	
6A	X25108	Bushing	1	
6B		Dowel Pin	1	
6C		Slice Spring	1	
6D		Gear, Slow Speed (46T)	1	
7	X10095	Gear, Bevel (46T)	1	
8	X10003	Level Drive Gear (35T)	1	
9	X30018-1	Thrust Washer ID-35mm, OD-55mm, TH-1mm	1	
10	X25113	Gear, Clutch (28T)	1	
11	X10097	Bushing, Clutch	1	
12	X10110	Sleeve, Clutch	1	
13	X25124	Drive Shaft	1	
13A	X25115	Shaft Key 6x6x27mm	1	
13B	X25126	Shaft Key 5x5x27mm	2	
13C	X25125	Shaft Key 6x6x45mm	1	
14	X25116	Bushing, Clutch	1	
15	X25117	Gear, Clutch (38T)	1	
16	X25118	Washer, Stepped	1	
17	X10102	Ball Bearing	1	
18		Retaining Ring RTW-52	1	
19	X10105	Oil Seal	1	
20	X10103	O-Ring 28x22x3mm	2	
21	X25121	Guard, Oil Bushing	1	
22		Washer M20 Flat	1	
23	X10106	Thin Hex Nut 3/4"-16, OD-1-1/8", HT-27/64", Zn	2	
24	X10008	Hex Nut M12-1.25, OD-19, HT-10mm, Zinc	1	
25		Washer M12 Flat	1	
26	X25145	Retaining STW-35 Ring	1	
27	X25073	Ball Bearing	1	
28	X25144	Transmission Shaft (15T)	1	
28A	X25143	Shaft Key 5x5x10mm	2	
29	X25142	Gear (34T)	1	
30	X25138	Bushing, Spacer	1	
31	X10121	Gear (24T)	1	
32	X10120	Retaining Ring STW-19	1	
33	X25134	Ball Bearing	1	
34	X25141	Nut M16 Jam	1	
35		Washer, Flat M16	1	
36	X25140	Retaining Ring #35	1	
37	X25073	Ball Bearing	1	
38	X25139	Shaft, Master (12T)	1	
38A	X40073	Key H-5xW-5xL-20mm Round Ends	1	
39	X25134	Ball Bearing	1	
40	X25128-133	Yoke Shifter Assembly	1	
40A		Yoke Shifter	1	
40B		Guide, Rod Shifter	1	
40C		Washer 3/8" Split Lock	1	
40D		Washer 3/8" Flat	1	



SP25 Gearbox Components

Item	Part Number	Description	Qty	Serial Number
40E		Nut 3/8-16 Stop	1	
40F		Plunger, Yoke Shifter	2	
40G		Spring, Yoke Shifter	2	
40H		Spring, Retainer	2	



INTENTIONALLY LEFT BLANK PAGE



SP25 Motor Components

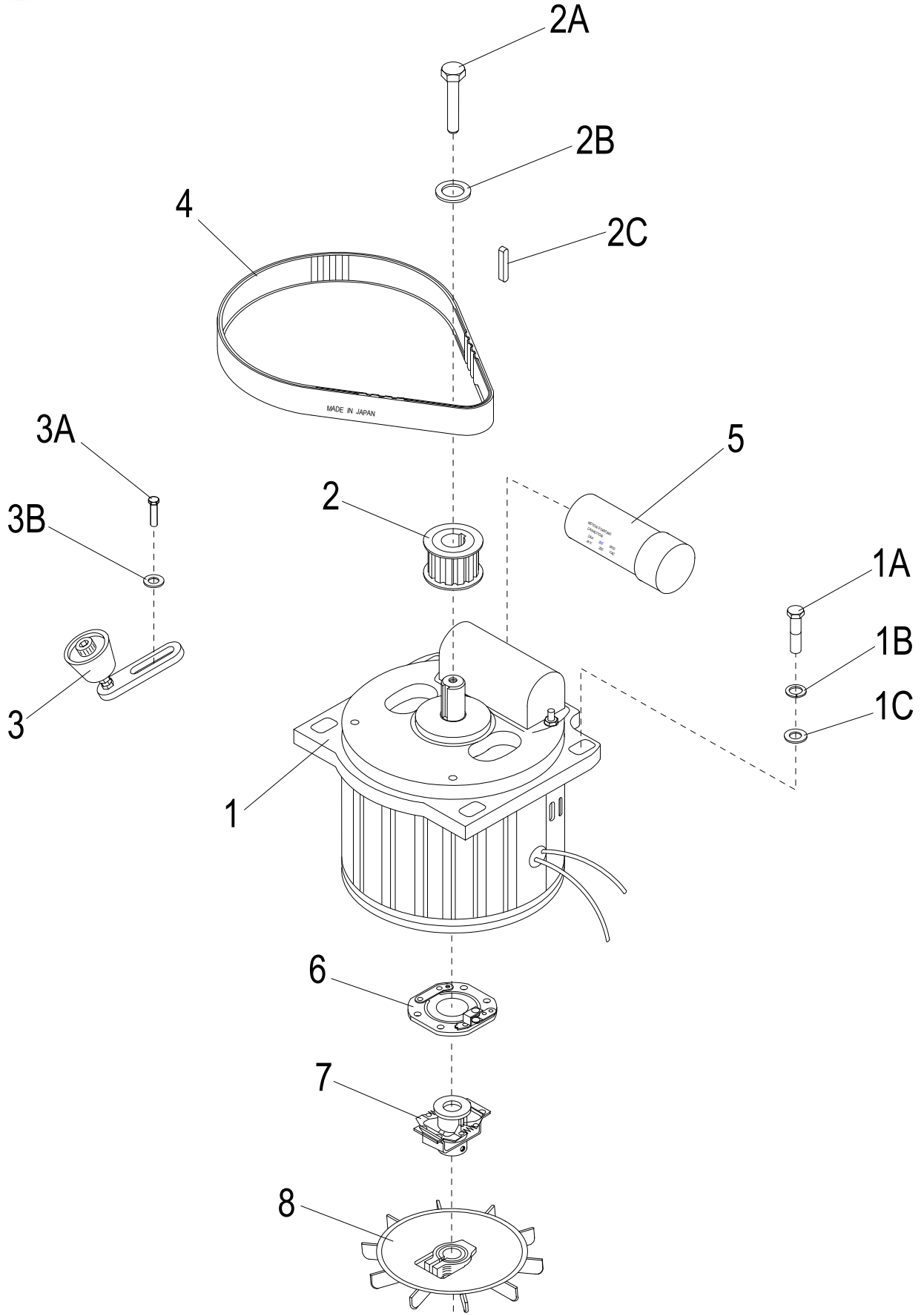



SP25 Motor Components

Item	Part Number	Description	Qty	Serial Number
1	X25063	Motor, 3/4 HP 120/60/1	1	
1A	X25064	Screw M6x24mm Hex Hd	4	
1B		Washer M6 Split Lock	4	
1C		Washer M6 Flat	4	
2	X25066	Wheel, Motor Cog (15T)	1	
2A	X25070	Screw M6x24mm Hex Hd	1	
2B	X25069	Flat Washer, M6 ID-6mm, OD-24mm, TH-3mm, Thick	2	
2C	X25068	Shaft Key 5x5x25mm	1	
3	X25147	Belt Tensioner	1	
3A	X25148	Screw M8x24mm Hex Hd	2	
3B		Washer M8 Flat	2	
4	X25067-1	Belt 255L - Old Style	1	
4	X25067-2	Belt 259L - Old Style	1	
4	X25067-3	Belt 263L	1	7510056 ->
5	X20026	Capacitor, Start - 300Mf	1	
6	X10051	Switch, Platinum	1	
7	X25059	Clutch	1	
8	X25056	Cooling Fan	1	
-	300		0	

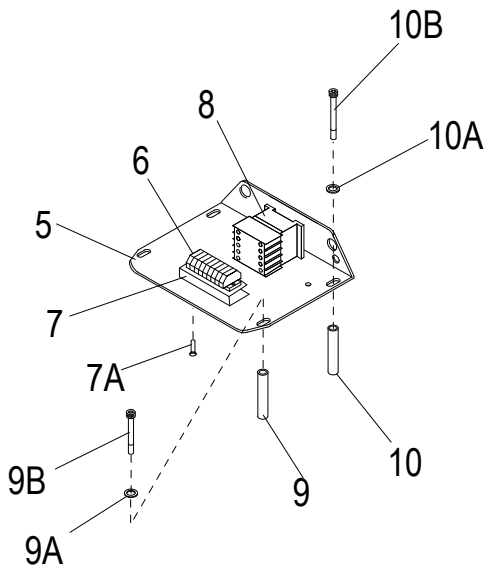
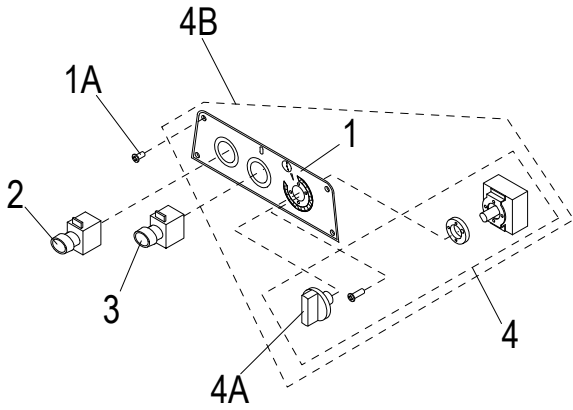

Manual Timer

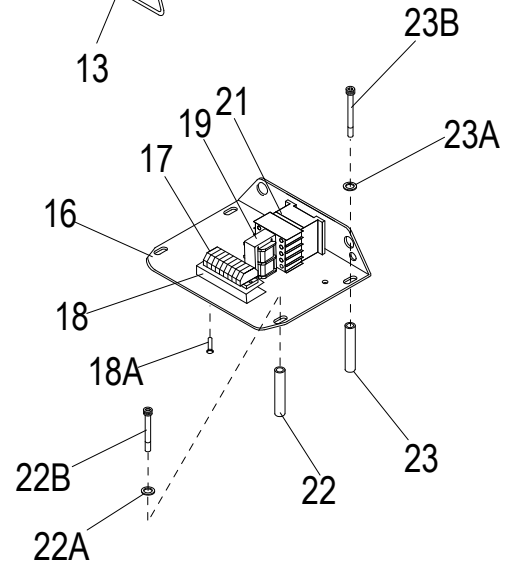
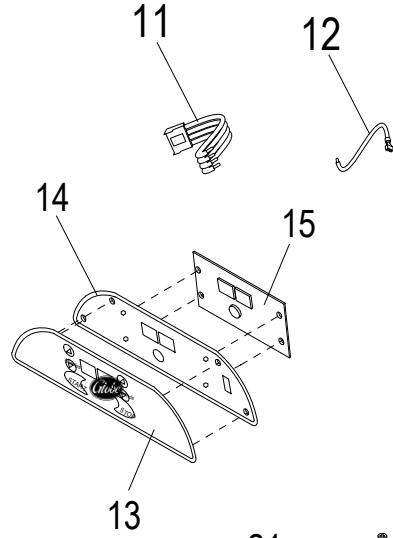

Digital Timer



SP25 Manual and Digital Timer

Item	Part Number	Description	Qty	Serial Number
1	X10002	Control Panel	1	
1A	X10179	Screw M4x10mm Truss Hd - Control Panel Mounting	4	
2	X10050	Emergency Stop Button	1	
3	X10049	Start Button	1	
3A	X10049-1	Boot, Start/Stop Switch Button (Not Shown)	2	
4	X10137	Timer Assembly With Knob	1	
4A	X10137-1	Timer Knob	1	
4B	X25296	Timer Assembly With Control Panel	1	
5	X25014	Plate, Electronics Mounting	1	
6	X10029A	Connecting Block Set	1	
6	X10029-2G	Connecting Block, Gray (2C)	11	
6	X10029-EC	Connecting Block End Cap	1	
7	X25014A	Plate, Connecting Block Mounting	1	
7A	X25013	Screw M6x12mm Hex Hd	2	
8	X30011ABB	Contactors	1	->7212460
9	X25191	Tube, Support	2	
9A		Washer M6 Flat	2	
9B	X25189	Screw M6x64mm Hex Hd	2	
10	X25080	Tube, Support	2	
10A		Washer M6 Flat	2	
10B	X25081	Screw M6x80mm Socket Hd	2	
11	X00675	4 Wire Harness With Connector	1	
12	X00676	Single Wire With Quick Connect	2	
13	X00565	Switch, Membrane	1	
14	X10336	Aluminum Panel	1	
15	X00568	Control Board	1	
16	X25014	Plate, Electronics Mounting	1	
17	X25012	Connecting Block Set	1	
17	X10029-2G	Connecting Block, Gray (2C)	11	
17	X10029-EC	Connecting Block End Cap	1	
18	X25014A	Plate, Connecting Block Mounting	1	
18A	X25013	Screw M6x12mm Hex Hd	2	
19	X00569	Control Transformer Assembly	1	
20	X00570	Control Transformer Fuse (Not Shown)	1	
21	X20028ABB	Contactors	1	->7212460
22	X25191	Tube, Support	2	
22A		Washer M6 Flat	2	
22B	X25189	Screw M6x64mm Hex Hd	2	
23	X25080	Tube, Support	2	
23A		Washer M6 Flat	2	
23B	X25081	Screw M6x80mm Socket Hd	2	



SP25 Electrical Diagram - 120V Single Phase - Prior

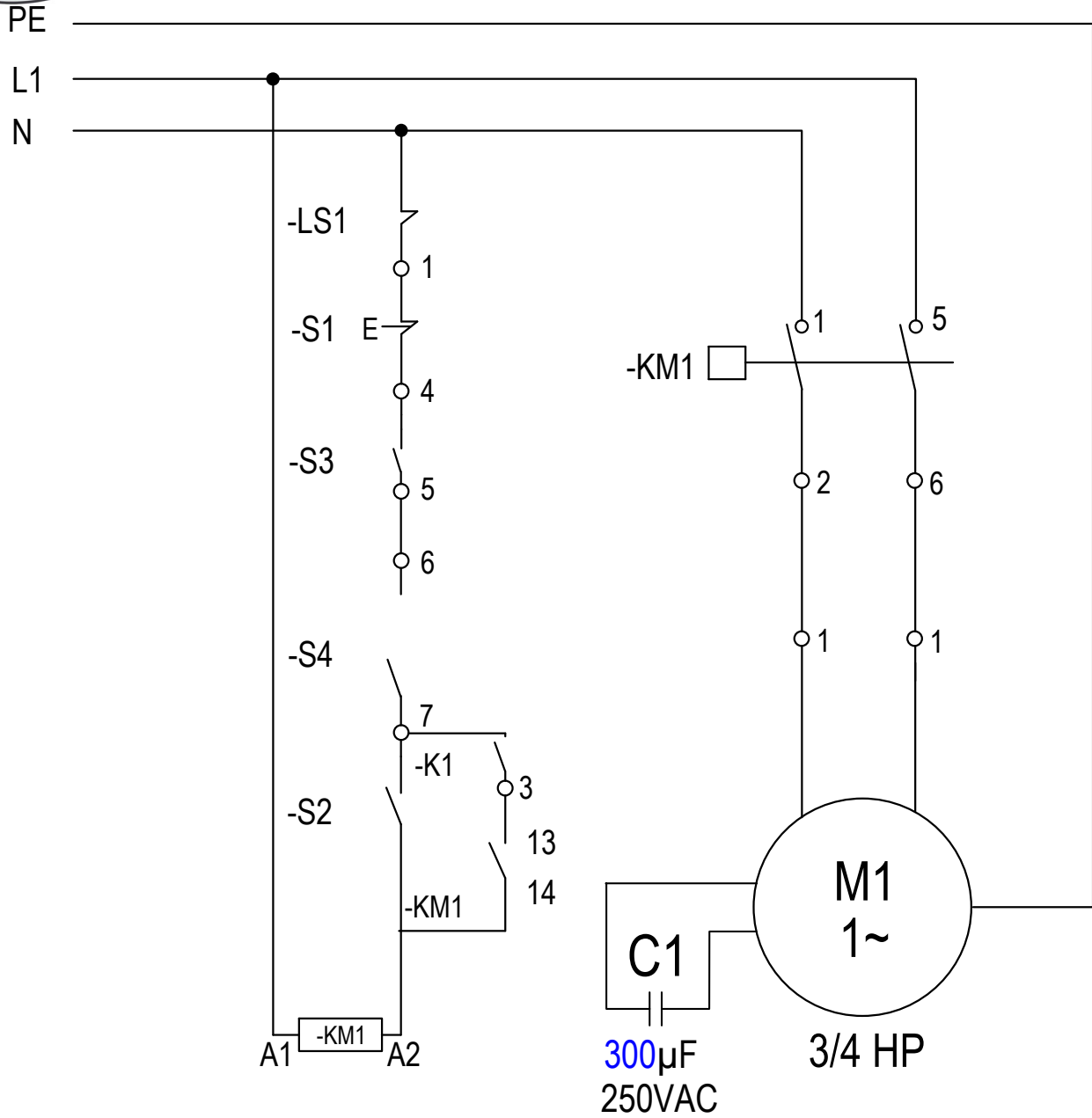

Item	Description	Qty
C1	Capacitor	1
S1	Emergency Stop Button	1
S2	Start Button	1
S3	Microswitch (Interlock Guard)	1
S4	Microswitch (Bowl Lift)	1
KM1	Contactor Coil 120V 60HZ	1
M1	Motor 3/4 Hr Single Phase 120V	1
LS1	Circuit Breaker	1
KI	Timer	1



SP25 Wiring Diagram - 120V Single Phase - Prior

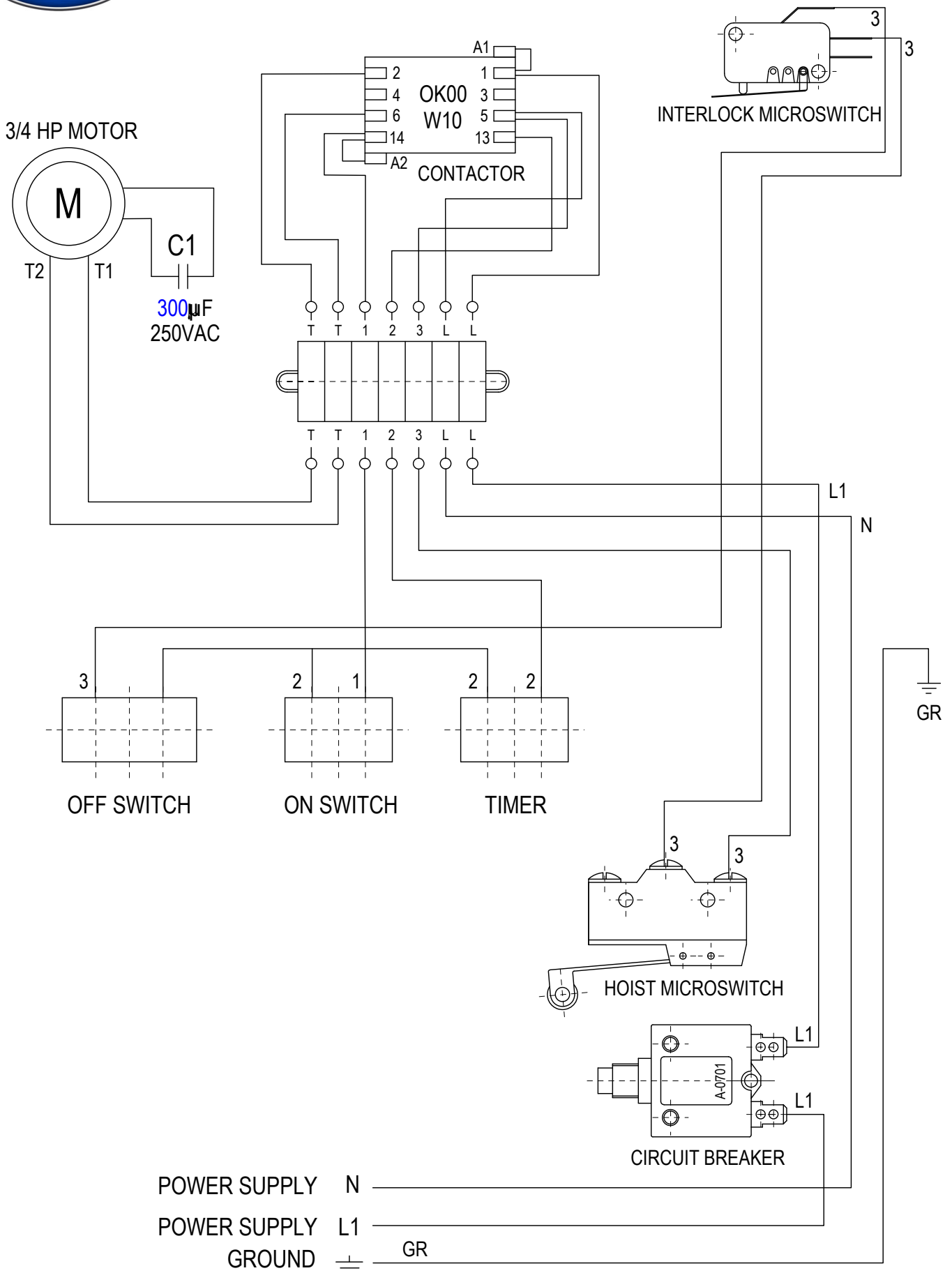

POWER SUPPLY N
POWER SUPPLY L1
GROUND

