

# Parts Catalog



**S13A-15**

## **S-Series Slicer** **Standard Automatic Correctional Package**

**Model: S13A-15**

01/26/2026 Rev. AD

IMPORTANT!

TO EXPEDITE SHIPMENT OF PARTS, ALWAYS SPECIFY MODEL, REV,  
PART NUMBER, AND SERIAL NUMBER OF UNIT.

### **GLOBE FOOD EQUIPMENT COMPANY**

2215 East River Road  
Dayton, Ohio 45439

#### **Parts Department**

Toll Free 1-800-745-6238

E-Mail: [info@globefoodequip.com](mailto:info@globefoodequip.com)

Website: [www.globefoodequip.com](http://www.globefoodequip.com)

Not for resale



# Table of Contents

<b>Description</b>	<b>Page</b>
<a href="#">S13A-15 Knife Drive Assembly Components</a>	4
<a href="#">S13A-15 Index Knob Components</a>	6
<a href="#">S13A-15 Base Shroud Components</a>	8
<a href="#">S13A-15 Gauge Plate Components</a>	10
<a href="#">S13A-15 Auto Engage Lever Components</a>	12
<a href="#">S13A-15 Index Slide Assembly Components</a>	14
<a href="#">S13A-15 Ring Guard Assembly Components</a>	16
<a href="#">S13A-15 Electrical Base Components</a>	18
<a href="#">S13A-15 Knife Drive Motor Components</a>	22
<a href="#">S13A-15 Transport Arm Assembly Components</a>	24
<a href="#">S13A-15 Automatic Drive Assembly Components</a>	28
<a href="#">S13A-15 Automatic Lift Lever Base Components</a>	30
<a href="#">S13A-15 Carriage and End Weight Assembly Components</a>	32
<a href="#">S13A-15 Knife and Knife Cover Components</a>	34
<a href="#">S13A-15 Grit Sharpener Assembly Components</a>	36
<a href="#">S13A-15 Dummy Sharpener Assembly</a>	38
<a href="#">S13A-15 Wiring Schematic</a>	40



# S13A-15 Knife Drive Assembly Components

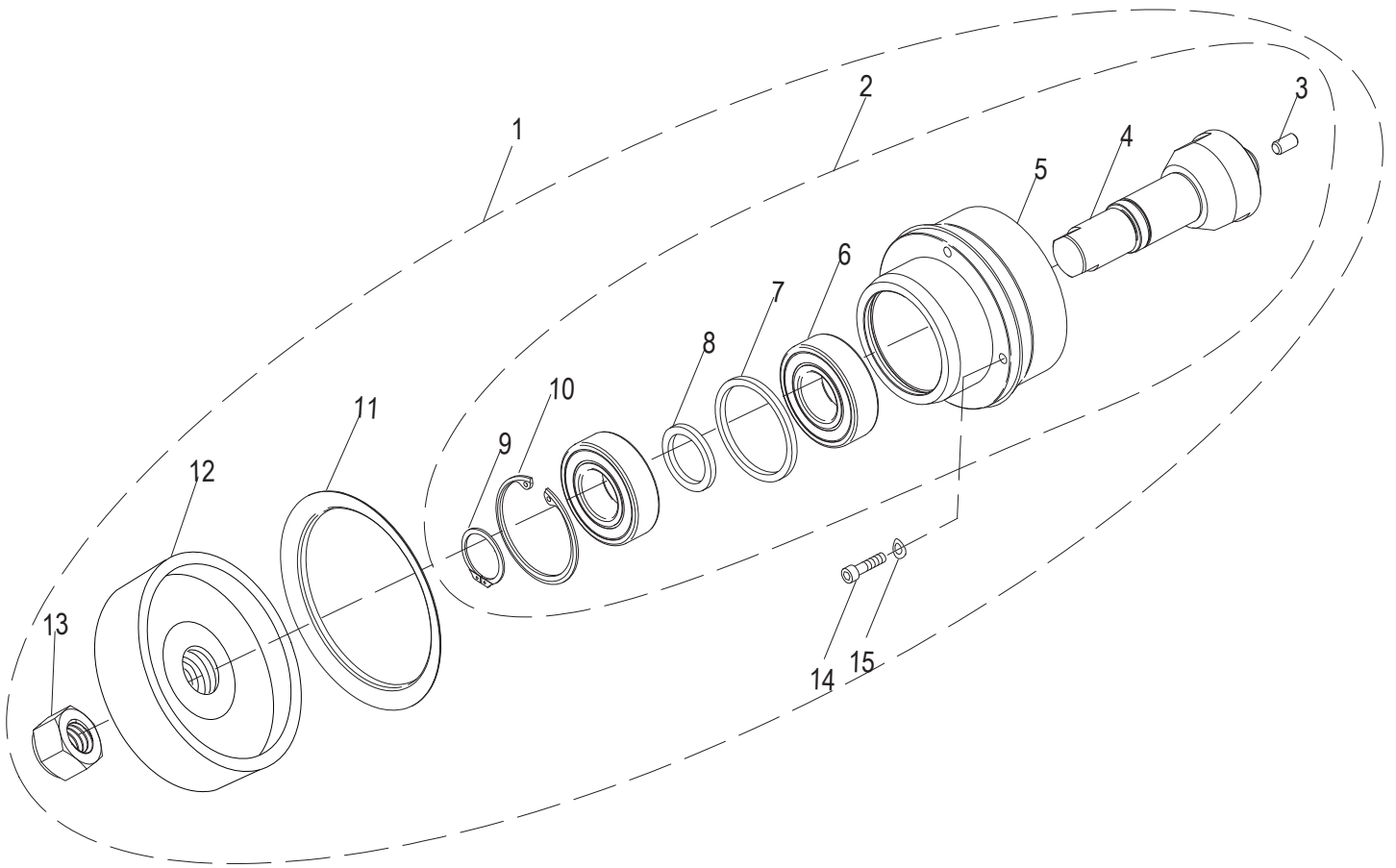



## S13A-15 Knife Drive Assembly Components

Item	Part Number	Description	Qty	Serial Number
1	450211	Knife Drive Assembly (Incl. items 2-15)	1	
2	420088	Knife Drive Bearing Assembly (Incl. items 3-10)	1	
3	510078	Knife Cover Bumper	1	
4	450102	Shaft, Knife Drive	1	
5	450215	Knife Drive Bearing Mount	1	
6	820045-02	Ball Bearing, Sealed	2	
7	450119	Outer Ring, Bearing Spacer	1	
8	450118	Inner Ring, Bearing Spacer	1	
9	800010	Retaining Ring 5101-98 Bowed External	1	
10	810427	Retaining Ring N5002-200	1	
11	520244	Knife Drive Boot	1	
12	450115	Knife Drive Pulley	1	
13	510033	Hex Nut, 7/8-20 Zinc	1	
14	810229	Socket Head Cap Screw 1/4-20x0.75	4	
15	810275	Spring Washer, 1/4x0.5	4	



# S13A-15 Index Knob Components

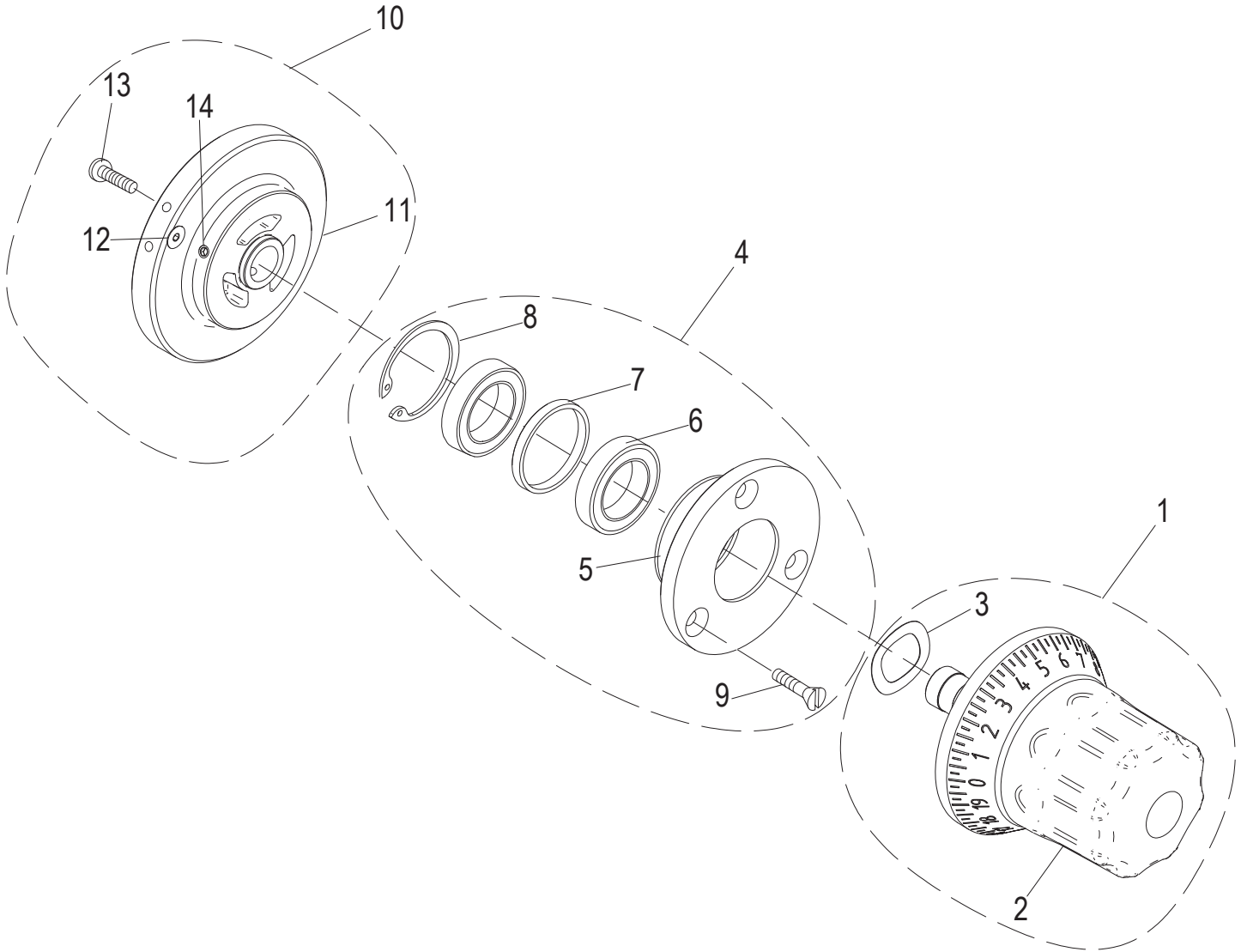



## S13A-15 Index Knob Components

Item	Part Number	Description	Qty	Serial Number
1	500044	Index Knob Kit (Incl. items 2-3)	1	
2	500022	Index Knob	1	
3	800136	Index Knob Tension Spring	1	
4	450214	Index Bearing Hub Assembly Kit (Incl. items 5-9)	1	
5	450150	Index Knob Bearing Hub	1	
6	800011	Ball Bearing 20x32	2	
7	450069	Spacer, Index Bearing	1	
8	800031	Internal Beveled Retaining Ring 1.388	1	
9	800104	Mach. Screw #10-24x5/8 Flat Hd Slotted	3	
10	500050	Index Cam Kit (Incl. items 11-16)	1	
11	520350	Index Cam	1	
12	800105	Socket Cap Screw #10-32x5/8 Button-Hd	1	
13	800160	Socket Cap Screw #10-32x3/4 Flat Hd (SS)	1	
14	810463	Set Screw, Knurl Grip Cup Pt 1/4-28x3/4 (SST)	3	



# S13A-15 Base Shroud Components

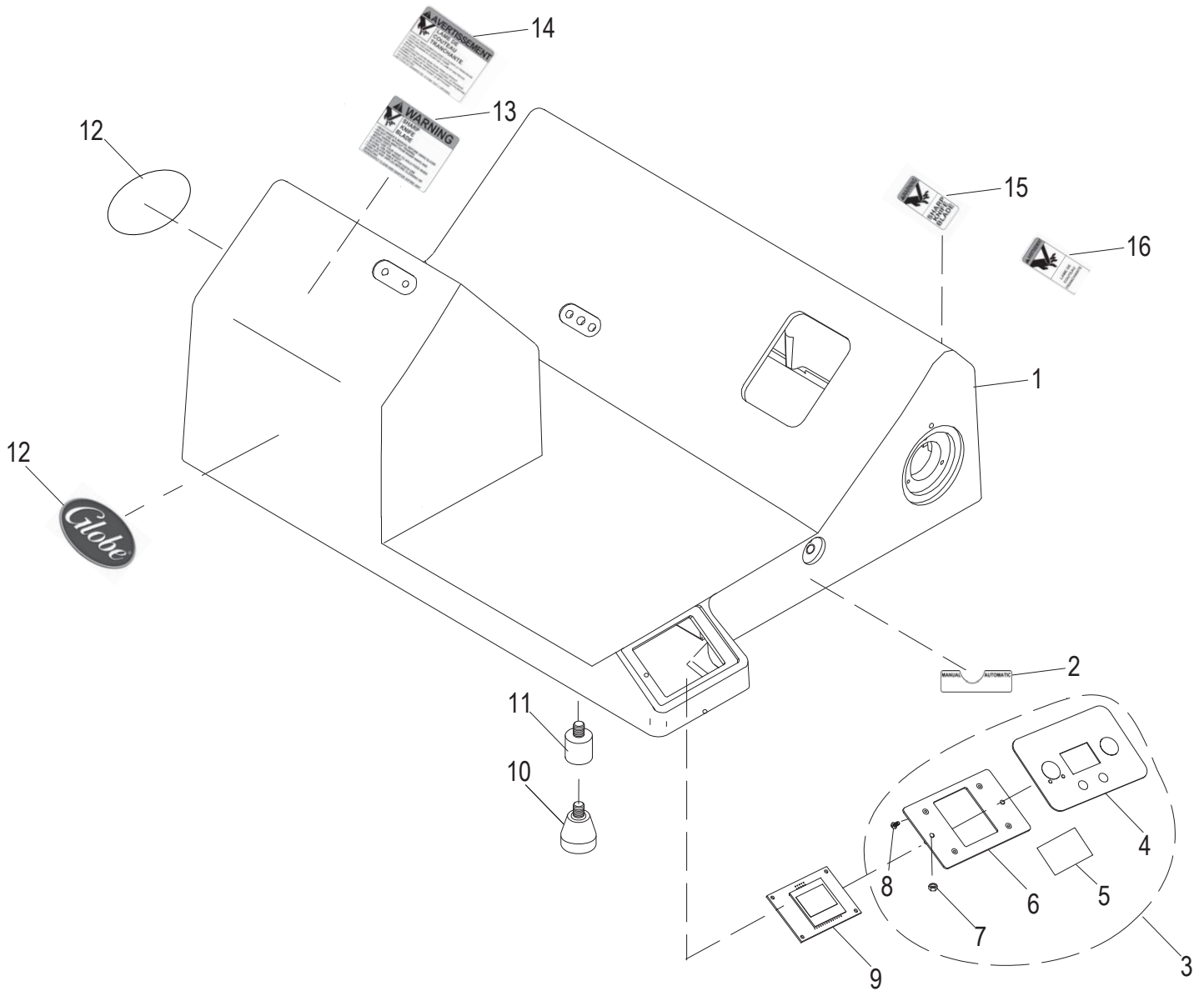



## S13A-15 Base Shroud Components

Item	Part Number	Description	Qty	Serial Number
1	450161-02	Slicer Base	1	
2	920203	Auto Engage Label	1	
3	121072-01	Membrane Switch Kit (Incl. items 4-8)	1	
4	910193	Membrane Switch, Automatic Slicer	1	
5	910088	Pad, Alcohol Prep	1	
6	300092	User Interface Panel, Smart/Auto	1	
7	810422	Nylon Locknut 6-32	2	
8	810423	Phillips Pan Head Screw 4-40 x 0.25"	4	
9	121062	Display Assembly	1	
10	510031	Slicer Foot	4	
11	400158	Foot Extension	4	
12	920202	Globe Logo Decal S - Series	2	
13	920200	Warning Label, Large	1	
14	920198	Warning Label, Large French	1	
15	920201	Warning Label, Small	1	
16	920199	Warning Label, Small French	1	



**S13A-15 Gauge Plate Components**

---

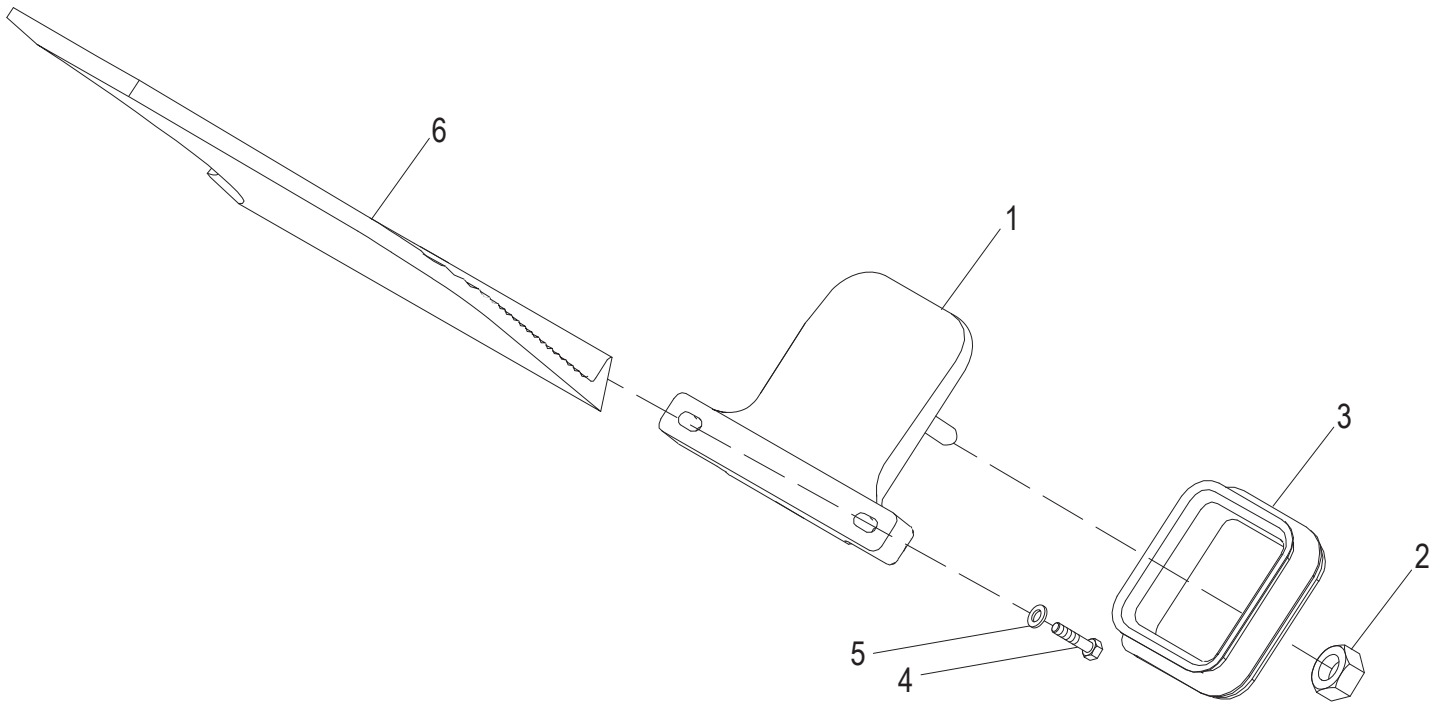



## S13A-15 Gauge Plate Components

---

Item	Part Number	Description	Qty	Serial Number
1	450212	Gauge Plate Base Assembly	1	
2	450054	Post Nut, Gauge Plate Ball Joint	1	
3	500001	Gauge Plate Seal	1	
4	890411	Cap Screw 3/8-16x1-1/2, Hex Hd with Nylon Patch	2	
5	810228	Flat Washer, fits 3/8 Screw, .885 OD	2	
6	450070	Gauge Plate	1	



# S13A-15 Auto Engage Lever Components

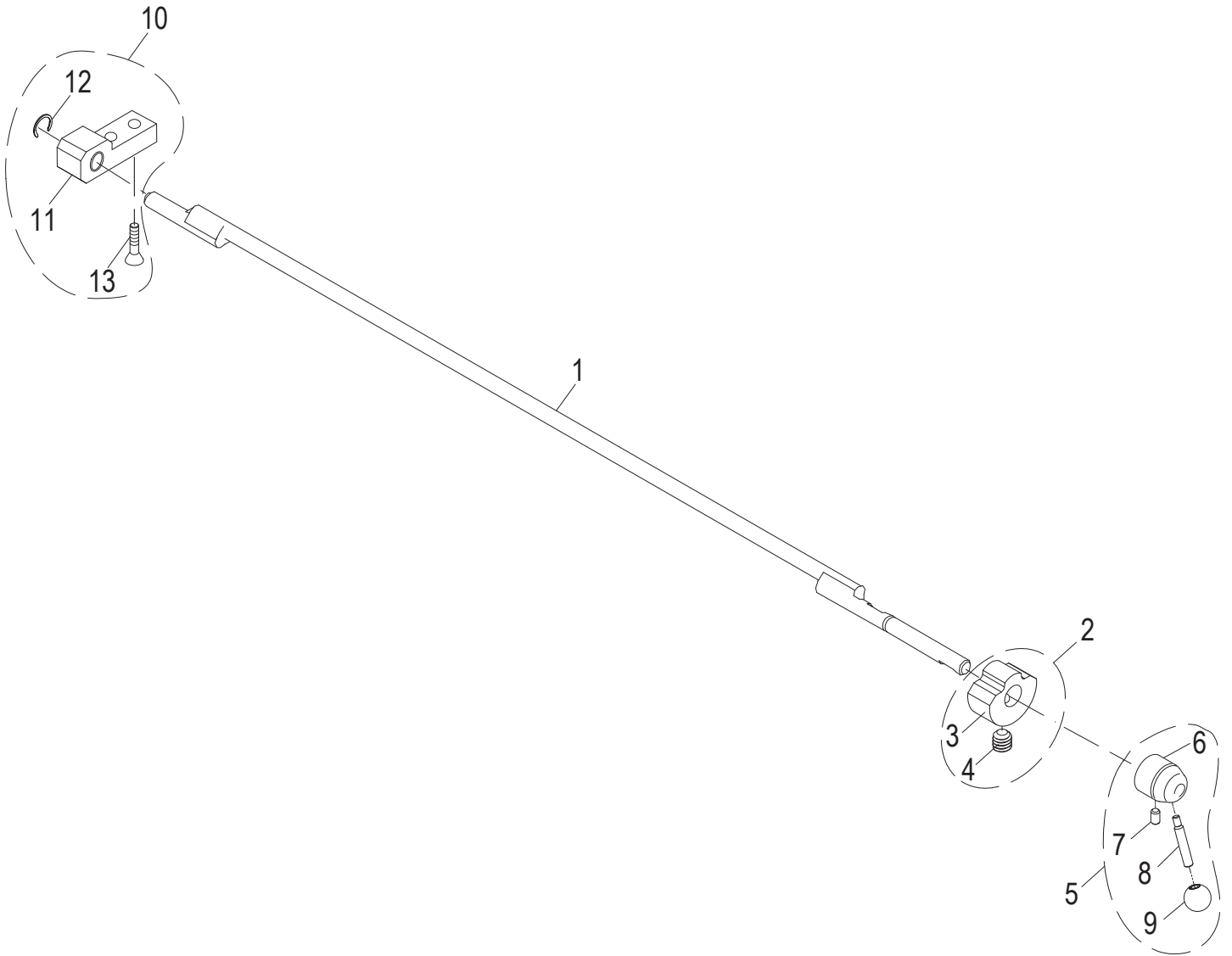



## S13A-15 Auto Engage Lever Components

Item	Part Number	Description	Qty	Serial Number
1	400021	Auto Engage Assembly Bar	1	
2	400038	Position Block Assembly (Incl. items 3-4)	1	
3	400024	Auto Engage Position Block	1	
4	810364	Socket Set Screw 1/4-20x1/4, 18-8 Cup Pt. (SST)	1	
5	500029	Auto Engage Lever Assembly (Incl. items 6-9)	1	
6	500028	Auto Engage Lever Hub	1	
7	810253	Slotted Cup Point Set Screw 1/4-20 x .42	1	
8	400039	Handle Shaft	1	
9	1202	Knob	1	
10	400126	Bearing Block Assembly Kit (Incl. items 11-13)	1	
11	400009	Bearing Block Assembly	1	
12	810429	External Retaining Ring 0.25x0.042	1	
13	810003	Screw 1/4-20x3/4 Crossed Rec., Flat Hd, Tapping	2	



# S13A-15 Index Slide Assembly Components

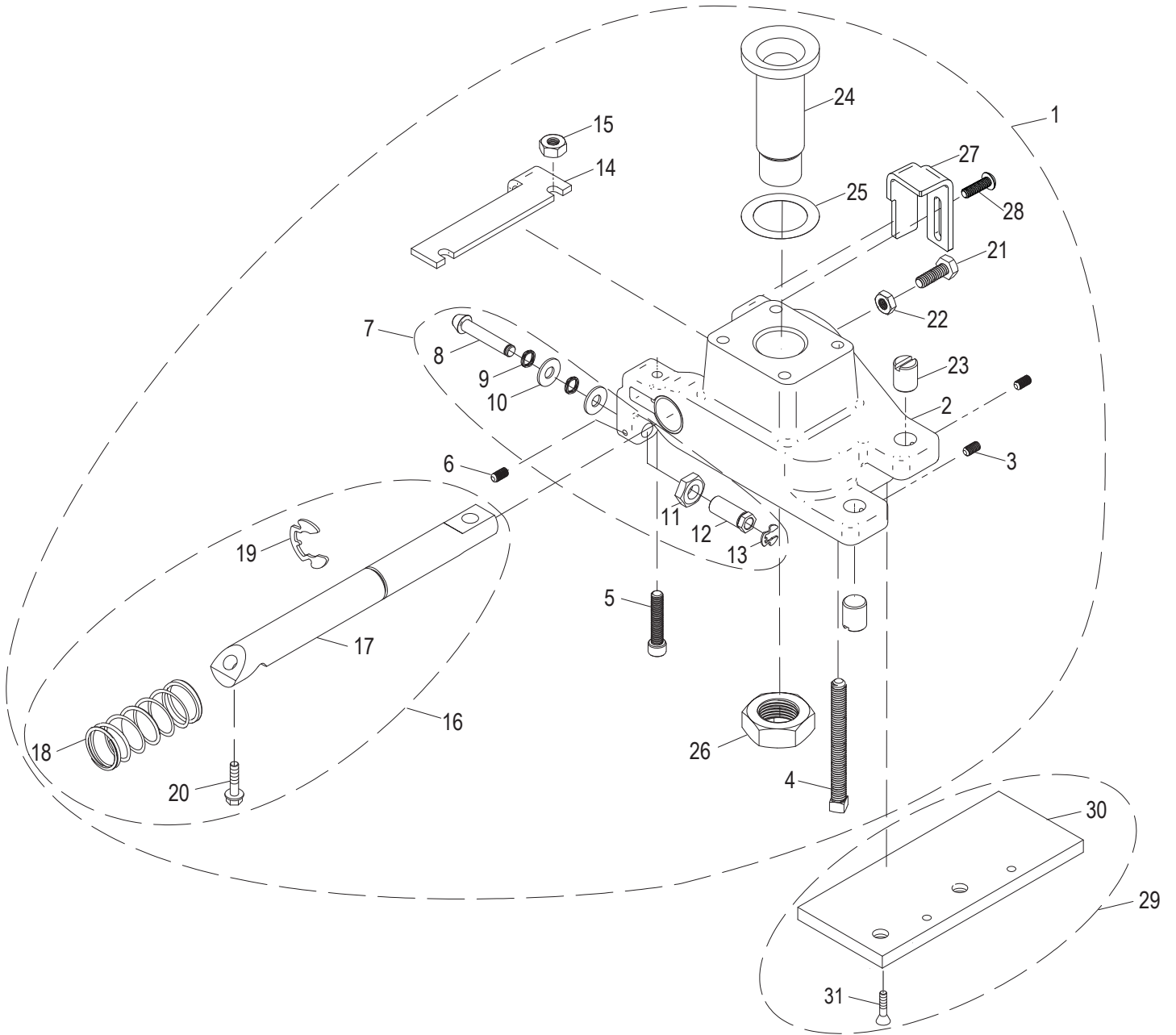



## S13A-15 Index Slide Assembly Components

Item	Part Number	Description	Qty	Serial Number
1	400140	Index Slide Kit (Incl. items 1-28)	1	
2	430028	Index Slide with Bushings	1	
3	810400	Set Screw #10-32x3/8 Cup Pt.	2	
4	800146	Set Screw 5/16-18x3 Sq. Hd Cup Point	4	
5	800144	Cap Screw 1/4-28x1-1/4 Socket Hd	2	
6	800091	Hex Socket Knurl-Cup Point Set Screw 8-32 X 0.1875"	1	
7	400121	Cam Follower Kit (Incl. items 8-13)	1	
8	450153	Follower	1	
9	800163	Wave Spring Cam Follower	2	
10	810410	Flat Washer 0.266x0.625	1	
11	810430	Jam Nut 3/8-24	1	
12	450152	Follower Adjustment Post	1	
13	810379	Retaining Clip Ring 5304-18	1	
14	300153	Stop Plate, Tilt Back	1	
15	800145	Nut 1/4-28 Hex	2	
16	400122	Index Slide Shaft Kit (Incl. items 17-20)	1	
17	450058	Index Slide Shaft	1	
18	800154	Index Spring	1	
19	800152	Retaining Ring (Klipring) 5304-75	1	
20	800058	Washer 5/16-18-1 Hex Hd Tapping Screw	2	
21	810431	Hex Head Screw 1/4-20x0.75	1	
22	810432	Jam Nut 1/4-20	1	
23	450057	Screw, Anti-Rotation	2	
24	450050	Ball Joint Rest	1	
25	800168	Gauge Plate Spacer Kit (Kit of 4)	1	
26	800043	Nut 7/8-14 UNF Hex Jam	1	
27	300154	Adjustment Stop	1	
28	800105	Socket Cap Screw #10-32x5/8 Button-Hd	2	
29	400128	Anti-Rotation Plate Kit (Incl. items 29-31)	1	
30	450056	Anti-Rotation Plate	1	
31	810003	Screw 1/4-20x3/4 Crossed Rec., Flat Hd, Tapping	2	



# S13A-15 Ring Guard Assembly Components

Item 1  
Ring Guard  
Assembly

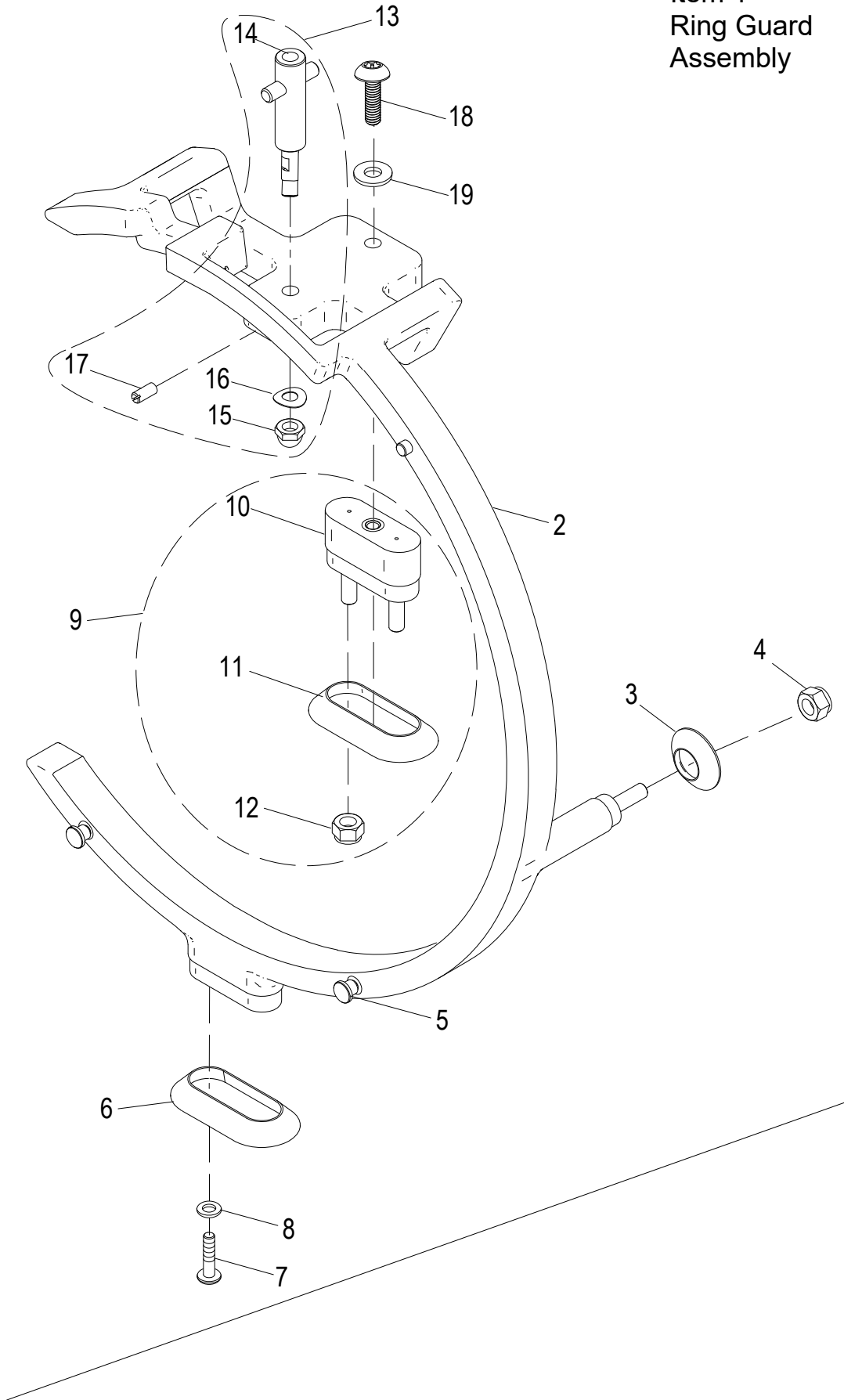



## S13A-15 Ring Guard Assembly Components

Item	Part Number	Description	Qty	Serial Number
1	510085	Ring Guard Assembly (Incl. items 2-19)	1	
2	520316	Ring Guard	1	
3	520243	Round Boot, Ring Guard	1	
4	810438	Nylon Insert Lock Nut 1/4-20	1	
5	450130	Locator Pin	2	
6	520242	Oval Boot, Ring Guard	1	
7	810358	Slotted Truss Head Screw 1/4-20 x 1.00	2	
8	810345	Flat Washer, 1/4 x 0.63	1	
9	450213	Ring Guard Spacer Kit (Incl. items 10-12)	1	
10	460064	Spacer, Ring Guard	1	
11	520242	Oval Boot, Ring Guard	1	
12	810438	Nylon Insert Lock Nut 1/4-20	2	
13	460070	Sharpener Mount Assembly Kit (Incl. items 14-17)	1	
14	450181	Sharpener Mount Assembly	1	
15	800185	Acorn Nut, 1/4-28	1	
16	800184	Spring Washer 0.26x0.55x0.015	1	
17	810483	Slotted Set Screw, #10-32x0.50	1	
18	810374	Mach. Screw 1/4-20x1, Torx	1	
19	810345	Flat Washer, 1/4 x 0.63	2	



# S13A-15 Electrical Base Components

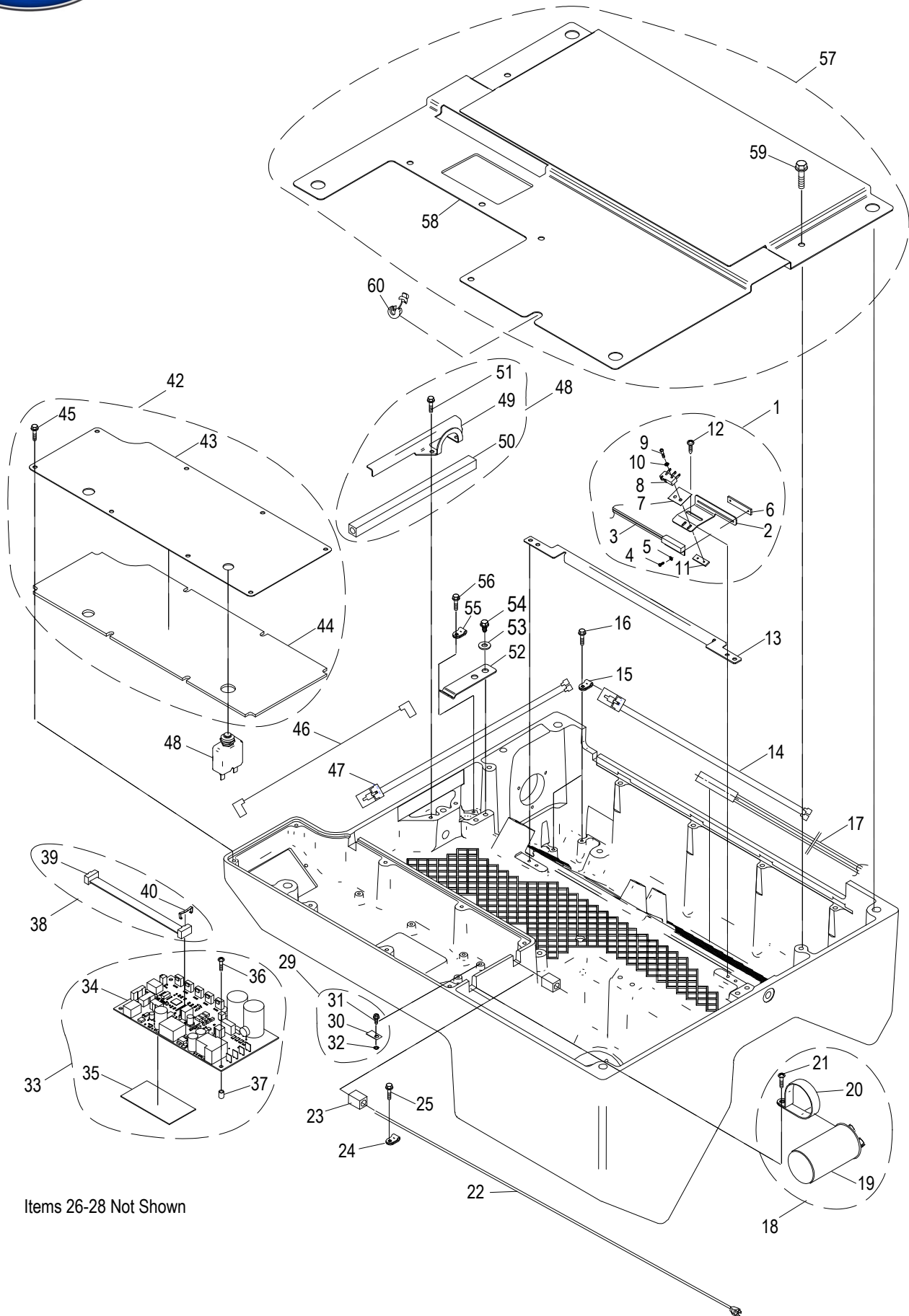



## S13A-15 Electrical Base Components

Item	Part Number	Description	Qty	Serial Number
1	121084-02	Cut/Auto Sensor Kit (Incl. items 2-12)	1	
2	310204	Cut/Auto Engage Sensor Mount	1	
3	110111	Sensor, Reed Switch, Cut Sensor	1	
4	800101	Mach. Screw #1-64x1/4, 18-8 Pan Hd. Phillips (SST)	2	
5	800098	Lock Washer #2 Internal Tooth	2	
6	300056	Nut Plate	1	
7	140125	Micro Switch Insulator	1	
8	110223	Micro Switch, Pin Action	1	
9	800126	Mach. Screw #2-56x7/16 Pan Hd. Phillips	2	
10	800098	Lock Washer #2 Internal Tooth	2	
11	300055	Nut Plate	1	
12	800069	Phillips Round Head Thread Forming Screw 8-32 x 0.375"	4	
13	310208	Inner Wireway Cover	1	
14	100122	Wiring Harness, Automatic Switch	1	
15	110226	Clamp, Nylon Loop	2	
16	800069	Phillips Round Head Thread Forming Screw 8-32 x 0.375"	2	
17	110107	Harness, Reed Switch, Knife Cover Sensor	1	
18	121082-01	120V Capacitor Kit (Incl. items 19-21)	1	
19	140015	Capacitor, Knife Motor 120V	1	
20	110228	Capacitor Clamp (120V)	1	
21	800069	Phillips Round Head Thread Forming Screw 8-32 x 0.375"	1	
18	121082-02	220V Capacitor Kit (Incl. items 18-21) Not Shown	1	
19	140016	Capacitor, Knife Motor (220V) Not Shown	1	
20	110229	Capacitor Clamp (220V) Not Shown	1	
21	800069	Phillips Round Head Thread Forming Screw 8-32 x 0.375" Not Shown	1	
22	130225	Power Supply Cord, 120VAC, 15A	1	
23	510045-01	Sleeve, Large Diameter Wire	2	
24	110227	Power Cord Strain Relief	1	
25	800057	Screw 1/4-20x.75 Hex Washer Hd Tapping	1	
26	130008-01	Power Cord (220V/50Hz) Not Shown	1	
27	130226	Power Supply Cord Not Shown	1	
28	130228	Male Power Plug, Europe CEE7/7, 50Hz Not Shown	1	
26	130008-02	Power Cord (220V/60Hz) Not Shown	1	
27	130226	Power Supply Cord Not Shown	1	
28	130227	Three Blade Male Plug, NEMA 3-15, 60Hz Not Shown	1	
29	121080	Ground Location Tab Kit (Incl. items 30-32)	1	
30	910184	Tab, Ground Location	1	
31	800202	Green Slotted Hex Washer Head Screw #8-32 x 0.312	1	
32	800115	External Tooth Lock Washer #8x0.381	1	
33	121088-01	Control Board Kit (Incl. items 34-37)	1	
34	121061-01	Control Board Assembly	1	
35	510050	Thermal Pad	1	
36	800175	Screw #8-32x3/4 Crossed Recessed Tapping	4	
37	810450	Self Retaining Spacer	4	
38	121081	Ribbon Cable Kit (Incl. items 39-40)	1	
39	100126	Ribbon Cable Assembly Contol To Display Board	1	
40	180126	Retaining Clip, Ribbon Cable	2	
41	140017-01	Circuit Breaker	1	
41	140017-02	Circuit Breaker (220V) Not Shown	1	
42	300063	Electronics Cover & Gasket Kit (Incl. items 43-45)	1	
43	300013	Cover, Electronics	1	
44	500016	Gasket, Electronic Cover	1	
45	810349	Tapping Screw 10 x 1/2 PH, Torx	8	



## S13A-15 Electrical Base Components

---

Item	Part Number	Description	Qty	Serial Number
46	100125	Wire Harness, Circuit Breaker	1	
47	100120	Wiring Harness, Carriage Tilt Sensor	1	
48	300067-02	Front Wireway Cover Kit (Incl. items 49-51)	1	
49	310207	Cover, Front Wireway	1	
50	510045-02	Sleeve, Large Diameter Wire	1	
51	800067	Screw #10-24x1/2 Hex Washer Hd Tapping	2	
52	300019	Auto Engage Position Leaf Spring	1	
53	800079	Flat Washer, 1/4x0.625	4	
54	800057	Screw 1/4-20x.75 Hex Washer Hd Tapping	2	
55	110230	Nylon Loop Clamp 5/16	1	
56	800069	Phillips Round Head Thread Forming Screw 8-32 x 0.375"	1	
57	300068-02	Bottom Cover Assembly (Incl. items 58-59)	1	
58	300139	Bottom Cover	1	
59	810464	Machine Screw 1/4-20 x 1 1/4	2	
60	877	Strain Relief	1	



*INTENTIONALLY LEFT BLANK PAGE*



# S13A-15 Knife Drive Motor Components

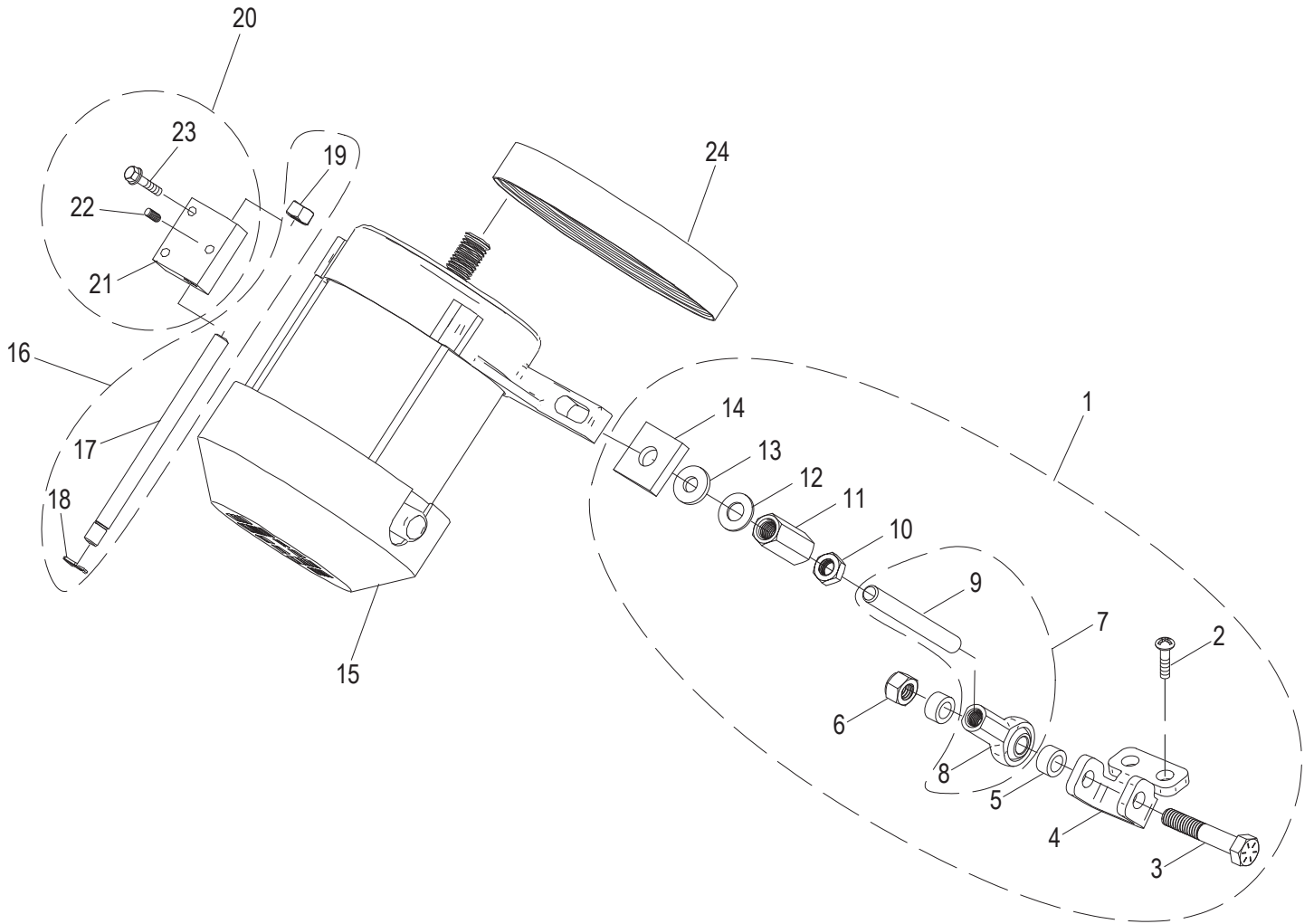



## S13A-15 Knife Drive Motor Components

Item	Part Number	Description	Qty	Serial Number
1	400124	Knife Tensioner Kit (Incl. items 2-14)	1	
2	800135	Thread Forming Screw 1/4-20x5/8 PHP	2	
3	810419	Cap Screw, 5/16-18x1.75 Hx Hd	1	
4	300023	Knife Motor Tensioner Bracket	1	
5	500033	Sleeve Spacer	2	
6	810420	Nylon Insert Locknut 5/16-18	1	
7	400125	Threaded Ball Joint, Knife Tensioner (Incl. items 8-9)	1	
8	800093	Ball Joint Rod End 5/16'-24 Thd	1	
9	450034	Tension Shaft 5/16-24 x 3 Full Thread	1	
10	810414	Nut 5/16-24 UNF Zinc Plated Steel Hex Jam	1	
11	800162	Nut 5/16-24x1 Hex Coupling	1	
12	810416	Flat Washer, 5/16 x 0.69	1	
13	810417	Washer 5/16 Neoprene	1	
14	800161	Washer 5/16 Leveling	1	
15	120158-01	Knife Drive Motor, Single Phase, 120V, 60Hz	1	
15	120158-02	Knife Drive Motor, Single Phase, 220V, 60Hz Not Shown	1	
15	120158-03	Knife Drive Motor, Single Phase, 220V, 50Hz Not Shown	1	
16	400113	Motor Mount Pivot Rod Assembly (Incl. items 17-19)	1	
17	400026	Motor Mount Pivot Rod	1	
18	810429	External Retaining Ring 0.25x0.042	1	
19	810420	Nylon Insert Locknut 5/16-18	1	
20	400123	Motor Pivot Block Kit (Incl. items 21-23)	1	
21	450117	Motor Pivot Block	1	
22	800094	Hex Socket Knurl-Cup Point Set Screw 10-32 x 0.25	1	
23	800068	Washer #10-24x1 Hex Hd Tap. Screw Slotted	2	
24	800092	Knife Drive Belt	1	



# S13A-15 Transport Arm Assembly Components

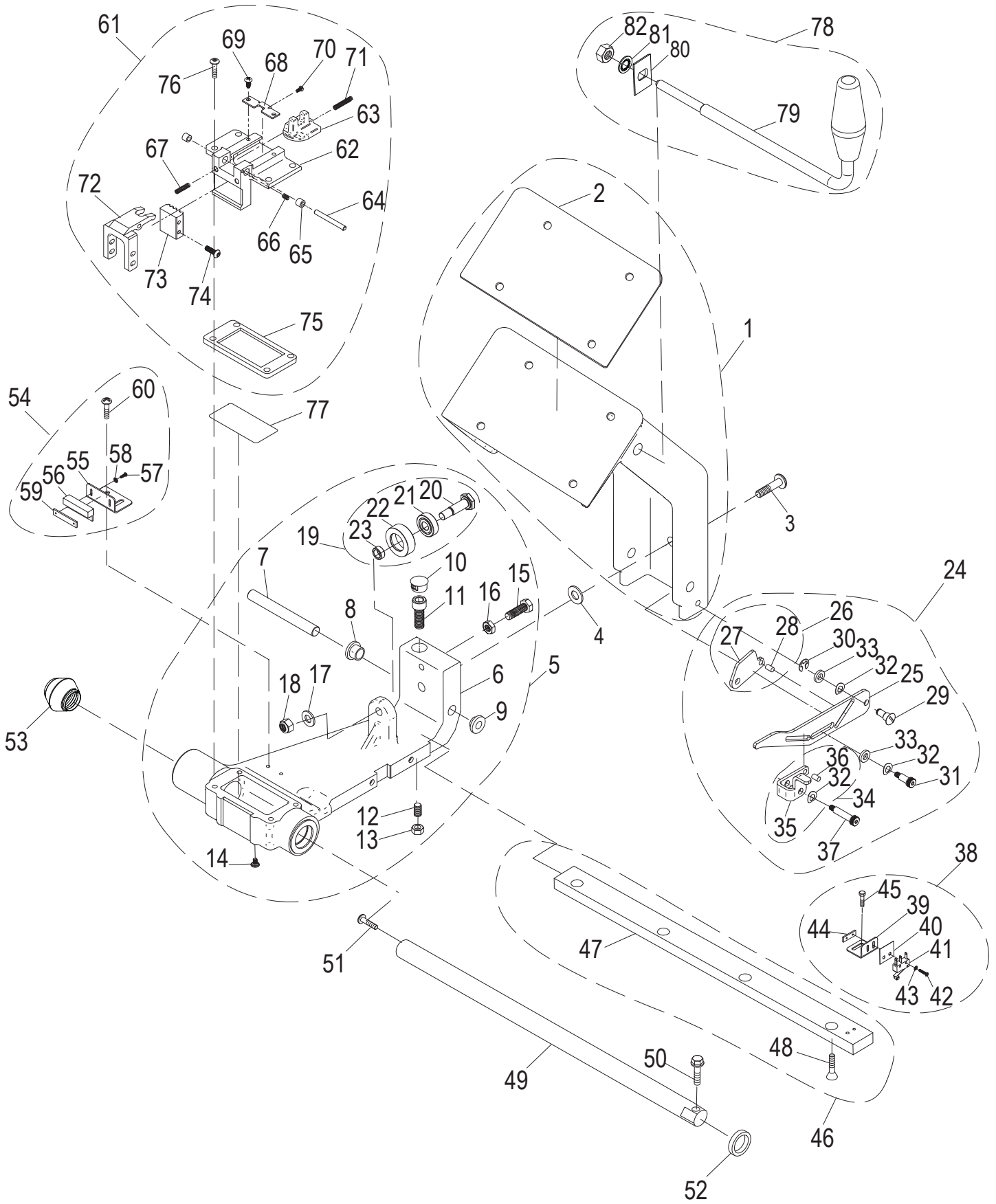



## S13A-15 Transport Arm Assembly Components

Item	Part Number	Description	Qty	Serial Number
1	400129	Carriage Arm & Gasket Kit	1	
2	500004	Carriage Arm Gasket	1	
3	820027	Modified Mach. Screw 3/8-16x1-1/2, Button Hd Torx	1	
4	800149	Captive Knob Retainer	1	
5	400115	Transport Replacement Assembly (Incl. items 6-23)	1	
6	420062	Transport with Bushings	1	
7	400017	Transport Attachment Pin	1	
8	810237	Shoulder Washer .51 IDx.88 Nylon	1	
9	810238	Shoulder Washer .51 IDx1.125 Nylon	1	
10	810227	Dome Plug for 5/8 Hole	1	
11	810256	Socket Hd Cap Screw 3/8-16 x 1 (SST)	1	
12	800015	Transport Tie Down Screw 5/16-24x1.30"	1	
13	800048	Hex Nut 5/16-24	1	
14	810232	Phillips Pan Head Sealing Screw 8-32 x 0.25"	1	
15	810406	Hex Cap Screw 5/16-24x1,18-8 (SST)	1	
16	810414	Nut 5/16-24 UNF Zinc Plated Steel Hex Jam	1	
17	810272	Flat Washer 5/16 x 0.63	1	
18	810420	Nylon Insert Locknut 5/16-18	1	
19	800014	Roller Bearing Assembly (Incl. items 20-23)	1	
20	810351	Roller Bearing Bolt	1	
21	810363	Roller Bearing	1	
22	500003	Bearing Sleeve	1	
23	810352	Spacer Sleeve	1	
24	300069	Transport Interlock Kit (Incl. items 25-37)	1	
25	300049	Transport Slide Lock Plate	1	
26	300057	Lock Plate Assembly (Incl. items 27-28)	1	
27	300050	Lock Plate	1	
28	810451	Dowel Pin, 5/32 x 5/16 (SST)	1	
29	800029	Reverse Shoulder Bolt	1	
30	800082	E-Clip Retaining Ring for 1/4" Shaft	1	
31	810455	Shoulder Bolt 1/4" x 1/2", #10-32 Thread	1	
32	870092	Spring Washer 0.256 x 0.490	3	
33	810459	Washer, Nylon .265 ID, .50 OD, .094 Thick	2	
34	300058	Cam Lock Plate Assembly (Incl. items 35-36)	1	
35	300051	Cam Lock Plate	1	
36	810451	Dowel Pin, 5/32 x 5/16 (SST)	1	
37	810454	Shoulder Bolt 1/4" x 1", #10-32 Thread	1	
38	121089	Carriage Tilt Switch Kit (Incl. items 39-45)	1	
39	310201	Carriage Tilt Back Sensor Mount	1	
40	140125	Micro Switch Insulator	1	
41	110109	Micro Switch	1	
42	800126	Mach. Screw #2-56x7/16 Pan Hd. Phillips	2	
43	800098	Lock Washer #2 Internal Tooth	2	
44	300055	Nut Plate	1	
45	800099	Hex Head Screw #8-32x0.375	2	
46	400131	Transport Roller Bar Kit (Incl. items 47-48)	1	
47	450061	Transport Roller Bar	1	
48	810004	Tapping Screw 1/4-20x1 Cross Rec. FH	4	
49	450060	Transport Shaft	1	
50	800059	Washer 5/16-18x1.25 Hex Hd Tapping Screw	1	
51	810378	Pin-In-Torx Button Head 5/16-18 x 1	1	
52	500005	Transport Bumper	1	
53	800131	Sleeved Spring Assembly	1	



## S13A-15 Transport Arm Assembly Components

Item	Part Number	Description	Qty	Serial Number
54	121090	Carriage Magnet Kit (Incl. items 55-60)	1	
55	310199	Transport Switch Magnet Mount	1	
56	110118	Magnet	1	
57	800101	Mach. Screw #1-64x1/4, 18-8 Pan Hd. Phillips (SST)	2	
58	800098	Lock Washer #2 Internal Tooth	2	
59	300056	Nut Plate	1	
60	800069	Phillips Round Head Thread Forming Screw 8-32 x 0.375"	2	
61	400130	Auto Engage Pickup Kit (Incl. items 62-76)	1	
62	450030	Transport Auto Engage	1	
63	500017	Auto Engage Slide	1	
64	800030	Auto Engage Pivot Dowel	1	
65	500032	Sleeve Bushing	1	
66	810473	Set Screw, 8-32x3/8, Brass Tip Dog Point (SST)	1	
67	800106	Clamp Release Spring	1	
68	300015	Auto Engage Spring Stop Bracket	1	
69	800069	Phillips Round Head Thread Forming Screw 8-32 x 0.375"	1	
70	810423	Phillips Pan Head Screw 4-40 x 0.25"	1	
71	800107	Slide Spring	1	
72	450142	Auto Engage Pivot Lever	1	
73	800105	Socket Cap Screw #10-32x5/8 Button-Hd	1	
74	450146	Auto Engage Belt Clamp	1	
75	510058	Oil Well Gasket	1	
76	800109	Screw 1/4-20x.50 Button Hd Cap	4	
77	800053	Felt Insert	1	
78	400114	Carriage Arm Handle Assembly with Nut (Incl. items 79-82)	1	
79	460076	Carriage Arm Handle	1	
80	400155	Anti Rotation Block	1	
81	810226	Lock Washer, 1/2 Screw Size, Internal Tooth	1	
82	810224	Hex Nut, 1/2-13 Left Hand, Thread	1	



*INTENTIONALLY LEFT BLANK PAGE*



# S13A-15 Automatic Drive Assembly Components

Item 1  
Automatic Drive Kit

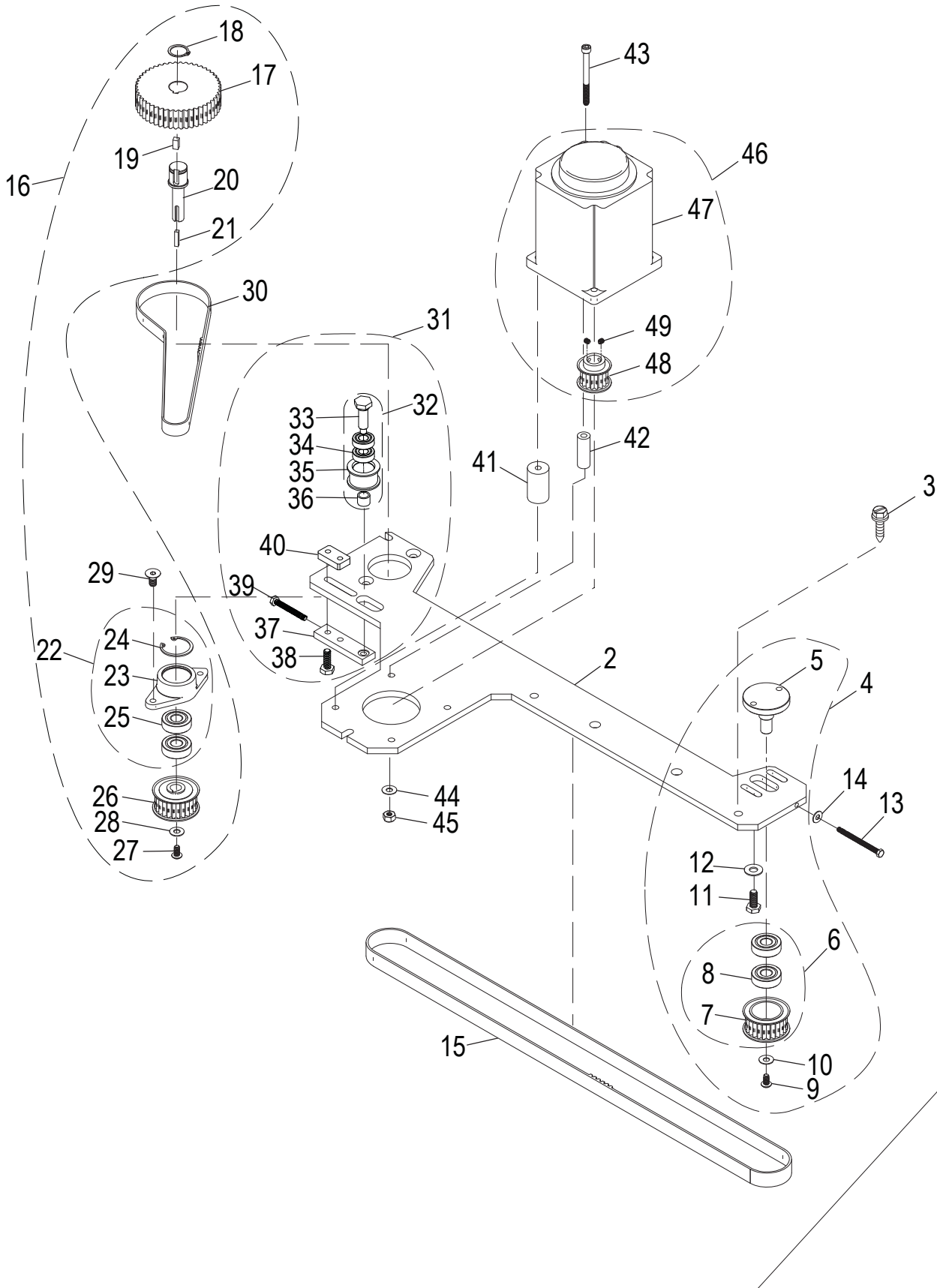



## S13A-15 Automatic Drive Assembly Components

Item	Part Number	Description	Qty	Serial Number
1	400133	Automatic Drive Kit (Incl. items 2-49)	1	
2	450077	Automatic Base Plate	1	
3	800057	Screw 1/4-20x.75 Hex Washer Hd Tapping	4	
4	400143	Idler Assembly Kit (Incl. items 5-12)	1	
5	450080	Pulley Shaft	1	
6	450097	Idler Assembly (Incl. items 7-8)	1	
7	450094	Idler Pulley (24 Tooth)	1	
8	800005	Bearing 6000 Double Seal	2	
9	800077	Hex Socket Button Head Screw #10-24 x 0.375	1	
10	800076	Flat Washer, #10x0.50	1	
11	800072	Hex Head Screw 1/4-20x0.63	2	
12	800079	Flat Washer, 1/4x0.625	2	
13	800088	Mach. Screw #8-32x2 Hex Hd (SS)	1	
14	870072	Flat Washer, #8 x 0.44	1	
15	800008	Automatic Driven Belt	1	
16	400141	48/24 Tooth Drive Pulley Kit (Incl. items 17-29)	1	
17	450099	Drive Pulley (48 Tooth)	1	
18	800090	Retaining Ring 5100-62 External	1	
19	450088	Key, 3/16x3/16 Drive	1	
20	450079	Shaft, Dual Pulley	1	
21	450089	Key, 1/8x1/8 Drive	1	
22	450096	Bearing Block Assembly (Incl. items 23-25)	1	
23	450087	Bearing Block	1	
24	800007	Retaining Ring N5002-102 Internal	1	
25	800005	Bearing 6000 Double Seal	2	
26	450093	Drive Pulley (24 Tooth)	1	
27	800077	Hex Socket Button Head Screw #10-24 x 0.375	1	
28	800076	Flat Washer, #10x0.50	1	
29	800073	Screw 1/4-20x1/2 Socket Flat Countersunk Hd Cap	2	
30	800009	Automatic Drive Belt	1	
31	400154	Belt Tension Kit (Incl. items 32-40)	1	
32	400151	Belt Tensioner Assembly	1	
33	400149	Tension Pulley Shaft	1	
34	800012	Bearing, Tension	2	
35	500059	Tension Sleeve	1	
36	400153	Spacer	1	
37	400152	Tensioner Bar	1	
38	810431	Hex Head Screw 1/4-20x0.75	2	
39	810007	Screw, Machine #10-32x1-1/2 Hx Hd Drive	1	
40	400150	Nut Plate	1	
41	450090	Standoff, Automatic Motor	3	
42	450091	Standoff, Automatic Motor	1	
43	800074	Screw #10-24x2.25 Socket Hd Cap	4	
44	800076	Flat Washer, #10x0.50	4	
45	800075	Nut #10-24 Hex	4	
46	400144	Carriage Drive Motor Kit (Incl. items 46-49)	1	
47	120160	Carriage Drive Motor (BLDC)	1	
48	450095	Motor Drive Pulley (16 Tooth)	1	
49	800091	Hex Socket Knurl-Cup Point Set Screw 8-32 X 0.1875"	2	



# S13A-15 Automatic Lift Lever Base Components

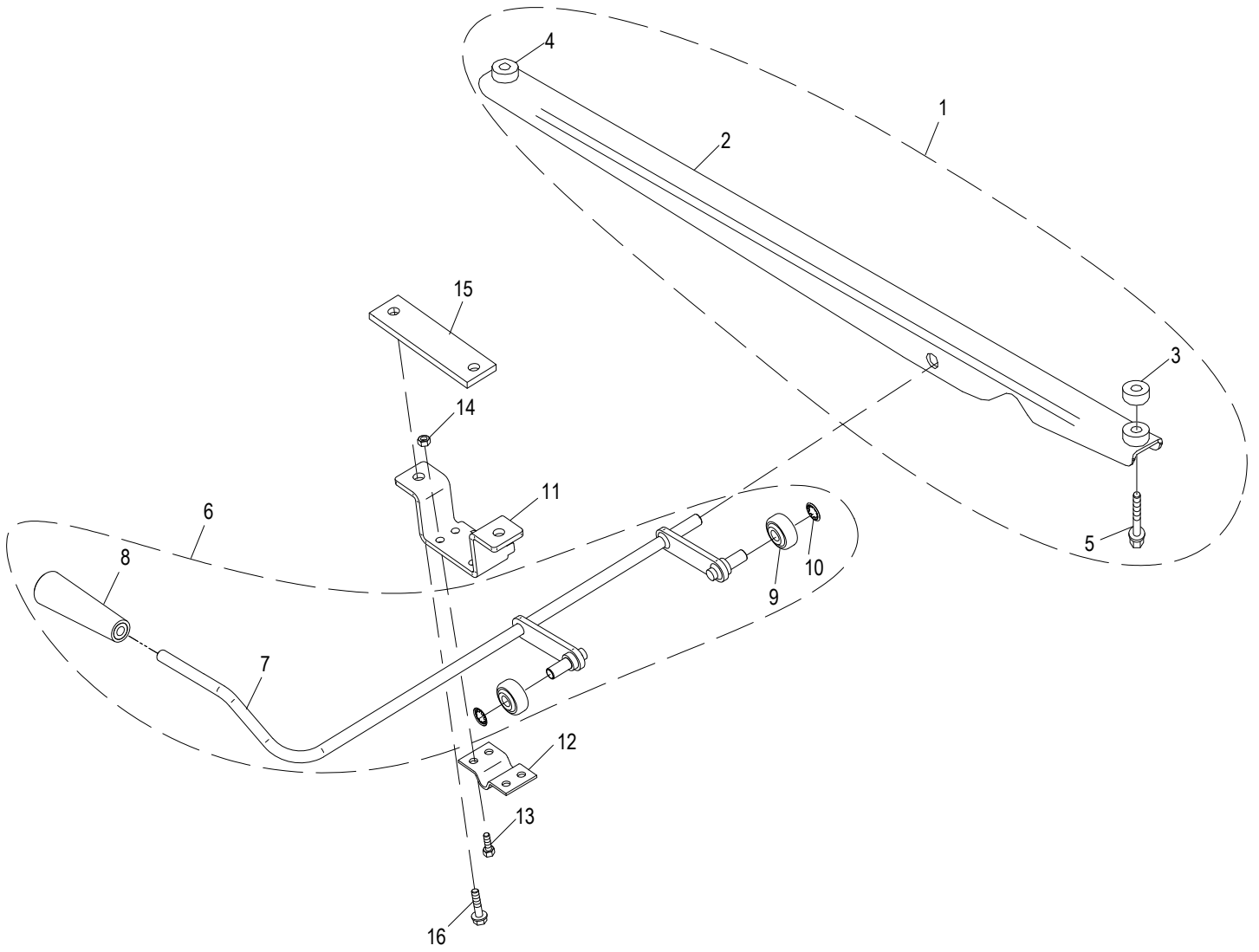



## S13A-15 Automatic Lift Lever Base Components

Item	Part Number	Description	Qty	Serial Number
1	300253	Lift Lever Base Support Kit, Security (Incls. items 2-5)	1	
2	300077	Lift Lever Base Support Assembly	1	
3	400160	Lift Lever Base Support Spacer	2	
4	400037	Lift Lever Base Support Post	2	
5	810464	Machine Screw 1/4-20 x 1 1/4	2	
6	400163	Lift Lever Assembly Kit (Incls. items 7-10)	1	
7	400032	Lift Lever Weldment	1	
8	951-8	Lift Lever Handle	1	
9	400034	Lift Lever Roller	2	
10	800087	Retaining Ring 5115-37 Push-On External	2	
11	300078	Lift Lever Support & Stop	2	
12	300030	Lift Lever Bracket	1	
13	810373	Mach. Screw 1/4-20x5/8 Button Hd Pin-in-Torx	2	
14	810438	Nylon Insert Lock Nut 1/4-20	1	
15	400159	Lift Lever Spacer Plate	1	
16	800059	Washer 5/16-18x1.25 Hex Hd Tapping Screw	2	



# S13A-15 Carriage and End Weight Assembly Components

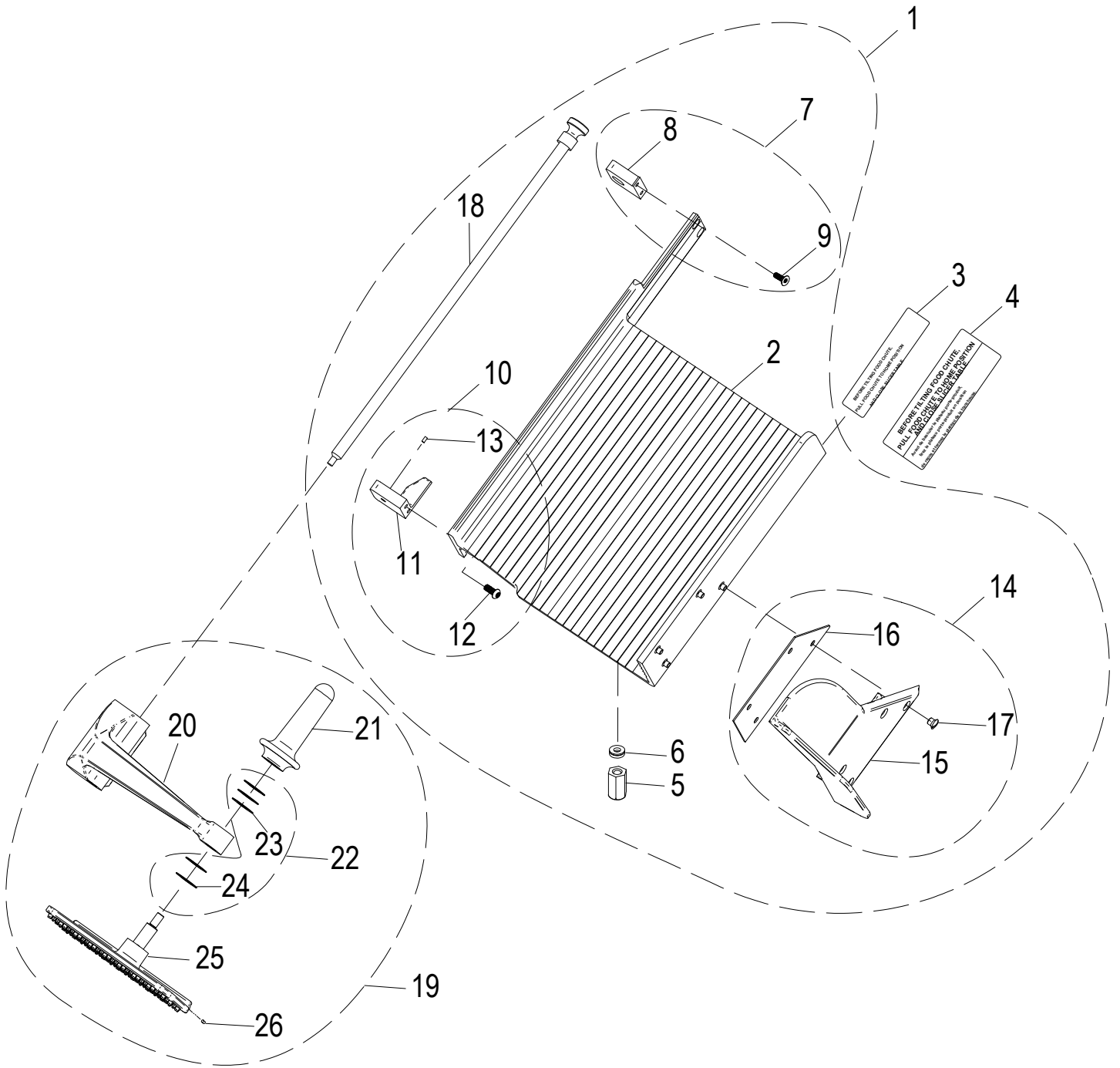



## S13A-15 Carriage and End Weight Assembly Components

Item	Part Number	Description	Qty	Serial Number
1	400138-02	Carriage Assembly Kit (Incl. items 2-18)	1	
2	400012	Carriage Insert Assembly	1	
3	920196	Carriage Tilt Label	1	
4	920197	Carriage Tilt Label (French)	1	
5	800188	Custom Nut, 1/4-20	4	
6	800085	Washer 1/4" Screw, Self Aligning	4	
7	400343	Rod Mount KitEnd Weight, Security (Incl. items 8-9)	1	
8	450156	End Weight Rod Mount	1	
9	810372	Pin-In-Torx Flat Head Screw 1/4-20 x 0.75	2	
10	400344	End Weight Stop Kit, Security (Incl. items 11-13)	1	
11	420094	End Weight Stop	1	
12	810373	Mach. Screw 1/4-20x5/8 Button Hd Pin-in-Torx	2	
13	800205	Stop Pin, Delrin End Weight	1	
14	500167	Thumb Guard Assembly Kit, Security (Incl. items 15-17)	1	
15	510052	Thumb Guard Assembly	1	
16	510038	Carriage Thumb Guard Gasket	1	
17	430054	Thumb Guard Screw, Tamper Proof	4	
18	450197	End Weight Shaft Assembly	1	
19	500027-01	End Weight Assembly (Incl. items 20-26)	1	
20	420065	End Weight Arm Assembly	1	
21	500024	End Weight Handle	1	
22	800164	End Weight Face Washer Kit (Incl. items 23-24)	1	
23	800033-02	End Weight Face Washer	1	
24	800033-01	End Weight Face Washer	4	
25	500007	Molded End Weight Assembly	1	
26	800047	Delrin Pin, 1/8 Dia x 3/8	1	



**S13A-15 Knife and Knife Cover Components**

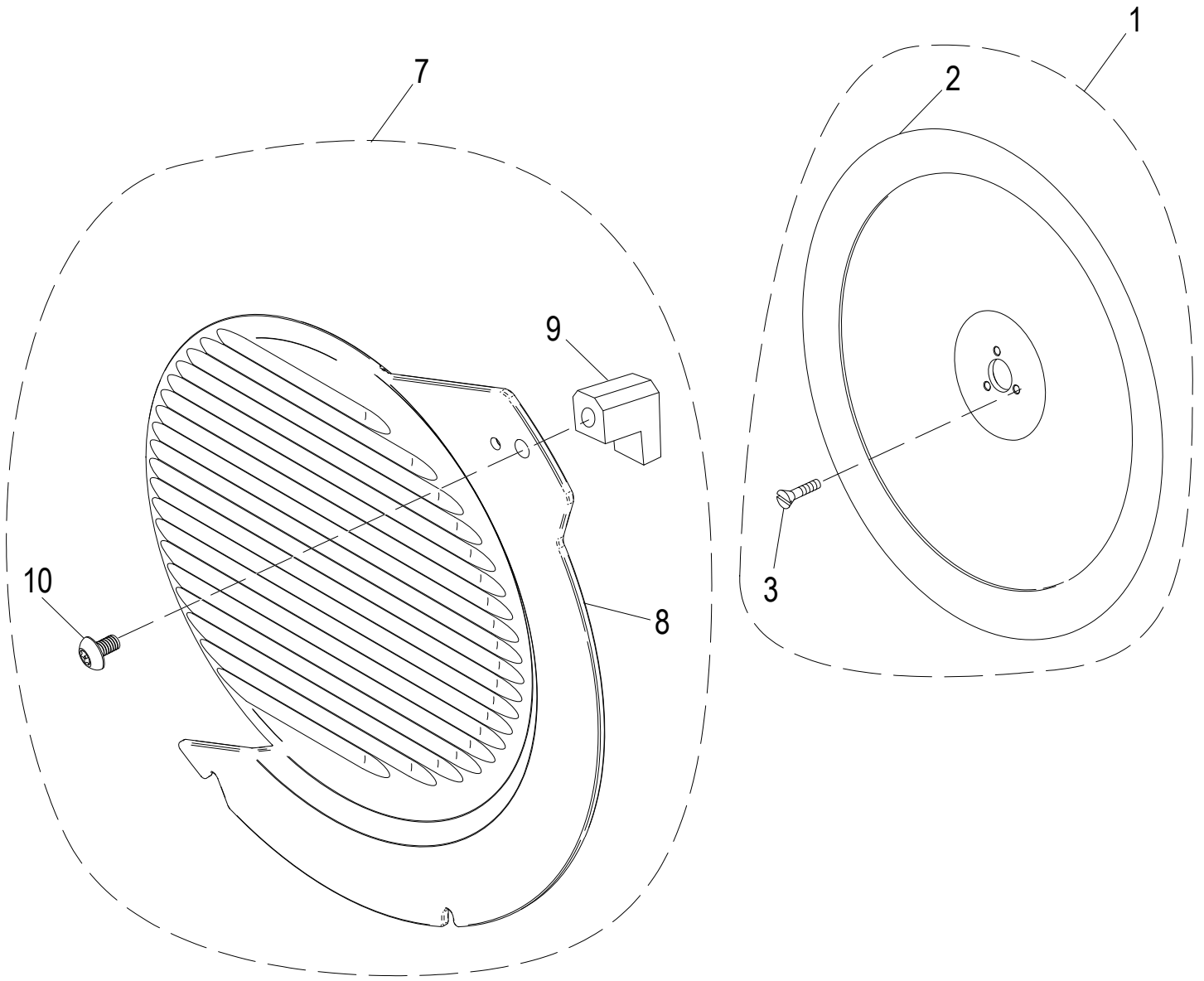

Items 4-6 Not Shown



## S13A-15 Knife and Knife Cover Components

Item	Part Number	Description	Qty	Serial Number
1	400139-03	Security Knife Kit (Incl. items 2-3)	1	
2	450170	13 Inch Steel Knife	1	
3	810368	Pin-In-Torx Flat Head Screw 10-32 x 0.50	3	
4	400161-01	Stainless Steel Knife Kit (incl. items 5-6) Not Shown	1	
5	450171	Knife, 13 inch (SST) Not Shown	1	
6	810274	Slotted Flat Head Screw, 10-32x0.5 Not Shown	3	
7	410055	Knife Cover Assembly, Security Slicer	1	
8	250063	Knife Cover	1	
9	430056	Knife Cover Lock	1	
10	810377	Mach. Screw 5/16-18x3/4 Button Hd Torx	1	



# S13A-15 Sharpener Assembly Components

Item 1  
Grit Sharpener Assembly

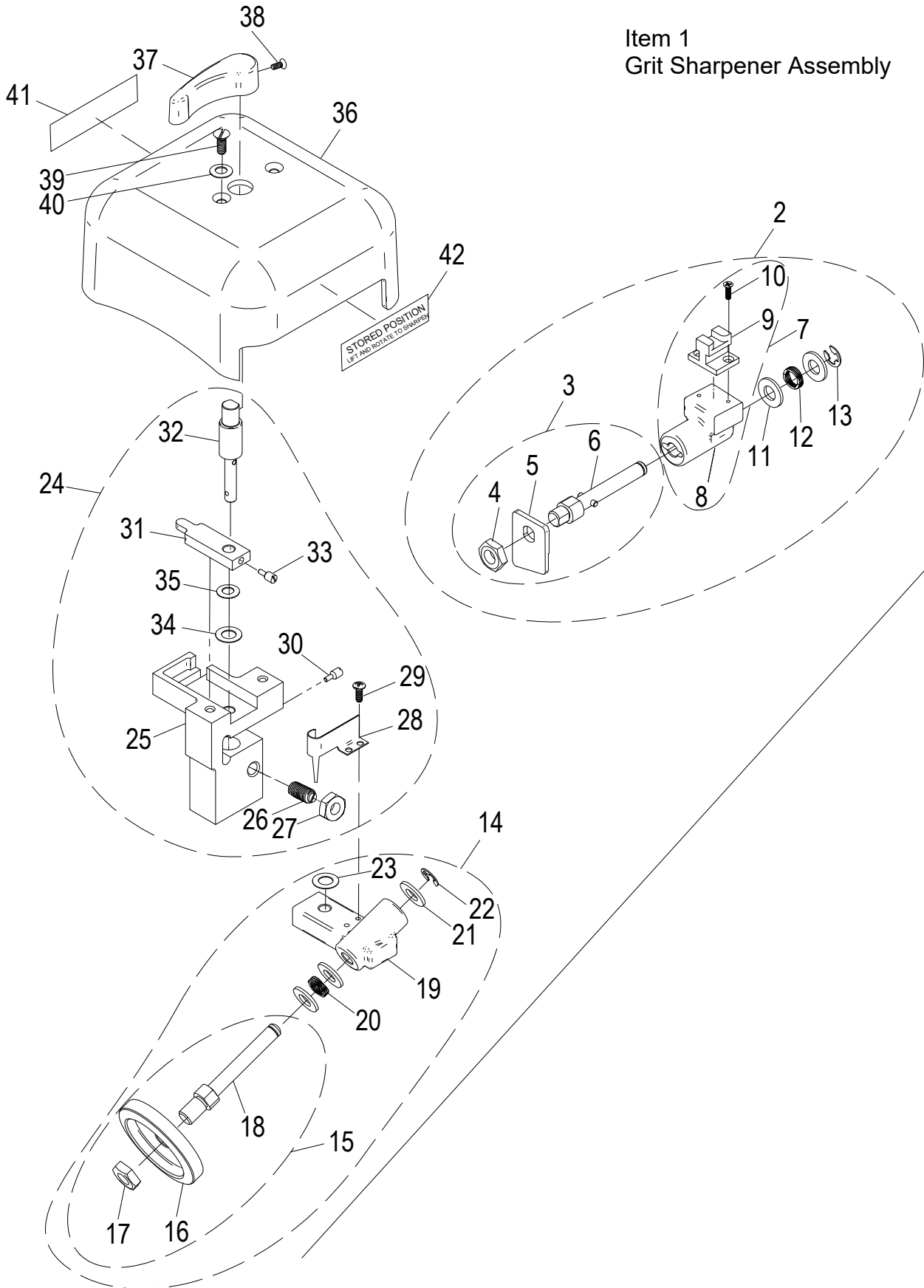



## S13A-15 Sharpener Assembly Components

Item	Part Number	Description	Qty	Serial Number
1	440044-03	Grit Sharpener Assembly (Incl. items 2-41)	1	->S13A-00-001611
2	430051-02	Grit Honing Stone Assembly (Incl. items 3-12)	1	
3	940033-02	Grit Honing Stone Shaft Assembly (Incl. items 4-6)	1	
4	810430	Jam Nut 3/8-24	1	
5	200047	Flat Grit Honing Stone	1	
6	450163	Honing Stone Dowel Assembly	1	
7	400291	Honing Stone Bracket Kit	1	
8	430032	Honing Stone Bracket	1	
9	430042	Honing Stone Slide	1	
10	810222	Phillips Flat Head Screw #4-40 x 0.38	2	
11	810272	Flat Washer 5/16 x 0.63	2	
12	810362	Wave Spring 0.38 x 0.49 x 0.14	1	
13	810273	External Retaining Ring, Type E 0.243 x .50	1	
14	430052-02	Grit Sharpening Stone Assembly (Incl. items 14-22)	1	
15	940044-02	Grit Sharpening Stone Shaft Assembly (Incl. items 15-17)	1	
16	410049	Grit Sharpening Stone	1	
17	810430	Jam Nut 3/8-24	1	
18	460065	Sharpening Stone Shaft	1	
19	430031	Sharpening Stone Bracket	1	
20	810361	Wave Spring 0.37 x 0.49 x 0.15	1	
21	810272	Flat Washer 5/16 x 0.63	3	
22	810273	External Retaining Ring, Type E 0.243 x .50	1	
23	810437	Flat Washer 5/16 x 0.57	1	
24	400137	Sharpener Mount Center Kit (Incl. items 24-34)	1	
25	430045	Sharpener Center Mount	1	
26	810488	Slotted Ball Plunger, 1/4-28 x 0.531	1	
27	810489	Jam Nut 1/4-28	1	
28	310137	Sharpener Return Spring	1	
29	810271	Phillips Pan Head Screw #6-32x0.375	2	
30	810344	Slotted Dog Point Set Screw #10-32 x 0.45	1	
31	430040	Honing Stone Lever	1	
32	400183	Sharpener Handle Shaft	1	
33	810344	Slotted Dog Point Set Screw #10-32 x 0.45	1	
34	810437	Flat Washer 5/16 x 0.57	1	
35	800184	Spring Washer 0.26x0.55x0.015	1	
36	250069	Sharpener Cover	1	
37	510041	Sharpener Handle, Top	1	Refer to Serial Number Document
37	500070	Sharpener Handle, Top	1	Refer to Serial Number Document
38	810233	Mach. Screw 8-32x1/2 Black, Phillips, w/Nylon Patch	1	Refer to Serial Number Document
38	800223	Phillips Flat Head Screw #8-32 x 0.375	1	Refer to Serial Number Document
39	810246	Slotted Truss Head Screw #10-32 x 0.50	2	
40	810279	Spring Washer #10 x 0.42	2	
41	920215	Label, Sharpen Position	1	
42	920216	Label, Stored Position	1	



**S13A-15 Dummy Sharpener Assembly**

Item 1  
Dummy Sharpener Assembly

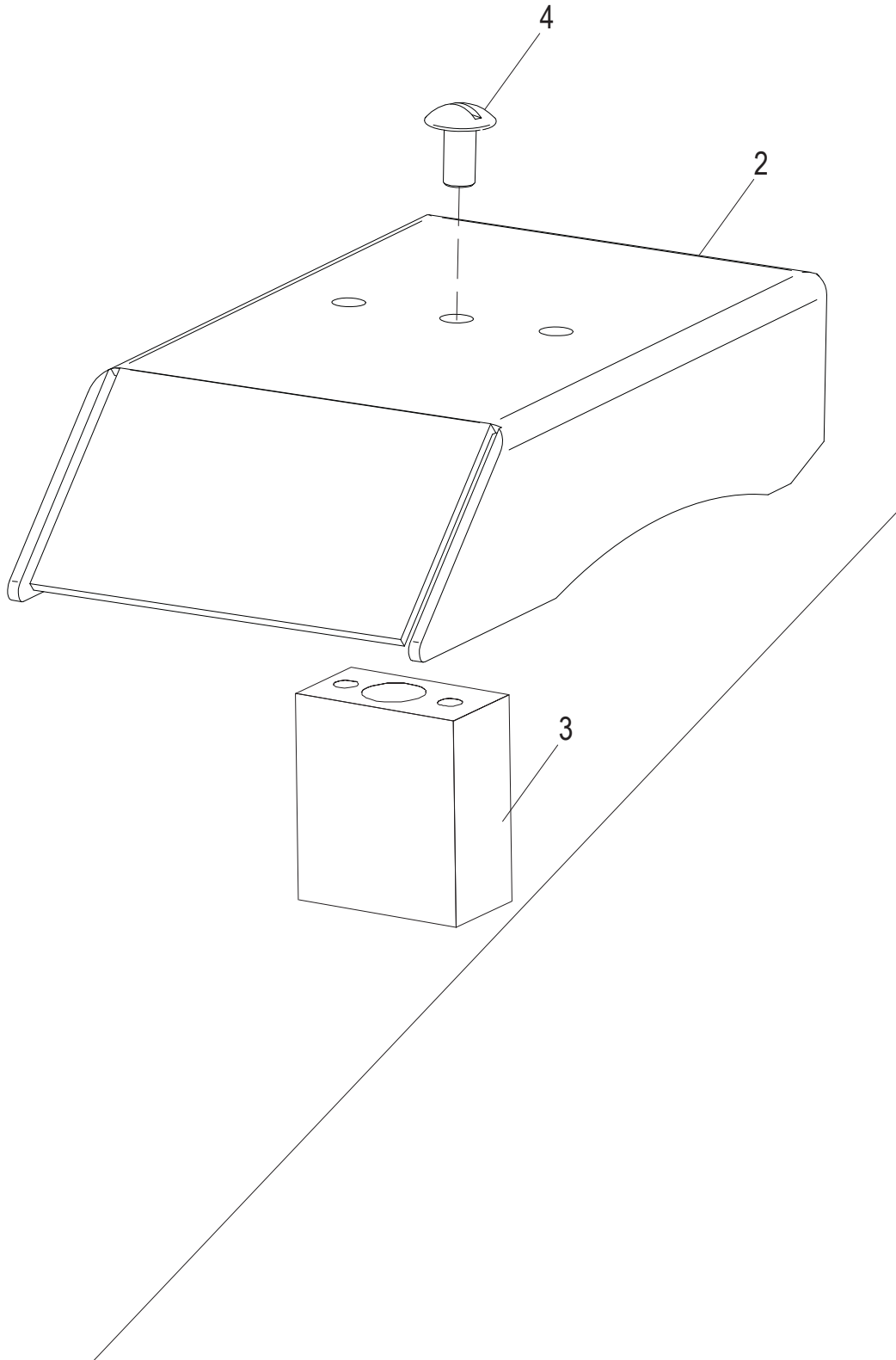



## **S13A-15 Dummy Sharpener Assembly**

---

<b>Item</b>	<b>Part Number</b>	<b>Description</b>	<b>Qty</b>	<b>Serial Number</b>
1	310255	Dummy Sharpener Assembly	1	
2	310244	Dummy Sharpener Top	1	
3	450185	Dummy Sharpener Base	1	
4	810180	Pin-In-Torx Button Head Screw, 1/4-20 x 0.50	3	

