

Parts Catalog



PP4

Patty Press

Model: PP4

06/18/2025 Rev C

IMPORTANT!

TO EXPEDITE SHIPMENT OF PARTS, ALWAYS SPECIFY MODEL, REV,
PART NUMBER, AND SERIAL NUMBER OF UNIT.

GLOBE FOOD EQUIPMENT COMPANY

2215 East River Road
Dayton, Ohio 45439

Parts Department

Toll Free 1-800-745-6238

E-Mail: info@globefoodequip.com

Website: www.globefoodequip.com

Not for resale

Table of Contents

Description

Page

PP4 Patty Press Components

4



PP4 Patty Press Components

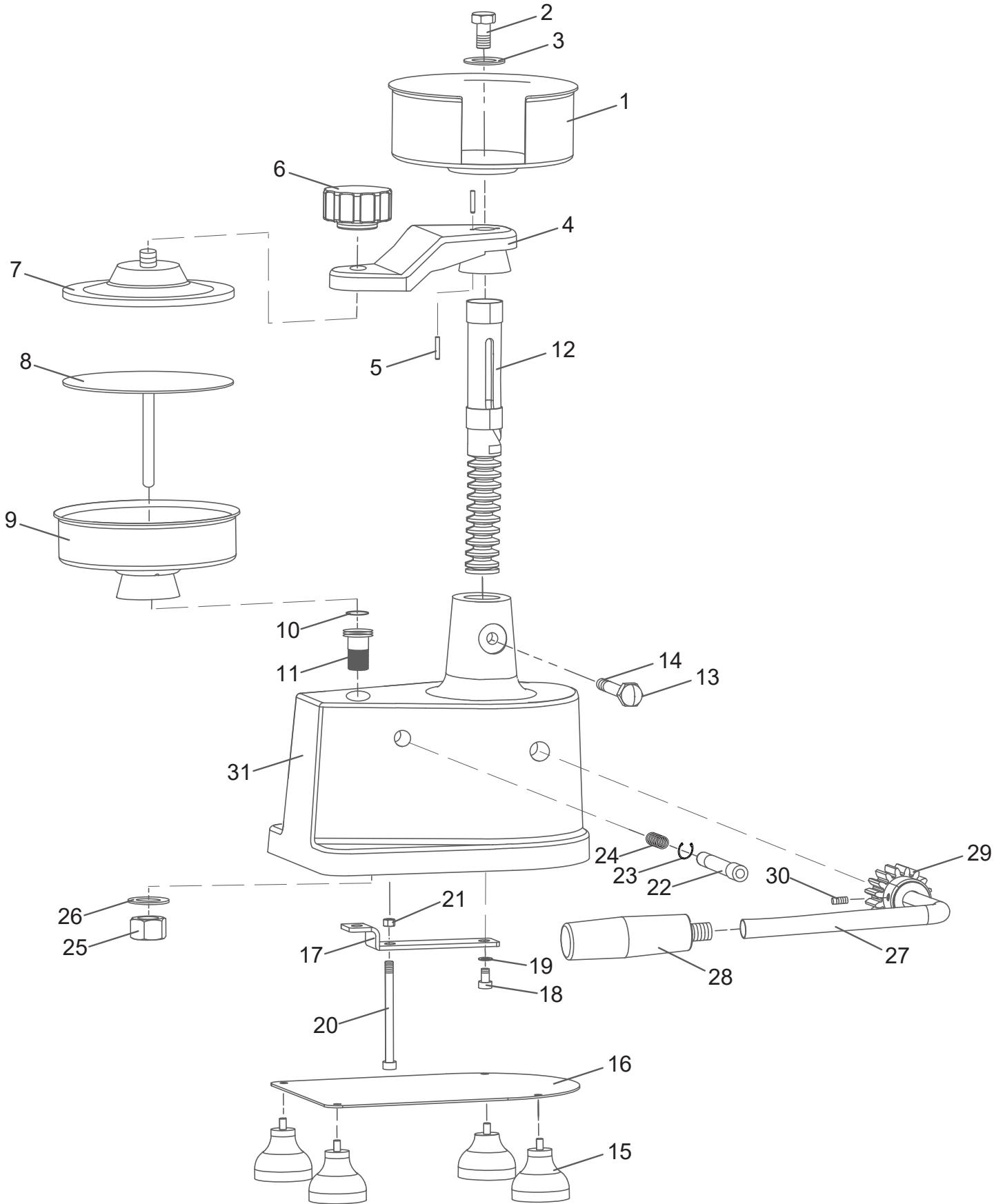



PP4 Patty Press Components

Item	Part Number	Description	Qty	Serial Number
1	N00618	Paper Tray 4"	1	
2	H00607	Hex Head Screw M10x35	1	
3	H00604	Washer M10 Large	1	
4	N00620	Presser Arm	1	
5	N00603	Pin	2	
6	N00608	Presser Knob	1	
7	N00616	Upper Presser 4"	1	
8	N00612	Lower Presser 4"	1	
9	N00614	Food Tray 4"	1	
10	H00605	O-ring Seal 14.75 mm, OD	1	
11	N00625	Food Tray Attachment M16x30, M22x1	1	
12		Presser Arm Shaft	1	
13	H00606	Acorn Nut M10	1	
14	N00609	Bolt	1	
15	N00610	Leg	4	
16		Bottom Board	1	
17	N01262	Board	1	
18	H00021	Cap Screw, Hex Hd Black Oxide	1	
19	M035	Flat Washer ID 6.5 OD 12 TH 1.5 mm Zinc	1	
20	H00621	Hex Head Bolt M6x90	1	
21	M034	Hex Nut M6x1.0 OD 10 mm TH 5 mm Zinc	1	
22	N01263	Push Bar	1	
23	H00602	E-Clip NOM. DIA. 10 mm	1	
24	H02075	Spring	1	
25	H00622	Hex Nut, SS M16x2,OD-24mm, TH-13mm	1	
26	H00624	Washer M16	1	
27		Shaft Handle	1	
28	N00611	Handle	1	
29		Gear	1	
30		Gear Set Screw	1	
31		Body	1	
32	910265	Globe Logo (Not Illustrated)	1	