

Parts Catalog



GEG36

Medium Duty Electric Griddle

Model: GEG36

03/22/19 Rev. D

IMPORTANT!

TO EXPEDITE SHIPMENT OF PARTS, ALWAYS SPECIFY MODEL, REV,
PART NUMBER, AND SERIAL NUMBER OF UNIT.

GLOBE FOOD EQUIPMENT COMPANY

2215 East River Road
Dayton, Ohio 45439

Parts Department

Toll Free 1-800-745-6238 · Fax (937) 290-0585

E-Mail: info@globefoodequip.com

Website: www.globefoodequip.com

Not for resale

Table of Contents

Description

Page

GEG36 Electric Griddle Components

4

GEG36 Electric Griddle Schematic

6



GEG36 Electric Griddle Components

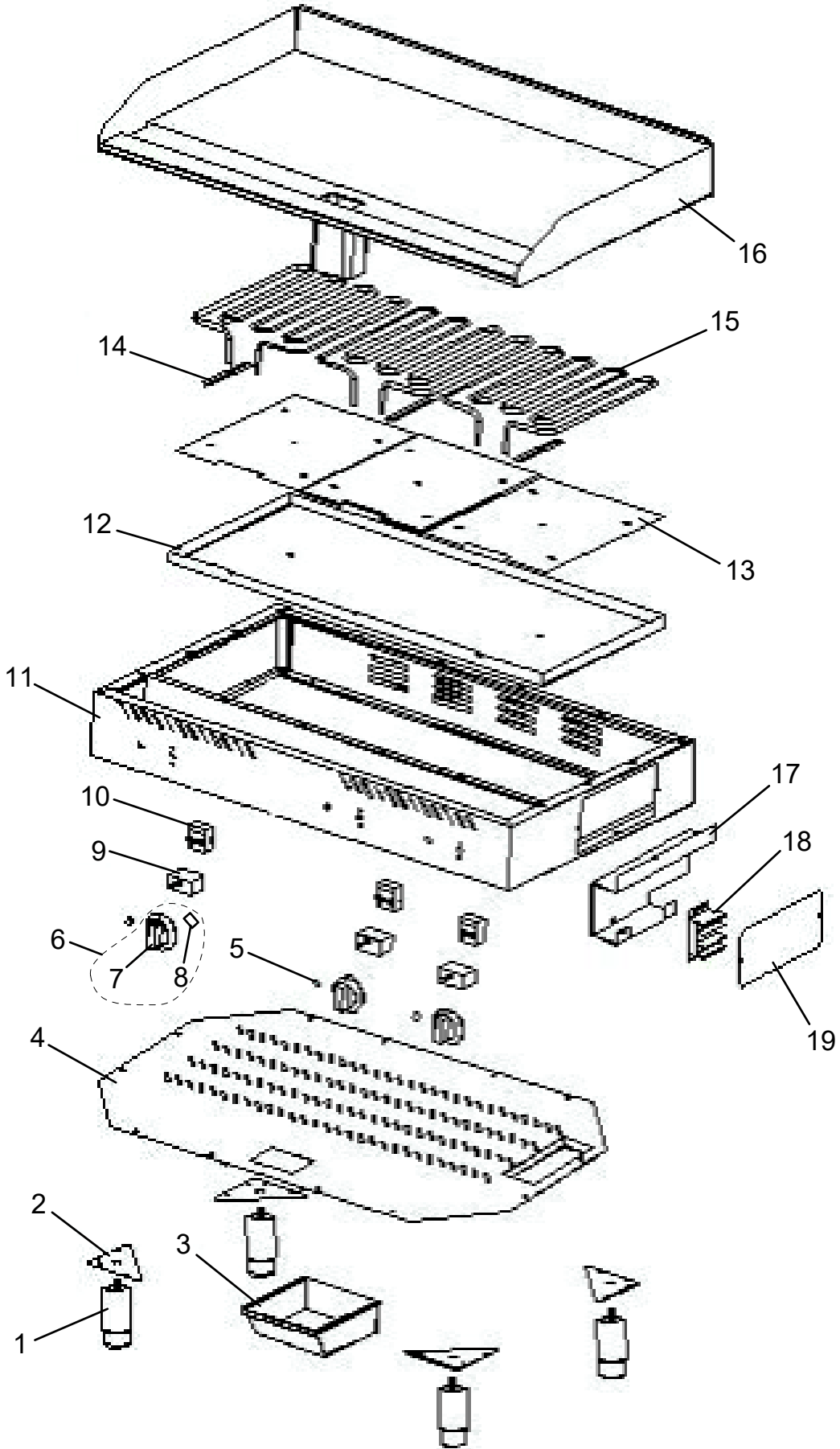



GEG36 Electric Griddle Components

| Item | Part Number | Description | Qty | Serial Number |
|------|------------------------------|-----------------------|-----|---------------|
| 1 | U01021005165 | Foot, Adjustable - SS | 4 | |
| 2 | | Plate, Foot Support | 4 | |
| 3 | U01051025574 | Drip Tray | 1 | |
| 4 | U06051470641 | Plate, Base | 1 | |
| 5 | U03091240006 | Indicator Light | 2 | |
| 6 | U01033 | Knob Assembly | 2 | |
| 7 | | Dial | 1 | |
| 8 | | Spring Plate | 1 | |
| 9 | U03041215033 | Switch, ON/OFF | 2 | |
| 10 | U03051220048 | Thermostat | 2 | |
| 11 | | Enclosure Assembly | 1 | |
| 12 | | Plate, Insulation | 1 | |
| 13 | | Plate, Element | 2 | |
| 14 | U01051027329 | Plate, Sensor | 2 | |
| 15 | U03061225104 | Heating Element | 2 | |
| 16 | | Plate, Griddle | 1 | |
| 17 | U01051027332 | Box, Connection | 1 | |
| 18 | U03081235018 | Terminal Block | 1 | |
| 19 | U01051027359 | Cover, Connection Box | 1 | |



GEG36 Electric Griddle Schematic

- NOTE:**
1. USE ONLY COPPER WIRE FOR SUPPLY CONNECTIONS. WIRE TO BE SUITABLE FOR AT LEAST 90°C (194°F). USE WIRE GAUGE SHOWN OR LARGER.
 2. ALL INTERNAL WIRING IS #14 GAUGE.

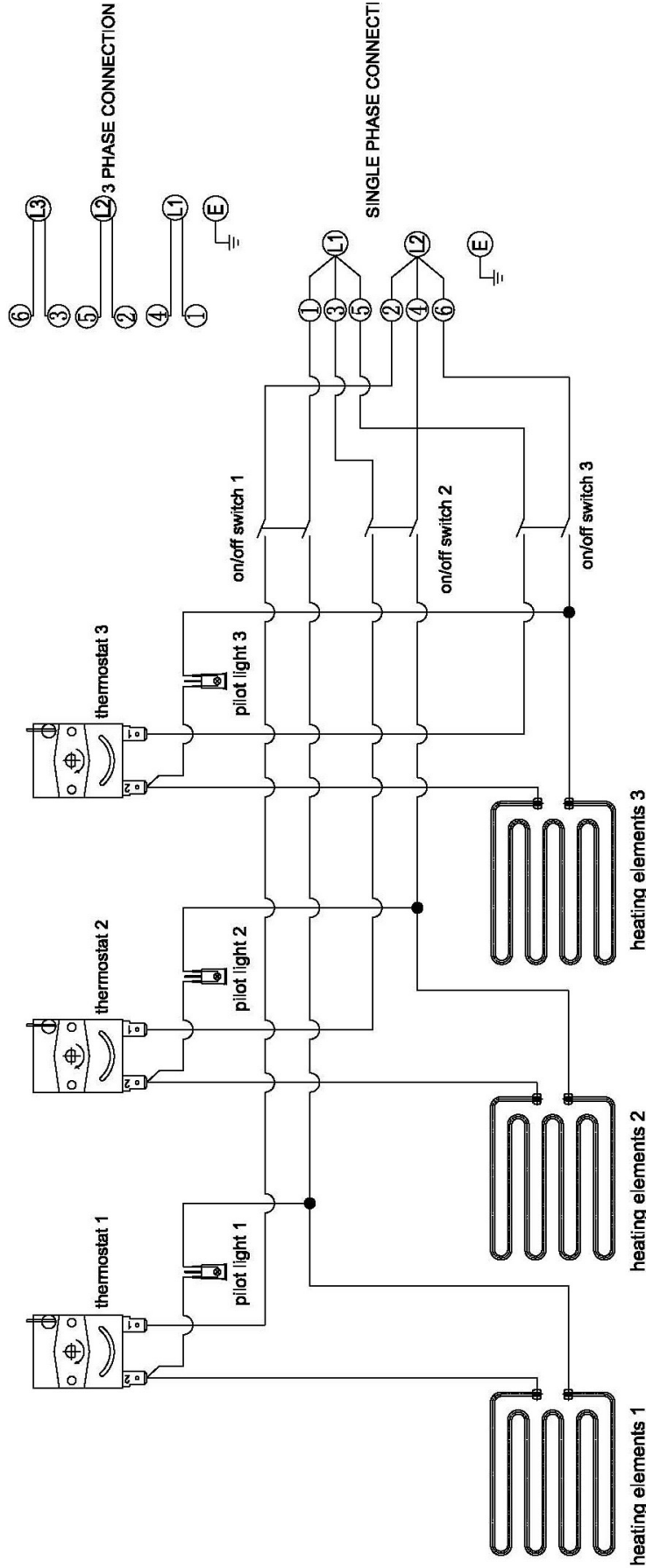

| NOMINAL AMPS PER LINE | | | |
|-----------------------|----------------|-------------|---------|
| 208V ~ 3 PHASE | 240V ~ 3 PHASE | | |
| 6,300 WATTS | | 8,400 WATTS | |
| L1 | L2 | L1 | L3 |
| 17.49 | 17.49 | 20.21 | 20.21 |
| AWG #10 | AWG #10 | AWG #10 | AWG #10 |
| | | AWG #8 | AWG #6 |
| | | 30.29 | 35 |
| | | 1 PH | 1 PH |
| | | 208V | 240V |